**Intravascular catheters — Sterile and
single-use catheters —**

Part 5:
Over-needle peripheral catheters

*Cathéters intravasculaires — Cathéters stériles et non réutilisables —
Partie 5: Cathéters périphériques à aiguille interne*





COPYRIGHT PROTECTED DOCUMENT

© ISO 2013

All rights reserved. Unless otherwise specified, no part of this publication may be reproduced or utilized otherwise in any form or by any means, electronic or mechanical, including photocopying, or posting on the internet or an intranet, without prior written permission. Permission can be requested from either ISO at the address below or ISO's member body in the country of the requester.

ISO copyright office
Case postale 56 • CH-1211 Geneva 20
Tel. + 41 22 749 01 11
Fax + 41 22 749 09 47
E-mail copyright@iso.org
Web www.iso.org

Published in Switzerland

Contents

	Page
Foreword	iv
1 Scope	1
2 Normative references	1
3 Terms and definitions	1
4 Requirements	2
4.1 General	2
4.2 Multilumen catheters	2
4.3 Physical requirements	3
4.4 Information to be supplied by the manufacturer	4
Annex A (normative) Determination of strength of union of needle hub and needle tube	5
Annex B (informative) Colours for opaque catheter hubs	6
Annex C (informative) Needle point geometries	7
Annex D (normative) Determination of liquid leakage from vent fitting	8
Bibliography	10

Foreword

ISO (the International Organization for Standardization) is a worldwide federation of national standards bodies (ISO member bodies). The work of preparing International Standards is normally carried out through ISO technical committees. Each member body interested in a subject for which a technical committee has been established has the right to be represented on that committee. International organizations, governmental and non-governmental, in liaison with ISO, also take part in the work. ISO collaborates closely with the International Electrotechnical Commission (IEC) on all matters of electrotechnical standardization.

International Standards are drafted in accordance with the rules given in the ISO/IEC Directives, Part 2.

The main task of technical committees is to prepare International Standards. Draft International Standards adopted by the technical committees are circulated to the member bodies for voting. Publication as an International Standard requires approval by at least 75 % of the member bodies casting a vote.

Attention is drawn to the possibility that some of the elements of this document may be the subject of patent rights. ISO shall not be held responsible for identifying any or all such patent rights.

ISO 10555-5 was prepared by Technical Committee ISO/TC 84, *Devices for administration of medicinal products and intravascular catheters*.

This second edition cancels and replaces the first edition (ISO 10555-5:1996), which has been technically revised. It also incorporates the Amendment ISO 10555-5:1996/Amd 1:1999 and the Technical Corrigendum ISO 10555-5:1996/Cor 1:2002.

ISO 10555 consists of the following parts, under the general title *Intravascular catheters — Sterile and single-use catheters*:

- *Part 1: General requirements*
- *Part 3: Central venous catheters*
- *Part 4: Balloon dilatation catheters*
- *Part 5: Over-needle peripheral catheters*

The following part is under preparation:

- *Part 6: Subcutaneous implanted ports*

The following part has been withdrawn and the content has been included in ISO 10555-1:

- *Part 2: Angiographic catheters*

Attention is drawn to ISO 11070, which specifies requirements for accessory devices for use with intravascular catheters, and to ISO 14972, which specifies requirements for sterile obturators for use with over-needle peripheral catheters.

Intravascular catheters — Sterile and single-use catheters —

Part 5: Over-needle peripheral catheters

1 Scope

This part of ISO 10555 specifies requirements for over-needle peripheral intravascular catheters, intended for accessing the peripheral vascular system, supplied in the sterile condition and intended for single use.

2 Normative references

The following documents, in whole or in part, are normatively referenced in this document and are indispensable for its application. For dated references, only the edition cited applies. For undated references, the latest edition of the referenced document (including any amendments) applies.

ISO 594-1, *Conical fittings with a 6 % (Luer) taper for syringes, needles and certain other medical equipment — Part 1: General requirements*¹⁾

ISO 9626, *Stainless steel needle tubing for the manufacture of medical devices*

ISO 10555-1, *Intravascular catheters — Sterile and single-use catheters — Part 1: General requirements*

3 Terms and definitions

For the purposes of this document, the terms and definitions given in ISO 10555-1 and the following apply.

3.1

over-needle peripheral intravascular catheter

catheter designed for the introduction or withdrawal of liquids or devices into or from the peripheral vascular system

3.2

needle

assembly comprising at least a needle tube attached to, and communicating with, a needle hub

See [Figure 1](#).

3.3

needle tube

rigid tube with one end sharpened to facilitate entry into body tissue

3.4

needle hub

fitting attached to the needle tube, providing communication with its bore

3.5

vent fitting

fixed or removable fitting permitting venting of air while restricting or preferably preventing the escape of blood

1) Upon its publication, ISO 80369-7 will replace ISO 594-1 and ISO 594-2.

3.6 catheter unit

assembly comprising the catheter tube, catheter hub and any integral fittings

See [Figure 1](#).

3.7 flashback

blood flow into the needle hub

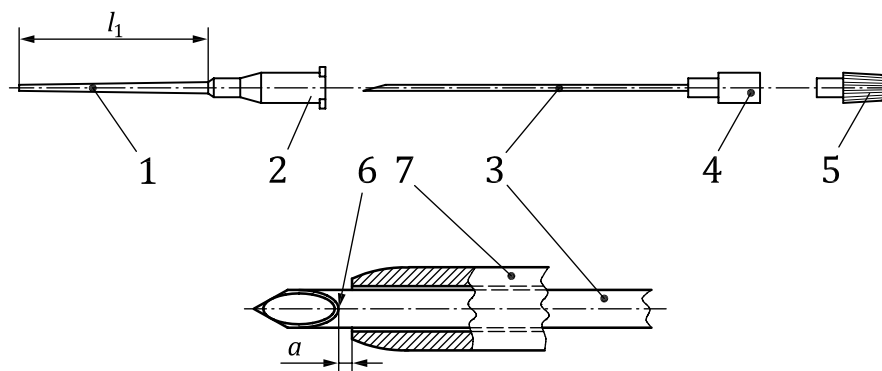

Key

- a $0 < a < 1$ mm (see [4.3.2](#))
- l_1 effective length
- 1 catheter tube
- 2 catheter hub
- 3 needle tube
- 4 needle hub
- 5 vent fitting
- 6 heel of bevel
- 7 catheter unit

NOTE Other design features may include wings, injection ports integral with the catheter hub, other means of connecting to the fluid path, protection against accidental needle stick injury, etc. The catheter tube may have a single lumen or multiple lumens.

Figure 1 — Typical over-needle peripheral intravascular catheter

4 Requirements

4.1 General

Unless otherwise specified in this part of ISO 10555, over-needle peripheral catheters shall comply with ISO 10555-1.

4.2 Multilumen catheters

For multilumen catheters, identification of each lumen shall be apparent to the user.

4.3 Physical requirements

4.3.1 Colour code

The catheter unit shall be colour coded in accordance with [Table 1](#) to indicate the nominal outside diameter of the catheter tube.

4.3.2 Catheter unit

The distal end shall be tapered for ease of insertion and shall fit closely to the needle. When the needle is fully inserted into the catheter unit, the catheter tube shall neither extend beyond the heel of the needle bevel nor be more than 1 mm from it (see dimension *a* in [Figure 1](#)).

4.3.3 Needle

4.3.3.1 Material

If a steel tube is used, it shall comply with ISO 9626.

Table 1 — Colour coding and corresponding sizes of catheter

Nominal outside diameter of catheter tube mm	Range of actual outside diameter mm	Colour ^{a,b}	Gauge ^c
0,6	0,550 to 0,649	Violet	26
0,7	0,650 to 0,749	Yellow	24
0,8; 0,9	0,750 to 0,949	Deep blue	22
1,0; 1,1	0,950 to 1,149	Pink	20
1,2; 1,3	1,150 to 1,349	Deep green	18
1,4; 1,5	1,350 to 1,549	White	17
1,6; 1,7; 1,8	1,550 to 1,849	Medium grey	16
1,9; 2,0; 2,1; 2,2	1,850 to 2,249	Orange	14
2,3; 2,4; 2,5	2,250 to 2,549	Red	13
2,6; 2,7; 2,8	2,550 to 2,849	Pale blue	12
3,3; 3,4	3,250 to 3,549	Light brown	10

a The colour may be opaque or translucent. Suggested colour references for opaque materials are given in [Annex B](#).
b The colour coding is usually applied to the catheter hub or to an integral fitting.
c The use of gauge number is optional.

4.3.3.2 Needle point

When examined by normal or corrected-to-normal vision with $\times 2,5$ magnification, the needle point shall appear sharp and free from feather edges, burrs and hooks.

NOTE The point should be designed to be non-coring. [Annex C](#) shows examples of typical needle point geometries.

4.3.3.3 Needle hub

The needle hub or another feature shall permit detection of flashback and shall be designed to communicate with the bore of the introducer needle tube. If the introducer needle is provided with a removable vent fitting, the needle hub shall terminate in a female fitting with a 6 % (Luer) taper complying with ISO 594-1.

4.3.3.4 Strength of union between needle hub and needle tube

When tested in accordance with [Annex A](#), the needle tube shall not be loosened in the needle hub.

4.3.4 Vent fitting

A vent fitting shall be provided. When tested in accordance with [Annex D](#), fluid shall not leak out of the vent fitting within 15 s.

4.4 Information to be supplied by the manufacturer

Information supplied by the manufacturer shall comply with ISO 10555-1 and shall also include the following:

- a) the flowrate for each lumen;
- b) a warning against attempting to re-insert a partially or completely withdrawn needle;
- c) on each primary package, the colour code, unless the colour on the product is visible through the unit package, and the outside diameter, as defined in [Table 1](#).

NOTE Units of measurement systems other than those specified in this part of ISO 10555 can additionally be given.

Annex A (normative)

Determination of strength of union of needle hub and needle tube

A.1 Principle

A force is applied (successively tensile and compressive) to the needle tube and needle hub and the tube-hub union is then examined for loosening.

A.2 Apparatus

Tensile testing apparatus, capable of exerting forces of up to 20 N with an accuracy of $\pm 1\%$.

A.3 Test procedure

A.3.1 Condition the needle in an atmosphere of 40 % to 60 % relative humidity and a temperature of (22 ± 2) °C for 2 h immediately before the test.

A.3.2 Clamp the needle tube and the needle hub in the jaws of the tensile testing apparatus and apply successively, once each, at a rate of 100 mm/min, a tensile and a compressive force of

- 10 N when testing needles of nominal outside diameter less than 0,6 mm;
- 20 N when testing needles of nominal outside diameter 0,6 mm or greater.

A.3.3 Examine the union of needle tube and needle hub and record whether the needle tube has been loosened.

A.4 Test report

The test report shall include the following information:

- a) identity of the needle;
- b) outside diameter of the needle, expressed in millimetres;
- c) load applied (i.e. 10 N or 20 N);
- d) whether or not the needle tube was loosened in the hub.

Annex B (informative)

Colours for opaque catheter hubs

Suggested colour references are given for information in [Table B.1](#).

Table B.1 — Suggested colours for opaque catheter hubs

Nominal outside diameter of catheter tube mm	Colour code	Munsell Atlas ^[7]	US Federal Standard 595a ^[8]	DIN 6164-1 ^[5]	NF X 08-002 ^[6]
0,6	Violet	5 P 6.5/6	—	—	A 2790
0,7	Yellow	3.75 Y 8/14	23 655	1.9; 6.8; 0.7	A 330
0,8; 0,9	Deep blue	2.5 PB 3/8	15 090	16.6; 6.5; 4.2	A 540
1,0; 1,1	Pink	2.5 R 7/6	11 630	8.5; 1.4; 1.5	A 870
1,2; 1,3	Deep green	2.5 G 4/8	14 090	22.6; 6.9; 5.0	A 455
1,4; 1,5	White	N 9.5	27 875	1.0; 0.4; 0.3	A 665
1,6; 1,7; 1,8	Medium grey	N 7	26 231	24.4; 0.2; 3.9	A 630
1,9; 2,0; 2,1; 2,2	Orange	3.75 YT 6/12	12 473	4.5; 6.6; 1.7	A 130
2,3; 2,4; 2,5	Red	7.5 R 4/14	—	7.4; 7.9; 2.7	A 801
2,6; 2,7; 2,8	Pale blue	2.5 PB 7/8	35 190	17.5; 4.4; 2.0	A 590
3,3; 3,4	Light brown	7.5 YR 4.5/6	—	—	A 2030

Annex C (informative)

Needle point geometries

Typical needle point geometries are shown for information in [Figure C.1](#).

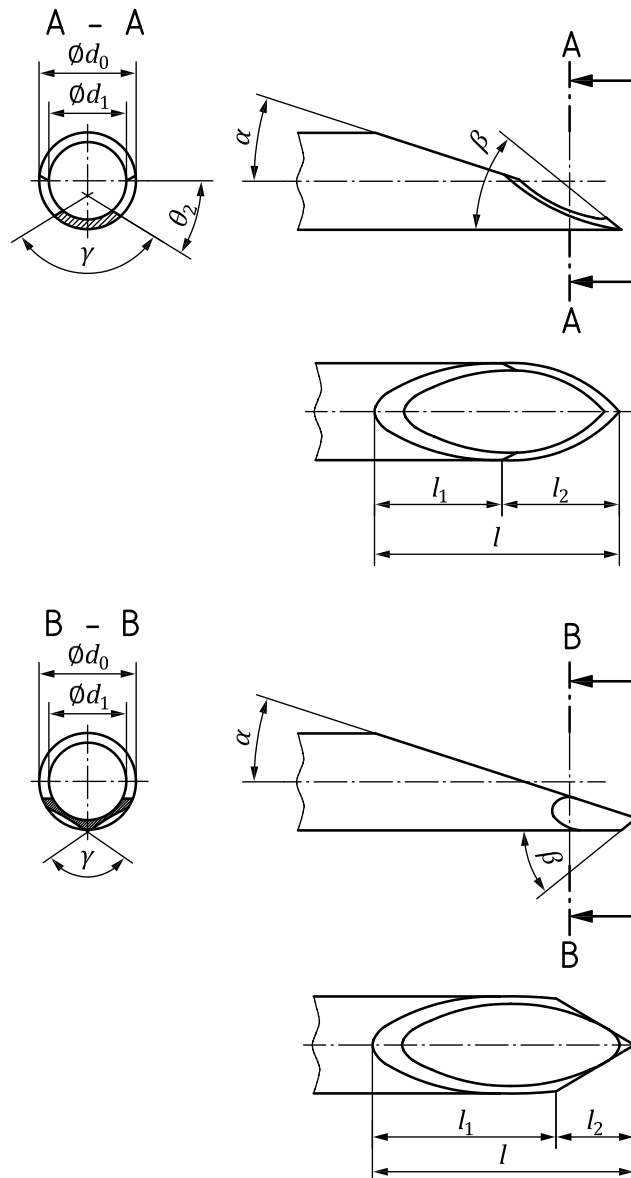

Key

d_0	outside diameter of the needle tube	α	primary bevel angle
d_1	inside diameter of the needle tube	β	tip angle
l	point length	θ_2	secondary bevel rotation angle
l_1	primary bevel nominal length	γ	combined secondary bevel angle
l_2	secondary bevel nominal length		

Figure C.1 — Examples of typical needle point geometries

Annex D (normative)

Determination of liquid leakage from vent fitting

D.1 Principle

The catheter is connected to a source of simulated blood under hydrostatic pressure. The fluid is allowed to flow into the needle and the time taken for fluid to leak through the vent fitting is measured.

D.2 Test fluid

D.2.1 Prepare a solution of sodium chloride [0,9 % (m/V)] by dissolving 9 g of reagent grade sodium chloride in distilled or deionized water to make 1 l of solution.

D.2.2 Prepare the test fluid by mixing 550 ml of sodium chloride solution (D.2.1) and 450 ml of glycerol of USP grade or better.

NOTE To improve the visibility of the solution, a colorant such as red or blue food dye may be incorporated.

D.3 Apparatus

D.3.1 Constant-level tank, to provide a hydrostatic head of (400 ± 20) mm, fitted with a delivery tube of inside diameter not less than 3 mm having a clamp or valve and at its end a puncturable membrane (e.g. a latex cap). See [Figure D.1](#) for an example of such apparatus.

D.3.2 Stopwatch, or similar device.

D.4 Procedure

D.4.1 Supply the constant-level tank (D.3.1) with test fluid (D.2) at (23 ± 2) °C.

D.4.2 Remove all air from the delivery tube and close the clamp or valve.

D.4.3 Insert the tip of the needle tube through the membrane, ensuring that the needle tube is kept horizontal at ± 5 degrees.

D.4.4 Open the clamp or valve so as to allow fluid to enter the needle tube. Measure the time taken for fluid to form the first falling drop at the back of the vent fitting.

D.5 Test report

The test report shall contain at least the following information:

- a) the identity of the catheter being tested;
- b) the time, in seconds, for the first drop of test fluid to fall.

Dimensions in millimetres

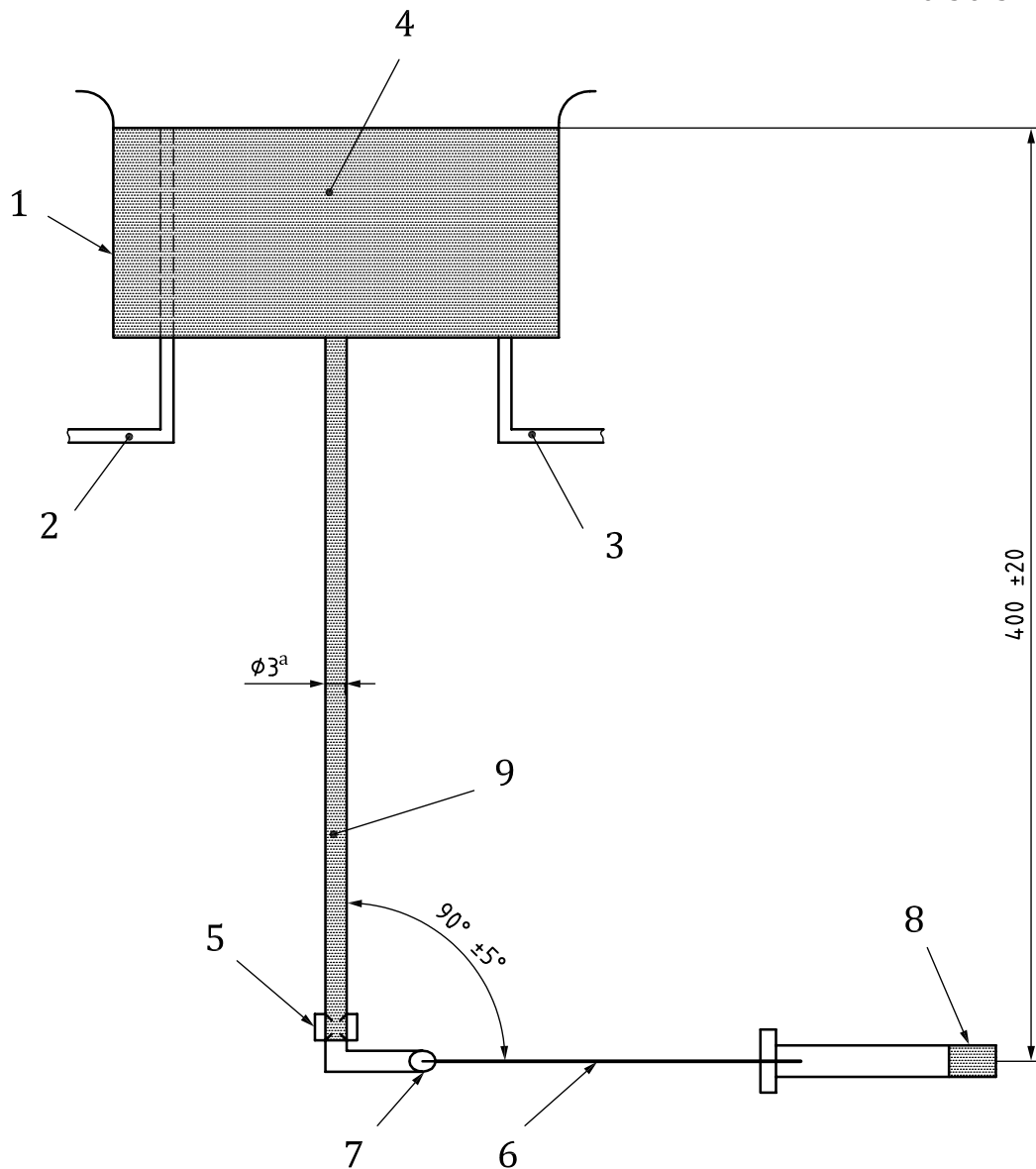
**Key**

- 1 constant-level tank
- 2 overflow
- 3 inlet
- 4 test fluid
- 5 clamp or valve
- 6 needle tube
- 7 membrane
- 8 vent fitting
- 9 delivery tube
- a Internal diameter.

Figure D.1 — Example of apparatus for determination of liquid leakage from vent fitting

Bibliography

- [1] ISO 11070, *Sterile, single-use intravascular catheter introducers*
- [2] ISO 14972, *Sterile obturators for single use with over-needle peripheral intravascular catheters*
- [3] ISO 7864, *Sterile hypodermic needles for single use*
- [4] IEC 80369-6, *Small bore connectors for liquids and gases in healthcare applications — Part 6: Connectors for neuraxial applications²⁾*
- [5] DIN 6164-1, *DIN Farbenkarte; System der DIN Farbenkarte für den 2°-Normalbeobachter. Available from Beuth Verlag GmbH, Burggrafenstrasse 6, D-10787 Berlin, Germany*
- [6] NF X 08-002, *Collection réduite des couleurs — Désignation et catalogue des couleurs CCR — Étalons secondaires*. (Limited collection of colours. Designation and catalogue of CCR colours. Secondary standards.) Available from AFNOR, Tour Europe, Cedex 7, F-92080 Paris La Défense, France
- [7] *Munsell Book of Color*. Available from Munsell Color, 2441 N. Calvert Street, Baltimore, MD 21218 USA
- [8] US Federal Standard 595a: *Colors*, Volume 1. Available from Superintendent of Documents, US Government Printing Office, Washington DC, 20402 USA

2) Under preparation.