

INTERNATIONAL STANDARD

ISO
10544

First edition
1992-12-15

Cold-reduced steel wire for the reinforcement of concrete and the manufacture of welded fabric

*Fils en acier à béton transformés à froid pour armatures passives et la
fabrication des treillis soudés*



Reference number
ISO 10544:1992(E)

Foreword

ISO (the International Organization for Standardization) is a worldwide federation of national standards bodies (ISO member bodies). The work of preparing International Standards is normally carried out through ISO technical committees. Each member body interested in a subject for which a technical committee has been established has the right to be represented on that committee. International organizations, governmental and non-governmental, in liaison with ISO, also take part in the work. ISO collaborates closely with the International Electrotechnical Commission (IEC) on all matters of electrotechnical standardization.

Draft International Standards adopted by the technical committees are circulated to the member bodies for voting. Publication as an International Standard requires approval by at least 75 % of the member bodies casting a vote.

International Standard ISO 10544 was prepared by Technical Committee ISO/TC 17, *Steel*, Sub-Committee SC 16, *Steels for the reinforcement and prestressing of concrete*.

Annexes A and B of this International Standard are for information only.

© ISO 1992

All rights reserved. No part of this publication may be reproduced or utilized in any form or by any means, electronic or mechanical, including photocopying and microfilm, without permission in writing from the publisher.

International Organization for Standardization
Case Postale 56 • CH-1211 Genève 20 • Switzerland

Printed in Switzerland

Cold-reduced steel wire for the reinforcement of concrete and the manufacture of welded fabric

1 Scope

This International Standard specifies technical requirements for cold-reduced steel wire designed for the reinforcement of concrete or for use in welded fabric.

One steel grade, 500 N/mm², is defined.

This International Standard applies to wire made from rod by working through dies or rollers. The production process is at the discretion of the manufacturer.

For wire supplied in coil form, the requirements of this International Standard apply to the straightened product.

Wires produced from finished products, such as plates and railway rails, are excluded.

2 Normative references

The following standards contain provisions which, through reference in this text, constitute provisions of this International Standard. At the time of publication, the editions indicated were valid. All standards are subject to revision, and parties to agreements based on this International Standard are encouraged to investigate the possibility of applying the most recent editions of the standards indicated below. Members of IEC and ISO maintain registers of currently valid International Standards.

ISO 404:1992, *Steel and steel products — General technical delivery requirements*.

ISO 6892:1984, *Metallic materials — Tensile testing*.

ISO/TR 9769:1991, *Steel and iron — Review of available methods of analysis*.

ISO 10065:1990, *Steel bars for reinforcement of concrete — Bend and rebend tests*.

ISO 10144:1991, *Certification scheme for steel bars and wires for the reinforcement of concrete structures*.

3 Definitions

For the purposes of this International Standard, the following definitions apply.

3.1 cas analysis: Chemical analysis of a sample of the molten steel during casting.

3.2 certification scheme: Certification system as related to specified products, processes or services to which the same particular standards and rules, and the same procedure, apply. [ISO/IEC Guide 2]

3.3 characteristic value: Value having a prescribed probability of not being attained in a hypothetical unlimited test series. [ISO 8930]

NOTE 1 Equivalent to *fractile*, which is defined in ISO 3534.

3.4 core: The part of cross-section of the wire that contains neither ribs nor indentations.

3.5 inclination of indentation, β : The angle between the indentation and the longitudinal axis of the wire. (See figure 2.)

3.6 indentation spacing, c : The distance between the centres of two consecutive indentations measured parallel to the axis of the wire. (See figure 2.)

3.7 indented wire: Wire with a regular pattern of surface indentations to enhance its bond properties.

3.8 inspection: Activities such as measuring, examining, testing, gauging one or more characteristics of a product or service and comparing these with specified requirements to determine conformity. [ISO 8402]

3.9 nominal cross-sectional area: The cross-sectional area equivalent to the area of a circular plain wire of the nominal diameter.

3.10 plain wire: Smooth surfaced wire without bond enhancing properties.

3.11 product analysis: Chemical analysis of a sample from a wire.

3.12 rib height, a : The distance from the highest point of the rib to the surface of the core, to be measured normal to the axis of the wire. (See figure 1.)

3.13 rib inclination, β : The angle between the rib and the longitudinal axis of the wire. (See figure 1.)

3.14 rib spacing, c : The distance between the centres of two consecutive transverse ribs measured parallel to the axis of the wire. (See figure 1.)

3.15 ribbed wire: Wire with a regular pattern of surface protrusions designed to enhance its bond properties.

3.16 test unit: The number of pieces or the tonnage of products to be accepted or rejected together, on the basis of the tests to be carried out on sample products in accordance with the requirements of the product standard or order. [ISO 404]

3.17 specific projected indentation area, f_p : The area of the projections of all indentations on a plane

perpendicular to the longitudinal axis of the wire, divided by the wire length and the nominal circumference. (See 5.2.)

3.18 specific projected rib area, f_r : The area of the projections of all ribs on a plane perpendicular to the longitudinal axis of the wire, divided by the wire length and the nominal circumference. (See 5.1.)

3.19 transversal indentationless perimeter, $\sum e_i$: The sum of the distances along the surface of the core between the transverse indentations of adjacent rows measured as the projection on a plan perpendicular to the wire axis. (See figure 2).

3.20 transversal ribless perimeter, $\sum f_i$: The sum of the distances along the surface of the core between the transverse ribs of adjacent rows measured as the projection on a plane perpendicular to the wire axis. (See figure 1.)

4 Dimensions, masses and tolerances

The nominal diameter of the wire shall be in the range from 4 mm to 16 mm. Recommended nominal diameters, d , are given in table 1.

For nominal diameters not listed in table 1, the mass divided by length shall be $7\,850 \text{ kg/m}^3 \times \text{nominal cross-sectional area}$.

The permissible deviation for intermediate sizes shall not exceed that of the next higher size in table 1. For nominal diameters from 12 mm and 16 mm, the permissible deviation shall be $\pm 5\%$.

Table 1 — Recommended diameters and required masses

Nominal wire diameter mm	Nominal cross-sectional area mm ²	Mass divided by length	
		Requirement kg/m	Permissible deviation ¹⁾ %
5	19,6	0,154	± 9
6	28,3	0,222	± 8
7	38,5	0,302	± 8
8	50,3	0,395	± 8
9	63,6	0,499	± 5
10	78,5	0,617	± 5
12	113,1	0,888	± 5

1) Refers to a single wire.

5 Geometry of ribbed and indented wires

5.1 Ribbed wire

Ribbed wire shall have two or more rows of transverse ribs equally distributed around the perimeter with a substantially uniform spacing not greater than $0,8 \times d$, where d is the nominal diameter. Figure 1 shows an example with three rows.

The minimum value for the specific projected rib area, f_r , shall be

0,036 for $4 \text{ mm} \leq d < 5 \text{ mm}$;

0,039 for $5 \text{ mm} \leq d \leq 6 \text{ mm}$;

0,045 for $6 \text{ mm} < d \leq 8 \text{ mm}$;

0,052 for $8 \text{ mm} < d \leq 10 \text{ mm}$;

0,056 for $10 \text{ mm} < d \leq 16 \text{ mm}$.

f_r is calculated using the formula

$$f_r = \frac{k \times F_R \times \sin \beta}{\pi \times d \times c}$$

where

k is the number of rib rows;

F_R is the area of the projection of one rib on a plane parallel to that rib;

β is the rib inclination relative to the axis of the wire;

d is the nominal diameter of the wire;

c is the rib spacing.

In the area of marking, deviations from the requirements of this subclause may occur (see 10.1).

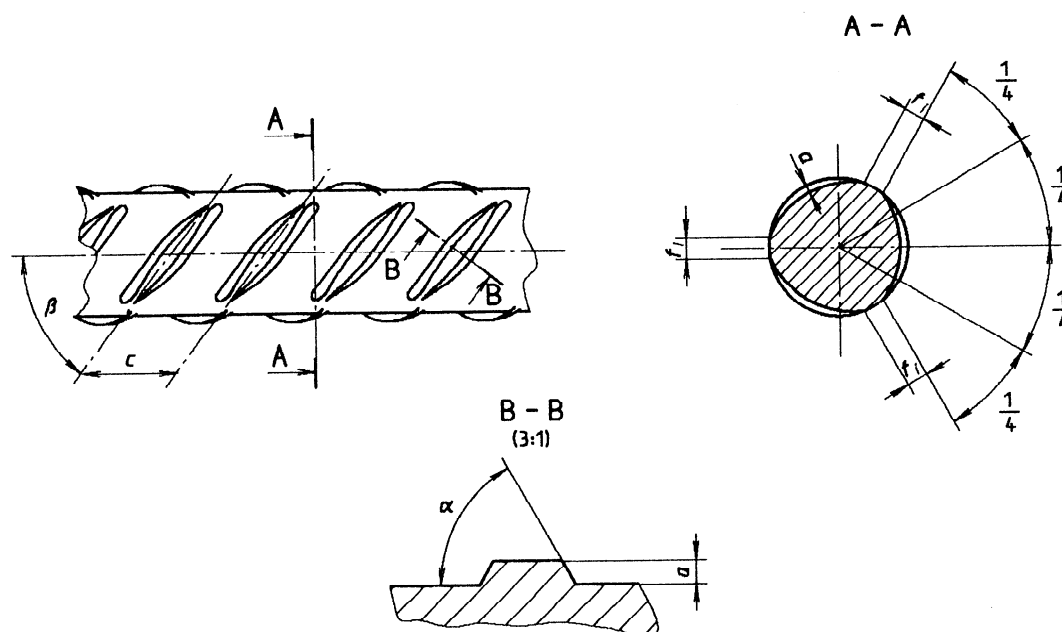

- β Rib inclination
- c Rib spacing
- f_i 1/3 of the transversal ribless perimeter
- a Rib height
- α Rib flank inclination

Figure 1 — Example of ribbed wire with three rows

5.2 Indented wire

Indented wire shall have two or more rows of indentations. The indentations shall be distributed uniformly over the circumference and length of the wire. Figure 2 shows an example with three rows.

The minimum value for the specific projected indentation area, f_p , shall be

- 0,007 for $4 \text{ mm} \leq d < 5 \text{ mm}$;
- 0,008 for $5 \text{ mm} \leq d \leq 6 \text{ mm}$;
- 0,010 for $6 \text{ mm} < d \leq 8 \text{ mm}$;
- 0,013 for $8 \text{ mm} < d \leq 10 \text{ mm}$;
- 0,014 for $10 \text{ mm} < d \leq 16 \text{ mm}$.

f_p is calculated using the formula

$$f_p = \frac{k \times F_p \times \sin \beta}{\pi \times d \times c}$$

where

- k is the number of indentation rows;
- F_p is the area of the projection of one indentation on a plane parallel to that indentation;
- β is the inclination of the indentation relative to the axis of the wire;
- d is the nominal diameter of the wire;
- c is the indentation spacing (see figure 2).

In the area of marking, deviations from the requirements of the subclause may occur (see 10.1).

6 Chemical composition

The steel shall not contain quantities of the given elements higher than those specified in table 2.

The carbon equivalent, C_{eq} , is calculated according to the formula

$$C_{eq} = C + \frac{Mn}{6} + \frac{(Cr + V + Mo)}{5} + \frac{(Cu + Ni)}{15}$$

where C, Mn, Cr, V, Mo, Cu and Ni are percentages by mass of the respective elements of the steel.

In the case of dispute about analytical methods, the chemical composition shall be determined by an appropriate referee method specified in one of the International Standards listed in ISO/TR 9769.

7 Mechanical properties

7.1 Tensile properties

Required tensile properties are given in table 3.

At least 95 % of the population under consideration shall have tensile properties equal to or above the characteristic value specified.

No single test result shall be less than 95 % of the characteristic value given in table 3.

The ratio of tensile strength to proof stress, $R_m/R_{p0,2}$, for each test piece shall be at least 1,03.

By agreement between manufacturer and purchaser, the values in table 5 may be used as guaranteed minimum values.

7.2 Bending properties

After testing, none of the test pieces shall show fractures or cracks visible to the naked eye.

7.3 Rebending properties

By agreement between manufacturer and purchaser, the rebend test may replace the bend test.

The rebend test is used to verify the ageing properties of bent wires.

After testing, none of the test pieces shall have fractures or cracks visible to the naked eye.

8 Testing of mechanical properties

The testing shall be done on wires in the straightened condition. The test piece may be heated to 100 °C and then cooled freely in air to the test temperature.

8.1 Tensile test

The tensile properties shall be determined according to ISO 6892. The test piece shall have an original gauge length of 5 times the nominal diameter. The free distance between the grips shall be not less than 180 mm.

For calculation of proof stress and tensile strength, the nominal cross-sectional area of the wire shall be used.

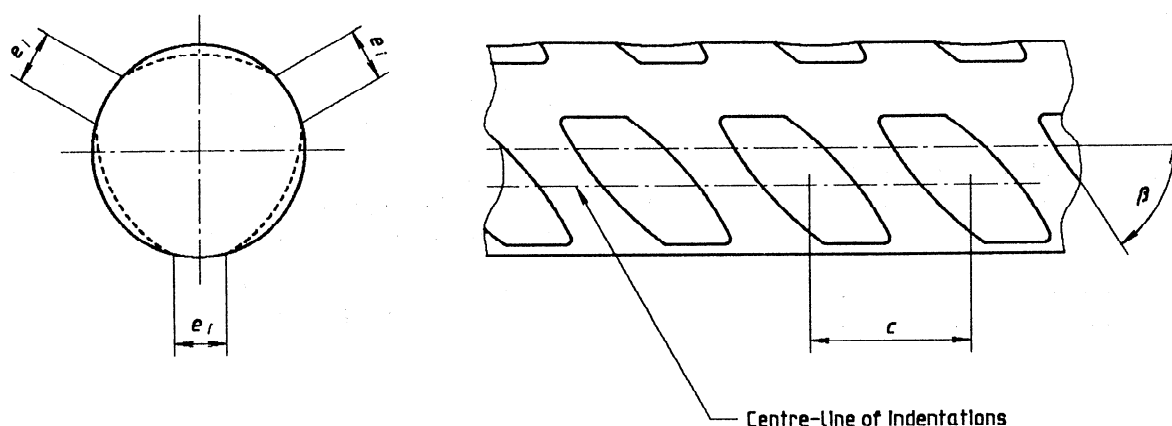

c Indentation spacing
 e_i 1/3 of the transversal indentationless perimeter

Figure 2 — Example of indented wire with three rows

Table 2 — Chemical composition — Maximum values in percentage by mass

C	Si	Mn	P	S	N ¹⁾	C _{eq}
0,22 (0,24) ²⁾	0,60 (0,65)	1,60 (1,70)	0,050 (0,055)	0,050 (0,055)	0,012 (0,013)	0,50 (0,52)

- 1) A higher nitrogen content may be used if sufficient quantities of nitrogen-binding elements are present.
 2) The values in brackets apply for the product analysis.

Table 3 — Characteristic values for proof stress at 0,2 % non-proportional elongation, tensile strength and elongation after fracture on a gauge length of 5 times the nominal diameter

Proof stress $R_{p0,2}$ N/mm ²	Tensile strength R_m N/mm ²	Elongation ¹⁾ $A_{5,65}$ %
500	550	12

1) By agreement between purchaser and supplier, a total elongation at maximum force (A_{gt}) of 2,0 % shall be used instead of $A_{5,65}$.

8.2 Bend test

The bend test shall be carried out according to ISO 10065.

The test piece shall be bent to an angle between 160° and 180° over a mandrel of the diameter specified in table 4.

The mandrel diameter for intermediate sizes shall be that of the next lower size in table 4.

8.3 Rebind test

The rebind test shall be carried out according to ISO 10065. The test piece shall be bent over a mandrel of the diameter specified in table 5.

The angle of bend, before heating (ageing) shall be 90°, and the angle of rebind shall be 20°. Both angles shall be measured before unloading.

The mandrel diameter for intermediate sizes shall be that of the next lower size in table 5.

Table 4 — Mandrel diameter to be used for the bend test

Dimensions in millimetres

Nominal diameter of wire, <i>d</i>	(4) ¹⁾	5	6	7	8	9	10	12	(14)	(16)
Mandrel diameter, <i>D</i>	(12)	16	20	20	25	32	32	40	(50)	(63)
1) Nominal diameters in brackets are not recommended in clause 4.										

Table 5 — Mandrel diameter to be used for the rebind test

Dimensions in millimetres

Nominal diameter of wire, <i>d</i>	(4) ¹⁾	5	6	7	8	9	10	12	(14)	(16)
Mandrel diameter, <i>D</i>	(20)	25	32	32	40	50	50	63	(80)	(100)
1) Nominal diameters in brackets are not recommended in clause 4.										

9 Designation

Wire according to this International Standard shall be designated in the following order:

- reinforcing steel;
- the number of this International Standard;
- nominal diameter, in millimetres;
- surface configuration (plain, indented or ribbed).

EXAMPLE

Reinforcing steel ISO 10544 — 8 mm indented

10 Marking

10.1 Marking on the wire

It is recommended that indented and ribbed wire should have an identification of the manufacturer introduced during rolling. Examples are shown in annex A.

10.2 Marking of bundles or coils

Each bundle or coil of at least 500 kg shall have a label stating the manufacturer, number of this International Standard, nominal diameter, cast number or reference related to test record, and country of origin.

11 Certification and inspection

Certification and inspection of reinforcement shall be performed

- in accordance with a certification scheme monitored by an external body (see ISO 10144);
- or
- according to testing of a specific delivery.

11.1 Certification scheme

In the case of a certification scheme, certification and inspection shall be performed in accordance with ISO 10144.

11.2 Testing of a specific delivery

Provisions regarding the nature, extent and evaluation of acceptance tests on deliveries of cold-reduced wire not subject to a certification scheme are given in 11.3 and 11.4.

Testing of a specific delivery shall be performed according to 11.3.

By agreement between manufacturer and purchaser, 11.4 may be used.

11.3 Verification of conformity

11.3.1 Organization

The tests shall be organized and carried out according to an agreement between purchaser and manufacturer, taking into consideration the national rules of the receiving country.

11.3.2 Extent of sampling and testing

For the purpose of testing, the delivery shall be subdivided into test units with a maximum mass of 50 t or a fraction thereof. Each test unit shall consist of products of the same nominal diameter from the same cast. When required by the purchaser, the chemical composition (cast analysis) shall be stated in the test report.

Test pieces shall be taken from each test unit as follows:

- a) two test pieces from different coils or straightened wires for testing the chemical composition (product analysis);
- b) fifteen test pieces (if appropriate 60 test pieces; see 11.3.3.1) from different coils or straightened wires for testing all other properties specified in this International Standard.

11.3.3 Evaluation of the results

11.3.3.1 Inspection by variables

For properties which are specified as characteristic values, the following shall be determined:

- a) all individual values, x_i , of the 15 test pieces ($n = 15$);
- b) the mean value, m_{15} (for $n = 15$);
- c) the standard deviation, s_{15} (for $n = 15$).

The test unit corresponds to the requirements if the condition stated below is fulfilled for all properties:

$$m_{15} - 2,33 \times s_{15} \geq f_k$$

where

f_k is the required characteristic value;

2,33 is the value for the acceptability index, k , for $n = 15$ for a failure rate of 5 % ($p = 0,95$) at a probability of 90 % ($1 - \alpha = 0,90$).

If the condition stated above is not fulfilled, the index

$$k' = \frac{m_{15} - f_k}{s_{15}}$$

is determined from the test results available. Where $k' \geq 2$, testing can be continued. In this case 45 further test pieces shall be taken and tested from different coils or straightened wires, so that a total of 60 test results are available ($n = 60$).

The test unit shall be considered to comply with the requirements if the condition stated below is fulfilled for all properties:

$$m_{60} - 1,93 \times s_{60} > f_k$$

where 1,93 is the value for the acceptability index, k , for $n = 60$ for a failure rate of 5 % ($p = 0,95$) at a probability of 90 % ($1 - \alpha = 0,90$).

11.3.3.2 Inspection by attributes

When testing properties specified as maximum or minimum values, all results determined on the 15 test pieces shall comply with the requirements of this International Standard. In this case the test unit shall be considered to comply with the requirements.

The tests can be continued when at most 2 results not conforming to conditions occur. In this case 45 further test pieces from different coils or straightened wires in the test unit shall be tested, so that a total of 60 test results are available. The test unit complies with the requirements if at most 2 of the 60 results do not conform to the conditions.

11.3.3.3 Chemical composition

Both test pieces shall comply with the requirements in clause 6.

11.4 Verification of guaranteed minimum values

Tests shall be carried out according to the following.

- For the purpose of testing, the delivery shall be subdivided into test units with a maximum mass of 50 t or a fraction thereof. Each test unit shall consist of products of the same nominal diameter from the same cast. When required by the purchaser, the chemical composition (cast analysis) shall be stated in the test report.
- For each mechanical property specified, one test shall be carried out for each test unit. Each individual test result shall meet the requirements specified in clause 7.
- If any test result does not meet the requirements, retests may be carried out, according to ISO 404.
- The manufacturer shall submit a test report stating that products of the delivery satisfies the mechanical properties specified in clause 7, and a confirmation that the other requirements of this International Standard are fulfilled.

12 Test report

The test report shall contain the following information:

- a) works producing the steel wire;
- b) designation of the wire according to clause 9;
- c) number on the bundle;
- d) name of the organization carrying out the test, if appropriate;
- e) date of testing;
- f) mass of the test unit;
- g) test results.

Annex A (informative)

Identification of origin on the wire

If the manufacturer is identified by a number, this number can be indicated by the ribs or the indentations as shown in figure A.1 or A.2.

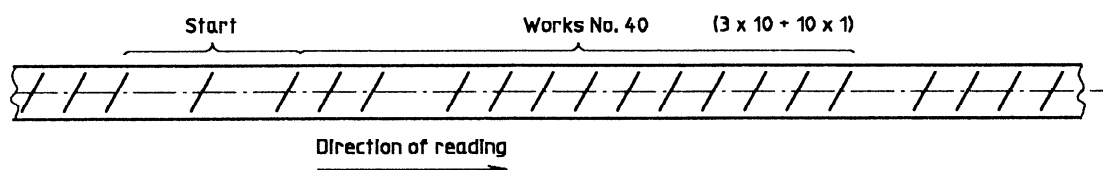

Figure A.1 — Example of identification of manufacturer on ribbed wire

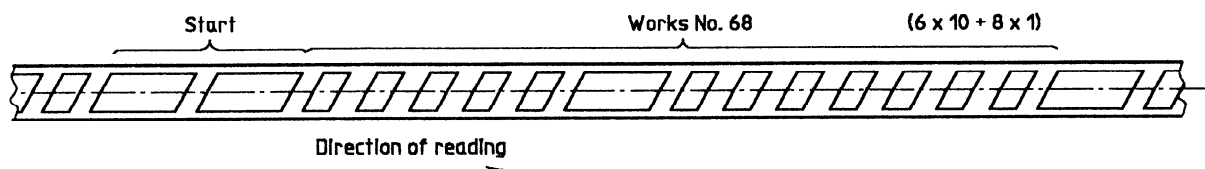

Figure A.2 — Example of identification of manufacturer on indented wire

Annex B
(informative)

Bibliography

- [1] ISO 3534:1977, *Statistics — Vocabulary and symbols*.
- [2] ISO 8402:1986, *Quality — Vocabulary*.
- [3] ISO 8930:1987, *General principles on reliability for structures — List of equivalent terms*.
- [4] ISO/IEC Guide 2:1991, *General terms and their definitions concerning standardization and related activities*.

This page intentionally left blank

This page intentionally left blank

This page intentionally left blank

UDC 669.14.018.29-122-427:672.85:691.328

Descriptors: concrete, reinforced concrete, reinforcing steels, welded wire lattice, iron and steel products, cold drawn products, wire, specifications, dimensions, mechanical properties, chemical composition, tests, designation, marking, certification.

Price based on 10 pages
