

INTERNATIONAL
STANDARD

ISO
10518

First edition
1991-04-15

Corrected and reprinted
1991-12-15

**Powered walk-behind and hand-held lawn
trimmers and lawn edge trimmers — Mechanical
safety requirements and test methods**

*Coupe-bordures et coupe-gazon portables à la main et à conducteur à
pied — Prescriptions de sécurité mécanique et méthodes d'essai*



Reference number
ISO 10518:1991(E)

Foreword

ISO (the International Organization for Standardization) is a worldwide federation of national standards bodies (ISO member bodies). The work of preparing International Standards is normally carried out through ISO technical committees. Each member body interested in a subject for which a technical committee has been established has the right to be represented on that committee. International organizations, governmental and non-governmental, in liaison with ISO, also take part in the work. ISO collaborates closely with the International Electrotechnical Commission (IEC) on all matters of electrotechnical standardization.

Draft International Standards adopted by the technical committees are circulated to the member bodies for voting. Publication as an International Standard requires approval by at least 75 % of the member bodies casting a vote.

International Standard ISO 10518 was prepared by Technical Committee ISO/TC 23, *Tractors and machinery for agriculture and forestry*, Subcommittee SC 13, *Powered lawn and garden equipment*.

Annex A forms an integral part of this International Standard.

© ISO 1991

All rights reserved. No part of this publication may be reproduced or utilized in any form or by any means, electronic or mechanical, including photocopying and microfilm, without permission in writing from the publisher.

International Organization for Standardization
Case Postale 56 • CH-1211 Genève 20 • Switzerland

Printed in Switzerland

Powered walk-behind and hand-held lawn trimmers and lawn edge trimmers — Mechanical safety requirements and test methods

1 Scope

This International Standard specifies mechanical safety requirements and test methods applicable to powered walk-behind and hand-held lawn trimmers and lawn edge trimmers, with cutting element(s) of non-metallic filament line or freely pivoting non-metallic cutter(s) with a kinetic energy of not more than 10 J each, used by a standing operator primarily for cutting grass.

It does not apply to scissor-type or rigid-bladed lawn trimmers or lawn edge trimmers.

The electrical aspects of electrically powered lawn trimmers and lawn edge trimmers having a voltage exceeding 42 V d.c. or mains-connected are not covered by this International Standard.

2 Normative references

The following standards contain provisions which, through reference in this text, constitute provisions of this International Standard. At the time of publication, the editions indicated were valid. All standards are subject to revision, and parties to agreements based on this International Standard are encouraged to investigate the possibility of applying the most recent editions of the standards indicated below. Members of IEC and ISO maintain registers of currently valid International Standards.

ISO 5395:1990, *Power lawn-mowers, lawn tractors, lawn and garden tractors, professional mowers, and lawn and garden tractors with mowing attachments — Definitions, safety requirements and test procedures.*

IEC 335-1:1976, *Safety of household and similar electrical appliances — Part 1: General requirements.*

3 Definitions

For the purposes of this International Standard, the following definitions apply.

3.1 hand-held: Supported by hand, possibly assisted by wheel(s), skids or harness, etc.

3.2 walk-behind: Normally controlled by an operator walking behind a ground-supported unit.

3.3 lawn trimmer: Grass-cutting machine where the cutting means operates in a plane approximately parallel to the ground.

3.4 lawn edge trimmer: Grass-cutting machine for trimming lawn edges where the cutting means operates in a plane approximately perpendicular to the ground.

3.5 cutting means: Mechanism used to provide the cutting action in which one or more cutting elements, cutting by impact, rotate about an axis normal to the cutting plane.

3.6 cutting element: Single non-metallic filament line or freely pivoting non-metallic cutter.

3.7 drive unit: System which supports and powers the cutting means.

4 General construction

4.1 Handling

The machine shall be capable of normal use by an operator wearing gloves.

Any harness provided shall be of the quick-release type to ensure that the equipment can be quickly detached by the operator in an emergency.

Hand-held lawn trimmers and lawn edge trimmers, or the hand-held parts of such machines, with a mass of more than 5 kg shall have two handles. The distance between the centre of the two handles shall be at least 250 mm, when measured along the length of the handle support shaft. This measurement does not apply to two-handed lawn trimmers weighing 5 kg or less. The machine mass is determined with all accessories fitted and either with any tanks needed for operation half-full, or with 1 m of supply cable, as appropriate.

The gripping width of any handle required by this International Standard shall be at least 100 mm.

4.2 Power-driven components (other than cutting means)

Power-driven gears, chains, sprockets, belts, friction drives, pulleys, fans, fan wheels and other moving parts whenever they create a pinch point capable of causing injury, during normal starting and operating of the machine, shall be so positioned or guarded by shields or similar attachments as to prevent accidental contact with these components. Drive-shafts shall be fully guarded.

The principles set out in annex A of ISO 5395:1990 shall be followed when developing a guarding system.

The requirements of 4.2 do not apply to

- any part of a component functioning in contact with the soil;
- any axle of a ground wheel.

4.3 Heat protection

4.3.1 Temperature limits of exposed parts

A guard or shield shall be provided to prevent inadvertent contact with any exposed engine exhaust component, greater than 10 cm² and with a hot surface greater than 80 °C, during normal starting and operation of the machine.

Handles and permanently held controls shall not exceed 45 °C; other controls and surfaces which may be touched during normal operation shall not exceed 55 °C.

4.3.2 Test method

The test shall be conducted in the shade. The engine shall be operated at its maximum no-load speed until the temperatures stabilize. All measurements shall be referred to an ambient temperature of 20 °C ± 3 °C. Temperatures shall be determined by

correcting the observed temperature by the difference between the specified ambient and the test ambient temperature.

4.3.3 Test acceptance for exhaust surfaces

The tip or conical surface of the cone shown in figure 1 shall not make contact with a hot surface of the exhaust system greater than 10 cm² with a temperature greater than 80 °C.

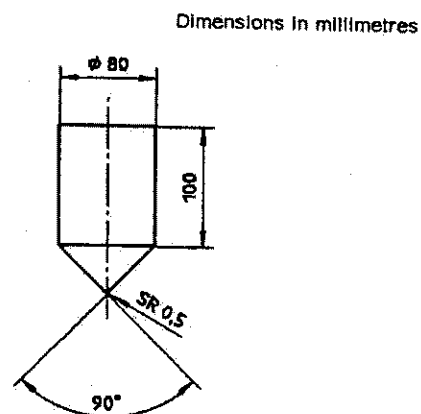

Figure 1 — Test cone (see 4.3.3)

4.4 Guard attachment

All guards or shields required under 4.2 and 4.3 shall be either permanently attached, or secured to prevent removal without the use of tools, or the construction of the machine shall be such that it cannot be used without the guard in its guarding position.

4.5 Protection from exhaust fumes

Engine exhausts shall be directed away from the operator.

4.6 Electrical requirements

4.6.1 Battery circuits

These electrical requirements apply only to battery circuits of less than 42 V. For the electrical requirements for mains-connected electrically driven machines, reference shall be made to IEC 335-1.

4.6.1.1 Electrical cables

Electrical cables shall be protected, or not located near any hot surfaces or in potentially abrasive contact with metal surfaces.

The wiring assembly shall, where possible, be grouped together, be properly supported and be located so that no portion is near the exhaust system or in contact with the carburettor, metallic fuel lines, moving parts or sharp edges. Any edges of metal members likely to be in contact with the cables shall be rounded or protected to prevent possible damage to the cables by cutting or abrasion.

4.6.1.2 Battery installation

The compartment for a vented storage battery shall have openings to provide ventilation and drainage. When the battery is in the operating position, electrolyte shall not leak onto parts that would be critically affected to the extent that a hazard would be created from corrosion.

4.6.1.3 Overload protection

All circuits, except starter-motor and high-voltage ignition circuits, shall be provided with overload protection devices in the ungrounded line near the battery terminal or starter cable. The overload protection may be located in either wire of a two-wire system.

This requirement shall not, however, apply to battery-powered machines capable of passing the following test.

With the motor shaft locked to prevent rotation, connect it to its fully charged integral battery and leave it in that condition until the battery is discharged or failure of any component takes place. The machine shall not emit flames or molten metal. Any internal explosion shall be contained so as not to cause any material to be ejected from the machine.

4.6.1.4 Terminals and uninsulated electrical parts

Terminals and uninsulated electrical parts and two-wire non-grounded systems shall be protected against short-circuiting by the fuel can, or tools, during normal refuelling and lubrication servicing.

4.6.2 Ignition circuits

4.6.2.1 Ignition interruption or short-circuiting shall be provided and shall be fitted on the low-voltage side.

4.6.2.2 All high-voltage parts of the circuit including spark-plug terminals shall be protected or insulated in such a manner that the operator cannot make accidental contact with them.

4.7 Engine stopping and starting

4.7.1 A shut-off control device shall be provided on all battery-powered units and engine-powered units with battery starters to stop the engine (motor). This device shall require manual and intentional activation in order to restart the engine and shall be accessible from the starting and operating positions.

4.7.2 On internal combustion engine driven machines, a means shall be provided to stop the engine. The stopping device shall not depend on sustained manual pressure. For those machines which have a harness, the stop control shall be in the handle area.

4.8 Controls

4.8.1 Requirement

For electrically powered machines, a control shall be provided and this shall require two separate and dissimilar actions before the cutting elements can be driven. There shall be no means of locking this control in the "on" position and the movement of the cutting element shall stop when the control is released.

For internal combustion engine powered machines, the throttle trigger shall be operable without taking the hand off the handle. The throttle trigger shall return to the engine idle position after release. A throttle lock-on (if required for engine starting) shall automatically disengage when the throttle trigger is activated.

4.8.2 Identification of controls

Controls, other than those whose purpose is obvious, shall have the function, direction and method of operation clearly identified with durable marking.

Easily understood detailed instructions on the operation of all controls shall be provided in an operator's manual.

5 Marking

5.1 General

5.1.1 Every machine shall be marked to identify the manufacturer, model number and/or serial number together with appropriate warnings (e.g. fuel type and mixture, recommendation to wear ear protection, distance warning for bystanders, read the owner's manual, etc., as may be necessary).

5.1.2 Every machine shall be prominently marked with the warning "Wear eye protection" or with the appropriate ISO symbol.

5.1.3 If the drive unit is designed to be replaceable or interchangeable, it shall be marked with the manufacturer's identification.

5.1.4 Every lawn trimmer guarded in accordance with 8.1 only shall be permanently marked with a warning, "Do not use for lawn edge trimming".

5.1.5 Marking shall be legible and durable (see 5.3).

5.2 Labels

5.2.1 Labels provided for identification, and directional and cautionary information shall have a reasonable life for the anticipated machine operating environment and satisfy the following requirements:

- a) the label shall have a durable bond with the base surface material;
- b) the label shall be weather-resistant and under normal cleaning procedures shall not fade, discolour, crack or blister, and shall remain legible;
- c) the label shall not curl at the edges and legibility shall not be affected by spilled petrol or oil;
- d) the label, other than those on electrical machines, shall withstand high-pressure cold water cleaning.

See 5.3 for the test method.

5.2.2 Labels giving cautionary information shall be located close to the relevant hazard. Such labels shall be in the official language(s) of the country in which the lawn trimmer is sold. Appropriate ISO symbols may be used.

5.3 Test method

The marking shall be rubbed by hand for 15 s with a piece of cloth soaked with water and again for 15 s with a piece of cloth soaked with petrol.

After the test, the marking shall be easily legible; it shall not be easily possible to remove any labels and they shall show no curling.

6 Instructions

Instructions for correct assembly, safe operation and maintenance shall be provided giving information on at least the following:

- a) requirement to wear eye protection;
- b) identification of correct fuel or fuel/oil mixture to be used;

- c) correct and safe operation and limitations of use;
- d) method of changing cutting elements and drive units (where necessary);
- e) warning against injury from filament line length trimming blades (if applicable);
- f) advice on wearing protective equipment (e.g. gloves, trousers, substantial footwear, ear protection, etc.);
- g) where symbols are used in the marking, their function shall be explained.

The instructions for correct and safe operation and limitations of use should be such as presented in annex A.

7 Cutting means

7.1 A cutting means shall consist of one or more non-metallic cutting elements mounted on or emerging from a generally circular drive unit.

7.2 A cutting element shall consist of one of the following:

- a) a non-metallic freely pivoting cutter; or
- b) a non-metallic filament line.

A cutting element shall have a kinetic energy of not more than 10 J.

For the purposes of this International Standard, the kinetic energy, E_k , in joules, shall be determined by the following formula:

$$E_k = \frac{1}{2}mv^2$$

where

m is the mass, in kilograms, of the cutting element from the pivot point for cutters or from where it emerges from the drive unit for a filament line;

v is the maximum attainable velocity, in metres per second, of the cutting element measured at a point midway between the pivot point for cutters, or the point where it emerges from the drive unit for filament lines, and the end of the cutting element.

Machines having cutting means using one or more cutting elements of continuous filament line (e.g. wound on a spool contained either in the drive unit or other attachment) shall have incorporated a means to limit the line automatically to its correct

operating length after the line has been extended and/or the machine is operated.

7.3 A cutting element shall not be replaceable with metallic cutting elements available from the manufacturer.

8 Guarding of cutting means

8.1 Lawn trimmers

Lawn trimmers shall be guarded on the operator's side, as a minimum, to the extent shown in figure 2.

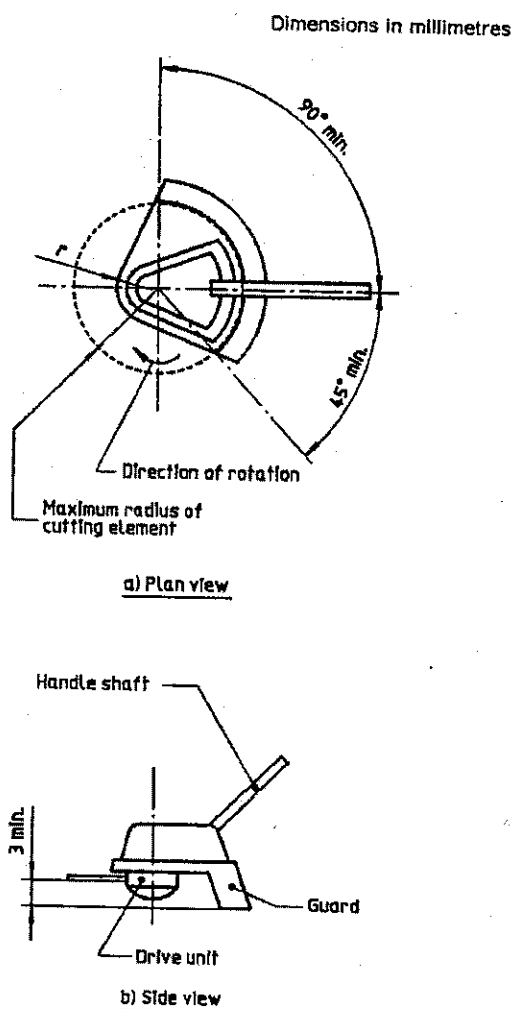

Figure 2 — Lawn trimmer guard (see 8.1)

NOTES

1 For reasons of clarity, any skids or wheels are not shown in figure 2. The figure is not intended to govern design except as regards the dimensions and specific requirements prescribed below.

2 Figures are not to scale.

The radius r of the guard shall not be smaller than the major swept radius of the drive unit.

The guard shall extend beyond the plane of the cutting element by at least 3 mm.

The guard shall extend at least 45° from the axis of the handle shaft on the side where the cutting element is moving away from the operator and at least 90° from the axis of the handle shaft on the side where the cutting element is moving towards the operator. The vertex of the angle is the axis of the drive unit spindle.

Figure 2a) shows clockwise rotation of the cutting element. If the direction of rotation is reversed, the 45° and 90° guard extensions shall be transposed.

If the guarding is less than a total of 360°, the direction of rotation of the cutting elements shall be marked on the machine.

8.2 Lawn edge trimmers

Lawn edge trimmers shall be guarded, as a minimum, to the extent shown in figure 3.

Dimensions in millimetres

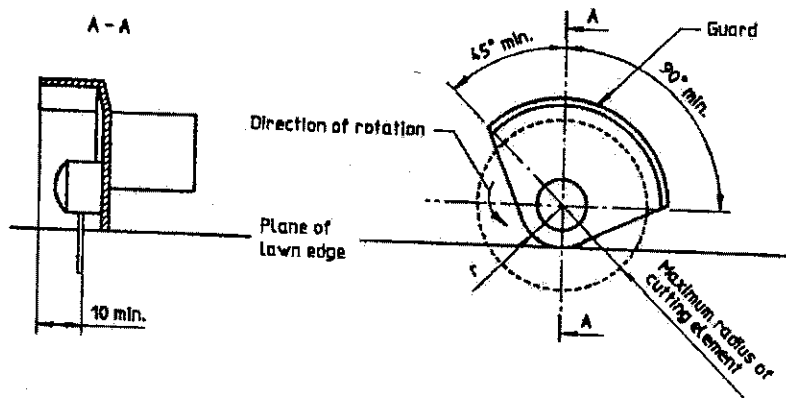

Figure 3 — Lawn edge trimmer guard (see 8.2)

NOTES

3 For reasons of clarity, any skids or wheels are not shown on the figure. The figure is not intended to govern design except as regards the dimensions and specific requirements prescribed below.

4 Figures are not to scale.

The radius r of the guard shall not be smaller than the major swept radius of the drive unit.

The guard shall extend beyond the plane of the cutting element by at least 10 mm.

With the lawn edge trimmer in its normal position of use, the guard shall extend a minimum of 90° from the vertical towards the ground on the side where the cutting element is moving upwards and a minimum of 45° from the vertical towards the ground on the side where the cutting element is moving downwards. The vertex of the angle is the axis of the drive unit spindle.

8.3 Guard fixing

Guards shall not be detachable without the use of a tool.

9 Mechanical strength and rigidity

All the tests in clause 9 shall be carried out when the temperature of parts to be tested has settled to an ambient temperature of $25\text{ °C} \pm 5\text{ °C}$.

9.1 Cutting means guard

9.1.1 The mechanical strength and rigidity of cutting means guards of walk-behind and hand-held lawn trimmers and lawn edge trimmers shall be checked by the tests in 9.1.1.1, and 9.1.1.2 or 9.1.1.3.

9.1.1.1 Apply a force, at any point, equivalent to the weight of the lawn trimmer in the most unfavourable direction for 30 s, to check the rigidity of the guard.

During the test, the guard shall not distort to the extent that the requirements of 8.1 or 8.2 are not met, and screws and retaining clips shall remain secure.

9.1.1.2 Test the strength of guards of walk-behind lawn trimmers and lawn edge trimmers by means of a ball impact test on the part of the guard likely to be the weakest, with the lawn trimmer resting on a smooth, rigid, level surface.

Conduct the ball impact test with a smooth steel sphere having a diameter of 50 mm and weighing 0,45 kg. If the part being tested is at an angle of up to 45° to the horizontal, allow the sphere to fall vertically from rest to strike the part. Otherwise, suspend the sphere by means of a length of string and allow it to fall from rest as a pendulum to strike the part. In either case, the vertical travel of the sphere shall be 1,3 m.

After the tests, the guard shall not have become detached nor show any visible cracks. Screws and retaining clips shall still be secure and the requirements of 8.1 or 8.2 shall still be met.

9.1.1.3 The strength of guards of hand-held lawn trimmers and lawn edge trimmers shall be tested by means of a drop test.

Drop each of three samples of the complete machine three times so that the guard falls through a vertical distance of 0,9 m onto a smooth horizontal concrete surface in such a manner as to test the guard most severely. (See figure 4.)

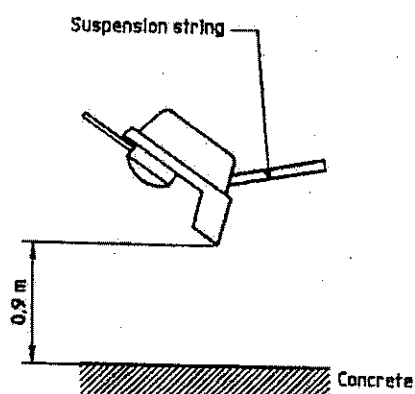

Figure 4 — Guard strength test (see 9.1.1.3)

For the test, a length of suspension string should be used to suspend the machine so that the desired orientation of the machine can be achieved. Cutting the string will allow the machine to fall in the correct orientation to test the guard.

After the tests the guard shall not have become detached nor show any visible cracks. Screws and retaining clips shall still be secure and the requirements of 8.1 or 8.2 shall still be met.

9.2 Drive unit

The mechanical strength of the drive unit shall be checked by the following test.

Drop the complete machine so that the drive unit, in a horizontal plane, falls through a vertical distance to make contact with a rigidly supported horizontal

steel plate. The drop height shall be 0,9 m for hand-held lawn trimmers and lawn edge trimmers and 0,25 m for walk-behind lawn trimmers and lawn edge trimmers. (See figure 5.)

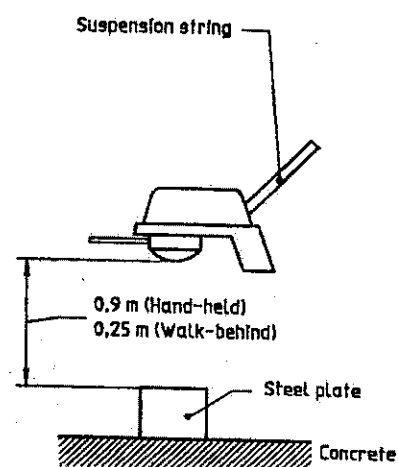

Figure 5 — Drive unit strength test (see 9.2)

For the test, a length of suspension string should be used to suspend the machine so that the desired orientation of the machine can be achieved. Cutting the string will allow the machine to fall in the correct orientation to test the drive unit.

If the machine is operable, then immediately following this test, run the machine at its maximum speed for 30 s both with and without cutting elements. No parts shall become detached and no visible cracks shall develop.

Annex A
(normative)

Safety instructions for walk-behind and hand-held lawn trimmers and lawn edge trimmers

A.1 The instructions for correct and safe operation and limitation of use should be such as those given below:

- a) Read the instructions carefully. Be familiar with the controls and proper use of the equipment.
- b) Wear eye protection.
- c) Never allow children or people unfamiliar with these instructions to use the machine.
- d) Avoid using the machine while people, especially children, or pets are nearby.
- e) Use the machine only in daylight or good artificial light.
- f) Never operate the machine with damaged guards or shields or without guards or shields in place.
- g) Start the engine or switch on the motor carefully with the hands and feet well away from the cutting means.
- h) Never fit metal cutting elements.
- i) Use only manufacturer-recommended replacement parts and accessories.

A.2 In addition, for lawn trimmers guarded in accordance with 8.1 only:

- j) Do not use for lawn edge trimming.

A.3 In addition, for petrol-powered machines:

j) **WARNING** — Petrol is highly flammable. Take the following precautions:

- 1) Store fuel in containers specifically designed for this purpose.

- 2) Refuel outdoors only and do not smoke while refuelling or operating the machine.

- 3) Ensure correct fuel or fuel/oil mixture is used. Add fuel before starting work. Never operate the machine without the fuel cap securely in place. Never remove the cap of the fuel tank or add fuel when the engine is running or when the engine is hot.

- 4) If petrol is spilled, do not attempt to start the engine but move the machine away from the area of spill and avoid creating any source of ignition until petrol vapours have dissipated.

- k) Stop the engine whenever leaving the machine, before refuelling and when adjusting the cutting element.

- l) Stop the engine before checking, cleaning or working on the machine.

- m) Allow the engine to cool before storing in any enclosure.

- n) Never store the machine with petrol in the tank inside a building where fumes may reach an open flame or spark.

- o) To reduce fire hazard, keep the engine and silencer free of grass, leaves or excessive grease.

- p) Do not change the engine governor settings or overspeed the engine.

- q) Replace faulty silencers and spark arrestors, if fitted.

A.4 In addition, for electric motor powered machines:

- j) Those instructions and warnings required to comply with IEC 335-1.

ISO 10518:1991(E)

UDC 631.352

Descriptors: agricultural machinery, horticultural machinery, power horticultural machinery, lawn trimmers, specifications, safety requirements, tests, marking, labelling.

Price based on 8 pages
