**Prevailing torque type all-metal hexagon
high nuts with metric fine pitch thread —
Property classes 8, 10 and 12**

*Écrous hexagonaux hauts autofreinés tout métal à filetage métrique à
pas fin — Classes de qualité 8, 10 et 12*





COPYRIGHT PROTECTED DOCUMENT

© ISO 2012

All rights reserved. Unless otherwise specified, no part of this publication may be reproduced or utilized in any form or by any means, electronic or mechanical, including photocopying and microfilm, without permission in writing from either ISO at the address below or ISO's member body in the country of the requester.

ISO copyright office
Case postale 56 • CH-1211 Geneva 20
Tel. + 41 22 749 01 11
Fax + 41 22 749 09 47
E-mail copyright@iso.org
Web www.iso.org

Published in Switzerland

Contents

Page

Foreword	iv
1 Scope	1
2 Normative references	1
3 Dimensions	2
4 Requirements and reference International Standards	3
5 Designation	3
Bibliography	4

Foreword

ISO (the International Organization for Standardization) is a worldwide federation of national standards bodies (ISO member bodies). The work of preparing International Standards is normally carried out through ISO technical committees. Each member body interested in a subject for which a technical committee has been established has the right to be represented on that committee. International organizations, governmental and non-governmental, in liaison with ISO, also take part in the work. ISO collaborates closely with the International Electrotechnical Commission (IEC) on all matters of electrotechnical standardization.

International Standards are drafted in accordance with the rules given in the ISO/IEC Directives, Part 2.

The main task of technical committees is to prepare International Standards. Draft International Standards adopted by the technical committees are circulated to the member bodies for voting. Publication as an International Standard requires approval by at least 75 % of the member bodies casting a vote.

Attention is drawn to the possibility that some of the elements of this document may be the subject of patent rights. ISO shall not be held responsible for identifying any or all such patent rights.

ISO 10513 was prepared by Technical Committee ISO/TC 2, *Fasteners*, Subcommittee SC 12, *Fasteners with metric internal thread*.

This second edition cancels and replaces the first edition (ISO 10513:1997), of which it constitutes a minor revision.

Prevailing torque type all-metal hexagon high nuts with metric fine pitch thread — Property classes 8, 10 and 12

1 Scope

This International Standard specifies the characteristics of prevailing torque type all-metal hexagon high nuts with metric fine pitch thread, with nominal thread diameters, D , from 8 mm up to and including 36 mm, in product grade A for sizes D up to and including 16 mm and product grade B for sizes D above 16 mm, and with property classes 8, 10 and 12.

NOTE The dimensions of the nuts with the exception of the dimensions m_w and h_{max} correspond to those given in ISO 8674.

If other specifications are required, they can be selected from existing International Standards, for example ISO 261, ISO 724, ISO 898-2, ISO 965-2, ISO 2320 and ISO 4759-1.

2 Normative references

The following documents, in whole or in part, are normatively referenced in this document and are indispensable to its application. For undated references, the latest edition of the referenced document (including any amendments) applies.

ISO 225, *Fasteners — Bolts, screws, studs and nuts — Symbols and descriptions of dimensions*

ISO 261, *ISO general purpose metric screw threads — General plan*

ISO 724, *ISO general-purpose metric screw threads — Basic dimensions*

ISO 898-2, *Mechanical properties of fasteners made of carbon steel and alloy steel — Part 2: Nuts with specified property classes — Coarse thread and fine pitch thread*

ISO 965-2, *ISO general purpose metric screw threads — Tolerances — Part 2: Limits of sizes for general purpose external and internal screw threads — Medium quality*

ISO 2320, *Prevailing torque type steel nuts — Mechanical and performance properties*

ISO 3269, *Fasteners — Acceptance inspection*

ISO 4042, *Fasteners — Electroplated coatings*

ISO 4759-1, *Tolerances for fasteners — Part 1: Bolts, screws, studs and nuts — Product grades A, B and C*

ISO 6157-2, *Fasteners — Surface discontinuities — Part 2: Nuts*

ISO 8992, *Fasteners — General requirements for bolts, screws, studs and nuts*

ISO 10683, *Fasteners — Non-electrolytically applied zinc flake coatings*

3 Dimensions

See Figure 1 and Table 1.

Symbols and descriptions of dimensions are specified in ISO 225.

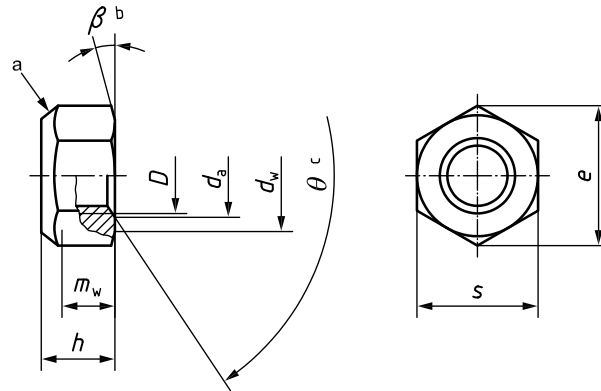

- a Prevailing torque element; shape at the discretion of the manufacturer.
- b $\beta = 15^\circ$ to 30° .
- c $\theta = 90^\circ$ to 120° .

Figure 1

Table 1 — Dimensions

Dimensions in millimetres

Thread ($D \times P^a$)		M8×1	M10×1 M10×1,25	M12×1,25 M12×1,5	(M14×1,5) ^b	M16×1,5	M20×1,5	M24×2	M30×2	M36×3
d_a	max.	8,75	10,80	13,00	15,10	17,30	21,60	25,90	32,40	38,90
	min.	8,00	10,00	12,00	14,00	16,00	20,00	24,00	30,00	36,00
d_w	min.	11,63	14,63	16,63	19,64	22,49	27,70	33,25	42,75	51,11
e	min.	14,38	17,77	20,03	23,36	26,75	32,95	39,55	50,85	60,79
h	max.	8,00	10,00	13,30	14,10	16,40	20,30	23,90	30,00	36,00
	min.	7,14	8,94	11,57	13,40	15,70	19,00	22,60	27,30	33,10
m_w	min.	5,15	6,43	8,30	9,68	11,28	13,52	16,16	19,44	23,52
s	max.	13,00	16,00	18,00	21,00	24,00	30,00	36,00	46,00	55,00
	min.	12,73	15,73	17,73	20,67	23,67	29,16	35,00	45,00	53,80

^a P is the pitch of the thread.

^b The size in parentheses should be avoided if possible.

4 Requirements and reference International Standards

See Table 2.

Table 2 — Requirements and reference International Standards

Material		Steel
General requirements	International Standard	ISO 8992
Thread	Tolerance class	6H
	International Standards	ISO 261, ISO 724, ISO 965-2
Mechanical and performance properties	Property class	8, 10, 12 ^a
	International Standards	ISO 898-2, ISO 2320
Tolerance	Product grade	For $D \leq 16$ mm: A For $D > 16$ mm: B
	International Standard	ISO 4759-1
Finish — Coating		As processed Requirements for electroplating are specified in ISO 4042. Requirements for non-electrolytically applied zinc flake coatings are specified in ISO 10683. Additional requirements or other finishes or coatings shall be agreed between the supplier and the purchaser.
Surface integrity		Limits for surface discontinuities are specified in ISO 6157-2.
Acceptability		Acceptance inspection is specified in ISO 3269.
^a For $D > 16$ mm property class 12 is not specified.		

5 Designation

EXAMPLE A prevailing torque type all-metal hexagon high nut with fine pitch thread $M12 \times 1,5$ and property class 8 is designated as follows:

Prevailing torque type hexagon high nut ISO 10513 - M12 × 1,5 - 8

Bibliography

- [1] ISO 8674, *Hexagon high nuts (style 2) with metric fine pitch thread — Product grades A and B*

ICS 21.060.20

Price based on 4 pages