

# INTERNATIONAL STANDARD

**ISO**  
**10500**

First edition  
1991-11-15

---

---

## **Industrial tyres and rims — Cylindrical and conical base rubber solid tyres (metric series) — Designation, dimensions and marking**

*Pneumatiques et jantes pour matériel de manutention — Bandages  
pleins en caoutchouc à base conique ou cylindrique (série  
millimétrique) — Désignation, dimensions et marquage*



Reference number  
ISO 10500:1991(E)

**ISO 10500:1991(E)****Foreword**

ISO (the International Organization for Standardization) is a worldwide federation of national standards bodies (ISO member bodies). The work of preparing International Standards is normally carried out through ISO technical committees. Each member body interested in a subject for which a technical committee has been established has the right to be represented on that committee. International organizations, governmental and non-governmental, in liaison with ISO, also take part in the work. ISO collaborates closely with the International Electrotechnical Commission (IEC) on all matters of electrotechnical standardization.

Draft International Standards adopted by the technical committees are circulated to the member bodies for voting. Publication as an International Standard requires approval by at least 75 % of the member bodies casting a vote.

International Standard ISO 10500 was prepared by Technical Committee ISO/TC 31, *Tyres, rims and valves*, Sub-Committee SC 7, *Industrial tyres and rims*.

© ISO 1991

All rights reserved. No part of this publication may be reproduced or utilized in any form or by any means, electronic or mechanical, including photocopying and microfilm, without permission in writing from the publisher.

International Organization for Standardization  
Case Postale 56 • CH-1211 Genève 20 • Switzerland

Printed in Switzerland

# Industrial tyres and rims — Cylindrical and conical base rubber solid tyres (metric series) — Designation, dimensions and marking

## 1 Scope

This International Standard specifies the main requirements, including designations, dimensions, markings and load ratings, of the metric series of cylindrical and conical base rubber solid tyres primarily intended for industrial machines for use on prepared surfaces.

## 2 Normative references

The following standards contain provisions which, through reference in this text, constitute provisions of this International Standard. At the time of publication, the editions indicated were valid. All standards are subject to revision, and parties to agreements based on this International Standard are encouraged to investigate the possibility of applying the most recent editions of the standards indicated below. Members of IEC and ISO maintain registers of currently valid International Standards.

ISO 286-2:1988, *ISO system of limits and fits — Part 2: Tables of standard tolerance grades and limit deviations for holes and shafts.*

ISO 468:1982, *Surface roughness — Parameters, their values and general rules for specifying requirements.*

ISO 3877-4:1984, *Tyres, valves and tubes — List of equivalent terms — Part 4: Solid tyres.*

ISO 4223-2:1991, *Definitions of some terms used in the tyre industry — Part 2: Solid tyres.*

## 3 Definitions

For definitions of terms relating to solid tyres, see ISO 4223-2:1991; equivalent terms are given in ISO 3877-4:1984.

## 4 Tyre designations

The dimensional and constructional characteristics shall be indicated as specified in 4.1 and 4.2.

### 4.1 Cylindrical base tyres

#### 4.1.1 Pressed-on tyres

A three-part designation shall be given, as follows:

overall diameter  $D$  × nominal base width  $W$  -  
nominal rim (wheel) diameter  $d$

EXAMPLE

**260 × 125-160**

#### 4.1.2 Cured-on tyres

A two-part designation shall be given, as follows:

overall diameter  $D$  × nominal base width  $W$

EXAMPLE

**225 × 100**

### 4.2 Conical base tyres

A four-part designation shall be given, as follows:

overall diameter  $D$  × nominal tyre width  $W$  -  
nominal rim (wheel) diameter  $d_0$ , with the symbol  
KM (for a wheel divided in the middle) or KS (for  
a wheel divided at the side)

EXAMPLE

**260 × 125-160 KM**

## ISO 10500:1991(E)

**5 Marking****5.1 General marking**

The marking shall consist of the designation specified in clause 4.

The location of the marking of the symbols KM or KS for conical base tyres may be distinct but shall be in close proximity to the marking of the other dimensional characteristics.

**5.2 Maximum speed marking**

If a tyre is not capable of operating at the maximum speeds shown in table 4, its actual maximum speed shall be marked on the sidewall of the tyre.

**6 Tyre dimensions**

The relevant dimensions for the recommended size range of metric series of cylindrical and conical base rubber solid tyres are shown in table 1.

**7 Rims****7.1 Rim (wheel) profiles for cylindrical base tyres**

**7.1.1** The dimensional data of the rims (wheels) are given in figure 1 and table 1.

**7.1.2** The rim (wheel) diameter tolerances shall be h11, as defined in ISO 286-2.

**7.1.3** The mating surface roughness shall have an arithmetical mean deviation,  $R_a$ , as defined in ISO 468, not exceeding  $6,3 \mu\text{m}$ .

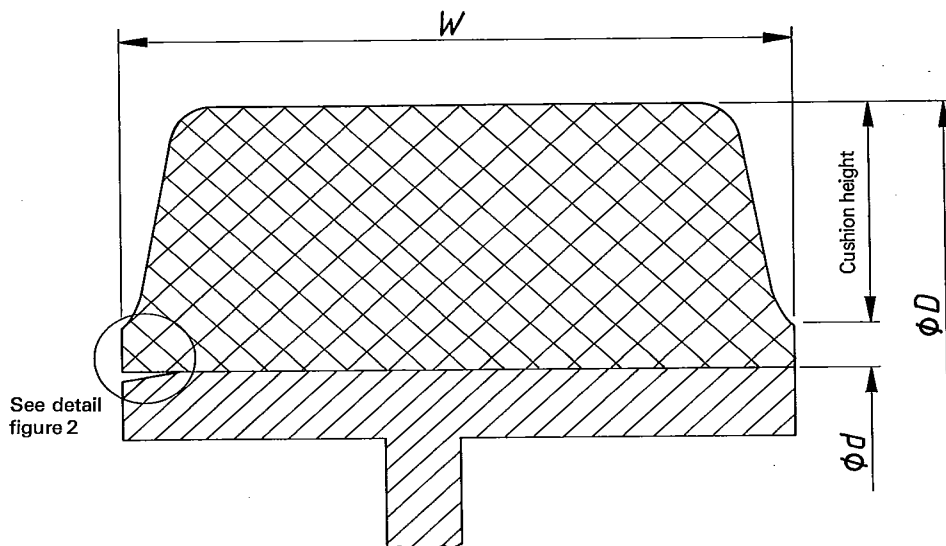

**Figure 1 — Cylindrical base solid tyre**

**Table 1 — Dimensions for cylindrical and conical base solid tyres**

Dimensions in millimetres

Nominal rim (wheel) diameter <i>d</i> or <i>d</i> <sub>0</sub> <sup>3)</sup>	Tyre base widths, <i>W</i> <sup>1)</sup>						Cushion height of cylindrical base solid tyres <sup>2)</sup> $\frac{D - d}{2} - 10$
	100	125	160	200	250	300	
	Overall diameters, <i>D</i>						
125	225						40
160	260	260					40
200	320	320	320				50
270	390	390	390	390			50
315	455	455	455	455	455		60
410	560	560	560	560	560	560	65
500		650	650	650	650	650	65
670			820	820	820	820	65

- 1) The maximum tyre overall diameter and base width in service shall not exceed the design values.
- 2) Cushion height is calculated on the assumption of a base band of 10 mm thickness.
- 3) *d* applies to cylindrical base; *d*<sub>0</sub> to conical base.

7.1.4 To facilitate tyre mounting, at least one side of the rim (wheel) shall be bevelled (see figure 2). Dimensions in table 2 are recommended.

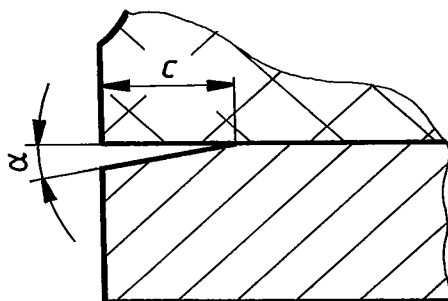

**Figure 2 — Rim beveling**

**Table 2 — Rim beveling**

Tyre base width, <i>W</i> mm	Width of beveling, <i>c</i> mm	Angle to axis, $\alpha$
<i>W</i> = 100	3	30° ± 5°
<i>W</i> ≥ 125	5	

**7.2 Rim (wheel) profiles for conical base tyres**

7.2.1 The dimensional data for the rims (wheels) are given in figure 3 and table 3.

7.2.2 The rim (wheel) diameter tolerances for *d*<sub>0</sub>, *d*<sub>1</sub> and *d*<sub>2</sub> shall be js12 as defined in ISO 286-2.

**8 Load ratings**

8.1 Tyre load-carrying capacities on counterbalanced fork-lift trucks and on other vehicles are specified in table 4.

8.2 Load capacities are based on cylindrical base tyre dimensions. They are independent from the thickness of the cylindrical tyre base band.

8.3 Load capacities for cylindrical base and conical base tyres are the same.

8.4 When fitted in dual formation, the load capacity for the two tyres is twice that for a single tyre.

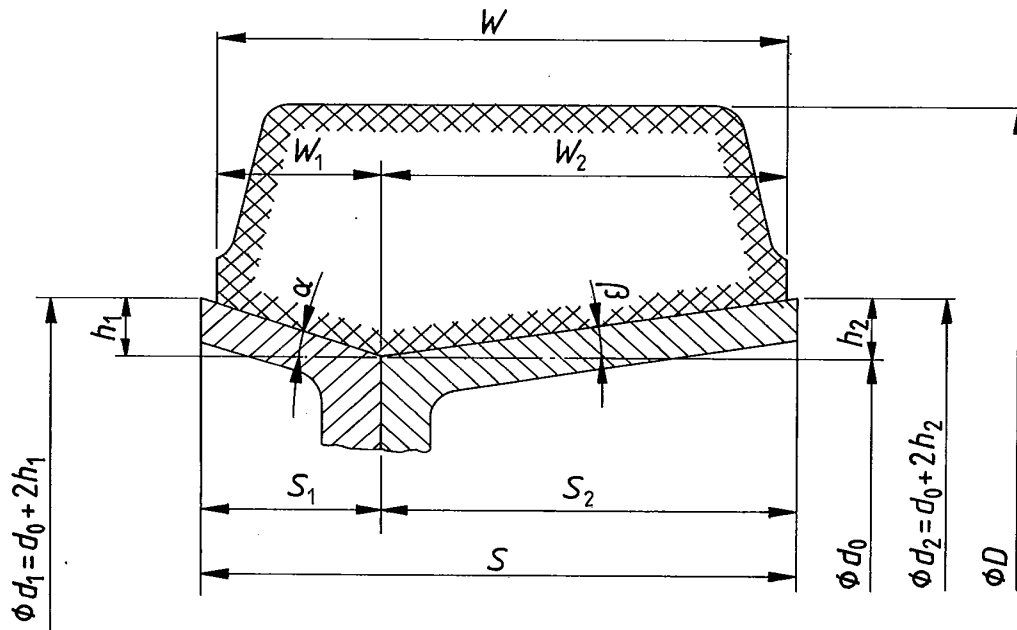

$d_0$  = rim diameter;  $D$  = overall diameter

Figure 3 — Rim profiles for conical-base solid tyres

Table 3 — Rim profiles for conical-base solid tyres

Dimensions in millimetres, angles in degrees

Tyre width $W$	Rim width $S$	Rim angles		Symbol <sup>1)</sup>	Widths				Rim height	
		$\alpha$	$\beta$		$W_1$	$W_2$	$S_1$	$S_2$	$h_1$	$h_2$
100	104	8	8	KM	50	50	52	52	7,3	7,3
125	130	8	8	KM	62,5	62,5	65	65	9,1	9,1
160	167	15	8	KS	45	115	48,5	118,5	13,0	12,4
200	208	15	8	KS	69	131	73	135	19,6	19,0
250	260	15	8	KS	86	164	91	169	24,5	23,7
300	312	15	8	KS	103	197	109	203	29,2	28,5

1) This symbol shall be shown on the tyre in close proximity to the marking of the dimensional characteristics (see 5.1).

Table 4 — Tyre load capacity ratings per tyre for cylindrical and conical base rubber solid tyres

Tyre size		Tyre load capability on counterbalanced fork lift trucks of speed capabilities				Tyre load capability on other vehicles of speed capabilities up to 16 km/h kg
		up to 10 km/h		up to 16 km/h		
		Pressed-on tyres	Cured-on tyres	Load wheels kg	Steering wheels kg	
225 × 100-125	225 × 100	700	575	625	525	500
260 × 100-160	260 × 100	780	640	700	585	560
260 × 125-160	260 × 125	1 030	845	920	775	735
320 × 100-200	320 × 100	915	750	815	685	655
320 × 125-200	320 × 125	1 230	1 010	1 095	920	880
320 × 160-200	320 × 160	1 670	1 370	1 490	1 250	1 190
390 × 100-270	390 × 100	1 060	870	950	795	760
390 × 125-270	390 × 125	1 425	1 170	1 275	1 070	1 020
390 × 160-270	390 × 160	1 935	1 590	1 730	1 450	1 380
390 × 200-270	390 × 200	2 515	2 065	2 245	1 890	1 800
455 × 100-315	455 × 100	1 175	965	1 045	880	835
455 × 125-315	455 × 125	1 605	1 320	1 435	1 205	1 145
455 × 160-315	455 × 160	2 215	1 820	1 975	1 660	1 580
455 × 200-315	455 × 200	2 905	2 390	2 595	2 180	2 075
455 × 250-315	455 × 250	3 775	3 100	3 370	2 830	2 695
560 × 100-410	560 × 100	1 350	1 110	1 205	1 015	965
560 × 125-410	560 × 125	1 870	1 540	1 670	1 405	1 335
560 × 160-410	560 × 160	2 600	2 135	2 320	1 950	1 855
560 × 200-410	560 × 200	3 430	2 820	3 065	2 575	2 450
560 × 250-410	560 × 250	4 470	3 675	3 995	3 355	3 195
560 × 300-410	560 × 300	5 515	4 530	4 920	4 135	3 935
650 × 125-500	650 × 125	2 090	1 720	1 870	1 570	1 495
650 × 160-500	650 × 160	2 910	2 390	2 595	2 180	2 075
650 × 200-500	650 × 200	3 835	3 150	3 425	2 880	2 740
650 × 250-500	650 × 250	5 000	4 110	4 465	3 750	3 570
650 × 300-500	650 × 300	6 165	5 065	5 505	4 625	4 405
820 × 160-670	820 × 160	3 460	2 840	3 090	2 595	2 470
820 × 200-670	820 × 200	4 570	3 750	4 080	3 425	3 260
820 × 250-670	820 × 250	5 955	4 890	5 315	4 465	4 250
820 × 300-670	820 × 300	7 340	6 030	6 550	5 505	5 240

ISO 10500:1991(E)

---

---

**UDC 629.11.012.53:62-182.3**

**Descriptors:** machinery, machine components, tyres, specifications, dimensions, designation, marking, load capacity.

Price based on 5 pages

---

---