

---

---

**Glass-reinforced thermosetting plastics  
(GRP) pipes — Determination of the  
long-term specific ring creep stiffness  
under wet conditions and calculation of  
the wet creep factor**

*Tubes en plastiques thermodurcissables renforcés de verre (PRV) —  
Détermination de la rigidité annulaire spécifique à long terme en fluage  
en conditions mouillées et calcul du facteur de fluage mouillé*



**PDF disclaimer**

This PDF file may contain embedded typefaces. In accordance with Adobe's licensing policy, this file may be printed or viewed but shall not be edited unless the typefaces which are embedded are licensed to and installed on the computer performing the editing. In downloading this file, parties accept therein the responsibility of not infringing Adobe's licensing policy. The ISO Central Secretariat accepts no liability in this area.

Adobe is a trademark of Adobe Systems Incorporated.

Details of the software products used to create this PDF file can be found in the General Info relative to the file; the PDF-creation parameters were optimized for printing. Every care has been taken to ensure that the file is suitable for use by ISO member bodies. In the unlikely event that a problem relating to it is found, please inform the Central Secretariat at the address given below.

© ISO 2003

All rights reserved. Unless otherwise specified, no part of this publication may be reproduced or utilized in any form or by any means, electronic or mechanical, including photocopying and microfilm, without permission in writing from either ISO at the address below or ISO's member body in the country of the requester.

ISO copyright office  
Case postale 56 • CH-1211 Geneva 20  
Tel. + 41 22 749 01 11  
Fax + 41 22 749 09 47  
E-mail [copyright@iso.org](mailto:copyright@iso.org)  
Web [www.iso.org](http://www.iso.org)

Published in Switzerland

# Contents

Page

Foreword .....	iv
<b>1 Scope.....</b>	<b>1</b>
<b>2 Normative references .....</b>	<b>1</b>
<b>3 Terms and definitions .....</b>	<b>1</b>
<b>4 Principle .....</b>	<b>4</b>
<b>5 Apparatus.....</b>	<b>4</b>
5.1 Compressive loading machine .....	4
5.2 Force application surfaces.....	4
5.3 Water container .....	5
5.4 Measuring devices .....	5
<b>6 Test piece.....</b>	<b>5</b>
<b>7 Number of test pieces.....</b>	<b>6</b>
<b>8 Determination of the dimensions of the test pieces .....</b>	<b>6</b>
8.1 Length .....	6
8.2 Wall thickness .....	7
8.3 Mean diameter .....	7
<b>9 Conditioning .....</b>	<b>7</b>
<b>10 Procedure.....</b>	<b>7</b>
<b>11 Calculation .....</b>	<b>8</b>
11.1 Extrapolation of the deflection data .....	8
11.2 Calculation of the long-term specific ring creep stiffness under wet conditions for position 1 .....	8
11.3 Calculation of the wet creep factor .....	8
<b>12 Test report.....</b>	<b>8</b>
<b>Annex A (informative) Equal increments of lg(time in h) .....</b>	<b>10</b>

## Foreword

ISO (the International Organization for Standardization) is a worldwide federation of national standards bodies (ISO member bodies). The work of preparing International Standards is normally carried out through ISO technical committees. Each member body interested in a subject for which a technical committee has been established has the right to be represented on that committee. International organizations, governmental and non-governmental, in liaison with ISO, also take part in the work. ISO collaborates closely with the International Electrotechnical Commission (IEC) on all matters of electrotechnical standardization.

International Standards are drafted in accordance with the rules given in the ISO/IEC Directives, Part 2.

The main task of technical committees is to prepare International Standards. Draft International Standards adopted by the technical committees are circulated to the member bodies for voting. Publication as an International Standard requires approval by at least 75 % of the member bodies casting a vote.

Attention is drawn to the possibility that some of the elements of this document may be the subject of patent rights. ISO shall not be held responsible for identifying any or all such patent rights.

ISO 10468 was prepared by Technical Committee ISO/TC 138, *Plastics pipes, fittings and valves for the transport of fluids*, Subcommittee SC 6, *Reinforced plastics pipes and fittings for all applications*.

# Glass-reinforced thermosetting plastics (GRP) pipes — Determination of the long-term specific ring creep stiffness under wet conditions and calculation of the wet creep factor

## 1 Scope

This International Standard specifies a method for determining both the long-term specific ring creep stiffness and the wet creep factor for glass-reinforced thermosetting plastics (GRP) pipes.

## 2 Normative references

The following referenced documents are indispensable for the application of this document. For dated references, only the edition cited applies. For undated references, the latest edition of the referenced document (including any amendments) applies.

ISO 7685:1998, *Plastics piping systems — Glass-reinforced thermosetting plastics (GRP) pipes — Determination of initial specific ring stiffness*

ISO 10928:1997, *Plastics piping systems — Glass-reinforced thermosetting plastics (GRP) pipes and fittings — Methods for regression analysis and their use*

## 3 Terms and definitions

For the purposes of this document, the following terms and definitions apply.

### 3.1

#### vertical compressive force

$F$

vertical force, expressed in newtons, applied to a horizontal pipe to cause a vertical deflection

### 3.2

#### specific ring stiffness

$S$

physical characteristic of a pipe, expressed in newtons per square metre, that is a measure of the resistance to ring deflection per metre length under external load and is defined by Equation (1):

$$S = \frac{E \times I}{d_m^3} \quad (1)$$

where

$E$  is the apparent modulus of elasticity, in newtons per square metre, determined by testing in accordance with ISO 7685;

$I$  is the second moment of area in the longitudinal direction per metre length, in metres to the fourth power per metre ( $\text{m}^4/\text{m}$ ), i.e.

$$I = \frac{e^3}{12} \quad (2)$$

$e$  being the wall thickness of the pipe, in metres;

$d_m$  is the mean diameter of the pipe, in metres (see 3.3).

**3.3  
mean diameter**

$d_m$   
diameter, expressed in metres, of the circle corresponding with the middle of the pipe wall cross-section and given by either of the following equations:

$$d_m = d_i + e \tag{3}$$

$$d_m = d_e - e \tag{4}$$

where

$d_i$  is the internal diameter, in metres;

$d_e$  is the external diameter, in metres;

$e$  is the wall thickness of the pipe, in metres.

**3.4  
initial specific ring stiffness**

$S_0$   
value of  $S$ , expressed in newtons per square metre, determined by testing in accordance with ISO 7685

**3.5  
long-term specific ring creep stiffness at position 1**

$S_{x, 1, \text{ creep, wet}}$   
value of  $S$ , expressed in newtons per square metre, at a reference position, position 1 (see 10.2), at  $x$  years, obtained by extrapolation of long-term stiffness measurements at a constant force under wet conditions (see 3.2 and 10.2)

**3.6  
calculated long-term specific ring creep stiffness under wet conditions**

$S_{x, \text{ creep, wet}}$   
calculated value of  $S$ , expressed in newtons per square metre, at  $x$  years obtained using Equation (5):

$$S_{x, \text{ creep, wet}} = S_0 \times \alpha_{x, \text{ creep, wet}} \tag{5}$$

where

$x$  is the elapsed time, in years, specified in the referring standard;

$\alpha_{x, \text{ creep, wet}}$  is the wet creep factor (see 3.7);

$S_0$  is the initial specific ring stiffness, in newtons per square metre.

**3.7  
wet creep factor**

$\alpha_{x, \text{ creep, wet}}$   
ratio of the long-term specific ring creep stiffness to the initial specific ring stiffness, both at a reference position, position 1 (see 10.2), and given by Equation (6):

$$\alpha_{x, \text{ creep, wet}} = \frac{S_{x, 1, \text{ creep, wet}}}{S_{0, 1}} \tag{6}$$

where

$S_{0,1}$  is the initial specific ring stiffness at position 1, in newtons per square metre, determined in accordance with ISO 7685;

$S_{x,1, \text{creep, wet}}$  is the long-term specific ring creep stiffness at position 1, in newtons per square metre.

### 3.8

#### vertical deflection

$y$

vertical change in diameter of a pipe in a horizontal position, expressed in metres, in response to a vertical compressive force (see 3.1)

### 3.9

#### long-term vertical deflection

$y_{x,1, \text{wet}}$

value of the vertical deflection  $y$ , expressed in metres, at the reference position, position 1 (see 10.2), at  $x$  years under wet conditions

### 3.10

#### deflection coefficient

$f$

dimensionless factor which takes into account general second-order theory as applied to deflection and is given by Equation (7):

$$f = [1\,860 + (2\,500 \times y_1 / d_m)] \times 10^{-5} \quad (7)$$

where

$y_1$  is the long-term vertical deflection at position 1, in metres;

$d_m$  is the mean diameter (see 3.3) of the pipe, in metres.

### 3.11

#### calculated strain

$\varepsilon_{\text{calc},1}$

strain on the inner surface at the crown and invert of a pipe at the reference position, position 1, given in percent by Equation (8):

$$\varepsilon_{\text{calc},1} = \frac{4,28 \times \frac{e}{d_m} \times \frac{y_1}{d_m} \times 100}{\left(1 + \frac{y_1}{2 \times d_m}\right)^2} \quad (8)$$

where

$y_1$  is the vertical deflection at position 1, in metres;

$d_m$  is the mean diameter of the pipe (see 3.3), in metres;

$e$  is the wall thickness of the pipe, in metres.

## 4 Principle

A cut length of pipe supported horizontally is loaded throughout its length to compress it diametrically to a prescribed level of strain calculated using Equation 8. The force application surfaces are either bearing plates or beam bars.

The pipe is immersed in water at a given temperature for a period of time during which the force remains constant and the vertical deflection is measured at intervals. The long-term specific ring creep stiffness is estimated by extrapolation.

The wet creep factor is then determined from the long-term specific ring creep stiffness and the initial specific ring stiffness of the same test piece. The declared wet creep factor is the average of the results from two test pieces.

NOTE It is assumed that values for the following test parameters will be set by the standard making reference to this International Standard:

- a) the method for measuring the initial specific ring stiffness, i.e. method A or B of ISO 7685:1998 (see 3.4);
- b) the time to which the values are to be extrapolated (see 3.6 and 11.1);
- c) the test temperature (see 5.3 and 10.1);
- d) the length of the test piece (see Clause 6);
- e) if applicable, the conditioning parameters, i.e. temperature, humidity and duration (see Clause 9);
- f) the time limits for maintaining the test piece under load (see 10.6);
- g) the level of strain at which the test is to be conducted.

## 5 Apparatus

### 5.1 Compressive loading machine

The machine shall comprise a system capable of applying a force, without shock, through two parallel force application surfaces conforming to 5.2 so that a horizontally orientated test piece of pipe conforming to Clause 6 and immersed in water can be compressed vertically and maintained under a constant force for the duration of the test in accordance with 10.6.

Equipment shall be available for determining the force applied to within  $\pm 1\%$ .

Ensure that the applied force is not affected by buoyancy effects or friction.

### 5.2 Force application surfaces

The method allows the use of either bearing plates or beam bars for loading the test piece, subject to reporting the choice used. The same loading arrangement (plates, bars, or plate and bar) shall be used for the determination of both initial and long-term stiffness.

#### 5.2.1 General arrangement

The surfaces shall be provided by a pair of plates, conforming to 5.2.2, or a pair of beam bars, conforming to 5.2.3, or a combination of one such plate and one such bar, with their major axes perpendicular to and centred on the direction of application of force  $F$  exerted by the compressive loading machine, as shown in Figure 1. The surfaces to be in contact with the test piece shall be flat, smooth, clean and parallel.



### 5.2.2 Plates

The plate(s) shall have a width of at least 100 mm and a length at least equal to the length of the test piece (see Clause 6). They shall be sufficiently stiff so that they do not visibly bend or otherwise deform during the test.

### 5.2.3 Beam bars

Each beam bar shall be sufficiently stiff that it does not visibly bend or otherwise deform during the test. Each beam bar shall have a length at least equal to the length of the test piece (see Clause 6) and a flat face (see Figure 1) without sharp edges. The width of the flat face shall be 15 mm to 55 mm.

The beam bars shall be so constructed and supported that no other surface of the beam bar structure comes into contact with the test piece during the test.

## 5.3 Water container

Required is a container large enough to accommodate submerged test pieces conforming to Clause 6 whilst they are subject to the compressive force in accordance with 10.5 and containing tap water having a pH of  $7 \pm 2$  and kept at the specified temperature (see 10.1).

The water level shall be maintained sufficiently constant to avoid any significant effect on the value of the vertical force applied to the test piece.

## 5.4 Measuring devices

Required are devices capable of determining:

- a) the necessary dimensions (length, diameters, wall thickness) to an accuracy within that specified in Clause 8, as applicable;
- b) the deflection of the test piece in the vertical direction during the test to an accuracy within  $\pm 1,0$  % of the initial value.

NOTE When selecting the device to measure the change in diameter of the test piece, consideration should be given to the potentially corrosive environment in which the device is to be used.

## 6 Test piece

The test piece shall be a complete ring. The length,  $L$ , in metres, of the test piece shall be as specified in the referring standard, subject to permissible deviations of  $\pm 5$  %. If not specified in the referring standard, the length of the test piece shall be  $(300 \pm 15)$  mm.

The ends shall be smooth, shall be cut perpendicular to the axis of the pipe and may be sealed.

Straight lines shall be drawn on the inside or the outside along the length of the test piece and repeated at  $60^\circ$  intervals around its circumference, to serve as reference lines.

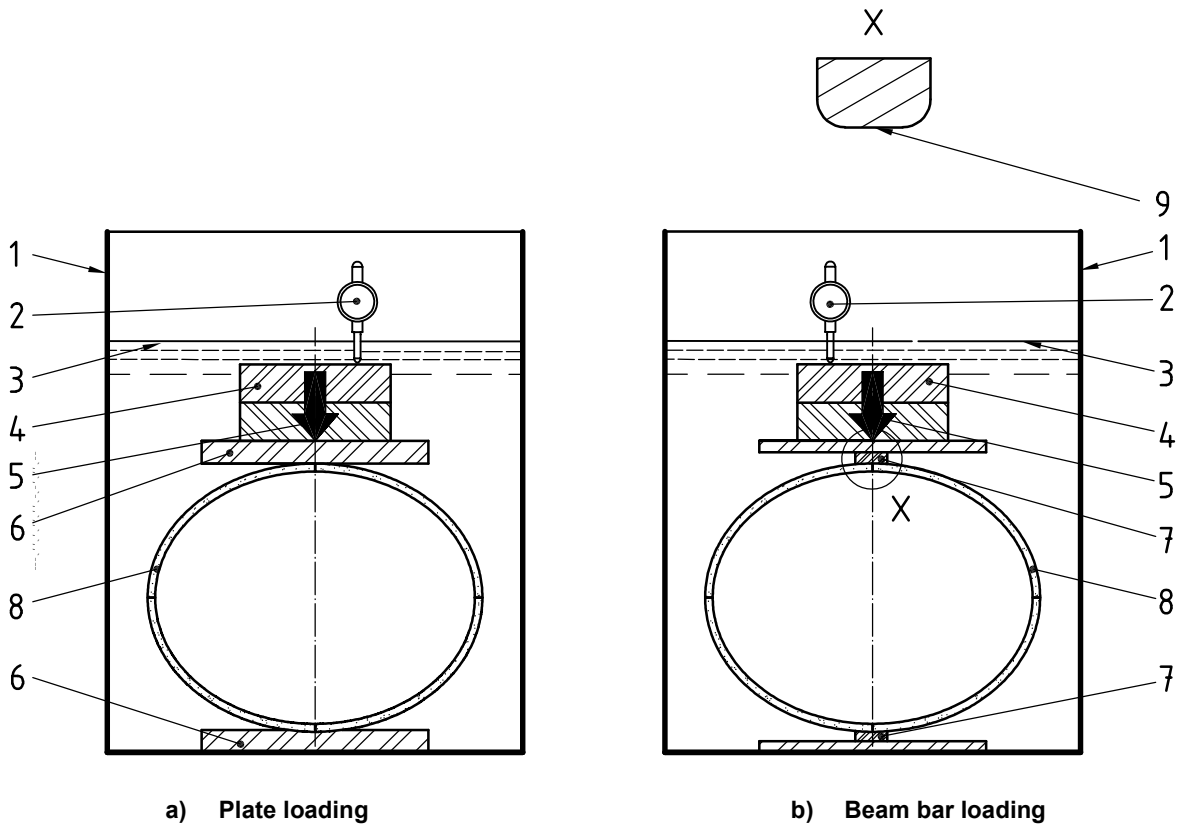

**Key**

- |   |  |   |               |
|---|--|---|---------------|
| 1 | water container                          | 6 | bearing plate |
| 2 | deflection-measuring device              | 7 | beam bar      |
| 3 | water level                              | 8 | test piece    |
| 4 | deadweights                              | 9 | flat face     |
| 5 | direction of compressive force, <i>F</i> |   |               |

**NOTE** It is permissible for the device for measuring deflection, the deadweights, and the bearing plate and beam bar above the test piece to be located above the water level providing the test piece is completely immersed for the duration of the test.

**Figure 1 — Typical test arrangements**

**7 Number of test pieces**

Two test pieces shall be used (see also 11.3).

**8 Determination of the dimensions of the test pieces**

**8.1 Length**

Measure the length of each test piece along each reference line with an accuracy within  $\pm 1,0 \%$  to determine whether or not the test piece conforms to Clause 6. Trim or replace, as applicable, the test piece if it does not conform.

Calculate the mean length, *L*, in metres, of each test piece from the six measured values.

## 8.2 Wall thickness

Measure to within  $\pm 0,2$  mm the wall thickness of each test piece at each end of each reference line.

Calculate the mean wall thickness,  $e$ , in metres, of the 12 measured values.

## 8.3 Mean diameter

Measure to an accuracy within  $\pm 0,5$  mm either of the following:

- a) the internal diameter,  $d_i$ , of the test piece between each diametrically opposed pair of reference lines at their mid-length, e.g. by means of calipers, subsequently calculating the mean internal diameter, in metres, of the six measured values;
- b) the external diameter,  $d_e$ , in metres, of the test piece by means of a circumferential wrap steel tape.

Using either Equation (3) or Equation (4), calculate the mean diameter,  $d_m$  (see 3.3), of the test piece using the value obtained for the mean wall thickness,  $e$ , in 8.2 and either the mean internal diameter or the external diameter.

## 9 Conditioning

If applicable, condition the test pieces in accordance with the referring standard.

## 10 Procedure

**10.1** For each test piece conduct the following procedure at the temperature specified in the referring standard.

**10.2** Determine and record in accordance with ISO 7685 the initial specific ring stiffness,  $S_0$ , of the test piece. Use the measured value of  $S_0$  at a pair of reference lines, to be designated "position 1", to estimate the force required to compress the test piece to the necessary deflection within 3 min to achieve, unless specified otherwise in the referring standard, a calculated strain (see 3.11) between 0,13 % and 0,17 %.

**10.3** Place the test piece in the apparatus in contact with the upper and lower plate or the beam bars, with the pair of diametrically opposed reference lines designated "position 1", in accordance with 10.2, vertically aligned. Ensure that the contact between the test piece and each bearing plate or beam bar is as uniform as possible and the plates and/or beam bars are not tilted laterally. Place the apparatus in the water container.

**10.4** Fill the container with water so that the test piece is fully immersed.

**10.5** When the test piece is fully immersed in the water and taking account, as necessary, of the mass of the upper plate or beam bar, apply the vertical compressive force,  $F$ , estimated in accordance with 10.2 so that the corresponding vertical deflection is reached within 3 min and record the actual force applied and deflection achieved.

**10.6** Hold the force constant throughout the duration of the test. Commencing at not more than 1 h after loading and continuing for more than 10 000 h, measure and record, to within 2 % of the initial value, the deflection of the test piece at approximately equal intervals of  $\lg(\text{time})$  after loading. The intervals shall be such that ten approximately equally spaced readings are taken for each decade of  $\lg(\text{time in h})$ .

NOTE Table A.1 in Annex A gives values of equal  $\lg(\text{time in h})$  increments which may be useful to the operator.

## 11 Calculation

### 11.1 Extrapolation of the deflection data

If required by the referring standard, use the data obtained in accordance with 10.6, and plot  $\lg(\text{deflection})$  as a function of  $\lg(\text{time})$ .

From the measured deflections and corresponding time intervals between 1 h and over 10 000 h, calculate for each test piece the specific ring stiffness under wet conditions, for position 1, using Equation (9):

$$S_{x, 1, \text{creep, wet}} = \frac{f \times F}{L \times y_{x, 1, \text{wet}}} \quad (9)$$

where

$S_{x, 1, \text{creep, wet}}$  is the specific ring creep stiffness, after  $x$  years, in newtons per square metre, for position 1 under wet conditions;

$f$  is the deflection coefficient, which has the value given by Equation (7):

$$f = [1860 + (2\,500 \times y_1 / d_m)] \times 10^{-5} \quad (7)$$

$y_{x, 1, \text{wet}}$  is the deflection, in metres, produced by the constant force after  $x$  years at position 1 under wet conditions, determined in accordance with 10.6;

$L$  is the mean length of the test piece, in metres;

$F$  is the force, in newtons.

For each test piece, analyse the stiffness versus time data in accordance with method B of ISO 10928:1997.

### 11.2 Calculation of the long-term specific ring creep stiffness under wet conditions for position 1

Using the results of the analysis in 11.1, calculate and report the long-term specific ring creep stiffness under wet conditions for position 1,  $S_{x, 1, \text{creep, wet}}$ , for  $x$  years (see 3.6) as specified by the referring standard.

### 11.3 Calculation of the wet creep factor

For each test piece, calculate the wet creep factor,  $\alpha_{x, \text{creep, wet}}$ , using Equation (6).

When determined in accordance with this standard, the declared wet creep factor shall be the average of the values for  $\alpha_{x, \text{creep, wet}}$  obtained from the two test pieces.

## 12 Test report

The test report shall include the following information:

- a) a reference to this International Standard and the referring standard;
- b) full identification of the pipe tested;
- c) the number of test pieces;
- d) the dimensions of each test piece;

- e) the positions in the pipe from which the test pieces were obtained;
- f) the initial specific ring stiffness,  $S_0$ , and the initial specific ring stiffness at position 1,  $S_{0, 1}$ , of each test piece;
- g) the vertical compressive force,  $F$ , applied, the initial deflection achieved and the initial strain, both at 3 min for each test piece;
- h) if applicable, details of any conditioning (see Clause 9);
- i) for each test piece, whether the cut ends were sealed (see Clause 6);
- j) equipment details, including whether beam bars and/or plates were used and, if beam bars were used, the width of the flat face;
- k) the temperature and pH of the test water;
- l) if required by the referring standard, for each test piece the plot of measured deflection versus time;
- m) for each test piece, the calculated long-term specific ring creep stiffness,  $S_{x, 1, \text{creep, wet}}$  at position 1;
- n) for each test piece, the wet creep factor,  $\alpha_{x, \text{creep, wet}}$ ;
- o) the calculated declared wet creep factor (see 11.3);
- p) a description of the test pieces after testing;
- q) any factors which may have affected the results, such as any incidents or any operating details not specified in this International Standard;
- r) for each test piece, the dates and duration of the test period, in hours.

## Annex A (informative)

### Equal increments of $\lg(\text{time in h})$

Table A.1 presents intervals of time, in minutes, hours or days, which correspond to successive equal increments of 0,1 in  $\lg(\text{time in h})$ . This information is provided for assistance in scheduling measurements of the deflection of the test pieces.

**Table A.1 — Times comprising equal increments of  $\lg(\text{time in h})$**

lg(time in h)	Time			lg(time in h)	Time		
	min	h	days		min	h	days
0,0	60	1	0,042	3,0	60 000	1 000	41,7
0,1	76	1,3	0,052	3,1	75 536	1 259	52,5
0,2	95	1,6	0,066	3,2	95 094	1 585	66,0
0,3	120	2,0	0,083	3,3	119 716	1 995	83,1
0,4	151	2,5	0,105	3,4	150 713	2 512	104,7
0,5	190	3,2	0,132	3,5	189 737	3 162	131,8
0,6	239	4,0	0,166	3,6	238 864	3 981	165,9
0,7	301	5,0	0,209	3,7	300 712	5 012	208,8
0,8	379	6,3	0,263	3,8	378 574	6 310	262,9
0,9	477	7,9	0,331	3,9	476 597	7 943	331,0
1,0	600	10	0,42	4,0	600 000	10 000	416,7
1,1	755	13	0,52	4,1	755 355	12 589	524,6
1,2	951	16	0,66	4,2	950 936	15 849	660,4
1,3	1 197	20	0,83	4,3	1 197 157	19 953	831,4
1,4	1 507	25	1,05	4,4	1 507 132	25 119	1 046,6
1,5	1 897	32	1,32	4,5	1 897 367	31 623	1 317,6
1,6	2 389	40	1,66	4,6	2 388 643	39 811	1 658,8
1,7	3 007	50	2,09	4,7	3 007 123	50 119	2 088,3
1,8	3 786	63	2,63	4,8	3 785 744	63 096	2 629,0
1,9	4 766	79	3,31	4,9	4 765 969	79 433	3 309,7
2,0	6 000	100	4,17				
2,1	7 554	126	5,25				
2,2	9 509	158	6,60				
2,3	11 972	200	8,31				
2,4	15 071	251	10,47				
2,5	18 974	316	13,18				
2,6	23 886	398	16,59				
2,7	30 071	501	20,88				
2,8	37 857	631	26,29				
2,9	47 660	794	33,10				



.....

---

---

**ICS 23.040.20**

Price based on 10 pages