

INTERNATIONAL STANDARD

ISO 10434

Second edition
2004-07-15

Bolted bonnet steel gate valves for the petroleum, petrochemical and allied industries

*Robinets-vannes en acier à chapeau boulonné pour les industries du
pétrole, de la pétrochimie et les industries connexes*



Reference number
ISO 10434:2004(E)

© ISO 2004

PDF disclaimer

This PDF file may contain embedded typefaces. In accordance with Adobe's licensing policy, this file may be printed or viewed but shall not be edited unless the typefaces which are embedded are licensed to and installed on the computer performing the editing. In downloading this file, parties accept therein the responsibility of not infringing Adobe's licensing policy. The ISO Central Secretariat accepts no liability in this area.

Adobe is a trademark of Adobe Systems Incorporated.

Details of the software products used to create this PDF file can be found in the General Info relative to the file; the PDF-creation parameters were optimized for printing. Every care has been taken to ensure that the file is suitable for use by ISO member bodies. In the unlikely event that a problem relating to it is found, please inform the Central Secretariat at the address given below.

© ISO 2004

All rights reserved. Unless otherwise specified, no part of this publication may be reproduced or utilized in any form or by any means, electronic or mechanical, including photocopying and microfilm, without permission in writing from either ISO at the address below or ISO's member body in the country of the requester.

ISO copyright office
Case postale 56 • CH-1211 Geneva 20
Tel. + 41 22 749 01 11
Fax + 41 22 749 09 47
E-mail copyright@iso.org
Web www.iso.org

Published in Switzerland

Contents

Page

Foreword	iv
Introduction	v
1 Scope	1
2 Normative references	1
3 Terms and definitions	3
4 Pressure/temperature ratings	3
5 Design	3
6 Materials	18
7 Testing, inspection and examination	21
8 Marking	24
9 Preparation for despatch	25
Annex A (informative) Information to be specified by the purchaser	27
Annex B (informative) Identification of valve terms	28
Bibliography	30

Foreword

ISO (the International Organization for Standardization) is a worldwide federation of national standards bodies (ISO member bodies). The work of preparing International Standards is normally carried out through ISO technical committees. Each member body interested in a subject for which a technical committee has been established has the right to be represented on that committee. International organizations, governmental and non-governmental, in liaison with ISO, also take part in the work. ISO collaborates closely with the International Electrotechnical Commission (IEC) on all matters of electrotechnical standardization.

International Standards are drafted in accordance with the rules given in the ISO/IEC Directives, Part 2.

The main task of technical committees is to prepare International Standards. Draft International Standards adopted by the technical committees are circulated to the member bodies for voting. Publication as an International Standard requires approval by at least 75 % of the member bodies casting a vote.

Attention is drawn to the possibility that some of the elements of this document may be the subject of patent rights. ISO shall not be held responsible for identifying any or all such patent rights.

ISO 10434 was prepared by Technical Committee ISO/TC 153, *Valves*, Subcommittee SC 1, *Design, manufacture, marking and testing* in collaboration with Technical Committee ISO/TC 67, *Materials, equipment and offshore structures for petroleum, petrochemical and natural gas industries*, Subcommittee SC 6, *Processing equipment and systems*.

This second edition cancels and replaces the first edition (ISO 10434:1998), which has been technically revised.

Introduction

The purpose of this International Standard is to establish the basic requirements and practices for flanged and butt-welding end steel gate valves of bolted bonnet construction that parallel those given in American Petroleum Institute API Standard 600, eleventh edition, 2001 (ISO 10434:1998). It is not the purpose of this International Standard to replace ISO 6002 or any other International Standard that is not identified with petroleum refinery, petrochemical or natural gas industry applications.

Bolted bonnet steel gate valves for the petroleum, petrochemical and allied industries

1 Scope

This International Standard specifies the requirements for a heavy-duty series of bolted bonnet steel gate valves for petroleum refinery and related applications where corrosion, erosion and other service conditions would indicate a need for full port openings, heavy wall sections and large stem diameters.

This International Standard sets forth the requirements for the following gate valve features:

- bolted bonnet;
- outside screw and yoke;
- rising stems;
- non-rising handwheels;
- single or double gate;
- wedge or parallel seating;
- metallic seating surfaces;
- flanged or butt-welding ends.

It covers valves of the nominal sizes DN:

- 25; 32; 40; 50; 65; 80; 100; 150; 200; 250; 300; 350; 400; 450; 500; 600;

corresponding to nominal pipe sizes NPS:

- 1; 1 1/4; 1 1/2; 2; 2 1/2; 3; 4; 6; 8; 10; 12; 14; 16; 18; 20; 24;

and applies for pressure Class designations:

- 150; 300; 600; 900; 1500; 2500.

2 Normative references

The following referenced documents are indispensable for the application of this document. For dated references, only the edition cited applies. For undated references, the latest edition of the referenced document (including any amendments) applies.

ISO 7-1, *Pipe threads where pressure-tight joints are made on the threads — Part 1: Dimensions, tolerances and designation*

ISO 10434:2004(E)

ISO 5208, *Industrial valves — Pressure testing of valves*

ISO 5209, *General purpose industrial valves — Marking*

ISO 5210, *Industrial valves — Multi-turn valve actuator attachments*

ISO 5752, *Metal valves for use in flanged pipe systems — Face-to-face and centre-to-face dimensions*

ISO 9606-1, *Approval testing of welders — Fusion welding — Part 1: Steels*

ISO 15607, *Specification and qualification of welding procedures for metallic materials — Part 1: General rules*

ISO 15609-1, *Specification and qualification of welding procedures for metallic materials — Welding procedure specification — Part 1: Arc welding¹⁾*

ISO 15610, *Specification and qualification of welding procedures for metallic materials — Qualification based on tested welding consumables*

ISO 15614-1, *Specification and qualification of welding procedures for metallic materials — Welding procedure test — Part 1: Arc and gas welding of steels and arc welding of nickel and nickel alloys*

ISO 15614-2, *Specification and qualification of welding procedures for metallic materials — Welding procedure test — Part 2: Arc welding of aluminium and its alloys²⁾*

ASME B1.1, *Unified inch screw threads (UN and UNR thread form)*

ASME B1.5, *Acme screw threads*

ASME B1.8, *Stub acme screw threads*

ASME B1.12, *Class 5 interference-fit thread*

ASME B1.20.1, *Pipe threads, general purpose (inch)*

ASME B16.5, *Pipe flanges and flanged fittings*

ASME B16.10, *Face-to face and end-to-end dimensions of valves*

ASME B16.11, *Forged fittings, socket-welding and threaded*

ASME B16.34:1996, *Valves — Flanged, threaded and welding end*

ASME B18.2.2, *Square and hex nuts — Inch series*

ASME BPVC-IX, *BPVC Section IX — Welding and brazing qualifications*

ASTM A193, *Standard specification for alloy-steel and stainless steel bolting materials for high temperature service*

ASTM A194, *Standard specification for carbon and alloy steel nuts for bolts for high pressure or high temperature service, or both*

1) To be published. (Replaces ISO 9956-2:1995)

2) To be published. (Replaces ISO 9956-4:1995)

ASTM A307, *Standard specification for carbon steel bolts and studs, 60 000 PSI tensile strength*

MSS-SP-55, *Quality standard for steel castings for valves, flanges and fittings and other piping components — Visual method for evaluation of surface irregularities*

3 Terms and definitions

For the purposes of this document, the definitions for pressure designation, Class, and nominal valve size NPS given in ASME B16.34, and the following apply.

3.1

DN

alphanumeric designation of size for components of a pipework system, which is used for reference purposes, comprising the letters DN followed by a dimensionless whole number which is indirectly related to the physical size, in millimetres, of the bore or outside diameter of the end connections

[ISO 6708:1995, definition 2.1]

4 Pressure/temperature ratings

4.1 The pressure/temperature ratings applicable to valves specified in this International Standard shall be in accordance with those specified in the tables of ASME B16.34 for Standard Class for the applicable material specification and the applicable Class. Restrictions of temperature and pressure, for example, those imposed by special soft seals or special trim materials, shall be marked on the valve identification plate, see 8.4.

4.2 The temperature for a corresponding pressure rating is the maximum temperature of the pressure-containing shell of the valve. In general, this temperature is the same as that of the contained fluid. The use of a pressure rating corresponding to a temperature other than that of the contained fluid is the responsibility of the user.

4.3 For temperatures below the lowest temperature listed in the pressure/temperature tables (see 4.1), the service pressure shall be no greater than the pressure for the lowest listed temperature. The use of valves at lower temperatures is the responsibility of the user. Consideration should be given to the loss of ductility and impact strength of many materials at low temperature.

4.4 Double seated valves, in some design configurations, may be capable of trapping liquid in the centre cavity of the valve when in the closed position. If subjected to an increase in temperature, an excessive build-up of pressure may occur leading to a pressure boundary failure. Where such condition is possible it is the responsibility of the user to provide, or require to be provided, means in design, installation or operating procedure to assure that the pressure in the valve does not exceed that allowed by this International Standard for the resultant temperature.

5 Design

5.1 Body wall thickness

5.1.1 A valve body schematic is shown as Figure 1. The minimum body wall thickness, t_m , at the time of manufacture shall be as given in Table 1, except as indicated in 5.1.2 for butt-welding valve ends. Additional metal thickness needed for assembly stresses, stress concentrations, and shapes other than circular shall be determined by individual manufacturers, since these factors vary widely.

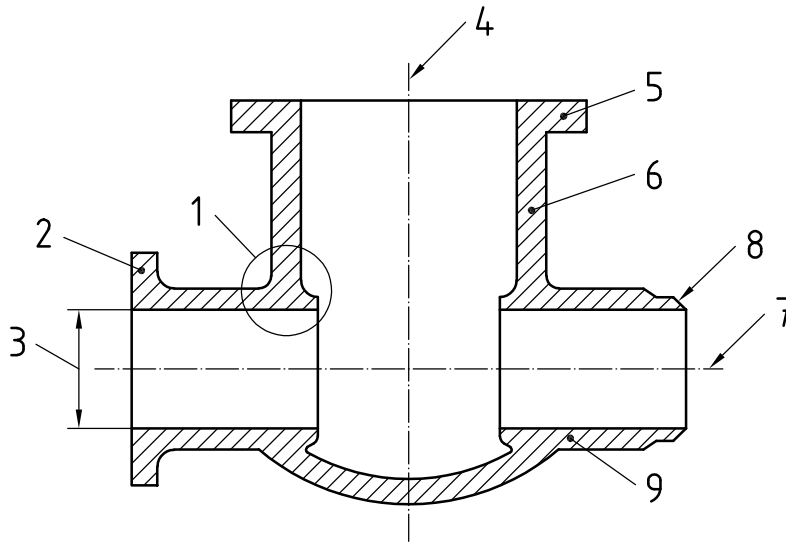

Key

- | | | | |
|---|------------------------------------|---|------------------|
| 1 | junction of body run and body neck | 6 | body neck |
| 2 | body end flange | 7 | axis of body run |
| 3 | body end port inside diameter | 8 | butt-welding end |
| 4 | axis of body neck | 9 | body run |
| 5 | body/bonnet flange | | |

Figure 1 — Identification of terms

Table 1 — Minimum wall thickness for body and bonnet

Nominal size DN	Class designation						Nominal size NPS
	150	300	600	900	1500	2500	
	Minimum wall thickness t_m mm						
25	6,4	6,4	7,9	12,7	12,7	15,0	1
32	6,4	6,4	8,6	14,2	14,2	17,5	1 1/4
40	6,4	7,9	9,4	15,0	15,0	19,1	1 1/2
50	8,6	9,7	11,2	19,1	19,1	22,4	2
65	9,7	11,2	11,9	22,4	22,4	25,4	2 1/2
80	10,4	11,9	12,7	19,1	23,9	30,2	3
100	11,2	12,7	16,0	21,3	28,7	35,8	4
150	11,9	16,0	19,1	26,2	38,1	48,5	6
200	12,7	17,5	25,4	31,8	47,8	62,0	8
250	14,2	19,1	28,7	36,6	57,2	67,6	10
300	16,0	20,6	31,8	42,2	66,8	86,6	12
350	16,8	22,4	35,1	46,0	69,9	—	14
400	17,5	23,9	38,1	52,3	79,5	—	16
450	18,3	25,4	41,4	57,2	88,9	—	18
500	19,1	26,9	44,5	63,5	98,6	—	20
600	20,6	30,2	50,8	73,2	114,3	—	24

5.1.2 The weld end preparation in butt-welding end valves (see 5.3.2) shall not reduce the body wall thickness to less than the values specified in 5.1.1 within a region closer than t_m to the outside surface of the body neck, measured along the run direction. The transition to the weld preparation shall be gradual and the section shall be essentially circular through the entire length of the transition. Sharp discontinuities or abrupt changes in section in areas that infringe into the transition shall be avoided, except that test collars or bands, either welded or integral, are allowed. In no case shall the thickness be less than $0,77 t_m$ at a distance of $1,33 t_m$ from the weld end.

5.2 Bonnet wall thickness

The minimum bonnet wall thickness at the time of manufacture, except for the neck extension that contains the packing, shall be t_m as given in Table 1. For the neck extension, the local minimum wall thickness shall be based on the local diameter, e.g. the inside diameter of the stem bore or packing box bore, and shall be in accordance with Table 2.

5.3 Body dimensions

5.3.1 Flanged ends

5.3.1.1 Body end flanges shall comply with the dimensional requirements of ASME B16.5. Unless otherwise specified by the purchaser, gasket contact facing finish of the end flanges shall be in accordance with ASME B16.5. Raised face end flanges shall be provided unless ring-joint or flat face flanges are specified by the purchaser.

Table 2 — Minimum wall thickness for bonnet neck extension

Bonnet neck extension inside diameter mm	Class designation					
	150	300	600	900	1500	2500
	Minimum wall thickness ^a mm					
15	2,8	3,0	3,6	4,2	5,3	7,6
16	2,8	3,1	3,6	4,4	5,6	7,9
17	2,8	3,2	3,7	4,5	5,8	8,2
18	2,9	3,5	3,9	4,7	5,9	8,5
19	3,0	3,8	4,1	5,1	6,1	8,9
20	3,3	4,0	4,2	5,2	6,3	9,2
25	4,0	4,8	4,8	6,3	7,1	11,0
30	4,6	4,8	4,8	6,5	8,2	13,1
35	4,8	4,8	5,1	7,1	9,7	14,6
40	4,9	5,0	5,7	7,5	10,2	16,4
50	5,5	6,2	6,3	7,9	11,6	19,8
60	5,6	6,4	6,8	8,9	13,4	23,2
70	5,6	6,9	7,4	9,9	15,8	26,5
80	5,8	7,2	8,1	11,0	17,4	30,1
90	6,4	7,4	8,8	12,0	19,1	33,2
100	6,4	7,7	9,5	12,8	20,8	36,7
110	6,4	8,1	10,3	14,1	22,9	40,1
120	6,6	8,6	10,9	14,9	24,8	43,5
130	7,1	8,8	11,3	16,2	26,5	46,9
140	7,1	9,2	12,0	17,3	28,3	50,2

^a See 5.2.

5.3.1.2 Face-to-face dimensions for flanged end valves, Class 150, 300, and 600, shall be in accordance with ASME B16.10 or ISO 5752, Basic Series 3, 4 and 5, except that the applicable tolerance shall be in accordance with the tolerances specified in Table 4. For Class > 600, the face-to-face dimensions shall be the same as the end-to-end dimensions given in Table 4.

5.3.1.3 Body end flanges and bonnet flanges shall be cast or forged integral with the body. However, when specified by the purchaser, forged flanges may be attached by welding by a qualified welding operator using a qualified welding procedure. It is required that when these flanges are attached by welding, a butt-welded type joint shall be used. Heat treatment to ensure that the welded material is suitable for the full range of service conditions shall be performed in accordance with the material specification.

5.3.2 Butt-welding ends

5.3.2.1 Butt-welding ends shall be in accordance with Figure 2 and Table 3 unless otherwise specified by the purchaser.

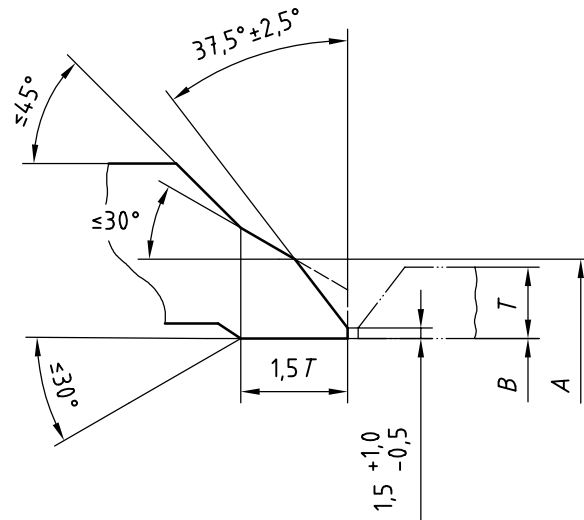

a) Welding end for connection to pipe of wall thickness $T \leq 22$ mm

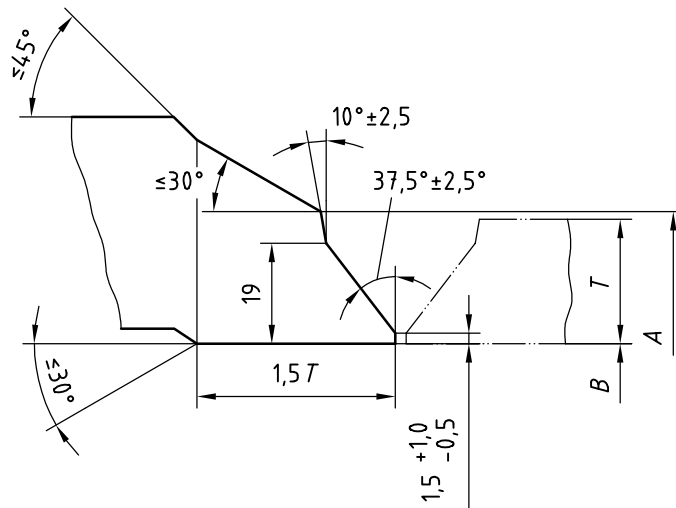

b) Welding end for connection to pipe of wall thickness $T > 22$ mm

Key

- A nominal outside diameter of welding end
- B nominal inside diameter of pipe
- T nominal wall thickness of pipe

Figure 2 — Welding ends

Table 3 — Butt-welding end diameters

Nominal size, DN	25	32	40	50	65	80	100	150	200	250	300	350	400	450	500	600
Nominal size, NPS	1	1 1/4	1 1/2	2	2 1/2	3	4	6	8	10	12	14	16	18	20	24
A mm diameter	35	44	50	62	78	91	117	172	223	278	329	362	413	464	516	619
A mm tolerance	+ 2,5 / - 1,0							+ 4 / - 1								
B mm tolerance	+ 1 / - 1						+ 2 / - 2					+ 3 / - 2				

The inside and outside surfaces of valve welding ends are machine finished overall. The contour within the envelope is at the option of the manufacturer unless specifically ordered otherwise.

Intersections should be slightly rounded.

Valves with minimum wall thickness equal to 3 mm or less may have ends cut square or slightly chamfered.

For nominal outside diameters and wall thickness of standard steel pipe, see ISO 4200.

5.3.2.2 End-to-end dimensions for butt-welding end valves shall be in accordance with Table 4, unless otherwise specified by the purchaser.

Table 4 — End-to-end dimensions for butt-welding end valves

Nominal Size DN	Class designation						Nominal Size NPS
	150	300	600	900	1500	2500	
	End-to-end dimensions mm						
25	127	165	216	254	254	308	1
32	140	178	229	279	279	349	1 1/4
40	165	190	241	305	305	384	1 1/2
50	216	216	292	368	368	451	2
65	241	241	330	419	419	508	2 1/2
80	283	283	356	381	470	578	3
100	305	305	432	457	546	673	4
150	403	403	559	610	705	914	6
200	419	419	660	737	832	1 022	8
250	457	457	787	838	991	1 270	10
300	502	502	838	965	1 130	1 422	12
350	572	762	889	1 029	1 257	—	14
400	610	838	991	1 130	1 384	—	16
450	660	914	1 092	1 219	1 537	—	18
500	711	991	1 194	1 321	1 664	—	20
600	813	1 143	1 397	1 549	1 943	—	24

Tolerances applicable to the dimensions:

— For DN ≤ 250: ± 2 mm;

— For DN > 250: ± 3 mm.

5.3.3 Body seats

5.3.3.1 The inside diameter of the body seat, except for assembly drive lugs on threaded seat rings, shall not be less than the applicable value specified in Table 5.

5.3.3.2 Integral body seats are permitted in austenitic stainless steel valves. When an austenitic stainless steel or a hardfacing material is used for the body seat, this material may be weld-deposited directly on the valve body. Otherwise, valve bodies shall have separate shoulder or bottom seated seat rings that are either threaded or welded in place, except that for $DN \leq 50$, rolled or pressed-in seat rings may be used.

5.3.3.3 Body seating surfaces shall not have sharp corners at either the inner or outer seat circumference.

5.3.3.4 Sealing compounds or greases shall not be used when assembling seat rings; however, a light lubricant having a viscosity no greater than kerosene may be used to prevent galling of mating threaded surfaces.

Table 5 — Body seat inside diameter

Nominal Size DN	Class designation						Nominal Size NPS
	150	300	600	900	1500	2500	
	Minimum port diameter mm						
25	25	25	25	22	22	19	1
32	31	31	31	28	28	25	1 1/4
40	38	38	38	34	34	28	1 1/2
50	50	50	50	47	47	38	2
65	63	63	63	57	57	47	2 1/2
80	76	76	76	72	69	57	3
100	100	100	100	98	92	72	4
150	150	150	150	146	136	111	6
200	200	200	199	190	177	146	8
250	250	250	247	238	222	184	10
300	300	300	298	282	263	218	12
350	336	336	326	311	288	241	14
400	387	387	374	355	330	276	16
450	431	431	419	400	371	311	18
500	482	482	463	444	415	342	20
600	584	584	558	533	498	412	24

5.4 Bonnet dimensions

5.4.1 The bonnet stem hole shall be designed to have proper clearance for stem guiding and for the prevention of packing extrusion.

5.4.2 The bonnet shall include a conical stem backseat in one of the following forms:

- a bushing positively secured against coming loose, i.e. not relying on friction;
- an integral surface in the case of an austenitic stainless steel valve;
- an austenitic stainless steel or hardfaced weld deposit that is a minimum of 1,6 mm thick.

5.4.3 The restrictions of 5.12.3 on openings also apply to the bonnet.

5.4.4 Bonnets shall be one-piece castings or forgings subject to the same exceptions and requirements as specified in 5.3.1.3.

5.4.5 The gland bolting shall not be anchored to the bonnet or yoke through a fillet welded attachment or stud welded pins. The gland bolt design shall be such that during repacking the gland bolts are positively retained.

5.5 Bonnet-to-body joint

5.5.1 The bonnet-to-body joint shall be a flange and gasket type.

5.5.2 For Class 150 valves, the bonnet-to-body joint shall be one of the following types illustrated in ASME B16.5:

- flat face;
- raised face;
- tongue and groove;
- spigot and recess;
- ring joint.

5.5.3 For valves having pressure class designation greater than Class 150, the bonnet-to-body joint shall be as in 5.5.2, except that the flat face joint is not permitted.

5.5.4 The bonnet flange gasket shall be suitable for the temperature range – 29 °C to 538 °C and be one of the following:

- solid metal, corrugated or flat;
- filled metal jacketed, corrugated or flat;
- metal ring joint;
- spiral-wound metal gasket with filler and a centring/compression ring;
- spiral-wound metal gasket with filler, to be used only in a body-to-bonnet joint design that provides gasket compression control.

For Class 150, the following may also be used:

- flexible graphite sheet, reinforced with a stainless steel tanged or corrugated insert.

5.5.5 Except for Class 150 valves and valves in sizes DN 65 and smaller, bonnet-to-body flanges shall be circular.

5.5.6 Bonnet and body flange nut bearing surfaces shall be parallel to the flange face within $\pm 1^\circ$. Spot facing or backfacing required to meet the parallelism requirement shall be in accordance with ASME B16.5.

5.5.7 The bonnet-to-body joint shall be secured by a minimum of four through type stud bolts. The minimum stud bolt size for each valve size shall be as follows:

- either M10 or 3/8 when $25 \leq DN \leq 65$;

- either M12 or ½ when $80 \leq DN \leq 200$;
- either M16 or 5/8 when $250 \leq DN$.

5.5.8 The valve bonnet bolting cross-sectional area shall, as a minimum, meet the following requirement:

$$P_c \frac{A_g}{A_b} \leq 65,26 S_b \leq 9\,000$$

where

P_c is the pressure class designation number, e.g. 150;

S_b is the allowable bolt stress at 38 °C, expressed in megapascals: when its value is > 138 MPa, use 138 MPa;

A_g is the area bounded by the effective outside periphery of the gasket — except that, in the case of a ring joint, the bounded area is defined by the pitch diameter of the ring — expressed in square millimetres;

A_b is the total effective bolt tensile stress area, expressed in square millimetres.

5.5.9 At assembly, all gasket contact surfaces shall be free of heavy oils, grease and sealing compounds. A light coating of a lubricant, no heavier than kerosene, may be applied if needed to assist in proper gasket assembly.

5.6 Gate

5.6.1 Gate configurations are categorized as illustrated in Annex B.

5.6.2 A one-piece wedge gate — as either a solid or flexible wedge design — shall be furnished, unless otherwise specified.

5.6.3 A two-piece split wedge gate or parallel seat double disc gate may be furnished when specified. A split wedge gate consists of two independent seating parts that conform to the body seats when closed. A double disc gate has a spreading mechanism that forces the two parallel discs to the body seats when closed.

5.6.4 Except for a double disc gate, in the open position, the gate shall completely clear the valve seat openings.

5.6.5 Gate and gate guides shall be designed so that all parts can function properly independent of installed valve orientation.

5.6.6 Guides shall be provided in the gate and shell and these guides shall be designed so as to minimize seat wear and maintain gate-to-stem alignment in all valve orientations. Gate-to-shell design shall consider wear that may be caused by corrosion, erosion and abrasion.

5.6.7 Gate seating surfaces shall be integral or faced with weld metal. Unless specified, hardfaced seating surfaces are not required. Finished thickness of any facing material shall be not less than 1,6 mm.

5.6.8 Wedge gates shall be designed to account for seat wear. The dimensions that fix the position of the gate seats relative to the body seats shall be such that the gate, starting from the time of manufacture, can, as a result of seat wear, move into the seats by a distance, h , defined as wear travel. Wear travel is in a direction that is parallel with the valve stem. The required minimum wear travel varies with valve size in accordance with Table 6.

Table 6 — Minimum wear travel

Valve size range DN	Wear travel, h mm
$25 \leq DN \leq 50$	2,3
$65 \leq DN \leq 150$	3,3
$200 \leq DN \leq 300$	6,4
$350 \leq DN \leq 450$	9,7
$500 \leq DN \leq 600$	12,7

5.7 Yoke

5.7.1 The yoke may be either an integral part of the bonnet or a separate part. The yoke shall retain the stem nut which links the handwheel to the stem.

5.7.2 Yokes shall be designed so that the stem nut can be removed when the valve is under pressure without removing the bonnet from the valve body.

5.7.3 Yokes that are separate shall have the yoke-to-bonnet mating surfaces machined.

5.7.4 The yoke-to-stem nut bearing surfaces shall be machined flat and parallel. A lubricating fitting shall be provided for the bearing surfaces.

5.8 Stem and stem nut

5.8.1 The minimum stem diameter, d_s , shall be as given in Table 7. The minimum stem diameter applies to the stem in the packing area and to the major diameter of the trapezoidal stem thread. However, the major diameter of the stem thread may be reduced, at the manufacturer's option, by no more than 1,6 mm. The stem surface area in contact with the packing shall have a surface finish, Ra of 0,80 μm or smoother.

Table 7 — Minimum stem diameter

Nominal size DN	Class designation						Nominal size NPS
	150	300	600	900	1500	2500	
	Minimum stem diameter d_s mm						
25	15,59	15,59	15,59	18,77	18,77	18,77	1
32	15,59	15,59	15,59	18,77	18,77	18,77	1 1/4
40	17,17	18,77	18,77	21,87	21,87	21,87	1 1/2
50	18,17	18,17	18,77	25,04	25,04	25,04	2
65	18,77	18,77	21,87	28,22	28,22	28,22	2 1/2
80	21,87	21,87	25,04	28,22	31,69	31,39	3
100	25,04	25,04	28,22	31,39	34,47	34,47	4
150	28,22	31,39	37,62	40,77	43,84	46,94	6
200	31,39	34,47	40,77	46,94	53,24	59,54	8
250	34,47	37,62	46,94	53,24	62,74	72,24	10
300	37,62	40,77	50,29	56,44	69,14	81,84	12
350	40,77	43,84	56,44	59,54	75,44	—	14
400	43,84	46,94	59,54	62,74	75,44	—	16
450	46,94	50,14	62,74	69,14	—	—	18
500	50,14	53,24	69,14	75,44	—	—	20
600	56,44	62,74	75,44	—	—	—	24

5.8.2 Stems shall have a gate attachment means at one end and an external trapezoidal style thread form at the other. Stem nuts shall be used for handwheel attachment and to drive the operating stem thread.

5.8.3 The stem-to-stem nut threads shall be of trapezoidal form as specified in ASME B1.5 or ASME B1.8, with nominal dimensional variations allowed. Stem threads shall be left-handed so that a direct operated handwheel rotated in a clockwise direction closes the valve.

5.8.4 The stem shall be one-piece wrought material. Welded fabrication is not permitted.

5.8.5 The stem end that connects to a gate shall be in the form of a "T", except that for a double disc gate, the end connection may be threaded.

5.8.6 The stem connection shall be designed to prevent the stem from turning or from becoming disengaged from the gate while the valve is in service.

5.8.7 The stem design shall be such that the strength of the stem-to-gate connection and the part of the stem within the valve pressure boundary shall, under axial load, exceed the strength of the stem at the root of the operating thread.

5.8.8 The one-piece stem shall include a conical or spherical raised surface that seats against the bonnet backseat when the gate is at its full open position.

A stem-bonnet backseat is a requirement of this International Standard and, as such, is not meant to imply a manufacturer's recommendation of its use for the purpose of adding or replacing packing while the valve is under pressure.

5.8.9 The stem nut design shall allow for the removal of the handwheel while keeping the stem (and disc) in a fixed position.

5.8.10 The stem nut shall be attached to the handwheel through a hexagonal interface, a round interface having a keyway or any other means of equivalent strength.

5.8.11 When the stem nut is retained in the yoke by means of a threaded bushing, the bushing shall be secured in place using either a lock weld or a positive mechanical lock. Locking by simple metal upsetting such as peening or staking is not permitted.

5.8.12 The closed-position stem thread projection beyond the stem nut on a new valve shall be a distance having a minimum equal to the valve wear travel and a maximum of five times the wear travel for valves DN 150 or smaller and three times the wear travel for valves larger than DN 150.

5.8.13 Valves DN 150 or larger with Class 600 or greater, shall be furnished with stem nuts having ball or roller bearings.

5.9 Packing and packing box

5.9.1 The packing may be either square or rectangular in cross-section. The nominal radial width of the packing, *w*, shall be in accordance with Table 8.

Table 8 — Nominal radial width of packing

Nominal stem diameter <i>d</i> mm	Nominal radial width of the packing <i>w</i> mm	Packing box clearance factor <i>y</i> mm
15 < <i>d</i> ≤ 27	6,4	0,4
27 < <i>d</i> ≤ 37	7,9	0,4
37 < <i>d</i> ≤ 49	9,5	0,4
49 < <i>d</i> ≤ 56	11,1	0,8
56 < <i>d</i> ≤ 74	12,7	0,8
74 < <i>d</i>	14,3	0,8

5.9.2 The nominal depth of the packing box shall accommodate a minimum of five uncompressed rings of packing. Unless otherwise specified, the packing box surface area in contact with the packing material shall have a surface finish, *Ra* of 3,2 µm or smoother.

5.9.3 The nominal bore (inside diameter) of the packing box shall be equal to the nominal stem diameter plus twice the nominal packing width plus a clearance factor, *y*, i.e. $d + 2w + y$. See Table 8.

5.9.4 A gland and a separate gland flange shall be provided for packing compression. The gland flange shall have two holes to receive the gland bolting. Slots for gland flange bolts shall not be used. The gland and gland flange shall be self-aligning. The gland shall have a shoulder at its outer edge so as to prevent complete entry of the gland into the packing box.

5.9.5 A lantern ring shall be provided only if so specified by the purchaser. Holes shall be located 180° apart on each end for its removal. These holes may be either through holes for use with a hook or threaded holes using the 1/2-coarse thread series (No. 5-40UNC) as specified in ASME B1.1. When a lantern ring is installed, the packing box shall be tapped opposite the centre of the installed lantern ring and shall be fitted with a threaded round or hexagon head plug ≥ DN 8 (NPS 1/4). The plug shall be in accordance with ASME B16.11. In order to accommodate the lantern ring, the packing box depth shall be at least equivalent to that of a minimum of three uncompressed rings of packing above the lantern ring and three uncompressed rings of packing below the lantern ring plus the length of the lantern ring.

5.9.6 The clearance between the packing box bore (inside diameter) and the outside diameter of the gland (Figure B.1) shall be nominally less than the diametrical clearance between the inside diameter of the gland and the stem diameter.

5.10 Bolting

5.10.1 Bolting for the bonnet-to-body joint shall be continuously threaded stud bolts with heavy, semi-finished hexagon nuts that are in accordance with ASME B18.2.2.

5.10.2 Yoke-to-bonnet bolting shall be either continuously threaded stud bolts or headed bolts with hexagon nuts.

5.10.3 Gland bolts shall be hinged eyebolts, headed bolts, stud bolts or studs. Hexagon nuts shall be used.

5.10.4 Bolting with diameters 25 mm and smaller shall have coarse (UNC) threads or the most nearly corresponding metric threads. Bolting with diameters larger than 25 mm shall be 8 thread series (8UN) or the most nearly corresponding metric threads. Bolt threads shall be Class 2A and nut threads shall be Class 2B, in accordance with ASME B1.1. Studs used for gland bolting shall use a Class 5 interference fit conforming to ASME B1.12.

5.11 Operation

5.11.1 Unless otherwise specified by the purchaser, the valve shall be supplied with a direct operated handwheel that opens the valve when turned in a counter-clockwise direction.

5.11.2 The handwheel shall be a spoke-rim type with a maximum of six spokes and shall be free from burrs and sharp edges. Unless otherwise specified, the handwheel shall be a one-piece casting or forging or a multi-piece carbon steel fabrication that includes other carbon steel product forms. Fabricated handwheels shall have strength and toughness characteristics comparable to that of handwheels made as one-piece castings or forgings.

5.11.3 The handwheel shall be marked with the word "OPEN" and an arrow pointing in the direction of opening, except when the handwheel size makes such marking impractical.

5.11.4 The handwheel shall be retained on the stem nut by a threaded handwheel nut.

5.11.5 If operation by a chainwheel, gearbox or power actuator is to be added to the valve, the purchaser shall specify the following, as applicable:

- for chainwheel operation, the dimension from the centreline of the valve stem to the bottom of the chain loop;
- spur or bevel gear and the position of gearing handwheel relative to the pipe axis;
- electric, hydraulic, pneumatic or other actuator type;
- maximum service temperature and pressure differential across the valve disc;
- power supply attributes for power actuators.

5.11.6 Valve-to-gearbox or power actuator flange mating dimensions shall be according to ISO 5210 or shall comply with the purchaser's specifications.

5.12 Auxiliary connections

5.12.1 Auxiliary connections are not permitted, except when specified by the purchaser.

5.12.2 Unless the purchaser specifies otherwise, the minimum nominal pipe size for auxiliary connections shall be in accordance with Table 9.

Table 9 — Auxiliary connection size

Valve size range DN	Auxiliary connection minimum size	
	DN	NPS
$50 \leq d \leq 100$	15	1/2
$150 \leq d \leq 200$	20	3/4
$250 \leq d \leq 600$	25	1

5.12.3 Unless the purchaser specifies otherwise, tapped openings for testing shall not be larger than DN 15.

5.12.4 Auxiliary connections shall be identified as indicated in Figure 3. Each of the 11 locations is designated by a letter.

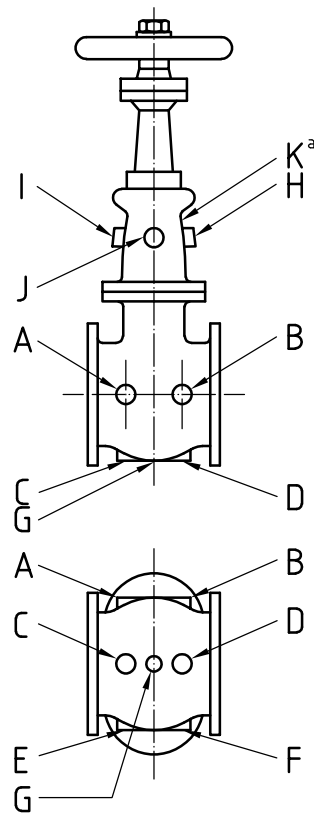

^a On same side as E and F.

Figure 3 — Location of tapped openings for auxiliary connections

5.12.5 When bosses require additional metal thickness to obtain adequate metal wall thickness, the minimum inscribed diameter of the boss shall be in accordance with Table 10.

Table 10 — Minimum inscribed boss diameter

Auxiliary connection size		Minimum inscribed diameter mm
DN	NPS	
15	1/2	38
20	3/4	44
25	1	54
32	1 1/4	64
40	1 1/2	70

5.12.6 The wall of the valve may be tapped for a pipe connection if the metal thickness is thick enough to allow the effective thread length, L , shown in Figure 4 and given in Table 11. Where the thread length is insufficient or the tapped hole needs reinforcement, a boss shall be added as specified in 5.12.5. Pipe threads shall be of the taper style in accordance with either ASME B1.20.1 or ISO 7-1-Rc.

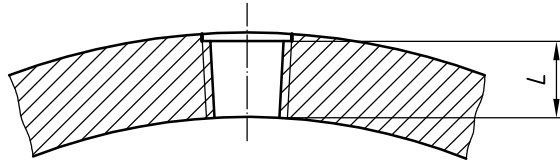

Figure 4 — Thread length for auxiliary connections

Table 11 — Pipe connection thread length

Auxiliary connection size		Minimum thread length L mm
DN	NPS	
15	1/2	14
20	3/4	14
25	1	18
32	1 1/4	18
40	1 1/2	19

5.12.7 Sockets for socket welding connections may be provided if the metal is thick enough to accommodate the depth of socket and remaining wall as shown in Figure 5 and given in Table 12. Where the wall thickness is insufficient for the socket welding connection, a boss shall be added as specified in 5.12.5. The length of the leg of the connection attachment weld shall be 1,09 times the nominal pipe wall thickness of the auxiliary connection or 3 mm, whichever is the greater.

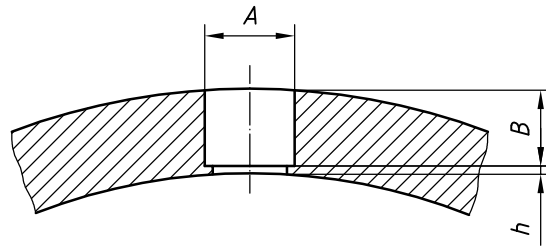

Figure 5 — Socket welding for auxiliary connections

Table 12 — Socket dimensions

Auxiliary connection size		A_{min}	B_{min}	h_{min}
DN	NPS	mm	mm	mm
15	1/2	22	5	1,5
20	3/4	27	6	1,5
25	1	34	6	1,5
32	1 1/4	43	6	1,5
40	1 1/2	49	6	1,5

5.12.8 Auxiliary connections may be attached by butt-welding directly to the wall of the valve as shown in Figure 6. Where the size of the opening is such that reinforcement is necessary, a boss shall be added as specified in 5.12.5.

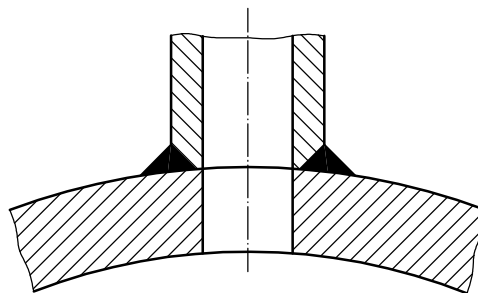

Figure 6 — Butt-welding for auxiliary connections

6 Materials

6.1 Materials other than trim materials

Materials for body, bonnet and valve parts other than trim items shall be selected from Table 13.

Table 13 — Materials for parts other than trim items

Part	Material
Body and bonnet	As selected from ASME B16.34.
Gate	Steel, at least equal in corrosion resistance to that of the body material.
Yoke, separate	Carbon steel or same material as the bonnet.
Bolting: body to bonnet	Bolts shall be ASTM A193-B7 and nuts shall be ASTM A194-2H. For services where corrosion is a concern, bolts to ASTM A193-B8 or B8M may be used and nuts to ASTM A194-B8 or B8M may be used, unless otherwise specified by the purchaser. For service temperatures below $-29\text{ }^{\circ}\text{C}$ or above $454\text{ }^{\circ}\text{C}$, the purchase order shall specify the bolting material.
Bonnet gasket	The metallic portion exposed to the service environment shall be of a material that has a corrosion resistance at least equal to that of the body material.
Bolting: gland and yoke	Bolting material at least equal to ASTM A307-Grade B.
Seat ring	As in Table 14, except that when weld deposited facings are used, the base material shall be of similar corrosion resistance as the body material.
Gland flange	Steel.
Gland	Material with melting point above $955\text{ }^{\circ}\text{C}$.
Packing	Suitable for steam and petroleum fluids for temperature range from $-29\text{ }^{\circ}\text{C}$ to $538\text{ }^{\circ}\text{C}$. Shall contain a corrosion inhibitor.
Lantern ring	Material having corrosion resistance at least equal to that of the body material.
Stem nut	Austenitic ductile iron or copper alloy with melting point above $955\text{ }^{\circ}\text{C}$.
Handwheel	Malleable iron, carbon steel, or ductile iron.
Handwheel nut (retaining)	Steel, malleable iron, ductile iron, or non-ferrous copper alloy
Pipe plugs	Nominal composition shall be the same as the shell material. Cast iron plugs shall not be used.
Bypass piping and valves	Nominal composition shall be the same as the shell material.
Pin, double disk stem to gate	Austenitic stainless steel.
Identification plate	Austenitic stainless steel or nickel alloy attached to the valve by corrosion-resistant fasteners or by welding.

6.2 Trim materials

6.2.1 Trim items include the stem, the gate seat surfaces, the body or seat ring seat surfaces and the backseat stem contact surface. The trim materials shall be in accordance with Table 14 unless other materials are agreed upon between the purchaser and manufacturer. The trim combination number, CN, identifies both the stem material and the associated seating surfaces.

Table 14 — Basic trim materials

Part	Combination number	Material description	Brinell hardness
Stem ^a	1, 4, 5, 5A, 6, 7, 8 or 8A	13Cr	200 min./275 max.
	2 or 15	18Cr-8Ni	c
	3	25Cr-20Ni	c
	9, 11 or 11A	NiCu alloy	c
	10, 12, 12A or 16	18Cr-8Ni-Mo	c
	13, 14, 14A or 18	19Cr-29Ni	c
	17	18Cr-10Ni-Cb	c
Seating surfaces ^b	1	13Cr	250 min.
	2	18Cr-8Ni	c
	3	25Cr-20Ni	c
	4	13Cr	750 min.
	5	HF	350 min.
	5A	HFA	350 min.
	6	13Cr/CuNi	250 min./175 min.
	7	13Cr/13Cr	300 min./750 min.
	8	13Cr/HF	250 min./350 min.
	8A	13Cr/HFA	250 min./350 min.
	9	NiCu alloy	c
	10	18Cr-8Ni-Mo	c
	11	NiCu alloy/HF	c / 350 min.
	11A	NiCu alloy/HFA	c / 350 min.
	12	18Cr-8Ni-Mo/HF	c / 350 min.
	12A	18Cr-8Ni-Mo/HFA	c / 350 min.
	13	19Cr-29Ni	c
	14	19Cr-29Ni/HF	c / 350 min.
14A	19Cr-29Ni/HFA	c / 350 min.	
	15, 16, 17 or 18	HF	350 min.

Cr = Chromium; Ni = Nickel; Co = Cobalt; Mo = Molybdenum; Cb = Columbium; Cu = Copper.

HF = Hard Facing using CoCr welding alloy. HFA = Hard Facing using NiCr welding alloy.

Free machining grades of 13Cr are not used.

For CN 1, a differential hardness of at least 50 Brinell points is required between mating surfaces.

For seating surfaces, single material entries designate the same material for both seating surfaces.

For seating surfaces, dual entries do not designate a particular seating surface.

^a Stems are wrought material.

^b Backseat surfaces, Figure B.1, Key 11, for CN 1 and CN 4 to CN 8, have a minimum hardness of 250 HB.

^c Hardness is not specified.

6.2.2 The trim material shall be the manufacturer's standard trim material for the combination number, CN, specified in the purchase order. For a specified CN in a purchase order an alternative CN may be furnished in accordance with Table 15. However, it is not permissible to furnish a listed specified CN when an alternative CN is specified in a purchase order without agreement from the purchaser.

Table 15 — Trim combination numbers

Specified CN	Alternative CN
1	8 or 8A
2	10
5A	5
6	8
8A	8

6.3 Welding for fabrication and repair

6.3.1 When fabrication welds are permitted by a purchaser, the welds joining pressure shell materials forming valve bodies or bonnets shall be joined by full penetration butt-welding. For such fabrications, the welding operator and welding procedure shall be qualified in accordance with ISO 9606-1 and ISO 15607, ISO 15609-1, ISO 15614-1, ISO 15614-2 and ISO 15610 or the rules of ASME-BPVC-IX. Alignment rings, integral or loose, used as welding aids shall be completely removed following welding, with care being taken that the minimum wall thickness is maintained. Heat treatment, following welding, to ensure that the valve body or bonnet materials are suitable for the full range of service conditions, shall be performed as required by the material specification. These requirements do not apply for seal welds or attachment welds such as those for backseat bushings, seat rings, lifting lugs and auxiliary connections.

6.3.2 Defects in the cast or forged valve pressure shell materials that are revealed during manufacturing operations or testing may be repaired as permitted by the most nearly applicable specification for forgings or castings.

7 Testing, inspection and examination

7.1 Pressure tests

Each valve shall be given a shell pressure test, a seat closure test and a stem backseat test in accordance with the requirements of ISO 5208, except as modified herein. Sealing compounds, greases or oils shall be removed from seating surfaces prior to pressure testing. It is permissible, however, for a film of oil that is not heavier than kerosene to be applied to prevent sealing surfaces from galling.

7.1.1 Shell test

7.1.1.1 The shell test shall be at a pressure no less than 1,5 times the pressure corresponding to the valve 38 °C pressure rating. The packing gland shall be adjusted so as to maintain the test pressure. For this test, the valve shall be in the partly open position.

7.1.1.2 The duration of the shell test — the minimum period of time that the shell test pressure is to be sustained — shall be in accordance with Table 16.

Table 16 — Duration of pressure tests

Valve size range DN	Shell test duration	Closure test duration	Backseat test duration
	s	s	s
DN ≤ 50	15	15	15
65 ≤ DN ≤ 150	60	60	60
200 ≤ DN ≤ 300	120	120	60
350 ≤ DN	300	120	60

7.1.1.3 Over the duration of the shell test there shall be no visually detectable leakage through the shell wall or at the bonnet gasket.

7.1.2 Closure tightness test

7.1.2.1 The closure tightness test for each valve shall be either of the following:

- a) a gas leakage test for valves DN ≤ 100 with Class ≤ 1 500 and for valves DN > 100 with Class ≤ 600, with the test gas at a pressure between 400 kPa (4 bar) and 700 kPa (7 bar);
- b) a liquid leakage test for valves DN ≤ 100 with Class > 1500 and for valves DN > 100 with Class > 600 with the test liquid at a pressure not less than 1,1 times the maximum allowable valve pressure rating at 38 °C.

7.1.2.2 A closure tightness test shall be applied in one direction at a time for each seating direction. The test method shall include filling the upstream side of the valve, the body cavity between the seats and the bonnet cavity with test fluid.

7.1.2.3 The duration of the closure tightness test — the minimum period of time that the test pressure is to be sustained for the purpose of obtaining a seat closure leakage measurement — shall be in accordance with Table 16.

7.1.2.4 Over the duration of the closure tightness test, the maximum permitted leakage rate past the valve seats shall be in accordance with Table 17. For the gas test, zero leakage is defined as less than 3 mm³ (1 bubble) leakage over the specified test duration. For the liquid test, zero leakage is defined as no visible leakage over the specified test duration.

Table 17 — Closure leakage rate

Valve size range DN	Maximum allowable gas leakage rate ^a		Maximum allowable liquid leakage rate ^a	
	mm ³ /s	bubbles/s	mm ³ /s	drops/s
DN ≤ 50	0	0	0	0
65 ≤ DN ≤ 150	25	0,4	12,5	0,2
200 ≤ DN ≤ 300	42	0,7	20,8	0,4
350 ≤ DN	58	0,9	29,2	0,5

^a The manufacturer may choose either method of quantifying leakage. It is recognized that the unit conversions are inexact.

7.1.2.5 Throughout the duration of the closure tightness test there shall be no visible evidence of leakage through the gate proper or from behind the installed seat rings.

7.1.2.6 When volumetric devices are used to measure seat leakage rates, they shall be calibrated to yield results equivalent to those of Table 17 for the valves under test. These devices shall be calibrated with the same test fluid, at the same temperature, as used for the valve closure tests.

7.1.2.7 Valves for which gas tests are specified in 7.1.2.1 a) shall have valve closure elements that are designed to sustain pressure loads corresponding to the conditions of the liquid test according to 7.1.2.1 b), and shall have the capability of meeting the liquid leakage requirements specified in Table 17. This shall be demonstrated by records of successful high pressure closure tests available for examination by the purchaser.

7.1.2.8 A block-and-bleed closure tightness test may be specified by a purchaser. Block-and-bleed closure requires that the two gate valve seating surfaces, with the disc in the closed position, block flow into the body cavity from both valve ends. For block-and-bleed seat tightness testing, pressure shall be applied successively (not simultaneously) to each side of the closure member through the respective valve end port. Leakage past the seating surface, into the body cavity, shall be determined either at the packing chamber (with no packing installed) or through a tapped opening between the seats. Closure tightness shall be measured with the valve stem vertical. The leakage rate from either seat shall not exceed that specified in Table 17.

7.1.3 Backseat tightness test

7.1.3.1 The backseat test shall be either a gas test at a pressure in accordance with 7.1.2.1 a) or a liquid test at a pressure in accordance with 7.1.2.1 b).

7.1.3.2 The stem backseat shall be engaged and the packing gland bolting shall be loose during the backseat test. Visible backseat leakage is not permitted over the duration of the test.

7.1.3.3 The gland bolting shall be retightened following the backseat test.

7.1.3.4 The duration of the backseat test — the minimum period of time that the test pressure is to be sustained for the purpose of obtaining a backseat closure leakage measurement — shall be in accordance with Table 16.

7.1.4 Optional closure tightness test

7.1.4.1 A high pressure liquid closure test is not required for all valves (see 7.1.2.1). It is, however, an option that the purchaser may specify. All valve closure structures shall be designed to sustain the pressures associated with this test (see 7.1.2.7).

7.1.4.2 The test liquid shall be at a pressure of 1,1 times the valve pressure rating at 38 °C.

7.1.4.3 The duration of the optional closure test — the minimum period of time that the test pressure is to be sustained for the purpose of obtaining a seat closure leakage measurement — shall be in accordance with Table 16.

7.1.4.4 The maximum leakage rate over the duration of the test shall be in accordance with Table 17.

7.2 Inspection

7.2.1 Extent of inspection

The extent of the purchaser's inspection may be specified in the purchase order and, unless otherwise indicated, shall be limited to the following:

- inspection of the valve assembly to ensure compliance with the specifications of the purchase order, which may include the specified non-destructive methods of examination;
- witnessing the required and, if specified, optional pressure tests and examinations;
- review of mill test reports and, if specified, non-destructive examination records and radiographs.

7.2.2 Site inspection

7.2.2.1 If a purchase order requires purchaser's witnessing of tests and examinations at the valve manufacturer's factory, the purchaser's inspector shall have free access to those parts of the factory concerned with the manufacture of the valves when work on the order is under way.

7.2.2.2 If a purchase order requires examinations that include valve bodies or bonnets manufactured at locations other than the valve manufacturer's factory, these components shall be available for inspection at the location where they are being manufactured.

7.3 Examination

7.3.1 For each valve, the items listed in Annex A shall be checked by the manufacturer before release for shipment.

7.3.2 The valve manufacturer shall perform a visual examination of all castings of bodies, bonnets, covers and closure elements to ensure conformance with the surface condition requirements of MSS-SP-55.

7.3.3 The valve manufacturer shall examine each valve to assure compliance with this International Standard.

7.3.4 All examinations shall be performed in accordance with written procedures that comply with the applicable standards.

7.4 Supplementary examination

Supplementary types of examination are required only if specified in the purchase order. Magnetic particle, radiographic, liquid penetrant and ultrasonic examination of castings or forgings may be specified as either the purchaser's own procedures and acceptance standards or those standardized in ASME B16.34:1996, Part 8.

8 Marking

8.1 Legibility

Each valve manufactured in accordance with this International Standard shall be clearly marked in accordance with ISO 5209, except that the requirements of this clause shall apply.

8.2 Body marking

8.2.1 For both flanged end and butt-welding end valves, the mandatory body markings, subject to the provisions of 8.2.2, shall be as follows:

- manufacturer's name or trade mark;
- body material;
- pressure Class designation number, e.g. 150;
- nominal size, as either DN followed by the appropriate size number, e.g. DN 500, or the NPS number, e.g. 20, for valves drilled for inch end flange bolting.

8.2.2 For valves smaller than DN 50, if the size or shape of the valve body prevents the inclusion of all the required markings, one or more may be omitted, provided that they are shown on the identification plate. The markings which may be omitted are the following:

- nominal size;

- pressure Class designation;
- body material.

8.3 Ring joint marking

Body end flanges require marking when the end flanges are grooved for ring joint assembly. When grooved for ring joint assembly, the ring joint gasket number (e.g. R25) shall be marked on the rim of both end flanges.

For ring joint gasket numbers, see ASME B16.5.

8.4 Identification plate marking

The identification plate marking shall include

- the manufacturer's name,
- pressure rating designation e.g. Class 150,
- manufacturer's identification number,
- maximum pressure at 38 °C,
- limiting temperature, if applicable,
- limiting pressure, if applicable,
- trim identification (see Table 14 for abbreviations), and
- compliance marking, i.e. ISO 10434/API 600.

8.5 Special marking for unidirectional valves

Valves designed for, or modified to only have, unidirectional capability, i.e. capability to block flow in only one direction, shall have a separate identification plate attached to the valve body to identify the unidirectional seat. The unidirectional seat shall be shown on the identification plate in accordance with Figure 7.

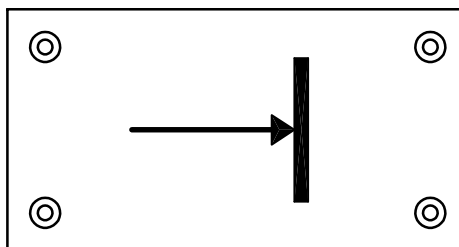

Figure 7 — Typical unidirectional valve identification plate symbol

9 Preparation for despatch

9.1 The valve shall be shipped with the lantern ring, if specified, and the packing installed. The remaining adjustment length of the packing gland at the time of shipment, with the gland tight, shall be greater than 1,5 times the packing width specified in 5.9.1.

9.2 Except for austenitic stainless steel valves and those valves of high alloy corrosion resistance, unmachined exterior valve surfaces shall be coated with aluminium colour paint.

9.3 Machined surfaces, including threads, shall be coated with an easily removable rust inhibitor.

9.4 Protective covers of wood, wood fibre, plastic or metal shall be securely affixed to the valve ends in order to safeguard the gasket surfaces or weld end preparations. The cover design shall be such that the valve cannot be installed in a pipeline with the protective cover in place.

9.5 Any plugs that could be installed in tapped openings shall be fully tightened.

9.6 At the time of shipment, the gate shall be in the closed position.

9.7 Unless otherwise specified by the purchaser, valves may be shipped loose, palletized or in boxes or crates.

Annex A (informative)

Information to be specified by the purchaser

NOTE Numbers in square brackets are references to clauses or subclauses of this International Standard.

- Nominal valve size [1] (either DN or NPS)³⁾:
- Pressure designation [1] (Class)¹⁾:
- Body cavity over-pressure evaluation [4.4]
- Body ends [5.3]¹⁾
- Butt-welding
 - Welding end configuration [5.3.2.1]:
 - End-to-end dimension [5.3.2.2]:
 - Flanged
 - Flange type [5.3.1.1] (Raised face, Flat face or Ring joint):
- Tapped openings [5.12.3]:
- Wedge style [5.6]:
- Lantern ring [5.9.5]:
- Operation other than handwheel [5.11]:
- Auxiliary connections [5.12]:
- Material [6]
- Pressure containing shell material and body to bonnet bolting [6.1]¹⁾:
 - Trim material combination number [6.2]:
 - Welding fabricated bodies or bonnets [6.3.1]
- Block-and-bleed testing [7.1.2.8]
- Optional high pressure closure tightness test [7.1.4]:
- Extent of inspection [7.2.1]:
- Witnessing tests [7.2.2]:
- Supplementary examinations [7.4]:
- Packaging for shipment [9.7]:

3) Essential information to be provided by the purchaser.

Annex B (informative)

Identification of valve terms

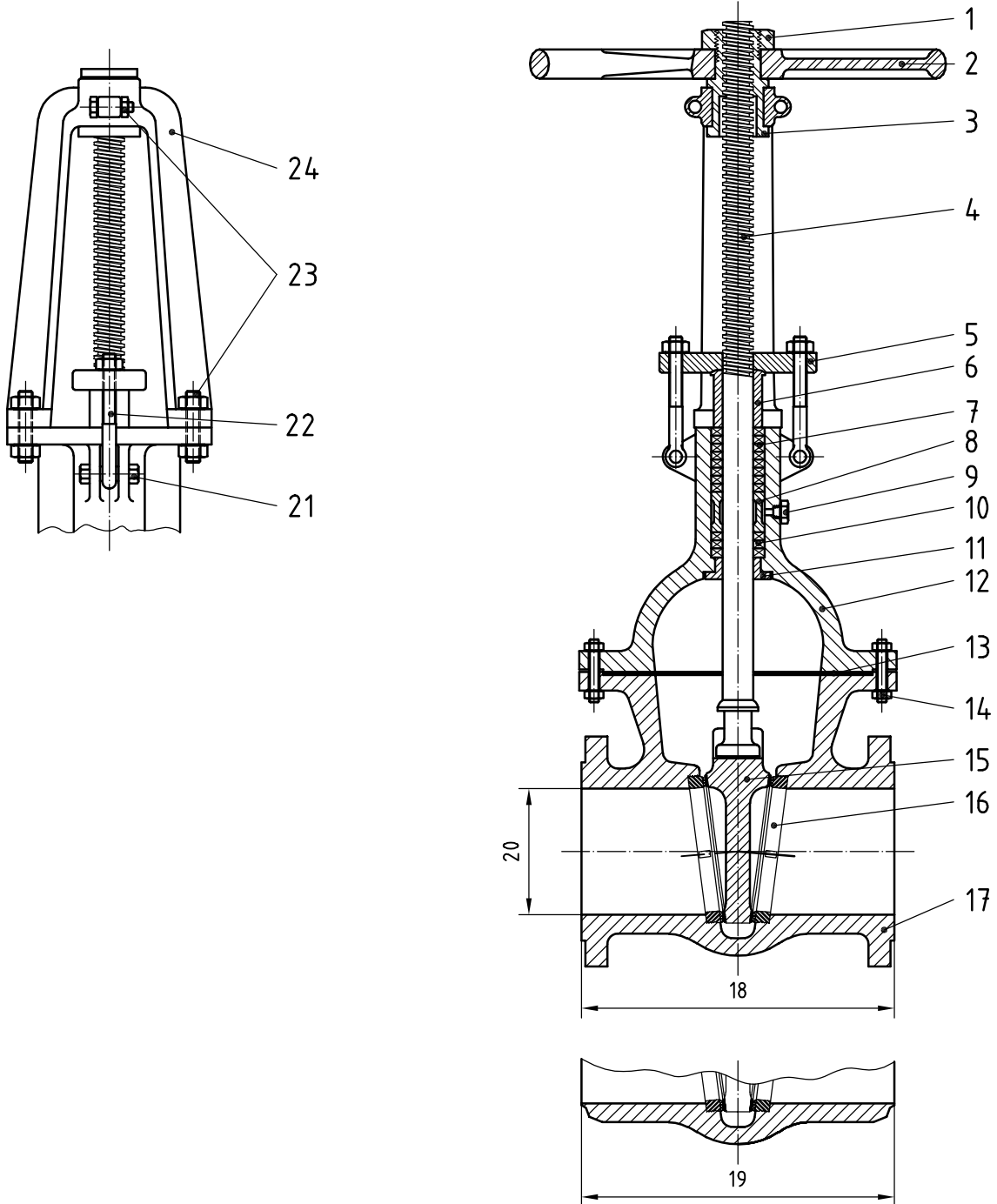

Key

1 handwheel nut	9 plug	17 body
2 handwheel	10 wiper packing	18 raised face
3 stem nut	11 backseat bushing	19 butt-welding end
4 stem	12 bonnet	20 valve port
5 gland flange	13 bonnet gasket	21 gland lug bolts and nuts
6 gland	14 bonnet bolts and nuts	22 gland bolts or gland eyebolts and nuts
7 stem packing	15 gate	23 yoke bolting
8 lantern ring	16 seat ring	24 yoke

NOTE The only purpose of this figure is to identify part names. The construction of a valve is acceptable only when it complies with this International Standard in all respects.

Figure B.1 — Valve nomenclature

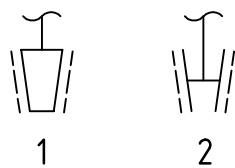

1

2



3

a) Wedge gate

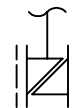

b) Double-disc gate

Key

- 1 solid one-piece wedge
- 2 flexible one-piece wedge
- 3 split wedge

Figure B.2 — Types of gate

Bibliography

- [1] ISO 4200, *Plain end steel tubes, welded and seamless — General tables of dimensions and masses per unit length*
- [2] ISO 6002, *Bolted bonnet steel gate valves*
- [3] ISO 6708:1995, *Pipework components — Definition and selection of DN (nominal size)*
- [4] ISO 10497, *Testing of valves — Fire type-testing requirements*
- [5] ISO 15761, *Steel gate, globe and check valves for sizes DN 100 and smaller, for the petroleum and natural gas industries*
- [6] API/ANSI Standard 600, eleventh edition (ISO 10434:1998), *Bolted bonnet steel gate valves for petroleum and natural gas industries*
- [7] API Standard 602, *Compact steel gate valves — Flanged, threaded, welding, and extended body ends*
- [8] ASME B16.25, *Butt-welding ends*
- [9] ASME B36.10, *Welded and seamless wrought steel pipe*
- [10] NF M87-412, *Petroleum Industry — Forged steel valves — Specifications*
- [11] MSS-SP-102, *Valve actuator attachment — Flange and driving component dimensions and performance characteristics*

