

INTERNATIONAL STANDARD

ISO 10424-1

First edition
2004-09-01

Petroleum and natural gas industries — Rotary drilling equipment —

Part 1: Rotary drill stem elements

*Industries du pétrole et du gaz naturel — Équipements de forage
rotary —*

Partie 1: Éléments de forage rotary



Reference number
ISO 10424-1:2004(E)

© ISO 2004

PDF disclaimer

This PDF file may contain embedded typefaces. In accordance with Adobe's licensing policy, this file may be printed or viewed but shall not be edited unless the typefaces which are embedded are licensed to and installed on the computer performing the editing. In downloading this file, parties accept therein the responsibility of not infringing Adobe's licensing policy. The ISO Central Secretariat accepts no liability in this area.

Adobe is a trademark of Adobe Systems Incorporated.

Details of the software products used to create this PDF file can be found in the General Info relative to the file; the PDF-creation parameters were optimized for printing. Every care has been taken to ensure that the file is suitable for use by ISO member bodies. In the unlikely event that a problem relating to it is found, please inform the Central Secretariat at the address given below.

© ISO 2004

All rights reserved. Unless otherwise specified, no part of this publication may be reproduced or utilized in any form or by any means, electronic or mechanical, including photocopying and microfilm, without permission in writing from either ISO at the address below or ISO's member body in the country of the requester.

ISO copyright office
Case postale 56 • CH-1211 Geneva 20
Tel. + 41 22 749 01 11
Fax + 41 22 749 09 47
E-mail copyright@iso.org
Web www.iso.org

Published in Switzerland

Contents

Page

Foreword.....	v
Introduction	vi
1 Scope	1
2 Conformance	3
2.1 Units of measurement	3
2.2 Tables and figures	3
3 Normative references	4
4 Terms, definitions, symbols and abbreviated terms	5
4.1 Terms and definitions	5
4.2 Symbols and abbreviated terms	9
5 Upper and lower kelly valves	10
5.1 General	10
5.2 Design criteria	11
5.3 Connections	13
5.4 Hydrostatic testing	14
5.5 Documentation and retention of records	16
5.6 Marking	16
5.7 Supplementary requirements	16
6 Square and hexagonal kellys	17
6.1 Size, type and dimensions	17
6.2 Dimensional gauging	17
6.3 Connections	17
6.4 Square forged kellys	18
6.5 Mechanical properties	18
6.6 Non-destructive examination	19
6.7 Marking	19
7 Drill-stem subs	24
7.1 Class and type	24
7.2 Dimensions for types A and B	24
7.3 Dimensions for type C (swivel subs)	25
7.4 Type D (lift sub) dimensions	26
7.5 Mechanical properties	26
7.6 Non-destructive examination	27
7.7 Connection stress-relief features	27
7.8 Cold working of thread roots	27
7.9 Gall-resistant treatment of threads and sealing shoulders	27
7.10 Marking	27
8 Drill collars	34
8.1 General	34
8.2 Standard steel drill collars	36
8.3 Non-magnetic drill collars	38
9 Drilling and coring bits	45
9.1 Roller bits and blade drag bits	45
9.2 Diamond drilling bits, diamond core bits and polycrystalline diamond compact (PDC) bits	46
10 Non-destructive examination of bars and tubes	50
10.1 General	50
10.2 Certification and qualification of NDE personnel	50

ISO 10424-1:2004(E)

10.3	Surface defects	50
10.4	Internal defects	52
Annex A (informative) Tables in US Customary Units		54
Bibliography		66

Foreword

ISO (the International Organization for Standardization) is a worldwide federation of national standards bodies (ISO member bodies). The work of preparing International Standards is normally carried out through ISO technical committees. Each member body interested in a subject for which a technical committee has been established has the right to be represented on that committee. International organizations, governmental and non-governmental, in liaison with ISO, also take part in the work. ISO collaborates closely with the International Electrotechnical Commission (IEC) on all matters of electrotechnical standardization.

International Standards are drafted in accordance with the rules given in the ISO/IEC Directives, Part 2.

The main task of technical committees is to prepare International Standards. Draft International Standards adopted by the technical committees are circulated to the member bodies for voting. Publication as an International Standard requires approval by at least 75 % of the member bodies casting a vote.

Attention is drawn to the possibility that some of the elements of this document may be the subject of patent rights. ISO shall not be held responsible for identifying any or all such patent rights.

ISO 10424-1 was prepared by Technical Committee ISO/TC 67, *Materials, equipment and offshore structures for petroleum, petrochemical and natural gas industries*, Subcommittee SC 4, *Drilling and production equipment*.

ISO 10424 consists of the following parts, under the general title *Petroleum and natural gas industries — Rotary drilling equipment*:

- *Part 1: Rotary drill stem elements*
- *Part 2: Threading and gauging of rotary shouldered thread connections*

Introduction

The function of this part of ISO 10424 is to define the design and the mechanical properties of the material required for rotary drill stem elements. It also defines the testing required to verify compliance with these requirements. As rotary drill stem elements are very mobile, moving from rig to rig, design control is an important element required to ensure the interchangeability and performance of product manufactured by different sources.

A major portion of this part of ISO 10424 is based upon API Spec 7, 40th edition, November 2001. However, API Spec 7 does not define the nondestructive testing requirements of materials used to manufacture the drill stem components covered by this part of ISO 10424. This part of ISO 10424 does address these requirements.

Users of this part of ISO 10424 should be aware that further or differing requirements may be needed for individual applications. This part of ISO 10424 is not intended to inhibit a vendor from offering, or the purchaser from accepting, alternative equipment or engineering solutions for the individual application. This may be particularly applicable where there is innovative or developing technology. Where an alternative is offered, the vendor should identify any variations from this part of ISO 10424 and provide details.

In this part of ISO 10424, certain ISO and non-ISO standards provide the same technical result for a particular provision, however there is a market need to retain the traditional non-ISO reference.

In the running text the provision is written in the form "..... in accordance with ISO xxx.

NOTE For the purposes of this provision, non-ISO Ref yyy is equivalent to ISO xxx."

Application of a non-ISO reference cited in this manner will lead to the same results as the use of the preceding ISO reference. These documents are thus considered interchangeable in practice. In recognition of the migration of global standardization towards the use of ISO standards, it is intended that references to these alternative documents be removed at the time of the first full revision of this part of ISO 10424.

Petroleum and natural gas industries — Rotary drilling equipment —

Part 1: Rotary drill stem elements

1 Scope

This part of ISO 10424 specifies requirements for the following drill stem elements: upper and lower kelly valves; square and hexagonal kellys; drill stem subs; standard steel and non-magnetic drill collars; drilling and coring bits.

This part of 10424 is not applicable to drill pipe and tool joints, rotary shouldered connection designs, thread gauging practice, or grand master, reference master and working gauges.

A typical drill stem assembly to which this part of 10424 is applicable is shown in Figure 1.

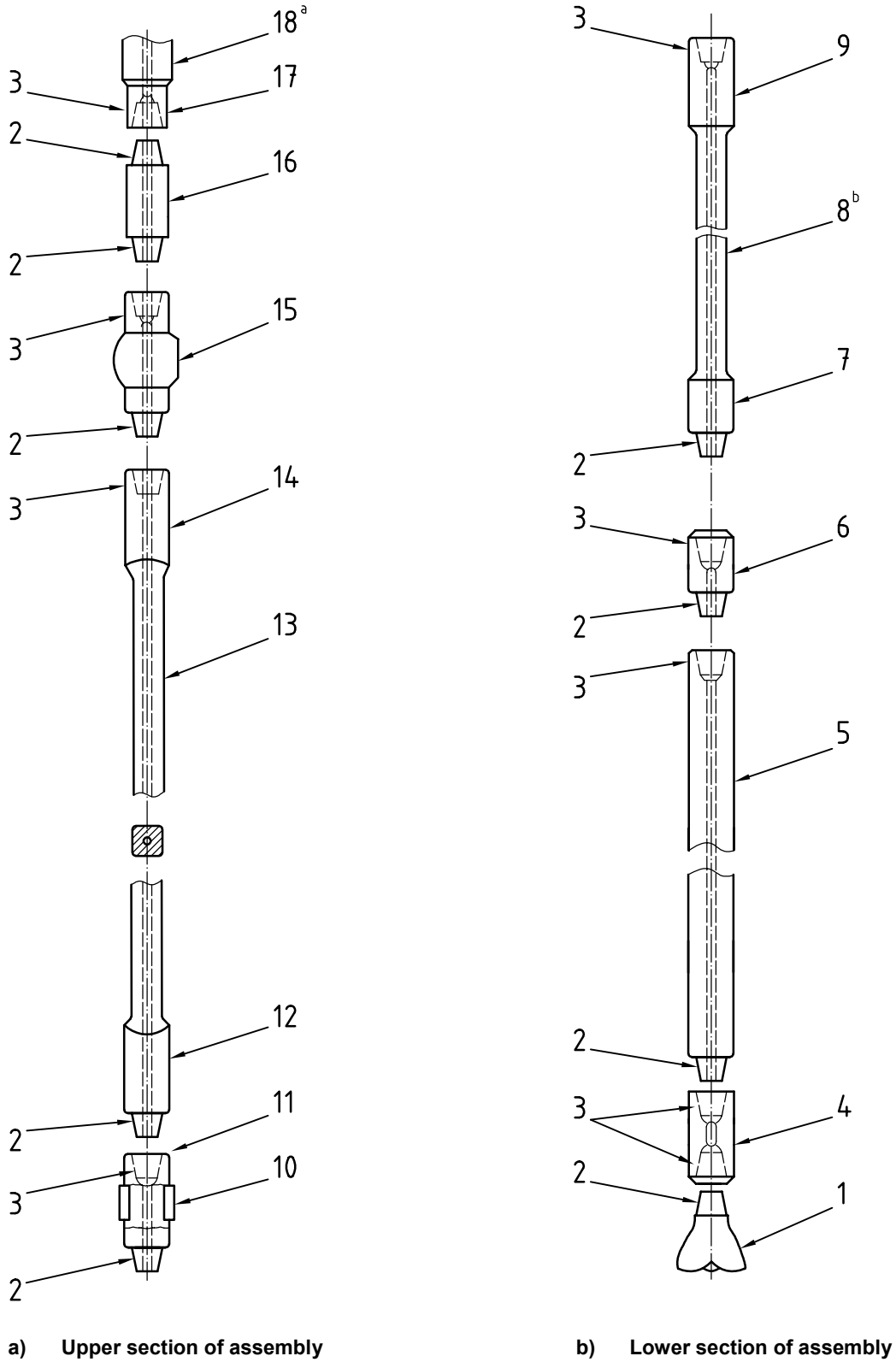

Figure 1 — Typical drill stem assembly

Key

1 bit	7 pin tool joint	13 kelly drive section
2 rotary pin connection	8 drill pipe	14 upper kelly upset
3 rotary box connection	9 box tool joint	15 upper kelly valve
4 bit sub	10 protector rubber	16 swivel sub
5 drill collar	11 lower kelly valve or kelly saver sub	17 swivel stem
6 crossover sub	12 lower kelly upset	18 swivel

^a Requirements on swivels can be found in ISO 13535.

^b Requirements on drill pipe with weld-on tool joints can be found in ISO 11961.

NOTE 1 For the purposes of the provision in footnote a, API Specs 8A and 8C are equivalent to ISO 13535.

NOTE 2 For the purposes of the provision in footnote b, API Specs 5D and 7 are equivalent to ISO 11961.

NOTE 3 All connections between lower kelly upset and the bit are RH.

NOTE 4 All connections between upper kelly upset and swivel are LH.

Figure 1 — Typical drill stem assembly (continued)

2 Conformance

2.1 Units of measurement

In this International Standard, data are expressed in both the International System (SI) of units and the United States Customary (USC) system of units. For a specific order item, it is intended that only one system of units be used, without combining data expressed in the other system.

Products manufactured to specifications expressed in either of these unit systems shall be considered equivalent and totally interchangeable. Consequently, compliance with the requirements of this International Standard as expressed in one system provides compliance with requirements in the other system.

For data expressed in the SI, a comma is used as the decimal separator and a space as the thousands separator. For data expressed in the USC system, a dot is used as the decimal separator and a space as the thousands separator.

Data within the text of this International Standard are expressed in SI units followed by data in USC units in parentheses.

2.2 Tables and figures

Separate tables for data expressed in SI units and in USC units are given. The tables containing data in SI units are included in the text and the tables containing data in USC units are given in Annex A. For a specific order item, only one unit system shall be used.

Figures are contained in the text of the clause concerning the particular product, and express data in both SI and USC units.

3 Normative references

The following referenced documents are indispensable for the application of this document. For dated references, only the edition cited applies. For undated references, the latest edition of the referenced document (including any amendments) applies.

ISO 148, *Steel — Charpy impact test (V notch)*

ISO 3452, *Non-destructive testing — Penetrant inspection — General principles*

ISO 6506-1, *Metallic materials — Brinell hardness test — Part 1: Test method*

ISO 6892, *Metallic materials — Tensile testing at ambient temperature*

ISO 9303, *Seamless and welded (except submerged arc-welded) steel tubes for pressure purposes — Full peripheral ultrasonic testing for the detection of longitudinal imperfections*

ISO 9934-1, *Non-destructive testing — Magnetic particle testing — Part 1: General principles*

ISO 9712, *Non-destructive testing — Qualification and certification of personnel*

ISO 13665, *Seamless and welded steel tubes for pressure purposes — Magnetic particle inspection of the tube body for the detection of surface imperfections*

ISO 15156-1, *Petroleum and natural gas industries — Materials for use in H₂S-containing environments in oil and gas production — Part 1: General principles for selection of cracking-resistant materials*

ISO 15156-2, *Petroleum and natural gas industries — Materials for use in H₂S-containing environments in oil and gas production — Part 2: Cracking-resistant carbon and low alloy steels, and the use of cast irons*

ISO 15156-3, *Petroleum and natural gas industries — Materials for use in H₂S-containing environments in oil and gas production — Part 3: Cracking-resistant CRAs (corrosion-resistant alloys) and other alloys*

API¹⁾ RP 7G, *Drill Stem Design and Operating Limits*

API Spec 7, *Rotary Drill Stem Elements*

ASTM²⁾ A 262, *Standard Practices for Detecting Susceptibility to Intergranular Attack in Austenitic Stainless Steels*

ASTM A 434, *Standard Specification for Steel Bars, Alloy, Hot-Wrought or Cold-Finished, Quenched and Tempered*

ASTM E 587, *Standard Practice for Ultrasonic Angle-Beam Examination by the Contact Method*

1) American Petroleum Institute, 1220 L Street, N.W., Washington, D.C. 20005, USA

2) American Society for Testing and Materials, 100 Barr Harbor Drive, West Conshohocken, PA 19428, USA

4 Terms, definitions, symbols and abbreviated terms

4.1 Terms and definitions

For the purposes of this document, the following terms and definitions apply.

4.1.1

amplitude

vertical height of the A-scan received signal, measured from base to peak or peak to peak

4.1.2

A-scan display

ultrasonic instrument display in which the received signal is displayed as a vertical height or “pip” from the horizontal-sweep time trace, while the horizontal distance between two signals represents the material distance for time of travel between the two conditions causing the signals

4.1.3

back reflection

signal received from the back surface of a surface test object

4.1.4

bevel diameter

outer diameter of the contact face of the rotary shouldered connection

4.1.5

bit sub

sub, usually with two box connections, that is used to connect the bit to the drill stem

4.1.6

box connection

threaded connection on oilfield tubular goods (OCTG) that has internal (female) threads

4.1.7

bending strength ratio

BSR

ratio of the section modulus of a rotary shouldered box at the point in the box where the pin ends when made up, to the section modulus of the rotary shouldered pin at the last engaged thread

4.1.8

calibration system

documented system of gauge calibration and control

4.1.9

cold working

plastic deformation of the thread roots of a rotary shouldered connection, of radii and of cylindrical sections at a temperature low enough to ensure or cause permanent strain of the metal

4.1.10

decarburization

loss of carbon from the surface of a ferrous alloy as a result of heating in a medium that reacts with the carbon at the surface

4.1.11

depth prove-up

act of grinding a narrow notch across a surface-breaking indication until the bottom of the indication is located and then measuring the depth of the indication with a depth gauge for comparison to acceptance criteria

4.1.12

drift

gauge used to check minimum internal diameter of drill stem components

4.1.13

drill collar

thick-walled pipe used to provide stiffness and concentration of mass at or near the bit

4.1.14

drill pipe

length of tube, usually steel, to which special threaded connections called tool joints are attached

4.1.15

forge, verb

〈hammer〉 plastically deform metal, usually hot, into desired shapes by the use of compressive force, with or without dies

4.1.16

forging, noun

〈product〉 shaped metal part formed by the forging method

4.1.17

full-depth thread

thread in which the thread root lies on the minor cone of an external thread or on the major cone of an internal thread

4.1.18

gauge point

plane perpendicular to the thread axis in API rotary shouldered connections

NOTE The gauge point is located 15,9 mm (0.625 in) from the shoulder of the product pin.

4.1.19

gas-tight

capable of holding gas without leaking under the specified pressure for the specified length of time

4.1.20

heat, noun

metal produced by a single cycle of a batch melting process

4.1.21

H₂S trim

all components, except external valve body, meeting the H₂S service requirements of ISO 15156-2 and ISO 15156-3

NOTE For the purposes of this provision, NACE MR0175 is equivalent to ISO 15156-2 and ISO 15156-3.

4.1.22

kelly

square or hexagonally shaped steel pipe connecting the swivel to the drill pipe that moves through the rotary table and transmits torque to the drill stem

4.1.23

kelly saver sub

short rotary sub that is made up onto the bottom of the kelly to protect the pin end of the kelly from wear during make-up and break-out operations

4.1.24**label**

dimensionless designation for the size and style of a rotary shouldered connection

4.1.25**length of box thread****LBT**

length of threads in the box measured from the make-up shoulder to the intersection of the non-pressure flank and crest of the last thread with full thread depth

4.1.26**lot**

pieces of steel, with the same nominal dimensions and from a single heat, which are subsequently heat-treated as part of the same continuous operation (or batch)

4.1.27**low-stress steel stamps**

steel stamps that do not contain any sharp protrusions on the marking face

4.1.28**lower kelly valve****kelly cock**

essentially full-opening valve installed immediately below the kelly, with outside diameter equal to the tool joint outside diameter, that can be closed to remove the kelly under pressure and can be stripped in the hole for snubbing operations

4.1.29**make-up shoulder**

sealing shoulder on a rotary shouldered connection

4.1.30**non-pressure flank – box**

thread flank closest to the make-up shoulder where no axial load is induced from make-up of the connection or from tensile load on the drill stem member

4.1.31**non-pressure flank – pin**

thread flank farthest from the make-up shoulder where no axial load is induced from make-up of the connection or from tensile load on the drill stem member

4.1.32**out-of-roundness**

difference between the maximum and minimum diameters of the bar or tube, measured in the same cross-section, and not including surface finish tolerances outlined in 8.1.4

4.1.33**pin end**

external (male) threads of a threaded connection

4.1.34**process of quenching**

hardening of a ferrous alloy by austenitizing and then cooling rapidly enough so that some or all of the austenite transforms to martensite

4.1.35**process of tempering**

reheating a quench-hardened or normalized ferrous alloy to a temperature below the transformation range and then cooling to soften and remove stress

4.1.36

reference dimension

dimension that is a result of two or more other dimensions

4.1.37

rotary shouldered connection

connection used on drill stem elements, which has coarse, tapered threads and sealing shoulders

4.1.38

stress-relief features

modification performed on rotary shouldered connections by removing the unengaged threads on the pin or box to make the joint more flexible and to reduce the likelihood of fatigue-cracking in highly stressed areas

4.1.39

sub

short drill stem members with different rotary shouldered connections at each end for the purposes of joining unlike members of the drill stem

4.1.40

swivel

device at the top of the drill stem that permits simultaneous circulation and rotation

4.1.41

tensile strength

maximum tensile stress that a material is capable of sustaining that is calculated from the maximum load during a tensile test carried to rupture and the original cross-sectional area of the specimen

4.1.42

tensile test

mechanical test used to determine the behaviour of material under axial loading

4.1.43

test pressure

pressure above working pressure used to demonstrate structural integrity of a pressure vessel

4.1.44

thread form

thread profile in an axial plane for a length of one pitch

4.1.45

tolerance

amount of variation permitted

4.1.46

tool joint

heavy coupling element for drill pipe having coarse, tapered threads and sealing shoulders

4.1.47

upper kelly valve

kelly cock

valve immediately above the kelly that can be closed to confine pressures inside the drill stem

4.1.48

working pressure

pressure to which a particular piece of equipment is subjected during normal operation

4.1.49

working temperature

temperature to which a particular piece of equipment is subjected during normal operation

4.2 Symbols and abbreviated terms

D	outside diameter
D_{BP}	diameter baffle plate recess
D_C	distance across corners, forged kellys
D_{CC}	distance across corners, machined kellys
D_F	bevel diameter
D_{FL}	distance across flats on kellys
D_{FR}	diameter float valve recess
D_E	diameter elevator groove
D_L	outside diameter lift shoulder
D_{LR}	outside diameter, kelly lower upset
D_P	elevator recess diameter
D_R	outside diameter, reduced section
D_S	diameter slip groove
D_U	outside diameter, upper kelly upper upset
d	inside diameter
d_b	inside bevel
L	overall length
L_D	length kelly drive section
L_{FV}	length float valve assembly
L_G	minimum length kelly sleeve gauge
L_L	lower upset length kellys
L_R	depth of float valve recess
L_U	upper upset length kellys
l_E	elevator groove recess depth
l_S	slip recess groove depth
R	radius

ISO 10424-1:2004(E)

R_C	corner radius forged kelly
R_{CC}	corner radius machined kelly
R_H	maximum fillet radius hexagonal kelly sleeve gauge
R_S	maximum fillet radius square kelly sleeve gauge
T	diameter of baffle plate recess
t	minimum wall thickness
$\angle \alpha$	angle of run-out of elevator recess
$\angle \beta$	angle of run-out of slip recess
AMMT	American macaroni tubing style of thread design
AMT	alternative abbreviation for the American macaroni tubing style of thread design
BSR	bending strength ratio
dB	decibel
FH	API full-hole style of thread design
HBW	Brinell hardness
LH	left hand
MT	magnetic particle testing
MT	macaroni tubing style of thread design
NC	API number style of thread design
NDT	non-destructive testing
PT	liquid penetrant testing
REG	API regular style of thread design
RH	right hand
UT	ultrasonic testing

5 Upper and lower kelly valves

5.1 General

This part of ISO 10424 specifies the minimum design, material, inspection and testing requirements for upper and lower kelly valves. This part of ISO 10424 also applies to drill-stem safety valves used with overhead drilling systems. It applies to valves of all sizes with rated working pressures of 34,5 MPa through 103,5 MPa (5 000 psi through 15 000 psi) used in normal service conditions (H_2S service conditions are addressed as a supplemental requirement, see 5.7). Rated working temperatures are $-20\text{ }^\circ\text{C}$ ($-4\text{ }^\circ\text{F}$) and above for valve bodies; sealing system components may have other temperature limitations.

5.2 Design criteria

5.2.1 General

The manufacturer shall document the design criteria and analysis for each type of valve produced under this part of ISO 10424. This documentation shall include loading conditions that will initiate material yield for the valve body with minimum material properties and tolerances under combined loading, including tension, internal pressure and torsion. Body material yield loading conditions shall be documented in either tabular form or in graphical form. The minimum design yield safety factor shall be 1,0 at the shell test pressure found in Table 1.

For the valve to have a useful fatigue life, loading conditions should be monitored to ensure they remain well below manufacturer-supplied valve body material yield conditions. Endurance load conditions, below which fatigue does not accumulate, will depend on the service conditions, primarily determined by the temperature and corrosive nature of the fluids in contact with the valve.

Table 1 — Hydrostatic testing pressures

Maximum working pressure rating MPa	Hydrostatic shell test pressure (new valves only) MPa
34,5	68,9
68,9	103,4
103,4	155,1

5.2.2 Material requirements

Where material requirements are not otherwise specified, material for equipment supplied to this part of ISO 10424 may vary depending on the application but shall comply with the manufacturer's written specifications. Manufacturer specifications shall define the following:

- a) chemical composition limits;
- b) heat treatment conditions;
- c) limits for the following mechanical properties:
 - 1) tensile strength;
 - 2) yield strength;
 - 3) elongation;
 - 4) hardness.

Minimum values for mechanical properties shall conform to material requirements for drill collars as specified in Clause 8.

5.2.3 Impact strength

5.2.3.1 Test specimen

Three longitudinal impact test specimens per heat per heat treatment lot shall be tested in accordance with ISO 148. Qualification test coupons may be integral with the components they represent, separate from the

components or a sacrificial production part. In all cases, test coupons shall be from the same heat as the components which they qualify and shall be heat-treated with the components.

NOTE For the purposes of this provision, ASTM A 370 and ASTM E 23 are equivalent to ISO 148.

Test specimens shall be removed from integral or separate qualification test coupons such that their longitudinal centreline axis is wholly within the centre 1/4-thickness envelope for a solid test coupon or within 3 mm (1/8 in) of the mid-thickness of the thickest section of a hollow test coupon.

Test specimens taken from sacrificial production parts shall be removed from the centre 1/4-thickness envelope location of the thickest section of the part.

If the test coupon is obtained from a trepanned core or other portion removed from a production part, the test coupon shall only qualify production parts that are identical in size and shape to the production part from which it was removed.

5.2.3.2 Requirements

The average impact value of the three specimens shall not be less than 42 J (31 ft-lbs), with no single value below 32 J (24 ft-lbs) when tested at -20 °C (-4 °F).

5.2.3.3 Subsize specimens

If it is necessary for subsize impact test specimens to be used, the acceptance criteria shall be multiplied by the appropriate adjustment factor listed in Table 2. Subsize test specimens of width less than 5 mm (0.197 in) shall not be permitted.

Table 2 — Adjustment factors for impact specimens

Specimen dimensions mm × mm	Adjustment factor
10 × 10	1,00
10 × 7,5	0,833
10 × 5	0,667

5.2.4 Pressure sealing performance requirements

Kelly valve and other drill-string safety valves (regardless of closure mechanism) shall be designed for either surface-only or for surface and/or downhole service. Lower kelly valves and lower safety valves used with overhead drilling systems should be designed for downhole service. The design performance requirements for pressure sealing for each service class are shown in Table 3.

Table 3 — Service class definitions

Class number	Service type	Design performance requirements for pressure sealing
Class 1 ^a	Surface only	<p>Body and any stem seal shall hold <i>internal</i> pressure equal to the shell test pressure ^b</p> <p>Closure seal shall hold pressure from <i>below</i> at a low pressure of 1,7 MPa and at a high pressure equal to the maximum rated working pressure</p>
Class 2	Surface and downhole	<p>Body and any stem seal shall hold <i>internal</i> pressure equal to the shell test pressure ^b</p> <p>Stem seal shall hold <i>external</i> pressure at a low pressure of 1,7 MPa and at a minimum high pressure of 13,8 MPa ^c</p> <p>Closure seal shall hold pressure from <i>below</i> at a low pressure of 1,7 MPa and at a high pressure equal to the maximum rated working pressure</p> <p>Closure seal shall hold pressure from <i>above</i> at a low pressure of 1,7 MPa and at a high pressure equal to the maximum rated working pressure ^d</p> <p>Sealing temperature range verified by testing ^e</p>
<p>^a Valves manufactured to the 39th and earlier editions of API Spec 7 qualify as Class 1 valves. To re-classify existing valves as Class 2 shall require testing in accordance with the requirements of 5.4.3, 5.4.4 and 5.4.5.</p> <p>^b Shell test only performed once, in accordance with the values given in Table 1, for each valve manufactured.</p> <p>^c Stem seal performance verified once for each valve design, not for each valve manufactured.</p> <p>^d Only applies to ball-type valves.</p> <p>^e Sealing temperature range verified once for each valve design, not for each valve manufactured.</p>		

5.2.5 Basic performance requirements

Kelly valves and other drill-string safety valves (regardless of closure mechanism) shall be designed to be capable of the following basic performance requirements:

- a) repeated operation in drilling mud;
- b) closing to shut off a mud flow from the drill string;
- c) sealing over the design range of temperature and tension load conditions.

5.3 Connections

5.3.1 Size and type

For all valves covered by this part of ISO 10424, end connections shall be stated on the purchase order and the corresponding bevel diameters specified for such connections shall be used.

In the case of upper and lower kelly valves, connections shall be of the size and type shown in Clause 6, Table 5 or Table 7 unless otherwise stated on the purchase order. If such connections are employed, the corresponding bevel diameters specified for such connections shall be used.

A gall-resistant treatment of zinc or manganese phosphate shall be applied to the threads and sealing shoulders of all end connections of valves manufactured from standard steel. Application of the treatment shall be after completion of all gauging. The treatment type shall be the option of the manufacturer.

Gall-resistant treatments are not readily available for non-magnetic drill collars, therefore are not required.

Cold working of threads is optional. But purchaser should consider specifying cold working of threads after thread gauging. See 8.1.7.3 for further details.

Consult manufacturer for recommended make-up torques and combined load rating of end connections and any service connections supplied (see API RP 7G Appendix A for combined loading calculations for API connections).

5.3.2 Non-destructive examination

5.3.2.1 Coverage

End connections and any service connection shall be subjected to non-destructive examination for both transverse and longitudinal defects.

5.3.2.2 Connections from standard steel

Connections manufactured from standard steel shall be examined by the wet magnetic-particle method. The examination shall be performed according to a written procedure developed by the manufacturer. The procedure shall be in accordance with ISO 9934-1 and shall be made available to the purchaser on request.

NOTE For the purposes of this provision, ASTM E 709 is equivalent to ISO 9934-1.

5.3.2.3 Connections from non-magnetic steel

Connections manufactured from non-magnetic steel shall be examined by liquid penetrant, using the visible or fluorescent solvent-removable or water-washable method. The examination shall be performed according to a written procedure developed by the manufacturer. The procedure shall be in accordance with ISO 3452 and shall be made available to the purchaser on request.

NOTE For the purposes of this provision, ASTM E 1209, ASTM E 1219, ASTM E 1220 and ASTM E 1418 are equivalent to ISO 3452.

5.4 Hydrostatic testing

5.4.1 General

Hydrostatic testing shall be conducted to the pressures as shown in Table 1. Testing shall be conducted at ambient temperature with a suitable non-corrosive, low-viscosity, low-compressibility fluid. During the pressure-holding period, timing shall start when pressure stabilization is achieved. During the test period, no visually detectable leakage is permitted, and pressure drop shall be within manufacturer's tolerance for a zero leak rate.

5.4.2 Hydrostatic shell testing

Each new valve body shall be tested to the hydrostatic test pressure by the method outlined below. Hydrostatic shell testing shall be conducted with the valve in the half-closed position. If there is a stem seal in the valve body, a low pressure test to 1,7 MPa (250 psi) shall also be conducted. Both the low pressure and high pressure tests shall be conducted in three parts:

- a) initial pressure-holding period of 3 min;

- b) reduction of pressure to zero;
- c) final pressure-holding period of not less than 10 min.

5.4.3 Tests at working pressure

5.4.3.1 General

Each valve shall have appropriate working-pressure testing, depending on the class of service defined in Table 3. This testing shall apply to all new valves and shall be conducted as specified in 5.4.3.2 and 5.4.3.3.

Working pressure test period shall be for a minimum of 5 min.

5.4.3.2 Tests at pressure from below

This testing applies to both Class 1 and Class 2 type valves.

Pressure shall be applied to the functional lower end of the valve (normally the pin end) with the valve in the closed position. Low and high pressure tests shall be conducted. The low pressure test shall be at 1,7 MPa (250 psi) and the high pressure test shall be at the maximum working-pressure rating. Open and close the valve after the high pressure test to release any trapped pressure in cavities of valve.

5.4.3.3 Tests at pressure from above

This testing applies to Class 2 type valves only.

This testing applies to valves with ball-type closure mechanisms only.

Pressure shall be applied to the functional upper end of the valve (normally the box end) with the valve in the closed position. Low and high pressure tests shall be conducted. The low pressure test shall be at 1,7 MPa (250 psi) and the high pressure test shall be at the maximum working-pressure rating. Open and close the valve after the high pressure test to release any trapped pressure in cavities of the valve, and then repeat the low pressure test.

CAUTION — After working pressure tests are completed, check to ensure that the alignment of the ball or flapper in the indicated “open position” is still within manufacturing tolerances, as misalignment can cause fluid erosion problems in field applications.

5.4.4 Design verification test for stem-seal external pressure

Each Class 2 service valve design shall have appropriate stem-seal external pressure testing as outlined below.

The test period shall be for a minimum of 5 min.

The stem-seal external pressure test applies to Class 2 type valves only, and is only required for design verification purposes. Pressure shall be applied to the outside of the valve (e.g. through a high pressure sleeve mounted over the stem seal area) with the valve in the half-open position. Low and high pressure stem-seal tests shall be conducted. The low pressure test shall be at 1,7 MPa (250 psi) and the high pressure test shall be a minimum of 13,8 MPa (2 000 psi) but may be higher, up to the rated working pressure, at the manufacturer's discretion.

5.4.5 Design verification test for sealing temperature range

This applies to Class 2 type valves only and is only required for design verification purposes.

Standard non-metallic seal systems are typically valid over the range $-10\text{ }^{\circ}\text{C}$ ($14\text{ }^{\circ}\text{F}$) to $90\text{ }^{\circ}\text{C}$ ($194\text{ }^{\circ}\text{F}$), so design verification testing shall be conducted with the valve and the test fluid at these temperature extremes, unless the purchaser specifies otherwise. Pressure testing shall be performed in accordance with 5.4.3 and 5.4.4 at both low and high temperatures, using suitable testing fluids for extreme temperature conditions.

5.5 Documentation and retention of records

The manufacturer shall maintain, and provide on request to the purchaser, documentation of inspection (dimensional, visual and non-destructive) and hydrostatic testing for each valve supplied. The manufacturer shall maintain documentation of performance verification testing for a period not less than 7 years after the last model is sold.

5.6 Marking

Kelly valves and other drill-stem safety valves manufactured in accordance with this part of ISO 10424 shall be imprinted using low-stress steel stamps or a low-stress milling process as follows:

- a) the manufacturer's name or mark, "ISO 10424-1", class of service, unique serial number, date of manufacture (month/year) and maximum rated working pressure to be applied in milled recess;
- b) the connection size and style, applied on the OD surface adjacent to connection;
- c) as appropriate, indication of the rotation direction required to position valve in the closed position on the OD surface adjacent to each valve-operating mechanism;
- d) on Class 1 type valves, indication of normal mud flow direction marked with an arrow (\rightarrow) and the word "Flow".

5.7 Supplementary requirements

5.7.1 General

The following supplementary requirements for kelly valves and other types of drill-string safety valves shall apply by agreement between the purchaser and the manufacturer and when specified on the purchase order.

5.7.2 Supplemental requirement for gas-tight sealing

Kelly valves and other types of drill-stem safety valves have not historically been designed with gas-tight sealing mechanisms. Valves that are designed to operate under these conditions are known as gas-tight valves. See 5.7.3 for optional performance verification testing that may be requested as a supplemental requirement by purchaser to verify gas-tight sealing design and for routine acceptance testing for each gas-tight valve supplied.

5.7.3 Performance verification testing of gas-tight sealing

Supplemental performance verification testing of drill-stem safety valves designed and manufactured in accordance with this part of ISO 10424 shall be carried out and/or certified by a quality organization independent of the design function. Since leak-testing at high pressure is potentially more hazardous with gas than with fluids of low compressibility, gas testing at high pressure shall be restricted to performance verification testing. Nitrogen or other suitable non-flammable gas should be used at ambient-temperature conditions. Otherwise, testing at low and high pressures shall be conducted in accordance with 5.4.3. No gas bubbles shall be observed in a 5 min test period.

For each valve manufactured to the same specifications as a valve that has been designed and verified as being capable of gas-tight sealing, a gas test at low pressure to 0,62 MPa (90 psi), using ambient-temperature air, shall be performed in accordance with appropriate subclauses in 5.4.3. No gas bubbles shall be observed in a 5 min test period.

5.7.4 Supplemental requirements for H₂S trim

If valve trim materials conform to the requirements of ISO 15156-2 and/or ISO 15156-3 for H₂S service, at conditions specified by the manufacturer, then the valve shall be designated "H₂S trim". H₂S trim may be requested as a supplemental requirement by the purchaser.

NOTE For the purposes of this provision, NACE MR0175 is equivalent to ISO 15156-2 and ISO 15156-3.

H₂S trim valves shall not be considered safe for use in a sour environment, as defined in ISO 15156-1, since the material used in the body of H₂S trim valves is not suitable for sour service.

NOTE For the purposes of this provision, NACE MR0175 is equivalent to ISO 15156-1.

5.7.5 Supplemental marking

Supplemental performance verification testing information shall be applied in a separate milled recess. Designations shall be used to indicate verified performance as follows:

- a) successful gas-tight sealing supplemental testing: "Gas-tight";
- b) H₂S trim supplemental requirement: "H₂S trim".

6 Square and hexagonal kellys

6.1 Size, type and dimensions

Kellys shall be either square or hexagonal, and conform to the sizes and dimensions in Tables 4 and 5 and Figure 2 for square kellys, or Tables 6 and 7 and Figure 3 for hexagonal kellys.

6.2 Dimensional gauging

6.2.1 Drive section

The drive section of all kellys shall be gauged for dimensional accuracy, using a sleeve gauge conforming to Table 8 and Figure 4.

6.2.2 Bore

All kelly bores shall be gauged with a drift mandrel 3,05 m (10 ft) long minimum. The drift mandrel shall have a minimum diameter equal to the specified bore of the kelly (standard or optional) minus 3,2 mm (1/8 in).

For 133,4 mm (5 1/4 in) hexagonal kellys, a standard or optional inside diameter (bore) may be specified (see Table 7).

6.3 Connections

Kellys shall be furnished with box and pin connections in the sizes and styles stipulated in Table 5 or Table 7, and shall conform with the requirements of API Spec 7.

For the lower end of 108 mm (4 1/4 in) and 133,4 mm (5 1/4 in) square kellys and for the lower end of 133,4 mm (5 1/4 in) and 152,4 mm (6 in) hexagonal kellys, two sizes and styles of connections are standard.

A gall-resistant treatment of zinc or manganese phosphate shall be applied to the threads and sealing shoulders of both the upper and lower connections. Application of the treatment shall be after completion of all gauging. The type of treatment shall be the option of the manufacturer.

6.4 Square forged kellys

Square forged kellys shall be manufactured such that the decarburized surface layer is removed in the zones defined by the radiuses joining the drive section to the upper and lower upsets and extending a minimum of 3,2 mm (1/8 in) beyond the tangency points of the radiuses.

6.5 Mechanical properties

6.5.1 General

The mechanical properties of kellys, as manufactured, shall comply with the requirements of Table 9.

6.5.2 Tensile requirements

Tensile properties shall be verified by performing a tensile test on one specimen per heat per heat treatment lot.

Tensile properties shall be determined by tests on cylindrical specimens conforming to the requirements of ISO 6892, 0,2 % offset method. Specimens of diameter 12,7 mm (0.500 in) are preferred; specimens of diameter 8,9 mm (0.350 in) and 6,4 mm (0.250 in) are acceptable alternatives for thin sections.

NOTE For the purposes of this provision, ASTM A 370 is equivalent to ISO 6892.

Tensile specimens shall be taken from the lower upset of the kelly in a longitudinal direction, having the centreline of the tensile specimen 25,4 mm (1 in) from the outside surface or mid-wall, whichever is less.

Tensile testing is not necessary or practical on the upper upset.

A minimum Brinell Hardness number of 285 shall be *prima facie* evidence of satisfactory mechanical properties in the upper upset.

The hardness test shall be made on the OD of the upper upset (Brinell Hardness in accordance with ISO 6506-1 is preferred although Rockwell C Hardness is an acceptable alternative).

NOTE For the purposes of this provision, ASTM A 370 is equivalent to ISO 6506-1.

6.5.3 Impact strength requirements

6.5.3.1 General

Charpy V-notch impact tests shall be conducted on specimens conforming to the requirements of ISO 148 and shall be conducted at a temperature of 21 °C ± 3°C (70 °F ± 5 °F). Tests conducted at lower temperatures that meet the requirements stated in 6.5.3.4 are acceptable.

NOTE For the purposes of this provision, ASTM A 370 and ASTM E 23 are equivalent to ISO 148.

6.5.3.2 Specimens

One set of 3 specimens per heat per heat-treatment lot shall be tested.

Specimens shall be taken from the lower upset at 25,4 mm (1 in) below the surface or at mid-wall, whichever is closer to the outer surface.

The specimens shall be longitudinally oriented and radially notched.

6.5.3.3 Specimen size

Specimens of full size (10 mm × 10 mm) shall be used except where there is insufficient material, in which case the next smaller standard subsize specimen obtainable shall be used.

If it is necessary to use subsize test specimens, the acceptance criteria shall be multiplied by the appropriate adjustment factor listed in Table 2. Subsize test specimens of less than 5 mm are not permitted.

6.5.3.4 Acceptance criteria

The average of the three specimens shall be 54 J (40 ft-lbs) or greater, with no single value less than 47 J (35 ft-lbs).

6.6 Non-destructive examination

Each bar or tube used to manufacture kellys shall be examined for both surface and internal defects in accordance with Clause 10 of this part of ISO 10424.

6.7 Marking

Kellys manufactured in conformance with this part of ISO 10424 shall be die-stamped on the OD of the upper upset with the following information:

- a) manufacturer's name or identifying mark;
- b) "ISO 10424-1";
- c) the size and style of the upper connection.

The lower upset shall be die-stamped on the OD with size and style of the lower connection.

EXAMPLE A 108 mm (4 1/4 in) square kelly with a 6 5/8 regular left-hand upper box connection, manufactured by A B Company, shall be marked:

On upper upset: A B Co. (or mark) ISO 10424-1 6 5/8 REG LH

On lower upset: NC50

Table 4 — Square kelly drive section

Kelly size ^a	Length drive section		Length overall		Across flats	Across corners	Across corners	Radius	Radius	Wall thickness eccentric bore
	m		m							
	Standard	Optional	Standard	Optional	mm	mm	mm	mm	mm	mm
	L_D	L_D	L	L	D_{FL}^b	D_C^c	D_{CC}	R_C	R_{CC}	t
	+0,152 -0,127	+0,152 -0,127	+0,152 0	+0,152 0			0 -0,4	± 1,6	Ref. Only	min.
63,5	11,28	—	12,19	—	63,5	83,3	82,55	7,9	41,3	11,43
76,2	11,28	—	12,19	—	76,2	100,0	98,42	9,5	49,2	11,43
88,9	11,28	—	12,19	—	88,9	115,1	112,70	12,7	56,4	11,43
108,0	11,28	15,54	12,19	16,46	108,0	141,3	139,70	12,7	69,8	12,06
133,4	11,28	15,54	12,19	16,46	133,3	175,4	171,45	15,9	85,7	15,88

NOTE See Figure 2 for configuration of square drive section.

- ^a Size of square kellys is the same as the dimension D_{FL} across flats (distance between opposite faces) as given in Column 6.
- ^b Tolerances on D_{FL} , sizes 63,5 to 88,9 inclusive: $+2,0_0$ mm ; sizes 108,0 to 133,3 inclusive: $+2,40_0$ mm. See 6.2 for sleeve test.
- ^c Tolerances on D_C , sizes 63,5 to 88,9 inclusive: $+3,2_0$ mm ; sizes 108,0 to 133,3 inclusive: $+4,0_0$ mm.

Dimensions in millimetres (inches)

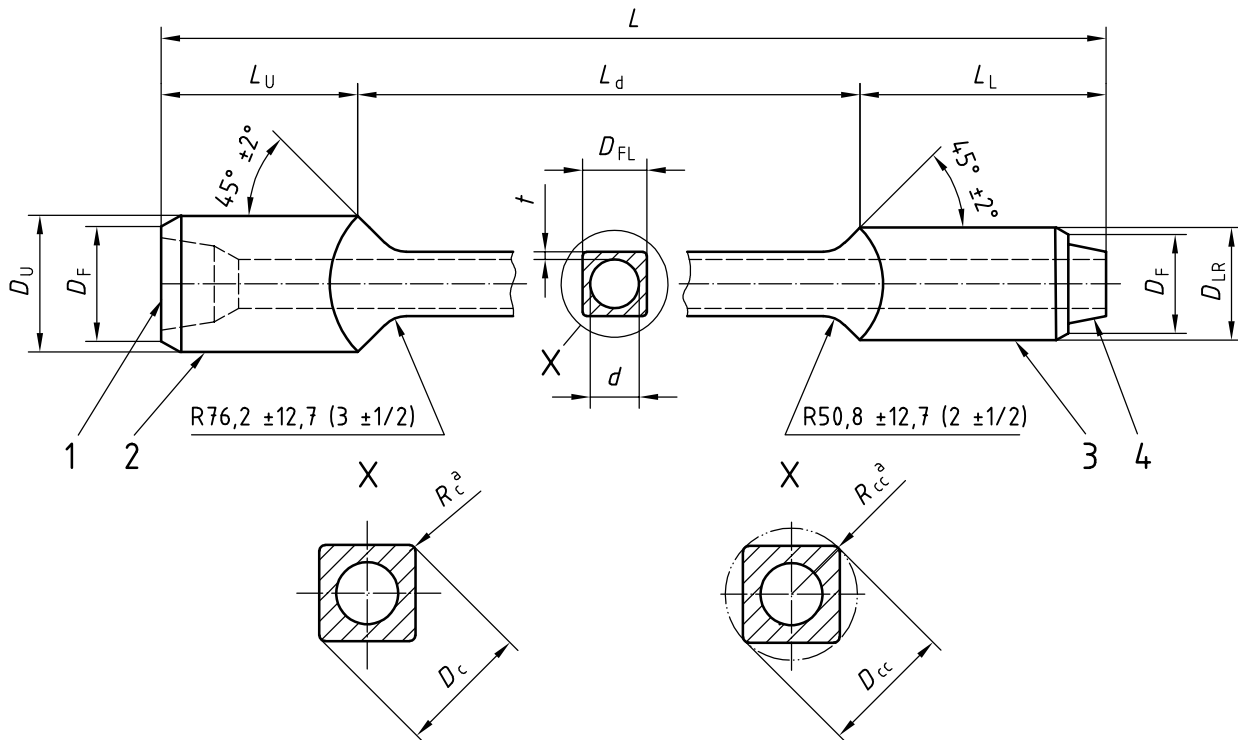

Key

- 1 LH rotary box connection
- 2 upper upset
- 3 lower upset
- 4 RH rotary pin connection

^a Corner configuration R_C or R_{CC} shall be at the manufacturer's option.

Figure 2 — Square kelly

Table 5 — Square kelly end upsets and connections

Dimensions in millimetres

1	2	3	4	5	6	7	8	9	10	11
Kelly size ^b	Upper box connection ^a					Lower pin connection ^a				
	Label ^c	Outside diameter	Bevel diameter	Upset length	Label ^c	Outside diameter	Inside diameter	Bevel diameter	Upset length	
		D_U ± 0,8	D_F ± 0,4	L_U +63,5 0		D_{LR} ± 0,8	d +1,6 0	D_F ± 0,4	L_L +63,5 0	
63,5	Standard	6 5/8 REG	196,8	186,1	406,4	NC26	85,7	31,8	83,0	508,0
	Optional	4 1/2 REG	146,0	134,5	406,4	NC26	85,7	31,8	83,0	508,0
76,2	Standard	6 5/8 REG	196,8	186,1	406,4	NC31	104,8	44,4	100,4	508,0
	Optional	4 1/2 REG	146,0	134,5	406,4	NC31	104,8	44,4	100,4	508,0
88,9	Standard	6 5/8 REG	196,8	186,1	406,4	NC38	120,6	57,2	116,3	508,0
	Optional	4 1/2 REG	146,0	134,5	406,4	NC38	120,6	57,2	116,3	508,0
108,0	Standard	6 5/8 REG	196,8	186,1	406,4	NC46	158,8	71,4	145,2	508,0
	Standard	6 5/8 REG	196,8	186,1	406,4	NC50	161,9	71,4	154,0	508,0
	Optional	4 1/2 REG	146,0	134,5	406,4	NC46	158,8	71,4	145,2	508,0
	Optional	4 1/2 REG	146,0	134,5	406,4	NC50	161,9	71,4	154,0	508,0
133,4	Standard	6 5/8 REG	196,8	186,1	406,4	5 1/2 FH	177,8	82,6	170,6	508,0
	Standard	6 5/8 REG	196,8	186,1	406,4	NC56	177,8	82,6	171,0	508,0

NOTE See Figure 2 for configuration of end upsets.

^a See 6.3 for requirements of rotary shouldered connections.

^b Size of square kellys is the same as the dimension D_{FL} across flats (distance between opposite faces) as given in Column 6 of Table 4.

^c Labels are for information and assistance in ordering.

Table 6 — Hexagonal kelly drive section

1	2	3	4	5	6	7	8	9	10	11
Kelly size ^a	Length drive section		Length overall		Across flats	Across corners	Across corners	Radius	Radius	Wall thickness eccentric bore
	m		m							
	Standard	Optional	Standard	Optional	mm	mm	mm	mm	mm	mm
L_D	L_D	L	L	D_{FL}	D_C	D_{CC}	R_C	R_{CC}	t	
+0,152 -0,127	+0,152 -0,127	+0,152 0	+0,152 0	+0,8 0	± 0,8	0 -0,4	± 0,8	Ref only	min.	
76,2	11,28	—	12,19	—	76,2	85,7	85,72	6,4	42,9	12,06
88,9	11,28	—	12,19	—	88,9	100,8	100,00	6,4	50,0	13,34
108,0	11,28	15,54	12,19	16,46	108,0	122,2	121,44	7,9	60,7	15,88
133,4	11,28	15,54	12,19	16,46	133,3	151,6	149,86	9,5	75,0	15,88
152,4	11,28	15,54	12,19	16,46	152,4	173,0	173,03	9,5	86,5	15,88

NOTE See Figure 3 for configuration of hexagonal drive section.

^a Size of hexagonal kellys is the same as the dimension D_{FL} across the flats (distance between opposite faces) as given in Column 6.

Dimensions in millimetres (inches)

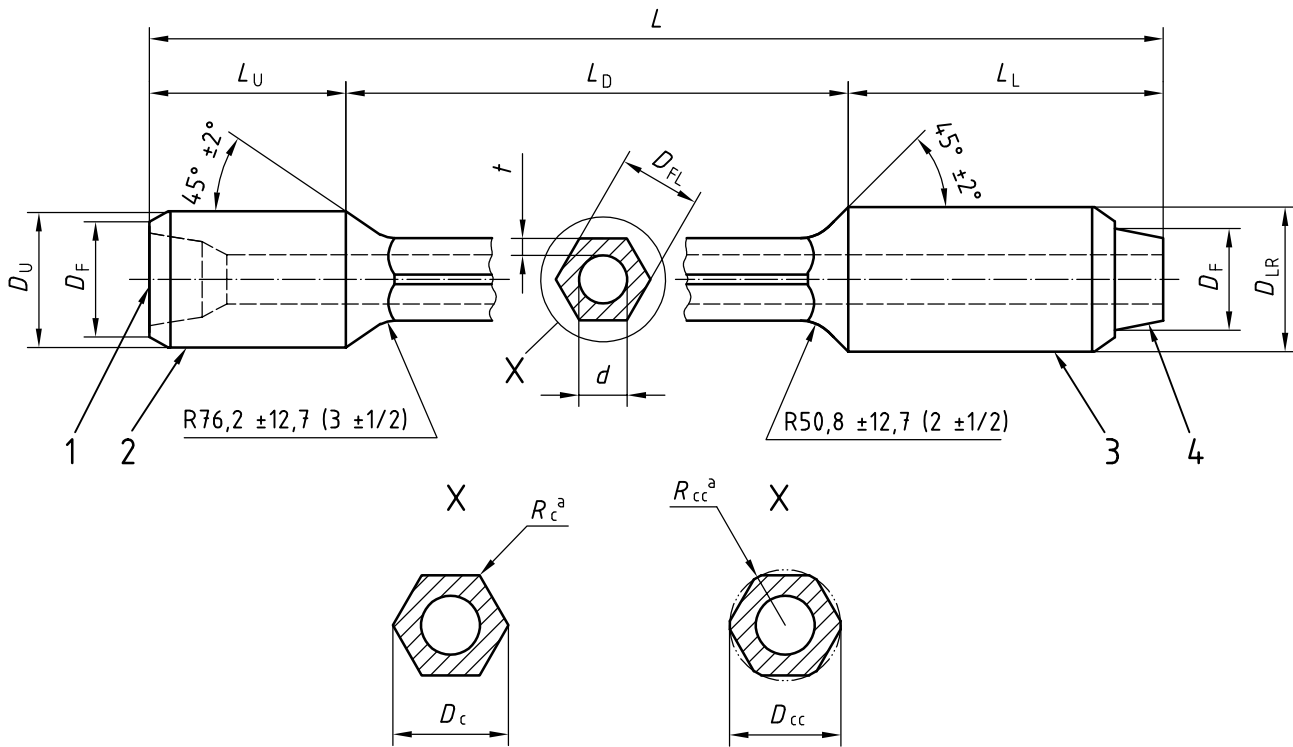

Key

- 1 LH rotary box connection
- 2 upper upset
- 3 lower upset
- 4 RH rotary pin connection

^a Corner configuration R_C or R_{CC} shall be at the manufacturer's option.

Figure 3 — Hexagonal kelly

Table 7 — Hexagonal kelly end upsets and connections

Dimensions in millimetres

1	2	3	4	5	6	7	8	9	10	11
Kelly size ^b	Upper box connection ^a					Lower pin connection ^a				
	Label ^c	Outside diameter	Bevel diameter	Upset length	Label ^c	Outside diameter	Inside diameter	Bevel diameter	Upset length	
		D_U ± 0,8	D_F ± 0,4	L_U $^{+63,5}_0$		D_{LR} ± 0,8	d $^{+16}_0$	D_F ± 0,4	L_L $^{+63,5}_0$	
76,2	Standard	6 5/8 Reg	196,9	186,1	406,4	NC 26	85,7	31,8	82,9	508,0
	Optional	4 1/2 Reg	146,0	134,5	406,4	NC 26	85,7	31,8	82,9	508,0
88,9	Standard	6 5/8 Reg	196,9	186,1	406,4	NC31	104,8	44,4	100,4	508,0
	Optional	4 1/2 Reg	146,0	134,5	406,4	NC31	104,8	44,4	100,4	508,0
108,0	Standard	6 5/8 Reg	196,9	186,1	406,4	NC38	120,6	57,2	116,3	508,0
	Optional	4 1/2 Reg	146,0	134,5	406,4	NC38	120,6	57,2	116,3	508,0
133,4	Standard	6 5/8 Reg	196,9	186,1	406,4	NC46	158,8	76,2 ^d	145,2	508,0
	Standard	6 5/8 Reg	196,9	186,1	406,4	NC50	161,9	82,6 ^d	154,0	508,0
152,4	Standard	6 5/8 Reg	196,9	186,1	406,4	5 1/2 FH	177,8	88,9	170,6	508,0
	Standard	6 5/8 Reg	196,9	186,1	406,4	NC56	177,8	88,9	171,0	508,0

NOTE See Figure 3 for configuration of end upsets.

a See 6.3 for requirements of rotary shouldered connections.

b Size of hexagonal kellys is the same as dimensions D_{FL} across flats (distance between opposite faces) given in column 6 of Table 6.

c Labels are for information and assistance in ordering.

d For 133,3 hexagonal kellys, a bore of 71,4 mm shall be optional.

Table 8 — Kelly sleeve gauge

Dimensions in millimetres

Kelly size	Minimum length of gauge L_G	Distance across flats		Maximum fillet radius	
		Square	Hexagonal	Square	Hexagonal
		D_{FL} ^{a, b}	D_{FL} ^{a, b}	R_S	R_H
63,5	254	65,89	—	6	—
76,2	254	78,59	77,11	8	5
88,9	254	91,29	89,81	11	5
108,0	305	111,12	108,86	11	6
133,4	305	136,52	134,26	14	8
152,4	305	—	153,31	—	8

NOTE See Figure 4 for configuration of kelly sleeve gauge.

a Tolerances on D_{FL} , all sizes: from $^{+0,13}_0$ mm.

b Tolerances on nominal included angles between flats: ± 0,5°.

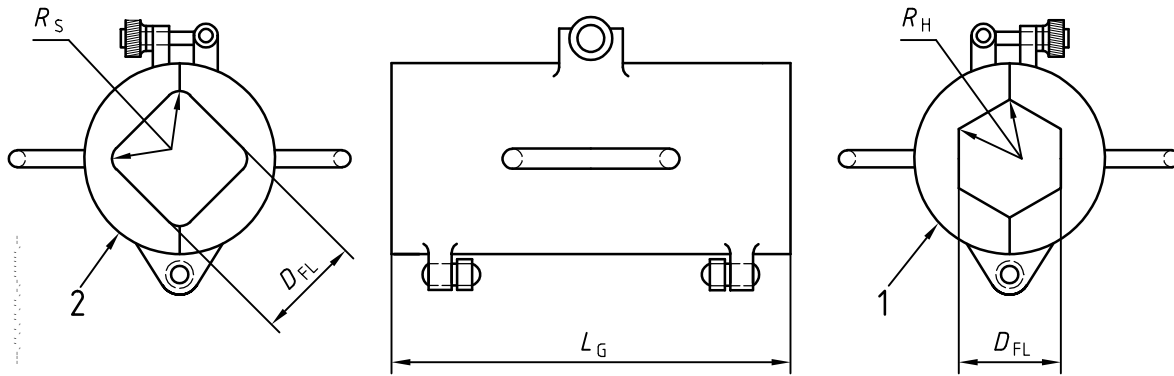

Key

- 1 hexagonal sleeve gauge
- 2 square sleeve gauge

Figure 4 — Sleeve gauge for kellys (see Table 8)

Table 9 — Mechanical properties and tests — New kellys (all sizes)

Lower upset OD mm	Lower upset yield strength MPa min.	Lower upset tensile strength MPa min.	Elongation % min.	Brinell hardness HBW min.
85,7 to 174,6	758	965	13	285
177,8	689	931	13	285

7 Drill-stem subs

7.1 Class and type

Drill-stem subs shall be furnished in the classes and types shown in Table 10 and Figures 5 and 6.

7.2 Dimensions for types A and B

7.2.1 Connections, bevel diameters and outside diameters

The connection sizes and styles shall conform to the applicable sizes and styles, specified in Table 5 and Table 7 when connecting to kellys, in Table 14 and Table 19 when connecting to drill collars, in Table 23, Table 24 and Table 26 when connecting to bits and to API Spec 7 when connecting to drill-pipe tool joints.

The connections shall conform to the dimensional and gauging requirements of API Spec 7.

Bevel diameter dimensions and outside diameters shall conform to the applicable dimensions and tolerances specified in Table 5 and Table 7 when connecting to kellys, in Table 14 and Table 19 when connecting to drill collars, in Table 23, Table 24 and Table 26 when connecting to bits, and to API Spec 7 when connecting to drill-pipe tool joints.

7.2.2 Inside diameters

The inside diameters of the two connecting members shall be determined. The inside diameter (and applicable tolerances) of the type A or type B sub shall be equal to the smaller of the two inside diameters of these members.

7.2.3 Inside bevel diameter

The inside bevel diameter of the pin shall be equal to $3,2 \begin{smallmatrix} 1,6 \\ 0 \end{smallmatrix}$ mm ($1/8 \begin{smallmatrix} 1/16 \\ 0 \end{smallmatrix}$ in) larger than the inside diameter specified for the corresponding connecting member.

7.2.4 Length

Lengths and tolerances for types A and B drill-stem subs shall be as shown in Figure 5.

7.2.5 Float valve recess for bit subs

Float valve recesses are optional. If float valve recesses are specified, bit subs shall be bored to the dimensions shown in Table 13 and Figure 7 for the applicable assembly.

7.3 Dimensions for type C (swivel subs)

7.3.1 Connections, bevel diameters and outside diameters

The connections on the swivel sub shall be pin up and pin down (both left-hand). The lower-pin connection size, style shall conform to the applicable sizes and styles specified in Table 5 or Table 7 for the upper kelly box connection. The upper connection shall be the same size and style as the swivel stem box connection, i.e. 4 1/2, 6 5/8, or 7 5/8 API Reg.

The connections shall conform to the dimensional and gauging requirements of API Spec 7.

Bevel diameter dimensions for the pin-down connection shall conform to the applicable dimensions and tolerances specified in Table 5 or Table 7 for the upper kelly box connections. The bevel diameter for the upper pin connection shall match the bevel diameter of the swivel stem box connection, i.e. 4 1/2, 6 5/8 or 7 5/8 API Reg.

The outside diameter and tolerances of the sub shall conform to the larger of either the kelly upper box connection or the swivel stem box connection outside diameter.

7.3.2 Inside diameter

The maximum inside diameter shall be the largest diameter allowed for the upper kelly connection specified in Table 5 or Table 7. In the case of step-bored subs in which the bore through the upper pin is larger than the bore through the lower pin, the upper pin bore shall not be so large as to cause the upper pin to have lower tensile strength or torsional strength than the lower pin as calculated in accordance with API RP 7G.

7.3.3 Inside bevel diameter

The inside bevel diameter shall be $6 \begin{smallmatrix} +2 \\ -1 \end{smallmatrix}$ mm ($1/4 \pm 1/16$ in) larger than the bore.

7.3.4 Length

The minimum tong space allowable shall be 200 mm (8 in).

7.4 Type D (lift sub) dimensions

7.4.1 Diameter of lift recess and diameter of lift shoulder

The diameters of the lift recess and the lift shoulder shall conform to the dimensions of Table 12.

7.4.2 Connections, bevel diameters and outside diameter

The connection sizes and styles shall conform to the applicable sizes and styles specified in Table 14.

The connections shall conform to the dimensional and gauging requirements of API Spec 7.

Bevel diameters and outside diameter shall conform to the applicable dimensions and tolerances specified in Table 14.

7.4.3 Inside diameter

The maximum inside diameter shall be the largest diameter allowed for the applicable size and style of connection specified in Table 14 and Table 20.

7.4.4 Length

Lengths and tolerances for type D drill-stem subs shall be as shown in Figure 6.

7.5 Mechanical properties

7.5.1 Tensile requirements

The tensile properties of type A and type C subs and the larger-diameter section of type B subs shall conform to the tensile requirements of drill collars as specified in 7.2.

On type B subs with turned ODs, the original test results may not be indicative of the tensile properties of the reduced section. On type B subs, destructive determination of tensile properties by testing is not necessary or practical on the reduced-diameter section.

7.5.2 Hardness requirements

A Brinell hardness reading as specified in Table 11 shall be *prima facie* evidence of satisfactory mechanical properties in the section of reduced diameter. The surface hardness of the as-manufactured reduced-diameter section of type B subs shall be measured in accordance with ISO 6506-1.

NOTE For the purposes of this provision, ASTM A 370 is equivalent to ISO 6506-1.

7.5.3 Impact strength requirements

7.5.3.1 General

Charpy V-notch impact tests shall be conducted on specimens conforming to the requirements of ISO 148 and shall be conducted at a temperature of $21\text{ °C} \pm 3\text{ °C}$ ($70\text{ °F} \pm 5\text{ °F}$). Tests conducted at lower temperatures that meet the requirements stated in 7.5.3.4 are acceptable.

NOTE For the purposes of this provision, ASTM A 370 and ASTM E 23 are equivalent to ISO 148.

7.5.3.2 Specimens

One set of 3 specimens per heat per heat-treatment lot shall be tested.

Specimens shall be taken from the lower upset at 25,4 mm (1 in) below the surface or at mid-wall, whichever is closer to the outer surface.

The specimens shall be longitudinally oriented and radially notched.

7.5.3.3 Specimen size

Specimens of full size (10 mm × 10 mm) shall be used except where there is insufficient material, in which case the next smaller standard subsize specimen obtainable shall be used.

If it is necessary to use subsize test specimens, the acceptance criteria shall be multiplied by the appropriate adjustment factor listed in Table 2. Subsize test specimens of less than 5 mm are not permitted.

7.5.3.4 Acceptance criteria

The average impact strength of the three specimens shall be 54 J (40 ft-lbs) or greater, with no single value less than 47 J (35 ft-lbs).

7.6 Non-destructive examination

All bars or tubes used to manufacture drill-stem subs shall be examined for both surface and internal defects in accordance with Clause 10 of this part of ISO 10424. Materials containing defects shall not be used to manufacture drill-stem subs.

7.7 Connection stress-relief features

Stress-relief features are optional on type A and B subs and mandatory on type C subs which are 4 1/2 API Reg and larger. Stress-relief features provide no apparent benefit to type D subs and therefore are not recommended.

Dimensions and tolerances of connection stress-relief features shall conform to the dimensions and tolerances listed in API Spec 7, and are applicable to connections on type A, B, and C subs shown in Table 10.

7.8 Cold working of thread roots

Cold working of thread roots is optional on type A, B and C subs. Cold working of thread roots provides no apparent benefit to type D subs and therefore is not recommended. See 8.1.7.3 for details.

7.9 Gall-resistant treatment of threads and sealing shoulders

A gall-resistant treatment of zinc or manganese phosphate shall be applied to the threads and sealing shoulders of both the upper and lower connections. Application of the treatment shall be after completion of all gauging. The treatment type shall be at the discretion of the manufacturer.

7.10 Marking

Subs manufactured in conformance with this part of ISO 10424 shall be marked with the following information:

- a) the manufacturer's name or identification mark;
- b) "ISO 10424-1";
- c) the inside diameter;
- d) the size and style of the connection at each end.

ISO 10424-1:2004(E)

The marking shall be die-stamped on a marking recess located on the outside diameter of the sub. The marking identifying the size and style of the connection shall be placed on that end of the recess closest to the connection to which it applies. The marking recess location is shown in Figure 5.

EXAMPLE 1 A sub with 4 1/2 Reg LH box connection on each end and with a 57,2 mm (2 1/4 in) inside diameter, manufactured by A B Company, shall be marked as follows:

A B Co. (or mark)		ISO 10424-1
4 1/2 REG LH	57,2 (2 1/4)	4 1/2 REG LH

EXAMPLE 2 A sub with NC 31 pin connection on one end and NC 46 box connection on the other end and with a 50,8 mm (2 in) inside diameter, manufactured by A B Company, shall be marked as follows:

A B Co (or mark)		ISO 10424-1
NC 31	50,8 (2)	NC 46

Table 10 — Drill stem subs

1	2	3	4
Type	Class	Upper connection to assemble with	Lower connection to assemble with
A or B	kelly sub	kelly	tool joint
A or B	tool joint sub	tool joint	tool joint
A or B	crossover sub	tool joint	drill collar
A or B	drill collar sub	drill collar	drill collar
A or B	bit sub	drill collar	bit
C	swivel sub	swivel stem	kelly
D	lift sub	elevator	drill collar

Dimensions in millimetres (inches)

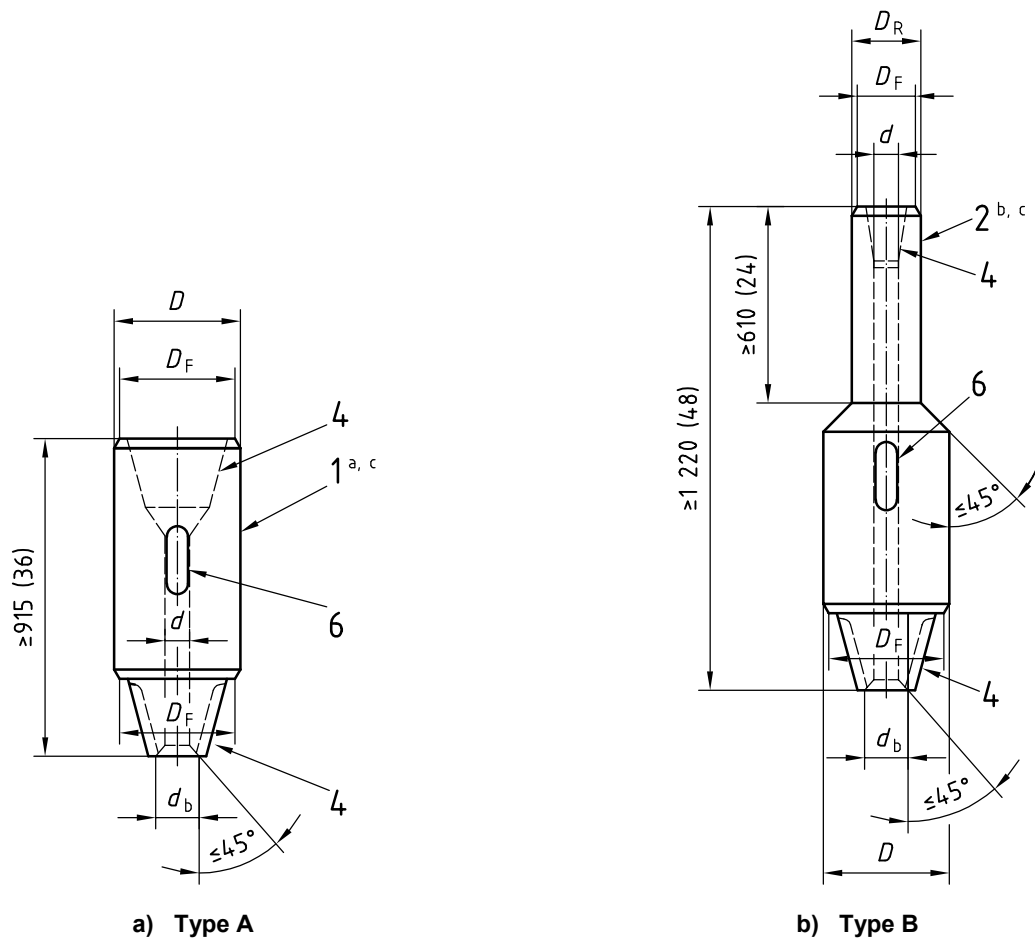

a) Type A

b) Type B

c) Type C

Key

- 1 type A rotary sub
- 2 type B rotary sub
- 3 type C rotary sub
- 4 rotary pin or box connection
- 5 LH pin connection
- 6 marking recess location

a If type A is a double-box or double-pin sub, the overall length shall be ≥ 915 mm (36 in).

b If type B is a double-box or double-pin sub, the overall length shall be $\geq 1\,220$ mm (48 in).

c See Table 10 for function of sub.

Figure 5 — Drill-stem subs (types A, B and C)

Table 11 — Minimum surface hardness of dimension D_R of type B drill-stem subs

1	2
Large OD D mm	Surface Brinell hardness of reduced diameter section D_R HBW min.
79,4 through 174,6	285
177,8 through 254,0	277

Table 12 — Dimensions for lift-sub upper lift diameters

Dimensions in millimetres

Elevator recess diameter	Diameter of lift shoulder (tapered or square)	Overall length	Top length	Elevator recess length	Bottom length
D_p	D_L	L_1	L_2	L_3	L_4
$\pm 0,8$	$\begin{matrix} +3,2 \\ 0 \end{matrix}$	$\begin{matrix} +76 \\ -25 \end{matrix}$	± 3	Ref.	± 12
60,3	85,7	915	102	457	356
73,0	104,8	915	102	457	356
88,9	120,6	915	102	457	356
101,6	152,4	915	102	457	356
114,3	158,8	915	102	457	356
127,0	165,1	915	102	457	356
139,7	177,8	915	102	457	356
168,3	203,2	915	102	457	356

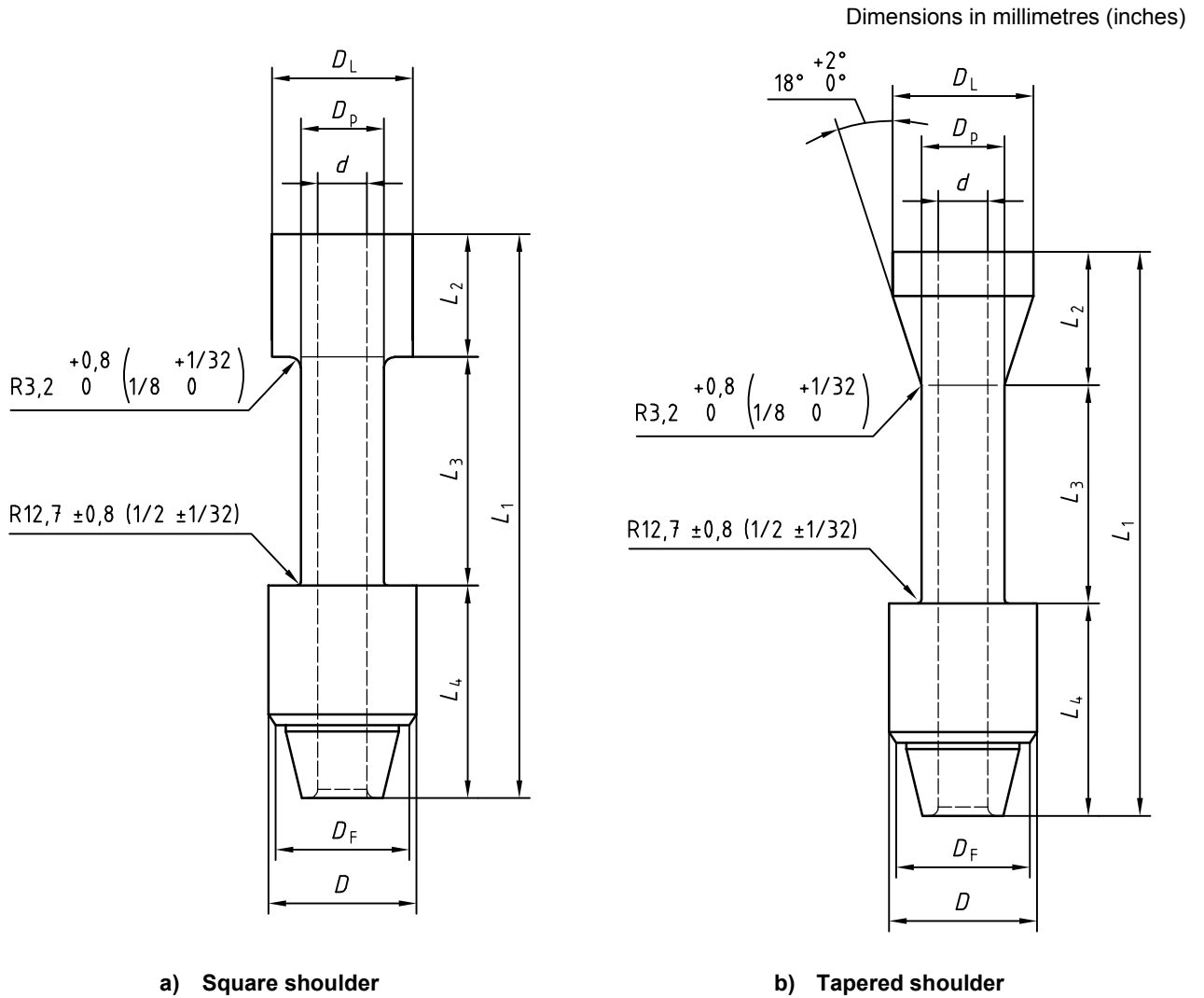

NOTE See Table 12 for dimensions.

Figure 6 — Lift subs (type D)

Table 13 — Float valve recess in bit subs

Dimension in millimetres

Diameter of valve assembly <i>D</i> Ref.	Diameter of float recess <i>D_{FR}</i> ^a +0,4 0	Length of valve assembly <i>L_{FV}</i> (Reference)	API REG bit box			Other popular connections	
			Label ^b	<i>L_R</i> ± 1,6	<i>D_{BP}</i> +0,8 0	Label ^b	<i>L_R</i> ± 1,6
42,1	42,9	149,2	2 3/8 Reg	231,8	33,3	NC23	231,8
48,4	49,2	158,8	2 7/8 Reg	254,0	38,1	NC26	241,3
61,1	61,9	165,1	3 1/2 Reg	266,7	48,4	NC31	260,4
71,4	72,2	254,0	—	—	—	3 1/2 FH	355,6
79,4	80,2	254,0	—	—	—	NC38	362,0
88,1	88,9	211,1	4 1/2 Reg	325,4	74,6	NC44	331,8
92,9	93,7	304,8	—	—	—	NC46	425,4
98,4	99,2	247,6	5 1/2 Reg	374,6	85,7	NC50	368,3
121,4	122,2	298,4	6 5/8 Reg	431,8	108,7	5 1/2 IF	431,8
121,4	122,2	298,4	7 5/8 Reg	438,2	108,7	5 1/2 FH	431,8
121,4	122,2	298,4	8 5/8 Reg	441,3	108,7	NC61	444,5
144,5	145,2	371,5	8 5/8 Reg	514,4	131,8	6 5/8 IF	504,8

^a Diameter DFR equals D + 0,8 mm.

^b Labels are for information and assistance in ordering.

Dimensions in millimetres (inches)

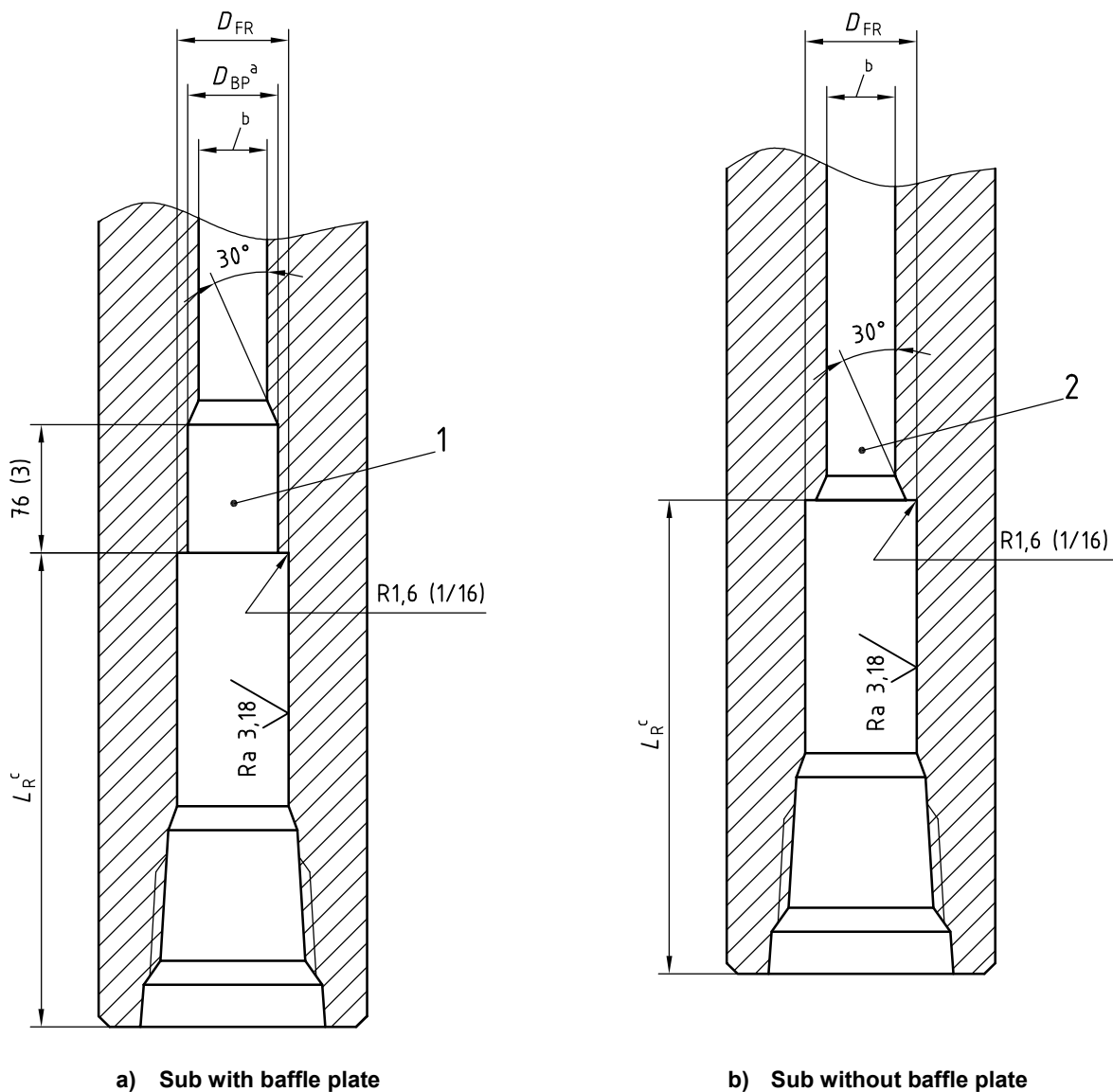

Key

- 1 with baffle plate recess
- 2 without baffle plate recess

a If diameter D_{BP} is the same as or smaller than bore, then disregard.

b The ID of drill collar or sub and the ID of the bit pin shall be small enough to hold valve assembly.

c $L_R = L_{FV} + \text{length of rotary shouldered pin} + 6,4 \text{ mm (1/4 in.)}$.

Figure 7 — Float valve recess in bit subs (see Table 13)

8 Drill collars

8.1 General

8.1.1 Size

Standard steel drill collars shall be furnished in the sizes and dimensions shown in Table 14 and illustrated in Figure 8.

Non-magnetic drill collars shall be furnished in the sizes and dimensions shown in Table 14 or Table 20 with the exceptions noted in 8.3.1.

8.1.2 Outside diameter tolerances

The outside diameter shall comply with the tolerances of Table 15.

8.1.3 Bores

All drill collar bores shall be gauged with a drift mandrel 3,05 m (10 ft) long minimum. The drift mandrel shall have a minimum diameter equal to the bore diameter, d (see Table 14), minus 3,2 mm (1/8 in).

8.1.4 Surface finish

8.1.4.1 Standard steel

The minimum external surface finish shall be hot-rolled and mill-finished. Workmanship shall comply with ASTM A 434. Surface imperfection removal shall comply with Table 16.

8.1.4.2 Non-magnetic

Non-magnetic bars and tubes shall have the outside surface machine-turned or ground to 100 % clean-up. Surface imperfection removal shall comply with Table 16.

8.1.5 Straightness

The external surface of drill collars shall not deviate from a straight line extending from end to end of the drill collar, when the straight line is placed adjacent to the surface, by more than 0,5 mm/m (1/160 in/ft) of drill collar length.

EXAMPLE On a drill collar of length 9,14 m (30 ft), the maximum permitted deviation from a straight line is $9,14 \times 0,5 = 4,6$ mm ($30 \times 1/160 = 3/16$ in).

8.1.6 Non-destructive examination

Each bar or tube used to manufacture drill collars shall be examined for both surface and internal defects in accordance with Clause 10 of this part of ISO 10424.

8.1.7 Connections

8.1.7.1 Size and type

8.1.7.1.1 Standard steel drill collars

Standard steel drill collars shall be furnished with box-up and pin-down connections in the sizes and styles stipulated for the OD and ID combinations listed in Table 14. The connections shall conform to the dimensional and gauging requirements of API Spec 7.

8.1.7.1.2 Non-magnetic drill collars

Non-magnetic drill collars may be produced as string-type collars or as bottom-hole-type collars.

String-type non-magnetic drill collars shall be furnished with box-up and pin-down connections in the sizes and styles stipulated for the OD and ID combinations listed in Table 14 or Table 20. The connections shall conform to the dimensional and gauging requirements of API Spec 7.

Bottom-hole non-magnetic drill collars shall be furnished with upper box connections in the sizes and styles stipulated for the OD and ID combinations listed in Table 14 or Table 20 and with lower box connections as listed in Table 19. Both the upper and lower connections shall conform to the dimensional and gauging requirements of API Spec 7.

8.1.7.2 Connection stress-relief features

Stress-relief features are optional. If stress-relief features are specified, they shall conform to the dimensions specified in API Spec 7.

The surfaces of stress-relief features shall be free of stress risers such as tool marks and steel stencil impressions.

Laboratory fatigue tests and tests under actual service conditions have demonstrated the beneficial effects of stress-relief contours at the pin shoulder and at the base of the box thread. It is recommended that, where fatigue failures at points of high stress are a problem, stress-relief features be provided.

The boreback design is the recommended relief feature for box connections. However, the box relief groove design has also been shown to provide beneficial effects. It may be used as an alternative to the boreback design.

Stress-relief features cause a slight reduction in the tensile strength of the pin and the section modulus of the connection. However, under most conditions this reduction in cross-sectional area is more than offset by the reduction in fatigue failures. If unusually high tensile loads are expected, calculations of the effect should be made.

8.1.7.3 Cold working of thread roots

Cold working of thread roots is optional. The method of cold working is at the discretion of the manufacturer.

As with stress-relief features, laboratory fatigue tests and tests under actual service conditions have demonstrated the beneficial effects of cold working the thread roots of rotary shouldered connections. It is recommended that, where fatigue failures at points of high stress are a problem, cold working be provided.

If threads are cold-worked, they shall be gauged to API Spec 7 requirements before cold working.

Gauge standoff will change after cold working of threads, and can result in connections that do not fall within the specified ISO gauge standoff if gauged after cold working. This does not affect the interchangeability of connections and improves connection performance. It is therefore permissible for a connection to be marked as complying with the requirements of API Spec 7 if it meets the standoff requirements before cold working. In such event, the connection shall also be stamped with a circle enclosing "CW" to indicate cold working after gauging. The mark shall be located on the connection as follows:

- a) pin connection: at the small end of the pin;
- b) box connection: in the box counterbore.

8.1.7.4 Low torque feature

If the 8 5/8 Reg connection is machined on drill collars with OD larger than 266,7 mm (10 1/2 in), the faces and box counterbores shall conform to the dimensions for low torque feature as specified in API Spec 7.

8.1.8 Slip and elevator grooves

Slip and/or elevator grooves are optional. If they are specified, they shall conform to the dimensions shown in Table 21 and Figure 9. It is permissible to specify only the slip groove or only the elevator groove, rather than both. Location and dimensions of single features shall be in accordance with Figure 9.

8.1.9 Gall-resistant treatment of threads and sealing shoulders

A gall-resistant treatment of zinc or manganese phosphate shall be applied to the threads and sealing shoulders of all end connections of drill collars manufactured from standard steel. Application of the treatment shall be after completion of all gauging. The treatment type shall be at the discretion of the manufacturer.

Gall-resistant treatments are not readily available for non-magnetic drill collars, therefore are not required.

8.2 Standard steel drill collars

8.2.1 Mechanical properties

8.2.1.1 Tensile requirements

The tensile properties of standard steel drill collars, as manufactured, shall comply with the requirements of Table 17.

These properties shall be verified by performing a tensile test on one specimen per heat per heat-treatment lot.

Tensile properties shall be determined by tests on cylindrical specimens conforming to the requirements of ISO 6892, 0,2 % offset method.

NOTE For the purposes of this provision, ASTM A 370 is equivalent to ISO 6892.

The tensile specimen may be taken from either end of the bar or tube. The specimen shall be machined so that the centre point of the gauge area is located a minimum of 100 mm (4 in) from the end of the bar or tube. The tensile specimen shall be oriented in the longitudinal direction, with the centreline of the specimen located 25,4 mm (1 in) from the outside surface or mid-wall, whichever is closer to the outside surface.

8.2.1.2 Hardness requirements

In addition, a hardness test shall be performed on each drill collar as *prima facie* evidence of conformation. The hardness test shall be made on the OD of the drill collar (Brinell hardness in accordance with ISO 6506-1 is preferred although Rockwell C hardness is an acceptable alternative). The hardness number shall conform to the requirements of Table 17.

NOTE For the purposes of this provision, ASTM A 370 is equivalent to ISO 6506-1.

8.2.1.3 Impact strength requirements

8.2.1.3.1 General

Charpy V-notch impact tests shall be conducted on specimens conforming to the requirements of ISO 148 and shall be conducted at a temperature of 21 °C ± 3°C (70 °F ± 5 °F). Tests conducted at lower temperatures that meet the requirements stated in 8.2.1.3.4 are acceptable.

NOTE For the purposes of this provision, ASTM A 370 and ASTM E 23 are equivalent to ISO 148.

8.2.1.3.2 Specimens

One set of 3 specimens per heat per heat-treatment lot shall be tested.

Specimens shall be taken at 25,4 mm (1 in) below the surface or at mid-wall, whichever is closer to the as-heat-treated outer surface.

The specimens shall be longitudinally oriented and radially notched.

8.2.1.3.3 Specimen size

Full size (10 mm × 10 mm) shall be used except where there is insufficient material, in which case the next smaller standard subsize specimen obtainable shall be used.

If it is necessary to use subsize test specimens, the acceptance criteria shall be multiplied by the appropriate adjustment factor listed in Table 2. Subsize test specimens of less than 5 mm are not permitted.

8.2.1.3.4 Acceptance criteria

The average impact strength of the three specimens shall be 54 J (40 ft-lbs) or greater, with no single value less than 47 J (35 ft-lbs).

8.2.2 Marking

Standard steel drill collars conforming to this part of ISO 10424 shall be die-stamped on the drill collar OD with the following information:

- a) the manufacturer's name or identifying mark;
- b) outside diameter;
- c) bore;
- d) connection designation;
- e) "ISO 10424-1".

NOTE The drill collar number consists of two parts separated by a hyphen. The first part is the connection number in the NC style. The second part, consisting of 2 (or 3) digits, indicates the drill collar outside diameter in units and tenths of inches. Drill collars with 209,6 mm, 241,3 mm and 279,4 mm outside diameters are shown with 6 5/8, 7 5/8 and 8 5/8 REG connections, since there are no NC connections in the recommended range of bending-strength ratios.

EXAMPLE 1 A drill collar of diameter 158,6 mm (6 1/4 in) with 71,4 mm (2 13/16 in) bore and NC46 connections, manufactured by A B Company, shall be stamped:

A B Co. (or mark) NC46-62 71,4 ISO 10424-1

EXAMPLE 2 A drill collar of diameter 209,6 mm (8 1/4 in) with 71,4 mm (2 13/16 in) bore and 6 5/8 Reg connections, manufactured by A B Company, shall be stamped:

A B Co. (or mark) 209,6 71,4 6 5/8 REG ISO 10424-1

8.3 Non-magnetic drill collars

8.3.1 Dimensional requirements

8.3.1.1 Length tolerance

The length tolerance for non-magnetic drill collars shall be $^{+152,4}_0$ mm ($^{+6}_0$ in).

8.3.1.2 Bore eccentricity

The maximum bore eccentricity shall be 2,39 mm (0.094 in) at the collar ends. The centre eccentricity shall not exceed 6,35 mm (0.250 in).

NOTE The purpose of the eccentricity specification in the centre of a non-magnetic collar is to ensure reasonably accurate alignment of a survey instrument with the drill collar axis. Eccentricity in the centre does not have a significant effect on the torsional or tensile strength of the collar.

8.3.2 Mechanical properties

8.3.2.1 Tensile requirements

The tensile properties of non-magnetic drill collars shall comply with the requirements of Table 18.

These properties shall be verified by performing a tensile test on one specimen (with properties representative of the end product) for each bar size per heat per heat-treatment lot.

Tensile properties shall be determined by tests on cylindrical specimens conforming to the requirements of ISO 6892, 0,2 % offset method.

NOTE For the purposes of this provision, ASTM A 370 is equivalent to ISO 6892.

The tensile specimen may be taken from either end of the bar or tube. The specimen shall be machined so that the centre point of the gauge area is located a minimum of 100 mm (4 in) from the end of the bar or tube. The tensile specimen shall be oriented in the longitudinal direction with the centreline of the specimen located 25,4 mm (1 in) from the outside surface or mid-wall, whichever is closer to the outside surface.

8.3.2.2 Hardness requirements

In addition, a hardness test shall be performed on each drill collar for information only. Correlation between hardness and material strength is not reliable. The hardness test shall be made on the outside diameter of the drill collar (Brinell hardness in accordance with ISO 6506-1 is preferred although Rockwell C hardness is an acceptable alternative).

NOTE For the purposes of this provision, ASTM A 370 is equivalent to ISO 6506-1.

8.3.3 Magnetic properties

8.3.3.1 Measurements of relative magnetic permeability

Drill collars shall have a relative magnetic permeability less than 1,010. Each certification of relative magnetic permeability shall identify the test method. The manufacturer shall also state whether tests have been performed on individual collars or on a sample that qualifies a product lot. One lot is defined as all material with the same form from the same heat processed at one time through all steps of manufacture.

8.3.3.2 Field gradient measurement

The magnetic field in the bore of new drill collars shall exhibit deviation from a uniform magnetic field not exceeding $\pm 0,05 \mu\text{T}$. This shall be measured with a magnetoscope and differential field probe having its magnetometers oriented in the axial direction of the collar. A strip-chart record showing differential field along the entire bore of the collar shall be part of the certification of each collar.

8.3.4 Corrosion resistance requirements (for austenitic steel collars of 12 % chromium or more)

Austenitic stainless steel collars are subject to cracking due to the joint action of tensile stress and certain specific corrosive agents. This phenomenon is called stress-corrosion cracking.

Resistance to intergranular corrosion shall be demonstrated by subjecting material from each collar to the corrosion test specified in ASTM A 262 Practice E. At the discretion of each supplier, the test specimen may have an axial orientation, in which case it shall be taken from within 12,7 mm (0.5 in) of the bore surface, or it may have a tangential orientation, in which case its midpoint shall be within 12,7 mm (0.5 in) of the bore surface.

Under some environmental circumstances, steels may be subject to transgranular stress-corrosion cracking. Tendencies vary with different compositions, but additional resistance may be provided by surface treatments that lead to compressive residual stress.

8.3.5 Marking

Non-magnetic drill collars conforming to this part of ISO 10424 shall be die-stamped with the following information:

- a) the manufacturer's name or identifying mark;
- b) outside diameter;
- c) bore;
- d) non-magnetic identification (non-magnetic drill collar NMDC);
- e) connection designation;
- f) "ISO 10424-1".

NOTE The drill collar number consists of two parts separated by a hyphen. The first part is the connection number in the NC style. The second part, consisting of 2 (or 3) digits, indicates the drill collar outside diameter in units and tenths of inches. Drill collars with 209,6 mm, 241,3 mm and 279,4 mm outside diameters are shown with 6 5/8, 7 5/8 and 8 5/8 REG connections, since there are no NC connections in the recommended range of bending-strength ratios.

The example below illustrates these marking requirements. Locations of the markings and the application of additional markings shall be specified by the manufacturer.

EXAMPLE A 209,6 mm (8 1/4 in) collar, with 71,4 mm (2 13/16 in) bore, manufactured by A B Company, shall be stamped:

A B Co. (or mark) 209,6 71,4 NMDC 6 5/8 REG ISO 10424-1

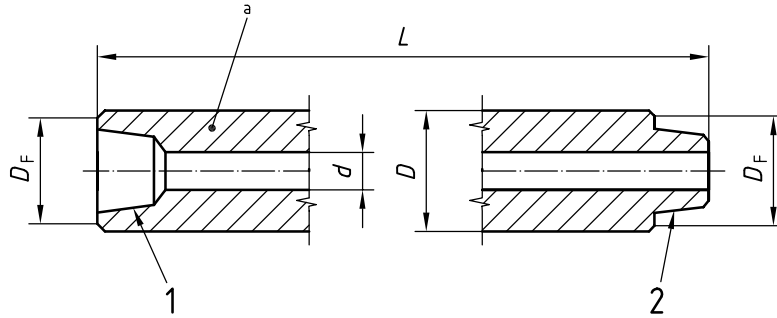

Key

- 1 rotary box connection
- 2 rotary pin connection

^a See Table 14 and Table 20 for dimensions.

Figure 8 — Drill collars

Table 14 — Drill collars

1	2	3	4	5	6
Drill collar number and connection label ^{a, b}	Outside diameter ^c	Bore	Length	Bevel diameter	Reference bending strength ratio
	<i>D</i>	<i>d</i>	<i>L</i>	<i>D_F</i>	BSR ^e
	mm	mm	m	mm	
		+1,59 0	± 152,4 mm ^d	± 0,4 mm	
NC23 – 31	79,4	31,8	9,14	76,2	2,57:1
NC 26 – 35	88,9	38,1	9,14	82,9	2,42:1
NC31 – 41	104,8	50,8	9,14 or 9,45	100,4	2,43:1
NC 35 – 47	120,6	50,8	9,14 or 9,45	114,7	2,58:1
NC 38 – 50	127,0	57,2	9,14 or 9,45	121,0	2,38:1
NC 44 – 60	152,4	57,2	9,14 or 9,45	144,5	2,49:1
NC 44 – 60	152,4	71,4	9,14 or 9,45	144,5	2,84:1
NC 44 – 62	158,8	57,2	9,14 or 9,45	149,2	2,91:1
NC46 – 62	158,8	71,4	9,14 or 9,45	150,0	2,63:1
NC46 – 65	165,1	57,2	9,14 or 9,45	154,8	2,76:1
NC46 – 65	165,1	71,4	9,14 or 9,45	154,8	3,05:1
NC46 – 67	171,4	57,2	9,14 or 9,45	159,5	3,18:1
NC 50 – 70	177,8	57,2	9,14 or 9,45	164,7	2,54:1
NC 50 – 70	177,8	71,4	9,14 or 9,45	164,7	2,73:1
NC50 – 72	184,2	71,4	9,14 or 9,45	169,5	3,12:1
NC56 – 77	196,8	71,4	9,14 or 9,45	185,3	2,70:1
NC56 – 80	203,2	71,4	9,14 or 9,45	190,1	3,02:1
6 5/8 REG	209,6	71,4	9,14 or 9,45	195,6	2,93:1

Table 14 (continued)

1	2	3	4	5	6
Drill collar number and connection label ^{a, b}	Outside diameter ^c	Bore	Length	Bevel diameter	Reference bending strength ratio
	D mm	d mm $+1,59$ 0	L m $\pm 152,4$ mm ^d	D_F mm $\pm 0,4$ mm	BSR ^e
NC61 – 90	228,6	71,4	9,14 or 9,45	212,7	3,17:1
7 5/8 REG	241,3	76,2	9,14 or 9,45	223,8	2,81:1
NC70 - 97	247,6	76,2	9,14 or 9,45	232,6	2,57:1
NC70– 100	254,0	76,2	9,14 or 9,45	237,3	2,81:1
8 5/8 REG	279,4	76,2	9,14 or 9,45	266,7	2,84:1

NOTE See Figure 8 for configuration of drill collars.

^a Labels are for information and assistance in ordering.

^b The drill collar number consists of two parts separated by a hyphen. The first part is the connection number in the NC style. The second part, consisting of 2 (or 3) digits, indicates the drill collar outside diameter in units and tenths of inches. Drill collars with 209,6 mm, 241,3 mm and 279,4 mm outside diameters are shown with 6 5/8, 7 5/8 and 8 5/8 REG connections, since there are no NC connections in the recommended range of bending-strength ratios.

^c See Table 15 for tolerances.

^d See 8.3.1.1 for non-magnetic drill collar tolerances.

^e Stress-relief features are disregarded in the calculation of the bending-strength ratio.

Table 15 — Drill collar OD tolerances

Dimensions and tolerances in millimetres

1	2	3	4
Outside diameter	Size tolerance inclusive		Out-of-roundness ^a
	max.	min.	
Over 63,5 to 88,9 inclusive	1,2	0	0,89
Over 88,9 to 114,3 inclusive	1,6	0	1,17
Over 114,3 to 139,7 inclusive	2,0	0	1,47
Over 139,7 to 165,1 inclusive	3,2	0	1,78
Over 165,1 to 209,6 inclusive	4,0	0	2,16
Over 209,6 to 241,3 inclusive	4,8	0	2,54
Over 241,3	6,4	0	3,05

^a Out-of-roundness is the difference between the maximum and minimum diameters of the bar or tube, measured in the same cross-section, and does not include surface-finish tolerances outlined in 8.1.4

Table 16 — Drill collar surface imperfection removal and inspection reference standard notch depth

Dimensions in millimetres

1	2	3
Outside diameter	Stock removal from surface max.	Reference standard notch depth max.
Over 63,5 to 88,9 inclusive	1,83	1,83
Over 88,9 to 114,3 inclusive	2,29	2,29
Over 114,3 to 139,7 inclusive	2,79	2,79
Over 139,7 to 165,1 inclusive	3,18	3,18
Over 165,1 to 209,6 inclusive	3,94	3,94
Over 209,6 to 241,3 inclusive	5,16	5,16
Over 241,3	12,19	6,10

Table 17 — Mechanical properties and tests for new standard steel drill collars

1	2	3	4	5
Drill collar OD range mm	Yield strength MPa min.	Tensile strength MPa min.	Elongation, with gauge length four times diameter % min.	Brinell hardness HBW min.
79,4 through 174,6	758	965	13	285
177,8 through 279,4	689	931	13	285

Table 18 — Mechanical properties and tests for new non-magnetic drill collars

Drill collar OD range mm	Stainless steels			Beryllium copper		
	Yield strength MPa min.	Tensile strength MPa min.	Elongation % min.	Yield strength MPa min.	Tensile strength MPa min.	Elongation % min.
88,9 through 174,6	758	827	18	758	965	12
177,8 through 279,4	689	758	20	689	931	13

Table 19 — Lower connections for bottom hole drill collars

Dimensions in millimetres

Outside diameter of drill collar	Bottom box connection Label ^a	Bevel diameter ± 0,4
104,8 to 114,3 inclusive	2 7/8 REG	91,7
120,6 to 127,0 inclusive	3 1/2 REG	104,4
152,4 to 177,8 inclusive	4 1/2 REG	135,3
177,8 to 184,2 inclusive	5 1/2 REG	165,1
196,8 to 228,6 inclusive	6 5/8 REG	186,9
241,3 to 254,0 inclusive	7 5/8 REG	215,1
279,4 inclusive	8 5/8 REG	242,5

^a Labels are for information and assistance in ordering.

Table 20 — Additional non-magnetic drill collar sizes

1	2	3	4	5	6
Drill collar number	Outside diameter D^a mm	Bore d $+1,6$ 0 mm	Length L $+0,152$ 0 m	Bevel diameter D_F ± 0,4 mm	Reference bending strength ratio ^b BSR
NC 50-67	171,4	71,4	9,14 or 9,45	159,5	2.37:1

NOTE See Figure 8 for configuration of drill collar.

^a See Table 15 for tolerances.

^b The NC50-67 with 71,4 ID has a bending-strength ratio of 2,37:1, which is more pin-strong than normally acceptable for standard steel drill collars but has proven to be acceptable for non-magnetic drill collars.

Dimensions in millimetres (inches)

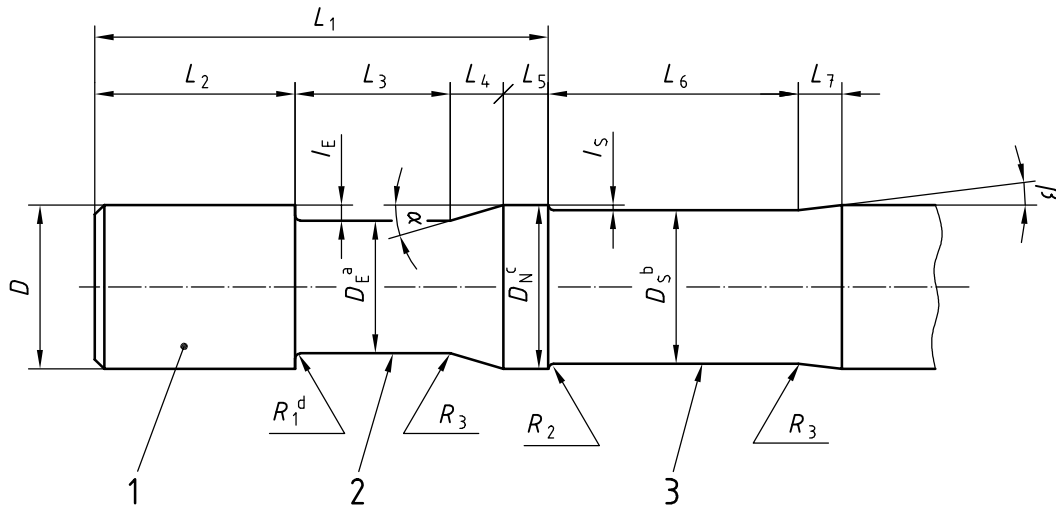

L_1	L_2	L_3	L_4	L_5	L_6	L_7	R_2	R_3
1067 Ref	508^{+51}_0	406^{+25}_0	76 Ref	76 Ref	457^{+51}_0	76 Ref	25,4 Ref	50,8 Ref
(42 Ref)	(20^{+2}_0)	(16^{+1}_0)	(3 Ref)	(3 Ref)	(18^{+2}_0)	(3 Ref)	(1 Ref)	(2 Ref)

Key

- 1 box end
- 2 elevator groove
- 3 slip groove

- a $D_E = D - 2 \times l_E$.
- b $D_S = D - 2 \times l_S$.
- c $D_N = D + 1,6$ (1/16) maximum.
- d See Table 21 for dimensions.

Figure 9 — Drill collar slip and elevator grooves

Table 21 — Drill collar slip and elevator groove and elevator bore dimensions

Dimensions in millimetres

1	2	3	4	5	6	7	8
Groove dimensions based on drill collar OD						Elevator bores based on drill collar OD	
Drill collar OD ranges	Elevator groove depth l_E^a $\pm 0,2$	R_1^c	Angle α^b	Slip groove depth l_s^a $\pm 0,4$	Angle β^b	Top bore $\begin{matrix} 0 \\ -0,8 \end{matrix}$	Bottom bore $\begin{matrix} +1,6 \\ 0 \end{matrix}$
101,6 to 117,5	5,6	$3,2 \pm 0,4$	4°	4,8	$3,5^\circ$	OD minus 7,9	OD plus 3,2
120,6 to 142,9	6,4	$3,2 \pm 0,4$	5°	4,8	$3,5^\circ$	OD minus 9,5	OD plus 3,2
146,0 to 168,3	7,9	$3,2 \pm 0,4$	6°	6,4	5°	OD minus 12,7	OD plus 3,2
171,4 to 219,1	9,5	$4,8 \pm 0,8$	$7,5^\circ$	6,4	5°	OD minus 14,3	OD plus 3,2
222,2 and larger	11,1	$6,4 \pm 0,8$	9°	6,4	5°	OD minus 15,9	OD plus 3,2

^a l_E and l_s dimensions are from the nominal OD of the drill collar.

^b Angles α and β values are reference and approximate.

^c Cold work radius R1.

9 Drilling and coring bits

9.1 Roller bits and blade drag bits

9.1.1 Size

Roller bits shall be furnished with sizes as specified on the purchase order. Blade drag bits shall be furnished in the sizes specified on the purchase order.

NOTE See API RP 7G for commonly used sizes for roller bits.

9.1.2 Tolerances

The gauge diameter of the cutting edge of the bit shall conform to the OD tolerances specified in Table 22.

Table 22 — Roller bit and drag bit tolerances

Size of bit mm	Tolerance mm
44,4 to 349,2 inclusive	$\begin{matrix} +0,8 \\ 0 \end{matrix}$
355,6 to 444,5 inclusive	$\begin{matrix} +1,6 \\ 0 \end{matrix}$
447,7 and larger	$\begin{matrix} +2,4 \\ 0 \end{matrix}$

9.1.3 Connections

Roller bits shall be furnished in the size and style of the pin connection shown in Table 23. Blade drag bits shall be furnished with the size and style of connection shown in Table 24 and shall be pin or box.

9.1.4 Marking

Bits shall be die-stamped in some location other than the make-up shoulder with the following information:

- a) manufacturer's name or identification mark,
- b) the bit size,
- c) "ISO 10424-1",
- d) the size and style of connection.

EXAMPLE A 200 mm (7 7/8 in) bit with 4 1/2 REG rotary shouldered connection shall be stamped as follows:

A B Co (or mark) 200 ISO 10424-1 4 1/2 REG

9.2 Diamond drilling bits, diamond core bits and polycrystalline diamond compact (PDC) bits

9.2.1 Diamond bit tolerances

Diamond drilling bits, diamond core bits, and polycrystalline diamond compact (PDC) bits shall be subject to the OD tolerances shown in Table 25.

9.2.2 Diamond drilling bit and PDC bit connections

Diamond drilling bits and PDC bits shall be furnished with the size and style pin connection shown in Table 26. All connection threads shall be right-hand.

Because of their proprietary nature, the connections on diamond core bits are not shown.

9.2.3 Diamond bit and PDC bit gauging

9.2.3.1 General

All diamond and PDC bits shall have the outer diameter inspected using the dimensional guidelines for ring gauges given in 9.2.3.2 and 9.2.3.3.

9.2.3.2 Gauge specification

"Go" and "no-go" gauges should be fabricated as shown in Figure 10 and as described below.

- a) "Go" and "no-go" gauges should be a ring fabricated from 25,4 mm (1 in) steel with OD equal to the nominal bit size plus 38,1 mm (1 1/2 in).
- b) The "go" gauge ID should equal the nominal bit size plus 0,05 mm (0,002 in) clearance, with a tolerance of +0,08 mm, 0 mm (+ 0.003 in, 0 in).
- c) The "no-go" gauge ID should equal the minimum bit size (nominal size less maximum negative tolerance) minus 0,05 mm (0.002 in) interference, with a tolerance of 0 mm, - 0,08 mm (0 in, - 0.003 in).

9.2.3.3 Gauging practice

The "go" and "no-go" gauges should be used as follows.

- a) If acceptable, the product bit should enter the "go" gauge (product not too large).
- b) If acceptable, the product bit should not enter the "no go" gauge (product not too small).
- c) For accurate measurement, the temperature of both the "go" and "no-go" gauges should be within 11 °C (20 °F) of the temperature of the bit or corehead.

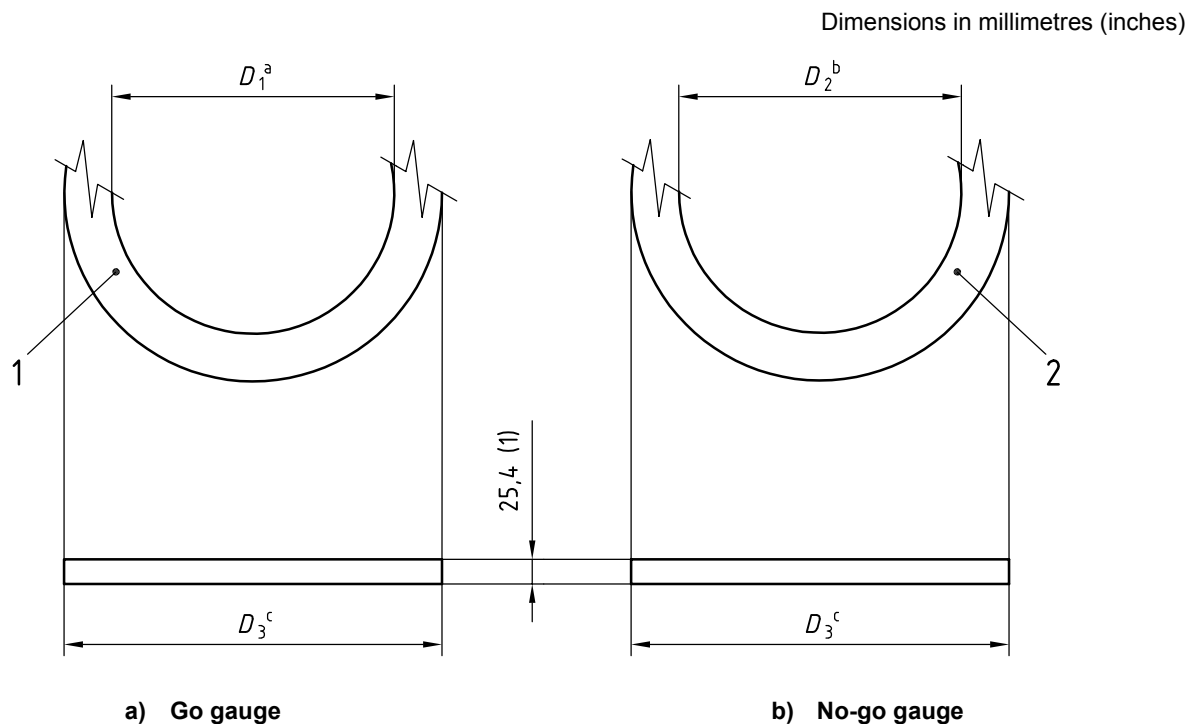
**Key**

- 1 “go” gauge
2 “no-go” gauge

^a $D_1 = \text{Bit size} + 0,05 (+0.002)$. Tolerance on D_1 is $\begin{matrix} +0,08 \\ 0 \end{matrix} (\begin{matrix} +0,003 \\ 0 \end{matrix})$.

^b $D_2 = \text{Bit size} - \text{negative tolerance} - 0,05 (-0.002)$. Tolerance on D_2 is $\begin{matrix} 0 \\ -0,08 \end{matrix} (\begin{matrix} 0 \\ -0,003 \end{matrix})$.

^c $D_3 = \text{Nominal bit size} + 38,1 (1.5)$ minimum.

Figure 10 — Gauge dimensions for diamond and PDC bits

9.2.4 Marking

Diamond drilling bits, diamond core bits and PDC bits shall be marked as follows.

- a) Diamond drilling bits and PDC bits shall be permanently and legibly identified in some location other than the make-up shoulder with the following information:
- 1) the manufacturer's name or identification mark;
 - 2) the bit size;
 - 3) “ISO 10424–1”;
 - 4) the size and style of connection.

EXAMPLE A 190,5 mm (7 1/2 in) bit with a 4 1/2 REG rotary connection shall be stamped as follows:

A B Co. (or mark) 190,5 ISO 10424-1 4 1/2 REG

- b) Diamond core bits shall be permanently and legibly identified on some location other than the make-up shoulder with the manufacturer's name or identification mark and “ISO 10424–1” as follows:

A B Co. (or mark) ISO 10424-1

Because of their proprietary nature, the connections on diamond core bits are not shown. The marking “ISO 10424–1” shall indicate that the other dimensional requirements of this part of ISO 10424 have been met.

Table 23 — Roller bit connections

Dimensions in millimetres

1	2	3	4
Size of bit OD	Label ^a rotary shouldered pin connection	Bit sub bevel diameter ± 0,4	Bit bevel diameter ± 0,4
44,4 to 56,9 inclusive	1 REG ^b	37,3	38,1
57,2 to 88,6 inclusive	1 1/2 REG ^c	49,2	50,0
88,9 to 114,3 inclusive	2 3/8 REG	77,4	78,2
117,5 to 127,0 inclusive	2 7/8 REG	91,7	92,5
130,2 to 187,3 inclusive	3 1/2 REG	104,4	105,2
190,5 to 238,1 inclusive	4 1/2 REG	135,3	136,1
241,3 to 365,1 inclusive	6 5/8 REG	186,9	187,7
368,3 to 469,9 inclusive	6 5/8 REG or	186,9	187,7
	7 5/8 REG	215,1	215,9
473,1 to 660,4 inclusive	7 5/8 REG or	215,1	215,9
	8 5/8 REG	242,5	243,3
685,8 and larger	8 5/8 REG	242,5	243,3

^a Labels are for information and assistance in ordering.

^b The 1 REG is interchangeable with most 1 MT, AMT and AMMT threads.

^c The 1 1/2 REG is interchangeable with most 1 1/2 MT, AMT and AMMT threads.

Table 24 — Blade drag bit connections

Dimensions in millimetres

1	2	3	4
Size of bit OD	Label ^a rotary shouldered connection	Bit sub bevel diameter ± 0,4	Bit bevel diameter ± 0,4
44,4 to 56,9 inclusive	1 REG ^b	37,3	38,1
57,2 to 88,6 inclusive	1 1/2 REG ^c	49,2	50,0
88,9 to 114,3 inclusive	2 3/8 REG, pin or box	77,4	78,2
117,5 to 127,0 inclusive	2 7/8 REG, pin or box	91,7	92,5
130,2 to 187,3 inclusive	3 1/2 REG, pin or box	104,4	105,2
190,5 to 215,9 inclusive	4 1/2 REG, pin or box	135,3	136,1
219,1 to 250,8 inclusive	5 1/2 REG, pin or box	165,1	165,9
> 250,8	6 5/8 REG, pin or box	186,9	187,7

^a Labels are for information and assistance in ordering.

^b The 1 REG is interchangeable with most 1 MT, AMT and AMMT threads.

^c The 1 1/2 REG is interchangeable with most 1 1/2 MT, AMT and AMMT threads.

Table 25 — Diamond drilling, diamond core and PDC bit tolerances

Dimensions in millimetres

Bit size OD	OD tolerances ^a
≤ 171,4	0 -0,38
172,2 to 228,6 inclusive	0 -0,51
229,4 to 349,2 inclusive	0 -0,76
350,0 to 444,5 inclusive	0 -1,14
> 445,3	0 -1,60

^a It is recognized that certain applications may warrant the manufacture of PDC bits to tolerances other than those shown in Table 25. When manufactured, such bits are considered outside the scope of this part of ISO 10424.

Table 26 — Diamond drilling bit and PDC bit connections

Dimensions in millimetres

1	2	3	4
Size of bit	Label ^a rotary shouldered pin connection	Bit sub bevel diameter ± 0,4	Bit bevel diameter ± 0,4
44,4 to 56,9 inclusive	1 REG ^b	38,1	38,9
57,2 to 88,6 inclusive	1 1/2 REG ^c	49,2	50,0
88,9 to 114,3 inclusive	2 3/8 REG	77,4	78,2
115,1 to 127,0 inclusive	2 7/8 REG	91,7	92,5
127,8 to 187,3 inclusive	3 1/2 REG	104,4	105,2
188,1 to 238,1 inclusive	4 1/2 REG	135,3	136,1
238,9 to 368,3 inclusive	6 5/8 REG	186,9	187,7
369,9 to 469,9 inclusive	6 5/8 REG or	186,9	187,7
	7 5/8 REG	215,1	215,9
471,5 and larger	7 5/8 REG or	215,1	215,9
	8 5/8 REG	242,5	243,3

^a Labels are for information and assistance in ordering.

^b The 1 REG is interchangeable with most 1 MT, AMT and AMMT threads.

^c The 1 1/2 REG is interchangeable with most 1 1/2 MT, AMT and AMMT threads.

10 Non-destructive examination of bars and tubes

10.1 General

All standard steel bars and tubes shall be examined for both surface-breaking and totally enclosed internal defects.

Non-magnetic bars and tubes shall be examined for totally enclosed internal defects. Examination for surface defects on non-magnetic bars and tubes is not required if the outside surface has been machined.

Non-destructive examination shall take place after the completion of all heat treatment.

10.2 Certification and qualification of NDE personnel

The manufacturer shall develop a programme for certification of NDE personnel. As a minimum, ISO 9712 shall be the basis for certification of NDE personnel.

NOTE For the purposes of this provision, ASNT RP SNT-TC-1A is equivalent to ISO 9712.

The administration of the NDE personnel certification programme shall be the responsibility of the manufacturer.

Inspections shall be conducted by inspectors certified to Level II or III.

10.3 Surface defects

10.3.1 Outside-surface-breaking defects

The outside surface of each standard steel bar or tube shall be inspected for defects. The preferred methods are either the ultrasonic (UT) or magnetic particle (MT) methods. As an option, other methods (such as eddy current) may be used, providing it can be demonstrated that the system and procedures are capable of detecting indications described in Table 16.

Inspection of the outside surface of non-magnetic bars and tubes is not required if the outside surface has been machined. However, by agreement between the manufacturer and purchaser it may be performed. If it is deemed desirable to inspect the outside surface of non-magnetic bars, the surface shall be inspected by either the ultrasonic (UT) or liquid-penetrant (PT) method.

The method used for outside-surface inspection shall be at the discretion of the manufacturer.

10.3.2 Inside-surface-breaking defects

The inside surface of each tube shall be inspected for defects by the ultrasonic (UT) angle-beam (shear wave) method. This requirement applies only to materials that are identifiable as tubes before heat treatment. Materials that are heat-treated as solid bars and have the ID drilled after heat treatment are not considered tubes, for inspection purposes.

10.3.3 Ultrasonic examination method

If ultrasonic testing (UT) is utilized for inspection of the outside and/or inside surfaces, each bar or tube shall be inspected full length with 360° overlapping scans for surface-breaking defects. Either the angle-beam method (shear wave) or an offset straight-beam (to produce shear waves) immersion system may be used.

The inspection shall be performed according to a written procedure developed by the manufacturer to comply with ASTM E 587 for bars and ISO 9303 for tubes (direct contact or immersion methods), except as noted below.

- a) A reference standard shall be used to standardize the system and to demonstrate the effectiveness of the inspection equipment and procedures at least once each working shift and/or each time the nominal OD of the material being inspected changes.
- b) The reference standard, of convenient length, shall be prepared from a length of bar or tube of the same nominal outside diameter, material and heat-treatment as the material examined.
- c) The reference standard shall be free of discontinuities or other conditions producing indications that can interfere with the detection of the reference notch.
- d) The reference standard for solid bars shall contain a longitudinal (axial) reference notch on the outside surface.
- e) The reference standard for tubes shall contain both a longitudinal (axial) reference notch on the outside surface and a longitudinal (axial) reference notch on the inside surface.
- f) The maximum depth of the longitudinal reference notches shall be as stated in Table 16 for the bar or tube size being inspected. At the manufacturer's option, shallower depths may be used.
- g) The longitudinal reference notches shall be of maximum length 152,4 mm (6 in) and of width less than or equal to 1,02 mm (0.040 in).

NOTE For the purposes of this provision, ASTM E 213 is equivalent to ISO 9303.

A drilled-hole reference reflector may be used as an alternative to the above reference notches, on agreement between the manufacturer and the purchaser. The hole diameter shall produce a reflector which is equivalent or more sensitive than the reference notch indicated above. In either case, the reference signal amplitude shall not be used to determine the acceptance or rejection of a component as scanned by an automated scanning device. Acceptance and rejection criteria shall be determined by utilizing specific prove-up techniques associated with the particular method(s) used, in conjunction with the requirements of this procedure.

A dynamic standardization check shall be performed at the beginning of each work shift to ensure repeatability, by inspecting the reference standard at production speeds at least two consecutive times. If the amplitude of the notch for one run is less than 79 % of the amplitude from the other run (2 dB), the system shall be adjusted and the dynamic standardization repeated.

The manufacturer shall determine the appropriate frequency of NDE equipment verification in order to be able to certify that all products conform to the requirements of this part of ISO 10424. If equipment, whose calibration or verification is required under the provisions of this part of ISO 10424, is subject to unusual or severe conditions such as would make its accuracy questionable, recalibration or re-verification shall be performed before further use of the equipment.

10.3.4 Magnetic particle examination

If MT is utilized for inspection of the outside surface of standard steel, the full length of each bar or tube shall be inspected by either the dry powder or wet magnetic particle method to detect longitudinal defects.

The inspection of tubes shall be performed in accordance with a written procedure developed by the manufacturer in accordance with ISO 13665.

NOTE 1 For the purposes of this provision, ASTM E 709 is equivalent to ISO 13665.

The inspection of bars shall be performed in accordance with a written procedure developed by the manufacturer in accordance with ISO 9934-1.

NOTE 2 For the purposes of this provision, ASTM E 709 is equivalent to ISO 9934-1.

10.3.5 Liquid penetrant examination

If PT is utilized for inspection of the outside surface, the full length of each bar or tube shall be inspected by either the visible or fluorescent solvent removable or water-washable liquid penetrant method.

The inspection shall be performed in accordance with a written procedure developed by the manufacturer in accordance with ISO 3452.

NOTE For the purposes of this provision, ASTM E 1209, ASTM E 1219, ASTM E 1220, and ASTM E 1418 are equivalent to ISO 3452.

10.3.6 Evaluation of indications

Outside-surface-breaking indications found by the ultrasonic method having an amplitude less than 20 % of the height established by the notch of the reference standard may be used as-is.

Outside-surface-breaking indications found by the ultrasonic method having an amplitude equal to or greater than 20 % of the height established by the notch of the reference standard shall be set aside for depth prove-up.

All outside-surface breaking indications found by magnetic particle or liquid penetrant inspection shall be set aside for depth prove-up.

Prove-up of an outside-surface-breaking defect shall consist of notching to the bottom of the indication, measuring its depth and comparing the depth to the maximum allowable stock removal defined in Table 16.

The indication's depth may be measured by using a mechanical device (for instance, a depth gauge). The depth of removal of material by grinding or other means to facilitate measurement shall not be deeper than outlined in Table 16.

It is not practical to prove-up indications on the inside diameter of tubes.

10.3.7 Acceptance criteria

Indications with depths less than the maximum allowable stock removal permitted in Table 16 may be salvaged by removing the indication by grinding. The bar or tube shall be accepted only after complete removal of the indication. All grinds shall be blended to approximately restore the round appearance of the bar or tube.

Indications with depths greater than the maximum allowable stock removal from surface shown in Table 16 shall be rejected.

Inside-surface-breaking indications found in tubes by the ultrasonic method having an amplitude equal to or greater than 50 % of the height established by the notch of the reference standard shall be rejected.

10.4 Internal defects

10.4.1 General

Each bar or tube shall be inspected for internal defects by the ultrasonic (UT) method.

10.4.2 Internal longitudinal defects

10.4.2.1 General

The full length of each standard steel bar or tube shall be inspected with 360° overlapping scans for longitudinal defects, using both angle-beam (shear wave) transducers and straight-beam (compression wave) transducers.

Inspection of non-magnetic bars and tubes shall be limited to the straight-beam (compression wave) method.

Reference standards shall be used to standardize the inspection unit for each size bar or tube inspected.

The straight-beam inspection shall be performed in accordance with a written procedure developed by the manufacturer in accordance with ISO 9303 except as noted below.

- a) A sound section of the bar or tube shall be used as the compression-wave reference standard.
- b) The reference standard described in 10.3.3 shall be used to establish a reference level for the shear wave inspection.
- c) Transducers shall operate within the range of 1 MHz to 3,5 MHz. Transducers operating at less than 1 MHz may be used on non-magnetic materials.

NOTE For the purposes of this provision, ASTM E 114, ASTM E 214 and ASTM E 1001 are equivalent to ISO 9303.

10.4.2.2 Acceptance criteria for internal longitudinal defects

Any indication in the centre of the bar that results in the loss of 50 % or more of the reference standard's back reflection and that will not be removed by the boring process shall be considered a defect and shall be rejected.

A bar or tube containing an indication in the mid-wall that results in the loss of 40 % or more of the reference standard's back-reflection shall be rejected, unless the manufacturer establishes that the loss of back-reflection is due to large grains, surface condition, or lack of parallelism between the scanning and reflecting surfaces.

Any indication in the mid-wall having an amplitude greater than the 5 % back-reflection amplitude of the reference standard shall be considered a defect, and shall result in rejection of the tube or bar.

10.4.3 Internal transverse defects

10.4.3.1 General

Each bar shall be inspected for internal transverse defects. Inspection shall be by one of the following methods:

- a) direct-contact straight-beam method with the transducer placed on the end (face) of the bar or tube;
- b) direct-contact shear-wave method with the sound beam oriented in the longitudinal axis of the bar so as to perpendicularly intersect suspected discontinuities.

The method used shall be the option of the manufacturer.

It is not necessary to inspect tubes for transverse defects.

10.4.3.2 Acceptance criteria for internal transverse defects

All internal transverse indications that will not be removed by the boring process shall be rejected.

Annex A (informative)

Tables in US Customary Units

Table A.1 — Hydrostatic testing pressures

Maximum working pressure rating psi	Hydrostatic shell test pressure (new valves only) psi
5 000	10 000
10 000	15 000
15 000	22 500

Table A.2 — Adjustment factors for impact specimens

Specimen dimensions in × in	Adjustment factor
0.394 × 0.394	1.00
0.394 × 0.295	0.833
0.394 × 0.197	0.667

Table A.3 — Service class definitions

Class No.	Service type	Design performance requirements for pressure sealing
Class 1 ^a	Surface only	Body and any stem seal shall hold internal pressure equal to the shell test pressure ^b Closure seal shall hold pressure from below at a low pressure of 250 psi and at a high pressure equal to the maximum rated working pressure
Class 2	Surface and downhole	Body and any stem seal shall hold internal pressure equal to the shell test pressure ^b Stem seal shall hold external pressure at a low pressure of 250 psi and at a minimum high pressure of 2 000 psi ^c Closure seal shall hold pressure from below at a low pressure of 250 psi and at a high pressure equal to the maximum rated working pressure Closure seal shall hold pressure from above at a low pressure of 250 psi and at a high pressure equal to the maximum rated working pressure ^d Sealing temperature range verified by testing ^e
^a Valves manufactured to the 39 th and earlier editions of API Spec 7 qualify as Class 1 valves. To re-classify existing valves as Class 2 shall require testing in accordance with the requirements of 5.4.3, 5.4.4 and 5.4.5. ^b Shell test only performed once, in accordance with the values in Table 3, for each valve manufactured. ^c Stem seal performance verified once for each valve design, not for each valve manufactured. ^d Only applies to ball-type valves. ^e Sealing temperature range verified once for each valve design, not for each valve manufactured.		

Table A.4 — Square kelly drive section

1	2	3	4	5	6	7	8	9	10	11
Kelly size ^a	Length Drive section ft		Length overall ft		Across flats	Across corners	Across corners	Radius	Radius	Wall thickness eccentric bore
	Standard L_D +0.50 -0.42	Optional L_D +0.50 -0.42	Standard L +0.50 0	Optional L +0.50 0	in D_{FL} ^b	in D_C ^c	in D_{CC} 0 -0.015	in R_C ± 1/16	in R_{CC} Ref. only	in t min.
2 1/2	37	—	40	—	2 1/2	3 9/32	3.250	5/16	1 5/8	0.450
3	37	—	40	—	3	3 15/16	3.875	3/8	1 15/16	0.450
3 1/2	37	—	40	—	3 1/2	4 17/32	4.437	1/2	2 7/32	0.450
4 1/4	37	51	40	54	4 1/4	5 9/16	5.500	1/2	2 3/4	0.475
5 1/4	37	51	40	54	5 1/4	6 29/32	6.750	5/8	3 3/8	0.625
NOTE See Figure 2 for configuration of square drive section.										
<p>^a Size of square kellys is the same as the dimension D_{FL} across flats (distance between opposite faces) as given in Column 6.</p> <p>^b Tolerances on D_{FL}, sizes 2 1/2 to 3 1/2 inclusive: $^{+5/64}_0$ in; sizes 4 1/4 to 5 1/4 inclusive: $^{+3/32}_0$ in. See 6.2 for sleeve test.</p> <p>^c Tolerances on D_C, sizes 2 1/2 to 3 1/2 inclusive: $^{+1/8}_0$ in; sizes 4 1/4 to 5 1/4 inclusive: $^{+5/32}_0$ in.</p>										

Table A.5 — Square kelly end upsets and connections

Dimensions in inches

1	2	3	4	5	6	7	8	9	10	11
Kelly size ^b	Upper box connection ^a					Lower pin connection ^a				
	Label ^c	Outside diameter	Bevel diameter	Upset Length	Label ^c	Outside diameter	Inside diameter	Bevel diameter	Upset length	
		D_U $\pm 1/32$	D_F $\pm 1/64$	L_U $+2\ 1/2$ 0		D_{LR} $\pm 1/32$	d $+1/16$ 0	D_F $\pm 1/64$	L_L $+2\ 1/2$ 0	
2 1/2	Standard	6 5/8 REG	7 3/4	7 21/64	16	NC26	3 3/8	1 1/4	3 17/64	20
	Optional	4 1/2 REG	5 3/4	5 19/64	16	NC26	3 3/8	1 1/4	3 17/64	20
3	Standard	6 5/8 REG	7 3/4	7 21/64	16	NC31	4 1/8	1 3/4	3 61/64	20
	Optional	4 1/2 REG	5 3/4	5 19/64	16	NC31	4 1/8	1 3/4	3 61/64	20
3 1/2	Standard	6 5/8 REG	7 3/4	7 21/64	16	NC38	4 3/4	2 1/4	4 37/64	20
	Optional	4 1/2 REG	5 3/4	5 19/64	16	NC38	4 3/4	2 1/4	4 37/64	20
4 1/4	Standard	6 5/8 REG	7 3/4	7 21/64	16	NC46	6 1/4	2 13/16	5 23/32	20
	Standard	6 5/8 REG	7 3/4	7 21/64	16	NC50	6 3/8	2 13/16	6 1/16	20
	Optional	4 1/2 REG	5 3/4	5 19/64	16	NC46	6 1/4	2 13/16	5 23/32	20
	Optional	4 1/2 REG	5 3/4	5 19/64	16	NC50	6 3/8	2 13/16	6 1/16	20
5 1/4	Standard	6 5/8 REG	7 3/4	7 21/64	16	5 1/2 FH	7	3 1/4	6 23/32	20
	Standard	6 5/8 REG	7 3/4	7 21/64	16	NC56	7	3 1/4	6 47/64	20

NOTE See Figure 2 for configuration of end upsets.

^a See 6.3 for requirements of rotary shouldered connections.

^b Size of square kellys is the same as the dimension D_{FL} across flats (distance between opposite faces) as given in Column 6 of Table A.4.

^c Labels are for information and assistance in ordering.

Table A.6 — Hexagonal kelly drive section

1	2	3	4	5	6	7	8	9	10	11
Kelly size ^a	Length drive section ft		Length overall ft		Across flats in D_{FL} $+1/32$ 0	Across corners in D_C $\pm 1/32$	Across corners in D_{CC} 0 -0.015	Radius in R_C $\pm 1/32$	Radius in R_{CC} Ref only	Wall thickness eccentric bore in t min.
	Standard L_D $+0.50$ -0.42	Optional L_D $+0.50$ -0.42	Standard L $+0.50$ 0	Optional L $+0.50$ 0						
3	37	—	40	—	3	3 3/8	3.375	1/4	1 11/16	0.475
3 1/2	37	—	40	—	3 1/2	3 31/32	3.937	1/4	1 31/32	0.525
4 1/4	37	51	40	54	4 1/4	4 13/16	4.781	5/16	2 25/64	0.625
5 1/4	37	51	40	54	5 1/4	5 31/32	5.900	3/8	2 61/64	0.625
6	37	51	40	54	6	6 13/16	6.812	3/8	3 13/32	0.625

NOTE See Figure 3 for configuration of hexagonal drive section.

^a Size of hexagonal kellys is the same as the dimension D_{FL} across flats (distance between opposite faces) as given in Column 6.

Table A.7 — Hexagonal kelly end upsets and connections

Dimensions in inches

1	2	3	4	5	6	7	8	9	10	11
Kelly size ^b	Upper box connection ^a					Lower pin connection ^a				
	Label ^c	Outside diameter D_U $\pm 1/32$	Bevel diameter D_F $\pm 1/64$	Upset length L_U $+2 1/2$ 0	Label ^c	Outside diameter D_{LR} $\pm 1/32$	Inside diameter d $+1/16$ 0	Bevel diameter D_F $\pm 1/64$	Upset length L_L $+2 1/2$ 0	
3	Standard	6 5/8 Reg	7 3/4	7 21/64	16	NC 26	3 3/8	1 1/4	3 17/64	20
	Optional	4 1/2 Reg	5 3/4	5 19/64	16	NC 26	3 3/8	1 1/4	3 17/64	20
3 1/2	Standard	6 5/8 Reg	7 3/4	7 21/64	16	NC31	4 1/8	1 3/4	3 61/64	20
	Optional	4 1/2 Reg	5 3/4	5 19/64	16	NC31	4 1/8	1 3/4	3 61/64	20
4 1/4	Standard	6 5/8 Reg	7 3/4	7 21/64	16	NC38	4 3/4	2 1/4	4 37/64	20
	Optional	4 1/2 Reg	5 3/4	5 19/64	16	NC38	4 3/4	2 1/4	4 37/64	20
5 1/4	Standard	6 5/8 Reg	7 3/4	7 21/64	16	NC46	6 1/4	3 ^d	5 23/32	20
	Standard	6 5/8 Reg	7 3/4	7 21/64	16	NC50	6 3/8	3 1/4 ^d	6 1/16	20
6	Standard	6 5/8 Reg	7 3/4	7 21/64	16	5 1/2 FH	7	3 1/2	6 23/32	20
	Standard	6 5/8 Reg	7 3/4	7 21/64	16	NC56	7	3 1/2	6 47/64	20

NOTE See Figure 3 for configuration of end upsets.

^a See 6.3 for requirements of rotary shouldered connections.

^b Size of hexagonal kellys is the same as the dimension D_{FL} across flats (distance between opposite faces) as given in Column 6 of Table A.6.

^c Labels are for information and assistance in ordering.

^d For 5 1/4 hexagonal kellys, a bore of 2 13/16 in shall be optional.

Table A.8 — Kelly sleeve gauge

Dimensions in inches

Kelly size	Minimum length of gauge L_G	Distance across flats		Maximum fillet radius	
		Square $D_{FL}^{a, b}$	Hexagonal $D_{FL}^{a, b}$	Square R_S	Hexagonal R_H
2 1/2	10	2.594	—	1/4	—
3	10	3.094	3.036	5/16	3/16
3 1/2	10	3.594	3.536	7/16	3/16
4 1/4	12	4.375	4.286	7/16	1/4
5 1/4	12	5.375	5.286	9/16	5/16
6	12	—	6.036	—	5/16

NOTE See Figure 4 for configuration of kelly sleeve gauge.

^a Tolerances on D_{FL} , all sizes: $^{+0.005}_0$ in.

^b Tolerances on nominal included angles between flats: $\pm 0.5^\circ$.

Table A.9 — Mechanical properties and test — New kellys (all sizes)

Lower upset OD in	Lower upset yield strength psi min.	Lower upset tensile strength psi min.	Elongation % min.	Brinell hardness HBW min.
3 3/8 to 6 7/8	110 000	140 000	13	285
7	100 000	135 000	13	285

Table A.10 — Drill stem subs

1	2	3	4
Type	Class	Upper connection to assemble with	Lower connection to assemble with
A or B	kelly sub	kelly	tool joint
A or B	tool joint sub	tool joint	tool joint
A or B	crossover sub	tool joint	drill collar
A or B	drill collar sub	drill collar	drill collar
A or B	bit sub	drill collar	bit
C	swivel sub	swivel stem	kelly
D	lift sub	elevator	drill collar

Table A.11 — Minimum surface hardness of dimension D_R of Type B drill stem subs

1	2
Large OD D in	Surface Brinell hardness of reduced diameter section D_R HBW min.
3 1/8 through 6 7/8	285
7 through 10	277

Table A.12 — Dimensional data for lift sub upper lift diameters

Dimensions in inches

Elevator recess diameter	Diameter of lift shoulder (tapered or square)	Overall length	Top length	Elevator Recess length	Bottom length
D_P	D_L	L_1	L_2	L_3	L_4
$\pm 1/32$	$\begin{smallmatrix} +1/8 \\ 0 \end{smallmatrix}$	$\begin{smallmatrix} +3 \\ -1 \end{smallmatrix}$	$\pm 1/8$	Ref.	$\pm 1/2$
2 3/8	3 3/8	36	4	18	14
2 7/8	4 1/8	36	4	18	14
3 1/2	4 3/4	36	4	18	14
4	6	36	4	18	14
4 1/2	6 1/4	36	4	18	14
5	6 1/2	36	4	18	14
5 1/2	7	36	4	18	14
6 5/8	8	36	4	18	14

Table A.13 — Float valve recess in bit subs

Dimensions in inches

Diameter of valve assembly D (Reference)	Diameter of float recess D_{FR}^a $\begin{smallmatrix} +1/64 \\ 0 \end{smallmatrix}$	Length of valve assembly L_{FV} (Reference)	API REG bit box			Other popular connections	
			Label ^b	L_R $\pm 1/16$	D_{BP} $\begin{smallmatrix} +1/32 \\ 0 \end{smallmatrix}$	Label ^b	L_R $\pm 1/16$
1 21/32	1 11/16	5 7/8	2 3/8 Reg	9 1/8	1 5/16	NC23	9 1/8
1 29/32	1 15/16	6 1/4	2 7/8 Reg	10	1 1/2	NC26	9 1/2
2 13/32	2 7/16	6 1/2	3 1/2 Reg	10 1/2	1 29/32	NC31	10 1/4
2 13/16	2 27/32	10	—	—	—	3 1/2 FH	14
3 1/8	3 5/32	10	—	—	—	NC38	14 1/4
3 15/32	3 1/2	8 5/16	4 1/2 Reg	12 13/16	2 15/16	NC44	13 1/16
3 21/32	3 11/16	12	—	—	—	NC46	16 3/4
3 7/8	3 29/32	9 3/4	5 1/2 Reg	14 3/4	3 3/8	NC50	14 1/2
4 25/32	4 13/16	11 3/4	6 5/8 Reg	17	4 9/32	5 1/2 IF	17
4 25/32	4 13/16	11 3/4	7 5/8 Reg	17 1/4	4 9/32	5 1/2 FH	17
4 25/32	4 13/16	11 3/4	8 5/8 Reg	17 3/8	4 9/32	NC61	17 1/2
5 11/16	5 23/32	14 5/8	8 5/8 Reg	20 1/4	5 3/16	6 5/8 IF	19 7/8

^a Diameter D_{FR} equals $D + 1/32$ in.

^b Labels are for information and assistance in ordering.

Table A.14 — Drill collars

1	2	3	4	5	6
Drill collar number and connection label ^{a, b}	Outside diameter ^c	Bore	Length ^d	Bevel diameter	Reference bending strength ratio
	<i>D</i>	<i>D</i>	<i>L</i>	<i>D_F</i>	
	in	in $+1/16$ 0	ft ± 6 in	in $\pm 1/64$ in	BSR ^e
NC23 – 31	3 1/8	1 1/4	30	3	2.57:1
NC 26 – 35	3 1/2	1 1/2	30	3 17/64	2.42:1
NC31 – 41	4 1/8	2	30 or 31	3 61/64	2.43:1
NC 35 – 47	4 3/4	2	30 or 31	4 33/64	2.58:1
NC 38 – 50	5	2 1/4	30 or 31	4 49/64	2.38:1
NC 44 – 60	6	2 1/4	30 or 31	5 11/16	2.49:1
NC 44 – 60	6	2 13/16	30 or 31	5 11/16	2.84:1
NC 44 – 62	6 1/4	2 1/4	30 or 31	5 7/8	2.91:1
NC46 – 62	6 1/4	2 13/16	30 or 31	5 29/32	2.63:1
NC46 – 65	6 1/2	2 1/4	30 or 31	6 3/32	2.76:1
NC46 – 65	6 1/2	2 13/16	30 or 31	6 3/32	3.05:1
NC46 – 67	6 3/4	2 1/4	30 or 31	6 9/32	3.18:1
NC 50 – 70	7	2 1/4	30 or 31	6 31/64	2.54:1
NC 50 – 70	7	2 13/16	30 or 31	6 31/64	2.73:1
NC50 – 72	7 1/4	2 13/16	30 or 31	6 43/64	3.12:1
NC56 – 77	7 3/4	2 13/16	30 or 31	7 19/64	2.70:1
NC56 – 80	8	2 13/16	30 or 31	7 31/64	3.02:1
6 5/8 REG	8 1/4	2 13/16	30 or 31	7 45/64	2.93:1
NC61 – 90	9	2 13/16	30 or 31	8 3/8	3.17:1
7 5/8 REG	9 1/2	3	30 or 31	8 13/16	2.81:1
NC70 - 97	9 3/4	3	30 or 31	9 5/32	2.57:1
NC70– 100	10	3	30 or 31	9 11/32	2.81:1
8 5/8 REG	11	3	30 or 31	10 1/2	2.84:1

NOTE See Figure 8 for configuration of drill collars.

- ^a Labels are for information and assistance in ordering.
- ^b The drill collar number consists of two parts separated by a hyphen. The first part is the connection number in the NC style. The second part, consisting of 2 (or 3) digits, indicates the drill collar outside diameter in units and tenths of inches. Drill collars with 8 1/4 in, 9 1/2 in, and 11 in outside diameters are shown with 6 5/8, 7 5/8 and 8 5/8 REG connections, since there are no NC connections in the recommended bending strength ratio range.
- ^c See Table A.15 for OD tolerances.
- ^d See 8.3.1.1 for non-magnetic drill collar length tolerances.
- ^e Stress-relief features are disregarded in the calculation of the bending strength ratio.

Table A.15 — Drill collar OD tolerances

Dimensions in inches

1	2	3	4
Size outside diameter	Size tolerance inclusive		Out-of-roundness ^a
	max.	min.	
Over 2 1/2 to 3 1/2 inclusive	3/64	0	0.035
Over 3 1/2 to 4 1/2 inclusive	1/16	0	0.046
Over 4 1/2 to 5 1/2 inclusive	5/64	0	0.058
Over 5 1/2 to 6 1/2 inclusive	1/8	0	0.070
Over 6 1/2 to 8 1/4 inclusive	5/32	0	0.085
Over 8 1/4 to 9 1/2 inclusive	3/16	0	0.100
Over 9 1/2	1/4	0	0.120

^a Out-of-roundness is the difference between the maximum and minimum diameters of the bar or tube, measured in the same cross-section, and does not include surface finish tolerances outlined in 8.1.4.

Table A.16 — Drill collar surface imperfection removal and inspection reference standard notch depth

Dimensions in inches

1	2	3
Size: Outside diameter	Stock removal from surface max.	Reference standard notch depth max.
Over 2 1/2 to 3 1/2 inclusive	0.072	0.072
Over 3 1/2 to 4 1/2 inclusive	0.090	0.090
Over 4 1/2 to 5 1/2 inclusive	0.110	0.110
Over 5 1/2 to 6 1/2 inclusive	0.125	0.125
Over 6 1/2 to 8 1/4 inclusive	0.155	0.155
Over 8 1/4 to 9 1/2 inclusive	0.203	0.203
Over 9 1/2	0.480	0.240

Table A.17 — Mechanical properties and tests for new standard steel drill collars

1	2	3	4	5
Drill collar OD range	Yield strength	Tensile strength	Elongation, with gauge length four times diameter	Brinell hardness
in	psi min.	psi min.	% min.	HBW min.
3 1/8 through 6 7/8	110 000	140 000	13	285
7 through 11	100 000	135 000	13	285

Table A.18 — Mechanical properties and tests for new non-magnetic drill collars

Drill collar OD range in	Stainless steels			Beryllium copper		
	Yield strength psi min.	Tensile strength psi min.	Elongation % min.	Yield strength psi min.	Tensile strength psi min.	Elongation, % min.
3 1/2 through 6 7/8	110 000	120 000	18	110 000	140 000	12
7 through 11	100 000	110 000	20	100 000	135 000	13

Table A.19 — Lower connections for bottom-hole drill collars

Dimensions in inches

Outside diameter of drill collar	Bottom box connection Label ^a	Bevel diameter ± 1/64
4 1/8 to 4 1/2 inclusive	2 7/8 REG	3 39/64
4 3/4 to 5 inclusive	3 1/2 REG	4 7/64
6 to 7 inclusive	4 1/2 REG	5 21/64
7 to 7 1/4 inclusive	5 1/2 REG	6 1/2
7 3/4 to 9 inclusive	6 5/8 REG	7 23/64
9 1/2 to 10 inclusive	7 5/8 REG	8 15/32
11 inclusive	8 5/8 REG	9 35/64

^a Labels are for information and assistance in ordering.

Table A.20 — Additional non-magnetic drill collar sizes

1	2	3	4	5	6
Drill collar number	Outside diameter ^a <i>D</i> in	Bore <i>d</i> +1/16 0 in	Length <i>L</i> +0,5 0 ft	Bevel diameter <i>D_F</i> ± 1/64 in	Reference bending strength ratio ^b (BSR)
NC 50-67	6 3/4	2 13/16	30 or 31	6 9/32	2.37:1

NOTE See Figure 8 for configuration of drill collar.

^a See Table A.15 for tolerances.

^b The NC50-67 with 2 13/16 ID has a bending strength ratio of 2,37:1, which is more pin-strong than normally acceptable for standard steel drill collars but has proven to be acceptable for non-magnetic drill collars.

Table A.21 — Drill collar slip and elevator groove and elevator bore dimensions

Dimensions in inches

1	2	3	4	5	6	7	8
Groove dimensions based on drill collar OD						Elevator bores based on drill collar OD	
Drill collar OD ranges	Elevator groove depth l_E^a ± 0.008	R_1^c	Angle α^b	Slip groove depth l_s^a $\pm 1/64$	Angle β^b	Top bore $\begin{matrix} 0 \\ -1/32 \end{matrix}$	Bottom bore $\begin{matrix} +1/16 \\ 0 \end{matrix}$
4 to 4 5/8	7/32	1/8 \pm 1/64	4°	3/16	3.5°	OD minus 5/16	OD plus 1/8
4 3/4 to 5 5/8	1/4	1/8 \pm 1/64	5°	3/16	3.5°	OD minus 3/8	OD plus 1/8
5 3/4 to 6 5/8	5/16	1/8 \pm 1/64	6°	1/4	5°	OD minus 1/2	OD plus 1/8
6 3/4 to 8 5/8	3/8	3/16 \pm 1/32	7.5°	1/4	5°	OD minus 9/16	OD plus 1/8
8 3/4 and larger	7/16	1/4 \pm 1/32	9°	1/4	5°	OD minus 5/8	OD plus 1/8

a l_E and l_s dimensions are from the nominal OD of the drill collar.
 b Angles α and β values are reference and approximate.
 c Cold work radius R_1 .

Table A.22 — Roller bit and drag bit tolerances

Size of bit in	Tolerance in
1.75 to 13 3/4 inclusive	$\begin{matrix} +1/32 \\ 0 \end{matrix}$
14 to 17 1/2 inclusive	$\begin{matrix} +1/16 \\ 0 \end{matrix}$
17 5/8 and larger	$\begin{matrix} +3/32 \\ 0 \end{matrix}$

Table A.23 — Roller bit connections

Dimensions in inches

1	2	3	4
Size of bit OD	Label ^a rotary shouldered pin connection	Bit sub bevel diameter ± 1/64	Bit bevel diameter ± 1/64
1.75 to 2.24 inclusive	1 REG ^b	1 15/32	1 1/2
2.25 to 3.49 inclusive	1 1/2 REG ^c	1 15/16	1 31/32
3 1/2 to 4 1/2 inclusive	2 3/8 REG	3 3/64	3 5/64
4 5/8 to 5 inclusive	2 7/8 REG	3 39/64	3 41/64
5 1/8 to 7 3/8 inclusive	3 1/2 REG	4 7/64	4 9/64
7 1/2 to 9 3/8 inclusive	4 1/2 REG	5 21/64	5 23/64
9 1/2 to 14 3/8 inclusive	6 5/8 REG	7 23/64	7 25/64
14 1/2 to 18 1/2 inclusive	6 5/8 REG or	7 23/64	7 25/64
	7 5/8 REG	8 15/32	8 1/2
18 5/8 to 26 inclusive	7 5/8 REG or	8 15/32	8 1/2
	8 5/8 REG	9 35/64	9 37/64
27 and larger	8 5/8 REG	9 35/64	9 37/64

^a Labels are for information and assistance in ordering.

^b The 1 REG is interchangeable with most 1 MT, AMT and AMMT threads.

^c The 1 1/2 REG is interchangeable with most 1 1/2 MT, AMT and AMMT threads.

Table A.24 — Blade drag bit connections

Dimensions in inches

1	2	3	4
Size of bit OD	Label ^a rotary shouldered connection	Bit sub bevel diameter ± 1/64	Bit bevel diameter ± 1/64
1.75 to 2.24 inclusive	1 REG ^b	1 15/32	1 1/2
2.25 to 3.49 inclusive	1 1/2 REG ^c	1 15/16	1 31/32
3 1/2 to 4 1/2 inclusive	2 3/8 REG, pin or box	3 3/64	3 5/64
4 5/8 to 5 inclusive	2 7/8 REG, pin or box	3 39/64	3 41/64
5 1/8 to 7 3/8 inclusive	3 1/2 REG, pin or box	4 7/64	4 9/64
7 1/2 to 8 1/2 inclusive	4 1/2 REG, pin or box	5 21/64	5 23/64
8 5/8 to 9 7/8 inclusive	5 1/2 REG, pin or box	6 1/2	6 17/32
Larger than 9 7/8	6 5/8 REG, pin or box	7 23/64	7 25/64

^a Labels are for information and assistance in ordering.

^b The 1 REG is interchangeable with most 1 MT, AMT and AMMT threads.

^c The 1 1/2 REG is interchangeable with most 1 1/2 MT, AMT and AMMT threads.

Table A.25 — Diamond drilling, diamond core and PDC bit tolerances

Dimensions in inches

1	2
Size of bit OD	OD tolerances ^a
6 3/4 and smaller	0 -0.015
6 25/32 to 9 inclusive	0 -0.020
9 1/32 to 13 3/4 inclusive	0 -0.030
13 25/32 to 17 1/2 inclusive	0 -0.045
17 17/32 and larger	0 -0.063

^a It is recognized that certain applications may warrant the manufacture of PDC bits to tolerances other than those shown in Table A.25. When manufactured, such bits are considered outside the scope of this part of ISO 10424.

Table A.26 — Diamond drilling bit and PDC bit connections

Dimensions in inches

1	2	3	4
Size of bit	Label ^a rotary shouldered pin connection	Bit sub bevel diameter ± 1/64	Bit bevel diameter ± 1/64
1.75 to 2.24 inclusive	1 REG ^b	1 1/2	1 17/32
2.25 to 3.49 inclusive	1 1/2 REG ^c	1 15/16	1 31/32
3 1/2 to 4 1/2 inclusive	2 3/8 REG	3 3/64	3 5/64
4 17/32 to 5 inclusive	2 7/8 REG	3 39/64	3 41/64
5 1/32 to 7 3/8 inclusive	3 1/2 REG	4 7/64	4 9/64
7 13/32 to 9 3/8 inclusive	4 1/2 REG	5 21/64	5 23/64
9 13/32 to 14 1/2 inclusive	6 5/8 REG	7 23/64	7 25/64
14 9/16 to 18 1/2 inclusive	6 5/8 REG or	7 23/64	7 25/64
	7 5/8 REG	8 15/32	8 1/2
18 9/16 and larger	7 5/8 REG or	8 15/32	8 1/2
	8 5/8 REG	9 35/64	9 37/64

^a Labels are for information and assistance in ordering.

^b The 1 REG is interchangeable with most 1 MT, AMT and AMMT threads.

^c The 1 1/2 REG is interchangeable with most 1 1/2 MT, AMT and AMMT threads.

Bibliography

- [1] ISO 11961, *Petroleum and natural gas industries — Steel pipes for use as drill pipe — Specification*
- [2] ISO 13535, *Petroleum and natural gas industries — Drilling and production equipment — Hoisting equipment*
- [3] API Spec 5D, *Drill Pipe*
- [4] API Spec 8A, *Drilling and Production Hoisting Equipment*
- [5] API Spec 8C, *Drilling and Production Hoisting Equipment (PSL 1 & PSL 2)*
- [6] ASNT³⁾ RP SNT-TC-1A:1984, *Personnel qualifications and certification in non-destructive testing*
- [7] ASTM A 370, *Standard Test Methods and Definitions for Mechanical Testing of Steel Products*
- [8] ASTM E 23, *Standard Test Methods for Notched Bar Impact Testing of Metallic Materials*
- [9] ASTM E 114, *Standard Practice for Ultrasonic Pulse-Echo Straight-Beam Examination by the Contact Method*
- [10] ASTM E 213, *Standard Practice for Ultrasonic Examination of Metal Pipe and Tubing*
- [11] ASTM E 214, *Standard Practice for Immersed Ultrasonic Examination by the Reflection Method Using Pulsed Longitudinal Waves*
- [12] ASTM E 709, *Standard Guide for Magnetic Particle Evaluation*
- [13] ASTM E 1001, *Standard Practice for Detection and Evaluation of Discontinuities by the Immersed Pulse-Echo Ultrasonic Method Using Longitudinal Waves*
- [14] ASTM E 1209, *Standard Test Method for Fluorescent Liquid Penetrant Examination Using the Water-Washable Process*
- [15] ASTM E 1219, *Standard Test Method for Fluorescent Liquid Penetrant Examination Using the Solvent-Removable Process*
- [16] ASTM E 1220, *Standard Test Method for Visible Penetrant Examination Using the Solvent-Removable Process*
- [17] ASTM E 1418, *Standard Test Method for Visible Penetrant Examination Using the Water-Washable Process*
- [18] NACE MR0175⁴⁾, *Sulfide Stress Cracking Resistant Metallic Materials for Oilfield Equipment*

3) American Society for Nondestructive Testing, 4153 Arlingate Plaza, Columbus, OH 43228-0518, USA

4) NACE International, P.O. Box 218340, Houston, TX 77218-8340, USA

© International Organization for Standardization

ICS 75.180.10

Price based on 66 pages