**Petroleum and natural gas industries —
Rotary drilling equipment —**

**Part 2:
Inspection and classification of used drill
stem elements**

*Industries du pétrole et du gaz naturel — Équipement de forage
rotatif —*

*Partie 2: Contrôle et classification des éléments de garnitures de forage
usagés*



PDF disclaimer

This PDF file may contain embedded typefaces. In accordance with Adobe's licensing policy, this file may be printed or viewed but shall not be edited unless the typefaces which are embedded are licensed to and installed on the computer performing the editing. In downloading this file, parties accept therein the responsibility of not infringing Adobe's licensing policy. The ISO Central Secretariat accepts no liability in this area.

Adobe is a trademark of Adobe Systems Incorporated.

Details of the software products used to create this PDF file can be found in the General Info relative to the file; the PDF-creation parameters were optimized for printing. Every care has been taken to ensure that the file is suitable for use by ISO member bodies. In the unlikely event that a problem relating to it is found, please inform the Central Secretariat at the address given below.



COPYRIGHT PROTECTED DOCUMENT

© ISO 2008

All rights reserved. Unless otherwise specified, no part of this publication may be reproduced or utilized in any form or by any means, electronic or mechanical, including photocopying and microfilm, without permission in writing from either ISO at the address below or ISO's member body in the country of the requester.

ISO copyright office
Case postale 56 • CH-1211 Geneva 20
Tel. + 41 22 749 01 11
Fax + 41 22 749 09 47
E-mail copyright@iso.org
Web www.iso.org

Published in Switzerland

Contents

Page

Foreword.....	vi
Introduction	vii
1 Scope	1
2 Normative references	1
3 Terms and definitions	2
4 Symbols and abbreviated terms	8
4.1 Symbols	8
4.2 Abbreviated terms	9
5 Conformance.....	10
5.1 Basis for inspection	10
5.2 Repeatability of results	11
5.3 Ordering information	11
6 Quality assurance.....	11
6.1 General.....	11
6.2 Standardization and operating procedures	11
6.3 Equipment description	12
6.4 Personnel qualification	12
6.5 Dynamic test data demonstrating the system capabilities for detecting the reference indicators.....	12
6.6 Reports	12
7 Qualification of inspection personnel	12
7.1 General.....	12
7.2 Written procedure.....	12
7.3 Qualification responsibility and requirements	13
7.4 Training programmes	13
7.5 Examinations.....	13
7.6 Experience.....	13
7.7 Re-qualification	13
7.8 Documentation	14
7.9 NDT personnel certification.....	14
8 General inspection procedures.....	14
8.1 General.....	14
8.2 Owner/operator work site requirements for quality inspection.....	14
8.3 Documents at job site	14
8.4 Pre-inspection procedures	15
8.5 Drill-pipe and tool-joint classification markings	15
8.6 Post-inspection procedures	16
9 General non-destructive inspection method requirements	19
9.1 General.....	19
9.2 Equipment	19
9.3 Illumination.....	20
9.4 Magnetic-particle-inspection equipment.....	21
9.5 Ultrasonic	23
9.6 Electromagnetic inspection units	24
10 Drill stem element inspection and classification	24
10.1 Pipe body — Full-length visual inspection	24
10.2 Drill body — Outside diameter gauging	25

10.3	Pipe body — Ultrasonic wall-thickness gauging	27
10.4	Pipe body — Full-length electromagnetic inspection (EMI)	29
10.5	Pipe body — Full-length ultrasonic transverse and wall thickness	31
10.6	Pipe body — Full-length ultrasonic transverse, wall thickness and longitudinal inspection.....	34
10.7	Drill-pipe body — External magnetic-particle inspection of the critical area	37
10.8	Drill-pipe body — Bi-directional external magnetic-particle inspection of the critical area	40
10.9	Pipe body — Full-length wall-loss inspection.....	43
10.10	Pipe body — Ultrasonic inspection of the critical area.....	46
10.11	Pipe body — Calculation of cross-sectional area.....	49
10.12	Pipe body — Document review (traceability)	50
10.13	Pipe body — Evaluation and classification	50
10.14	Tool joints	55
10.15	Tool joints — Check for box swell and pin stretch.....	60
10.16	Repair of rejected tool joints.....	61
10.17	Tool joints — Check tool-joint pin and box outside diameter and eccentric wear	61
10.18	Tool joints — Measure tool-joint pin and box outside diameter and check for eccentric wear	64
10.19	Tool joints — Check tool-joint pin and box tong space.....	65
10.20	Tool joints — Measure tool-joint pin and box tong space	66
10.21	Tool joint — Magnetic-particle inspection of the pin threads	67
10.22	Tool joint — Magnetic-particle inspection of box threads.....	69
10.23	Tool joints — Measure tool-joint pin inside diameter	70
10.24	Magnetic-particle inspection of the connection OD for heat-check cracking	71
10.25	Bi-directional wet magnetic-particle inspection of the connection OD for heat-check cracking.....	72
10.26	Tool joints — Measure the tool-joint counterbore depth, pin-base length and seal width	76
10.27	BHA connection — Visual inspection of bevels, seals, threads and stress-relief features	77
10.28	BHA — Measure box outside diameter, pin inside diameter, counterbore diameter and benchmark location if a benchmark is present.....	80
10.29	BHA — Check bevel diameter	82
10.30	BHA — Measure bevel diameter.....	83
10.31	BHA — Magnetic-particle inspection of the pin and box threads.....	84
10.32	BHA connection — Liquid-penetrant inspection of the pin and box threads.....	86
10.33	BHA — Dimensional measurement of stress-relief features	88
10.34	Length measurements of the counterbore, pin and pin neck	90
10.35	Drill collar — Visual full-length OD and ID, markings, fish-neck length and tong space	91
10.36	Drill-collar elevator groove and slip-recess magnetic-particle inspection	92
10.37	Drill-collar elevator-groove and slip-recess measurement	95
10.38	Subs (full-length visual OD and ID), fish-neck length, section-change radius and markings ...	96
10.39	Float-bore recess measurements.....	97
10.40	Magnetic-particle inspection of subs — Full-length, internal and external	99
10.41	HWDP — Visual full-length OD and ID, markings and tong space	101
10.42	Visual inspection and wear pattern report for kelly	102
10.43	Magnetic-particle evaluation of critical areas on kellys.....	104
10.44	Magnetic-particle evaluation, full length, of the drive section on kellys.....	104
10.45	Stabilizer (full-length visual OD and ID), fish-neck length, blade condition, ring gauge and markings	104
10.46	Magnetic-particle inspection of the base of stabilizer blades for cracking	106
10.47	Function test.....	108
10.48	Bi-directional, wet magnetic-particle inspection of the base of stabilizer blade for cracking.....	109
10.49	Visual inspection of jars (drilling and fishing), accelerators and shock subs	112
10.50	Maintenance review	113
10.51	Dimensional measurement of wear areas as specified by OEM requirements	113
10.52	Original equipment manufacturer designated testing for used equipment.....	114
10.53	MWD/LWD — Visual, full-length OD and ID, and markings, including visual inspection of hard-banding and coatings	114
10.54	Motors and turbines — Visual, full-length OD and ID and markings, including visual inspection of hard-banding and coatings	116

10.55	Reamers, scrapers, and hole openers — Visual, full-length OD and ID and markings, including visual inspection of hard-banding and coatings.....	117
10.56	Rotary steerable — Visual, full-length OD and ID and markings, including visual inspection of hard-banding	118
10.57	Full-length drift.....	119
10.58	Proprietary equipment inspection	120
10.59	Hard-banding inspection	121
10.60	Transverse magnetic-particle inspection of tool-joint OD and ID under the pin threads	124
10.61	Drill-pipe body — Internal magnetic-particle inspection of the critical area.....	126
10.62	Drill-pipe body — Bi-directional, internal magnetic-particle inspection of the critical area.....	128
10.63	API external upset-thread connection inspection.....	130
Annex A	(normative) Original equipment manufacturer (OEM) requirements	132
Annex B	(normative) Required and additional inspections by product and class of service.....	134
Annex C	(normative) SI units	144
Annex D	(informative) USC units	173
Annex E	(informative) Inspection-level guidelines	202
Annex F	(informative) Proprietary drill stem connection	206
Annex G	(informative) Used work-string tubing proprietary-connection thread inspection.....	211
Bibliography	213

Foreword

ISO (the International Organization for Standardization) is a worldwide federation of national standards bodies (ISO member bodies). The work of preparing International Standards is normally carried out through ISO technical committees. Each member body interested in a subject for which a technical committee has been established has the right to be represented on that committee. International organizations, governmental and non-governmental, in liaison with ISO, also take part in the work. ISO collaborates closely with the International Electrotechnical Commission (IEC) on all matters of electrotechnical standardization.

International Standards are drafted in accordance with the rules given in the ISO/IEC Directives, Part 2.

The main task of technical committees is to prepare International Standards. Draft International Standards adopted by the technical committees are circulated to the member bodies for voting. Publication as an International Standard requires approval by at least 75 % of the member bodies casting a vote.

Attention is drawn to the possibility that some of the elements of this document may be the subject of patent rights. ISO shall not be held responsible for identifying any or all such patent rights.

ISO 10407-2 was prepared by Technical Committee ISO/TC 67, *Materials, equipment and offshore structures for petroleum, petrochemical and natural gas industries*, Subcommittee SC 4, *Drilling and production equipment*.

This first edition of ISO 10407-2, together with ISO 10407-1, replaces ISO 10407:1993, which will be cancelled when both ISO 10407-1 and ISO 10407-2 have been published and which has been technically revised.

ISO 10407 consists of the following parts, under the general title *Petroleum and natural gas industries — Rotary drilling equipment*:

— *Part 2: Inspection and classification of used drill stem elements*

A Part 1, dealing with drill stem design and operating limits, is under development.

Introduction

Users of this International Standard should be aware that further or differing requirements can be needed for individual applications. This International Standard is not intended to inhibit a vendor from offering, or the purchaser from accepting, alternative equipment or engineering solutions for the individual application. This can be particularly applicable where there is innovative or developing technology. Where an alternative is offered, the vendor should identify any variations from this International Standard and provide details.

This International Standard shall become effective on the date printed on the cover but may be used voluntarily from the date of distribution.

This International Standard includes provisions of various natures. These are identified by the use of certain verbal forms:

- SHALL is used to indicate that a provision is MANDATORY;
- SHOULD is used to indicate that a provision is not mandatory, but RECOMMENDED as good practice;
- MAY is used to indicate that a provision is OPTIONAL;
- CAN is used to indicate a POSSIBILITY.

Petroleum and natural gas industries — Rotary drilling equipment —

Part 2: Inspection and classification of used drill stem elements

1 Scope

This part of ISO 10407 specifies the required inspection for each level of inspection (Tables B.1 through B.15) and procedures for the inspection and testing of used drill stem elements. For the purpose of this part of ISO 10407, drill stem elements include drill pipe body, tool joints, rotary-shouldered connections, drill collar, HWDP and the ends of drill stem elements that make up with them. This part of ISO 10407 has been prepared to address the practices and technology commonly used in inspection.

The practices established within this part of ISO 10407 are intended as inspection and/or testing guidance and are not intended to be interpreted to prohibit the agency or owner from using personal judgement, supplementing the inspection with other techniques, extending existing techniques or re-inspecting certain lengths.

This part of ISO 10407 specifies the qualification of inspection personnel, a description of inspection methods and apparatus calibration and standardization procedures for various inspection methods. The evaluation of imperfections and the marking of inspected drill stem elements is included.

This part of ISO 10407 provides the original equipment manufacturers' requirements regarding the minimum information needed for the inspection of their specialized tools in Annex A.

2 Normative references

The following referenced documents are indispensable for the application of this document. For dated references, only the edition cited applies. For undated references, the latest edition of the referenced document (including any amendments) applies.

ISO 10424-1, *Petroleum and natural gas industries — Rotary drilling equipment — Part 1: Rotary drill stem elements*

ISO 11961⁴⁾, *Petroleum and natural gas industries — Steel drill pipe*

API RP 7A1, *Testing of Thread Compound for Rotary Shouldered Connections*

4) To be published. (Revision of ISO 11961:1996, *Petroleum and natural gas industries — Steel pipes for use as drill pipe — Specification*)

3 Terms and definitions

For the purposes of this document, the following terms and definitions apply.

- 3.1**
agency
entity contracted to inspect used drill stem elements using the methods and criteria specified
- 3.2**
A-scan
ultrasonic instrument display where distance is represented on the horizontal axis and signal strength on the vertical axis
- 3.3**
bending-strength ratio
BSR
ratio of the section modulus of the box thread at its last engaged thread to the pin thread at its last engaged thread
- 3.4**
bevel diameter
outer diameter of the contact face of the rotary shouldered connection
- 3.5**
bit sub
sub, usually with two box connections, that is used to connect the bit to the drill stem
- 3.6**
bottleneck sub
sub with two distinct outside diameters
- 3.7**
box end
end of pipe with internal threads
- 3.8**
box thread
internal (female) threads of a rotary shouldered connection
- 3.9**
class 2
second in the hierarchy of used drill pipe service classifications for used drill pipe that does not meet premium class requirements
- 3.10**
class 3
third in the hierarchy of used drill pipe service classifications for used drill pipe that does not meet class 2 requirements
- 3.11**
calibration
adjustment of instruments to a known basic reference often traceable to the national standards body
- NOTE Calibration typically is documented in a log book and by a tag applied to the instrument.
- 3.12**
check
go/no-go determination that dimension is within tolerances

3.13**corrosion**

alteration and degradation of material by its environment

3.14**critical area**

area from the base of the tapered shoulder of the tool joint to a plane located 660 mm (26.0 in) away, or the end of the slip marks, whichever distance is greater

See Figure 4.

NOTE When applied to the work-string tubing area, it is from the end of the pipe to a plane located 508 mm (20 in) away, or the end of the slip marks, whichever distance is greater.

3.15**cut**

incision without removal of metal caused by a sharp object

3.16**dent**

local change in surface contour caused by mechanical impact, but not accompanied by loss of metal

3.17**drift**

cylindrical gauge used to check the minimum inside diameter

3.18**drill collar**

thick-walled pipe or tube designed to provide stiffness and concentration of mass at or near the bit

3.19**drill pipe**

drill pipe body with weld-on tool joints

See Figure 1.

3.20**drill-pipe body**

seamless steel pipe with upset ends

See Figure 1.

3.21**drill stem**

all members between the swivel or top drive and the bit; includes drill string

3.22**drill string**

several sections or joints of drill pipe with the tool joints that are joined together

3.23**failure**

improper performance of a device or equipment that prevents completion of its design function

3.24**fatigue**

process of progressive localized permanent structural change occurring in a material subjected to conditions that produce fluctuating stresses and strains at some point or points and that can culminate in cracks or complete fracture after a sufficient number of fluctuations

3.25

fatigue failure

failure that originates as a result of repeated or fluctuating stresses having maximum values less than the tensile strength of the material

3.26

fatigue crack

crack resulting from fatigue

3.27

filtered FWAC

full-wave current rectified by passing it through a capacitor or other electrical device to remove the fluctuations associated with alternating current

3.28

fish neck

region with a reduced diameter at or near the upper end of a drill string member which fishing tools can grab

3.29

full-depth thread

thread for which the thread root lies on the minor cone of an external thread or lies on the major cone of an internal thread

3.30

gall

surface damage on threads and seals caused by localized friction

3.31

gouge

elongated grooves or cavities caused by mechanical removal of metal

3.32

grind, noun

area where metal was removed with an abrasive wheel in the process of evaluation or repair on an imperfection

3.33

hard-banding

hard-facing

sacrificial or wear-resistant material applied to component's surface to prevent wear of the component

3.34

heat checking

formation of surface cracks formed by the rapid heating and cooling of the component

3.35

heavy-weight drill pipe

HWDP

pipe with thick wall used in the transition zone to minimize fatigue and as bit weight in directional wells

3.36

inspection

process of measuring, examining, testing, gauging or otherwise comparing the product with the applicable requirements

3.37

jar

mechanical or hydraulic device used in the drill stem to deliver an impact load to another component of the drill stem, especially when that component is stuck

3.38**kelly**

square- or hexagonal-shaped steel pipe connecting the swivel to the drill pipe

NOTE The kelly moves through the rotary table and transmits torque to the drill stem.

3.39**label**

dimensionless designation for the pipe body size, pipe body mass per unit length or the size and style of a rotary shouldered connection

3.40**last engaged thread**

last thread on the pin engaged with the box or the box engaged with the pin

See Figure 2.

3.41**lead**

distance parallel to the thread axis from a point on a thread turn and the nearest corresponding point on the next turn, i.e. the axial displacement of a point following the helix one turn around the thread axis

3.42**lower kelly valve****kelly cock**

essentially full-opening valve installed immediately below the kelly, with outside diameter equal to the tool joint outside diameter

NOTE The valve can be closed to remove the kelly under pressure and can be stripped in the hole for snubbing operations.

3.43**make-up shoulder**

sealing shoulder on a rotary shouldered connection

3.44**measure**

determining of dimensional value and recording of it on a worksheet

3.45**mill slot**

flat machined area on the outside diameter of a tool joint where grade, weight code and optional serial number information is stamped

3.46**owner**

company or person who specifies the type of inspection or testing to be conducted and who has the authority to order it performed

3.47**pi tape**

flexible steel tape that, when wrapped around the circumference of a cylinder, indicates the average outside diameter

3.48**pin base**

non-threaded area at the large end of the pin connection adjacent to the shoulder

3.49

pin end

end of the pipe with external threads

3.50

pipe body

seamless steel pipe excluding upset and upset-affected areas

See Figure 1.

3.51

pit

depression resulting from corrosion or removal of foreign material rolled into the surface during manufacture

3.52

pitch

axial distance between successive threads

NOTE In a single start thread, pitch is equivalent to lead.

3.53

premium class

highest in the hierarchy of used drill pipe service classifications, better than class 2 and class 3

3.54

quality programme

established documented system for ensuring quality

3.55

rotary shouldered connection

connection used on drill stem elements that have coarse, tapered threads and sealing shoulders

3.56

seamless pipe

wrought steel tubular product made without a weld seam

3.57

slip area

that part of the pipe body where there is visible evidence of the trip slips having been repeatedly set numerous times in the same area

See Figure 4.

NOTE At the upper end, it is typically located approximately 560 mm (22 in) from the box-tool joint elevator shoulder, and extends from that point approximately 660 mm (26 in) toward the pin end. It can be located elsewhere depending on rig design and positioning of handling equipment. It does not include occasional setting of slips in other areas as a result of fishing operations, drill stem tests and similar applications.

3.58

stabilizer

member of the drill stem assembly used to centralize or control the direction of the bottom-hole assembly

3.59

straight sub

sub with no outside diameter change

3.60

standardization

adjustment of instruments prior to use to an arbitrary reference value

3.61**sub**

short, threaded piece of pipe used to connect parts for the drilling assembly for various reasons, such as crossing over to a different connection, or to save wear and tear on more expensive elements

3.62**thread form**

thread profile in an axial plane for a length of one pitch

3.63**tolerance**

amount of variation permitted

3.64**upper kelly cock**

valve immediately above the kelly that can be closed to confine pressure inside the drill stem

3.65**upset**

forged end of a drill pipe tube used to increase wall thickness

3.66**user**

company or person who employs the equipment

3.67**weight code**

unique numerical code for each outside diameter of drill pipe, normally stamped on the pin base and in the mill slot, which provides wall thickness and pipe body mass per unit length information

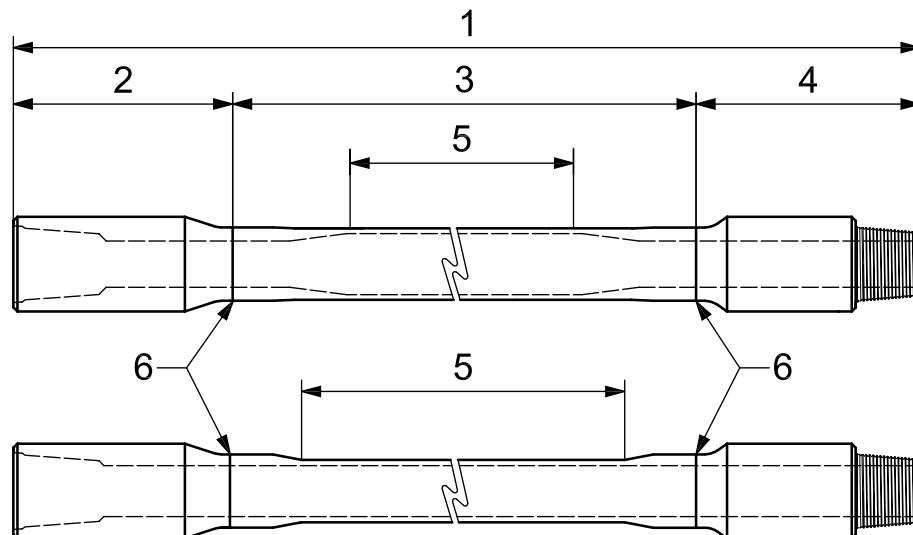
**Key**

1	drill pipe	4	tool joint pin
2	tool joint box	5	pipe body
3	drill pipe body	6	weld

Figure 1 — Drill-pipe nomenclature

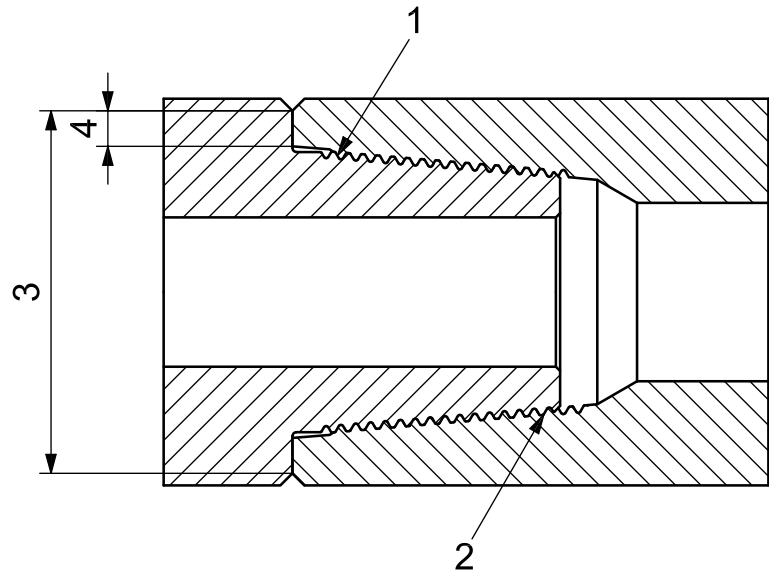

Key

- 1 last engaged thread – pin
- 2 last engaged thread – box
- 3 bevel diameter, D_F
- 4 seal

Figure 2 — Last engaged threads

4 Symbols and abbreviated terms

4.1 Symbols

- A_{CS} cross-sectional area
- D outside diameter
- D_{cb} diameter of counterbore
- D_F bevel diameter
- D_{FR} diameter of float bore recess
- D_L diameter of pin base
- D_{LTorq} diameter of low-torque counterbore
- D_{RG} diameter of stress-relief groove
- D_{tj} outside diameter of tool joint
- d_{tj} inside diameter of tool joint
- l_e elevator groove depth
- l_s slip groove depth
- L_{BC} length of box connection
- L_{br} length of baffle recess
- L_{BT} length from shoulder to non-pressure flank on last full-depth thread box
- L_c minimum-length full-crested threads
- L_{Cyl} length from last scratch to beginning of the tapered section of boreback
- L_{eg} length of elevator groove
- L_{fn} length of fish neck
- L_{PC} length of pin thread
- L_{pb} length of pin base

L_{qc}	length of counterbore
L_R	length float-bore recess
L_{RG}	length of stress-relief groove
L_{sg}	length of slip groove
L_{Tpr}	length of tapered section of boreback
L_X	length from shoulder to last thread scratch in boreback cylinder
Q_c	counterbore diameter
r_{EG}	elevator groove radius
r_{SG}	slip groove radius
S_w	shoulder width
t	average wall thickness

4.2 Abbreviated terms

AC	alternating current
dB	decibels
BHA	bottom-hole assembly
BSR	bending-strength ratio
DC	direct current
EBW	effective beam width
EMI	electromagnetic inspection
EUE	external upset ends
FF	full face
FLUT	full-length ultrasonic transverse
FSH	full screen height
FWAC	full-wave rectified alternating current
HWAC	half-wave alternating current
HWDP	heavy-weight drill pipe
ID	inside diameter
LT	low torque
LWD	logging while drilling
MT	magnetic-particle inspection
MWD	measuring while drilling
NDT	non-destructive testing
NI	ampere turns
OBM	oil-based mud
OD	outside diameter
OEM	original equipment manufacturer
PD	pulse density
PT	liquid penetrant inspection
S/N	signal-to-noise ratio

SOBM	synthetic oil-based mud
SRG	stress-relief groove
SWBM	synthetic water-based mud
TJ	tool joint
TPR	taper
UDP	used drill pipe
UT	ultrasonic inspection
WBM	water-based mud
μW	microwatts

5 Conformance

5.1 Basis for inspection

5.1.1 General

This part of ISO 10407 contains practices for use in the inspection, evaluation and classification of used drill stem elements. Guidelines to assist the user in determining the appropriate level of inspection are provided in Annex E.

The inspections for each level of inspection are shown in Annex B; these practices can be placed in one of the following levels.

- a) Inspections shown under the standard inspection that are specified as mandatory for classification constitute the minimum inspection requirements for classification of the drill stem element.
- b) Inspections that are specified as mandatory for classification when moderate service inspection is specified constitute minimum inspection requirements for classification of the drill stem element according to moderate service inspection requirements.
- c) Inspections that are specified as mandatory for classification when critical service inspection is specified constitute minimum inspection requirements for classification of the drill stem element according to critical service inspection requirements.
- d) Inspections that are not specified as mandatory may be specified based on drilling conditions.

5.1.2 Required inspection tables in Annex B

The tables in Annex B list the required inspections for each of the above levels inspection. The following is a list of drill stem elements covered in the tables in Annex B.

- Table B.1 identifies the inspections available and specifies which inspections are required for each level of inspection for used drill pipe bodies, as well as the additional services available.
- Table B.2 identifies the inspections available and specifies which inspections are required for each level of inspection for used tool joints, as well as the additional services available.
- Table B.3 identifies the inspections available and specifies which inspections are required for each level of inspection for connections used on bottom-hole assemblies, as well as the additional services available.
- Tables B.4 through B.14 identify the inspections available and specify which inspections are required for each level of inspection for bottom-hole-assembly drill stem elements other than connection inspections, as well as the additional services available.
- Table B.15 identifies the inspections available and specifies which inspections are required for each level of inspection for used tubing work strings.

5.2 Repeatability of results

Non-destructive inspection and measurement processes inherently produce some variability of results.

Some of the factors attributable to this variability are as follows:

- a) permissible options in the selection of practices for use in the inspection of specific attributes;
- b) permissible options in the selection of reference standards;
- c) variations in the mechanical and electronic designs used by each equipment manufacturer of non-destructive inspection systems;
- d) lack of exact repeatability within the performance capability of a single non-destructive inspection system set-up.

5.3 Ordering information

In specifying the application of this part of ISO 10407 to an order for the inspection of used drill stem elements, the owner of the equipment should specify the following order information for each size and type of element:

- a) inspection(s) being applied;
- b) reference standard, if applicable;
- c) acceptance criteria;
- d) instructions for marking.

6 Quality assurance

6.1 General

The agency performing field inspection shall implement and maintain a quality programme. The agency's quality-management programme shall be documented and shall include written procedures for all inspections performed, as well as all procedures, control features and documentation.

The agency's quality programme shall address calibration of equipment. The frequency, range, accuracy and procedure for calibration, control features and documentation shall be included.

The agency's quality programme shall include records that verify inspection-system capability for detecting the required reference indicators. The verification of inspection-system capability shall be addressed in accordance with 6.2 through 6.6.

6.2 Standardization and operating procedures

The standardization procedures vary with the different types of equipment. As a minimum, the written procedure should include the minimum reference indicator response and allowed limit for signal-to-noise ratio. The written operating procedures should provide the required steps, control settings and parameter limits, such as the use of special electronic circuits, use of a special detector array and range of velocities being used. Procedures shall be in place to ensure that all equipment and materials employed for testing and examination are used within the temperature and humidity limits established by the manufacturer.

6.3 Equipment description

The equipment used to conduct the inspection should be described in sufficient detail to demonstrate that it meets the requirements.

6.4 Personnel qualification

The agency's quality programme shall include provisions for the education, training and qualification of personnel performing inspections in accordance with this part of ISO 10407.

Documentation of qualification of inspection personnel shall meet the requirements of Clause 7.

6.5 Dynamic test data demonstrating the system capabilities for detecting the reference indicators

There are many methods of verifying system capability, such as the two described in a) and b) below.

- a) Inspection-system capability can be established by using statistical techniques for assessment of inspection performance. By establishing inspection-system set-up parameters and response amplitude of the applicable reference flaws, data points are established to determine the distribution of response amplitudes. These data, then, become the basis for establishing the capability of the inspection system.
- b) Inspection-system capability can also be demonstrated for each inspection order by use of a reference standard with the required reference indicators. After the system is standardized according to the written procedures, the test standard is inspected at a number of positions to establish the reliability in all quadrants.

6.6 Reports

Reports shall include all system settings, signal archival media, traceability of calibration, standardization and set-up procedures and a drawing of the test standard.

7 Qualification of inspection personnel

7.1 General

Clause 7 sets forth the minimum requirements for qualification and certification (where applicable) of personnel performing field inspection of used drill stem elements.

7.2 Written procedure

Agencies performing inspection of used drill stem elements in accordance with this part of ISO 10407 shall have a written procedure for education, training, experience and qualification of personnel.

The written procedure shall establish the following:

- a) administrative duties and responsibilities for execution of the written procedure;
- b) personnel qualification requirements;
- c) required documentation verifying all qualifications.

7.3 Qualification responsibility and requirements

The qualification requirements and qualification of inspection personnel shall be the responsibility of the agency.

The requirements for each applicable qualification shall include the following as a minimum:

- a) training and experience commensurate with the inspector's level of qualification;
- b) written and practical examinations with acceptable grades;
- c) vision examination;
- d) knowledge of this part of ISO 10407 and the related sections of the applicable industry standards.

7.4 Training programmes

All qualified personnel shall have completed a documented training programme designed for that level of qualification. Training may be given by the agency or an outside agent.

The programme shall include the following:

- a) principles of each applicable inspection method;
- b) procedures for each applicable inspection method, including standardization and operation of inspection equipment;
- c) relevant sections of the applicable industry standards.

7.5 Examinations

Examinations may be given by the agency or by an outside agent.

All inspection personnel shall have successfully completed the following examinations:

- a) written examinations addressing the general and specific principles of the applicable inspection method, the inspection procedures and the applicable ISO, API, or ASTM standards;
- b) hands-on or operating examination that shall include apparatus assembly, standardization, inspection techniques, operating procedures, interpretation of results for appropriate levels and related report preparation;
- c) annual vision examination to verify ability, with natural or corrected vision, to read J-2 letters on a Jaeger number 2 test chart at a distance of 305 mm to 381 mm (12 in to 15 in); equivalent tests such as the ability to perceive a Titmus number 8 target, a Snellen fraction 20/25 (0,8), or vision examinations with optical apparatus administered by a qualified medical practitioner are also acceptable.

7.6 Experience

All candidates for qualification shall have the experience required by the written procedure.

7.7 Re-qualification

Re-qualification requirements shall be defined in the written procedure.

Re-qualification is required at least every five years for all personnel.

Re-qualification of personnel is required if an individual has not performed defined functions within the previous twelve months or if an individual changes employers.

As a minimum requirement for re-qualification, all personnel shall

- a) achieve an acceptable grade on a written examination addressing the current applicable inspection procedures and the applicable industry standards, and
- b) provide evidence of continuing satisfactory technical performance.

7.8 Documentation

Record retention and documentation shall be required for all qualification programmes.

The minimum requirement is the retention of the following documents:

- a) records of all qualified personnel showing training-programme completion and experience;
- b) examinations results, which shall be maintained by the agency and made available for review upon request;
- c) records for each qualified individual, which shall be retained for a minimum of one year after the revocation date of the qualification.

All qualifications and related documents shall be approved by authorized agency personnel.

7.9 NDT personnel certification

A programme for certification of NDT personnel shall be developed by the agency. ISO 11484 may be used as a guideline.

NOTE For the purposes of this recommendation, ASNT SNT-TC-1A is equivalent to ISO 11484.

The administration of the NDT personnel-certification programme shall be the responsibility of the agency.

8 General inspection procedures

8.1 General

Clause 8 covers the general procedures applicable to all inspection methods contained in this part of ISO 10407.

8.2 Owner/operator work site requirements for quality inspection

The owner/operator shall provide a site, or deliver the items for inspection to a site, where they can be inspected on racks or tables with a height suitable for inspection. The pipe, collars and other tubular products shall be stored in a single layer with sufficient space that they can be rolled one complete revolution during the inspection process. Failure to meet these requirements does not allow inspection quality consistent with the intent of this part of ISO 10407.

Thread protectors shall be provided.

8.3 Documents at job site

Agency-controlled inspection documents related to the job and relevant reference documents shall be available at the job site. Additional documentation of inspector certifications shall be available.

8.4 Pre-inspection procedures

8.4.1 Equipment availability

Each inspection shall start with the correct equipment available and in good working condition.

8.4.2 Description comparison

Prior to equipment set-up, the agency shall assure that the drill stem element(s) for inspection is/are the drill stem element(s) the owner has ordered inspected by comparing the information on the job order with the drill stem element markings, i.e. labels, size, ID, weight code, grade, manufacturer, features and connection.

8.4.3 Numbering or recording

All inspection should be traceable to the specific item by uniquely numbering or recording permanent serial numbers for each length inspected. For drill pipe, this number is die-stamped on the 35° (or 18° where provided) shoulder of the pin-end tool joint.

After some period of use, many drill strings are made up of replacement or added lengths. For that reason, the serial numbering for the most recent inspection should be added to the taper shoulder along with the numbers from previous inspections. Each series of numbers shall be accompanied by a means to identify the inspection classification and which was the most recently applied (see Figure 3). This is typically done by adding punch marks to denote classification and numbers denoting the month and year in which the inspection is performed and the agency mark. Inspection punch marks and classification bands shall be added only after completion of all required inspections.

Some drill-string elements, including drill pipe, receive a permanent serial number affixed by the manufacturer or by the owner. By agreement between the owner and inspection agency, the permanent identification system (where available and legible) may be used in place of the regular serial numbering process. Also by agreement with the owner, any element found without an available or legible serial number shall be given a number.

Care should be exercised to avoid placing new serial numbers over the same area occupied by previous numbers. Serial numbers shall be applied to areas where wear and other damage to the numbers is minimized and in a low-stress section of the element.

8.4.4 Cause downgrade

The inspection of each drill-string element shall require that all procedures necessary for that category be completed before the element is given a classification. There can be instances where conditions, such as cracks, holes, or unrepairable conditions, are detected before the required procedures are completed. Termination of the inspection at the point where the rejectable condition is detected should be a matter of discussion and agreement between the element owner and the inspection agency.

8.5 Drill-pipe and tool-joint classification markings

8.5.1 Permanent mark or marks

A permanent mark or marks signifying the classification of the pipe shall be stamped as follows:

- a) on the 35° or 18° sloping shoulder of the pin-end tool joint (see Figure 3);
- b) in some other low-stress section of the tool joint where the marking can normally carry through operations;

Cold steel stamping should be avoided on the outer surface of the tube body.

One centre punch denotes "premium", two denote "class 2", three denote "class 3" and four denote scrap.

8.5.2 Paint band marking

Paint-band marking signifying the drill-pipe and tool-joint condition shall be applied as follows.

- a) If the tool joint is in the same class or better, markings are required only on the tube.
- b) If the tool joint is in a class lower than the tube tool-joint classification, markings are required in the tool joint.
- c) Tool joints requiring repair to the threads and seal shall be marked according to Figure 3.

8.6 Post-inspection procedures

8.6.1 Classification

Each length of pipe, tool joint, and bottom-hole assembly component shall be classified according to the requirements in Clause 10.

8.6.2 Cleaning

Remove all magnetic particles, liquid-penetrant developer and cleaning material from the connections.

8.6.3 Count lengths

Count the lengths in each of the classification categories. Verify the totals after the initial count.

8.6.4 Thread protection

After inspection, ensure that the threads are clean and dry. Coat the threads with a rotary shoulder thread compound manufactured in accordance with API RP 7A1 or as specified by the owner/operator. Coat the full threaded area, including shoulders and thread roots, for the full thread circumference. In very cold climates, it can be necessary to warm the thread compound in order to apply it. Thread compounds shall not be thinned with solvent. Reinstall clean thread protectors if available. Tighten thread protectors wrench-tight.

CAUTION — The material safety data sheets for thread compounds should be read and observed. Store and dispose of containers and unused compound in accordance with appropriate regulations.

8.6.5 Job-site checklist

Before leaving the job site, the agency shall ensure that the following items have been accomplished.

- a) Pipe racking: The agency shall ensure that each row of pipe has been properly secured and that no loose or unsecured pipe is left free to roll or fall from the racks. Pipe should not be left on the ground.
- b) Debris removal: The job site shall be left neatly arranged and clean of all job-related debris.
- c) Solvent disposal: Cleaning solvents used at the job site shall be disposed of properly.

DANGER — Solvents, other cleaning agents, scale and other generated waste can contain hazardous materials. When applicable, material safety data sheets should be read and the precautions observed when handling products of this type. Storage, transport, use and disposal of generated waste materials and containers should be considered. Observe appropriate regulations relative to disposal of used solvents and generated waste materials.

8.6.6 Inspection markings

8.6.6.1 General

In 8.6.6 the practice for the uniform inspection marking of used drill stem elements is set forth.

8.6.6.2 Authority

The classification of each inspected length shall be performed only by a qualified inspector. However, any crew member may be directed to apply the appropriate descriptions, stencils and paint bands.

8.6.6.3 Drill pipe

8.6.6.3.1 Sequence number

Each length of inspected drill pipe shall have a unique number stamped on the 35° sloping pin tool-joint shoulder. The sequence number shall be preceded by the month and year of inspection, the classification stamp and name or mark of the company doing the inspection (see Figure 3, item 3). Stamps shall be no larger than 10 mm (3/8 in). The sequence number stamp is not required if serial numbers are used for traceability, but all the other information stamps shall be applied. The classification stamp shall be applied only after all required inspections have been completed and shall reflect the lowest classification for the tube and tool joints.

8.6.6.3.2 Paint bands

8.6.6.3.2.1 Pipe body

Each length shall receive pipe-body classification paint-band markings based on the requirements of Table B.18 for used drill pipe or Table B.19 for used work-string tubing. Paint bands shall be placed approximately 0,5 m (18 in) from the 35° sloping pin shoulder. Paint bands shall be approximately 51 mm (2 in) wide.

All downgraded pipe shall have a 25 mm (1 in) band around the tube in the defective area and the defective area shall be boxed in. The colour of the band shall reflect the downgrade classification of the defect. The reason for rejection shall be written next to the band with a paint marker or other indelible marker.

8.6.6.3.2.2 Downgraded tool joints

Each tool joint that does not meet the minimum outside diameter, inside diameter or shoulder width requirements in Table C.6 (Table D.6) shall receive a paint band in the centre of the tool joint. This paint band indicates that the tool joint does not have torsional strength that is at least 80 % of the required pipe-body torsional strength.

8.6.6.3.2.3 Tool-joint condition

All damaged tool-joint connections that require shop repair shall have a 25 mm (1 in) red band painted on the outside diameter of the connection adjacent to the sealing shoulder (see Figure 3). The reason for rejection shall be written on the part next to the red paint band with a paint marker or other means durable enough to endure through repair operations. These markings shall be removed after repair.

All field-repairable connections not repaired at the time of inspection repair shall have a 25 mm (1 in) green band painted on the outside diameter of the connection adjacent to the sealing shoulder (see Figure 3). The reason for rejection shall be written on the part next to the green paint band with a permanent marker. These markings shall be removed after repair.

8.6.6.3.2.4 Optional paint marking

A paint marking containing additional information may be placed on the tube body adjacent to the classification band(s). Optional paint markings may be used to identify the agency, the work order number, the inspection level, any optional inspections performed and the date (month and year) of the inspection. Lettering shall be at least 25 mm (1 in) high.

Paint stencil markings for landing strings shall include the minimum remaining wall used as the basis for acceptance.

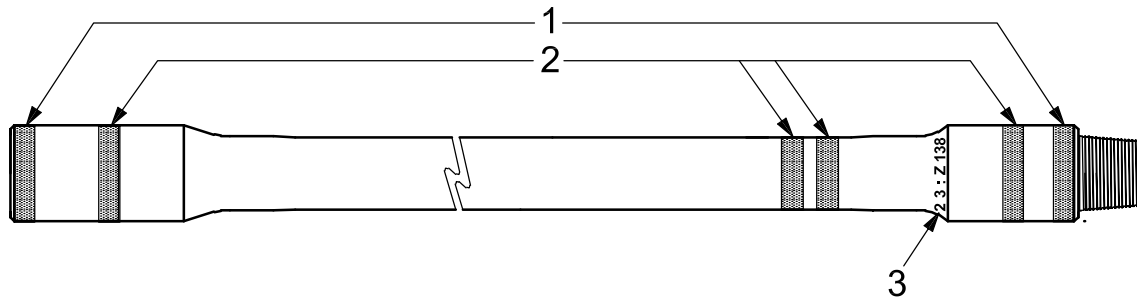

Key

- 1 tool-joint condition bands
- 2 classification paint bands for drill pipe and tool joints
- 3 stencil/stamp for permanent marking for classification of drill-pipe body as follows:

Tool-joint and drill-pipe classification	Number and colour of bands	Tool-joint condition	Colour of bands
Premium class	Two white	Scrap or shop repair	Red
Class 2	One yellow	Field repairable	Green
Class 3	One orange	—	—
Scrap	One red	—	—

Figure 3 — Drill-pipe and tool-joint colour code identification

8.6.6.4 Drill collars and other bottom-hole assembly drill stem elements

8.6.6.4.1 White paint markings

As near as possible to the pin shoulder, paint markings shall identify the agency, the work-order number, inspection and level, any optional inspections performed and the date (month and year) of the inspection.

8.6.6.4.2 Paint bands

8.6.6.4.2.1 BHA component body

Each acceptable BHA component shall receive a white classification paint band. Paint bands shall be placed approximately 152 mm (6 in) from the pin shoulder.

Each cracked or scrap part shall have a red paint band painted around the defective area. The reason for rejection shall be written on the part next to the red paint band with a permanent marker.

8.6.6.4.2.2 Connection condition

All damaged connections that require shop repair shall have a 25 mm (1 in) red band painted on the outside diameter of the connection adjacent to the sealing shoulder. The reason for rejection shall be written on the part next to the red paint band with a permanent marker. These markings shall be removed after repair.

All field-repairable connections not repaired at the time of inspection repair shall have a 25 mm (1 in) green band painted on the outside diameter of the connection adjacent to the sealing shoulder. The reason for rejection shall be written on the part next to the green paint band with a permanent marker. These markings shall be removed after repair.

8.6.7 Documentation — On-site inspection summaries

On-site inspection summaries for BHA elements shall include

- description of the part inspected,
- serial number of the part inspected,
- type of inspection performed,
- results of inspection,
- date of inspection, and
- description of all conditions causing rejection of a part.

9 General non-destructive inspection method requirements

9.1 General

Clause 9 provides descriptions of, and capability requirements for, inspection tools required for inspection of used drill pipe and bottom-hole assembly equipment.

9.2 Equipment

9.2.1 General

These requirements shall be applicable to equipment used for visual and dimensional inspection of used drill stem elements.

9.2.2 Precision callipers (micrometer, vernier or dial)

The instrument shall be calibrated in accordance with the agency's quality programme. The calibration check shall be recorded on the calliper and in a log with the date of the calibration check, the due date and the initials of the person who performed the check.

9.2.3 Non-adjustable length- and diameter-measuring devices

Length- and diameter-measuring devices consist of steel rules, steel length or diameter measuring tapes and other non-adjustable measuring devices.

Accuracy verification shall be defined in the agency's quality programme.

9.2.4 Depth gauges

The instrument shall be calibrated in accordance with the agency's quality programme. The calibration check shall be recorded on the calliper and in a log with the date of the calibration check, the due date and the initials of the person who performed the check.

9.3 Illumination

9.3.1 External surface illumination

9.3.1.1 Direct daylight

Direct daylight conditions do not require a check for surface illumination.

9.3.1.2 Night and enclosed-facility illumination

The diffused-light level at the surfaces being inspected shall be a minimum of 538 lx (50 ft-candles).

Illumination in enclosed, fixed-location facilities shall be in accordance with the agency's quality programme. The check shall be recorded in a log with the date, the reading and the initials of the person who performed the check. This record should be available on site.

9.3.1.3 Night illumination with portable equipment

The diffused-light level at the surfaces being inspected shall be a minimum of 538 lx (50 ft-candles).

Proper illumination shall be verified at the beginning of the job to assure that portable lighting is directed effectively at the surfaces being inspected. Illumination shall be checked during the job whenever lighting fixtures change positions or intensity relative to the surfaces being inspected.

Light meters used to verify illumination shall be calibrated in accordance with the agency's quality programme. The calibration check shall be recorded on the meter and in a log with the date of the calibration check, the due date and the initials of the person who performed the check.

9.3.2 Internal surface illumination

9.3.2.1 Mirrors for illumination

The reflecting surface shall be a non-tinted mirror that provides a non-distorted image. The reflecting surface shall be flat and clean.

9.3.2.2 Portable lights

A portable light producing an intensity greater than 1 076 lx (100 ft-candles) at the maximum inspection distance may be used for illumination of inside surfaces.

9.3.2.3 Other light sources

A light source having documented, demonstrated capability may be used for illumination of inside surfaces. The lens of the light source shall be kept clean.

9.3.2.4 Optical inspection equipment

The resolution of the borescope, video or other optical internal inspection device shall be checked at the start of a job and whenever all or part of the equipment is assembled during a job. The date on a coin [not to

exceed 1,0 mm (0.040 in) in height] or, as an alternative, Jaeger J-4 letters placed within 102 mm (4.0 in) of the objective lens, shall be readable through the assembled optical inspection device.

9.4 Magnetic-particle-inspection equipment

9.4.1 Magnetizing current power supplies

Magnetizing current power supplies shall have an ampere meter. Ammeters (reading magnetizing current) shall be calibrated in accordance with the agency's quality programme. The calibration shall be recorded on the instrument and in a log and shall specify the date of the calibration, due date and the initials of the person performing the calibration.

9.4.2 Coils

A longitudinal magnetic field is induced by placing a coil around the product and applying a current. The number of turns of the coil shall be clearly marked on the coil.

Coils shall be checked to verify the integrity of the internal wire turns in accordance with the agency's quality programme. Typically, this is done by comparing the resistance or magnetic flux values to those initially established when the coil was new.

The verification check shall be recorded in a log with the date of the calibration check, the due date and the initials of the person who performed the check.

9.4.3 Internal conductor

A circumferential magnetic field is induced by inserting an insulated conductor inside the product, completing the circuit to the power supply and energizing the circuit with the appropriate current as given in Table C.2 (Table D.2). An audible or visible annunciator may be used in addition to the ampere meter to indicate inadequate current.

The conductor shall be insulated from the product surface to prevent electrical contact or arcing.

9.4.4 Yokes

Yokes are hand-held magnetizing devices used to detect imperfections in any orientation on the same surface to which the yoke is applied. Yokes have either fixed or articulated legs and may be energized by either alternating or direct current. For some applications, adjustable legs are preferred for inspection of curved surfaces because the legs can be adjusted to maintain contact on the inspection surface, regardless of contour.

AC-energized yokes shall be capable of lifting 4,5 kg (10.0 lbs) at the maximum pole spacing that can be used for inspection.

DC-energized yokes shall be capable of lifting 18 kg (40 lbs) at the maximum pole spacing that can be used for inspection.

Yokes normally are tested for lifting power using a steel bar or plate of the appropriate mass or a calibrated magnetic-mass lift-test bar. Frequency and procedures for the conduction lift test shall be in accordance with the agency's quality programme. The calibration check shall be recorded on the yoke and in a log with the date of the calibration check, the due date and the initials of the person who performed the check.

9.4.5 Ground-fault interrupter circuits

When using coils or yokes with active wet magnetic-particle inspection, the power circuit should include a ground-fault interrupter.

9.4.6 Magnetic particle field indicators

Acceptable field indicators (e.g. slotted shims, strips, pie field indicators) should be able to hold magnetic particles in a field of approximately 5 Gs. Magnetic-particle field indicators are limited to indicating the presence of an external magnetic field, that is, with the flux lines in air rather than in the material.

9.4.7 Magnetometers and gauss meters

9.4.7.1 General

Magnetometers and gauss meters are used to indicate the relative strength of the external magnetic field. Both types of instrument are limited to measuring the external magnetic fields but work well to demonstrate similar magnetic-field strength. If the magnetic field indicates the same on two pipe ends when the field strength indicator is placed at the same position on both, it can be concluded that the magnetic fields in both pipe are about the same.

9.4.7.2 Gauss meters

Gauss meters that are used to verify relative magnetic field strength shall be calibrated in accordance with the agency's quality programme. The calibration check shall be recorded on the meter and in a log with the date of the calibration check, the due date and the initials of the person who performed the check.

9.4.7.3 Magnetometers

Magnetometers shall be tested for accuracy in accordance with the agency's quality programme. The calibration check shall be recorded on the magnetometer and in a log with the date of the calibration check, the due date and the initials of the person who performed the check.

9.4.8 Magnetic particles

9.4.8.1 General

Magnetic particles are used to indicate imperfections that cause magnetic-flux leakage. Particles may be applied either dry or in suspension (wet).

9.4.8.2 Dry magnetic particles

Dry magnetic particles shall contrast with the product surface and shall not be reused. The mixture shall consist of particles of different sizes with at least 75 % mass fraction being finer than 150 µm and a minimum of 15 % mass fraction finer 45 µm. The particle mixture shall not contain contaminants such as moisture, dirt, sand, etc. As a supplementary practice, there may be a particle manufacturer's batch or lot check of particles for high permeability and low retentivity.

9.4.8.3 Wet fluorescent magnetic particles

Fluorescent magnetic particles are suspended in a solution. The solution shall be low-viscosity (5 cSt or less), non-fluorescent, with a flash point above 93 °C (200 °F) and able to wet the surface completely. Particles shall glow when exposed to ultraviolet light. Wet fluorescent particles shall be applied by low-velocity flow to prevent washing away weakly held indications. Recirculating systems, spray containers or other means shall be used to obtain proper application.

The solution shall be mixed according to the manufacturer's instructions and agitated either continuously or periodically. Concentration shall be between 0,1 % volume fraction and 0,4 % volume fraction. Settling test time is 1 h for oil-based carriers and 30 min for water-based. Settling tests shall be done in a vibration-free, non-magnetic environment. A manufacturer's lot test may be used in lieu of the settling test for particles provided in aerosol containers.

The concentration of the solution shall be checked prior to use. The concentration of the solution in recirculating systems shall be verified at least once during each shift.

9.4.8.4 Black magnetic particle and white background

White background coating shall be supplied by the wet black-particle manufacturer or designated as compatible with the particles by the particle manufacturer. Total coating thickness from all forms of coatings at the time of inspection shall not exceed 0,05 mm (0.002 in). Black particles are suspended in a solution. The solution shall be of low viscosity (5 cSt or less), with a flash point above 93 °C (200 °F) and able to wet the surface completely. Particles shall be applied by low-velocity flow to prevent washing away weakly held indications. Recirculating systems, spray containers or other means shall be used to obtain proper application.

9.4.8.5 Ultraviolet light

Ultraviolet light is employed to illuminate the accumulation of fluorescent-dyed magnetic particles. An appropriately filtered mercury arc lamp or other source should provide ultraviolet light. It shall be capable of providing wavelengths at or near 365 nm and a minimum intensity of 1 000 $\mu\text{W}/\text{cm}^2$ at the inspection surface under working conditions. Intensity should be measured with the ultraviolet light sensor on the inspection surface and directed toward the ultraviolet light source. The ambient visible light intensity during ultraviolet light inspection, measured at the inspection surface, shall not exceed 21,5 lx (2 ft-candles).

Meters used to verify ultraviolet or visible illumination shall be calibrated in accordance with the agency's quality programme. The calibration check shall be recorded on the meter and in a log with the date of the calibration check, the due date, and the initials of the person who performed the check.

9.5 Ultrasonic

9.5.1 Thickness gauges

9.5.1.1 Gauge linearity

The linearity of the gauge's readout shall be calibrated in accordance with the agency's quality programme. The calibration shall be recorded on the instrument and in a log and shall specify the date of the calibration, due date and the initials of the person performing the calibration.

9.5.1.2 Sensitivity check

If the ultrasonic gauge is used to evaluate the remaining wall above an internal surface imperfection, the ultrasonic-gauge-transducer combination shall be able to detect a 0,79 mm (0.031 in) flat-bottomed hole at least 9,7 mm (0.38 in) from the front surface of a parallel surface test block. The remaining wall thickness measurement accuracy shall be $\pm 0,25$ mm (± 0.010 in). Verification of this capability may be part of the agency's periodic calibration. If this check is performed at the time of calibration, it shall be noted in the calibration records.

9.5.2 Ultrasonic flaw-detector units

Instrument controls of the flaw-detector units shall be calibrated in accordance with the agency's quality programme.

If a recorder display is used, the linearity of its scale shall also be calibrated in accordance with the agency's quality programme.

Instrument readouts for determining rotational speed and linear or inspection-mechanism speed if used to monitor coverage shall also be calibrated in accordance with the agency's quality programme.

The calibration shall be recorded on the A-scan display instrument or recorder and in a log and shall specify the date of calibration, the due date and the initials of the person performing the calibration.

9.6 Electromagnetic inspection units

9.6.1 Ammeters

Ammeters (reading magnetizing current) shall be calibrated in accordance with the agency's quality programme. The calibration shall be recorded on the ammeter. A log shall be maintained to record the calibration of the ammeter, coil and reference standards, and shall specify the date of the calibration, due date and the initials of the person performing the calibration.

9.6.2 Coils

Coils shall be checked to verify the integrity of the internal wire turns in accordance with the agency's quality programme. Typically, this is done by comparing resistance or magnetic flux values to those initially established when the coil was new.

The verification check shall be recorded in a log with the date of the calibration check, the due date and the initials of the person who performed the check.

9.6.3 Rotational and linear speed instruments

Instrument readouts for determining rotational speed and linear or inspection-mechanism speed if used to monitor coverage shall also be calibrated in accordance with the agency's quality programme.

9.6.4 EMI reference standards

The response of each reference indicator for reference standards with more than one reference indicator shall be similar (average indication $\pm 10\%$) and shall be verified at the time of manufacture and at least once every 2 years thereafter.

10 Drill stem element inspection and classification

10.1 Pipe body — Full-length visual inspection

10.1.1 Description

A full-length visual inspection of the entire outside surface from upset to upset (see Figure 1, pipe body) shall be conducted to detect gouges, cuts, pits, dents, crushing, necking, string shot, grinds, bent pipe and other visually detectable imperfections. Internal surfaces shall be examined from each end to detect pits, erosion, and wireline cuts. An evaluation of the condition of the internal coating, if present, shall also be made.

10.1.2 Preparation

Areas inspected shall be clean and free from all dirt, thread dope, grease, rust, loose paint, lint and other types of foreign material that can limit and interfere with the inspection process and accuracy.

10.1.3 Equipment

A non-permanent marker, such as chalk, may be used to identify areas requiring evaluation or that can cause indications on the electromagnetic inspection. An illumination source meeting the requirements of 9.3 is required.

10.1.4 Illumination

External illumination shall meet the requirements of 9.3.

10.1.5 Inspection procedure

Each pipe shall be visually inspected for imperfections on the entire outside surface. This inspection may be done as a separate inspection or in conjunction with OD gauging (see 10.2). Rolling each length and viewing the entire surface is required. Inspect for visually detectable imperfections.

While illuminating the inside surface, visually examine the internal surface from each end, noting any visually detectable imperfections and the condition of the internal coating.

10.1.6 Evaluation procedures

All external imperfections shall be marked with non-permanent markings to allow easy and quick correlation when it is detected by the electronic inspection.

Imperfections detected that can affect the classification shall be marked and evaluated according to 10.13, based on the type of imperfection.

The condition of the internal coating shall be reported as an estimate of the percent missing or not bonded to the pipe. The condition of the internal coating is not used to classify the pipe.

NOTE The condition of the internal coating does not affect the operating limits of the drill pipe and, therefore, is not included in the classification criteria. Conditions are reported to the owner for information purposes.

Pipe that is bent or bowed more than 76 mm (3.0 in) over the entire length or 12,7 mm (0.5 in) in the first 1,5 m (5,0 ft) from either end shall not be inspected. All lengths that have been straightened shall be inspected after straightening.

Pipe shall not be inspected with drill-pipe rubbers installed.

10.2 Drill body — Outside diameter gauging

10.2.1 Description

The full length of each length shall be checked from upset to upset with an OD gauge to identify diameter reductions. The pipe shall be rolled as the OD gauge is dragged or stabbed along the surface. For each interval of 1,5 m (5.0 ft) of pipe inspected, the pipe shall be rolled a full 360°. Measurement of OD by laser, a vision system or other techniques is acceptable as long as the minimum requirements in 10.2 are met.

10.2.2 Equipment

The typical OD gauge is a go/no-go tool that is used to locate reductions of the pipe outside diameter. The OD gauge detection anvils are set 0,79 mm (0.031 in) smaller than the specified pipe outside diameter [see Tables C.4 or C.5 (Tables D.4 or D.5)]. If the gauge does not fit over the pipe, the diameter reduction is less than 0,79 mm (0.031 in). This tool provides a quick method of scanning the pipe to locate areas where the OD is reduced by 0,79 mm (0.031 in) or more. A calliper is required to measure the length of the standardization bar.

10.2.3 Surface conditions

The outside diameter of the drill-pipe body shall be cleaned to remove scale, mud, etc. Cleaning is done only as required to properly perform the OD gauging.

10.2.4 Standardization

10.2.4.1 General

Using callipers, verify that the standardization bar length is $0,79 \text{ mm} \pm 0,13 \text{ mm}$ ($0.031 \text{ in} \pm 0.005 \text{ in}$) less than the pipe specified outside diameter [see Tables C.4 or C.5 (Tables D.4 or D.5)]. Using the standardization bar, check and adjust the anvils if necessary. The anvils shall be parallel and the standardization bar fit snugly at both ends of the anvil. Ensure that all screws are tight. Adjust the wire indicator, if provided, by placing the standardization bar over the plunger and setting the indicator to the appropriate setting.

10.2.4.2 Frequency of standardization

General standardization of inspection equipment shall be performed at the beginning of each job.

Periodic standardization checks shall be performed as follows:

- a) at the beginning of each inspection shift and after each break;
- b) at least once per hour of continuous operation or every 25 lengths inspected, whichever occurs first;
- c) whenever there is a change in operator (inspector);
- d) when the OD gauge is subjected to abnormal mechanical shock;
- e) prior to breaks during a job;
- f) prior to resuming operation after repair or adjustments;
- g) prior to equipment shutdown at the end of the job.

10.2.4.3 Unacceptable checks

All pipe inspected between an unacceptable check and the most recent acceptable check shall be re-inspected.

10.2.5 Inspection procedures

Each length of pipe body shall be OD-gauged along the full length (upset to upset). The pipe shall be rolled at least 180° every 0,8 m (2.5 ft) of gauging. Ensure that all anvils of the OD gauge stay tight during the job (see 10.2.2).

When the gauge goes over the outside diameter of the pipe, the anvil opposite the plunger shall be held firmly against the pipe surface prior to reading the indicator. The pipe shall be rotated a full 180° to search for the maximum reading. Search along the pipe axis on either side of the initial location to find the maximum outside diameter reduction.

Mark the area or spot of maximum outside diameter reduction by placing an "X" next to each parallel anvil. Determine whether the reduction is due to wear or to mechanical deformation (stress-induced).

10.2.6 Wear

If the outside diameter reduction is due to wear, the evaluation for classification shall be based on the remaining wall thickness as specified in 10.13.5.

10.2.7 Stress-induced diameter reductions or increases

If the outside diameter reduction is stress-induced (crushing, necking, dents or mashes), it shall be evaluated in accordance with the procedures for stress-induced diameter reduction in 10.13.6.

If an outside diameter increase is detected (string shot), it shall be evaluated in accordance with procedures for stress-induced diameter increases in 10.13.7.

10.3 Pipe body — Ultrasonic wall-thickness gauging

10.3.1 Description

These procedures are used to perform manual ultrasonic wall-thickness measurements to determine the minimum wall in the centre of the pipe or at the point where the OD gauge or other instruments indicate a wall reduction. On drill pipe, this test is normally performed at one location but may be performed at additional locations.

10.3.2 Equipment

10.3.2.1 Ultrasonic thickness gauge

The ultrasonic thickness gauge is used to measure the wall thickness from the outside surface. The gauge typically consists of an ultrasonic transducer, a connecting cable and a battery-powered instrument package with a digital, scope or meter readout. The transducer shall be a dual element and the diameter shall not exceed 9,53 mm (0.375 in). It shall be capable of reading the thickness of a parallel-surface test block within $\pm 0,025$ mm (± 0.001 in) of the actual thickness. If used to measure remaining wall above an internal imperfection, it shall meet the sensitivity requirements of 9.5.1.2.

10.3.2.2 Couplant

A couplant shall be used to wet the surface of the pipe and provide transmission of ultrasound from the transducers into the pipe being tested. It shall be free of contaminants that can interfere with the sensitivity of the inspection or the interpretation of the readout. Rust inhibitors, water softeners, glycerine, antifreeze or wetting agents may be added to the couplant provided they are not detrimental to the pipe surface. The couplant shall be of sufficient viscosity to provide an air-free interface without the necessity of applying excessive pressure on the transducer.

10.3.3 Surface conditions

Surfaces in the area of transducer placement shall be clean and free of loose scale, dirt, grease or any other material that can interfere with a proper zero on the pipe surface, the sensitivity of the inspection or the interpretation of the readout.

10.3.4 Calibration

Ultrasonic thickness gauges shall be calibrated as required in 9.5.1.

10.3.5 Standardization

10.3.5.1 General

If the readout does not remain stable when the transducer is being held securely on the test block, the gauge is malfunctioning. It shall be repaired or replaced prior to standardization or inspection.

All standards used for standardization shall have velocity and attenuation properties similar to the material being inspected. Prior to use, to minimize error due to temperature differences, the standard(s) shall be exposed to the same ambient temperature as the material for 30 min or more. Placement of the standard on the pipe surface and maximizing its contact area can shorten the exposure time to 10 min.

The parting line between the transmitting and receiving transducer shall be perpendicular to the standard or pipe axis. When the parting line of a dual-element transducer is applied at an angle less than perpendicular

with the longitudinal axis, the resulting ultrasonic readings can be greater than the actual pipe thickness. The smaller the pipe diameter, the larger the error.

Reference standards shall have the same outside surface curvature as the specified outside diameter of the material being measured, except that a flat standard can be used on pipe with specified diameters larger than 88,93 mm (3 1/2 in).

All gauges shall be standardized according to the gauge manufacturer's instructions on a standard thickness that is at least 1,27 mm (0.050 in) thinner than the minimum wall thickness for class 2 and on a second standard thickness that is at least 1,27 mm (0.050 in) thicker than the specified wall thickness of the material being inspected. The thickness of the standard shall have been verified by micrometer measurement. The gauge accuracy shall be within $\pm 0,025$ mm (± 0.001 in) of the standard's thickness on both of the required thickness steps.

When standardizing on reference standards not having the same specified outside surface curvature as the specified outside diameter of the material being measured, the ultrasonic zero shall also be verified on a known thickness curved piece, such as the EMI reference standard.

A concave transducer face causes pipe wall to appear thinner than the actual value when the ultrasonic gauge is standardized on a thickness standard with a greater radius of curvature than the material being inspected. A concave transducer face causes the pipe wall to appear thicker than the actual value when the ultrasonic gauge is standardized on a thickness standard with a smaller radius of curvature than the material being inspected. Because of wear, grinding and other diameter variations, it is important to have the transducer face flat. The transducer shall be checked for wear prior to the start of inspection by comparing accuracy on a curved reference standard and a flat reference standard with the same velocity. If there is no transducer wear, the readings are accurate on both standards. Transducers with a worn face shall be replaced.

10.3.5.2 Frequency of standardization

Periodic standardization checks shall be performed as follows:

- a) at the beginning of each inspection shift;
- b) at least every 25 areas measured or inspected in a continuous operation;
- c) after any power interruption or change in power supply (battery to charger);
- d) whenever there is a change of operator (inspector);
- e) prior to equipment shutdown during a job;
- f) prior to resuming operation after repair or change to a system component that can affect the system performance;
- g) whenever the transducer, cable or type of couplant is changed;
- h) prior to turning the gauge off at the end of the job;
- i) whenever a reading is encountered which is within 0,25 mm (0.010 in) of the minimum permissible remaining wall thickness prior to downgrade.

10.3.5.3 Unacceptable checks

The gauge reading during a standardization check shall be readjusted when there is a variance of more than 0,05 mm (0.002 in) from the original standardization value. All drill pipe inspected between an unacceptable check and the most recent acceptable check shall be re-inspected.

10.3.6 Manual ultrasonic thickness-gauging procedure

A sufficient number of wall-thickness measurements shall be taken around the pipe to locate the minimum wall thickness in the areas of wall reduction as indicated by the OD gauge or other inspection. In the absence of such indication, the wall measurement to locate the minimum wall shall be taken approximately in the centre of the drill-pipe tube.

In each area being measured, remove all dirt and loose material that can interfere with the accuracy of the wall-thickness measurement from the external surface and apply a couplant.

For each measurement, allow the reading to stabilize, then compare the reading with the minimum allowable wall thickness. A stable reading is one that maintains the same value $\pm 0,025$ mm (± 0.001 in) for at least 3 s.

When using a highly sensitive gauge, care shall be taken to ensure that detection of an inclusion or lamination is not interpreted as a reduction in wall thickness. Inclusions and laminations shall not be used for classification.

When a borderline reading is encountered, conduct a search around the site of the low reading to detect further reduction. Repeat the search with subsequent low readings until the pipe can be classified.

When a reading is made that can downgrade the material, check the surface condition and scrape loose scale to clean the surface without removing any base metal. Verify the gauge standardization and re-check the thickness measurement. The final reading shall be used to classify the pipe according to the wear criteria in 10.13.5.

10.4 Pipe body — Full-length electromagnetic inspection (EMI)

10.4.1 Description

Flux-leakage detection equipment uses a strong magnetic field applied to the region of the pipe under the sensors to create a leakage field if properly oriented discontinuities are present. The sensors covered here detect magnetic-flux leakage fields over the pipe external surface at the location of transverse and volumetric imperfections.

10.4.2 Equipment

EMI equipment covered by this part of ISO 10407 includes flux-leakage detection equipment utilizing search coils or Hall-effect sensors. Imperfections are detected by passing the magnetized pipe through a fixed encircling scanner or by propelling the encircling sensors along the length of the magnetized pipe.

The inspection assembly shall be sized according to the size of pipe being inspected.

10.4.3 Surface preparation

The outside diameter of the pipe from upset to upset shall be cleaned to remove scale, mud and coating that can interfere with detector ride and pipe or inspection assembly movement.

10.4.4 Calibration

Electromagnetic inspection units, coils and reference standards shall be calibrated as required in 9.6.

10.4.5 Standardization

10.4.5.1 Reference standards

EMI reference standards are used to establish a common sensitivity for all the detectors; reference inductor dimensions as well as the wall thickness of the reference standard are not specified. Reference standard

surface conditions shall meet the requirements of 10.4.3. The reference standard shall be of the same specified outside diameter as the pipe being inspected. The reference standard may have one or multiple reference indicators. Reference indicators are typically 1,5 mm (1/16 in) through-wall drilled holes. If multiple holes are used, they shall be spaced so that each indication can be seen independent of the others. Multiple-hole reference standards shall be checked according to 9.6.4.

10.4.5.2 Detector sensitivity adjustment

The reference standard shall be inspected at production speed to produce a reference signal from each detector. This requires multiple passes for a single reference indicator standard. The instrumentation should be adjusted to produce an indication having amplitude equal to or greater than 25 % of full scale and clearly identifiable above background noise for each detector. All detectors shall be adjusted to the same signal level ± 10 % of the average amplitude. Full-scale indicators are not allowed since positive variances cannot be determined.

10.4.5.3 Signal-to-noise ratio

Equipment shall provide a minimum signal-to-noise ratio (S/N) of 3 to 1 for reference indicators.

10.4.5.4 Frequency of standardization

General standardization of EMI inspection equipment shall be performed at the beginning of each job.

Periodic standardization checks shall be performed as follows:

- a) at the beginning of each inspection shift;
- b) at least every 50 lengths measured or inspected in a continuous operation;
- c) after any power interruption;
- d) prior to equipment shutdown during a job;
- e) prior to resuming operation after repair or change to a system component that can affect the system performance;
- f) whenever the detector, connector or current setting are changed;
- g) prior to equipment shutdown at the end of the job.

10.4.5.5 Unacceptable checks

Each time the reference standard is inspected, all signals shall be within 20 % of the standardization amplitude. If the periodic check does not meet the above standard, all pipe inspected between an unacceptable check and the most recent acceptable check shall be re-inspected.

10.4.6 Inspection procedures

10.4.6.1 Travelling-head unit on drill pipe

When using travelling-head inspection assemblies, the tool joints on both ends of the pipe shall be bumped with the detectors leading, unless it can be demonstrated that it is not necessary to obtain coverage of the entire pipe body by system-capability demonstration in accordance with 6.5 b). Place the inspection head on the pipe facing the tool joint approximately 0,91 m (3 ft) from the near tool joint, place the coil over the travelling head and inspect the last 0,91 m (3 ft) by propelling the travelling head towards the tool joint until it is stopped by the tool joint. Turn the travelling head around, place the coil back over the travelling head and inspect toward the far tool joint until the travelling head is stopped by the tool joint.

10.4.6.2 Stationary unit

When using a stationary unit, pass each length through the EMI inspection unit.

10.4.6.3 Speed

If the speed varies by more than 10 % from the standardization speed, the area in question shall be re-inspected at the proper speed.

10.4.6.4 Evaluation threshold

A signal amplitude requiring evaluation (threshold) shall be established in accordance with the agency's standard operating procedure and shall not be greater than the reference level. Signals exceeding the threshold shall be located and marked on the outside surface for the full extent of each indication. Evaluate all marked indications in accordance with 10.13.

10.4.6.5 Inspection records

A readout of imperfection indications detected and a record of the inspection shall be made and identified. These documents shall be retained by the agency for a minimum of one year.

NOTE A one-year record retention is sufficient in most situations. If longer retention is required, it is necessary that specific requirements be addressed between the owner/operator and the agency.

10.5 Pipe body — Full-length ultrasonic transverse and wall thickness

10.5.1 General

In 10.5 the equipment requirements and procedures used to perform ultrasonic inspection of the used drill-pipe body between the pipe upsets are described. This inspection is performed to detect transverse imperfections on the inside and outside surface of the pipe. Additionally, the inspection system shall monitor wall thickness for the entire area inspected.

10.5.2 Equipment

The ultrasonic instrument shall be the pulse-echo type with an A-scan presentation. Gain control increments shall be no greater than 0,5 dB. The unit shall have both audible and visual alarms. The units shall be equipped with a strip chart recorder or a digital data-acquisition-and-display system capable of capturing and storing inspection information. The display system shall be capable of displaying information from each transducer orientation individually. The reject control, if available, shall not be used unless it can be demonstrated that it does not affect linearity.

Transducer frequency between 2,25 MHz and 10,0 MHz should be used.

The couplant shall provide an effective acoustic contact between the transducer beams and the pipe surface. The surface shall be free of contaminants that can interfere with the sensitivity of the inspection or the interpretation of the readout. Rust inhibitors, water softeners, glycerine, antifreeze or wetting agents may be added to the couplant provided that they are not detrimental to the pipe surface. A means of monitoring effective acoustic coupling should also be used.

Separate sound beams shall be used for the detection of transverse and wall thickness. The combination of linear and rotational speed of the material and/or scanner shall produce 100 % full-body coverage based upon the effective beam width (EBW) of the transducer and the distance between successive pulses [pulse density (PD)] for each instrument channel. The material may be pre-wet or submerged in part or totally for scanning. The couplant shall provide an effective acoustic contact between the transducer beams and the pipe surface. The EBW and PD shall be defined by the agency.

Shear-wave sound beams are propagated in at least one longitudinal direction to provide for the detection of imperfections oriented transverse to the major axis. The sensitivity of the system shall enable it to detect, display and record transversely oriented and three-dimensional imperfections, such as, but not limited to, cracks and pits.

Compression-wave sound beams propagated normal to the material surface are used to measure wall thickness.

10.5.3 Surface preparation

All drill pipe surfaces to be inspected shall be cleaned as required to remove loose scale, dirt, grease, or any other material that may interfere with the sensitivity of the inspection or the interpretation of the readout.

10.5.4 Calibration

Ultrasonic flaw-detector units shall be calibrated as required in 9.5.2.

The sensors and readout of equipment used to verify coverage (rollers, rotators, etc.) shall be calibrated every six months.

Displays associated with gain (dB) controls shall be calibrated for linearity at least every six months.

10.5.5 Reference standard

The reference standard shall be of a sufficient length for periodic dynamic checks and shall be of the same specified outside diameter, specified wall thickness and acoustical properties as the pipe being inspected.

The reference standard shall contain internal and external transverse surface notches. Reference notches used for standardization shall meet the following requirements:

- maximum length: 12,7 mm (0.5 in);
- maximum depth: 5 % of specified wall thickness;
- maximum width: 1,0 mm (0.040 in).

The effect of the reference notches on signal amplitude shall be verified by comparing the peak amplitudes from both sides of the reflector. The amplitude from one side of the notch shall be at least 79 % (2 dB) of the amplitude from the other side.

New drill pipe shall be manufactured to comply with the requirements of ISO 11961. The 5 % notch specified for used drill pipe in this part of ISO 10407 is established to provide for enhanced detection of fatigue cracks. Standardizing on the 5 % notch can produce indications that are acceptable based on ISO 11961 criteria.

Notches shall be separated such that the indication from each is distinct and separate from the others and from other anomalies or end effects.

The wall-thickness standard may be a separate standard or incorporated into the notched standard. The wall-thickness standard shall contain at least two thicknesses that allow adjustment of the readout over an appropriate range of thickness values for the material being inspected. The reference thicknesses should be verified by measurement with a micrometer or standardized ultrasonic thickness gauge. One thickness shall be equal to or greater than the specified wall thickness of the tube being inspected. The other thickness shall be less than 70 % of the specified thickness. The equipment's readout of wall thickness shall be adjusted to read the reference thicknesses to within 0,25 mm (0.010 in) or 2 % of the specified wall thickness, whichever is the smaller.

10.5.6 Static standardization

The A-scan display range shall be adjusted to at least one-and-a-half skips.

Instrumentation shall be adjusted to produce reference signal amplitudes of at least 60 % of full scale of the readout for each transducer. The signal from each transducer shall respond to within 10 % of the average signal height for all transducers of the same orientation.

A threshold shall be established in accordance with the agency's standard operating procedures and shall not be greater than 60 % of the reference level. The inside and outside surface gates shall be positioned so as to totally encompass the signals received from the inside and outside surfaces, respectively.

Equipment gain and threshold adjustments shall ensure a minimum signal-to-noise ratio (S/N) of 3 to 1.

10.5.7 Dynamic standardization

On rotating systems, the helix shall be sufficient so that all signals are repeatable within two decibels on repeated passes.

A dynamic standardization check shall be performed to ensure repeatability by inspecting the reference standard at production speeds two consecutive times. If the amplitude of the notch for one run is less than 79 % (2 dB) of the amplitude from the other run of the same orientation and notch type, the system shall be adjusted and the dynamic standardization repeated.

10.5.8 Standardization checks

10.5.8.1 Standardization of ultrasonic inspection equipment shall be performed at the beginning of each job.

Additional checks of standardization shall be performed as follows:

- a) at the beginning of each inspection shift;
- b) at least once every 4 h of continuous operation or every 50 lengths inspected, whichever occurs first for mechanized units;
- c) after any power interruption;
- d) prior to equipment shutdown during a job;
- e) prior to resuming operation after repair or change to a system component that can affect system performance;
- f) whenever a transducer or cable is changed or mechanical adjustment to the transducer is made;
- g) prior to equipment shutdown at the end of the job.

10.5.8.2 Unacceptable check conditions

The following conditions constitute an unacceptable check.

- a) A standardization check indicates a change in reference level exceeding 2 dB.
- b) A standardization check shows that any one of the reference points has shifted by more than 5 % of its sweep reading.

All areas inspected between an unacceptable check and the most recent acceptable check shall be re-inspected.

10.5.9 Inspection procedure

Inspect each length, covering the entire inspection area between the upsets, ensuring 100 % coverage. Units with one transverse detector shall scan the last 914 mm (36 in) on each end with the transducer orientation toward the upset and tool joint. The sequence of inspection by the various scanners is not specified, but each one shall perform its respective function effectively and without detrimental interaction with other scanners. As an aid in locating imperfections, additional gain may be used for scanning.

Indications exceeding the reference signal amplitude established in accordance with 10.5.6 shall be located and marked on the outside surface for the full extent of each indication. Evaluate all marked indications in accordance with 10.13.

A readout of imperfection indications detected and a record of the inspection shall be made and identified. These documents should be retained by the agency for a minimum of one year.

NOTE A one-year record retention is sufficient in most situations. If longer retention is required, it is necessary that specific requirements be addressed between the owner/operator and the agency.

10.6 Pipe body — Full-length ultrasonic transverse, wall thickness and longitudinal inspection

10.6.1 General

In 10.6 the equipment requirements and procedures used to perform ultrasonic inspection of the used drill-pipe tube body between the upsets are described. This inspection is performed to detect transverse and longitudinal imperfections on the inside and outside surface of the pipe. Additionally, the inspection system shall monitor wall thickness for the entire area inspected.

10.6.2 Equipment

The ultrasonic instrument shall be the pulse-echo type with an A-scan presentation. Gain-control increments shall be no greater than 0,5 dB. The unit shall have both audible and visual alarms. The units shall be equipped with a strip-chart recorder or a digital data-acquisition-and-display system capable of capturing and storing inspection information. The display system shall be capable of displaying information from each transducer orientation individually. The reject control, if available, shall not be used unless it can be demonstrated that it does not affect linearity.

A transducer frequency between 2,25 MHz and 10,0 MHz should be used.

The couplant shall provide an effective acoustic contact between the transducer beams and the pipe surface. The surface shall be free of contaminants that can interfere with the sensitivity of the inspection or the interpretation of the readout. Rust inhibitors, water softeners, glycerine, antifreeze or wetting agents may be added to the couplant provided they are not detrimental to the pipe surface. A means of monitoring effective acoustic coupling should also be used.

Separate sound beams shall be used for the detection of transverse, longitudinal and wall thickness. The combination of linear and rotational speed of the material and/or scanner shall produce 100 % full-body coverage based upon the EBW of the transducer and the distance between successive pulses for each instrument channel. The material may be pre-wet or submerged in part or totally for scanning. The couplant shall provide an effective acoustic contact between the transducer beams and the pipe surface. The EBW and PD shall be defined by the agency.

10.6.3 Inspections

10.6.3.1 Inspections for longitudinal imperfections

Shear-wave sound beams are propagated clockwise and counter-clockwise by two or more transducers. The sensitivity of the system shall enable it to detect, display and record imperfections oriented parallel to the major axis, such as, but not limited to, seams, laps and cracks.

The angle of the sound beam chosen for inspection shall ensure intersection with the material inside surface.

10.6.3.2 Inspection for transverse imperfections

Shear-wave sound beams are propagated in each longitudinal direction to provide for the detection of imperfections oriented transverse to the major axis. The sensitivity of the system shall enable it to detect, display and record transversely oriented and three-dimensional imperfections, such as, but not limited to, cracks and pits.

10.6.3.3 Inspection for wall thickness

Compression-wave sound beams propagated normal to the materials surface are used to measure wall thickness.

10.6.4 Surface preparation

All drill-pipe surfaces being inspected shall be cleaned as required to remove loose scale, dirt, grease or any other material that can interfere with the sensitivity of the inspection or the interpretation of the readout.

10.6.5 Calibration

Ultrasonic flaw detector units shall be calibrated as required in 9.5.2.

Sensors and readout equipment used to verify coverage (rollers, rotators, etc.) shall be calibrated every six months.

Displays associated with gain (dB) controls shall be calibrated for linearity at least every six months.

10.6.6 Standardization

A reference standard shall be of a sufficient length for periodic dynamic checks and shall be of the same specified outside diameter, specified wall thickness and acoustical properties as the pipe to be inspected.

A reference standard shall contain internal and external transverse and longitudinal notches. Reference notches used for standardization shall meet the following requirements:

- maximum length: 12,7 mm (0.5 in);
- maximum depth: 5 % of specified wall thickness for pipe;
- maximum width: 1,0 mm (0.040 in).

The effect of the reference notches on signal amplitude shall be verified by comparing the peak amplitudes from both sides of the reflector. The amplitude from one side of the notch shall be at least 79 % (2 dB) of the amplitude from the other side.

New drill pipe shall be manufactured to comply with the requirements of ISO 11961. The 5 % notch specified for used drill pipe in this part of ISO 10407 is established to provide for enhanced detection of fatigue cracks. Standardizing on the 5 % notch can produce indications that are acceptable based on ISO 11961 criteria.

Notches shall be separated such that the indication from each is distinct and separate from the others and from other anomalies or end effects.

The wall-thickness standard may be a separate standard or incorporated into the notched standard. The wall-thickness standard shall contain at least two thicknesses that allow adjustment of the readout over an appropriate range of thickness values for the material being inspected. The reference thicknesses should be verified by measurement with a micrometer or standardized ultrasonic thickness gauge. One thickness shall be equal to or greater than the specified wall thickness of the tube being inspected. The other thickness shall be less than 70 % of the specified thickness. The equipment's readout of wall thickness shall be adjusted to read the reference thicknesses within 0,25 mm (0.010 in) or 2 % of the specified wall thickness, whichever is the smaller.

10.6.7 Static standardization

The A-scan display range shall be adjusted to at least one-and-a-half skip.

Instrumentation shall be adjusted to produce reference-signal amplitudes of at least 60 % of the full scale of the readout for each transducer. The signal from each transducer shall respond within 10 % of the average signal height for all detectors of the same orientation.

Equipment gain and threshold adjustments shall ensure a minimum signal-to-noise ratio (S/N) of 3 to 1.

10.6.8 Dynamic standardization

10.6.8.1 General

On rotating systems, the helix shall be sufficient so that all signals are repeatable within 2 dB on repeated passes.

A dynamic standardization check shall be performed to ensure repeatability by inspecting the reference standard at production speeds two consecutive times. If the amplitude of the notch for one run is less than 79 % (2 dB) of the amplitude from the other run of the same orientation and notch type, the system shall be adjusted and the dynamic standardization repeated.

10.6.8.2 Ultrasonic inspection equipment

Standardization of ultrasonic inspection equipment shall be performed at the beginning of each job.

Additional checks of standardization shall be performed as follows:

- a) at the beginning of each inspection shift;
- b) at least once every 4 h of continuous operation or every 50 lengths inspected, whichever occurs first for mechanized units;
- c) after any power interruption;
- d) prior to equipment shutdown during a job;
- e) prior to resuming operation after repair or change to a system component that can affect system performance;
- f) whenever a transducer or cable is changed or mechanical adjustment to the transducer is made;
- g) prior to equipment shutdown at the end of the job.

10.6.8.3 Unacceptable check conditions

The following conditions constitute an unacceptable check.

- a) A standardization check indicates a reduction in signal amplitude from the reference flaw exceeding 2 dB.
- b) A standardization check shows that any reference point has shifted by more than 5 % of its sweep reading.

All areas inspected between an unacceptable check and the most recent acceptable check shall be re-inspected.

10.6.9 Inspection procedure

Inspect each length, covering the entire inspection area between the upsets, ensuring at least 100 % coverage. The sequence of inspection by the various scanners is not specified, but each one shall perform its respective function effectively and without detrimental interaction with other scanners. As an aid in locating imperfections, additional gain may be used for scanning.

Indications exceeding the reference signal amplitude established in 10.7 shall be located and marked on the outside surface for the full extent of each indication. Evaluate all marked indications in accordance with 10.13.

As an aid in locating imperfections, additional gain may be used for scanning.

A readout of imperfection indications detected and a record of the inspection shall be made and identified. These documents should be retained by the agency for a minimum of one year.

NOTE The one-year record retention is sufficient in most situations. If longer retention is required, it is necessary that specific requirements be addressed between the owner/operator and the agency.

10.7 Drill-pipe body — External magnetic-particle inspection of the critical area

10.7.1 General

In 10.7 equipment requirements, descriptions and procedures for dry magnetic-particle inspection of the external surface of the critical area on used drill-pipe tubes are provided. Wet fluorescent magnetic-particle or white background and black wet-particle techniques may be substituted for dry magnetic particles. This inspection is performed primarily to detect transverse cracks on the outside diameter surface of the pipe. This inspection is also applied to HWDP. These inspection procedures may be applied to BHA drill stem elements to cover specific areas as well as full-length inspection.

For the purposes of this part of ISO 10407, the critical area extends from the base of the tapered shoulder of the tool joint to a plane located at a distance of 660 mm (26.0 in) or to the end of the slip marks, whichever is greater (see Figure 4). On HWDP, the area 457 mm (18.0 in) on either side of the centre wear pad is also inspected.

10.7.2 Equipment

10.7.2.1 Longitudinal field

An AC yoke or a coil, either AC or DC (HWAC, FWAC or filtered FWAC or pulsating DC), may be used for this inspection. The number of turns of the coil shall be clearly marked on the coil.

10.7.2.2 Dry magnetic particles

Dry magnetic particles shall meet the requirements of 9.4.8.2. A powder bulb capable of applying magnetic particles in a light dusting shall be used.

10.7.2.3 Wet magnetic particles

10.7.2.3.1 Fluorescent-particle inspection

Fluorescent magnetic-particle solutions complying with the requirements of 9.4.8.3 may be used as an alternative method. An ultraviolet light source, fluorescent magnetic particles, a 100 ml centrifuge tube (graduated in 0,05 ml increments) and an ultraviolet light meter are required. If the particles are supplied as an aerosol, the centrifuge tube is not required.

10.7.2.3.2 White background and black magnetic particles

White background and black magnetic-particle wet-inspection aerosol materials shall be from the same manufacture, or specified as compatible by the product manufacturer and used in accordance with the manufacturer's requirements.

10.7.3 Illumination

Illumination of the inspection surfaces for visual inspection and visible-light magnetic-particle inspection shall comply with the requirements of 9.3.2.

Illumination of the surfaces for fluorescent magnetic-particle inspection shall comply with the requirements of 9.4.8.5.

10.7.4 Surface preparation

The inspection areas shall be cleaned of all grease, thread compound, dirt and any other foreign matter that can interfere with particle mobility and indication detection. When using dry magnetic-particle techniques, all surfaces being inspected shall be powder dry.

Surface coatings (paint, etc.), including white background coating if a white background and black magnetic particle system is used, shall be smooth and shall have a thickness $\leq 0,05$ mm (0.002 in).

10.7.5 Calibration

Equipment calibration is covered in Clause 9.

10.7.6 Standardization

10.7.6.1 DC coil

Select a typical pipe from the string for inspection. Place the coil on the pipe with the centreline approximately 305 mm (12.0 in) from the tapered shoulder. Energize the coil to establish a residual longitudinal field. Using the residual field, apply magnetic particles to the area 305 mm (12.0 in) on either side of the coil. Observe any magnetic-particle build-up (furring) near the end of the 305 mm (12.0 in) inspection area on either side of the coil. If there is no magnetic-particle build-up, increase the magnetic field strength and reapply magnetic particles. If there is a magnetic-particle build-up, reverse the coil and apply slightly less current. Continue until only light magnetic-particle build-up is present in inspection area. Note the amperage required to establish the magnetic field; that amperage becomes the magnetizing level for use during inspection.

For wet particles, observe the magnetic-particle mobility near the end of the 305 mm (12.0 in) on either side of the coil. If the magnetic particles continue to flow for longer than 10 s, increase the magnetic field strength and reapply magnetic particles. If the magnetic particles are pulled out of suspension prematurely, i.e. during less than 6 s, reverse the coil and apply slightly less current. Continue until the magnetic particle mobility is from 6 s to 10 s after application. Note the amperage required to establish the magnetic field; that amperage becomes the magnetizing level for use during inspection.

NOTE Excessive ampere-turns (NI) can produce furring of dry magnetic particles on the outside surface that can conceal indications. Excessive ampere-turns (NI) can cause lack of mobility of wet particles that results in increased background noise and can reduce the indication brightness.

10.7.6.2 AC coil

Select a typical pipe from the string for inspection. Place the coil on the pipe with the centreline approximately 305 mm (12.0 in) from the tapered shoulder. Energize the coil and apply magnetic particles to both sides of the coil and observe the distance over which the particles have definitive movement due to the magnetic field [normally 76 mm (3 in) to 102 mm (4 in)]. This distance becomes the inspection distance for each placement of the AC coil.

10.7.7 Inspection procedures

10.7.7.1 Steps for inspection

The steps for inspection found in 10.7.7 are the minimum requirements and can vary depending upon the drill-pipe condition and the options agreed to between the owner and the agency.

The steps for inspection are as follows.

- a) Inspect the entire critical area for visually detectable imperfections.
- b) Place the coil over the first area to be inspected.
- c) For the DC coil, the maximum coverage area for each coil placement is 305 mm (12.0 in) on either side of the coil centreline.
- d) For the AC coil, the distance established in 10.7.6.2 above is the maximum inspection distance.
- e) Multiple placements are required to inspect the entire area.

10.7.7.2 DC coils

For DC coils, energize the coil with the magnetizing current level established during standardization for at least 1 s.

The steps for inspection are as follows.

- a) Turn the coil off.
- b) Move the coil out of the way and conduct a magnetic-particle inspection, covering the inspection area [maximum 305 mm (12.0 in) on either side of the coil centreline] completely around the pipe, paying particular attention to the root of any cuts, gouges, corrosion pits and/or slip cuts.
- c) Repeat the process with at least a 51 mm (2 in) overlap until the entire area being inspected has been covered.
- d) Remove magnetic particles after inspection.

10.7.7.3 AC coils

For AC coils, place the coil over the area being inspected and energize the coil.

The steps for inspection are as follows.

- a) With the current on, conduct the inspection of the pipe in the coverage area completely around the pipe, paying particular attention to the tube area adjacent to the upset, the root of any cuts, gouges, corrosion pits and/or slip cuts.

- b) Repeat the process with at least a 25 mm (1.0 in) overlap until the entire area being inspected has been covered.
- c) Remove magnetic particles after inspection.

10.7.8 Evaluation

Evaluate all imperfections in accordance with 10.13.

10.8 Drill-pipe body — Bi-directional external magnetic-particle inspection of the critical area

10.8.1 General

In 10.8 equipment requirements, descriptions and procedures for magnetic-particle inspection of the external surface of the critical area on used drill-pipe tubes are provided. The wet fluorescent magnetic-particle or white background and black magnetic-particle wet method shall be used. This inspection is performed to detect transverse and longitudinal cracks on the outside diameter surface of the pipe. This inspection is also applied to HWDP. These inspection procedures may be applied to BHA drill stem elements to cover specific areas as well as full-length inspection.

For the purposes of this part of ISO 10407, the critical area is from the base of the tapered shoulder of the tool joint to a plane located at a distance of 660 mm (26.0 in) or to the end of the slip marks, whichever is greater (see Figure 4). On HWDP, the area 457 mm (18.0 in) on either side of the centre wear pad is inspected.

10.8.2 Equipment

10.8.2.1 Longitudinal field

An AC yoke or a coil, either AC or DC (HWAC, FWAC or filtered FWAC or pulsating DC), may be used for this inspection. The number of turns of the coil shall be clearly marked on the coil.

10.8.2.2 Transverse/circular field

An AC yoke or internal conductor may be used. The current for the internal conductor may be supplied with DC, a three-phase rectified AC power supply or capacitor-discharge power supply. The power supply shall be capable of meeting the amperage requirements of Table C.2 (Table D.2). Table C.4 (Table D.4) provides the nominal linear mass [mass per metre (foot)] for various pipe sizes.

10.8.2.3 Wet magnetic particles

10.8.2.3.1 Fluorescent-particle inspection

Fluorescent magnetic-particle solutions shall comply with the requirements of 9.4.8.3. An ultraviolet light source, fluorescent magnetic particles, a 100 ml centrifuge tube (graduated in 0,05 ml increments) and an ultraviolet light meter are required. If the particles are supplied as an aerosol, the centrifuge tube is not required.

10.8.2.3.2 White background and black magnetic particles

White background and black magnetic-particle wet-inspection aerosol materials shall be from the same manufacturer, or specified as compatible by the product manufacturer and used in accordance with the manufacturer's requirements.

10.8.3 Illumination

Illumination of the inspection surfaces for visual inspection and visible-light black magnetic-particle inspection shall comply with the requirements of 9.3.2.

Illumination of the surfaces for fluorescent magnetic-particle inspection shall comply with the requirements of 9.4.8.5.

10.8.4 Surface preparation

The inspection areas shall be cleaned of all grease, thread compound, dirt and any other foreign matter that can interfere with particle mobility, complete wetting of the surface by the particle carrier and indication detection.

Surface coatings (paint, etc.) including the white background coating if white background and black magnetic-particle system is used, shall be smooth and shall have a thickness $\leq 0,05$ mm (0.002 in).

10.8.5 Calibration

Equipment calibration is in accordance with in Clause 9.

10.8.6 Standardization

10.8.6.1 DC coil

Select a typical pipe from the string for inspection. Place the coil on the pipe with the centreline approximately 305 mm (12.0 in) from the tapered shoulder. Energize the coil to establish a residual longitudinal field. Using the residual field, apply magnetic particles to the area 305 mm (12,0 in) on either side of the coil. Observe the magnetic-particle mobility near the end of the 305 mm (12,0 in) on either side of the coil. If the magnetic particles continue to flow for longer than 10 s, increase the magnetic field strength and reapply magnetic particles. If the magnetic particles are pulled out of suspension prematurely, i.e. within an interval shorter than 6 s, reverse the coil and apply slightly less current. Continue until the magnetic-particle mobility is from 6 s to 10 s after application. Record the amperage required to establish the magnetic field; that amperage becomes the magnetizing level for use during inspection.

NOTE Excessive ampere-turns (NI) can cause lack of mobility of the wet particles that results in increased background noise and can reduce indication brightness.

10.8.6.2 AC coil

Select a typical pipe from the string for inspection. Place the coil on the pipe with the centreline approximately 305 mm (12,0 in) from the tapered shoulder. Energize the coil and apply magnetic particles to both sides of the coil and observe the distance over which the particles have definitive movement due to the magnetic field [normally 76 mm (3 in) to 102 mm (4 in)]. This distance becomes the inspection distance for each placement of the AC coil.

10.8.6.3 AC yoke

Select a typical pipe from the string for inspection and adjust the legs of the yoke to maximize contact with the pipe surface when positioned for the appropriate inspection direction.

10.8.6.4 Magnetizing rod

The magnetizing rod shall be completely insulated from the pipe. The power-supply requirements in Table C.2 (Table D.2) shall be met. The current level specified in the table shall be the magnetizing current for the longitudinal inspection.

10.8.7 Inspection procedures

10.8.7.1 Visual inspection

Inspect the entire critical area for visually detectable imperfections.

10.8.7.2 Fluorescent method

10.8.7.2.1 General

The inspection area shall be inspected with both a longitudinal and transverse/circular magnetic field using one of the procedures in 10.8.7.2.2 to 10.8.7.2.4 for each. The following steps are conducted in a darkened area (21,5 lx maximum visible light). The inspector shall be in the darkened area at least 1 min prior to beginning inspection to allow the eyes to adapt. Darkened lenses or photochromic lenses shall not be worn.

10.8.7.2.2 Yoke

With the critical area in a darkened location, place the yoke transversely across the pipe OD approximately 12,7 mm (0.5 in) from the tapered shoulder. Energize the yoke and, while the current is on, apply the magnetic-particle bath by gently spraying or flowing the suspension over the pipe OD in the magnetized area. Allow at least 3 s for indications to form and then examine the area using ultraviolet light, while still applying the current.

If no indication is found, turn off the yoke and move it, allowing for proper overlap, and repeat the above procedure. Continue to inspect and move until the entire OD surface of the critical area has been inspected for longitudinal indications.

Inspect the entire area with the legs of the yoke placed longitudinally following the same procedures above. Apply the particle bath by gently spraying or flowing the suspension over the pipe OD in the magnetized area. Allow at least 3 s for indications to form and then examine the area using ultraviolet light. Continue to inspect and move until the entire OD surface of the critical area has been inspected for transverse indications.

10.8.7.2.3 Coil

With the critical area in a darkened location, place the coil over the pipe OD approximately 305 mm (12 in) from the tool-joint tapered shoulder. Magnetize the critical area as established during standardization and apply the particle bath by gently spraying or flowing the suspension over the pipe. Allow at least 3 s for indications to form and then examine the area using ultraviolet light.

Roll the pipe for complete circumferential inspection, then move the coil along the pipe to inspect successive areas until 100 % of the critical area OD surface has been inspected for transverse indication with a minimum of 25 mm (1.0 in) overlap of the coverage areas between coil placements.

10.8.7.2.4 Magnetizing rod

Magnetize the pipe. With the tool joint in a darkened area, apply the particle bath by gently spraying or flowing the suspension over the entire length of the critical area. Allow at least 3 s for indications to form and then examine the area for longitudinal indications using ultraviolet light.

Roll the tool joint and inspect successive areas until 100 % of the critical area OD surface has been inspected.

10.8.7.3 White background and black magnetic-particle wet method

10.8.7.3.1 General

The inspection area shall be inspected with both a longitudinal and a transverse/circular magnetic field using one of the procedures in 10.8.7.3.2 to 10.8.7.3.4 for each. The following steps are conducted in a lighted area

(538 lx minimum visible light). Darkened lenses or photochromic lenses shall not be worn. White contrast background materials shall be applied to the entire pipe outside diameter critical area in a light, even coat. Care shall be taken not to damage the background coating during handling until the inspection is complete.

10.8.7.3.2 Yoke

With the pipe in a lighted area, place the yoke transversely across the pipe OD approximately 12,7 mm (0.5 in) from the tapered shoulder. Energize the yoke and, while the current is on, apply the particle bath by gently spraying or flowing the suspension over the pipe OD in the magnetized area. Allow at least 3 s for indications to form and then examine the area for longitudinal imperfections while still applying the current.

If no indication is found, turn off the yoke and move it, allowing for proper overlap, and repeat the above procedure. Continue to inspect and move until the entire critical area OD surface has been inspected for longitudinal imperfections.

Inspect the entire critical area for transverse indication with the legs of the yoke placed longitudinally following the same procedures as above.

10.8.7.3.3 Coil

With the critical area in an adequately lit location, place the coil over the pipe OD approximately 305 mm (12 in) from the tool-joint tapered shoulder. Magnetize the critical area as established during standardization and apply the particle bath by gently spraying or flowing the suspension over the pipe critical area OD surface. Allow at least 3 s for indications to form and then examine the area for transverse indications.

Roll the tool joint and inspect successive areas until 100 % of the critical area OD surface has been inspected.

10.8.7.3.4 Magnetizing rod

Magnetize the pipe. With the pipe in an adequately lit area, apply the particle bath by gently spraying or flowing the suspension over the entire critical area. Allow at least 3 s for indications to form and then examine the area for longitudinal imperfections.

Roll the pipe and inspect successive areas until 100 % of the critical area OD surface has been inspected.

10.8.7.3.5 Post-inspection

Do not leave magnetic particles or cleaning materials on the pipe after inspection. If using black and white, follow the customer's requirement regarding removal of white background materials.

10.8.8 Evaluation

Evaluate all imperfections in accordance with 10.13.

10.9 Pipe body — Full-length wall-loss inspection

10.9.1 General

In 10.9 the procedures used for full-length pipe-wall-loss inspection are described, using either of two techniques: gamma-ray equipment or Hall-effect magnetic-field sensors. The technique described in 10.9 does not measure wall thickness but rather changes in wall thickness. Both gamma-ray equipment and Hall-effect magnetic-field sensors help identify areas that require evaluation. When available, this equipment is typically an integral component of an EMI inspection system and therefore not available as a separate, stand-alone inspection.

10.9.2 Application

Classification criteria are based on the minimum remaining wall thickness at any location. Full-length wall-loss inspection can be necessary to document compliance with this requirement.

10.9.3 Equipment and materials

10.9.3.1 Gamma-ray equipment

The equipment typically consists of a gamma-ray source, a sensor and readout. Monitoring is normally made on a helical path along the length. Surface coverage is typically not 100 %. Pipe speed and rotation of the source along with the radiation-beam size determines the coverage area.

10.9.3.2 Hall-effect equipment

The equipment typically consists of a number of Hall-effect sensors positioned between the inside of the magnetizing coil and the outside surface of the pipe. Surface coverage might not be 100 % and is dependent on sensor quantity, orientation and position. Hall sensors monitor changes in the magnetic flux density in the area caused by large-area wall loss and/or the magnetic-flux leakage perturbation caused by localized discontinuities within the pipe-body wall.

Large areas of wall-thickness variation, such as OD wear, cause changes in the magnetic flux density. The flux-density changes tend to be distributed evenly around the entire pipe circumference even though the wall loss can be only on one side. It might not be possible to determine a specific sector of the pipe that contains the wall-loss defect.

Areas of localized wall-loss, such as pitting or erosion, can create areas of localized flux leakage. These localized magnetic-flux leakage perturbations can be used to locate the specific sector around the pipe circumference.

10.9.3.3 Reference standards

For gamma-ray units, a steel reference standard with two known thicknesses shall be used. It shall be of the same specified outside diameter and wall thickness as the pipe being inspected.

For Hall-element units, a steel reference standard of the same outside diameter shall be used. The reference standard shall have a wall reduction, typically 5 % of the reference standard wall thickness, with a smooth, sloping taper between the wall reduction and the nominal OD, simulating OD wear.

10.9.4 Calibration

For gamma-ray systems, instrument readouts for determining rotational speed and linear speed or inspection-mechanism speed (if used to monitor coverage) shall be calibrated as required by 9.6.3.

10.9.5 Standardization

10.9.5.1 Gamma ray

The standardization of the gamma-ray system shall be accomplished using one or more of the following methods.

- a) The gain of the system is adjusted so that the readout corresponds with the two known thicknesses of a reference standard.
- b) The gain of the system is adjusted so that the readout corresponds with the measured thickness values on a selected circumferential ring of a reference standard having the same specified diameter and specified wall thickness as the pipe being inspected.

- c) On the ring, a minimum and maximum thickness shall be determined using a micrometer or properly standardized ultrasonic thickness gauge. The readout of the wall-thickness measuring system should be standardized to a specific scale. The readout's minimum thickness value should be adjusted to be within $\pm 0,25$ mm (± 0.010 in) of the minimum thickness selected on the reference standard. The maximum thickness of the standard should be clearly distinguishable on the readout.

10.9.5.2 Hall effect

Hall-effect wall-loss monitoring is used only to identify areas of wall reduction for subsequent evaluation by ultrasonic thickness measurement. Standardization is not quantitative. A reference standard with an area of reduced wall simulating OD wear shall be used to verify the ability of the unit to detect wall reductions. The reduced wall section of the standard shall be passed under each wall sensor. Each time the wall-loss reference standard is inspected, all signals shall be within 20 % of the standardization amplitude.

10.9.5.3 Frequency of standardization

General standardization shall be performed at the beginning of each job.

Periodic standardization checks shall be performed as follows:

- a) at the beginning of each inspection shift;
- b) at least every 50 lengths measured or inspected in a continuous operation;
- c) after any power interruption;
- d) prior to equipment shutdown during a job;
- e) prior to resuming operation after repair or change to a system component that can affect system performance;
- f) whenever the detector, connector or current setting is changed;
- g) prior to equipment shutdown at the end of the job.

10.9.5.4 Unacceptable checks

Each time the reference standard is inspected, all signals shall be within 20 % of the initial standardization amplitude. If the periodic check does not meet the above standard, all pipe inspected between an unacceptable check and the most recent acceptable check shall be re-inspected.

10.9.6 Inspection procedure

Each length of pipe shall be inspected as described in 10.4. A threshold for indications requiring evaluation shall be established in accordance with the agency's standard operating procedure.

For Hall-element systems, the wall thickness reading to satisfy the requirements of 10.3 should be made for all areas that produce a significant wall indication.

10.9.7 Evaluation

Areas of suspected wall reduction shall be marked with non-permanent paint on the pipe surface. Evaluate all marked indications in accordance with 10.13.

10.10 Pipe body — Ultrasonic inspection of the critical area

10.10.1 General

In 10.10 the equipment requirements and procedures used to perform ultrasonic inspection of the critical area on used drill-pipe body are described. This inspection is performed primarily to detect transverse cracks on the inside and outside surface of the pipe. The set-up for this inspection is based on specified pipe-wall thickness and, therefore, is not intended to include the transition or the weld area. This inspection is also applied to HWDP.

The critical area is from the base of the tapered shoulder of the tool joint to a plane located at a distance of 660 mm (26.0 in) or to the end of the slip marks, whichever is greater (see Figure 4). On HWDP, the area 457 mm (18.0 in) on either side of the centre wear pad is inspected.

10.10.2 Equipment

The ultrasonic instrument shall be of the pulse-echo type with an A-scan presentation. Gain-control increments shall be no greater than 0,5 dB. The unit shall have both audible and visual alarms. For inspections performed with equipment other than a hand-held, single-element transducer, a means of permanently recording standardizations and relevant indications shall be part of the inspection system. The reject control shall not be used.

A transducer frequency between 2,25 MHz and 10,0 MHz should be used.

Wedges or other transducer-angling method shall be used to generate shear waves in the material being inspected.

NOTE The use of a 45° refracted angle is typical.

A liquid couplant shall be used to wet the surface of the pipe and provide transmission of ultrasound from the transducers into the pipe being tested. The surface shall be free of contaminants that can interfere with the sensitivity of the inspection or the interpretation of the readout. Rust inhibitors, water softeners, glycerine, antifreeze or wetting agents may be added to the couplant provided they are not detrimental to the pipe surface and environment.

10.10.3 Surface preparation

All drill-pipe surfaces being inspected shall be cleaned, as required, to remove loose scale, dirt, grease or any other material that can interfere with the sensitivity of the inspection or the interpretation of the readout.

10.10.4 Calibration

The ultrasonic flaw detector shall be calibrated as required in 9.5.2.

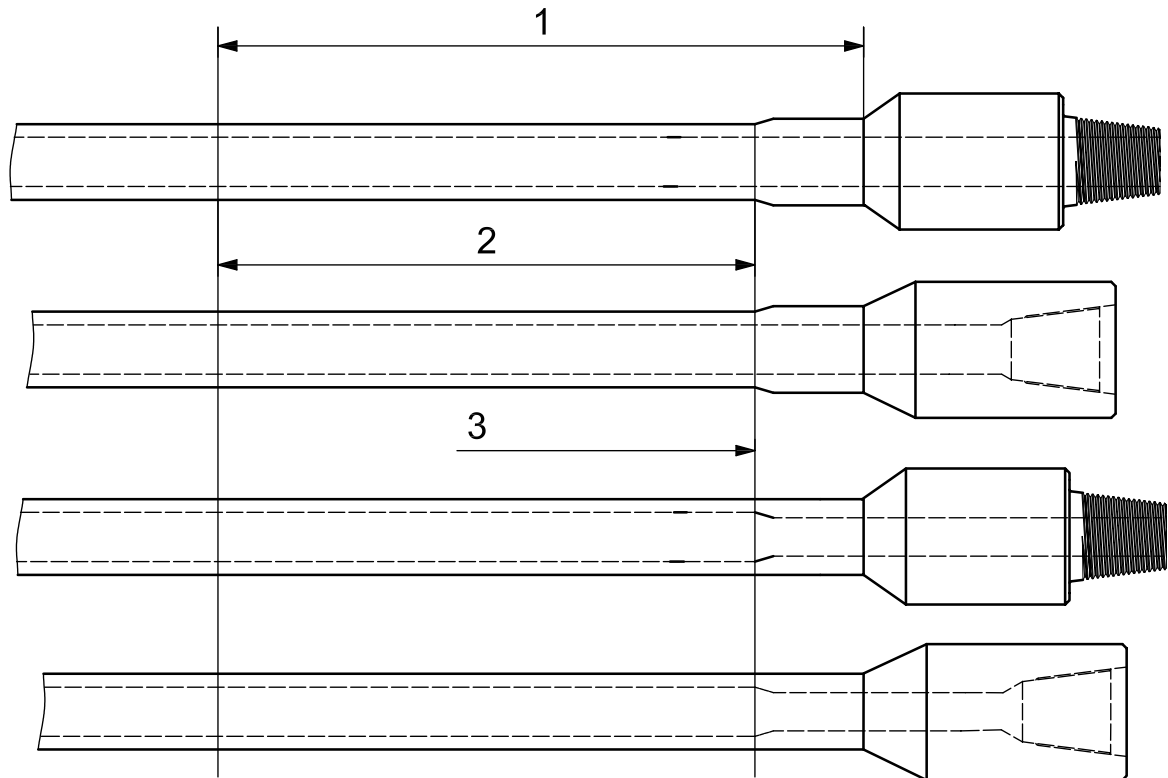

Key

- 1 length of critical area, equal to 650 mm (26 in) from tapered shoulder or to end of slip marks, whichever is greater
- 2 ultrasonic inspection effective length
- 3 upset run out

Figure 4 — Ultrasonic end-area inspection — Effective length

10.10.5 Standardization

A reference standard should be of a length sufficient for periodic dynamic checks and shall be of the same specified outside diameter, specified wall thickness and acoustical properties as the pipe being inspected.

A reference standard shall contain internal and external transverse surface notches. The reference notches used for standardization shall meet the following requirements:

- maximum length: 12,7 mm (0.5 in);
- maximum depth: 5 % of specified wall thickness;
- maximum width: 1,0 mm (0.040 in).

The effect of the reference notches on signal amplitude shall be verified by comparing the peak amplitudes from both sides of the reflector. The amplitude from one side of the notch shall be at least 79 % (2 dB) of the amplitude from the other side.

New drill pipe shall be manufactured to comply with the requirements of ISO 11961. The 5 % notch specified for used drill pipe in this part of ISO 10407 is established to provide for enhanced detection of fatigue cracks. Standardizing on the 5 % notch can produce indications that are acceptable based on ISO 11961 criteria.

Notches shall be separated such that the indication from each is distinct and separate from the others and from other anomalies or end effects.

10.10.6 Static standardization

The A-scan display range shall be adjusted to at least one-and-a-half skips.

The instrumentation shall be adjusted to produce reference-signal amplitudes of at least 60 % of full scale of the readout for each transducer. If multiple transducers are used, all the responses shall be within 10 % of the average signal height.

A threshold shall be established in accordance with the agency's standard operating procedures and shall not be greater than the reference level. Inside and outside surface gates shall be positioned so as to totally encompass the signals received from the inside and outside surfaces, respectively.

Equipment gain and threshold adjustments shall be set for a minimum signal-to-noise ratio (S/N) of 3 to 1.

10.10.7 Dynamic standardization

A dynamic standardization check shall be performed to ensure repeatability by inspecting the reference standard at production speeds two consecutive times. If the amplitude of the notch for one run is less than 79 % (2 dB) of the amplitude from the other run, the system shall be adjusted and the dynamic standardization repeated. A permanent record of each standardization shall be made and identified, excluding hand-held single-element-type equipment.

10.10.8 Standardization checks

10.10.8.1 General

Standardization of ultrasonic inspection equipment shall be performed at the beginning of each job.

Additional checks of standardization shall be performed as outlined below:

- a) at the beginning of each inspection shift;
- b) at least once every 2 h of continuous operation or every 50 ends inspected, whichever occurs first for mechanized units or, for manual methods, at least every 25 areas inspected in a continuous operation;
- c) after any power interruption or change in power supply (battery to charger);
- d) for manual methods, whenever there is a change of operator (inspector);
- e) prior to equipment shutdown during a job;
- f) prior to resuming operation after repair or change to a system component that can affect system performance;
- g) whenever the transducer, cable, wedge or type of couplant is changed;
- h) prior to equipment shutdown at the end of the job.

10.10.8.2 Unacceptable check conditions

The following conditions constitute an unacceptable check.

- a) A standardization check indicates the amplitude of the notch is less than 79 % (2 dB) of the reference level.
- b) A standardization check shows that any reference point has shifted by more than 5 % of its sweep reading.

All areas inspected between an unacceptable check and the most recent acceptable check shall be re-inspected.

10.10.9 Inspection procedure

The scanning assembly shall be placed so that each scanning pass covers the entire inspection distance. Sound-beam direction and scanning direction shall be towards the upsets. Scanning shall continue until the upset or tool-joint tapered shoulder breaks coupling. Each scanner (transducer), if more than one, shall perform its respective function effectively and without detrimental interaction with other scanners.

Inspect the required coverage area at each end of the pipe body (as specified in 10.10.1), with the ultrasonic inspection system, ensuring 100 % coverage.

On rotating systems, the helix shall be sufficient that all signals are repeatable within 2 dB on repeated passes.

On wedge systems, the overlap of successive passes shall be such that at least the centre beam of the outside transducers are coincident.

To aid in locating imperfections, scanning may be performed with additional gain.

10.10.10 Evaluation

Cracks have no acceptable tolerance, any discernable crack-like indication shall be evaluated.

Indications exceeding the threshold established in 10.10.6 shall be located and marked on the outside surface for the full extent of each indication. Evaluate all marked indications in accordance with 10.13.

On units so equipped, a strip-chart readout of imperfection indications detected shall be made and identified. These documents shall be retained by the agency for a minimum of one year.

A permanent record of all imperfection indications detected shall be made and identified, excluding hand-held single-element-type equipment. These documents shall be retained by the agency for a minimum of one year.

10.11 Pipe body — Calculation of cross-sectional area

10.11.1 Description

The actual minimum cross-sectional area of the tube in a string can be of benefit where a requirement for high hook loads occurs. This inspection calculates the cross-sectional area at the point that ultrasonic readings are taken in accordance with 10.3 or may be accomplished by use of a direct-indication instrument that the operator can demonstrate has a 2 % accuracy by use of a pipe section approximately the same as the pipe being inspected.

NOTE Unless full-length monitoring is done in accordance with 10.5, 10.6 or 10.9, there is no assurance that the area where the cross-sectional area is calculated is the actual location of the minimum cross-sectional area of the pipe.

10.11.2 Inspection procedures

The requirements of 10.3 apply when wall thickness is determined by use of an ultrasonic thickness device. When a direct-reading instrument is used, requirements are established by agreement between the contracting agency and inspection company.

When ultrasonic wall-thickness measurements are used, integrated wall-thickness measurements taken at 25 mm (1.0 in) intervals around the tube shall be used to determine the average wall thickness for that section of the tube. The wall-thickness values shall be added and averaged, with the average becoming the average wall thickness.

The average diameter shall be obtained directly by use of a “pi” (π) tape around the circumference.

Using the average wall thickness and average diameter, calculate the cross-sectional area, A_{CS} , from Equation (1):

$$A_{CS} = (D - t) \times t \times \pi \quad (1)$$

where

D is the average diameter as determined with the “pi” tape;

t is the average wall thickness as determined with average ultrasonic reading;

π is a constant equal to 3,1416.

10.11.3 Evaluation and classification

This inspection is informational; this cross-sectional area is not used to classify the pipe.

10.12 Pipe body — Document review (traceability)

The component shall be traceable through heat and heat-treatment lot identification. Identification shall be maintained for all usable materials. Identification shall be maintained for all drill stem elements through all stages of manufacturing and on finished drill stem elements or assemblies. Manufacturers’ documented traceability requirements shall include provisions for maintenance and replacement of identification marks and identification-control records. BHA drill stem elements should meet the material requirements for drill collars.

A full document review should include

- item original serial number,
- item replacement serial number(s),
- heat and heat-treatment lot numbers,
- material requirements, and
- certified material test reports.

Full documentation might not be available for all equipment. Specifying full documentation limits available drill stem elements to those manufactured to these requirements and with traceability maintained through the life of the component.

10.13 Pipe body — Evaluation and classification

10.13.1 General

In 10.13 the procedures for the evaluation and classification of imperfections and deviations detected using the methods contained in this part of ISO 10407 are described. While the classification criteria are the same for several types of imperfections, such as outside diameter wear and remaining wall at the base of a pit, the separate categories are maintained because of the differences in the evaluation process and the information provided to the interested parties concerning the reasons for any downgrades.

10.13.2 Application

The evaluation procedures contained in 10.13 are applicable to all drill pipe except those classified as premium as the result of inspection.

10.13.3 Equipment

Equipment used in conjunction with evaluation procedures includes, but is not limited to, the following:

- a) depth gauges;
- b) straight edges;
- c) rules, rigid and flexible;
- d) portable ultrasonic inspection equipment;
- e) magnetic-particle inspection equipment;
- f) outside diameter calliper.

10.13.4 Calibration and standardization procedures

All equipment and materials used to evaluate imperfections shall be calibrated on a regular basis in accordance with the provisions of the agency's quality assurance programme.

In addition, the following standardizations shall be performed:

- a) ultrasonic thickness measurement (see 10.3 for the standardization procedure);
- b) shear-wave ultrasonic equipment (see 10.10 for the standardization procedure);
- c) MT equipment and materials (see Clause 9 for the standardization procedure).

10.13.5 Procedure for evaluation of drill-pipe OD wear

When OD wear is detected using an ultrasonic thickness gauge standardized in accordance with 10.3, search around the circumference at the point of maximum OD wear for the minimum wall thickness.

Search the surrounding area for the minimum wall thickness to determine whether the wall is further reduced along the pipe axis in either direction or on a diagonal.

Once satisfied that the minimum wall thickness has been located, that value becomes the remaining wall thickness used to classify the pipe according to the criteria for OD wear in Tables B.18 and B.19.

Values for classification of the tube based on the remaining wall thickness due to outside diameter wear as shown in Table C.4 (Table D.4) for drill pipe and Table C.5 (Table D.5) for work-string tubing are based on the following:

- a) For premium class, the remaining wall shall not be less than 80 % of the new specified wall.
- b) For class 2, the remaining wall shall not be less than 70 % of the new specified wall.
- c) For class 3, the wall thickness is less than the minimum for class 2.

10.13.6 Procedure for the evaluation of drill-pipe stress-induced diameter reduction

A reduction in outside diameter without a corresponding reduction of wall thickness is indicative of stress-induced diameter reduction. This procedure is used when the detected localized diameter decrease is due to dents and mashes, crushing and necking or stretching.

NOTE 1 Stretching pipe causes a percent reduction in the wall thickness of approximately half of the percentage reduction in outside diameter. Thus, on a drill pipe Label 1, 5, and Label 2, 19,50, wall thickness 9,19 mm (0.362 in) wall

drill pipe, a 5 % reduction in the outside diameter due to stretching would cause a 2,5 % wall-thickness reduction, or about 0,23 mm (0.009 in), rather than the 3,18 mm (0.125 in) that is expected from a 5 % wear reduction in the outside diameter.

NOTE 2 A neck in the pipe due to stretching indicates that the pipe has experienced tension loads as high as the actual yield strength of the drill pipe.

Using the OD callipers, search the area of outside-diameter reduction for the minimum outside diameter.

Set the callipers to the diameter of the pipe at the point of minimum outside diameter and, using a metal rule, determine the diameter at that point.

Record the reduced diameter on the worksheet. This value becomes the diameter used to classify the pipe according to the criteria for stress-induced diameter reduction.

Classify the pipe based on the requirements of Table B.18 for drill pipe and Table B.19 for the appropriate pipe size and wall thickness. Record the classification. Values for classification based on remaining outside diameter are given in Table C.4 (Table D.4) for drill pipe and Table C.5 (Table D.5) for work-string tubing.

10.13.7 Procedure for the evaluation of drill-pipe stress-induced diameter increase

This procedure is used when localized diameter increase is detected due to string shot.

Using the OD callipers, search the area of outside diameter increase for the maximum outside diameter.

Set the callipers to the diameter of the pipe at the point of maximum outside diameter and, using a metal rule, determine the diameter at that point.

Record the diameter on the worksheet. This value becomes the diameter used to classify the pipe according to the criteria for stress-induced diameter increase.

Classify the pipe based on the requirements of Table B.18 or Table B.19 for the appropriate pipe size and wall thickness. Record the classification. Values for classification based on remaining outside diameter are given in Table C.4 (Table D.4) and Table C.5 (Table D.5).

10.13.8 Procedure for evaluating volumetric outside-surface pipe-body imperfections

10.13.8.1 General

This procedure is used when imperfections, such as pits, cuts and gouges, are found on the outside diameter of a length of used drill pipe. Pits, cuts, and gouges usually do not require probe grinding for depth measurement.

10.13.8.2 Measurement of imperfection depth

Adjust the depth gauge to zero on a flat surface. Measure the depth of the imperfection using a depth gauge. Before measurement, remove any material that can interfere with the measurement. Read the depth of the imperfection directly from the dial. The "zero point" of the gauge shall be reconfirmed after taking a reading that results in a downgrade.

If the normal pipe contour is irregular or has a dent, the depth gauge should be zeroed next to the imperfection with the plunger adjacent to the deepest point. Move the depth gauge to the other side and check the "zero"; if there is a difference, adjust the "zero" by half the difference. Then measure the depth of the imperfection.

10.13.8.3 Determination of average adjacent wall

Measure the wall thickness on each side of the imperfection adjacent to its deepest penetration using a properly standardized ultrasonic thickness gauge. The average of the two readings shall be the average adjacent wall.

10.13.8.4 Determine cut or gouge depth as a percentage of adjacent wall (required for slip-area cuts and gouges)

Divide the depth of the cut or gouge by the average adjacent wall and multiply the results by one hundred to calculate the cut or gouge depth as a percentage of the adjacent wall.

10.13.8.5 Determination of remaining wall thickness

Subtract the depth of the imperfection from the average remaining wall thickness.

10.13.8.6 Classification of outside-surface pipe-body imperfections**10.13.8.6.1 Cuts and gouges in the slip area**

Cuts and gouges in the slip area shall meet both the percent of adjacent wall requirements and the remaining wall requirements for slip-area cuts and gouges given in Tables B.18 and B.19. If the cut or gouge is transverse, the pipe cannot be classified as class 2 based on remaining wall, since the criteria for class 2 is the same as premium. Dimensional values for classification based on remaining wall are given in Table C.4 (Table D.4) for drill pipe and Table C.5 (Table D.5) for work-string tubing.

Conditions that downgrade pipe may be removed by grinding provided the remaining wall thickness meets the requirements for remaining wall due to wear and provided the grind is approximately blended into the outer contour of the pipe.

10.13.8.6.2 Cuts and gouges outside the slip area and full-length OD pits

The remaining wall thickness shall meet the requirements of Table B.18 and Table B.19 for each class. Dimensional values for classification based on remaining wall are given in Table C.4 (Table D.4) and Table C.5 (Table D.5).

The classification values in Tables C.4 and C.5 (Tables D.4 and D.5) are applied based on the following criteria.

- a) Remaining wall under corrosion shall be at least 80 % to be premium and 70 % to be class 2.
- b) Remaining wall under longitudinal cuts and gouges shall be at least 80 % to be premium and 70 % to be class 2.
- c) Remaining wall under transverse cuts and gouges shall be at least 80 % for both premium and class 2.

NOTE A transverse cut or gouge cannot be classified as class 2, since the criteria for class 2 are the same as for premium.

10.13.9 Procedure for evaluating volumetric inside-surface pipe-body imperfections

The procedure in this subclause is used when imperfections, such as corrosion pitting or erosion, are found on the inside diameter of a length of used drill pipe.

The imperfection shall be localized as accurately as possible using the tools available.

Search the area with an ultrasonic thickness gauge to determine the remaining wall thickness above the corrosion pitting or erosion. The ultrasonic thickness gauge used to evaluate imperfections on the inside

surface of the pipe shall meet the requirement of 9.5.2. The minimum wall-thickness reading shall be the remaining wall thickness.

Classify the pipe based on the requirements of Tables B.18 and B.19, using the appropriate internal category. Dimensional values for classification based on remaining wall are given in Tables C.4 and C.5 (Tables D.4 and D.5).

10.13.10 Evaluation of cracks

10.13.10.1 General

A crack is a single-line rupture of the pipe surface.

The rupture shall

- a) be of sufficient length that it is indicated by magnetic particles, or
- b) be identifiable by visual inspection of the outside of the tube and/or optical or ultrasonic shear-wave inspection of the inside of the tube.

10.13.10.2 Evaluation of cracks

Evaluation (further evaluation of an indication detected with a scanning system) is performed by magnetic-particle inspection, visual inspection or ultrasonic inspection in accordance with list item b) below. The OD is normally checked first since it is the easiest to examine. First, visually examine the area of the indication and, if no crack is found visually, use a coil or yoke and magnetic particles to re-inspect the area for crack indications. If a crack is found, classify the pipe as scrap. There is zero tolerance for cracks. A crack, regardless of depth, causes the pipe to be classified as scrap. Grinding to remove a crack indication is not permitted. If no crack is found on the OD, proceed with examination for inside-surface cracks. Visual/magnetic-particle and/or shear-wave ultrasonics, as follows, may be used for internal-surface crack evaluation.

- a) Visual/magnetic particle — After cleaning the area, dry magnetic particles can be placed in the suspect area (usually with a non-ferromagnetic trough) and a DC coil energized around the same area; the tube is then rotated. With an internal optical instrument and an adequate light source, a good evaluation can then be made.
- b) Shear-wave ultrasonics — A 2,25 MHz to 5,0 MHz, 6,0 mm to 12,0 mm (0.25 in to 0.5 in) angle-beam search unit with a wedge shall be used to generate shear waves in the pipe being evaluated. The refracted angle used is typically 45° but shall ensure intersection with the pipe's internal surface. When scanning for longitudinally oriented imperfections, the wedge shall be machine-contoured to the pipe's outer surface. Either a separate, portable flaw detector with an A-scan display or the instrumentation described in 10.10.2 may be used.
- c) The instrument shall be standardized using the reference standard described in 10.10.5. Standardization shall comply with 10.10.6.
- d) The area of the indication is scanned in the applicable orientation. Once a reflector is found, it is characterized as "two-dimensional" or "volumetric".

The following four characteristic differences between the ultrasonic signal from cracks and pits provide guidance in distinguishing cracks from pits.

- A crack is transverse in orientation and a pit is volumetric. Therefore, a fatigue crack reflects sound from only two directions whereas a pit usually reflects sound from all directions.

- A fatigue crack is usually radial (normal to the surface). The reflection from a fatigue crack generally has the same amplitude, as well as the same baseline position, from both sides. A pit almost never exhibits this characteristic.
- A reflection from a fatigue crack is usually a crisp, clean signal with a quick and uniform rise and fall time. A pit reflection is usually very rough and erratic with a fairly wide base.
- Generally, a thickness reading can indicate the presence of a pit whereas a fatigue crack cannot be detected with compression waves from the tube surface.

10.14 Tool joints

10.14.1 General

In 10.14 the box and pin tool-joint visual inspection is covered of bevels, seals, threads, shoulder flatness, weight code/grade markings and tool-joint outside diameter.

10.14.2 Description

This inspection covers the visual examination of the tool joint for mechanical damage and corrosion. In addition, the pin base markings and identification groove (if present) (see Figures 5 and 6) are checked to verify that the pipe is the correct weight code (Table C.4 or D.4) and grade (Table B.16). The inspection can be broken down into four main areas: outside surface, sealing shoulder, threads and inside diameter.

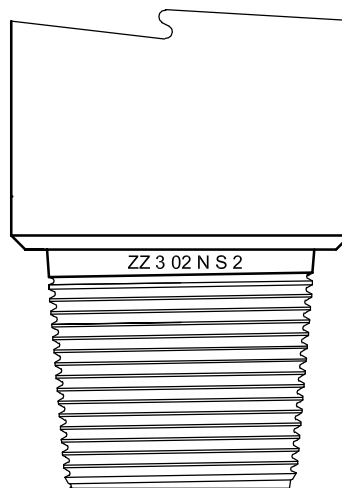
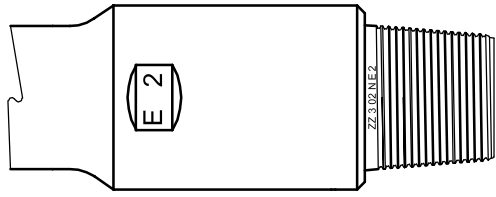
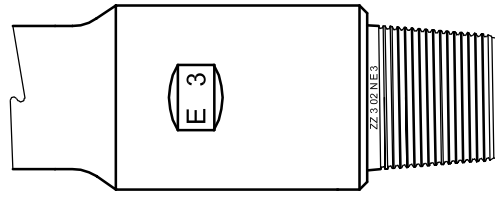

Figure 5 — Pin-base identification markings



a) Standard groove and mill-slot locations for E grade standard-weight drill pipe



b) Standard groove and mill-slot locations for E grade heavy-weight drill pipe

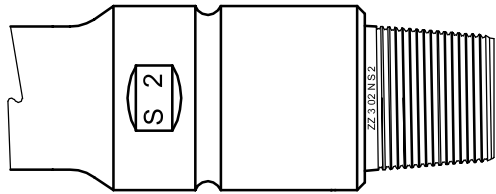

c) Standard groove and mill-slot locations for high-strength standard-weight drill pipe

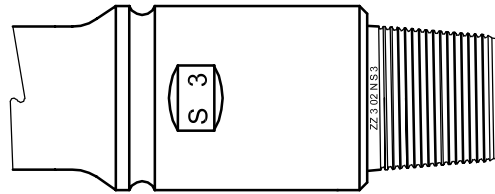

d) Standard groove and mill-slot locations for high-strength heavy-weight drill pipe

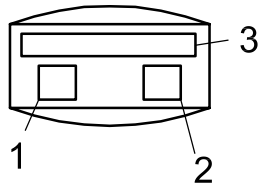

Key

- 1 mill slot location for pipe grade code
- 2 mill slot location for pipe weight code
- 3 mill slot location for optional serial number

Figure 6 — Tool-joint slot and groove marking system

10.14.3 Surface preparation

All surfaces being examined shall be cleaned so that foreign material does not interfere with the inspection process.

10.14.4 Equipment

A metal rule graduated in 0,5 mm (or 1/64 in) increments, a hardened and ground profile gauge and a lead gauge with proper setting standard and contacts are required. Inspection mirror and internal illumination equipment (portable light or mirror) are also required.

10.14.5 Calibration

Lead gauges shall be calibrated at least every six months and when they have been subjected to unusual shock that can affect the accuracy of the gauge.

10.14.6 Illumination

Illumination shall meet the requirements of 9.3.2.

10.14.7 Inspection procedure

Roll the drill stem product at least one revolution. Observe the seal, threads and bevel for signs of damage including but not limited to pits, cuts, dents, galling and other mechanical damage.

The sealing shoulders and threads shall be inspected for any abnormalities in the sealing face that result in any metal protrusions above the surface. Galling, dents and mashes can create this condition. Detection can be enhanced by rubbing a metal scale or fingernail across the surface.

The sealing shoulders shall be inspected for any depression in the surface that can cause the connection to leak.

At least a 0,79 mm (1/32 in) bevel shall be present for the full circumference. Any tool joint missing a portion of the bevel shall be re-bevelled or rejected.

Check shoulder flatness. Place a straightedge across the sealing shoulder on the box end or across a chord of the sealing shoulder on the pin. Rotate the straight edge and check for indications that the shoulder is not flat.

Thread-root surfaces shall be inspected for pits, cuts and gouges. All detected imperfections shall be evaluated according to 10.14.8.2.3.

A thread-profile gauge shall be used to inspect the condition of the thread profile of both the pin and box for wear. The inspector shall look for visible light between the gauge and the thread flanks, roots and crest. Two thread-profile checks 90° apart shall be made on each connection. All detected imperfections or gaps on the profile gauge shall be marked and evaluated according to 10.14.8.2.4.

Observe the tool-joint outside surface for signs of damage including but not limited to pits, cuts, dents, other mechanical damage and cracks. Place a straightedge along the outside diameter to check for signs of box swell. If the area near the bevel causes the straight edge to lift off, the counterbore diameter shall be checked in accordance with 10.15. Observe the tool-joint inside surface for signs of erosion or wear; if present, measure for maximum inside diameter according to 10.23.

Observe the pin-base marking, especially the weight code/grade markings on the pin base. Verify that markings are consistent with the pipe identified on the work order. See Figure 5, Tables B.16 and B.17, and Table C.4 (Table D.4), column 3, for pin-base stencil details. Missing marking shall be reported on the inspection report.

Observe the identification groove(s) and mill-slot markings on the tool-joint outside diameter. Verify that the markings are consistent with the pipe identified on the work order. See Figure 6 for tool-joint groove and mill-slot details.

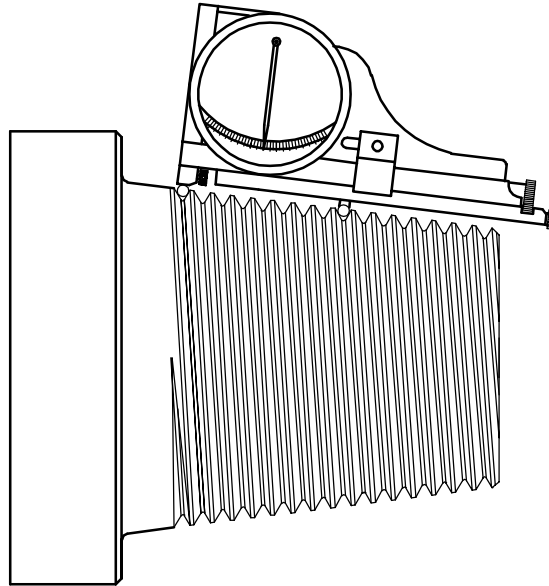

Figure 7 — Lead gauge check on pin threads

10.14.8 Evaluation and classification

10.14.8.1 Sealing shoulders

10.14.8.1.1 General

The shoulder face provides the only seal on a rotary shouldered connection. The following criteria apply to the different types of imperfections.

10.14.8.1.2 Protrusions

The sealing shoulders shall be inspected for any abnormalities in the sealing face that result in any metal protrusions above the surface. All faces with protrusions shall be rejected.

10.14.8.1.3 Shoulder flatness

Any visually detectable unflatness prevents further use of the tool joint until the problem is corrected.

10.14.8.1.4 Depressions

The sealing shoulders shall be inspected for any depression in the surface that can cause the connection to leak. Depressions that do not lie closer than 1,59 mm (0.062 in) to the OD bevel or the counterbore bevel are acceptable. Depressions that do not cover more than 50 % of the radial width of the seal surface nor extend more than 6,35 mm (0.025 0 in) in the circumferential direction are acceptable. All other depressions shall be rejected.

10.14.8.1.5 Re-facing of sealing faces

Faces that have been rejected for areas of fluid erosion, leaks, galls, fins, or metal that protrudes above the sealing surface shall be repaired by field re-facing or shall be removed from service. At each re-facing, a minimum amount of material shall be removed. The maximum removal of material shall be 0,79 mm (0.031 in) from a pin or box at any one re-facing and not more than 1,59 mm (0.062 in) cumulatively. If benchmarks or other evidence indicates that more than these limits have been removed, the connection shall be rejected.

After re-facing, the shoulders shall be checked for flatness. Place a straightedge across the sealing shoulder on the box end or across a chord of the sealing shoulder on the pin. Rotate the straight edge and check for any indications that the shoulder is not flat. Any visually detectable unflatness prevents further use of the tool joint until the problem is corrected.

NOTE Without benchmarks, determination of cumulative re-facing cannot be determined with certainty. There are two indicators that the maximum of 1,59 mm (0.006 in) has been exceeded on connections cut to ISO 10424-2 and API Spec 7-2.

- a) The length of the pin base at the first point of full depth thread exceeds 14,29 mm (0.562 in).
- b) The box counterbore is reduced to less than 14,29 mm (0.562 in).

Not exceeding these limits does not assure that the cumulative re-facing limit has not been exceeded.

After repair, the face shall be re-examined for compliance with the criteria of 10.14.7.

10.14.8.2 Thread surfaces

10.14.8.2.1 Protrusions

The thread surfaces shall be inspected for any protrusions of metal above the surface. Dents and mashes are typical causes of protrusions. All threads with protrusions shall be rejected. Surfaces rejected for protrusion may be repaired by filing with a soft grinding wheel. The thread profile shall be checked after any such filing and the requirements of 10.14.8.2.4 shall be met or the connection shall be removed from service.

10.14.8.2.2 Galling

All galled threads shall be rejected.

10.14.8.2.3 Pits, cuts and gouges

Pits, cuts and gouges that result in slight depressions in the flanks and crests of the threads are acceptable as long as they do not extend more than 38 mm (1.5 in) in length. Pits, cuts and gouges that are in the root of the thread are rejected if they are within two threads of the last engaged thread. Pits, cuts and gouges that are in the root of other threads cannot exceed 0,79 mm (0.031 in) in depth.

10.14.8.2.4 Thread profile

A thread profile gauge shall be used to inspect the condition of the thread profile of both the pin and box for wear. The inspector shall look for visible light between the gauge and the thread flanks, roots and crest. If the visible gap between the gauge and the thread crest is greater than 0,79 mm (0.031 in) over four consecutive threads or 1,5 mm (0.06 in) over two consecutive threads, the connection shall be rejected. Visible gaps between the gauge and the thread flanks estimated to be more than 0,4 mm (0.016 in) shall be cause for rejection. Any indication of stretching shall be evaluated by measuring the lead error as described in 10.15. Classification of stretching shall be in accordance with 10.15.6.2. All stretched pins shall be inspected for cracks in accordance with 10.21.

10.14.8.3 Outside- and inside-diameter surfaces

Outside and inside surfaces in areas other than hard-banding shall be free of visible cracks.

10.14.8.4 Weight code and grade identification markings

If present, the weight code and grade information on the pin base and the mill slot shall agree with each other or the pipe shall be rejected. If the markings do not agree with the work order, the pipe shall be marked as incorrect pipe and removed from the string. If no markings are present to identify weight code and grade, it shall be noted on the inspection report.

10.14.9 Repair of rejected tool joints

For repair of rejected tool joints, see 10.16.

10.15 Tool joints — Check for box swell and pin stretch

10.15.1 Description

Over-torque conditions are manifested as box swell or pin stretch, depending on which element is weaker in torsion. This check is to detect these over-torque conditions.

10.15.2 Surface preparation

All surfaces being examined shall be cleaned so that foreign material does not interfere with the inspection process.

10.15.3 Equipment

A 250 mm metal rule with 0,5 mm divisions (or a 12 in rule with 1/64 in divisions), OD callipers, a lead gauge capable of measuring from the point of the last full depth thread (see Figure 14) with the proper contacts and a lead-setting standard for the pitch and taper of the threads being inspected are required. A dial calliper is optional. Metal rule and dial calliper shall meet the requirements of 9.2.2. Ball contact sizes for the lead gauge and for setting the standard compensation length for measuring parallel to the pitch cone are given in Table C.3 (Table D.3).

10.15.4 Lead-gauge calibration

The accuracy of the lead gauge shall be checked on a precision screw micrometer or other device capable of measuring in 0,003 mm (0.000 1 in). Determine the amount of micrometer movement necessary to indicate an error of 0,025 mm (0.001 in) by the lead gauge for each 0,025 mm (0.001 in) of the lead-gauge scale. From these determinations, prepare a table of accumulative error for the entire scale range of the lead gauge.

For lead gauges, the accuracy of interval measurements and repeated readings shall be within 0,005 mm (0.000 2 in).

Lead gauges shall be calibrated at least every six months, and when they have been subjected to unusual shock that can affect the accuracy of the gauge.

10.15.5 Standardization

10.15.5.1 Illumination

Illumination shall meet the requirements of 9.3.2.

10.15.5.2 Lead gauge

Before use, the distance between ball contacts shall be set at 51 mm (2 in), and the indicator set to the zero position when the gauge is applied to the proper setting of the standard template. A gauge is zeroed when the null point is zero when the gauge is pivoted upon the fixed ball point through a small arc on either side of the correct line of measurement.

10.15.5.3 Frequency of standardization

Standardization of the lead gauge shall be performed at the beginning of each job.

Periodic standardization checks shall be performed as follows:

- a) at the beginning of each inspection shift;
- b) at least every 25 ends measured or inspected in a continuous operation;

- c) whenever there is a change of operator (inspector);
- d) after the last connection has been inspected;
- e) whenever a reject reading is encountered;
- f) prior to resuming operation after repair or change to the gauge.

10.15.5.4 Unacceptable checks

All pipe inspected between an unacceptable check and the most recent acceptable check shall be re-inspected.

10.15.6 Inspection procedure

10.15.6.1 Box swell

Using a precision rule or dial calliper, measure the counterbore diameter, Q_c , at two places approximately 90° apart (see Figure 10). The measurement is made from the projected intersection of the counterbore with the box face rather than to the internal bevel. Diameters shall not exceed the values listed in Table C.7 (Table D.7).

As an additional check, the outside diameter may be checked to detect box swell. Use caution, as down-hole OD wear can make this method unreliable. Measure the OD using callipers at the OD bevel and then measure the OD 51 mm (2 in) away from the bevel. If the OD at the bevel is greater by 0,79 mm (1/32 in) or more, the connection shall be rejected.

10.15.6.2 Pin stretch

Using the lead gauge, place the movable contact in the last full-depth thread near the sealing shoulder (see Figure 7) and the fixed contact in the groove at the appropriate distance. Make sure the movable contact is in contact with the thread flanks. The gauge shall be pivoted about the fixed contact in a small arc on either side of the correct line of measurement. The minimum fast (+) or maximum slow (–) reading is the lead error. A second measurement shall be taken after moving the lead gauge approximately 90° counter-clockwise. Lead measurements shall not exceed + 0,152 mm (0.006 in) in 50,8 mm (2 in).

10.15.7 Evaluation and classification

All stretched pins shall be magnetic-particle inspected in accordance with 10.21. Threads containing cracks shall be rejected. This requirement includes pins stretched less than 0,0152 mm (0.006 in).

Pins having lead measurements that exceed 0,152 mm (0.006 in) in 50,8 mm (2 in) shall be rejected.

10.16 Repair of rejected tool joints

Shop repair and return to service of some rejected tool-joint connections can be possible if the unaffected area of the tool-joint body permits and all other criteria, such as minimum tong space, are met. Areas containing cracks shall be cut off prior to repair. All recut connections shall meet requirements for new connections and shall be magnetic-particle inspected in accordance with 10.21 for pin recuts and 10.22 for box recuts.

10.17 Tool joints — Check tool-joint pin and box outside diameter and eccentric wear

10.17.1 Description

The outside diameter of the box tool joint is the controlling factor for box tool-joint torsional strength. The minimum outside diameter for each class is the tool-joint diameter that is required for the box tool joint to have 80 % of the torsional strength of a pipe with the minimum wall for that class. Pin outside diameters shall meet

the same criteria. The box shoulder is visually checked for eccentric wear and minimum shoulder width is checked if eccentric wear is evident.

10.17.2 Surface preparation

All surfaces being examined shall be cleaned so that foreign material does not interfere with the detection process.

10.17.3 Equipment

A 250 mm metal rule with 0,5 mm divisions (or a 12 in rule with 1/64 in divisions) and OD callipers are required. A dial calliper may be substituted for the metal rule. The metal rule and dial calliper shall meet the requirements of Clause 9. An additional straightedge is required to check eccentricity wear on box shoulders.

10.17.4 Standardization

10.17.4.1 Illumination

Illumination shall meet the requirements of 9.3.2.

10.17.4.2 Standardization

Using the metal rule or dial calliper, set the OD callipers to the minimum tool-joint outside diameter for premium class for the pipe size, grade and connection as found in Table C.6 (Table D.6).

10.17.4.3 Frequency of standardization

Standardization of the OD calliper shall be performed at the beginning of each job.

Periodic standardization checks shall be performed as follows:

- a) at the beginning of each inspection shift;
- b) at least every 25 ends measured or inspected in a continuous operation;
- c) whenever there is a change of operator (inspector);
- d) after the last connection has been inspected;
- e) whenever a downgrade reading is encountered;
- f) prior to resuming operation after repair or change to the calliper.

10.17.4.4 Unacceptable checks

All pipe inspected between an unacceptable check and the most recent acceptable check shall be re-inspected.

10.17.5 Inspection procedure

Visually check the box shoulder for eccentric wear. If the tool joint is eccentrically worn, the minimum shoulder shall be evaluated according to 10.17.6.2.

Check the tool-joint outside diameter approximately 25 mm (1.0 in) from the sealing shoulder, on both the box and pin, to ensure that the outside diameter is equal to or larger than the minimum for premium class; see Table C.6 (Table D.6).

The outside diameter for each end shall be checked in at least two places approximately 90° apart.

Tool joints not meeting the requirements for premium class shall be evaluated in accordance with 10.17.6.

10.17.6 Evaluation and classification

10.17.6.1 Outside diameter

Tool joints failing to meet the requirements for premium class shall be measured to determine the minimum outside diameter approximately 25 mm (1.0 in) from the sealing shoulder. The minimum diameter shall be recorded on the inspection work sheet and the tool joint classified based on the requirements of Table C.6 (Table D.6).

NOTE Tool joints with less than the minimum outside diameter can be usable as long as the torque restriction is observed.

10.17.6.2 Eccentric wear

Box tool joints with visual eccentricity require the minimum shoulder width. Shoulder width is measured from a projection of the outside diameter surface to a projection of the counterbore at the plane of the 90° shoulder (see Figure 8, S_w). Tool joints with a shoulder width less than the minimum for premium shall be downgraded to class 2, provided the shoulder width meets the minimum for class 2; otherwise, the tool joint shall be classified class 3. Minimum shoulder widths are shown in Table C.6 (Table D.6).

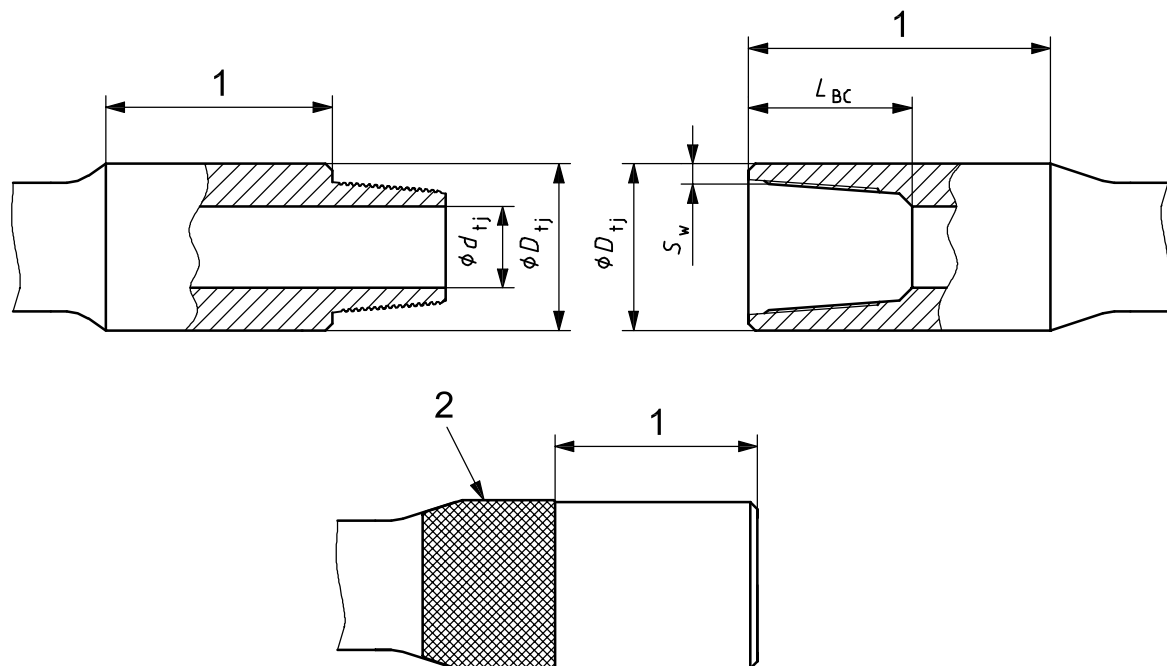

Key

- 1 tong space
- 2 hard-banding

Figure 8 — Tool-joint classification measurements

10.18 Tool joints — Measure tool-joint pin and box outside diameter and check for eccentric wear

10.18.1 Description

The outside diameter of the box tool joint is the controlling factor for box tool joint torsional strength. The minimum outside diameter for premium and class 2 are based on a tool-joint-to-pipe torsional ratio of at least 80 %. The minimum wall values for each class of pipe are used to calculate the pipe torsional strength. Pin outside diameters shall meet the same criteria. The box and pin outside diameters are measured and the values recorded on the inspection work sheet. The box shoulder is visually checked for eccentric wear and minimum shoulder width is measured if eccentric wear is evident.

10.18.2 Surface preparation

All surfaces being examined shall be cleaned so that foreign material does not interfere with the detection process.

10.18.3 Equipment

A 250 mm metal rule with 0,5 mm divisions (or a 12 in rule with 1/64 in divisions) and OD callipers are required. A dial calliper may be substituted for the metal rule. Metal rule and dial calliper shall meet the requirements of 9.2.2 and 9.2.3. An additional straightedge is required to check eccentricity wear on box shoulders.

10.18.4 Illumination

Illumination shall meet the requirements of 9.3.2.

10.18.5 Inspection procedure

Visually check the box shoulder for eccentric wear. If the tool joint is eccentrically worn, the minimum shoulder shall be evaluated according to 10.18.6.

Search the tool-joint outside diameter for the minimum diameter approximately 25 mm (1.0 in) from the sealing shoulder, on both the box and pin tool joint, using the OD callipers. When the minimum outside diameter is found, adjust the callipers until they are sized to the minimum diameter.

Using the metal rule or callipers, measure the distance between the contacts on the calliper.

10.18.6 Evaluation and classification

The minimum outside diameter shall be recorded on the inspection work sheet and the tool joint classified based on the highest classification standard that it meets according to Table C.6 (Table D.6).

NOTE Tool joints with less than the minimum outside diameter can be usable as long as the torque restriction is observed.

Box tool joints with visual eccentricity require measurement of the minimum shoulder width. Shoulder width is measured from a projection of the outside diameter surface to a projection of the counterbore at the plane of the 90° shoulder (see Figure 8, S_w). Tool joints with a shoulder width less than the minimum for premium shall be downgraded to class 2 provided the shoulder width meets the minimum for class 2; otherwise, the tool joint shall be classified class 3. Minimum shoulder widths are shown in Table C.6 (Table D.6).

10.19 Tool joints — Check tool-joint pin and box tong space

10.19.1 Description

The criteria for determining the minimum tong space for tool joints on used drill pipe should be based on safe and effective tonging operations on the rig floor, primarily when manual tongs are in use. In this regard, there should be sufficient tong space to allow full engagement of the tong dies, plus an adequate amount of tong space remaining to allow the driller and/or floorhand to visually verify that the mating shoulders or the connection are unencumbered to allow proper make-up or break-out of the connection without damage. The minimum tong space requirements provided in this part of ISO 10407 are based on manual tong applications.

It is also recommended that any hard-banded surfaces of the pin or box tool-joint tong space be excluded from the area of tong-die engagement, as stated above, when minimum tong space is determined. This practice ensures that optimum gripping of the tongs is achieved and that damage to tong dies is minimized. In cases where tool-joint diameters have been worn to the extent that the original hard-banding has been substantially removed, the user may include this area in determining the minimum tong space.

The use of other types of tongs or devices designed for the purpose of making and breaking connections may require a minimum tong space different from those shown here for manual tongs. In this case, minimum tong spaces shall be determined by agreement with the owner/user. The user shall provide the criteria necessary to ensure that the intent of this recommendation is satisfied.

10.19.2 Surface preparation

All surfaces being examined shall be cleaned so that foreign material does not interfere with the measurement process.

10.19.3 Equipment

A 250 mm metal rule with 0,5 mm divisions (or a 12 in rule with 1/64 in divisions) is required for the inspection.

10.19.4 Illumination

Illumination shall meet the requirements of 9.3.2.

10.19.5 Inspection procedure

Check that the tong space on the box tool joint from the plane of the tool-joint face to the corner of the tapered shoulder and the outside diameter of the tool joint meets or exceeds the minimum tong-space length. If hard-banding is present, check from the plane of the tool-joint face to the edge of the hard-banding nearest the tool-joint face (see Figure 8).

Check that the tong space on the pin tool joint from the plane of the tool-joint face to the corner of the tapered shoulder and the outside diameter of the tool joint meets or exceeds the minimum tong-space length. If hard-banding is present, check from the plane of the tool-joint face to the edge of the hard-banding nearest the tool-joint face (see Figure 8).

10.19.6 Evaluation and classification

If user-specified criteria are not provided, the minimum tong space for pin tool joints shall be 75 % of the tool-joint outside diameter but not less than 102 mm (4 in), and the box tong space shall not be less than L_{BC} [see Table C.7 (Table D.7)] plus 25 mm (1 in). Tool joints not meeting the minimum tong-space requirement agreed to by the owner/user shall be rejected.

10.20 Tool joints — Measure tool-joint pin and box tong space

10.20.1 Description

The criteria for determining the minimum tong space for tool joints on used drill pipe should be based on safe and effective tonging operations on the rig floor, primarily when manual tongs are in use. In this regard, there should be sufficient tong space to allow full engagement of the tong dies, plus an adequate amount of tong space remaining to allow the driller and/or floorhand to visually verify that the mating shoulders or the connection are unencumbered to allow proper make-up or break-out of the connection without damage. The minimum tong space requirements provided in this part of ISO 10407 are based on manual tong applications.

It is also recommended that any hard-faced (hard-banded) surfaces of the pin or box tool-joint tong space be excluded from the area of tong-die engagement as stated above when minimum tong space is determined. This practice ensures that optimum gripping of the tongs is achieved and that damage to tong dies is minimized. In the case where tool joint diameters have been worn to the extent that the original hard-banding has been substantially removed, the user may include this area in determining the minimum tong space.

The use of other types of tongs, or devices designed for the purpose of making and breaking connections can require a minimum tong space different from those shown for manual tongs. In this case, minimum tong spaces shall be determined by agreement with the owner/user. The user shall provide the criteria necessary to ensure that the intent of this recommendation is satisfied.

10.20.2 Surface preparation

All surfaces being examined shall be cleaned so that foreign material does not interfere with the measurement process.

10.20.3 Equipment

A 250 mm metal rule with 0,5 mm divisions (or a 12 in rule with 1/64 in divisions) is required for the inspection.

10.20.4 Illumination

Illumination shall meet the requirements of 9.3.2.

10.20.5 Inspection procedure

Measure the tong space on the box and pin tool joint from the plane of the tool-joint face to the corner of the tapered shoulder and the outside diameter of the tool joint (see Figure 8). If hardbanding is present, measure from the plane of the tool-joint face to the edge of the hardbanding nearest the tool-joint face. The tong space for both the pin and box shall be recorded on the inspection work sheet.

The action required to classify is covered in 10.20.6.

10.20.6 Evaluation and classification

If user-specified criteria are not provided, the minimum tong space for pin tool joints shall be 75 % of the tool-joint outside diameter but not less than 102 mm (4 in) and the box tong space shall not be less than L_{BC} [see Table C.7 (Table D.7)] plus 25 mm (1 in). Tool joints not meeting the tong-space requirement agreed to by the owner/user shall be rejected.

10.21 Tool joint — Magnetic-particle inspection of the pin threads

10.21.1 General

In 10.21 the equipment requirements, descriptions and procedures are provided for wet fluorescent-magnetic-particle inspection of the external surface of the pin thread area on used drill-pipe tool joints. This inspection is performed to detect transverse cracks in the thread roots with special attention to the last engaged thread.

The thread area is from the small end of the pin up to and including the pin base.

10.21.2 Equipment

10.21.2.1 Longitudinal field

A coil, either AC or DC (HWAC, FWAC or filtered FWAC or pulsating DC), may be used for this inspection. The number of turns of the coil shall be clearly marked on the coil.

10.21.2.2 Fluorescent-particle inspection

Fluorescent-magnetic-particle solutions shall comply with the requirements of 9.4.8.3. An ultraviolet light source, fluorescent magnetic particles, a 100 ml centrifuge tube (graduated in 0,05 ml increments) and an ultraviolet light meter are required. If the particles are supplied as an aerosol, the centrifuge tube is not required.

10.21.2.3 Additional equipment

Additional equipment includes a magnetometer or gauss meter.

10.21.3 Illumination

Illumination of the surfaces for fluorescent-magnetic-particle inspection shall comply with the requirements of 9.4.8.5.

10.21.4 Surface preparation

The inspection areas shall be cleaned of all grease, thread compound, dirt and any other foreign matter that can interfere with particle mobility, complete wetting of the surface by the particle carrier and indication detection.

Surface coatings, such as anti-gall treatment, shall be smooth and shall have a thickness equal to or less than 0,05 mm (0.002 in).

10.21.5 Calibration

Equipment calibration is covered in Clause 9.

10.21.6 Standardization

10.21.6.1 Ultraviolet-light intensity check

Verify the intensity of the ultraviolet light under working conditions. The intensity at the surface shall be at least 1 000 $\mu\text{W}/\text{cm}^2$.

10.21.6.2 DC coil or pulsating DC coils

Select a typical tool joint from the string for inspection. Place the DC coil over the tool joint near the sealing shoulder. Energize the coil to establish a residual longitudinal field. Using the residual field, apply the magnetic particles to the inspection area and observe the particle mobility. If the magnetic particles continue to flow for longer than 10 s, increase the magnetic field strength and reapply magnetic particles. If the magnetic particles are pulled out of suspension prematurely, i.e. within an interval shorter than 6 s, reverse the coil and apply slightly less current. Continue until the magnetic particle mobility is from 6 s to 10 s after application.

After the proper magnetic field has been established based on particle mobility, measure the field at the end of the connection using a gauss meter or magnetometer. The field in each subsequent connection shall be within 10 % of the established field strength.

NOTE Excessive ampere-turns (NI) can cause a lack of mobility of the wet particles that results in increased background noise and reduced indication brightness.

10.21.6.3 AC coil

Select a typical pipe from the string for inspection. Place the coil on the pipe near the sealing shoulder. Energize the coil and apply magnetic-particle solution on both sides of the coil in the appropriate ultraviolet light conditions and observe the distance over which the particles have definitive movement due to the magnetic field [normally 76 mm (3 in) to 102 mm (4 in)]. This distance becomes the inspection distance for each placement of the AC coil. Multiple coil placements on the threads can be required.

10.21.7 Inspection procedures

The steps for inspection found in this subclause are the minimum requirements and can vary depending upon the drill-pipe condition and the options agreed to between the owner and the agency. Visible-light inspection of the threads as described in 10.14 is required prior to the ultraviolet-light inspection.

The following steps are conducted in a darkened area (21,5 lx maximum visible light). The inspector shall be in the darkened area at least 1 min prior to beginning inspection to allow the eyes to adapt. Darkened lenses or photochromic lenses shall not be worn.

Place the coil on the pin shoulder being inspected. For the DC coil, this placement should provide an adequate magnetic field to cover the entire thread area. For the AC coil, the distance established in 10.21.6.2 is the maximum inspection distance. Multiple placements can be required to inspect the entire pin length.

For DC coils, energize the coil with the magnetizing current at the level established during standardization for at least 1 s. Turn the coil off. Move the coil out of the way and measure the field at the end of the tool joint as specified in 10.21.6.2. Adjust the coil as necessary to establish a proper field. For AC coils, the inspection shall be done with an active field.

Apply the particle bath by gently spraying or flowing the suspension over the threads. Using the ultraviolet light, and in a suitably darkened area, examine the threaded area completely around the pipe, paying particular attention to the root of the last engaged thread. Reapplication of particles is required when the section that was on the bottom is rolled to the top.

For AC coils, displace the coil to cover any additional area and repeat 10.21.6.3.

Repeat the process with at least a 25 mm (1.0 in) overlap until the entire area being inspected has been covered.

Magnetic particles and cleaning materials shall be removed after inspection.

10.21.8 Evaluation and classification

All tool-joint threads containing a crack, regardless of depth, shall be rejected.

If it is necessary to distinguish cracks from machining marks in the thread roots, a high-speed, soft wheel may be used to buff the indication. Buffing shall not be used to remove cracks.

10.21.9 Repair of rejected tool joints

For repair of rejected tool joints, see 10.16.

10.22 Tool joint — Magnetic-particle inspection of box threads

10.22.1 General

This inspection is performed to detect transverse cracks in the thread roots with special attention to the last engaged thread.

The box threaded area is from the large end of the counterbore to the end of the thread root in the small end of the box.

10.22.2 Equipment

10.22.2.1 Longitudinal field

A DC (HWAC, FWAC or filtered FWAC or pulsating DC) coil shall be used for this inspection. The number of turns of the coil shall be clearly marked on the coil.

10.22.2.2 Fluorescent-particle inspection

Fluorescent-magnetic-particle solutions shall comply with the requirements of 9.4.8.3. An ultraviolet light source, fluorescent magnetic particles, a 100 ml centrifuge tube (with 0,05 ml increments) and an ultraviolet light meter are required. If the particles are supplied as an aerosol, the centrifuge tube is not required.

10.22.2.3 Additional equipment

Additional equipment includes a magnetometer (or gauss meter).

10.22.3 Illumination

Illumination of the surfaces for fluorescent-magnetic-particle inspection shall comply with the requirements of 9.4.8.5.

10.22.4 Surface preparation

The inspection areas shall be cleaned of all grease, thread compound, dirt and any other foreign matter that can interfere with particle mobility, complete wetting of the surface by the particle carrier and indication detection.

Surface coatings, such as anti-gall treatment, shall be smooth and shall have a thickness equal to or less than 0,05 mm (0.002 in).

10.22.5 Calibration

Equipment calibration is covered in Clause 9.

10.22.6 Standardization

Select a typical tool joint from the string for inspection. Place the DC coil over the tool joint near the threaded area. Energize the coil as specified in Table C.1 (Table D.1) based on the outside diameter of the box connection. Using the residual field, apply the magnetic particles to the thread area and observe the particle mobility. Adjust field as high as possible without the magnetic particles being prematurely pulled out of suspension in the threaded area. Particle mobility should continue for at least 6 s.

After the proper magnetic field has been established based on particle mobility, measure the field at the end of the connection using a gauss meter or magnetometer. The field in each subsequent connection shall be within 10 % of the established field strength.

10.22.7 Inspection procedures

The steps for inspection found in this subclause are the minimum requirements and can vary depending on the drill-pipe condition and the options agreed to between the owner and the agency. Visible-light inspection of the threads as described in 10.14 is required prior to the ultraviolet-light inspection.

The following steps are conducted in a darkened area (21,5 lx maximum visible light). The inspector shall be in the darkened area at least 1 min prior to beginning the inspection to allow the eyes to adapt. Darkened lenses or photochromic lenses shall not be worn.

For the box, place the coil over the tool joint over the threaded area. Energize the coil with the magnetizing current at the level established during standardization for at least 1 s. Turn the coil off. Measure the field at the end of the tool joint as specified by the criteria established in 10.22.6. Adjust the coil as necessary to establish the proper field.

Apply the magnetic particle bath by gently spraying or flowing the suspension over the threads. Using ultraviolet light, examine the threaded area on the top half of the connection using a mirror to examine the thread roots, paying particular attention to the root of the last engaged thread. Rotate the tool joint 180° and reapply the particles. Using ultraviolet light, examine the threaded area on the top half of the connection using a mirror to examine the thread roots, paying particular attention to the root of the last engaged thread.

Remove magnetic particles after inspection.

10.22.8 Evaluation

All tool-joint threads containing a crack, regardless of depth, shall be rejected.

If it is necessary to distinguish cracks from machining marks in the thread roots, a high-speed, soft wheel may be used to buff the indication. Buffing shall not be used to remove cracks.

10.22.9 Repair of rejected tool joints

For repair of rejected tool joints, see 10.16.

10.23 Tool joints — Measure tool-joint pin inside diameter

10.23.1 Description

The inside diameter of the tool joint is the controlling factor for pin tool-joint torsional strength. The maximum inside diameter is the basis for the tool-joint pin to meet the tool-joint-to-pipe torsional ratios of at least 80 %. Pipe torsional values are based on the minimum wall values for the pipe in the respective class. As new tool-joint inside diameters normally meet the higher 80 % requirement for new pipe, and inside diameters normally do not change, this check is typically done only if a problem is detected visually or for critical service.

10.23.2 Surface preparation

All surfaces being examined shall be cleaned so that foreign material does not interfere with the detection process.

10.23.3 Equipment

A 250 mm metal rule with 0,5 mm divisions (or a 12 in rule with 1/64 in divisions) and ID callipers are required. A dial calliper may be substituted for the metal rule. Metal rule and dial calliper shall meet the requirements of 9.2.2 and 9.2.3.

10.23.4 Illumination

Illumination shall meet the requirements of 9.3.2.

10.23.5 Inspection procedure

Visually check the inside diameter for wear, erosion or other conditions affecting the diameter.

Check the inside diameter with the callipers at any area of inside-diameter increase. If no area of increase is present, check the diameter at a typical area approximately under the last full-depth thread (see Figure 8).

Using the metal rule or callipers, measure the distance between the contacts on the calliper.

10.23.6 Evaluation and classification

The maximum inside diameter shall be recorded on the inspection work sheet and the tool joint classified based on the highest classification standard that it meets according to Table C.6 (Table D.6) (see Figure 8).

10.24 Magnetic-particle inspection of the connection OD for heat-check cracking

10.24.1 General

The entire outside surface of the pin and box tool joint excluding any hard-banding area is inspected for longitudinal indications. Tool joints and other down-hole equipment that are rotated under high lateral force against the formation can be damaged as a result of friction heat checking. If the radial thrust load is sufficiently high, surface heat checking can occur in the presence of drilling mud. The steel is alternately heated and quenched as it rotates. This action produces numerous irregular heat-check cracks, often accompanied by longer axial cracks sometimes extending through the full section of the tool joint.

10.24.2 Equipment

10.24.2.1 Transverse field

Use an AC yoke with articulated legs for this inspection.

10.24.2.2 Dry magnetic particles

Dry magnetic particles shall meet the requirements of 9.4.8.2. A powder bulb, capable of applying magnetic particles in a light dusting, shall be used.

10.24.3 Illumination

Illumination of the inspection surfaces for visual inspection and visible-light magnetic-particle inspection shall comply with the requirements of 9.3.2.

10.24.4 Surface preparation

The inspection areas shall be cleaned of all grease, thread compound, dirt and any other foreign matter that can interfere with particle mobility and indication detection. All surfaces being inspected shall be powder dry.

Surface coatings (paint, etc.) shall be smooth and shall have a thickness equal to or less than 0,05 mm (0.002 in).

10.24.5 Calibration

Equipment calibration is covered in Clause 9.

10.24.6 Standardization

10.24.6.1 AC Yoke

Select a typical tool joint from the string for inspection and adjust the legs of the yoke to maximize contact with the tool-joint surface when positioned transversely to the tool-joint axis.

10.24.6.2 Inspection procedures

The steps for inspection found in 10.24.6 are the minimum requirements and can vary depending upon the drill-pipe condition and the options agreed to between the owner and the agency.

Perform the inspection in a lighted area (538 lx minimum visible light) as follows. Darkened lenses or photochromic lenses shall not be worn.

- a) Place the yoke transversely across the connection OD approximately 12,7 mm (0.5 in) from the shoulder.
- b) Energize the yoke and, while the current is on, apply the dry magnetic particles in a light cloud at near-zero velocity between the legs of the yoke.
- c) Allow at least 3 s for indications to form and then examine the area while still applying the current.

If no indication is found, turn off the yoke and move it, allowing for proper overlap, and repeat steps a) to c). Continue to inspect and move until the entire OD surface on tool joints, or a distance of 254 mm (10.0 in) from the shoulder for other down-hole drill stem elements, excluding hard-banding, has been inspected.

Both the pin and box tool-joint outside diameters shall be inspected.

10.24.7 Evaluation and classification

Any heat-check cracking within 50 mm (2 in) of the box sealing shoulder or deeper than 0,5 mm (0.020 in) are non-repairable and shall be cause for rejection. Heat-check cracking equal to or less than 0,5 mm (0.020 in) deep shall be removed or the tool joint shall be rejected.

10.25 Bi-directional wet magnetic-particle inspection of the connection OD for heat-check cracking

10.25.1 General

The entire outside surface of the pin and box tool joint, excluding any hard-banding area, is inspected for transverse and longitudinal indications. Tool joints and other down-hole equipment that are rotated under high lateral force against the formation can be damaged as a result of friction heat checking. If the radial thrust load is sufficiently high, surface heat checking can occur in the presence of drilling mud. The steel is alternately heated and quenched as it rotates. This action produces numerous irregular heat-check cracks often accompanied by longer axial cracks, sometimes extending through the full section of the tool joint.

10.25.2 Equipment

10.25.2.1 Longitudinal field

An AC yoke or a coil, either AC or DC (HWAC, FWAC or filtered FWAC or pulsating DC), may be used for this inspection. The number of turns of the coil shall be clearly marked on the coil.

10.25.2.2 Transverse/circular field

An AC yoke or internal conductor may be used. The current for the internal conductor may be supplied with DC, a three-phase rectified AC power supply or capacitor-discharge power supply. The power supply shall be capable of meeting the amperage requirements of Table C.2 (Table D.2). Table C.17 (Table D.17) provides the mass per metre (foot) for various tool-joint outside and inside diameter combinations. Table C.18 (Table D.18) provides the mass per metre (foot) for various outside and inside diameter combinations for drill collars.

10.25.2.3 Wet magnetic particles

10.25.2.3.1 Fluorescent-particle inspection

Fluorescent-magnetic-particle solutions shall comply with the requirements of 9.4.8.3. An ultraviolet light source, fluorescent magnetic particles, a 100 ml centrifuge tube (graduated in 0,05 ml increments) and an ultraviolet light meter are required. If the magnetic particles are supplied as an aerosol, the centrifuge tube is not required.

10.25.2.3.2 White background and black magnetic particles

White background and black magnetic-particle wet-inspection aerosol materials shall be from the same manufacturer, or specified as compatible by the product manufacturer and used in accordance with the manufacturer's requirements.

10.25.2.4 Additional equipment

A magnetometer or gauss meter is required if a DC coil is used for magnetization.

10.25.3 Illumination

Illumination of the inspection surfaces for visual inspection and visible-light black magnetic-particle inspection shall comply with the requirements of 9.3.2. Illumination of the surfaces for fluorescent-magnetic-particle inspection shall comply with the requirements of 9.4.8.5.

10.25.4 Surface preparation

The inspection areas shall be cleaned of all grease, thread compound, dirt and any other foreign matter that can interfere with particle mobility, complete wetting of the surface by the particle carrier and indication detection.

Surface coatings (paint, etc.), including white background coating if a white background and black magnetic particle system is used, shall be smooth and shall have a thickness equal to or less than 0,05 mm (0.002 in).

10.25.5 Calibration

Equipment calibration is specified in Clause 9.

10.25.6 Standardization

10.25.6.1 AC yoke

Select a typical pipe from the string for inspection and adjust the legs of the yoke to maximize contact with the pipe surface when positioned for the appropriate inspection direction.

10.25.6.2 DC coils

Select a typical tool joint from the string for inspection. Place the DC coil over the tool joint near the centre of the tool joint. Energize the coil to establish a residual longitudinal field. Using the residual field, apply the magnetic particles to the inspection area and observe the particle mobility. If the magnetic particles continue to flow for longer than 10 s, increase the magnetic field strength and reapply magnetic particles. If the magnetic particles are pulled out of suspension prematurely, i.e. within an interval shorter than 6 s, reverse the coil and apply slightly less current. Continue until the magnetic particle mobility is from 6 s to 10 s after application.

After the proper magnetic field has been established based on particle mobility, measure the field at the end of the connection using a gauss meter or magnetometer. The field in each subsequent connection shall be within 10 % of the established field strength.

10.25.6.3 AC coils

Select a typical pipe from the string for inspection. Place the coil on the pipe near the centre of the tool joint. Energize the coil and apply the magnetic-particle solution on both sides of the coil in the appropriate ultraviolet light conditions and observe the distance over which the particles have a definitive movement due to the magnetic field [normally 76 mm (3 in) to 102 mm (4 in)]. This distance becomes the inspection distance for each placement of the AC coil. Multiple coil placements on the threads can be required.

10.25.6.4 Magnetizing rod

The magnetizing rod shall be completely insulated from the part being inspected. Power-supply requirements in Table C.2 (Table D.2) shall be met based on the mass per metre (foot) of the tool joint. The current level specified in the table shall be the magnetizing current for the longitudinal inspection. Table C.17 (Table D.17) provides the mass per metre (foot) for various tool-joint outside and inside diameter combinations. Table C.18 (Table D.18) provides the mass per metre (foot) for various outside and inside diameter combinations for drill collars.

10.25.7 Inspection procedures

10.25.7.1 General

The inspection area shall be inspected with both a longitudinal and transverse/circular magnetic field using one of the procedures in 10.25.7.2 or 10.25.7.3 for each. The steps for inspection found in 10.25.7 are the minimum requirements and can vary depending upon the drill-pipe condition and the options agreed to between the owner and the agency.

10.25.7.2 Fluorescent method

10.25.7.2.1 General

The following steps are conducted in a darkened area (21,5 lx maximum visible light). The inspector shall be in the darkened area at least 1 min prior to beginning inspection to allow the eyes to adapt. Darkened lenses or photochromic lenses shall not be worn.

10.25.7.2.2 Yoke

The longitudinal inspection may be done with the yoke, as described in this subclause, or using a magnetizing rod and DC power supply (see 10.25.7.2.4). With the tool joint in a darkened area, place the yoke transversely across the tool-joint OD approximately 12,7 mm (0.5 in) from shoulder. Energize the yoke and, while the current is on, apply the particle bath by gently spraying or flowing the magnetic-particle bath over the tool-joint OD in the magnetized area. Allow at least 3 s for indications to form and then, while still applying the current, use ultraviolet light to examine the area.

If no indication is found, turn off the yoke and move it, allowing for proper overlap, and repeat the above procedure. Continue to inspect and move until the entire OD surface on tool joints, or a distance of 254 mm (10 in) from the shoulder for other down-hole drill stem elements, excluding hard-banding, has been inspected for longitudinal indications.

Transverse inspection may be done with the yoke, as described in this subclause, or using a coil (see 10.25.7.2.3). Inspect the entire area with the legs of the yoke placed longitudinally, following the same procedures as above. Apply the particle bath by gently spraying or flowing the suspension over the tool-joint OD in the magnetized area. Allow at least 3 s for indications to form and then examine the area using ultraviolet light. Continue to inspect and move until the entire OD surface of the inspection area has been inspected for transverse indications.

10.25.7.2.3 Coil

With the tool joint in a darkened area, place the coil over the tool-joint OD approximately in the middle of the tool joint. Magnetize the tool joint as established during standardization and apply the magnetic-particle bath by gently spraying or flowing the suspension over the tool joint. Allow at least 3 s for indications to form and then examine the area that is visible using ultraviolet light.

Roll the tool joint and inspect successive areas until 100 % of the tool-joint OD surface has been inspected.

10.25.7.2.4 Magnetizing rod

Magnetize the pipe. With the tool joint in a darkened area, apply the magnetic-particle bath by gently spraying or flowing the suspension over the tool joint. Allow at least 3 s for indications to form and then examine the area that is visible using ultraviolet light.

Roll the tool joint and inspect successive areas until 100 % of the tool-joint OD surface has been inspected.

10.25.7.3 White background and black magnetic-particle wet method

10.25.7.3.1 General

The steps in 10.25.7.3.2 to 10.25.7.3.4 are conducted in a lighted area (538 lx minimum visible light). Darkened lenses or photochromic lenses shall not be worn. White contrast background materials shall be applied to the entire tool-joint outside diameter excluding hard-banding, in a light, even coat. Care shall be taken not to damage the background coating during handling, until the inspection is complete.

10.25.7.3.2 Yoke

With the tool joint in a lighted area, place the yoke transversely across the tool-joint OD approximately 12,7 mm (0.5 in) from the shoulder. Energize the yoke and, while the current is on, apply the magnetic-particle bath by gently spraying or flowing the suspension over the tool-joint OD in the magnetized area. Allow at least 3 s for indications to form and then examine the area for longitudinal imperfections while still applying the current.

If no indication is found, turn off the yoke and move it, allowing for proper overlap, and repeat the above procedure. Continue to inspect and move until the entire OD surface on tool joints, or a distance of

254 mm (10.0 in) from the shoulder for other down-hole drill stem elements, excluding hard-banding, has been inspected for longitudinal flaws.

Inspect the entire area for transverse imperfections with the legs of the yoke placed longitudinally, following the same procedures as above.

10.25.7.3.3 Coil

With the tool joint in a lighted area, place the coil over the tool-joint OD approximately in the middle of the tool joint. Magnetize the tool joint as established during standardization and apply the magnetic-particle bath by gently spraying or flowing the suspension over the tool joint. Allow at least 3 s for indications to form and then examine the area that is visible.

Roll the tool joint and inspect successive areas until 100 % of the tool-joint OD surface has been inspected.

10.25.7.3.4 Magnetizing rod

Magnetize the pipe. With the tool joint in a lighted area, apply the magnetic-particle bath by gently spraying or flowing the suspension over the tool joint. Allow at least 3 s for indications to form and then examine the area that is visible.

Roll the tool joint and inspect successive areas until 100 % of the tool-joint OD surface has been inspected.

10.25.8 Evaluation and classification

Any heat-check cracking within 51 mm (2 in) of the box sealing shoulder or deeper than 0,5 mm (0.020 in) is non-repairable and shall be cause for rejection. Heat-check cracking equal to or less than 0,5 mm (0.020 in) deep shall be removed or the tool joint shall be rejected.

10.26 Tool joints — Measure the tool-joint counterbore depth, pin-base length and seal width

10.26.1 Description

Values obtained by measurement of the counterbore depth and the pin-base length can provide positive evidence of over-re-facing. A shoulder flatness check can provide evidence of high or low spots on the face that can result in an improper seal. Seal width provides for a contact area on the face that is sufficiently large so the metal at the face does not yield at normal make-up torque.

NOTE Over-re-faced tool joints can have counterbore depths and pin-base lengths within tolerance.

10.26.2 Surface preparation

All surfaces being examined shall be cleaned so that foreign material does not interfere with the detection process.

10.26.3 Equipment

A 250 mm metal rule with 0,5 mm divisions (or a 12 in rule with 1/64 in divisions), bevel protractor and hardened and ground profiles for the thread form being inspected are required. A dial calliper may be substituted for the metal rule. Metal rule and dial calliper shall meet the requirements of 9.2.2 and 9.2.3. An additional straightedge is required if eccentrically worn box shoulders are found.

10.26.4 Illumination

Illumination shall meet the requirements of 9.3.2.

10.26.5 Inspection procedure

Measure the length of the counterbore. Place the rule so that the end is at the intersection of the counterbore and the beginning of the tapered section and record the distance at the plane of the face. The minimum counterbore length is shown in Table C.7 (Table D.7). Boxes with counterbore lengths less than the value in Table C.7 (Table D.7) shall be rejected.

Measure the length of the pin base, L_{pb} (see Figure 9). Using a profile gauge, locate the point of the first full-thread depth nearest the sealing shoulder. Place the rule so that the end is against the face and record the distance at the intersection of the pin base and the thread flank at the point of the first full-depth thread. The maximum pin-base length is shown in Table C.7 (Table D.7); pins with longer bases shall be rejected.

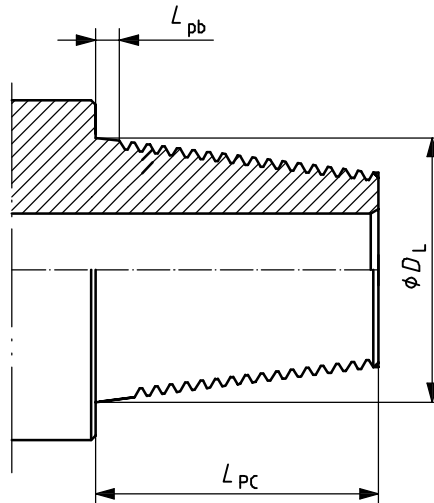

Figure 9 — Pin measurement areas

Seal width is measured from the corner of the outside bevel and sealing face to the corner of the inside bevel and face. Measurements shall be taken at the point that the seal appears to be the thinnest (see Figure 2). Seal widths shall not be less than 1,2 mm (0.047 in) smaller than the minimum shoulder width specified in Table C.6 (Table D.6).

Place a straight edge along the 18° shoulder of the box tool joint at three places around the diameter. Observe any gaps between the straight edge and the 18° shoulder; record minimum contact. Use a bevel protractor to measure the angle of the 18° shoulder, report shoulder angles not meeting the owner/user requirements. In the absence of owner/user requirements, report all tool joints with shoulder angles not between 16° and 20°.

10.27 BHA connection — Visual inspection of bevels, seals, threads and stress-relief features

10.27.1 Description

This inspection covers the visual examination of the BHA connections. The inspection can be broken down into four main areas: bevel, sealing shoulder, threads and stress-relief features, if present.

This inspection is done in a lighted area (538 lx minimum visible light) and includes the following.

- a) Verify the presence of a bevel around the complete circumference.
- b) Inspect the seal to detect high spots caused by mechanical impact and surface damage, such as gouges, cuts, pits, dents and other visually detectable imperfections that can affect the sealing of the connection. Shoulder flatness is also checked.

- c) The threads shall provide an interference-free make-up surface on a rotary shouldered connection. As an aid in detecting thread-form irregularities, a profile gauge shall be used on each connection.
- d) Stress-relief features provide a smooth area to spread cyclic stresses. Their ability to do this depends on their surface being smooth and free of stress concentrators. Inspection is done to locate and evaluate stress concentrators in the features.

10.27.2 Preparation

All surfaces being examined shall be cleaned so that foreign material does not interfere with the detection process. Items for inspection shall be placed such that they can be rolled 360° during the inspection.

10.27.3 Equipment

A metal rule with 0,5 mm divisions or 1/64 in divisions, a hardened and ground profile gauge, an inspection mirror, a lead gauge with proper setting standard and contacts, and a portable light or mirror for illumination of internal boreback surfaces are required.

10.27.4 Calibration

Lead gauges shall be calibrated at least every six months and after being subjected to unusual shock that can affect the accuracy of the gauge.

10.27.5 Illumination

Illumination shall meet the requirements of 9.3.2.

10.27.6 Standardization

Lead gauge contacts shall be the prescribed diameter [$\pm 0,05$ mm (± 0.002 in)] [see Table C.3 (Table D.3)] and set in the lead gauge at a 51 mm (2 in) interval. The lead gauge shall be standardized on the setting standard so that the null point is at zero when the gauge is oscillated through a small arc.

10.27.7 Inspection procedure

Verify the presence of a bevel around the full circumference. At least a 0,79 mm (1/32 in) bevel shall be present for the full circumference. Any evidence of strap-welding shall cause the component to be rejected.

The shoulder face provides the only seal on a rotary shouldered connection. To accomplish this task, the face shall be smooth and flat. Examine the sealing shoulder using visual-inspection techniques. Use a finger tip and/or straightedge to supplement the visual inspection in the detection of large-area depressions and bulges. Either of these conditions requires re-facing or shop repair. Localized imperfections on the sealing shoulders, such as pits, cuts, gouges and grooves, shall be evaluated in accordance with 10.27.8.1.

Visually check the box shoulder for eccentricity. If the connection is eccentric, determine whether the bore is in the centre of the connection. If the thread axis and bore axis are off-centre by more than 1,5 mm (0.06 in), the tool shall be marked for disposition by the owner/user, since down-hole tools can get caught in the off-centring.

Use a straightedge across the box face and across a chord of the pin face to check for shoulder flatness. Any visual indication that the shoulder is not smooth and flat shall be cause for rejection.

Thread-root surfaces shall not have sharp-bottomed depressions extending beyond the root cone of the thread or round-bottomed, corrosion-like depressions exceeding 0,79 mm (0.031 in) below the root cone of the thread. These conditions require shop repair.

The thread surfaces shall be inspected for any protrusions of metal above the surface. Dents and mashes are typical causes of protrusions. Thread surfaces shall also be inspected for cuts, pits and gouges. A thread-profile gauge shall be used to inspect the condition of the thread profile of both the pin and box for wear. The

inspector shall look for visible light between the gauge and the thread flanks, roots and crest and rocking of the profile gauge. Two thread-profile checks, 90° apart, shall be made on each connection. Visible light or rocking of the profile gauge requires examination with a lead gauge to determine if the threads are stretched.

Place a straightedge in the box on the crest of the threads to determine whether the thread crests are on a consistent taper. Any rocking of the straight edge is cause for rejection.

10.27.8 Evaluation and classification

10.27.8.1 Sealing shoulders

All faces with high spots shall be rejected.

All sealing shoulders that show evidence of galling shall be rejected.

The sealing shoulders shall be inspected for any depression in the surface that can cause the connection to leak. Depressions that do not lie closer than 1,5 mm (0.06 in) to the OD bevel or the counterbore bevel are acceptable. Depressions that do not cover more than 50 % of the radial width of the seal surface or extend more than 6,4 mm (0.25 in) in the circumferential direction are acceptable. All other depressions shall be rejected.

10.27.8.2 Re-facing of rejected sealing faces

Faces that have been rejected for areas of fluid erosion, leaks, galls, fins or metal with high spots above the sealing surface may be field re-faced to repair the defect responsible for their rejection, provided that

- a) the maximum removal of material does not exceed 0,79 mm (0.031 in) from a pin or box during any one re-facing, and
- b) not more than 1,57 mm (0.062 in) of material is removed cumulatively. At each re-facing, a minimum amount of material shall be removed. If benchmarks or other evidence indicates more than these limits have been removed, the connection shall be rejected.

NOTE Without benchmarks, the amount of cumulative re-facing cannot be determined with certainty.

After repair, the face shall be re-examined for compliance with the criteria of 10.27.7.

10.27.8.3 Thread surfaces

10.27.8.3.1 Protrusions

All threads with protrusions shall be rejected. Surfaces rejected for protrusions may be repaired by filing with a hand file. The thread profile shall be checked after any such filing and the requirements of 10.27.8.3.4 shall be met or the connection shall be rejected.

10.27.8.3.2 Galling

All galled threads shall be rejected.

10.27.8.3.3 Pits, cuts and gouges

Pits, cuts and gouges that result in slight depressions in the flanks and crests of the threads are acceptable as long as they do not extend more than 38 mm (1.5 in) in length. Sharp-bottomed imperfections in the thread roots shall be cause for rejection. Pits, cuts and round-bottomed gouges that are in the root of the thread shall be cause for rejection if they are within two threads of the last engaged thread. Pits, cuts and round-bottomed gouges that are in the root of other threads shall not exceed 0,79 mm (0.031 in) in depth.

10.27.8.3.4 Thread profile

A thread profile gauge shall be used to inspect the condition of the thread profile of both the pin and box for wear. The inspector shall look for visible light between the gauge and the thread flanks, roots and crest. If the visible gap between the gauge and the thread crest is more than 0,79 mm (0.031 in) over four consecutive threads or 1,5 mm (0.06 in) over two consecutive threads, the connection shall be rejected. Visible gaps between the gauge and the thread flanks estimated to be more than 0,4 mm (0.016 in) shall be cause for rejection. Any indication of stretching shall be further inspected for stretching according to 10.15.6.2.

10.27.8.4 Stress-relief features

The cylindrical section of the stress-relief groove and boreback shall be free of round-bottomed corrosion, pits, cuts, tool marks or other stress raiser deeper than 0,79 mm (0.031 in), and sharp-bottomed imperfections deeper than 1,5 mm (0.06 in). It is permissible to remove small areas of corrosion by polishing the area with emery cloth or a flapper wheel. A relief groove containing cold-steel die stamp marks shall be rejected.

10.27.9 Repair of rejected bottom-hole-assembly connections

Shop repair and return to service is normally available for rejected bottom-hole-assembly connections if the other requirements, such as length and tong space, are met. Areas containing cracks shall be cut off prior to repair. All recut connections shall meet the requirements for new connections and shall be inspected in accordance with 10.31 for ferromagnetic BHA component recuts and 10.32 for non-ferromagnetic BHA component recuts.

10.28 BHA — Measure box outside diameter, pin inside diameter, counterbore diameter and benchmark location if a benchmark is present

10.28.1 Description

The outside diameter of the boxes and inside diameter of the pins are measured. The values are recorded so that the bending-strength ratio can be calculated when a mating piece is determined. For drill-collar strings, measure the inside diameters of all collars in the string and determine the minimum outside diameter that meets the minimum bending-strength ratio based on the smallest inside diameter. Determine the maximum outside diameter that meets the maximum bending-strength ratio based on the largest inside diameter. Drill collars between the minimum and maximum diameter meet the prescribed bending-strength ratio regardless of the order in which they are assembled. Drill collars outside the acceptable outside-diameter range are marked for disposition by the owner/user. Counterbore diameters are measured to determine if box swell has occurred. If benchmarks are present, the location in relation to the sealing face is measured.

10.28.2 Surface preparation

All surfaces being measured shall be cleaned so that foreign material does not interfere with the measurement process.

10.28.3 Equipment

A 250 mm metal rule with 0,5 mm divisions (or a 12 in rule with 1/64 in divisions) and outside-diameter and inside-diameter callipers are required. A dial calliper may be substituted for the metal rule. Metal rule and dial calliper shall meet the requirements of 9.2.2 and 9.2.3.

10.28.4 Illumination

Illumination shall meet the requirements of 9.3.2.

10.28.5 Inspection procedure

Examine the connection outside diameter for the minimum diameter approximately 102 mm (4.0 in) from the sealing shoulder using the callipers to measure the OD of the box. When the minimum outside diameter is found, adjust the callipers until they are sized to the minimum diameter.

Using the metal rule or callipers, measure the distance between the contacts on the calliper.

Record the minimum outside diameter.

Adjust the inside-diameter callipers until they are sized to the inside diameter of the pin approximately 76 mm (3.0 in) from the end of the pin.

Using the metal rule or callipers, measure the distance between the contacts on the callipers.

Record the maximum inside diameter.

Using a precision rule or dial calliper, measure the counterbore diameter, Q_C , or low-torque counterbore, $D_{L\text{Torq}}$ (Figures 10 and 11) at two places approximately 90° apart. The measurement is made from the projected intersection of the counterbore with the box face rather than to the internal bevel. Diameters shall not exceed the values listed in Tables C.9 and C.10 (Tables D.9 and D.10).

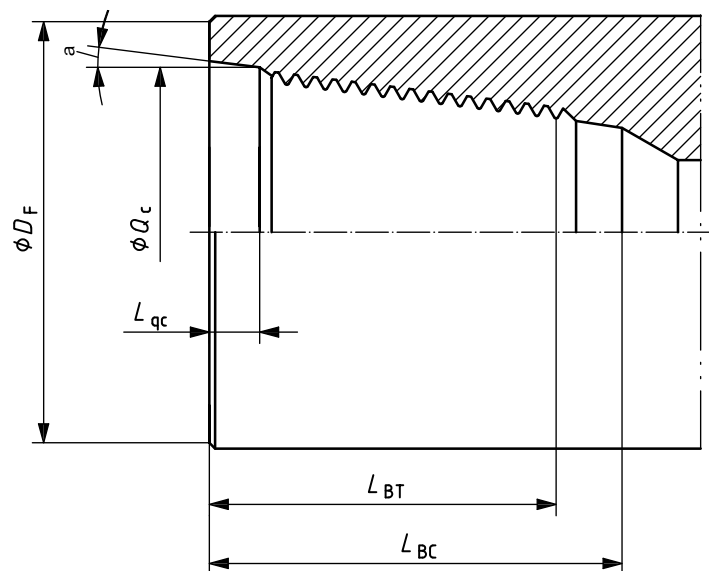

a Taper.

Figure 10 — Box measurement areas

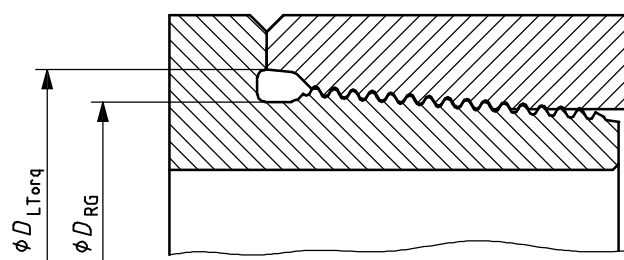

Figure 11 — Low-torque connection

If benchmarks are present, measure the distance from the benchmark to the face. If the distance indicates that more than 1,5 mm (0.06 in) has been removed by re-facing, the connection shall be rejected. Recording the value is not required.

10.28.6 Evaluation and classification

10.28.6.1 Bending-strength ratios

If the bending-strength ratio ranges are being evaluated, the acceptable range shall be provided by the owner/operator. Without guidelines, the agency records the outside and inside diameters without evaluation.

When an acceptable bending-strength range is provided, determine the smallest and largest inside diameter for the string. Use the smallest inside diameter to determine the smallest outside diameter measurement within the string that meets the bending-strength ratio range. Use the largest inside diameter to determine the largest outside diameter measurement that meets the bending strength ratio range. These two values become the range of acceptable outside diameters for the bottom-hole assembly.

For standard connections, Table C.12 (Table D.12) provides outside diameters and inside diameters corresponding to bending-strength-ratio ranges for a wide variety of rotary shouldered connections. Minor differences between measured inside diameter and inside diameters in Table C.12 (Table D.12) are of little significance; therefore, select the inside diameter closest to the measured diameter.

The following BSR ranges may be used as guidelines in specifying acceptable BSRs:

- a) BHA smaller than 152 mm (6 in): 1,90 to 2,50;
- b) BHA 152 mm to 203 mm (6 in to 8 in): 2,25 to 2,75;
- c) BHA larger than 203 mm (8 in): 2,50 to 3,20.

For proprietary connections, consult the manufacturer's guidelines for determining bending-strength ratios.

10.28.6.2 Counterbore diameter

If the counterbore diameter exceeds the maximum diameter value in Table C.9 or Table C.10 (Table D.9 or Table D.10), the box shall be rejected.

10.29 BHA — Check bevel diameter

10.29.1 Description

The bevel diameter affects the force with which the sealing shoulders are engaged at a given make-up torque. This affects the ability of the shoulders to stay together and remain sealed in a bending moment down-hole.

10.29.2 Surface preparation

All surfaces being checked shall be cleaned so that foreign material does not interfere with the measurement process.

10.29.3 Equipment

A 250 mm metal rule with 0,5 mm divisions (or a 12 in rule with 1/64 in divisions) and OD callipers are required if the check is going to be made with callipers. A dial calliper may be substituted for the metal rule. If the check is going to be made with dial callipers only, a dial calliper is required. The metal rule and dial calliper shall meet the requirements of 9.2.2 and 9.2.3.

10.29.4 Illumination

Illumination shall meet the requirements of 9.3.2.

10.29.5 Inspection procedure

Set the calliper to the maximum bevel diameter listed for the appropriate BHA component and outside diameter [see Table C.11 (Table D.11)].

Check each bevel diameter to verify that the diameter is smaller than the maximum. This check shall be done in two places on each connection approximately 90° apart.

Set the calliper to the minimum outside diameter listed for the appropriate BHA component and outside diameter.

Check each bevel diameter to verify that the diameter is larger than the minimum. This check shall be done in two places on each connection approximately 90° apart.

10.29.6 Evaluation and classification

Bevel diameters that do not fall within the specified range shall be measured (see 10.30).

10.30 BHA — Measure bevel diameter

10.30.1 Description

The bevel diameter affects the bearing stress with which the sealing shoulders are engaged at a given make-up torque. This affects the ability of the shoulders to stay together and remain sealed in a bending moment down-hole.

10.30.2 Surface preparation

All surfaces being measured shall be cleaned so that foreign material does not interfere with the measurement process.

10.30.3 Equipment

A 250 mm metal rule with 0,5 mm divisions (or a 12 in rule with 1/64 in divisions) and OD callipers are required if measurement is going to be made with callipers. A dial calliper may be substituted for the metal rule. If the measurement is going to be made with dial callipers only, a dial calliper is required. The metal rule and dial calliper shall meet the requirements of 9.2.2 and 9.2.3.

10.30.4 Illumination

Illumination shall meet the requirements of 9.3.2.

10.30.5 Inspection procedure

Set the calliper to the intersection of the bevel and sealing shoulder of the connection.

Use the metal rule or dial calliper to determine the diameter.

10.30.6 Evaluation and classification

Bevel diameter shall be within the ranges specified in Table C.11 (Table D.11). Bevel diameters outside the allowed range shall be re-bevelled or the BHA component shall be rejected.

10.31 BHA — Magnetic-particle inspection of the pin and box threads

10.31.1 General

In 10.31 the equipment requirements, descriptions and procedures are provided for wet fluorescent-magnetic-particle inspection of the external surface of the pin-thread area and the internal surface of the box threads on used bottom-hole-assembly connections. Inspection includes stress-relief features if present. This inspection is performed to detect transverse cracks in the thread roots and stress-relief features with special attention to the last engaged thread.

The pin-thread area is from the small end of the pin up to and including the intersection of the pin base or stress-relief groove and the sealing shoulder. The box threaded area is from the large end of the counterbore to the end of the thread root in the small end of the box or the end of the small-end boreback taper in a boreback box.

10.31.2 Equipment

10.31.2.1 Coil

A DC (HWAC, FWAC or filtered FWAC or pulsating DC) coil shall be used for this inspection. The number of turns of the coil shall be clearly marked on the coil.

10.31.2.2 Fluorescent inspection

Fluorescent-magnetic-particle solutions shall comply with the requirements of 9.4.8.3. An ultraviolet light source, fluorescent magnetic particles, a 100 ml centrifuge tube (with 0,05 ml increments) and an ultraviolet light meter are required. If the magnetic particles are supplied as an aerosol, the centrifuge tube is not required.

10.31.2.3 Additional equipment

Additional equipment includes a magnetometer (or gauss meter).

10.31.3 Illumination

Illumination of the surfaces for fluorescent-magnetic-particle inspection shall comply with the requirements of 9.4.8.5.

10.31.4 Surface preparation

The inspection areas shall be cleaned of all grease, thread compound, dirt and any other foreign matter that can interfere with particle mobility, complete wetting of the surface by the particle carrier and indication detection.

Surface coatings, such as anti-gall treatment, shall be smooth and shall have a thickness equal to or less than 0,05 mm (0.002 in).

10.31.5 Calibration

Equipment calibration is covered in Clause 9.

10.31.6 Standardization

10.31.6.1 DC coil on pin connection

Select a typical bottom-hole-assembly connection from the string for inspection. Place the coil on the bottom-hole-assembly connection near the sealing shoulder. For drill collars, the polarity of the coil shall be the same as the residual polarity in the drill collar. Energize the coil to establish a residual longitudinal field. Using the residual field, apply magnetic particles to the inspection area and observe the particle mobility. If the magnetic particles continue to flow for longer than 10 s, increase the magnetic field strength and reapply magnetic particles. If the magnetic particles are pulled out of suspension prematurely, i.e. within an interval shorter than 6 s, reverse the coil and apply slightly less current. Continue until the magnetic particle mobility is from 6 s to 10 s after application.

NOTE Short subs and other components might not retain sufficient field to inspect using a residual field. If the maximum available magnetizing force is used and the proper particle mobility cannot be achieved, it is necessary to establish an active magnetic field to the same criteria as above.

After the proper magnetic field has been established based on particle mobility, measure the field at the end of the connection using a gauss meter or magnetometer. For multiple components of the same description, the field in each subsequent connection shall be within 10 % of the established field strength.

10.31.6.2 DC coil on box connection

Select a typical tool joint from the string for inspection. Place the DC coil over the tool joint near the threaded area. Energize the coil as specified in Table C.1 (Table D.1) based on the outside diameter of the box connection. Using the residual field, apply magnetic particles to the thread area and observe the particle mobility. Adjust the field as high as possible without the magnetic particles being prematurely pulled out of suspension in the threaded area. Particle mobility should continue for at least 6 s.

After the proper magnetic field has been established based on particle mobility, measure the field at the end of the connection using a gauss meter or magnetometer. For multiple components of the same description, the field in each subsequent connection shall be within 10 % of the established field strength.

10.31.7 Inspection procedures

10.31.7.1 General

The steps for inspection found in 10.31.7 are the minimum requirements and can vary depending on the connection condition and the options agreed to between the owner and the agency. Visible-light inspection of the threads in accordance with 10.27 is required prior to the ultraviolet-light inspection.

The following steps are to be conducted in a darkened area (21,5 lx maximum visible light). The inspector shall be in the darkened area at least 1 min prior to beginning inspection to allow eyes to adapt. Darkened lenses or photochromic lenses shall not be worn.

10.31.7.2 Pin-thread inspection

Place the coil on the pin shoulder to be inspected.

Energize the coil with the magnetizing current at the level established during standardization for at least 1 s. Turn the coil off. Move the coil out of the way and measure the field at the end of the bottom-hole-assembly connection, as specified by the criteria established in 10.31.6.1. Adjust the coil as necessary to establish the proper field.

Apply the magnetic-particle bath by gently spraying or flowing the suspension over the threads. Examine the threaded area completely around the pipe, paying particular attention to the root of the last engaged thread. Reapplication of particles is required when the section that was on the bottom is rolled to the top.

10.31.7.3 Box thread inspection

For the box, place the coil over the bottom-hole-assembly connection centred over the threaded area.

Energize the coil with the magnetizing current at the level established during standardization for at least 1 s. Turn the coil off. Measure the field at the end of bottom-hole-assembly connection as specified in the criteria established in 10.31.6.2. Adjust the coil as necessary to establish the proper field.

Apply the magnetic-particle bath by gently spraying or flowing the suspension over the threads. Examine the threaded area on the top half of the connection, using a mirror to examine the thread roots, paying particular attention to the root of the last engaged thread. Rotate the bottom-hole-assembly connection 180° and apply the particles. Examine the threaded area on the top half of connection, using a mirror to examine the thread roots, paying particular attention to the root of the last engaged thread.

Magnetic particles and cleaning materials shall be removed after inspection.

10.31.8 Evaluation

Evaluate all crack-like indications to verify that they are cracks.

10.31.9 Classification

BHA containing cracks shall be rejected and considered unfit for further drilling service.

10.32 BHA connection — Liquid-penetrant inspection of the pin and box threads

10.32.1 General

In 10.32 the equipment requirements, descriptions and procedures are provided for visible-dye liquid-penetrant inspection of the external surface of the pin-thread area and the internal surface of box threads on used, non-ferromagnetic bottom-hole-assembly connections. This inspection is performed to detect cracks in the threaded area with special attention to the last engaged thread roots.

The pin-thread area is from the small end of the pin up to and including the intersection of the pin base or stress-relief groove and the sealing shoulder. The box threaded area is from the small end of the counterbore to the end of the thread root at the small end of the box or the end boreback taper in a boreback box.

10.32.2 Equipment

The following equipment is required:

- a) penetrant, which may be either solvent-removable or water-washable;
- b) penetrant cleaner/remover, liquid-penetrant and penetrant developer, from the same manufacturer and compatible with each other;
- c) inspection mirror (required for the box connections);
- d) lint-free clean cloths;
- e) mirror or portable light for illumination of internal surfaces.

10.32.3 Illumination

Illumination of the inspection surfaces shall comply with the requirements of 9.3.2.

10.32.4 Surface preparation

The inspection areas shall be cleaned of all grease, thread compound, dirt and any other foreign matter that can interfere with the penetrant capillary process. The cleaning may be accomplished by steam cleaning, mineral spirits or a commercial penetrant cleaner. If cleaned with anything other than a commercial penetrant cleaner, a final cleaning shall be done with commercial penetrant cleaner to remove any cleaning product residue.

10.32.5 Calibration

None is required.

10.32.6 Standardization

For penetrant inspection, the temperature of the connection shall be within the penetrant manufacturer's specified limits throughout the inspection process.

If a penetrant recycling system is used, the inspection agency shall have a documented performance check to compare performance against new penetrant. This requirement is not applicable to one-time-use methods.

10.32.7 Inspection procedures

Conduct a visual inspection of all the surfaces being evaluated for any visible indications of cracks. Any area having indications that may be cracks shall be inspected with a localized penetrant inspection prior to the inspection of the entire threaded area. If cracks are confirmed within those areas, the connection shall be rejected. Additional inspections are required only if there is a requirement to determine the extent of the area being cut off.

If no cracks are detected visually or with the localized penetrant examination, apply penetrant to the entire area being inspected with penetrant by any suitable means. Penetrant shall not be allowed to dry during the dwell process. Dwell time shall be based on the penetrant manufacturer's recommendation.

Remove excess solvent-removable penetrant by wiping with clean, lint-free cloths until virtually all penetrant has been removed. The last traces of the penetrant shall be removed with a clean, lint-free cloth lightly moistened with cleaner/solvent remover. For the box connection, a mirror is required to check the cleaning of the box threads.

Remove water-washable penetrant by washing, which shall be done with a coarse spray at a pressure not exceeding 280 kPA (40 psi). Avoid over-rinsing. For the box connection, a mirror is required to check the cleaning of the box threads.

Solvent shall not be sprayed or otherwise applied directly to the surfaces being inspected. Inspection sensitivity is affected by the number of wipes it takes to clean the excess penetrant from the surface.

Apply the developer within 5 min of the excess-penetrant removal. Developer shall be applied in such a manner that there is a light coating of developer in the thread roots and stress-relief features. Development time starts when the developer has dried. Developer dwell time shall be based on the penetrant manufacturer's recommendation.

Initial examination of all surfaces being inspected shall be conducted within 1 min of the application of the developer. After the required dwell time but not more than 1 h after the developer has dried, conduct the final inspection.

After inspection, all penetrant and developer shall be removed.

10.32.8 Evaluation

Evaluate all crack-like indications to verify that they are cracks.

10.32.9 Classification

BHAs containing cracks shall be rejected and considered unfit for further drilling service.

10.33 BHA — Dimensional measurement of stress-relief features

10.33.1 Description

In 10.33 procedures are provided for the dimensional measurement of stress-relief groove and boreback features. The dimensions of the boreback in the box and stress-relief groove on the pin are not affected by usage. If there have been previous dimensional inspections of the stress-relief features, rechecking each time the connection is inspected is normally not necessary.

10.33.2 Surface preparation

All surfaces being examined shall be cleaned so that foreign material does not interfere with the detection process.

10.33.3 Equipment

The following equipment is required:

- a) mirror or spotlight, for internal illumination;
- b) 250 mm metal rule with 0,5 mm divisions (or a 12 in rule with 1/64 in divisions);
- c) precision callipers capable of reaching the diameter of the stress-relief groove;
- d) telescope gauge or inside micrometer suitable for the diameter of the boreback.

NOTE A dial calliper can be substituted for the metal rule.

Metal rule, micrometers and dial callipers shall meet the requirements of 9.2.2 and 9.2.3.

10.33.4 Illumination

Illumination shall meet the requirements of 9.3.2.

10.33.5 Inspection procedure

Roll the bottom-hole assembly to find the point that the stress-relief groove intersects the crest of the thread.

Using a rule or dial callipers, measure the length of the stress-relief groove from the shoulder to the point at which the groove intersects the thread crest (see Figure 12). Record the measurement on the inspection work sheet.

Using precision callipers, measure the diameter of the stress-relief groove in the centre of the groove, D_{RG} , (see Figure 12). Record the measurement on the inspection work sheet.

Position the telescope gauge across the diameter of the boreback approximately 12,7 mm (0.5 in) in back of the last thread scratch in the boreback (see Figure 13). Verify that the telescope gauge is across the diameter and normal to the thread axis. Lock the telescope gauge using the locking screw. Remove the telescope gauge and measure the size using a digital/dial calliper. Record the measurement on the inspection work sheet.

Locate the last thread scratch in the box connection. Measure the distance from the shoulder face to the last scratch (see Figure 13, L_X). Record the measurement on the inspection work sheet.

Measure the distance, L_{CYL} , to the end of the cylindrical section of the boreback (see Figure 13).

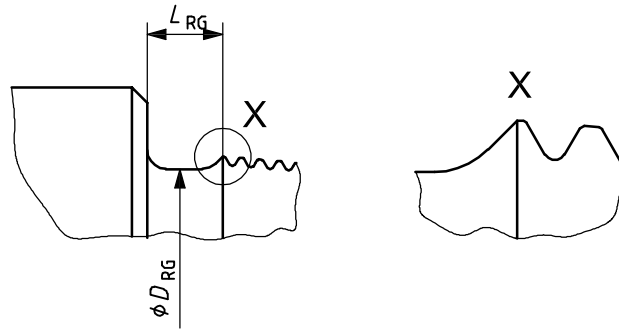

Figure 12 — Stress-relief groove

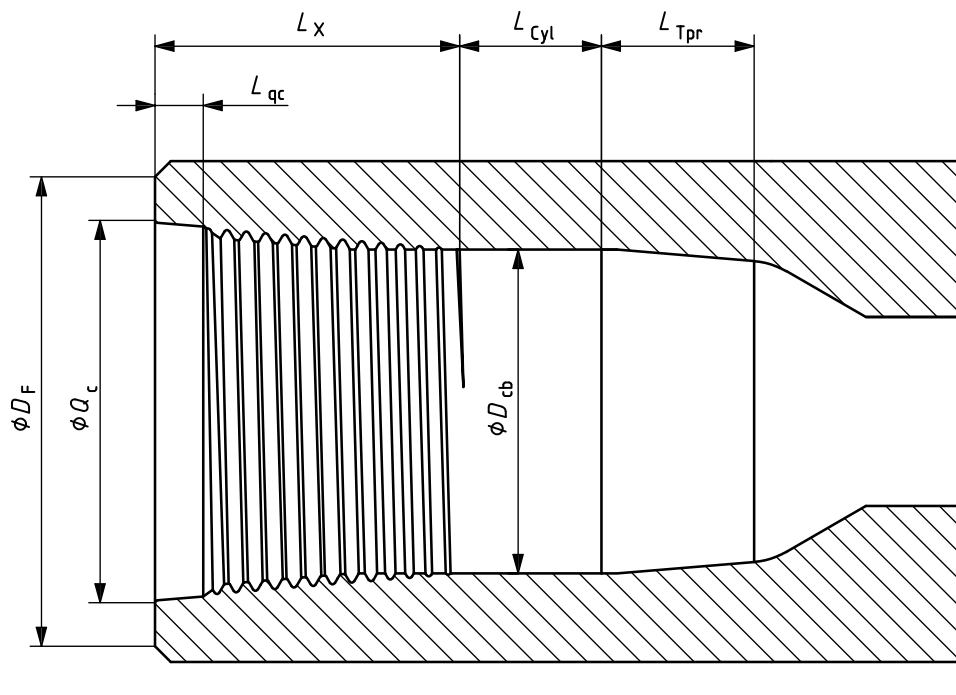

Figure 13 — Boreback box

Key

- 1 profile gauge
- 2 full-depth thread
- 3 non-full-depth thread

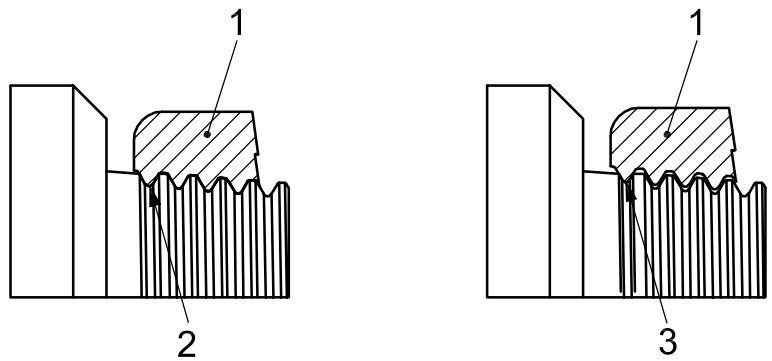

Figure 14 — Location of last full-depth thread

10.33.6 Evaluation and classification

The length of the stress-relief groove, L_{RG} , shall not be less than 24,6 mm (0.97 in) nor more than 26,2 mm (1.03 in). An alternate stress-relief groove length of 19,0 mm (0.75 in) to 31,7 mm (1.25 in) may be used by agreement on rental tools and other short-term usage tools.

The diameter of the stress-relief groove, D_{RG} , shall not be less than the minimum or greater than the maximum value shown in Table C.10 (Table D.10).

The boreback length, L_X , from the shoulder to the last scratch of the thread shall meet the requirements of Table C.10 (Table D.10) or the connection shall be rejected.

The length, L_{Cyl} , of the boreback cylinder shall not be less than 25 mm (1 in) or the connection shall be rejected.

The boreback cylinder diameter, D_{cb} , shall not be greater than maximum value or less than the minimum value shown in Table C.10 (Table D.10).

10.34 Length measurements of the counterbore, pin and pin neck

10.34.1 Description

The dimensions of counterbore length, pin length and pin neck length (on non-stress-relieved connections) measurements are inconclusive as to the amount of re-facing that has been done but can indicate that the connection has been re-faced beyond the 1,5 mm (0.06 in) cumulative re-facing limit. Re-facing is the only thing that affects these lengths in use. If the counterbore length is at the specified minimum of 16 mm (0.63 in) when new and the length is less than 14,2 mm (0.56 in) on subsequent inspection, the connection has been re-faced beyond limits. If the counterbore had been longer than the minimum when new, the re-facing limits would be reached prior to reaching 14,2 mm (0.56 in), thus the measurements are inconclusive regarding re-facing. Benchmarking is the only reliable way to evaluate the amount of re-facing.

10.34.2 Surface preparation

All surfaces being examined shall be cleaned, so that foreign material does not interfere with the detection process.

10.34.3 Equipment

The following equipment is required:

- a) 250 mm metal rule with 0,5 mm divisions (or a 12 in rule with 1/64 in divisions);

NOTE A dial calliper can be substituted for the metal rule.

- b) hardened and ground profile gauge;
- c) metal rule, micrometers, and dial callipers, which meet the requirements of Clause 9.

10.34.4 Illumination

Illumination shall meet the requirements of 9.3.2.

10.34.5 Inspection procedure

Measure the distance from the face to the intersection of the counterbore and inside-diameter chamfer parallel to the thread axis. The length shall not be less than the value shown in Tables C.9 and C.10 (Tables D.9 and D.10).

Measure the length of the pin from the sealing shoulder to the face of the pin parallel to the thread axis. The pin length shall not be greater than the maximum value or less than the minimum value shown in Tables C.9 and C.10 (Tables D.9 and D.10).

Use a profile gauge to locate the last point of full thread depth near the sealing shoulder on non-stress-relieved pins. This is done by placing the profile gauge in the thread and moving it toward the shoulder until the decreased depth of the last thread root begins to lift the profile gauge (see Figures 14 and 15). Mark that point on the pin base. At that location, measure the distance from the shoulder to the intersection of the pin base and the stab flank nearest the shoulder. If that distance is more than the maximum length as shown in Table C.9 (Table D.9), the connection shall be rejected.

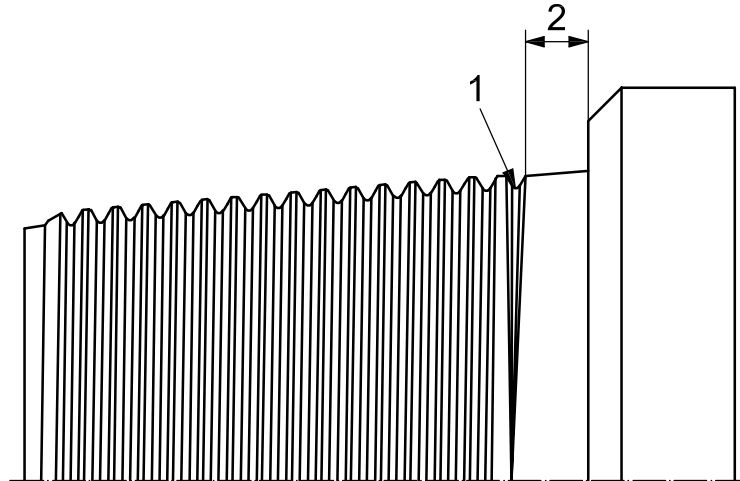

Key

- 1 last full-depth thread
- 2 pin-base length

Figure 15 — Pin-base length

10.34.6 Evaluation and classification

Measurements shall meet the requirements of Tables C.9 and C.10 (Tables D.9 and D.10) or the connection shall be rejected.

10.35 Drill collar — Visual full-length OD and ID, markings, fish-neck length and tong space

10.35.1 Description

The entire drill-collar outside and inside surface is checked for damage and corrosion. Markings are verified and the serial number recorded. If applicable, the tong space, the distance between the sealing shoulder and the hard-banding or section change, shall be measured. Hard-banding, if present, is visually examined.

10.35.2 Surface preparation

All surfaces being examined shall be cleaned so that foreign material does not interfere with the detection process. Collars shall be positioned so they can be rolled one complete revolution.

10.35.3 Equipment

The following equipment is required.

- a) mirror or portable light, to illuminate the inside surface;
- b) tape measure or rule, to measure the overall length and tong space, if applicable;
- c) rule graduated in 0,5 mm (or 1/64 in) increments.

10.35.4 Illumination

Illumination shall meet the requirements of 9.3.2. A mirror or portable light shall be available for internal illumination.

10.35.5 Inspection procedure

Measure and record shoulder-to-shoulder length of the drill collar.

Observe the drill-collar outside-diameter surface for signs of damage including but not limited to pits, cuts, dents, other mechanical damage and cracks. Place a straightedge along the outside diameter to check for signs of box swell. If the area near the bevel causes the straight edge to lift off, the counterbore diameter shall be measured in accordance with 10.28.5 and 10.28.6.

Using a mirror or portable light, illuminate the inside surface and inspect for corrosion and other irregularities from both ends.

Check the marking for correctness and record the drill-collar serial number on the inspection work sheet.

Check the fish-neck length by placing a rule on the upper-connection outside diameter and measuring the distance from the seal face to the location of any section change.

10.35.6 Evaluation and classification

Areas of surface imperfections deeper than 3,18 mm (0.125 in) shall be inspected for cracks using magnetic particles (see 10.13.10.2) on ferromagnetic materials or liquid-penetrant inspection (see 10.32) on non-ferromagnetic materials. Imperfections deeper than 3,15 mm (0.125 in) on the inside diameter under the pin threads or stress-relief groove or on the outside surface over the box threads or boreback shall be cause for rejection. Bottom-hole-assembly drill stem elements containing sharp-bottomed, transverse cuts or gouges in the body deeper than 6,4 mm (0.25 in) should be marked for limited service. Other conditions shall be recorded on the inspection work sheet for continued monitoring.

Areas of internal surface imperfections, such as deep gouges, shall be inspected for cracks using shear-wave ultrasonic techniques. Drill stem elements containing cracks shall be rejected.

Fish-neck length shall not be less than 254 mm (10.0 in).

10.36 Drill-collar elevator groove and slip-recess magnetic-particle inspection

10.36.1 General

In 10.36 the bi-directional fluorescent-magnetic-particle inspections required for drill-collar elevator grooves and slip recess are described.

10.36.2 Equipment

10.36.2.1 Longitudinal field

An AC yoke or a coil, either AC or DC (HWAC, FWAC or filtered FWAC or pulsating DC), may be used for this inspection. The number of turns of the coil shall be clearly marked on the coil.

10.36.2.2 Transverse field

Use an AC yoke with articulated legs for this inspection.

10.36.2.3 Fluorescent-particle inspection

Fluorescent-magnetic-particle solutions shall comply with the requirements of 9.4.8.3. An ultraviolet light source, fluorescent magnetic particles, a 100 ml centrifuge tube (graduated in 0,05 ml increments) and an ultraviolet light meter are required. If the magnetic particles are supplied as an aerosol, the centrifuge tube is not required.

10.36.3 Illumination

Illumination of the inspection surfaces for visual inspection shall comply with the requirements of 9.3.2. Illumination of the surfaces for fluorescent-magnetic-particle inspection shall comply with the requirements of 9.4.8.5.

10.36.4 Surface preparation

The inspection areas shall be cleaned of all grease, thread compound, dirt and any other foreign matter that can interfere with particle mobility, complete wetting of the surface by the particle carrier and indication detection.

Surface coatings (paint, etc.) shall be smooth and shall have a thickness equal to or less than 0,05 mm (0.002 in).

10.36.5 Calibration

Equipment calibration is covered in Clause 9.

10.36.6 Standardization

10.36.6.1 AC yoke

Select a typical drill collar from the string for inspection and adjust the legs of the yoke to maximize contact with the tool-joint surface when positioned for the appropriate inspection direction.

10.36.6.2 DC coils

Select a typical collar for inspection. Place the coil on the collar with the centreline approximately 305 mm (12.0 in) from the elevator shoulder. Energize the coil to establish a residual longitudinal field. Using the residual field, apply magnetic particles to the area 305 mm (12.0 in) on either side of the coil. Observe magnetic-particle mobility near the end of the 305 mm (12.0 in) on either side of the coil. If the magnetic particles continue to flow for longer than 10 s, increase the magnetic field strength and reapply magnetic particles. If the magnetic particles are pulled out of suspension prematurely, i.e. within an interval shorter than 6 s, reverse the coil and apply slightly less current. Continue until the magnetic-particle mobility is from 6 s to 10 s after application.

After the proper magnetic field has been established based on magnetic particle mobility, record the amperage setting, and that shall become the magnetizing amperage for the remaining collars ($\pm 10\%$).

10.36.6.3 AC coils

Select a typical collar from the string for inspection. Place the coil on the elevator recess area, approximately centred. Energize the coil and apply the magnetic particles on both sides of the coil and observe the distance over which the particles have a definitive movement due to the magnetic field [normally 76 mm (3 in) to 102 mm (4 in)]. This distance becomes the inspection distance for each placement of the AC coil.

10.36.7 Inspection procedures

10.36.7.1 General

The inspection area shall be evaluated with both a longitudinal and transverse/circular magnetic field. The steps for inspection found in 10.36.7 are the minimum requirements and can vary depending upon the drill-collar condition and the options agreed to between the owner and the agency. The yoke shall be used to inspect for longitudinal indications. The coil (DC or AC) or the yoke shall be used to inspect for transverse indications.

The steps in 10.36.7.2 to 10.36.7.3 are conducted in a darkened area (21,5 lx maximum visible light). The inspector shall be in the darkened area at least 1 min prior to beginning inspection to allow the eyes to adapt. Darkened lenses or photochromic lenses shall not be worn.

10.36.7.2 Yoke

When using a yoke to perform this inspection, apply the following procedure.

- a) With the elevator and slip recess in a darkened area, place the yoke transversely across the groove/recess OD approximately 12,7 mm (0.5 in) from the shoulder. Energize the yoke and, while the current is on, apply the magnetic-particle bath by gently spraying or flowing the suspension over the groove/recess surface in the magnetized area. Allow at least 3 s for indications to form and then examine the area while still applying the current and using ultraviolet light. Pay particular attention to the corner of the elevator shoulder and the elevator groove surface.
- b) If no indication is found, turn off the yoke and move it, allowing for proper overlap, and repeat step 10.36.7.2 a). Continue to inspect and move until the entire OD surface of both the elevator groove and slip recess have been inspected for longitudinal indications.
- c) Inspect the entire area with the legs of the yoke placed longitudinally following the same procedures as above. The leg of the yoke shall be placed on the non-recessed surface at each end of the elevator groove and slip recess. Apply the magnetic-particle bath by gently spraying or flowing the suspension over the area between the legs of the yoke. Allow at least 3 s for indications to form and then examine the area using ultraviolet light. Continue to inspect and move until the entire area of the slip and elevator groove has been inspected for transverse indications. Pay particular attention to the corner of the elevator shoulder and the elevator groove surface.

10.36.7.3 Coil

When using a coil to perform this inspection, apply the following procedure.

- a) With the elevator groove and slip recess in a darkened area, place the coil over the collar OD, approximately in the middle of the elevator groove. Magnetize the collar as established during standardization. Apply the magnetic-particle bath by gently spraying or flowing the suspension over the elevator groove. Allow at least 3 s for indications to form and then examine the area using ultraviolet light.
- b) Roll the collar and inspect successive areas until 100 % of the elevator groove and slip recess OD surface has been inspected. Pay particular attention to the corner of the elevator shoulder and the elevator groove surface.

10.36.8 Evaluation and classification

Any cracking shall be cause to reject the component. Cracks shall not be removed.

10.37 Drill-collar elevator-groove and slip-recess measurement

10.37.1 Description

Drill collars with these handling grooves can save time in tripping but they also introduce some potential dangers to rig-floor operations. A strict inspection programme minimizes these dangers. In 10.37 the inspections required for drill-collar elevator grooves and slip recess are described.

10.37.2 Surface preparation

All surfaces being examined shall be cleaned so that foreign material does not interfere with the detection process. Collars shall be positioned so they can be rolled one complete revolution.

10.37.3 Equipment

A 250 mm metal rule with 0,5 mm divisions (or a 12 in rule with 1/64 in divisions), OD callipers and radius gauges to determine 3,18 mm (0.125 in) maximum radius and 25 mm (1.0 in) minimum radius. The metal rule shall meet the requirements of 9.2.3.

10.37.4 Illumination

Illumination shall meet the requirements of 9.3.2.

10.37.5 Inspection procedures

Measure the outside diameter of the drill collar approximately 25 mm (1.0 in) from the elevator shoulder. Record that value on the inspection work sheet. The minimum diameter is the specified outside diameter minus 1,5 mm (0.06 in).

Check the length, L_{eg} , of the elevator groove from the shoulder to the end of the flat section. The length shall not be less than 406 mm (16.0 in).

Check the length, L_{sg} , of the slip recess from the intersection of the outside diameter and the beginning of the top groove radius to the end of the flat section. The length shall not be less than 457 mm (18.0 in) (see Figure 16).

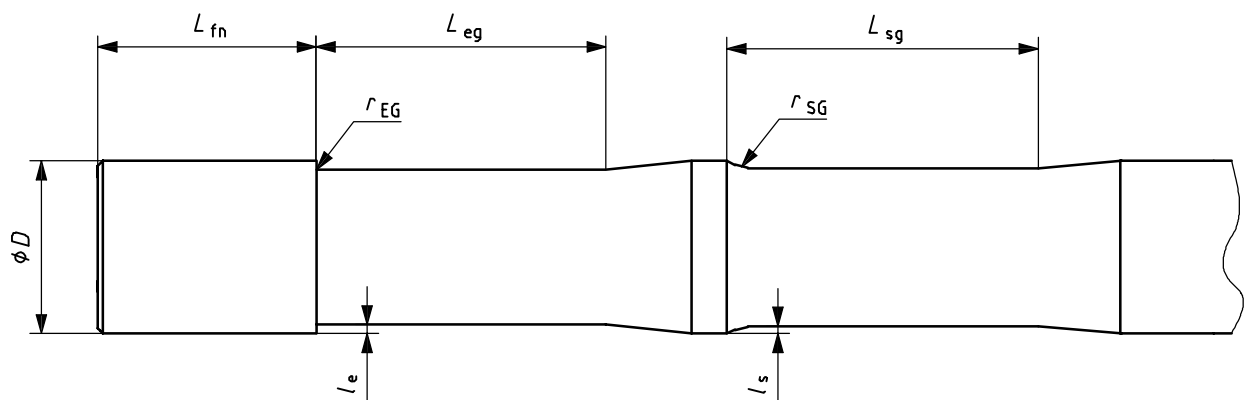

Figure 16 — Elevator and slip groove

Measure the depth of the elevator groove and the slip recess using a straightedge to extend the outside diameter and measure the distance from the straightedge to the flat section of the groove. Measure where the shoulder appears the thinnest. Depths shall be within the ranges shown in Table C.13 (Table D.13).

Using the radius gauge, check the outside corner of the elevator shoulder. The radius shall not exceed 3,18 mm (0.125 in).

Using the radius gauge, check the inside radius at the top of the slip groove. The radius shall be less than 25 mm (1.0 in).

Check the elevator shoulder for flatness. The taper shall not exceed 5°.

If the inspections covered by 10.36 are not performed, inspect the corners of each recess area with magnetic particles in accordance with 10.7, or with liquid penetrant in accordance with 10.32, paying particular attention to the corner at the elevator shoulder.

10.37.6 Evaluation and classification

Drill collars containing cracks shall be rejected. Drill collars that do not meet the dimensional requirements in Table C.13 (Table D.13) shall be classified as limited to use with lift subs only.

10.38 Subs (full-length visual OD and ID), fish-neck length, section-change radius and markings

10.38.1 Description

Check the entire sub outside and inside surface for damage and corrosion. Verify markings and record serial number.

10.38.2 Surface preparation

All surfaces being examined shall be cleaned so that foreign material does not interfere with the detection process. Subs shall be positioned so they can be rolled one complete revolution.

10.38.3 Equipment

The following equipment is required:

- a) mirror or portable light, to illuminate the inside surface;
- b) tape measure or rule, to measure overall length and length of bottleneck section, if present;
- c) radius gauges, 38 mm (1.5 in) and 51 mm (2 in), required for the inspection of bottleneck subs.

10.38.4 Illumination

Illumination shall meet the requirements of 9.3.2. A mirror or portable light shall be available for internal illumination.

10.38.5 Inspection procedure

Observe the sub outside-diameter surface for signs of damage, including but not limited to pits, cuts, dents, other mechanical damage and cracks. Place a straightedge along the outside diameter to check for signs of box swell. If the area near the bevel causes the straight edge to lift off, the counterbore diameter shall be checked in accordance with 10.28.5 and 10.28.6.

Using a mirror or portable light, illuminate the inside surface. Inspect for corrosion and other irregularities from both ends.

Measure and record the outside diameter 102 mm (4.0 in) from the shoulder for each box connection and the inside diameter 76 mm (3.0 in) from the end of the pin for each pin connection, and record on the work sheet.

Measure the length of the sub and fish neck on bottleneck subs. Record values on work sheet. Lengths on used subs shall be measured from shoulder to shoulder rather than end to end.

Check the radius of the section change on bottleneck subs using radius gauges. The radius shall be larger than the 38 mm (1.5 in) radius gauge and smaller than the 51 mm (2 in) radius gauge.

Check the markings for correctness and record the sub serial number on the inspection work sheet.

10.38.6 Evaluation and classification

Areas of surface imperfections deeper than 3,18 mm (0.125 in) shall be inspected for cracks using magnetic particles (10.13.10.2) on ferromagnetic materials or liquid-penetrant inspection (10.32) on non-ferromagnetic materials. Imperfections deeper than 3,18 mm (0.125 in) on the inside diameter under the pin threads or stress-relief groove or on the outside surface over the box threads or boreback shall be cause for rejection. Subs containing sharp-bottomed, transverse cuts or gouges in the body deeper than 6,4 mm (0.25 in) should be marked and reported to the owner/operator. Other conditions shall be recorded on the inspection work sheet for continued monitoring.

Areas of internal surface imperfections, such as deep gouges, shall be inspected for cracks using shear-wave ultrasonic techniques. Subs containing cracks shall be rejected.

The minimum length for a straight box-by-box sub is 610 mm (24 in). The minimum length for a straight box-by-pin sub is 406 mm (16 in). The minimum length for a straight pin-by-pin sub is 305 mm (12 in). The minimum length for a bottleneck sub is 914 mm (36.0 in) with the fish-neck length having a minimum length of 457 mm (18.0 in). Swivel subs have a minimum length of 178 mm (7.0 in). Subs not meeting the length requirement shall be rejected.

Bottleneck subs with a section-change radius less than 38 mm (1.5 in) or greater than 51 mm (2 in) shall be rejected.

10.39 Float-bore recess measurements

10.39.1 Description

Subs that have machined recesses for float bore are inspected for dimensional compliance to assure proper fit of the float valve.

10.39.2 Surface preparation

Clean the bit connection and float-valve recess. Take care to remove dried drilling fluid, scale, oil, grease, thread compound or similar deposits and/or coatings in the bit connection and recess areas.

10.39.3 Equipment

The following equipment is required:

- a) 250 mm metal rule with 0,5 mm divisions (or a 12 in rule with 1/64 in divisions) suitable for measurement of the recess length from the bit end of the sub;
- b) telescope gauge or inside micrometer, suitable for measurement of the diameter;
- c) long-reach, inside-diameter, mechanical calliper, which may be used in place of the telescope gauge and inside micrometer.

Metal rule, micrometers and dial callipers shall meet the requirements of Clause 9.

10.39.4 Standardization

Illumination shall meet the requirements of 9.3.2. A mirror or portable light shall be available for internal illumination.

10.39.5 Inspection procedure

Determine the valve-assembly diameter, length and bit-connection size employed in the bit sub being examined. See Figure 17 and Table C.14 (Table D.14) for standard dimensions of float-valve recesses and bit-connection sizes. Insert the metal rule into the recess until it reaches the back shoulder of the recess area. Note the distance, L_R (see Figure 17) from the back shoulder to the end of the sub at the outer edge of the bit connection. Compare that measurement to dimension L_R listed in Table C.14 (Table D.14). The recess length shall meet the requirement and tolerances of Table C.14 (Table D.14) to be acceptable for use.

Insert the inside-diameter measuring tool or instrument into the recess bore until it reaches near the back shoulder of the recess area. Obtain a measurement of the inside diameter at that location, take two measurements 90° apart to assure the concentricity of the recess diameter. Repeat the same measurements near the outer end on the bored surface of the recess. Compare those measurements to dimension D_{FR} listed in Table C.14 (Table D.14). The recess diameter shall meet the requirements and tolerances of Table C.14 (Table D.14) to be acceptable for use.

A visual inspection of the recess bore shall be performed to determine the surface condition of the recess area. Dried or caked drilling fluid, scale or any other surface coatings shall be removed prior to visual inspection. Visible mechanical damage, pitting, erosion, washing or evidence of any condition that can interfere with the hydraulic seal between the float valve and the surface of the recess area is not permitted and shall be cause for rejection.

Variations and combinations of bit subs, bit sizes and float-valve dimensions other than those found in Figure 17 and Table C.14 (Table D.14) can be used. In these cases, the establishment of acceptable float-valve recess dimensions should be a matter of discussion with the drill-string-component user or owner.

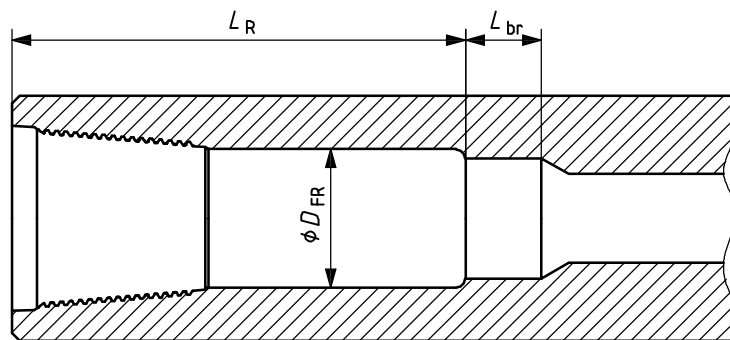

a) With baffle plate recess

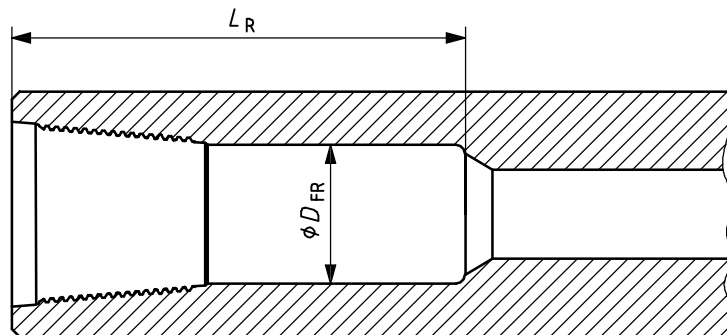

b) Without baffle plate recess

Figure 17 — Float-bore recess

10.40 Magnetic-particle inspection of subs — Full-length, internal and external

10.40.1 Description

In 10.40 the wet fluorescent-magnetic-particle inspection of the internal and external surfaces of subs is described for the detection of transverse and longitudinal, non-volumetric, surface-breaking flaws.

10.40.2 Equipment

10.40.2.1 Longitudinal field

An AC yoke or a coil, either AC or DC (HWAC, FWAC or filtered FWAC or pulsating DC, may be used for this inspection. The number of turns of the coil shall be clearly marked on the coil.

10.40.2.2 Transverse/circular field

An internal conductor with an appropriate power supply shall be used. The current for the internal conductor may be supplied with DC, a three-phase rectified AC power supply or capacitor-discharge power supply. The power supply shall be capable of meeting the amperage requirements of Table C.2 (Table D.2). Table C.18 (Table D.18) provides the mass per metre (foot) for various outside- and inside-diameter combinations for subs and drill collars.

10.40.2.3 Fluorescent-particle inspection

Fluorescent-magnetic-particle solutions shall comply with the requirements of 9.4.8.3. An ultraviolet light source, fluorescent magnetic particles, a 100 ml centrifuge tube (graduated in 0,05 ml increments) and an ultraviolet light meter are required. If particles are supplied as an aerosol, the centrifuge tube is not required.

10.40.2.4 Additional equipment

Additional equipment includes a magnetometer or gauss meter, and an inspection mirror, portable light or mirror for internal illumination.

10.40.2.5 Illumination

Illumination of the inspection surfaces for visual inspection shall comply with the requirements of 9.3.2. Illumination of the surfaces for fluorescent-magnetic-particle inspection shall comply with the requirements of 9.4.8.5.

10.40.3 Surface preparation

The inspection areas shall be cleaned of all grease, thread compound, dirt and any other foreign matter that can interfere with particle mobility, complete wetting of the surface by the particle carrier and indication detection.

Surface coatings (paint, etc.) shall be smooth and shall have a thickness equal to or less than 0,05 mm (0.002 in).

10.40.4 Calibration

Equipment calibration is covered in Clause 9.

10.40.5 Standardization

Select a sub for inspection. Place the DC coil over the sub approximately 229 mm (9.0 in) from the end of the pin threads or one of the box threads on a box-by-box sub. Energize the coil to establish a residual longitudinal field. Using the residual field, apply magnetic particles to the surface of the sub and observe the particle mobility. Adjust the field as high as possible without the particles being prematurely pulled out of suspension. Particle mobility should continue for at least 6 s. After the proper magnetic field has been established based on particle mobility, record the amperage required to establish the magnetic field. This amperage becomes the magnetizing level used for inspection.

NOTE It is possible that short subs and other components do not retain sufficient field to inspect using a residual field. If the maximum available magnetizing force is used and the proper particle mobility cannot be achieved, it is necessary to establish an active field magnetic field to the same criteria as above.

The magnetizing rod shall be completely insulated from the sub. Power-supply requirements in Table C.2 (Table D.2) shall be met. The current level specified in the table shall be the magnetizing current for the longitudinal inspection. Table C.18 (Table D.18) provides the mass per metre (foot) for various BHA outside- and inside-diameter combinations.

10.40.6 Inspection procedures

The steps for inspection found in this subclause are the minimum requirements and can vary depending upon the sub condition and the options agreed to between the owner and the agency.

A full-length visual inspection of the entire outside and inside surfaces shall be conducted to detect gouges, cuts, pits, dents, crushing and other visually detectable imperfections.

The DC coil shall be used to inspect for transverse indications. The magnetizing rod shall be used for detection of longitudinal indications.

The following steps are conducted in a darkened area (21,5 lx maximum visible light). The inspector shall be in the darkened area at least 1 min prior to beginning inspection to allow the eyes to adapt. Darkened lenses or photochromic lenses shall not be worn.

The inspection steps are as follows.

- a) Place the coil over the sub. The inspection area shall be no more than 229 mm (9.0 in) on either side of the coil for each coil placement. Place the coil within 229 mm (9.0 in) of the end of the sub. Magnetize the sub as established during standardization. Apply the magnetic-particle bath by gently spraying or flowing the suspension over the sub in the inspection area on both the inside and outside surfaces. Allow at least 6 s for indications to form and then perform a transverse magnetic-particle inspection on the inside and outside surfaces of the coverage area using the ultraviolet light. Roll the sub as required, inspecting 100 % of the surface in the area covered by that coil placement.
- b) Subsequent coil placement and inspection are required for full-length coverage.
- c) Place the internal conductor (magnetizing rod or cables) through the ID of the sub. Magnetize the sub as established during standardization. Apply the magnetic-particle bath by gently spraying or flowing the suspension over the sub. Allow at least 6 s for indications to form and perform a longitudinal magnetic-particle inspection on the inside and outside surfaces, along the full length, using the ultraviolet light. Roll the sub as required to inspect 100 % of the surface area.

10.40.7 Evaluation and classification

Any cracking shall be cause for rejecting the component. Cracks shall not be removed.

10.41 HWDP — Visual full-length OD and ID, markings and tong space

10.41.1 Description

The entire HWDP outside and inside surface is checked for damage and corrosion. Markings are verified and the serial number, if present, shall be recorded. The tong space shall be measured. Centre wear-pad minimum height and eccentricity shall be measured.

10.41.2 Surface preparation

All surfaces being examined shall be cleaned so that foreign material does not interfere with the detection process. The HWDP shall be positioned so it can be rolled one complete revolution.

10.41.3 Equipment

The following equipment is required:

- a) mirror or portable light, to illuminate the inside surface;
- b) tape measure or rule, to measure tong space;
- c) rule, graduated in 0,5 mm (or 1/64 in) increments.

10.41.4 Illumination

Illumination shall meet the requirements of 9.3.2.

10.41.5 Inspection procedure

Observe the HWDP outside diameter surface for signs of damage including but not limited to pits, cuts, dents, other mechanical damage and cracks. Place a straightedge along the outside diameter of the box tool-joint to check for signs of box swell. If the area near the bevel causes the straightedge to lift off, the counterbore diameter shall be measured in accordance with 10.28.5 and 10.28.6.

Using a mirror or portable light, illuminate the inside surface and inspect for corrosion and other irregularities from both ends.

Check the marking for correctness and record the HWDP serial number, if present, on the inspection work sheet.

Check the tong-space length by placing a rule on the upper-connection outside diameter and measure the distance from the seal face to the location of the hard-banding.

10.41.6 Evaluation and classification

Areas of surface imperfections deeper than 3,18 mm (0.125 in) shall be inspected for cracks using magnetic particles. Imperfections deeper than 3,18 mm (0.125 in) on the inside diameter under the pin threads or stress-relief groove or on the outside surface over the box threads or boreback shall be cause for rejection. HWDP containing sharp-bottomed, transverse cuts or gouges in the body deeper than 6,4 mm (0.25 in) shall be rejected. Other conditions shall be recorded on the inspection work sheet for continued monitoring. Magnetic-particle evaluation shall be in accordance to 10.13.10.2.

On HWDP with a centre wear pad, using a straightedge on the wear pad and extended over the HWDP tube body, search for the minimum and maximum centre wear-pad height. The difference between the minimum and maximum is the eccentricity. Centre wear pads not meeting the minimum height and eccentricity requirement agreed to by the owner/user shall be rejected.

Areas of internal surface imperfections, such as deep gouges, shall be inspected for cracks using shear-wave ultrasonic techniques. Ultrasonic crack characterization is covered in 10.13.10.2. HWDP containing cracks shall be rejected.

Tong-space length shall not be less than 254 mm (10.0 in) on the HWDP.

10.42 Visual inspection and wear pattern report for kelly

10.42.1 Description

The entire kelly outside surface is checked for damage, corrosion and wear pattern. Visually search for corkscrewed kellys. Markings are verified and the serial number recorded. The inside surfaces are checked to the extent possible with a mirror or portable light for corrosion. If applicable, tool-joint length and the distance between the sealing shoulder and the hard-banding or section change, shall be measured. Hard-banding, if present, is visually examined in accordance with 10.59. Check straightness as an optional service, when specified.

10.42.2 Surface preparation

All surfaces being examined shall be cleaned so that foreign material does not interfere with the detection process. Kellys shall be positioned so they can be turned for inspection of each side.

10.42.3 Equipment

The following equipment is required:

- a) mirror or portable light, to illuminate the inside surface;
- b) tape measure or rule, to measure tool-joint length;
- c) rule, graduated in 0,5 mm (or 1/64 in) increments;
- d) bevel protractor;
- e) heavy cord (optional), if required for straightness check;
- f) 120° V-blocks (optional), if required for straightness check on hexagonal kellys.

10.42.4 Illumination

Illumination shall meet the requirements of 9.3.2. A mirror or portable light shall be available for internal illumination.

10.42.5 Inspection procedure

Observe the kelly outside-diameter surface for signs of damage including but not limited to pits, cuts, dents, other mechanical damage and cracks. Place a straightedge along the outside diameter of the box connection to check for signs of box swell. If the area near the bevel causes the straightedge to lift off, the counterbore diameter shall be measured in accordance with 10.28.5 and 10.28.6.

Using a mirror or portable light, illuminate the inside surface. Inspect for corrosion and other irregularities from both ends.

Check the marking for correctness and record the serial number on the inspection work sheet.

Check the tool-joint length by placing a rule on the upper-connection outside diameter and measuring the distance from the seal face to the location of any section change.

Check the wear pattern on the kelly for length and flatness. The kelly wear pattern typically starts at a point of wear and progresses across the flat until it is about one third of the way across. The wear pattern characteristically remains flat as long as the bushings are the proper diameter and the spacing is correct. A rounded wear pattern or a high-angled wear pattern is an indication that the wear pattern is nearing the rollover point. Measure the contact angle at points of maximum roundness or high angle using a bevel protractor (see Figure 18). Record these angles on the work sheet.

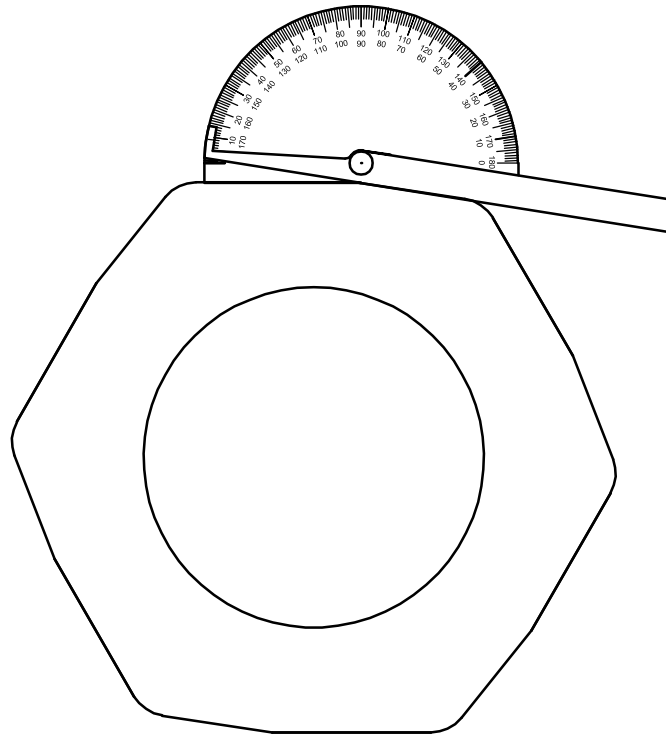

Figure 18 — Measurement of kelly wear-pattern angle

Check kelly straightness when specified by placing square kellys on level supports (one at each end of the drive section), stretching a heavy cord from one end of a vertical face of the square to the other, measuring deflection, rolling the kelly 90°, and repeating the procedure. On hexagonal kellys, use the same method except that it is necessary to place the kelly in 120° V-blocks so that the side face of the drive section is vertical and deflection measurements are taken on three successive sides (turning the kelly through 60° each time).

10.42.6 Evaluation and classification

Areas of surface imperfections deeper than 3,18 mm (0.125 in) shall be inspected for cracks using magnetic particles. Magnetic-particle evaluation shall be in accordance with 10.13.10.2. Imperfections deeper than 3,18 mm (0.125 in) on the inside diameter under the pin threads or stress-relief groove or on the outside surface over the box threads or boreback shall be cause for rejection. Other conditions shall be recorded on the inspection work sheet for continued monitoring.

Areas of internal surface imperfections, such as deep gouges, shall be inspected for cracks using shear-wave ultrasonic techniques. Kellys containing cracks shall be rejected.

The tool-joint length shall not be less than 254 mm (10.0 in).

If the deflection of the drive section as measured (the distance between the cord and the vertical drive section) exceeds 38 mm (1.5 in) at any place along the length of the drive section, the kelly shall be rejected.

10.43 Magnetic-particle evaluation of critical areas on kellys

10.43.1 Description

The external surface from the tool-joint taper to a point 610 mm (24 in) along the drive section is inspected with dry magnetic-particle inspection. The wet fluorescent-magnetic-particle method or white background and black-magnetic-particle wet method may be substituted for dry magnetic particles. This inspection is performed primarily to detect transverse cracks on the outside diameter surface of the kelly.

10.43.2 Procedure

This inspection is done according to the procedures described in 10.7.

10.43.3 Acceptance criteria

If any cracks are detected, the kelly shall be considered unfit for further drilling service.

10.44 Magnetic-particle evaluation, full length, of the drive section on kellys

10.44.1 Description

The external surface of the entire drive section is inspected with dry magnetic-particle inspection. Wet fluorescent-magnetic or white background and black-magnetic-particle wet methods may be substituted for dry magnetic particles. This inspection is performed primarily to detect transverse cracks on the outside diameter surface of the kelly.

10.44.2 Procedure

This inspection is done in accordance with the procedures described in 10.7 except that the inspection area is extended for the full length of the kelly.

10.44.3 Acceptance criteria

If any cracks are detected, the kelly shall be considered unfit for further drilling service.

10.45 Stabilizer (full-length visual OD and ID), fish-neck length, blade condition, ring gauge and markings

10.45.1 Description

The entire stabilizer outside and inside surface is checked for damage and corrosion. Blades are checked for height and ring-gauged. Verify that minimum fish-neck length requirements are met. Markings are verified and the serial number recorded.

NOTE For complete inspection, adjustable blade stabilizers and non-rotating blade stabilizers require complete disassembly so that the individual component can be inspected. This type of inspection is performed according to a maintenance programme in an OEM-authorized repair facility by qualified personnel using a proprietary tool-inspection procedure developed for the particular model of tool. This type of inspection is beyond the scope of this part of ISO 10407. Field inspection of these types of stabilizers is limited to the inspection of accessible surfaces.

10.45.2 Surface preparation

All surfaces being examined shall be cleaned so that foreign material does not interfere with the detection process. Stabilizers shall be positioned so they can be rolled one complete revolution.

10.45.3 Equipment

The following equipment is required:

- a) mirror or portable light, to illuminate the inside surface;
- b) tape measure, to measure the overall length and length of the fish-neck;
- c) metal rule, graduated in 0,5 mm divisions (or 1/64 in divisions);
- d) OD and ID callipers;
- e) straightedge, long enough to extend from blades to tube body;
- f) ring gauge, made from steel with a minimum thickness of 12,7 mm (0.5 in) and a width of 19,0 mm (0.75 in) for the stabilizer size;
- g) 25 mm (1.0 in) radius gauge, required for integral blade stabilizers.

10.45.4 Illumination

Illumination shall meet the requirements of 9.3.2. A mirror or portable light shall be available for internal illumination.

10.45.5 Calibration

The ring-gauge inside diameter shall be as specified with a tolerance of $\begin{matrix} +0,13 \text{ mm (0.005 in)} \\ 0 \end{matrix}$. The inside diameter shall be checked with internal micrometers meeting the calibration requirements of Clause 9.

10.45.6 Inspection procedure

Observe the stabilizer outside diameter surface for signs of damage including but not limited to pits, cuts, dents, other mechanical damage and cracks. If hard-banding is present on the blades, check the condition and coverage.

Using a mirror or portable light, illuminate the inside surface. Inspect for corrosion and other irregularities from both ends.

Measure and record the outside diameter 102 mm (4.0 in) from the shoulder for each box connection and the inside diameter 76 mm (3.0 in) from the end of the pin for each pin connection, and record on the work sheet.

Measure the length of the stabilizer and fish neck. Record values on the work sheet. Lengths on used stabilizers are measured from shoulder to shoulder rather than end to end.

Check the marking for correctness and record the stabilizer serial number on the inspection work sheet. If no stencil is present, the stabilizer shall be rejected.

Measure the height of the blade from the outside diameter. Place a straightedge along the top of the blade parallel to the stabilizer axis and extend the end over the stabilizer body. Measure the height of the blade from the straightedge to the stabilizer body and record on the work sheet. Repeat on both ends of each blade.

On integral blade stabilizers, check the radius at the intersection of the blade and stabilizer body using a radius gauge to assure that the radius is a minimum of 25 mm (1.0 in).

Pass the ring gauge over the length of the stabilizer blade. Observe the gap between the ring gauge and the blade. Measure the gap at the point of maximum gap.

10.45.7 Evaluation and classification

There shall be no welding on the heel or toe of the stabilizer blades. The areas of stabilizer surface having imperfections deeper than 3,18 mm (0.125 in) shall be inspected for cracks using magnetic particles (see 10.13.10.2) on ferromagnetic stabilizers or liquid penetrant (see 10.32) on non-ferromagnetic stabilizers. Imperfections deeper than 3,18 mm (0.125 in) on the inside diameter under the pin threads or stress-relief groove shall be cause for rejection. Stabilizers containing sharp-bottomed, transverse cuts or gouges in the body deeper than 6,4 mm (0.25 in) shall be rejected. Other conditions shall be recorded on the inspection work sheet.

Imperfections on the internal surface, such as deep gouges, shall be inspected for cracks. Stabilizers containing cracks shall be rejected.

The stabilizer fish-neck length shall be no less than 457 mm (18.0 in) on stabilizers with a body outside diameter less than or equal to 152 mm (6 in), and no less than 508 mm (20 in) on stabilizers with a body outside diameter larger than 152 mm (6 in). The stabilizer neck length of the lower end shall not be less than 203 mm (8 in) on stabilizers with body outside diameter 240 mm (9.5 in) or smaller, or 305 mm (12 in) on stabilizers with body outside diameter larger than 240 mm (9.5 in). Except for near bit stabilizers and adjustable gauge stabilizers, the minimum tong space for the lower neck shall not be less than 178 mm (7,0 in). Stabilizers not meeting the requirements shall be rejected.

If present, hard-banding shall cover a minimum of 95 % of the length of the stabilizer blade flat section. Linear indications are allowed in the hard-banding provided it does not extend into the base metal of the blades.

The difference between the minimum and maximum blade height shall not be more than 1,5 mm (1/16 in).

Ring gauge shall pass smoothly over the entire blade section. If more than 25 mm (1.0 in) of the blade section has a gap greater than 1,5 mm (1/16 in) between the gauge and blade, the stabilizer shall be rejected.

On integral blade stabilizers, the radius shall be 25 mm (1.0 in) or greater or the stabilizer shall be rejected.

10.46 Magnetic-particle inspection of the base of stabilizer blades for cracking

10.46.1 General

The stabilizer rotated under high lateral force against the formation can be damaged as a result of cyclic stresses. The area of the intersection between the blade base and the stabilizer body is subject to cracking because of these stresses. In 10.46, inspection procedures are established for the detection of any cracking present. The inspection method is normally done with dry magnetic particles, but may be done with fluorescent or visible light, utilizing a white background and the black visible magnetic-particle wet method.

10.46.2 Equipment

10.46.2.1 Transverse field

Use an AC yoke with articulated legs for this inspection.

10.46.2.2 Dry magnetic particles

Dry magnetic particles shall meet the requirements of 9.4.8.2. A powder bulb capable of applying magnetic particles in a light dusting shall be used.

If using the optional fluorescent-particle inspection or white background and black magnetic-particle wet method, use the appropriate equipment list and procedures from 10.48.

10.46.3 Illumination

Illumination of the inspection surfaces for visual inspection and visible-light magnetic-particle inspection shall comply with the requirements of 9.3.2.

10.46.4 Surface preparation

The inspection areas shall be cleaned of all grease, thread compound, dirt and any other foreign matter that can interfere with particle mobility and indication detection. When using the dry magnetic-particle techniques, all surfaces being inspected shall be powder dry.

Surface coatings (paint, etc.) shall be smooth and shall have a thickness equal to or less than 0,05 mm (0.002 in).

10.46.5 Calibration

Equipment calibration is covered in Clause 9.

10.46.6 Standardization**10.46.6.1 AC yoke**

Adjust the legs of the yoke to maximize contact with the stabilizer surface and the blade surface when positioned for the appropriate inspection direction. Legs shall be positioned 102 mm (4.0 in) to 152 mm (6.0 in) surface distance apart, if the stabilizer size and blade height allow.

10.46.6.2 Inspection procedures

The steps for inspection found in 10.46 are the minimum requirements and can vary depending upon the stabilizer condition and the options agreed to between the owner and the agency.

10.46.6.3 Inspection coverage requirements

On integral blade stabilizers, perform a magnetic-particle inspection on the base of the stabilizer blades completely around the blade. For welded blade stabilizers, perform magnetic-particle inspection the full length of the weld on both sides of all blades. The yoke shall be positioned so that the magnetic field is across the blade base.

10.46.6.4 Dry magnetic-particle method

The following steps are conducted in a lighted area (538 lx minimum visible light). Darkened lenses or photochromic lenses shall not be worn.

- a) Place the yoke on the stabilizer/stabilizer blade, maximizing contact with the yoke legs and the stabilizer.
- b) Energize the yoke and, while the current is on, apply the magnetic particles in a light cloud over the area between the legs of the yoke on the stabilizer OD.
- c) Allow at least 3 s for indications to form and then examine the area.
- d) If no indication is found, turn off the yoke and move it allowing for proper overlap, and repeat steps a) through c).

10.46.7 Evaluation and classification

Any cracking other than in the hard surfaces shall be cause to reject the stabilizer. Cracks shall not be removed.

10.47 Function test

10.47.1 Description

The manufacturer shall have a written and reviewable function-testing procedure. Function testing provides verification that a component or assembly is functioning in accordance within its design performance limits. Function tests normally fall into two major categories: operating function and pressure maintenance.

For hydraulic-load testing, the minimum testing hold times and test pressures shall be specified by the manufacturer.

The test may include a two- or three-step function test, including testing points at

- a) minimum expected operating load minus 20 %,
- b) maximum expected operating load, and
- c) rated load capacity.

If expected operating loads are not available, function test to

- minimum rated load capacity, and
- maximum rated load capacity.

The original equipment manufacturer is responsible for developing the function-test procedures for its equipment for both new and used conditions.

Safety precautions shall be detailed in the function test procedures.

10.47.2 Equipment

OEMs shall specify the required testing apparatus, calibration, detailed standardization procedures, test procedure and test acceptance limits.

Equipment shall meet the specification and calibration requirements. Any non-conformance with calibration or standardization shall be corrected prior to accomplishing the function test.

10.47.3 Preparation/conditions

Review the test procedure and ensure all safety precautions are in place.

Verify that the test is conducted with the equipment, as closely as possible, in its normal operating configuration. Additional O-rings on connections that are not present during normal operation shall not be allowed.

10.47.4 Procedure

Follow the OEM's test procedure.

10.47.5 Evaluation and classification

If the component fails to function once, the component shall be rejected. If the component does not function in an expected manner, the component shall be rejected. If any leaking occurs in a component that is supposed to maintain a seal, the component shall be rejected.

10.48 Bi-directional, wet magnetic-particle inspection of the base of stabilizer blade for cracking

10.48.1 General

The stabilizer rotated under high lateral force against the formation can be damaged as a result of cyclic stresses. The area of the intersection between the blade base and the stabilizer body is subject to cracking because of these stresses. In 10.48, inspection procedures are established for the detection of any cracking present. The inspection method may be the fluorescent wet method or the visible-light wet method utilizing a white background and black magnetic particles. Additional requirements can be found in the OEM requirements.

10.48.2 Equipment

10.48.2.1 General

The required equipment includes an AC yoke with articulated legs.

10.48.2.2 Fluorescent-particle inspection

Fluorescent-magnetic-particle solutions shall comply with the requirements of 9.4.8.3. An ultraviolet light source, fluorescent magnetic particles, a 100 ml centrifuge tube (graduated in 0,05 ml increments) and an ultraviolet light meter are required. If the particles are supplied as an aerosol, the centrifuge tube is not required.

10.48.2.3 White background and black magnetic particles

Aerosol materials for the white background and black magnetic-particle wet inspection shall be from the same manufacture or specified as compatible by the product manufacturer and used in accordance with the manufacturer's requirements.

10.48.3 Illumination

Illumination of the inspection surfaces for visual inspection and visible-light magnetic particle inspection shall comply with the requirements of 9.3.2.

Illumination of the surfaces for fluorescent magnetic-particle inspection shall comply with the requirements of 9.4.8.5.

10.48.4 Surface preparation

The inspection areas shall be cleaned of all grease, thread compound, dirt and any other foreign matter that can interfere with the particle mobility, complete wetting of the surface by the particle carrier and indication detection.

Surface coatings (paint, etc.), including the white background coating if the white background and black magnetic particle system is used, shall be smooth and shall have a thickness equal to or less than 0,05 mm (0.002 in).

10.48.5 Calibration

Equipment calibration is covered in Clause 9.

10.48.6 AC yoke standardization

Adjust the legs of the yoke to maximize contact with the stabilizer surface and the blade surface when positioned for the appropriate inspection direction.

10.48.7 Inspection procedures

10.48.7.1 General

The steps for inspection found in 10.48.7 are the minimum requirements and can vary depending upon the stabilizer condition and the options agreed to between the owner and the agency.

10.48.7.2 Inspection coverage requirements

10.48.7.2.1 Integral blade stabilizer

Perform a bi-directional magnetic particle inspection on 100 % of the body and blades in the blade area and 152 mm (6.0 in) of the body (360° around) on each end of the blades. Pay special attention during magnetic-particle inspection for cracks extending from the hard metal into the body or base metal.

10.48.7.2.2 Welded-blade steel stabilizer

Perform a bi-directional magnetic particle inspection on 100 % of the body in the blade area, 100 % of all welds and 152 mm (6.0 in) of the body (360° around) on each end of the blade. Pay special attention during the MT for cracks extending out of the welds into the body, defective welds (i.e. lack of fusion) and cracks on the body due to welds from previous positioning of the blades.

10.48.7.2.3 Adjustable steel blade stabilizer

This inspection should not be attempted without a manufacture's maintenance procedures. The adjustable stabilizer shall be completely disassembled prior to inspection. The OEM inspection procedures shall be followed for the inspection of components. Additionally, all major components shall be inspected as detailed in this subclause.

Perform a bi-directional magnetic-particle inspection on the transition areas and/or stress areas located on the top sub and mandrel with collet, all drilled holes in the stabilizer body, 100 % of the stabilizer body and blades in the blade area and 152 mm (6.0 in) of the body (360° around) on each end of the blades. Pay special attention during MT for cracks in or around the drilled holes and cracks extending from the hard metal into the body or base metal.

10.48.7.2.4 Non-rotating-blade stabilizer

This inspection should not be attempted without a manufacturer's maintenance procedures. The non-rotating-blade stabilizer shall be completely disassembled prior to inspection. The OEM inspection procedures shall be followed for the inspection of components. Additionally, all major components shall be inspected as detailed in this subclause.

Perform a bi-directional magnetic-particle inspection on the transition areas, stress areas and/or welds located on the stabilizer mandrel body, top sub and stabilizer sleeve (unless the sleeve is rubber). Pay special attention during the MT for cracks extending out of the welds into the stabilizer sleeve, defective welds (i.e. lack of fusion) and cracks on the stabilizer sleeve due to welds from previous positioning of the blades.

10.48.7.3 Fluorescent method

This inspection is done in a darkened area (21,5 lx maximum visible light). The inspector shall be in the darkened area at least 1 min prior to beginning the inspection to allow eyes to adapt. Darkened lenses or photochromatic lenses shall not be worn.

The inspection steps are as follows.

- a) Place the yoke on the stabilizer/stabilizer blade, maximizing contact with the yoke legs and the stabilizer.
- b) Energize the yoke and, while the current is on, apply the magnetic-particle bath by gently spraying or flowing the suspension over the stabilizer OD in the magnetized area.
- c) Allow at least 3 s for indications to form and then examine the area using ultraviolet light while still applying the current.
- d) If no indication is found turn off the yoke and move it, allowing for proper overlap, and repeat steps a) through c).
- e) Continue to inspect and move until the entire required inspection area on the stabilizers has been covered.
- f) Inspect the entire area again with the legs of the yoke orientated 90° from the direction of the first inspection, following the same procedures as above.
- g) Roll the stabilizer and inspect successive areas until 100 % of the required areas of the stabilizer OD surface have been inspected in the two directions, 90° apart.

10.48.7.4 White background and black magnetic-particle wet method

This inspection is done in a lighted area (538 lx minimum visible light). Darkened lenses or photochromatic lenses shall not be worn. White contrast background materials shall be applied to the entire stabilizer outside diameter, excluding hard-banding, in a light, even coat. Care shall be taken not to damage the background coating during handling, until inspection is complete.

The inspection steps are as follows.

- a) Place the yoke on the stabilizer/stabilizer blade, maximizing contact with the yoke legs and the stabilizer.
- b) Energize the yoke and, while the current is on, apply the magnetic-particle bath by gently spraying or flowing the suspension over the stabilizer OD in the magnetized area.
- c) Allow at least 3 s for indications to form and then examine the area while still applying the magnetizing current.
- d) If no indication is found, turn off the yoke and move it, allowing for proper overlap, and repeat steps a) through c).
- e) Continue to inspect and move until the entire required inspection area on the stabilizers has been covered.
- f) Inspect the entire area again with the legs of the yoke orientated 90° from the direction of the first inspection, following the same procedures as above.
- g) Roll the stabilizer and inspect successive areas until 100 % of the stabilizer OD surface has been inspected.

10.48.8 Evaluation and classification

Any cracking other than in the hard surfaces shall be cause to reject the stabilizer. Cracks shall not be removed.

10.49 Visual inspection of jars (drilling and fishing), accelerators and shock subs

10.49.1 Description

The entire tool outside and accessible inside surface is checked for mechanical damage and corrosion. Observable components are visually inspected for damage, wear and corrosion. Markings are verified and serial number recorded. A review of OEM requirements provides additional visual-inspection requirements.

NOTE For complete inspection, tool disassembly and individual component inspection are required. This type of inspection is performed according to a maintenance programme in an OEM-authorized repair facility by qualified personnel using a proprietary tool-inspection procedure developed for the particular model of tool. This type of inspection is beyond the scope of this part of ISO 10407.

10.49.2 Surface preparation

All surfaces being examined shall be clean so that foreign material does not interfere with the detection process. Drill stem elements shall be positioned so that they can be rolled one complete revolution.

10.49.3 Equipment

The following equipment is required:

- a) mirror or portable light, to illuminate the inside surface;
- b) tape measure, to measure overall length and length of fish neck;
- c) metal rule with 0,5 mm (or with 1/64 in) divisions;
- d) OD and ID callipers.

10.49.4 Illumination

Illumination shall meet the requirements of 9.3.2.

10.49.5 Inspection procedure

Observe the tool outside diameter surface for signs of damage including but not limited to pits, cuts, dents, other mechanical damage and cracks. If hard-banding is present on the blades, check the condition and coverage.

Using a mirror or portable light, illuminate the inside surface. Inspect for corrosion and other irregularities from both ends.

Measure and record the outside diameter 102 mm (4.0 in) from the shoulder for each box connection and the inside diameter 76 mm (3.0 in) from the end of the pin for each pin connection, and record on the work sheet.

Measure the length of the tool and fish neck. Record the values on the work sheet. Lengths on used tools are measured from shoulder-to-shoulder rather than end-to-end.

Check the marking for correctness and record the tool serial number on the inspection work sheet. If no stencil is present, the tool shall be rejected.

10.49.6 Evaluation and classification

Any corrosion, cuts, gouges or erosion on sealing areas shall be cause for rejection. There shall be no flaking or peeling of chrome surfaces. Other imperfections shall be classified according to the criteria established by the OEM. Imperfections not addressed by the OEM inspection procedure shall be rejected.

10.50 Maintenance review

10.50.1 Description

The manufacturer shall have written and reviewable maintenance procedures as well as a description of authorized repairs. Maintenance logs provide verification that a component or assembly has been maintained in accordance with standards and a record of all authorized repairs made to the component. The maintenance review is verification that the component has been maintained in accordance with the original manufacturer's specifications.

The original equipment manufacturer is responsible for developing the maintenance procedures for its equipment for both new and used conditions.

10.50.2 Preparation/conditions

Prior to beginning the maintenance review, the inspector shall obtain and review the OEM's maintenance procedures and any authorized repair procedures. Additionally, the inspector shall obtain the maintenance logs for the specific component under review.

10.50.3 Procedure

Review maintenance logs for compliance with the maintenance requirements. Verify that time-change elements have been replaced in a timely manner with OEM-approved replacement parts. Verify that the required inspections have been completed and that no unauthorized repairs have been made.

Examine the component for evidence of unauthorized repairs, improper handling, shipping or storage.

10.50.4 Evaluation and classification

Any irregularities in the maintenance or repair records or physically on the component shall be cause to reject the component.

10.51 Dimensional measurement of wear areas as specified by OEM requirements

10.51.1 Description

The manufacturer shall provide dimensional requirements and tolerances for all components whose wear can affect fit, form or function of the component and sub-component. Load-path components require dimensional information and tolerances for both new and used components.

The original equipment manufacture (OEM) is responsible for developing the acceptance criteria and inspection procedures for its equipment for both new and used conditions.

10.51.2 Equipment

The OEM shall specify the required measurement tools. Calibration shall be in accordance with Clause 9 or as specified by the manufacturer, whichever is the most stringent calibration. Detailed standardization and measurement procedure shall be provided by the OEM.

Any non-conformance with calibration or standardization shall be corrected prior to carrying out the measurement.

10.51.3 Preparation/conditions

All surfaces being examined shall be clean so that foreign material does not interfere with the measurement process.

10.51.4 Procedure

Complete all measurements following the OEM's measurement procedure.

10.51.5 Evaluation and classification

If any measurement is not in the acceptable range, the component shall be rejected.

10.52 Original equipment manufacturer designated testing for used equipment

10.52.1 Description

The manufacturer may require special tests to validate the usability of used equipment. In such cases, a written and reviewable testing procedure shall be available.

Safety precautions shall be detailed in the function test procedures.

10.52.2 Equipment

The OEM shall specify the required testing apparatus, calibration, detailed standardization procedures, test procedure and test acceptance limits.

Equipment shall meet the specification and calibration requirements. Any non-conformance with calibration or standardization shall be corrected prior to carrying out the function test.

10.52.3 Preparation/conditions

Review the test procedure and ensure that all safety precautions are in place.

Verify that the test is conducted with the equipment, as closely as possible, in its normal operating configuration. Additional O-rings on connections that are not present during normal operation shall not be allowed.

10.52.4 Procedure

Follow the OEM's test procedure.

10.52.5 Evaluation and classification

If the component fails to meet OEM requirements once, the component shall be rejected.

10.53 MWD/LWD — Visual, full-length OD and ID, and markings, including visual inspection of hard-banding and coatings

10.53.1 Description

The outside and accessible inside surfaces of MWD/LWD components are checked for mechanical damage and corrosion. Observable components are visually inspected for damage, wear and corrosion. Hard-banding, if present, is visually examined in accordance with 10.59. Markings are verified and the serial number recorded. A review of OEM requirements provides additional visual-inspection requirements.

NOTE For complete inspection, tool disassembly and individual component inspection are required. This type of inspection is performed according to a maintenance programme in an OEM-authorized repair facility by qualified personnel using a proprietary tool-inspection procedure developed for the particular model of tool. This type of inspection is beyond the scope of this part of ISO 10407.

10.53.2 Surface preparation

All surfaces being examined shall be cleaned so that foreign material does not interfere with the detection process. Drill stem elements shall be positioned so they can be rolled one complete revolution.

10.53.3 Equipment

The following equipment is required:

- a) mirror or portable light, to illuminate the inside surface;
- b) tape measure or rule, to measure tong space;
- c) straightedge.

10.53.4 Illumination

Illumination shall meet the requirements of 9.3.2. A mirror or portable light shall be available for internal illumination.

10.53.5 Inspection procedure

Observe the component outside-diameter surface for signs of damage including but not limited to pits, cuts, dents, other mechanical damage, and cracks.

Using a mirror or portable light, illuminate the inside surface. Inspect for corrosion and other irregularities from both ends.

Check the marking for correctness and record the component serial number on the inspection work sheet.

Check the fish-neck length by placing a rule or tape measure on the upper-connection outside diameter and measuring the distance from the seal face to the location of any section change.

10.53.6 Evaluation and classification

Areas of surface imperfections deeper than 3,18 mm (0.125 in) shall be inspected for cracks using magnetic particles (see 10.13.10.2) on ferromagnetic materials or liquid penetrant (see 10.32) on non-ferromagnetic materials. Imperfections deeper than 3,18 mm (0.125 in) on the inside diameter under the pin threads or stress-relief groove or on the outside surface over the box threads or boreback shall be cause for rejection. MWD/LWD components containing sharp-bottomed, transverse cuts or gouges in the body deeper than 6,4 mm (0.25 in) shall be rejected. Other conditions shall be recorded on the inspection work sheet for continued monitoring.

Areas of internal surface imperfections, such as deep gouges, shall be inspected for cracks, using shear-wave ultrasonic techniques, or magnetic particles for ferromagnetic materials or liquid penetrant on non-ferromagnetic materials. Drill stem elements containing cracks shall be rejected.

Fish-neck length shall not be less than 254 mm (10 in).

10.54 Motors and turbines — Visual, full-length OD and ID and markings, including visual inspection of hard-banding and coatings

10.54.1 Description

The entire tool outside and accessible inside surfaces are checked for mechanical damage and corrosion. Observable components are visually inspected for damage, wear and corrosion. Hard-banding, if present, is visually examined in accordance with 10.59. Markings are verified and the serial number recorded. A review of OEM requirements provides additional visual-inspection requirements.

NOTE For complete inspection, tool disassembly and individual component inspection are required. This type of inspection is performed according to a maintenance programme in an OEM-authorized repair facility by qualified personnel using a proprietary tool-inspection procedure developed for the particular model of tool. This type of inspection is beyond the scope of this part of ISO 10407.

10.54.2 Surface preparation

All surfaces being examined shall be cleaned so that foreign material does not interfere with the detection process. Drill stem elements shall be positioned so they can be rolled one complete revolution.

10.54.3 Equipment

The following equipment is required:

- a) mirror or portable light, to illuminate the inside surface;
- b) tape measure or rule, to measure the tong space.

10.54.4 Illumination

Illumination shall meet the requirements of 9.3.2. A mirror or portable light shall be available for internal illumination.

10.54.5 Inspection procedure

Observe the component outside diameter surface for signs of damage including but not limited to pits, cuts, dents, other mechanical damage and cracks.

Using a mirror or portable light, illuminate the inside surface. Inspect for corrosion and other irregularities from both ends.

Check the marking for correctness and record the component serial number on the inspection work sheet.

Check the fish-neck length by placing a rule on the upper-connection outside diameter and measuring the distance from the seal face to the location of any section change.

10.54.6 Evaluation and classification

Areas of surface imperfections deeper than 3,18 mm (0.125 in) shall be evaluated for cracks using magnetic particles (see 10.13.10.2) on ferromagnetic materials or liquid penetrant (see 10.32) on non-ferromagnetic motors or turbines. Imperfections deeper than 3,18 mm (0.125 in) on the inside diameter under the pin threads or stress-relief groove or on the outside surface over the box threads or boreback shall be cause for rejection. Motors or turbines containing sharp-bottomed, transverse cuts or gouges in the body deeper than 6,4 mm (0.25 in) shall be rejected. Other conditions shall be recorded on the inspection work sheet for continued monitoring.

Areas of internal surface imperfections, such as deep gouges, shall be inspected for cracks using shear-wave ultrasonic techniques, magnetic particles on ferromagnetic materials or liquid penetrant (see 10.32) on non-ferromagnetic motors or turbines. Drill stem elements containing cracks shall be rejected.

Fish-neck length shall not be less than 254 mm (10 in).

10.55 Reamers, scrapers, and hole openers — Visual, full-length OD and ID and markings, including visual inspection of hard-banding and coatings

10.55.1 Description

The entire reamer, scraper or hole-opener assembly outside and accessible inside surfaces are checked for mechanical damage and corrosion. Observable components are visually inspected for damage, wear and corrosion. Hard-banding, if present, is visually examined in accordance with 10.59. Markings are verified and the serial number recorded. A review of OEM requirements provides additional visual-inspection requirements.

NOTE For complete inspection, tool disassembly and individual component inspection are required. This type of inspection is performed according to a maintenance programme in an OEM-authorized repair facility by qualified personnel using a proprietary tool-inspection procedure developed for the particular model of tool. This type of inspection is beyond the scope of this part of ISO 10407.

10.55.2 Surface preparation

All surfaces being examined shall be cleaned so that foreign material does not interfere with the detection process. Drill stem elements shall be positioned so they can be rolled one complete revolution.

10.55.3 Equipment

The following equipment is required:

- a) mirror or portable light, to illuminate the inside surface;
- b) tape measure or rule, to measure tong space.

10.55.4 Illumination

Illumination shall meet the requirements of 9.3.2. A mirror or portable light shall be available for internal illumination.

10.55.5 Inspection procedure

Observe the component outside-diameter surface for signs of damage including but not limited to pits, cuts, dents, other mechanical damage and cracks.

Using a mirror or portable light, illuminate the inside surface. Inspect for corrosion and other irregularities from both ends.

Check the marking for correctness and record the component serial number on the inspection work sheet.

Check the fish-neck length by placing a rule on the upper-connection outside diameter and measuring the distance from the seal face to the location of any section change.

10.55.6 Evaluation and classification

Areas of surface imperfections deeper than 3,18 mm (0.125 in) shall be inspected for cracks using magnetic particles (see 10.13.10.2) on ferromagnetic materials or liquid penetrant (see 10.32) on non-ferromagnetic reamers, scrapers or hole openers. Imperfections deeper than 3,18 mm (0.125 in) on the inside diameter

under the pin threads or stress-relief groove or on the outside surface over the box threads or boreback shall be cause for rejection. Reamers, scrapers or hole openers containing sharp-bottomed, transverse cuts or gouges in the body deeper than 6,4 mm (0.25 in) shall be rejected. Other conditions shall be recorded on the inspection work sheet for continued monitoring.

Areas of internal surface imperfections, such as deep gouges, shall be inspected for cracks using shear-wave ultrasonic techniques, magnetic particles or liquid penetrant. Drill stem elements containing cracks shall be rejected.

Fish-neck length shall not be less than 254 mm (10,0 in).

10.56 Rotary steerable — Visual, full-length OD and ID and markings, including visual inspection of hard-banding

10.56.1 Description

The rotary steerable assembly outside and accessible inside surfaces are checked for mechanical damage and corrosion. Observable components are visually inspected for damage, wear and corrosion. Hard-banding, if present, is visually examined in accordance with 10.59. Markings are verified and the serial number recorded. A review of OEM requirements provides additional visual-inspection requirements.

NOTE For complete inspection, tool disassembly and individual component inspection are required. This type of inspection is performed according to a maintenance programme in an OEM-authorized repair facility by qualified personnel using a proprietary tool-inspection procedure developed for the particular model of tool. This type of inspection is beyond the scope of this part of ISO 10407.

10.56.2 Surface preparation

All surfaces being examined shall be cleaned so that foreign material does not interfere with the detection process. Drill stem elements shall be positioned so they can rolled one complete revolution.

10.56.3 Equipment

The following equipment is required:

- a) mirror or portable light, to illuminate the inside surface;
- b) tape measure or rule, to measure tong space.

10.56.4 Illumination

Illumination shall meet the requirements of 9.3.2. A mirror or portable light shall be available for internal illumination.

10.56.5 Inspection procedure

Observe the component outside diameter surface for signs of damage including but not limited to pits, cuts, dents, other mechanical damage and cracks.

Using a mirror or portable light, illuminate the inside surface and inspect for corrosion and other irregularities from both ends.

Check the marking for correctness and record the component serial number on the inspection work sheet.

Check the fish-neck length by placing a rule or tape measure on the upper-connection outside diameter and measuring the distance from the seal face to the location of any section change.

10.56.6 Evaluation and classification

Areas of surface imperfections deeper than 3,18 mm (0.125 in) shall be inspected for cracks using magnetic particles (see 10.13.10.2) on ferromagnetic materials or liquid penetrant (see 10.32) on non-ferromagnetic rotary steerable. Imperfections deeper than 3,18 mm (0.125 in) on the inside diameter under the pin threads or stress-relief groove or on the outside surface over the box threads or boreback shall be cause for rejection. Rotary steerable containing sharp-bottomed, transverse cuts or gouges in the body deeper than 6,4 mm (0.25 in) shall be rejected. Other conditions shall be recorded on the inspection work sheet for continued monitoring.

Areas of internal surface imperfections, such as deep gouges, shall be inspected for cracks using shear-wave ultrasonic, magnetic particles or liquid-penetrant techniques. Drill stem elements containing cracks shall be rejected.

Fish-neck length shall not be less than 254 mm (10 in).

10.57 Full-length drift

10.57.1 Description

In 10.57 full-length drifting of drilling equipment is covered to ensure the free passage of down-hole tools through the product once it is in the well.

This inspection shall not be applied to drill stem elements having internal functional parts that do not allow a free passage for other equipment through the bore during drilling.

10.57.2 Equipment

The following equipment is required.

- a) drift mandrel, cylindrical in shape with a rounded or tapered leading edge to permit easy entry into the pipe, with the drift of the proper length and diameter;
- b) precision calliper, capable of measuring the drift diameter to a hundredth of a millimetre (thousandth of an inch);
- c) steel rule, of sufficient length to measure the drift length.

10.57.3 Calibration

Micrometer, calliper and steel rule shall be calibrated in accordance with Clause 9.

10.57.4 Standardization

Prior to starting, measure the diameter of the drift mandrel using a micrometer or calliper that displays the readout to a hundredth of a millimetre (thousandth of an inch) and record the dimensions. Measure the drift mandrels from 25 mm (1.0 in) from both ends, but not on the taper, and then again every 203 mm (8.0 in) from there with a minimum of two readings at each point, 90° apart. These measurements should be made with both the drift and the micrometer at the same temperature.

Measure the length of the cylindrical portion (excluding the area bevels or end rounding) of the drift mandrel with a steel scale and record the dimension.

Bar-bell or disc mandrels are not accepted.

Additional standardization checks for drift diameter shall be accomplished after every 200 joints and after completion of the inspection. All lengths drifted between an unacceptable check and the most recent acceptable check shall be re-drifted with a proper drift.

Dimensions shall meet the requirements of the OEM, as appropriate, or as agreed with the owner/user.

10.57.5 Inspection procedures

10.57.5.1 Preparation

The equipment being drifted shall be free of foreign matter and shall be properly supported to prevent sagging. The drift mandrel for use shall be within $\pm 11,1$ °C (± 20 °F) of the temperature of the pipe being inspected.

10.57.5.2 Procedure

The drift mandrel shall be inserted and removed in a manner to avoid damage to threaded ends. If thread protectors allow drifting, the protectors shall be left on.

The drift mandrel should pass through the entire length using an exerted force that does not exceed the weight of the mandrel.

If the mandrel strikes the ground during drifting operation, the mandrel shall be cleaned and checked for dings or damage prior to re-drifting.

10.57.6 Evaluation and classification

If the drift mandrel does not pass through an entire length that has been properly cleaned and supported, the length shall be considered a reject and identified as a "no drift".

10.58 Proprietary equipment inspection

10.58.1 Description

There are many proprietary specialty tools used in the drill stem including jars, under-reamers, safety valves and internal blowout preventer valves, wash pipe, liner-hanger running tools, packers, storm valves, cementing stands, coring equipment, diverter tools, etc. Where these tools are not covered by International Standards, inspection should be done in accordance with the OEM instructions. The OEM instructions shall provide damage, wear and corrosion tolerances for all parts that effect fit and/or the function of the assembly. If complete inspection is required, the tool shall be disassembled at the shop prior to inspection and the inspection done in accordance with the manufacturer's inspection procedures. Field inspection of assembled tools is limited to an examination of the tool outside and accessible inside surface, checking for mechanical damage, wear and corrosion. Additionally, the fish-neck length and overall length are measured and recorded. Markings are verified and the serial number is recorded.

10.58.2 Surface preparation

All surfaces being examined shall be clean so that foreign material does not interfere with the detection process. Drill-stem elements shall be positioned so that they can be rolled one complete revolution.

10.58.3 Equipment

The following equipment is required:

- a) mirror or portable light, to illuminate the inside surface;
- b) tape measure, to measure overall length and length of fish neck;
- c) metal rule, with 0,5 mm (or 1/64 in) divisions;
- d) OD and ID callipers.

10.58.4 Illumination

Illumination shall meet the requirements of 9.3.2.

10.58.5 Inspection procedure

Observe the tool outside-diameter surface for signs of damage including but not limited to pits, cuts, dents, other mechanical damage and cracks. If hard-banding is present on the blades, check the condition and coverage.

Using a mirror or portable light, illuminate the inside surface. Inspect for corrosion and other irregularities from both ends.

Measure the outside diameter 102 mm (4.0 in) from the shoulder for each box connection and the inside diameter 76 mm (3.0 in) from the end of the pin for each pin connection, and record on the work sheet.

Measure the length of the tool and the fish neck. Record values on the work sheet. Lengths on used tools are measured from shoulder-to-shoulder rather than end-to-end.

Check the marking for correctness and record the tool serial number on the inspection work sheet. If no stencil is present, the tool shall be rejected.

10.58.6 Evaluation and classification

Any corrosion, cuts, gouges or erosion on sealing areas shall be cause for rejection. There shall be no flaking or peeling of chrome surfaces. Other imperfections shall be classified according to the criteria established by the OEM. Imperfections not addressed by the OEM inspection procedure shall be cause for rejection.

10.59 Hard-banding inspection

10.59.1 General

In 10.59 the inspection acceptance and rejection criteria are specified for hard-banding applied to drill pipe, HWDP, drill collars and other bottom-hole-assembly (BHA) components. Hard-banding is not normally an integral component of the structural integrity of the drill stem element and, therefore, acceptance or rejection is determined by the owner/operator. Inspection is a visual examination of the surface for service-induced degradation or other defects. Because of the wide variety of materials used for hard-banding on these tools and the different applications encountered by different owner/users, these criteria are general. Specific owner/users may have additional criteria to apply to specific materials and operating conditions. These additional criteria can include inspection methods other than visual examinations (such as MT or PT, for example) and, when requested, these additional inspections are performed as specified by the owner/user.

Tungsten carbide hard-banding is the most abrasive, wear-resistant hard-banding product in use. Typically, this type of hard-banding does not exhibit any cracking after it is applied; disbonding of this type of hard-banding from the tool-joint surface is very rare. Tungsten carbide hard-banding products may be applied flush with adjacent surfaces or "raised" above adjacent surfaces. In both cases, tungsten carbide hard-banding can be, and is often, re-applied over the top of itself without having to remove whatever hard-banding remains. When this type of hard-banding is re-applied in this manner, some cracking and porosity can occur, but cracking is not commonly encountered, and it generally does not make a difference in the durability of this hard-banding. However, porosity is a common occurrence in tungsten carbide hard-banding and excessive porosity can promote erosion and fluid washing within the hard-banded area.

Most "casing-friendly" hard-banding products are allowed some degree of cracking. However, the acceptability of such cracking varies greatly from one product to another, depending on the hard-banding product manufacturer's specifications. The applicator-specific inspection acceptance and rejection criteria that pertain to the hard-banding product being inspected apply. A best practice is for the applicator to share this information with the pipe owner/user prior to conducting inspections so that the acceptance and rejection criteria are understood and agreed to by the owner/user. If the type of hard-banding that is applied to new or

used drill pipe, HWDP, drill collars and other BHA components is not known, or if, for any reason, the hard-banding applicator does not provide sufficient inspection criteria required to conduct a conclusive inspection, the criteria specified in 10.59.2 to 10.59.5 shall be used to accept or reject hard-banding, regardless of whether the hard-banding is newly applied or has been exposed to drilling operations since it was applied initially.

10.59.2 Preparation

Areas being inspected shall be clean and free from all dirt, thread dope, grease, rust, paint, lint and other types of foreign materials that can limit and interfere with the inspection process and accuracy. For newly applied hard-banding, the surface shall be allowed to cool to below 50 °C (150 °F) prior to inspection.

10.59.3 Equipment

The following equipment is required:

- a) bevel protractor;
- b) a metal rule, graduated in 0,5 mm (or 1/64 in) increments;
- c) straightedge and depth gauge, fitted with needle contact.

A non-permanent marker, such as chalk, may be used to identify areas requiring evaluation.

10.59.4 Illumination

Illumination shall meet the requirements of 9.3.2.

10.59.5 Inspection procedure

Each hard-banded area shall be visually inspected for imperfections on the entire hard-banded surface. This inspection may be done as a separate inspection or in conjunction with other required visual inspections of the drill stem element.

Inspect for visually detectable imperfections. Imperfections include but are not limited to cracks, porosity, blow holes, craters, raised carbide chips, missing or broken pieces, improper shape of weld bead and improper depth of valley between passes.

When cracks or missing sections are detected visually, they shall be examined to be sure that the material adjacent to the crack is not beginning to separate from the base material.

All detected cracks shall be examined to verify that they terminate within the weld bead and do not extend to the base material at either end of the hard-banding deposit.

Porosity shall be considered excessive when three or more holes are seen within a 12,7 mm (0.500 in) diameter area and the distance between the holes is less than the diameter of the holes. Excessive porosity can result in a loss of wear resistance of the hard-banding and can cause erosion and/or fluid washing within the hard-banding itself. The owner/user shall be notified of this condition.

In addition to the above for "casing-friendly" hard-banding, the hard-banding applied to the 18° elevator taper area of the box tool joints on drill pipe and HWDP shall be examined to verify there is a distinctly discernable shoulder with the tool joint OD around the entire circumference. This area is also checked for flushness of the hard-banding with the adjacent surface of the taper and evidence of incorrect shoulder angle. A straightedge placed along the length of the shoulder aids in detection of flushness and angle.

10.59.6 Evaluation and classification procedures

10.59.6.1 General

Any drill pipe, HWDP, drill collars or BHA components that have hard-banding rejected based on the criteria specified below shall be marked and set aside for owner/user disposition.

10.59.6.2 Criteria applicable to all hard-banding

All cracks that can be proven to have propagated into the parent material shall be cause for rejection.

Any hard-banding that appears not to be properly bonded or adhering to the surface to which it was applied shall be rejected. This condition can be manifested by visual indications of the hard-banding weld deposit showing signs of lifting from the surface to which it was applied.

The outside diameter of the hard-banding shall be visually examined to determine how much is left. If the hard-banding is worn through at any place along its length, the diameter of the tool at that location should be checked to be sure that it is within allowable tolerances. If the diameter is within acceptable tolerances, the condition of the hard-banding shall be noted as "worn" on the inspection report, but unless otherwise specified by the owner/user, this shall not be a cause for rejection.

10.59.6.3 Criteria for tungsten carbide hard-banding

Cracking confined to the hard-banding metal is acceptable. Carbide chips protruding from the surface of the hard-banding shall be cause for rejection.

The owner/user may apply additional acceptance/rejection criteria. These can include but are not limited to

- a) the area of coverage to which the hard-banding is applied,
- b) the dimension and tolerances of the extent to which the hard-banding shall be flush with or raised above adjacent surfaces,
- c) the width of the weld deposit, and the depth and width of the valleys between weld passes,
- d) the concavity of the weld bead,
- e) the extent of allowable surface imperfections, such as pinholes, blow holes, and craters,
- f) the size and shape of the tungsten carbide particles being used, and
- g) any acceptable or unacceptable cracking on the surface of the finished hard-banding.

10.59.6.4 Criteria for the inspection of "casing-friendly" hard-banded surfaces

10.59.6.4.1 General

Any drill pipe, HWDP, drill collars or BHA components that have hard-banding rejected based on the criteria specified in 10.59.6.4.2 to 10.59.6.4.6 shall be marked and set aside for owner/user disposition.

10.59.6.4.2 Crack width

Rejection criteria are as follows:

- if the width of any single longitudinal or oblique crack is greater than 1,0 mm (0.040 in);
- if the width of any single transverse or circumferential cracking is greater than 0,025 mm (0.010 in).

10.59.6.4.3 Porosity (pin holes)

Pinholes that are greater than 1,6 mm (0.062 in) in diameter and more than 1,6 mm (0.062 in) in depth shall be rejected.

10.59.6.4.4 Bead overlap and flatness

Beads should overlap slightly to prevent excessive valleys between adjacent beads. Valleys between adjacent beads should not be greater than 1,59 mm (0.062 in) wide, measured from valley top edges, or greater than 3,17 mm (0.125 in) deep. Bead shape should be flat to slightly convex. Concavity at the centre of a bead should not exceed 0,4 mm (0.015 in).

10.59.6.4.5 User/owner criteria

Inspectors contracted to inspect “casing-friendly” hard-banding should consult with the user/owner for additional criteria based on the specific hard-banding used and field experience with that hard-banding.

The additional criteria may include criteria limiting the length and number of cracks. Examples of additional criteria include but are not limited to the following:

- a) where there are more than three longitudinal cracks that are as long as the width of a weld bead, regardless of crack width, that are concentrated within a continuous circumferential band length of 25 mm (1 in) around the circumference of the object where hard-banding is applied;
- b) where two longitudinal cracks that are as long as the width of a weld bead are closer together than 6 mm (0.250 in) at any point, and one or both of them is/are greater than 0,5 mm (0.020 in) in width;
- c) if any single continuous longitudinal crack is longer than 50 mm (2.0 in);
- d) where transversely oriented cracks intersect with more than one longitudinal or oblique crack;
- e) where obliquely oriented cracks intersect both a longitudinal and a transverse crack.

10.59.6.4.6 Hard-banding applied to the 18° elevator taper area of the box tool joints on drill pipe and HWDP

The acceptance and rejection criteria for the hard-banded surface of the 18° elevator taper area on box tool joints on drill pipe and HWDP shall be as follows.

- a) The transition between the 18° elevator taper and the tool joint OD shall have a discernable corner around the entire circumference where the tool-joint outside diameter and the elevator taper intersect.
- b) If evidence of an incorrect angle is revealed during inspection, the 18° elevator taper shall be measured with a bevel protractor and shall be within $+2^{\circ}_0$ tolerance or shall be rejected.
- c) The hard-banded surface on the 18° elevator taper shall be flush with the adjacent surface of the taper to a tolerance of $+0,8_0$ mm $\left(+\frac{1}{32}_0$ in) or shall be rejected.
- d) Any hard-banding that appears not to be properly bonded or adhering to the surface to which it was applied shall be rejected.

10.60 Transverse magnetic-particle inspection of tool-joint OD and ID under the pin threads

10.60.1 General

In 10.60 equipment requirements, descriptions and procedures are provided for wet fluorescent-magnetic-particle inspection of the external surface from the sealing shoulder to the small end of the tapered shoulder and the area under the pin threads on used drill-pipe tool joints. This inspection is performed to detect transverse cracks.

10.60.2 Equipment

10.60.2.1 Coil

A DC (HWAC, FWAC or filtered FWAC or pulsating DC) coil shall be used for this inspection. The number of turns of the coil shall be clearly marked on the coil.

10.60.2.2 Fluorescent-particle inspection

Fluorescent-magnetic-particle solutions shall comply with the requirements of 9.4.8.3. An ultraviolet light source, fluorescent magnetic particles, a 100 ml centrifuge tube (with 0,05 ml increments) and an ultraviolet light meter are required. If the particles are supplied as an aerosol, the centrifuge tube is not required.

10.60.2.3 Additional equipment

The following equipment is required:

- a) magnetometer or gauss meter;
- b) inspection mirror, portable light or mirror, for internal illumination.

10.60.3 Illumination

Illumination of the inspection surfaces for visual inspection shall comply with the requirements of 9.3.2. Illumination of the surfaces for fluorescent-magnetic-particle inspection shall comply with the requirements of 9.4.8.5.

10.60.4 Surface preparation

The inspection areas shall be cleaned of all grease, thread compound, dirt and any other foreign matter that can interfere with the particle mobility, complete wetting of the surface by the particle carrier and indication detection.

Surface coatings (paint, etc.) shall be smooth and shall have a thickness equal to or less than 0,05 mm (0.002 in).

10.60.5 Calibration

Equipment calibration is covered in Clause 9.

10.60.6 Standardization

Select a typical tool joint from the string for inspection. Place the DC coil over the tool joint no more than 229 mm (9.0 in) from the sealing shoulder. Energize the coil to establish a residual longitudinal field. Using the residual field, apply magnetic particles to the inspection area and observe the particle mobility. If the magnetic particles continue to flow for longer than 10 s, increase the magnetic field strength and reapply magnetic particles. If the magnetic particles are pulled out of suspension prematurely, i.e. within an interval shorter than 6 s, reverse the coil and apply slightly less current. Continue until the magnetic particle mobility is from 6 s to 10 s after application.

After the proper magnetic field has been established based on particle mobility, measure the field at the end of the connection using a gauss meter or magnetometer. The field in each subsequent connection shall be within 10 % of the established field strength.

10.60.7 Inspection procedures

The steps for inspection in this subclause are the minimum requirements and can vary depending upon the drill-pipe condition and the options agreed between the owner and the agency. Visible-light inspection of the threads is required prior to the ultraviolet-light inspection.

The following steps are to be conducted in a darkened area (21,5 lx maximum visible light). Inspectors shall be in the darkened area at least 1 min prior to beginning inspection to allow eyes to adapt. Darkened lenses or photochromic lenses shall not be worn.

- a) Place the coil over the tool joint so as to provide coverage to the sealing shoulder.
- b) Energize the coil with the magnetizing current level established during standardization for at least 1 s. Turn the coil off.
- c) Apply the magnetic-particle bath by gently spraying or flowing the suspension over the magnetized inspection area. Using ultraviolet light, examine the inspection area on the top half of the connection. Rotate the tool joint 180° and reapply the particles. Using ultraviolet light, examine the threaded area on the top half of the connection.
- d) If necessary, move the coil to the next area on the tool joint and repeat steps a) to c).

Remove magnetic particles after inspection.

10.60.8 Evaluation

All tool-joint threads containing a crack other than in the hard-banding, regardless of depth, shall be rejected. The hard-banding shall be evaluated in accordance with 10.59.

10.60.9 Repair of rejected tool joints

For the repair of rejected tool joints, see 10.16.

10.61 Drill-pipe body — Internal magnetic-particle inspection of the critical area

10.61.1 General

In 10.61 the equipment requirements, descriptions and procedures are provided for dry magnetic-particle inspection of the internal surface of the critical area on used drill-pipe tubes. This inspection is performed primarily to detect transverse cracks on the inside-diameter surface of the pipe. This inspection is also applied to HWDP. These inspection procedures may be applied to BHA drill stem elements to cover specific areas.

For the purposes of this part of ISO 10407, the critical area extends from the base of the tapered shoulder of the tool joint to a plane located 660 mm (26.0 in) away or to the end of the slip marks, whichever is greater. On HWDP, the area on either side of the centre wear pad is outside the scope of this inspection.

10.61.2 Equipment

10.61.2.1 Coils

A longitudinal magnetic field produced by a coil shall be used for this inspection. DC (FWAC, HWAC, filtered FWAC or DC) coils may be used.

10.61.2.2 Dry magnetic particles

Dry magnetic particles shall meet the requirements of 9.4.8.2. A non-ferromagnetic trough that reaches the end of the critical area is required to distribute the particles over the area being inspected.

10.61.2.3 Optical inspection instrument

The equipment required includes a borescope or other optical internal inspection device meeting the requirements of 9.3.2.4.

10.61.3 Surface preparation

The inspection areas shall be cleaned of all grease, thread compound, dirt and any other foreign matter that can interfere with the particle mobility and indication detection. All surfaces being inspected shall be dry.

Surface coatings shall be smooth and shall have a thickness equal to or less than 0,05 mm (0.002 in).

10.61.4 Calibration

Equipment calibration is covered in Clause 9.

10.61.5 Standardization — DC coil

Select a typical pipe from the string for inspection. Place the coil on the pipe with the centreline approximately 305 mm (12.0 in) from the tapered shoulder. Energize the coil as specified in Table C.1 (Table D.1) based on the outside diameter of the pipe. Apply magnetic particles to the critical area with a non-ferromagnetic trough and, using a borescope, observe any magnetic-particle build-up (furring) in the inspection area. If there is no magnetic-particle build-up, use the specified amperage for inspection. If there is a magnetic-particle build-up, reverse the coil and apply slightly less current. Continue until only a light magnetic-particle build-up develops in the inspection area. Record the amperage required to establish this magnetic field; this becomes the amperage for the magnetizing level used for the inspection.

10.61.6 Inspection procedures — Steps for inspection

The steps for inspection in this subclause are the minimum requirements and can vary depending on the drill-pipe condition and the options agreed between the owner and the agency.

The steps for inspection are as follows.

- a) Inspect the entire internal critical area for visually detectable imperfections.
- b) Place the coil over the first area being inspected.
- c) The maximum coverage area for each coil placement is 305 mm (12.0 in) on either side of the coil centreline.
- d) Multiple placements are required to inspect the entire area.
- e) Energize the coil with the magnetizing current level established during standardization for at least 1 s.
- f) Turn the coil off.
- g) Apply magnetic particles to the entire critical area using the non-ferromagnetic trough and rolling the pipe to distribute them around the entire circumference.
- h) Conduct a magnetic-particle inspection of the viewable area covering the inspection area [maximum 305 mm (12.0 in) on either side of the coil centreline] using the optical inspection instrument. Rotate the pipe sufficiently to view the area under the powder line at the bottom of the pipe. Pay particular attention to the root of any cuts, gouges, or corrosion pits.
- i) Repeat the process with at least a 51 mm (2 in) overlap until the entire area being inspected has been covered.
- j) Remove magnetic particles after inspection.

10.61.7 Evaluation

Evaluate all imperfections in accordance with 10.13.

10.62 Drill-pipe body — Bi-directional, internal magnetic-particle inspection of the critical area

10.62.1 General

In 10.62 equipment requirements, descriptions and procedures are provided for magnetic-particle inspection of the internal surface of the critical area on used drill-pipe tubes. This inspection is performed to detect transverse and longitudinal cracks on the inside-diameter surface of the pipe. This inspection is also applied to HWDP. These inspection procedures may be applied to BHA drill stem elements to cover specific areas as well.

For the purposes of this part of ISO 10407, the critical area is from the base of the tapered shoulder of the tool joint to a plane located 660 mm (26.0 in) away or to the end of the slip marks, whichever is greater (see Figure 4). On HWDP, the area on either side of the centre wear pad is not included in this inspection.

10.62.2 Equipment

10.62.2.1 Longitudinal field

A DC (HWAC, FWAC or filtered FWAC or pulsating DC) coil shall be used for this inspection. The number of turns of the coil shall be clearly marked on the coil.

10.62.2.2 Circular field

An internal conductor may be used. The current for the internal conductor may be supplied with DC, a three-phase, rectified AC power supply or capacitor-discharge power supply. The power supply shall be capable of meeting the amperage requirements of Table C.2 (Table D.2). Table C.4 (Table D.4) provides the nominal linear mass [mass per metre (foot)] for various pipe sizes.

10.62.2.3 Dry magnetic particles

Dry magnetic particles shall meet the requirements of 9.4.8.2. A non-ferromagnetic trough that reaches the end of the critical area is required to distribute the particles over the area to be inspected.

10.62.2.4 Optical-inspection instrument

The equipment required includes a borescope or other optical internal-inspection device meeting the requirements of 9.3.2.4.

10.62.3 Surface preparation

The inspection areas shall be cleaned of all grease, thread compound, dirt and any other foreign matter that can interfere with the particle mobility and indication detection. All surfaces being inspected shall be dry.

Surface coatings shall be smooth and shall have a thickness equal to or less than 0,05 mm (0.002 in).

10.62.4 Calibration

Equipment calibration is covered in Clause 9.

10.62.5 Standardization

10.62.5.1 DC coil

Select a typical pipe from the string for inspection. Place the coil on the pipe with the centreline approximately 305 mm (12.0 in) from the tapered shoulder. Energize the coil as specified in Table C.1 (Table D.1) based on the outside diameter of the pipe. Apply magnetic particles to the critical area with a non-ferromagnetic trough and, using a borescope, observe any magnetic-particle build-up (furring) in the inspection area. If there is no magnetic particle build-up, use the specified amperage for inspection. If there is a magnetic-particle build-up, reverse the coil and apply slightly less current. Continue until only a light magnetic-particle build-up is present in the inspection area. Record the amperage required to establish the magnetic field; this becomes the amperage for the magnetizing level used for the inspection.

10.62.5.2 Magnetizing rod

The magnetizing rod shall be completely insulated from the pipe. Power-supply requirements in Table C.2 (Table D.2) shall be met. The current level specified in the table shall be the magnetizing current for the longitudinal inspection.

When using DC current, the pipe being magnetized shall be insulated for any current path to ground.

10.62.6 Inspection procedures

10.62.6.1 General

Inspect the entire internal critical area for visually detectable imperfections.

10.62.6.2 Coil

Place the coil over the pipe OD approximately 305 mm (12 in) from the tool-joint tapered shoulder. Magnetize the critical area as established during standardization, apply the magnetic particles to the entire critical area using the non-ferromagnetic trough and rolling the pipe to distribute them around the entire circumference. Using the optical-inspection instrument, conduct a magnetic-particle inspection of the visible area covering the inspection area [maximum 305 mm (12.0 in) on either side of the coil centreline]. Rotate the pipe sufficiently to view the area under the powder line at the bottom of the pipe. Pay particular attention to the root of any cuts, gouges, or corrosion pits.

Repeat the process with at least a 51 mm (2 in) overlap until the entire area being inspected has been covered. Inspect until 100 % of the critical-area inside-diameter surface has been inspected.

10.62.6.3 Magnetizing rod

Magnetize the pipe. Using the magnetic particles that were applied for the transverse inspection, roll the pipe one complete revolution to redistribute the magnetic particles. Using the optical-inspection instrument, conduct a magnetic-particle inspection of the visible critical area. Rotate the pipe sufficiently to view the area under the powder line at the bottom of the pipe. Inspect until 100 % of the critical-area inside-diameter surface has been inspected.

10.62.7 Post-inspection

Remove the magnetic particles after inspection.

10.62.8 Evaluation

Evaluate all imperfections in accordance with 10.13.

10.63 API external upset-thread connection inspection

10.63.1 General

In 10.63 the visual inspection of API EUE round threads used in a tubing work-string application is covered. It includes the inspection of the face, the chamfer, L_C area and non- L_C areas of the pin and the face, counterbore, perfect thread length and unengaged thread area of the box. Additionally, the power-tight make-up of attached couplings and coupling length is measured.

10.63.2 Equipment

The following equipment is required:

- a) metal rule, with 0,5 mm (or 1/64 in) divisions;
- b) small, hand-held, non-magnifying mirror;
- c) hardened and ground profile gauge;
- d) lead gauge, with proper setting standard and contacts.

10.63.3 Surface preparation

All surfaces being examined shall be cleaned so that foreign material does not interfere with the inspection process.

10.63.4 Calibration

Lead gauges shall be calibrated at least every 6 months and when they have been subjected to unusual shock that can affect the accuracy of the gauge.

10.63.5 Illumination

Illumination shall meet the requirements of 9.3.2.

10.63.6 Inspection procedure

Roll the work tubing at least one revolution while observing the pin connection. Observe the face, chamfer and threads for signs of damage including but not limited to pits, cuts, dents and galling.

Observe the inside diameter under the pin threads for pits, wireline cuts, erosion and sharp section changes.

Roll the work tubing again while observing the box connection. Observe the face, counterbore and threads for signs of damage including but not limited to pits, cuts, dents and galling.

Observe the outside of the coupling for grip marks, hammer marks, cuts, gouges and wear. Additionally, if the grade is present and legible, verify that the coupling is of the proper grade.

Measure the power-tight make-up by placing a metal rule on the inside of the coupling and measuring the distance from the face of the made-up pin to the face of the coupling.

A thread profile gauge shall be used to inspect the condition of the thread profile of both the pin and the box for wear. The inspector shall look for visible light between the gauge and the thread flanks, roots and crest. Two thread profile checks 90° apart shall be made on each connection. All detected imperfections or gaps on the profile gauge shall be marked and evaluated using the lead gauge.

Measure the coupling length.

10.63.7 Evaluation and classification

Any protrusion on a thread flank or crest throughout the pin and box thread length that causes interference with the profile gauge shall be repaired or shall be cause for rejection. Repairs shall be made only by agreement between the agency and the owner/operator.

An arc burn in any thread shall be cause for rejection.

L_c threads and the perfect thread length of the coupling (Table C.16 or Table D.16) shall be free of any imperfection that breaks the continuity of the thread. Imperfections that break the continuity of the threads include but are not limited to pits, cuts, dents, chatter, grinds, broken threads, non-full-crested threads and galling. Minor chatter, tears, cuts or other surface irregularities on the crest or roots of threads are not cause for rejection as long as threads have proper clearance. Minor surface roughness on the thread flanks is expected on used connections and is not cause for rejection unless it breaks the continuity of the thread.

L_c threads and the perfect thread length of the coupling that exhibit an improper thread form under examination with a profile gauge shall be rejected.

10.63.8 Chamfer and face

A connection shall be rejected if the chamfer is not present for the full 360° around the circumference, or if the thread runs out on the face and not the chamfer, or if the chamfer is excessive and produces a knife edge (razor edge) on the face of the pipe.

The face of the pin and coupling and counterbore of the coupling shall be free of burrs or the connection shall be rejected.

Power-tight make-up shall be within the range specified in Table C.16 (Table D.16) or the connection shall be rejected.

The coupling length shall not be less than the minimum length specified in Table C.16 (Table D.16) or the coupling shall be rejected.

Annex A (normative)

Original equipment manufacturer (OEM) requirements

A.1 OEM requirements for specialized tools

The intention of this annex is to define the minimum expectation of the OEMs for the inspection and qualification of their tools. The actual OEM documentation should exceed the requirements of this specification.

A.2 Dimensional requirements and tolerances

A.2.1 General

A schematic profile and list of inspection dimensional requirements and tolerances that can affect fit, form or function of the component and sub-components is required.

A.2.2 Load-path designation

Tools that carry string loads are inspected in accordance with a shop manual (repair and maintenance documents).

The inspection dimensional requirements and tolerances are required for inspection of these components.

A.2.3 Connections

A.2.3.1 General

All API or proprietary connections shall have a dimensional requirement, including tolerances for new and used applications.

A.2.3.2 Recut API connections

All recut end connections shall comply with the latest edition of ISO 10424-1.

NOTE For the purposes of this provision, API Spec 7-1 is equivalent to ISO 10424-1.

A.2.3.3 Internal and/or proprietary connections

All internal and proprietary connections shall comply with manufacturer's dimensional requirements for critical-service drill stem elements.

A.2.4 Pressure and function tests

When applicable, pressure and function test procedures shall be included to qualify the ability of the tool to function properly and/or maintain a load.

A.3 Vendor/supplier requirements for specialized tools

The intention of this clause is to define the minimum expectation of the vendor or supplier for the inspection and qualification of the tools they provide. The actual vendor-supplied documentation should exceed the requirements of this part of ISO 10407.

The minimum vendor/supplier documentation shall include the following.

- The vendor/supplier shall have a copy of the OEM documentation listed in Clause A.2 for review during the qualification and inspection process of each specialized tool or component.
- For rented or reused tools, the vendor/supplier should track the usage and repair history of each component or sub-component in a specialized tool and make this available to all inspection personnel.
- The vendor/supplier should provide operators with application, operating and handling instructions.
- The vendor/supplier should provide transportation representatives with the correct transportation and handling procedures.

Annex B (normative)

Required and additional inspections by product and class of service

Required and additional inspections by product and class of service are given in Tables B.1 to B.19.

NOTE Because of the additional equipment, inspector qualifications and time required to conduct the inspection, moderate and critical inspection services normally have a substantial additional cost compared to a standard inspection service.

Table B.1 — Pipe-body field inspection available for used drill pipe (UDP)

Inspection	Procedure (reference subclause)	Standard inspection	Moderate inspection	Critical inspection	Additional services
Full-length visual	10.1	X	X	X	—
OD gauging	10.2	X	X	X	—
UT wall measurement	10.3	X ^a	X ^a	—	—
Full-length EMI	10.4	X ^b	X ^b	—	—
Full-length ultrasonic (transverse and wall thickness)	10.5	X ^b	X ^b	—	—
Critical full-length ultrasonics (transverse, longitudinal and wall thickness)	10.6	—	—	X	—
MT critical area	10.7	X	X	—	—
MT critical area, external bi-directional	10.8	—	—	X	—
Full-length wall monitoring	10.9	—	X	X	—
UT of critical area ^d	10.10	—	X ^c	—	—
Calculation of the minimum cross-sectional area	10.11	—	—	—	X
Documentation review	10.12	—	—	—	X
MT critical area, internal	10.61	—	—	—	X
MT critical area, internal bi-directional	10.62	—	—	—	X

^a Not required if performing full-length ultrasonic wall measurement.

^b Either EMI or FLUT may be used for a specified wall thickness of 12,7 mm (0.500 in) or thinner. FLUT is required on tubes with a wall thickness greater than 12,7 mm (0.500 in).

^c Not required when performing procedure 10.5 or 10.6.

^d By agreement, procedure 10.61 or 10.62 may be substituted.

Table B.2 — Used tool-joint field inspections available ^a

Inspection	Procedure (reference subclause)	Standard inspection	Moderate inspection	Critical inspection	Additional services
Visual inspection of bevels, seals, threads, weight code/grade markings and outside diameter	10.14	X	X	X	—
Inspect hard-banding	10.59	X	X	X	—
Check for box swell and pin stretch	10.15	X	X	X	—
Check pin and box ODs and eccentric wear	10.17	X	X	—	—
Measure pin and box ODs and check eccentric wear	10.18	—	—	X	—
Check pin and box-tong space	10.19	X	X	—	—
Measure pin and box-tong space	10.20	—	—	X	—
MT of pin threads	10.21	—	X	X	—
MT of box threads	10.22	—	—	X	—
Measure pin inside diameter	10.23	—	—	X	—
MT of OD for heat-check cracks	10.24	—	X	—	—
MT of OD for heat-check cracks, bi-directional, wet MT only	10.25	—	—	X	—
Transverse MT of tool-joint OD and ID under the pin threads	10.60	—	—	X	—
Measure counterbore depth, pin-base length, seal width and check shoulder flatness, check tapered shoulder angle and elevator contact area	10.26	—	—	—	X

^a Used proprietary connections are inspected according to the manufacturer's inspection specifications. General guidelines are provided in Annex F for double-shoulder connections and dovetail-thread-form connections.

Table B.3 — Bottom-hole-assembly connection field inspections available

Inspection	Procedure (reference subclause)	Standard inspection	Moderate inspection	Critical inspection	Additional services
Visual inspection of bevels, seals, threads, and stress-relief features	10.27	X	X	X	—
Measure pin ID, box OD, counterbore diameter and benchmark location	10.28	X	X	X	—
Check bevel diameter	10.29	X	X	—	—
Measure bevel diameter	10.30	—	—	X	—
MT of pin and box threads	10.31	X ^a	X ^a	X ^a	—
PT of pin and box threads	10.32	X ^a	X ^a	X ^a	—
Dimensional measurement of stress-relief features	10.33	—	—	X	X
Measure counterbore depth, pin length and pin-neck length	10.34	—	—	—	X
^a For non-magnetic drill stem elements, substitute “liquid penetrant” (see 10.32) for “magnetic particle”.					

Table B.4 — Drill-collar inspections available, other than connections^a

Inspection	Procedure (reference subclause)	Standard inspection	Moderate inspection	Critical inspection	Additional services
Visual full-length, tong space, fish-neck length and markings	10.35	X	X	X	—
Inspect hard-banding	10.59	X	X	X	—
MT of OD for heat-check cracks, bi-directional, wet method only	10.25	—	—	X ^b	X
MT of elevator groove and slip recess	10.36	—	X	X	—
Elevator groove and slip recess dimensional	10.37	—	X	X	—
Document review (traceability)	10.12	—	—	X	X
^a Connection inspections required according to Table B.3 shall be conducted in addition to the BHA inspection shown in this table.					
^b For non-magnetic drill stem elements, substitute “liquid penetrant” (see 10.32) for “magnetic particle”.					

Table B.5 — Sub inspections available, other than connections ^a

Inspection	Procedure (reference subclause)	Standard inspection	Moderate inspection	Critical inspection	Additional services
Visual inspection full-length, fish neck and section-change radius	10.38	X	X	X	—
Inspect hard-banding	10.59	X	X	X	—
MT of OD for heat-check cracks, bi-directional, wet method only	10.25	—	—	X ^b	—
Float-bore recess, dimensional	10.39	—	X	X	—
MT full-length ID and OD of subs having a section change	10.40	—	—	X ^b	—
MT full-length OD for transverse	10.7	—	—	—	X
MT full-length ID for transverse	10.61	—	—	—	X
Document review (traceability)	10.12	—	—	X	X

^a Connection inspections required according to Table B.3 shall be conducted in addition to the BHA inspection shown in this table.

^b For non-magnetic drill stem elements, substitute "liquid penetrant" (see 10.32) for "magnetic particle".

Table B.6 — HWDP inspections available, other than connections ^a

Inspection	Procedure (reference subclause)	Standard inspection	Moderate inspection	Critical inspection	Additional services
Visual full-length, tool-joint OD, centre wear pad and tong space	10.41	X	X	X	—
Inspect hard-banding	10.59	X	X	X	—
Magnetic-particle inspection of the critical area	10.7	X	X	X	—
Magnetic-particle inspection of the tool-joint OD for heat-check cracks, bi-directional, wet method	10.25	—	—	X	—
UT critical area	10.10	—	—	X	—
Document review (traceability)	10.12	—	—	X	X

^a Connection inspections required according to Table B.3 shall be conducted in addition to the BHA inspection shown in this table.

Table B.7 — Kelly/top drive inspections available, other than connections ^a

Inspection	Procedure (reference subclause)	Standard inspection	Moderate inspection	Critical inspection	Additional services
Visual full-length and wear pattern report and optional straightness check	10.42	X	X	X	—
MT critical area	10.43	X	X	X	—
MT full length of drive section	10.44	—	X	X	—
Document review (traceability)	10.12	—	—	—	X

^a Connection inspections required according to Table B.3 shall be conducted in addition to the BHA inspection shown in this table.

Table B.8 — Stabilizer inspections available, other than connections ^a

Inspection	Procedure (reference subclause)	Standard inspection	Moderate inspection	Critical inspection	Additional services
Visual full-length, fish-neck length, marking, ring gauge and blade-wear check	10.45	X	X	X	—
MT base of blades	10.46	X	X	—	—
Function test on adjustable blades, OEM	10.47	—	—	X	—
MT base of blades, bi-directional, wet	10.48	—	—	X	—
Document review (traceability)	10.12	—	—	X	—

^a Connection inspections required according to Table B.3 shall be conducted in addition to the BHA inspection shown in this table.

Table B.9 — Jar (drilling and fishing), accelerator and shock sub inspections available, other than connections ^a

Inspection	Procedure (reference subclause)	Standard inspection	Moderate inspection	Critical inspection	Additional services
Visual full-length	10.49	X	X	X	—
Maintenance review as specified by OEM	10.50	—	X	X	—
Function test as specified by OEM	10.47	—	X	X	—
Dimensions of wear areas per OEM requirements	10.51	—	X	X	—
All OEM-designated testing for used equipment	10.52	—	—	X	—
Document review (traceability)	10.12	—	—	X	X

^a Connection inspections required according to Table B.3 shall be conducted in addition to the BHA inspection shown in this table.

Table B.10 — MWD/LWD inspections available, other than connections ^a

Inspection	Procedure (reference subclause)	Standard inspection	Moderate inspection	Critical inspection	Additional services
Visual full-length	10.53	X	X	X	—
Maintenance review as specified by OEM	10.50	—	X	X	—
Function test as specified by OEM	10.47	—	—	X	—
Dimensions of wear areas per OEM requirements	10.51	—	X	X	—
All OEM-designated testing for used equipment	10.52	—	—	X	—
Document review (traceability)	10.12	—	—	X	X

^a Connection inspections required according to Table B.3 shall be conducted in addition to the BHA inspection shown in this table.

Table B.11 — Motor and turbine inspections available, other than connections ^a

Inspection	Procedure (reference subclause)	Standard inspection	Moderate inspection	Critical inspection	Additional services
Visual full-length	10.54	X	X	X	—
Maintenance review as specified by OEM	10.50	—	X	X	—
Function test as specified by OEM	10.47	—	—	X	—
Dimensions of wear areas per OEM requirements	10.51	—	X	X	—
All OEM-designated testing for used equipment	10.52	—	—	X	—
Document review (traceability)	10.12	—	—	X	X

^a Connection inspections required according to Table B.3 shall be conducted in addition to the BHA inspection shown in this table.

Table B.12 — Reamer, scraper and hole-opener inspections available, other than connections ^a

Inspection	Procedure (reference subclause)	Standard inspection	Moderate inspection	Critical inspection	Additional services
Visual full-length	10.55	X	X	X	—
Maintenance review as specified by OEM	10.50	—	X	X	—
Function test as specified by OEM	10.47	—	—	X	—
Dimensions of wear areas per OEM requirements	10.51	—	X	X	—
All OEM-designated testing for used equipment	10.52	—	—	X	—
Document review (traceability)	10.12	—	—	X	X

^a Connection inspections required according to Table B.3 shall be conducted in addition to the BHA inspection shown in this table.

Table B.13 — Rotary steerable equipment inspections available, other than connections ^a

Specialty tool inspection	Procedure (reference subclause)	Standard inspection	Moderate inspection	Critical inspection	Additional services
Visual full-length, fish-neck length, marking and blade-wear check	10.56	X	X	X	—
Maintenance review as specified by OEM	10.50	—	X	X	—
Function test as specified by OEM	10.47	—	—	X	—
Dimensions of wear areas per OEM requirements	10.51	—	X	X	—
All OEM-designated testing for used equipment	10.52	—	—	X	—
Document review (traceability)	10.12	—	—	X	X

^a Connection inspections required according to Table B.3 shall be conducted in addition to the BHA inspection shown in this table.

Table B.14 — Proprietary equipment inspections available, other than connections ^a

Specialty tool inspection	Procedure (reference subclause)	Standard inspection	Moderate inspection	Critical inspection	Additional services
Visual full-length, fish-neck length, marking and blade-wear check	10.58	X	X	X	—
MT base of blades	10.46	X	—	—	—
Bi-directional wet magnetic particle of blade and blade area	10.48	—	X	X	—
MT full-length	10.7	—	—	X	X
MT full-length, bi-directional	10.8	—	—	X	X
UT wall measurement as specified by OEM	10.3	X	X	X	—
Full-length drift as specified by OEM	10.57	X	X	X	—
Inspect hard-banding	10.59	X	X	X	—
Maintenance review as specified by OEM	10.50	—	X	X	—
Function test as specified by OEM	10.47	X	X	X	—
Dimensions of wear areas per OEM requirements	10.51	—	X	X	—
All OEM-designated testing for used equipment	10.52	—	—	X	—
Document review (traceability)	10.12	—	X	X	X

^a Connection inspections required according to Table B.3 shall be conducted in addition to the BHA inspection shown in this table.

Table B.15 — Used work-string tubing ^a

Specialty tool inspection	Procedure (reference subclause)	Standard inspection	Moderate inspection	Critical inspection	Additional services
Full-length visual	10.1	X	X	X	—
OD gauging	10.2	X	X	X	—
UT of wall measurement	10.3	X ^b	X ^b	X ^b	—
Full-length EMI	10.4	X	X	—	—
Full-length ultrasonic (transverse and wall thickness)	10.5	X ^b	X ^b	—	—
Critical full-length ultrasonic (transverse, longitudinal and wall thickness)	10.6	—	—	X	—
MT of critical area	10.7	—	X	X	—
Full-length wall monitoring	10.9	—	—	—	X
Full-length drift	10.57	X	X	X	—
EUE connection inspection	10.63	X	X	X	—
UT critical area	10.10	—	—	—	X

^a Used, proprietary work-string tubing connections are inspected according to the manufacturer's inspection specifications; general guidelines are provided in Annex G.

^b Not required if performing full-length ultrasonic wall measurement.

Table B.16 — Pin-base marking system

Marking	Example meaning																
1) Tool joint manufacturer's symbol	ZZ indicates ZZ Company (fictional, for example only)																
2) Month welded: (1 to 12)	3 indicates March																
3) Year welded (last two digits of year)	02 indicates 2002																
4) Pipe manufacturer's symbol (See Table B.17)	N indicates United States Steel Company																
5) Drill-pipe grade symbol	a																
6) Drill-pipe weight code	b																
<p>^a Drill pipe grade symbols are as follows:</p> <table border="1"> <thead> <tr> <th>Symbol</th> <th>Grade</th> <th>Symbol</th> <th>Grade</th> </tr> </thead> <tbody> <tr> <td>E</td> <td>E75</td> <td>S</td> <td>S135</td> </tr> <tr> <td>X</td> <td>X95</td> <td>Z</td> <td>Z-140</td> </tr> <tr> <td>G</td> <td>G105</td> <td>V</td> <td>V-150</td> </tr> </tbody> </table>		Symbol	Grade	Symbol	Grade	E	E75	S	S135	X	X95	Z	Z-140	G	G105	V	V-150
Symbol	Grade	Symbol	Grade														
E	E75	S	S135														
X	X95	Z	Z-140														
G	G105	V	V-150														
<p>^b See Table C.4 (Table D.4), column 3, for weight codes.</p>																	

Table B.17 — Pipe manufacturer and processor symbols

Pipe manufacturers (pipe mills or processors)			
Active		Inactive	
Mill	Symbol	Mill	Symbol
Algoma	X	Armco	A
British Steel	—	American Seamless	AI
Seamless Tubes LTD	B	B&W	W
Dalmine	D	CF&I	C
Kawasaki	H	J&L	J
Nippon	I	Lone Star	L
NKK	K	Mannesmann	M
Reynolds Aluminium	RA	Ohio	O
Sumitomo	S	Republic	R
Siderca	SD	TI	Z
Tamsa	T	Tubemuse	TU
US Steel	N	Vallourec	V
Vallourec & Mannesmann	VM	Voest	VA
Used	U	Wheeling Pittsburgh	P
		Youngstown	Y
Active		Inactive	
Processor	Symbol	Processor	Symbol
Grant Prideco	GP	Grant TFW	TFW
Omsco	OMS	Prideco	PI
Texas Steel Conversion	TSC		

Table B.18 — Classification of used drill pipe

Classification condition	Premium class: two white bands	Class 2: one yellow band	Class 3: one orange band
Exterior conditions			
OD wear	Remaining wall not less than 80 %	Remaining wall not less than 70 %	Remaining wall less than 70 %
Dents and mashes	OD not less than 97 %	OD not less than 96 %	OD less than 96 %
Crushing and necking	OD not less than 97 %	OD not less than 96 %	OD less than 96 %
Slip area: cuts and gouges	Depth not more than 10 % of average adjacent wall ^a , and remaining wall not less than 80 %	Depth not more than 20 % of average adjacent wall ^a , and remaining wall not less than 80 % for transverse (70 % for longitudinal)	Depth more than 20 % of average adjacent wall ^a , or remaining wall less than 80 % for transverse (70 % for longitudinal)
Stretching	OD not less than 97 %	OD not less than 96 %	OD less than 96 %
String shot	OD not more than 103 %	OD not more than 104 %	OD more than 104 %
External corrosion	Remaining wall not less than 80 %	Remaining wall not less than 70 %	Remaining wall less than 70 %
Longitudinal cuts and gouges	Remaining wall not less than 80 %	Remaining wall not less than 70 %	Remaining wall less than 70 %
Transverse cuts and gouges	Remaining wall not less than 80 %	Remaining wall not less than 80 %	Remaining wall less than 80 %
Cracks	None ^b	None ^b	None ^b
Internal conditions			
Corrosion pitting	Remaining wall not less than 80 %	Remaining wall not less than 70 %	Remaining wall less than 70 %
Erosion and internal wall wear	Remaining wall not less than 80 %	Remaining wall not less than 70 %	Remaining wall less than 70 %
Cracks	None ^b	None ^b	None ^b
^a Average adjacent wall is determined by measuring the wall thickness on each side of the cut or gouge adjacent to deepest penetration. ^b In any classification where cracks or washouts appear, the pipe is identified with a red band and considered unfit for further drilling service.			

Table B.19 — Classification of used work-string tubing

Classification condition	Critical-service class: one white band	Premium class: two white bands	Class 2: one yellow band	Class 3: one orange band
Exterior conditions				
OD wear	Remaining wall not less than 87,5 %	Remaining wall not less than 80 %	Remaining wall not less than 70 %	Remaining wall less than 70 %
Dents and mashes	OD not less than 98 %	OD not less than 97 %	OD not less than 96 %	OD less than 96 %
Crushing and necking	OD not less than 98 %	OD not less than 97 %	OD not less than 96 %	OD less than 96 %
Slip area: cuts and gouges	Depth not more than 10 % of average adjacent wall ^a , and remaining wall not less than 87,5 %	Depth not more than 10 % of average adjacent wall ^a , and remaining wall not less than 80 %	Depth not more than 20 % of average adjacent wall ^a , and remaining wall not less than 80 % for transverse (70 % for longitudinal)	Depth more than 20 % of average adjacent wall ^a , or remaining wall less than 80 % for transverse (70 % for longitudinal)
Stretching	OD not less than 98 %	OD not less than 97 %	OD not less than 96 %	OD less than 96 %
String shot	OD not more than 102 %	OD not more than 103 %	OD not more than 104 %	OD more than 104 %
External corrosion	Remaining wall not less than 87,5 %	Remaining wall not less than 80 %	Remaining wall not less than 70 %	Remaining wall less than 70 %
Longitudinal cuts and gouges	Remaining wall not less than 87,5 %	Remaining wall not less than 80 %	Remaining wall not less than 70 %	Remaining wall less than 70 %
Transverse cuts and gouges	Remaining wall not less than 87,5 %	Remaining wall not less than 80 %	Remaining wall not less than 80 %	Remaining wall less than 80 %
Cracks	None ^b	None ^b	None ^b	None ^b
Internal conditions				
Corrosion pitting	Remaining wall not less than 87,5 % measured from base of deepest pit	Remaining wall not less than 80 % measured from base of deepest pit	Remaining wall not less than 70 % measured from base of deepest pit	Remaining wall less than 70 % measured from base of deepest pit
Erosion and internal wall wear	Remaining wall not less than 87,5 %	Remaining wall not less than 80 %	Remaining wall not less than 70 %	Remaining wall less than 70 %
Drift	Not less than 16 mm (0.031 in) smaller than specified bore ID	Not less than 16 mm (0.031 in) smaller than specified bore ID	Not less than 16 mm (0.031 in) smaller than specified bore ID	Less than 16 mm (0.031 in) smaller than specified bore ID
External upset				
Internal upset ^c				
Cracks	None ^b	None ^b	None ^b	None ^b
<p>^a Average adjacent wall is determined by measuring the wall thickness on each side of the cut or gouge adjacent to deepest penetration.</p> <p>^b In any classification where cracks or washouts appear, the pipe is identified with a red band and considered unfit for further drilling service.</p> <p>^c Applicable to internal upsets that have been bored.</p>				

Annex C (normative)

SI units

Table C.1 — Longitudinal magnetizing force for inside-diameter inspections

1	2	3	4	5
Label ^a	Outside diameter mm	Ampere turns		Minimum gauss in air at centre of coil
		203 mm ID coil	254 mm ID coil	
2 3/8	60,32	6 400	7 400	270
2 7/8	73,02	6 700	7 800	285
3 1/2	88,90	7 200	8 300	305
4	101,60	7 600	8 700	320
4 1/2	114,30	7 900	9 100	335
5	127,00	8 200	9 600	350
5 1/2	139,70	8 600	10 000	365
6 5/8	168,28	N/A	10 900	400

^a Labels are for information and assistance in ordering.

Table C.2 — Current requirements of internal-conductor magnetization

1	2	3	4
Number of pulses	Power supply type		Capacitor discharge units ^a Amps per kg/m
	Battery Amps per 25,4 mm	3-phase rectified AC Amps per 25,4 mm	
One	300	300	161
Two	N/A	N/A	121
Three	N/A	N/A	98

^a To determine the amperage required, multiply the value in column 4 by the linear mass, expressed in kilograms per metre, of the pipe.

**Table C.3 — Compensated thread lengths and contact-point size
for lead measurements parallel to taper cone**

Threads per 25,4 mm	Pitch	Taper mm/mm	Contact-point size for lead gauge $\pm 0,05$ mm	Thread length (parallel to thread axis) ^a mm	Compensated length (parallel to taper cone) ^a mm
5	5,080	1/6	2,92	25,4	25,488 0
5	5,080	1/4	2,92	25,4	25,597 7
4	6,350	1/8	3,67	25,4	25,449 6
4	6,350	1/6	3,67	25,4	25,488 0
4	6,350	1/4	3,67	25,4	25,597 7
3,5	7,257	1/6	5,13	50,8	50,976 1
3,5	7,257	1/4	5,13	50,8	51,195 3
3	8,467	5/48	5,99	25,4	25,434 4

^a Thread length is parallel to thread length. Compensated thread length is for measurements parallel to the taper cone.

Table C.4 — Dimensional values for classification of drill-pipe tubes

1	2	3	4	5	6	7	8	9	10	11	12
Label 1 ^a	Label 2 ^a	Weight code ^b	OD mm	Nominal linear mass kg/m	Nominal wall mm	Wall at percent remaining mm		OD at percent increase mm		OD at percent decrease mm	
						80 %	70 %	4 %	3 %	3 %	4 %
2 3/8	4,85	1	60,32	7,22	4,83	3,86	3,38	62,74	62,13	58,52	57,91
2 3/8	6,65	2	60,32	9,90	7,11	5,69	4,98	62,74	62,13	58,52	57,91
2 7/8	6,85	1	73,02	10,19	5,51	4,42	3,86	75,95	75,21	70,84	70,10
2 7/8	10,40	2	73,02	15,48	9,19	7,37	6,43	75,95	75,21	70,84	70,10
3 1/2	9,50	1	88,90	14,14	6,45	5,16	4,52	92,46	91,57	86,23	85,34
3 1/2	13,30	2	88,90	19,79	9,35	7,47	6,55	92,46	91,57	86,23	85,34
3 1/2	15,50	3	88,90	23,07	11,40	9,12	7,98	92,46	91,57	86,23	85,34
4	11,85	1	101,60	17,63	6,65	5,33	4,65	105,66	104,65	98,55	97,54
4	14,00	2	101,60	20,83	8,38	6,71	5,87	105,66	104,65	98,55	97,54
4	15,70	3	101,60	23,36	9,65	7,72	6,76	105,66	104,65	98,55	97,54
4 1/2	13,75	1	114,30	20,46	6,88	5,51	4,83	118,87	117,73	110,87	109,73
4 1/2	16,60	2	114,30	24,70	8,56	6,86	5,99	118,87	117,73	110,87	109,73
4 1/2	20,00	3	114,30	29,76	10,92	8,74	7,65	118,87	117,73	110,87	109,73
4 1/2	22,82	4	114,30	33,96	12,70	10,16	8,89	118,87	117,73	110,87	109,73
4 1/2	24,66	5	114,30	36,70	13,97	11,18	9,78	118,87	117,73	110,87	109,73
4 1/2	25,50	6	114,30	37,95	14,61	11,68	10,21	118,87	117,73	110,87	109,73
5	16,25	1	127,00	24,18	7,52	6,02	5,26	132,08	130,81	123,19	121,92
5	19,50	2	127,00	29,02	9,19	7,37	6,43	132,08	130,81	123,19	121,92
5	25,60	3	127,00	38,10	12,70	10,16	8,89	132,08	130,81	123,19	121,92
5 1/2	19,20	1	139,70	28,57	7,72	6,17	5,41	145,29	143,89	135,51	134,11
5 1/2	21,90	2	139,70	32,59	9,17	7,34	6,43	145,29	143,89	135,51	134,11
5 1/2	24,70	3	139,70	36,76	10,54	8,43	7,37	145,29	143,89	135,51	134,11
6 5/8	25,20	2	168,28	37,50	8,38	6,71	5,87	175,01	173,33	163,22	161,54
6 5/8	27,70	3	168,28	41,22	9,19	7,37	6,43	175,01	173,33	163,22	161,54

^a Labels are for information and assistance in ordering.

^b Weight code 2 designates standard mass for this pipe size.

Table C.5 — Dimensional values for classification of used work-string tubing

1	2	3	4	5	6	7	8	9	10	11	12	13	14
Label 1 ^a	Label 2 ^a	OD mm	Nominal linear mass kg/m	Nominal wall mm	Wall at percent remaining mm			Maximum OD at percent increase mm			Maximum OD at percent decrease mm		
					87,5 %	80 %	70 %	4 %	3 %	2 %	2 %	3 %	4 %
1,050	1,20	26,67	1,79	2,87	2,51	2,30	2,01	27,74	27,47	27,20	26,14	25,87	25,60
1,050	1,50	26,67	2,23	3,91	3,42	3,13	2,74	27,74	27,47	27,20	26,14	25,87	25,60
1,315	1,80	33,40	2,68	3,38	2,96	2,70	2,37	37,74	34,40	34,07	32,73	32,39	32,06
1,315	2,25	33,40	3,35	4,55	3,98	3,64	3,18	37,74	34,40	34,07	32,73	32,39	32,06
1,660	2,40	42,16	3,57	3,56	3,12	2,85	2,49	43,85	43,43	43,00	41,32	40,90	40,47
1,660	3,02	42,16	4,49	4,85	4,24	3,88	3,40	43,85	43,43	43,00	41,32	40,90	40,47
1,660	3,24	42,16	4,82	5,03	4,40	4,02	3,52	43,85	43,43	43,00	41,32	40,90	40,47
1,900	2,90	48,26	4,32	3,68	3,22	2,94	2,58	50,19	49,71	49,23	47,29	46,81	46,33
1,900	3,64	48,26	5,42	5,08	4,44	4,06	3,56	50,19	49,71	49,23	47,29	46,81	46,33
1,900	4,19	48,26	6,24	5,56	4,86	4,45	3,89	50,19	49,71	49,23	47,29	46,81	46,33
2,063	3,25	52,40	4,84	3,96	3,46	3,17	2,77	54,47	53,97	53,49	51,35	50,83	50,30
2,063	4,50	52,40	6,70	5,72	5,00	4,58	4,00	54,47	53,97	53,49	51,35	50,83	50,30
2 3/8	4,70	60,32	6,99	4,83	4,23	3,86	3,38	62,73	62,13	61,63	59,11	58,51	57,91
2 3/8	5,30	60,32	7,89	5,54	4,85	4,43	3,88	62,73	62,13	61,63	59,11	58,51	57,91
2 3/8	5,95	60,32	8,86	6,45	5,64	5,16	4,52	75,49	75,21	74,48	71,56	70,83	70,01
2 3/8	7,70	60,32	11,46	8,53	7,46	6,82	5,97	75,49	75,21	74,48	71,56	70,83	70,01
2 7/8	6,50	73,02	9,67	5,51	4,82	4,41	3,86	75,49	75,21	74,48	71,56	70,83	70,01
2 7/8	7,90	73,02	11,76	7,01	6,13	5,61	4,91	75,94	75,21	74,48	71,56	70,83	70,01
2 7/8	8,70	73,02	12,95	7,82	6,84	6,26	5,47	75,94	75,21	74,48	71,56	70,83	70,01
2 7/8	9,50	73,02	14,14	8,64	7,56	6,91	6,05	75,49	75,21	74,48	71,56	70,83	70,01
2 7/8	10,70	73,02	15,92	9,96	8,71	7,97	6,97	75,49	75,21	74,48	71,56	70,83	70,01
2 7/8	11,00	73,02	16,37	10,29	9,00	8,23	7,20	75,49	75,21	74,48	71,56	70,83	70,01
3 1/2	9,30	88,90	13,84	6,45	5,64	5,16	4,52	92,46	91,57	90,68	87,12	86,23	85,34
3 1/2	12,80	88,90	19,05	9,35	8,18	7,47	6,54	92,46	91,57	90,68	87,12	86,23	85,34
3 1/2	12,95	88,90	19,27	9,52	8,33	7,62	6,66	92,46	91,57	90,68	87,12	86,23	85,34
3 1/2	15,80	88,90	23,51	12,09	10,58	9,67	8,46	92,46	91,57	90,68	87,12	86,23	85,34
3 1/2	16,70	88,90	24,85	12,95	11,33	10,36	9,06	92,46	91,57	90,68	87,12	86,23	85,34
4 1/2	15,50	114,30	23,07	8,56	7,49	6,86	5,99	118,87	117,73	112,00	116,59	110,87	109,73
4 1/2	19,20	114,30	29,76	10,92	9,56	8,74	7,64	118,87	117,73	112,00	116,59	110,87	109,73

^a Labels are for information and assistance in ordering.

Table C.6 — Used tool-joint criteria

1	2	3	4	5	6	7	8	9	10	11	12
Pipe data					Premium class			Class 2			
Label 1 ^a	Label 2 ^a	New pipe OD	Nominal linear mass	Pipe grade	Tool-joint connection label ^a	Minimum OD tool joint	Maximum ID tool joint	Minimum box shoulder width eccentric wear	Minimum OD tool joint	Maximum ID tool joint	Minimum box shoulder width eccentric wear
		mm	kg/m			D_{tj} mm	d_{tj} mm	S_w mm	D_{tj} mm	d_{tj} mm	S_w mm
2 3/8	4,85	60,33	7,22	E75	NC26	79,38	50,01	1,19	78,58	52,39	0,79
					WO	77,79	53,98	1,59	76,99	54,77	1,19
					2 3/8 OHLW	76,20	53,18	1,59	75,41	54,77	1,19
					2 3/8 SL-H90	75,41	55,56	1,59	74,61	56,36	1,19
2 3/8	6,65	60,33	9,90	E75	2 3/8 PAC	70,64	34,93	3,57	69,06	40,48	2,78
					NC26	80,96	53,18	1,98	80,17	54,77	1,59
					2 3/8 SL-H90	76,99	53,18	2,38	75,41	54,77	1,59
					2 3/8 OHSW	77,79	52,39	2,38	76,99	53,98	1,98
				X95	NC26	82,55	50,80	2,78	81,76	53,18	2,38
				G105	NC26	83,34	49,21	3,18	82,55	51,59	2,78
2 7/8	6,85	73,03	10,19	E75	NC31	93,66	64,29	1,98	92,87	68,26	1,59
					2 7/8 WO	92,08	65,88	1,98	91,28	67,47	1,59
					2 7/8 OHLW	88,90	61,91	2,78	87,31	63,50	1,98
					2 7/8 SL-H90	88,90	65,88	2,38	87,31	66,68	1,59
2 7/8	10,40	73,03	15,48	E75	NC31	96,84	63,50	3,57	95,25	65,88	2,78
					2 7/8 XH	94,46	61,12	3,57	92,87	63,50	2,78
					NC26	85,73	43,66	4,37	84,93	46,83	3,97
					2 7/8 OHSW	91,28	57,94	3,97	90,49	60,33	2,78
					2 7/8 SL-H90	91,28	62,71	3,57	89,69	64,29	2,78
					2 7/8 PAC	79,38	30,96	5,95	79,38	35,72	5,95
				X95	NC31	99,22	58,74	4,76	97,63	61,91	3,97
					2 7/8 SL-H90	93,66	58,74	4,76	92,08	61,12	3,97
				G105	NC31	100,01	57,15	5,16	98,43	60,33	4,37
				S135	NC31	103,19	51,59	6,75	101,60	71,44	5,95
3 1/2	9,50	8,90	14,14	E75	NC38	111,92	80,96	3,18	110,33	57,15	2,38
					3 1/2 OHLW	108,74	78,58	3,18	107,95	80,17	2,78
					3 1/2 SL-H90	106,36	80,17	2,78	105,57	80,96	2,38

Table C.6 (continued)

1	2	3	4	5	6	7	8	9	10	11	12
Pipe data					Premium class			Class 2			
Label 1 ^a	Label 2 ^a	New pipe OD	Nominal linear mass	Pipe grade	Tool-joint connection label ^a	Minimum OD tool joint	Maximum ID tool joint	Minimum box shoulder width eccentric wear	Minimum OD tool joint	Maximum ID tool joint	Minimum box shoulder width eccentric wear
		mm	kg/m			D_{tj} mm	d_{tj} mm	S_w mm	D_{tj} mm	d_{tj} mm	S_w mm
3 1/2	13,30	88,90	19,79	E75	NC38	114,30	77,79	4,37	112,71	79,38	3,57
					NC31	101,60	53,98	5,95	100,01	57,94	5,16
					3 1/2 OHSW	111,92	74,61	4,76	110,33	77,79	3,97
					3 1/2 H90	115,09	84,14	3,18	114,30	85,73	2,78
				X95	NC38	116,68	73,03	5,56	115,09	76,20	4,76
					3 1/2 SL-H90	111,13	73,03	5,16	109,54	75,41	4,37
					3 1/2 H90	117,48	80,17	4,37	115,89	82,55	3,57
				G105	NC38	118,27	70,64	6,35	116,68	73,03	5,56
				S135	NC40	127,00	73,82	7,14	124,62	77,79	5,95
					NC38	122,24	64,29	8,33	119,86	73,82	7,14
3 1/2	15,50	88,90	23,07	E75	NC38	115,09	75,41	4,76	113,51	78,58	3,97
				X95	NC38	118,27	70,64	6,35	116,68	73,82	5,56
				G105	NC38	119,86	67,47	7,14	117,48	71,44	5,95
				S135	NC38	124,62	59,53	7,14	121,44	65,88	7,94
				G105	NC40	125,41	77,79	6,35	123,03	80,96	5,16
				S135	NC40	129,38	71,44	8,33	126,21	75,41	6,75
4	11,85	101,60	17,63	E75	NC46	132,56	102,39	2,78	130,97	103,98	1,98
					4 WO	132,56	102,39	2,78	130,97	103,98	1,98
4	11,85	101,80	17,63	E75	4 OHLW	127,00	96,04	3,57	125,41	97,63	2,78
					4 H90	123,83	94,46	2,78	123,03	96,04	2,38
4	14,00	101,60	20,83	E75	NC40	122,24	82,55	4,76	120,65	84,93	3,97
					NC46	134,14	100,01	3,57	132,56	102,39	2,78
					4 SH	112,71	65,88	5,95	111,13	69,06	5,16
					4 OHSW	128,59	93,66	4,37	127,00	96,04	3,57
					4 H90	125,41	92,87	3,57	123,83	94,46	2,78
				X95	NC40	125,41	77,79	6,35	123,03	80,96	5,16
					NC46	136,53	96,84	4,76	134,94	100,01	3,97
					4 H90	127,79	88,90	4,76	126,21	91,28	3,97
				G105	NC40	127,00	74,61	7,14	124,62	78,58	5,95
					NC46	138,11	95,25	5,56	135,73	97,63	4,37
					4 H90	129,38	87,31	5,56	127,79	88,11	4,76
				S135	NC46	141,29	88,90	7,14	139,70	92,87	6,35

Table C.6 (continued)

1	2	3	4	5	6	7	8	9	10	11	12
Pipe data					Premium class			Class 2			
Label 1 ^a	Label 2 ^a	New pipe OD	Nominal linear mass	Pipe grade	Tool-joint connection label ^a	Minimum OD tool joint	Maximum ID tool joint	Minimum box shoulder width eccentric wear	Minimum OD tool joint	Maximum ID tool joint	Minimum box shoulder width eccentric wear
		mm	kg/m			D_{tj} mm	d_{tj} mm	S_w mm	D_{tj} mm	d_{tj} mm	S_w mm
4	15,70	101,60	23,36	E75	NC40	123,83	79,38	5,56	121,44	83,34	4,37
					NC46	134,94	99,22	3,97	133,35	100,81	3,18
					4 H90	126,21	91,28	3,97	124,62	92,87	3,18
				X95	NC40	127,00	75,41	7,14	124,62	78,58	5,95
					NC46	138,11	95,25	5,56	135,73	97,63	4,37
					4 H90	129,38	87,31	5,56	127,79	89,69	4,76
				G105	NC46	138,91	92,87	5,95	137,32	96,04	5,16
					4 H90	130,97	84,93	6,35	128,59	88,11	5,16
				S135	NC46	143,67	86,52	8,33	140,49	90,49	6,75
4 1/2	16,60	114,30	24,70	E75	4 1/2 FH	136,53	92,08	5,16	134,14	94,46	3,97
					NC46	137,32	96,04	5,16	135,73	98,43	4,37
					4 1/2 OHSW	138,11	100,01	5,16	136,53	102,39	4,37
					NC50	145,26	109,54	3,97	144,46	111,92	3,57
					4 1/2 H-90	135,73	99,22	4,76	134,14	101,60	3,97
				X95	4 1/2 FH	139,70	86,52	6,75	137,32	90,49	5,56
					NC46	140,49	91,28	6,75	138,11	94,46	5,56
					NC50	148,43	105,57	5,56	146,84	107,95	4,76
					4 1/2 H-90	138,91	95,25	6,35	136,53	97,63	5,16
				G105	4 1/2 FH	141,29	92,87	7,54	138,91	96,04	6,35
					NC46	142,08	88,90	7,54	139,70	92,08	6,35
					NC50	150,02	103,19	6,35	147,64	106,36	5,16
					4 1/2 H-90	139,70	92,87	6,75	138,11	96,04	5,95
				S135	NC46	146,84	80,17	9,92	143,67	85,73	8,33
					NC50	153,99	96,84	8,33	151,61	100,81	7,14
4 1/2	20,00	114,30	29,76	E75	4 1/2 FH	138,91	88,90	6,35	136,53	92,08	5,16
					NC46	139,70	92,08	6,35	137,32	95,25	5,16
					NC50	147,64	106,36	5,16	146,05	109,54	4,76
					4 1/2 H-90	137,32	96,04	5,56	135,73	98,43	4,76
				X95	4 1/2 FH	142,88	81,76	8,33	140,49	85,73	7,14
					NC46	143,67	86,52	8,33	141,29	90,49	7,14
					NC50	150,81	101,60	6,75	149,23	104,78	5,95

Table C.6 (continued)

1	2	3	4	5	6	7	8	9	10	11	12
Pipe data					Premium class			Class 2			
Label 1 ^a	Label 2 ^a	New pipe OD	Nominal linear mass	Pipe grade	Tool-joint connection label ^a	Minimum OD tool joint	Maximum ID tool joint	Minimum box shoulder width eccentric wear	Minimum OD tool joint	Maximum ID tool joint	Minimum box shoulder width eccentric wear
		mm	kg/m			D_{tj} mm	d_{tj} mm	S_w mm	D_{tj} mm	d_{tj} mm	S_w mm
4 1/2	20,00	114,30	29,76	X95	4 1/2 H-90	141,29	90,49	7,54	138,91	94,46	6,35
				G105	NC46	145,26	82,55	9,13	142,88	88,11	7,94
					NC50	153,19	99,22	7,94	150,02	102,39	6,35
				S135	NC50	157,96	91,28	10,32	154,78	96,04	8,73
5	19,50	127,00	29,02	E75	NC50	149,23	103,98	5,95	147,64	107,16	5,16
				X95	NC50	153,19	98,43	7,94	150,81	101,60	6,75
					5 H-90	148,43	97,63	7,54	146,05	92,87	6,35
				G105	NC50	154,78	96,04	8,73	152,40	100,01	7,54
					5 H-90	150,02	95,25	8,33	147,64	98,43	7,14
				S135	NC50	160,34	86,52	11,51	157,16	92,08	9,92
					5 1/2 FH	171,45	107,95	9,53	168,28	111,92	7,94
				5	25,60	127,00	38,10	E75	NC50	153,19	99,22
5 1/2 FH	165,10	117,48	6,35						162,72	120,65	5,16
X95	NC50	157,96	90,49					10,32	154,78	96,04	8,73
	5 1/2 FH	169,07	111,13					8,33	166,69	115,09	7,14
G105	NC50	159,54	87,31					11,11	156,37	92,87	9,53
	5 1/2 FH	170,66	108,74					9,13	168,28	112,71	7,94
S135	5 1/2 FH	176,21	99,22					11,91	173,04	104,78	10,32
5 1/2	21,90	139,70	32,59					E75	5 1/2 FH	164,31	117,48
				X95	5 1/2 FH	168,28	110,33	7,94	165,89	115,09	6,75
					5 1/2 H-90	157,16	100,01	8,33	154,78	105,57	7,14
				G105	5 1/2 FH	170,66	108,74	9,13	167,48	112,71	7,54
				S135	5 1/2 FH	176,21	100,01	11,91	173,04	105,57	10,32
5 1/2	24,70	139,70	36,76	E75	5 1/2 FH	166,69	115,09	7,14	164,31	119,06	5,95
				X95	5 1/2 FH	170,66	108,74	9,13	167,48	112,71	7,54
				G105	5 1/2 FH	172,24	105,57	9,92	169,86	110,33	8,73
				S135	5 1/2 FH	178,59	94,46	13,10	174,63	101,60	11,11

Table C.6 (continued)

1	2	3	4	5	6	7	8	9	10	11	12
Pipe data						Premium class			Class 2		
Label 1 ^a	Label 2 ^a	New pipe OD	Nominal linear mass	Pipe grade	Tool-joint connection label ^a	Minimum OD tool joint	Maximum ID tool joint	Minimum box shoulder width eccentric wear	Minimum OD tool joint	Maximum ID tool joint	Minimum box shoulder width eccentric wear
		mm	kg/m			D_{tj} mm	d_{tj} mm	S_w mm	D_{tj} mm	d_{tj} mm	S_w mm
6 5/8	25,20	168,28	37,50	E75	6 5/8 FH	188,91	138,91	6,35	187,33	141,29	5,56
				X95	6 5/8 FH	193,68	131,76	8,73	190,50	136,53	7,14
				G105	6 5/8 FH	195,26	129,38	15,88	192,88	134,14	8,33
				S135	6 5/8 FH	200,82	119,06	12,30	197,64	125,41	10,72
6 5/8	27,70	168,28	41,22	E75	6 5/8 FH	190,50	136,53	7,14	188,12	139,70	5,95
				X95	6 5/8 FH	195,26	129,38	9,53	192,09	134,14	7,94
				G105	6 5/8 FH	196,85	125,41	10,32	194,47	130,18	9,13
				S135	6 5/8 FH	203,20	115,09	13,49	199,23	121,44	11,51

^a Labels are for information and assistance in ordering.

Table C.7 — Tool-joint-connection dimensional requirements

Dimensions in millimetres

1	2	3	4	5	6	7	8
Label ^a rotary-shouldered connection	Counter-bore diameter Q_c max.	Counter-bore length L_{qc} min.	Length pin L_{PC} min.	Length pin L_{PC} max.	Length pin base L_{pb} max.	Length box threads L_{BT} min.	Box depth L_{BC} min.
NC23	68,26	14,29	73,02	77,79	14,29	77,79	90,49
NC26	76,20	14,29	73,02	77,79	14,29	77,79	90,49
NC31	89,30	14,29	85,72	90,49	14,29	90,49	103,19
NC35	98,42	14,29	92,08	96,84	14,29	96,84	109,54
NC38	105,17	14,29	98,42	103,19	14,29	103,19	115,89
NC40	111,92	14,29	111,12	115,89	14,29	115,89	128,59
NC44	120,65	14,29	111,12	115,89	14,29	115,89	128,59
NC46	126,21	14,29	111,12	115,89	14,29	115,89	128,59
NC50	136,52	14,29	111,12	115,89	14,29	115,89	128,59
NC56	152,40	14,29	123,82	128,59	14,29	128,59	141,29
NC61	166,69	14,29	136,52	141,29	14,29	141,29	153,99
NC70	188,91	14,29	149,22	153,99	14,29	153,99	166,69
NC77	206,38	14,29	161,92	166,69	14,29	166,69	179,39
2 3/8 SH	65,09	14,29	69,85	74,61	14,29	77,79	90,49
2 7/8 SH	76,20	14,29	73,02	77,79	14,29	77,79	90,49
3 1/2 SH	89,30	14,29	85,72	90,49	14,29	90,49	103,19
4 SH	100,01	14,29	85,72	90,49	14,29	90,49	115,89
4 1/2 SH	105,17	14,29	98,42	103,19	14,29	115,89	127,00
2 3/8 PAC	62,71	7,94	57,15	61,91	7,94	61,91	74,61
2 7/8 PAC	67,07	7,94	57,15	61,91	7,94	61,91	74,61
2 3/8 SLH-90	71,83	14,29	69,85	73,02	6,35	74,61	87,31
2 7/8 SLH-90	83,74	14,29	73,02	76,20	6,35	77,79	90,49
2 3/8 OH	72,63	14,29	57,15	61,91	7,94	61,91	74,61
2 7/8 OH	82,95	14,29	69,85	74,61	7,94	74,61	84,14
2 7/8 XH	86,92	14,29	98,42	103,19	14,29	103,19	115,89
3 1/2 XH	100,01	14,29	85,72	90,49	14,29	90,49	103,19
4 1/2 FH	125,41	14,29	98,42	103,19	14,29	103,19	141,29
5 1/2 FH	151,61	14,29	123,82	128,59	14,29	128,59	141,29
6 5/8 FH	175,42	14,29	123,82	128,59	14,29	128,59	141,29
2 3/8 IF	76,20	14,29	73,02	77,79	14,29	77,79	90,49
2 7/8 IF	89,30	14,29	85,72	90,49	14,29	90,49	103,19
3 1/2 IF	105,17	14,29	98,42	103,19	14,29	103,19	115,89
5 1/2 IF	165,50	14,29	123,82	128,59	14,29	128,59	141,29
6 5/8 IF	192,48	14,29	123,82	128,59	14,29	128,59	141,29
3 1/2 H-90	107,95	14,29	98,42	103,19	11,11	103,19	115,89
4 H-90	117,48	14,29	104,78	109,54	11,11	109,54	122,24
4 1/2 H-90	125,81	14,29	111,12	115,89	11,11	115,89	128,59
5 H-90	132,95	14,29	117,48	122,24	11,11	122,24	134,94
5 1/2 H-90	139,70	14,29	117,48	122,24	11,11	122,24	134,94
6 5/8 H-90	155,58	14,29	123,82	128,59	11,11	128,59	141,29

NOTE See Figures 9 and 10.

^a Labels are for information and assistance in ordering.

Table C.8 — Used tool-joint bevel diameters ^a

Dimensions in millimetres

1	2	3	4	5	6
Label ^b rotary-shouldered connection	Label ^b interchangeable rotary-shouldered connections		Used tool-joint OD range ^c	Bevel diameter D_F minimum ^c	Bevel diameter D_F maximum ^d
NC26	2 3/8 IF	2 7/8 SH	82,95 to 85,72	82,55	86,52
NC31	2 7/8 IF	3 1/2 SH	100,41 to 111,12	100,01	103,98
NC38	3 1/2 IF	—	117,08 to 127,00	115,89	119,86
NC40	4 FH	—	127,40 to 139,70	127,00	130,97
NC46	4 IF	4 1/2 XH	145,26 to 158,75	144,86	148,83
NC50	4 1/2 IF	5 XH	153,99 to 168,28	153,59	157,56
NC56	—	—	171,05 to 177,80	170,66	174,62
3 1/2 FH	—	—	113,90 to 117,48	113,51	117,48
4 FH	—	—	127,40 to 139,70	127,00	130,97
4 1/2 FH	—	—	145,26 to 158,75	144,86	148,83
5 1/2 FH	—	—	170,66 to 184,15	170,26	174,23
5 1/2 FH	—	—	180,18 to 190,50	179,78	183,75
6 5/8 FH	—	—	195,66 to 215,90	195,26	199,23
4 H-90	—	—	133,75 to 139,70	133,35	137,32
4 1/2 H-90	—	—	144,86 to 152,40	144,86	148,83
2 7/8 SH	NC26	2 3/8 IF	82,95 to 85,72	82,55	86,52
3 1/2 SH	NC31	2 7/8 IF	100,41 to 111,12	100,01	103,98
4 SH	—	—	111,52 to 117,48	109,93	113,90
3 1/2 XH	—	—	115,09 to 120,65	114,70	118,67
4 1/2 XH	NC46	4 IF	145,26 to 158,75	144,86	148,83
5 XH	NC50	4 1/2 IF	153,99 to 168,28	153,59	157,56

NOTE See Figures 2 and 10.

^a Tool-joint bevel diameters apply to drill-pipe tool joints, lower kelly connections, kelly saver subs, HWDP and all connections that make up to these connections.

^b Labels are for information and assistance in ordering.

^c When the OD becomes smaller than the minimum bevel diameter, a reduced bevel of 0,08 mm × 45° shall be ground or machined on the full circumference of the sealing face of the pin or box. The reduced bevel shall not be cause for rejection.

^d The maximum bevel diameter is for connections that have been re-faced with portable refacing equipment at the rig or warehouse. It is not for connections re-machined in a machine shop.

Table C.9 — Drill-collar connection dimensions (without stress-relief features)

Dimensions in millimetres

1	2	3	4	5	6	7	8
Label ^a rotary-shouldered connection	Counterbore diameter Q_C or D_{LTorq} maximum	Counter-bore length L_{qc} minimum	Length pin L_{PC} minimum	Length pin L_{PC} maximum	Length pin base L_{pb} maximum	Length box threads L_{BT} minimum	Box depth L_{BC} minimum
NC23	68,26	14,29	73,02	77,79	14,29	77,79	90,49
NC26	76,20	14,29	73,02	77,79	14,29	77,79	90,49
NC31	89,30	14,29	85,72	90,49	14,29	90,49	103,19
NC35	98,42	14,29	92,08	96,84	14,29	96,84	109,54
NC38	105,17	14,29	98,42	103,19	14,29	103,19	115,89
NC40	111,92	14,29	111,12	115,89	14,29	115,89	128,59
NC44	120,65	14,29	111,12	115,89	14,29	115,89	128,59
NC46	126,21	14,29	111,12	115,89	14,29	115,89	128,59
NC50	136,52	14,29	111,12	115,89	14,29	115,89	128,59
NC56	152,40	14,29	123,82	128,59	14,29	128,59	141,29
NC61	166,69	14,29	136,52	141,29	14,29	141,29	153,99
NC70	188,91	14,29	149,22	153,99	14,29	153,99	166,69
NC77	206,38	14,29	161,92	166,69	14,29	166,69	179,39
2 3/8 REG	69,85	14,29	73,03	77,79	14,29	77,79	90,49
2 7/8 REG	79,38	14,29	85,73	90,49	14,29	90,49	103,19
3 1/2 REG	92,08	14,29	92,08	96,84	14,29	96,84	109,54
4 1/2 REG	120,65	14,29	104,78	109,54	14,29	109,54	122,24
5 1/2 REG	143,27	14,29	117,48	122,24	14,29	122,24	134,94
6 5/8 REG	155,58	14,29	123,83	128,59	14,29	128,59	141,29
7 5/8 REG FF	181,77	14,29	130,18	134,94	14,29	134,94	147,64
7 5/8 REG LT	198,44	7,94	130,18	134,94	14,29	134,94	147,64
8 5/8 REG FF	205,98	14,29	133,35	138,11	14,29	138,11	150,81
8 5/8 REG LT	230,19	7,94	133,35	138,11	14,29	138,11	150,81
2 3/8 SH	65,09	14,29	73,02	77,79	14,29	77,79	90,49
2 7/8 SH	76,20	14,29	73,02	77,79	14,29	77,79	90,49
3 1/2 SH	89,30	14,29	85,72	90,49	14,29	90,49	103,19
4 SH	100,01	14,29	85,72	90,49	14,29	90,49	115,89
4 1/2 SH	105,17	14,29	98,42	103,19	14,29	103,19	115,89
2 3/8 PAC	62,71	7,94	57,15	61,91	7,94	61,91	74,61
2 7/8 PAC	67,07	7,94	57,15	61,91	7,94	61,91	74,61
3 1/2 PAC	80,57	7,94	79,38	84,14	7,94	84,14	96,84
2 3/8 SLH-90	71,83	14,29	69,85	73,02	6,35	74,61	87,31
2 7/8 SLH-90	83,74	14,29	73,02	76,20	6,35	77,79	90,49

Table C.9 (continued)

Dimensions in millimetres

1	2	3	4	5	6	7	8
Label ^a rotary-shouldered connection	Counterbore diameter Q_c or $D_{L\text{Torq}}$ maximum	Counter-bore length L_{qc} minimum	Length pin L_{PC} minimum	Length pin L_{PC} maximum	Length pin base L_{pb} maximum	Length box threads L_{BT} minimum	Box depth L_{BC} minimum
2 3/8 OH	73,02	14,29	57,15	61,91	7,94	61,91	74,61
2 7/8 OH	82,55	14,29	69,85	74,61	7,94	74,61	84,14
2 7/8 XH	86,92	14,29	98,42	103,19	14,29	103,19	115,89
3 1/2 XH	100,01	14,29	85,72	90,49	14,29	90,49	103,19
3 1/2 FH	104,38	14,29	92,08	96,84	14,29	96,84	109,54
4 FH	111,92	14,29	111,12	115,89	14,29	115,89	128,59
4 1/2 FH	125,41	14,29	98,42	103,19	14,29	103,19	141,29
5 1/2 FH	139,30	14,29	123,82	128,59	14,29	128,59	141,29
6 5/8 FH	175,42	14,29	123,82	128,59	14,29	128,59	141,29
2 3/8 IF	76,20	14,29	73,02	77,79	14,29	77,79	90,49
2 7/8 IF	89,30	14,29	85,72	90,49	14,29	90,49	103,19
3 1/2 IF	105,17	14,29	98,42	103,19	14,29	103,19	115,89
5 1/2 IF	165,50	14,29	123,82	128,59	14,29	128,59	141,29
6 5/8 IF	192,48	14,29	123,82	128,59	14,29	128,59	141,29
3 1/2 H-90	107,95	14,29	98,42	103,19	11,11	103,19	115,89
4 H-90	117,48	14,29	104,78	109,54	11,11	109,54	122,24
4 1/2 H-90	125,81	14,29	111,12	115,89	11,11	115,89	128,59
5 H-90	132,95	14,29	117,48	122,24	11,11	122,24	134,94
5 1/2 H-90	139,70	14,29	117,48	122,24	11,11	122,24	134,94
6 5/8 H-90	155,58	14,29	123,82	128,59	11,11	128,59	141,29
7 H-90 FF	168,28	14,29	136,53	141,29	11,11	141,29	153,99
7 H-90 LT	182,56	8,73	136,53	141,29	11,11	141,29	153,99
7 5/8 H-90 FF	190,90	14,29	152,40	157,16	11,11	157,16	169,86
7 5/8 H-90 LT	204,79	8,73	152,40	157,16	11,11	157,16	169,86
8 5/8 H-90 FF	213,12	14,29	165,10	169,86	11,11	169,86	106,36
8 5/8 H-90 LT	239,71	8,73	165,10	169,86	11,11	169,86	106,36
NOTE See Figures 9, 10 and 11.							
^a Labels are for information and assistance in ordering.							

Table C.10 — Dimensional limits on used bottom-hole-assembly connections with stress-relief features ^a

Dimensions in millimetres

1	2	5	3	4	6	7	8	9	10
Label ^b rotary-shouldered connection	Counter-bore diameter Q_c or $D_{L\text{Torq}}$ maximum	Counter-bore length L_{qc} minimum	Length pin L_{PC} minimum	Length pin L_{PC} maximum	Pin relief groove dia. D_{RG} minimum	Pin relief groove dia. D_{RG} maximum	Box boreback cylinder dia. D_{cb} minimum	Box boreback cylinder dia. D_{cb} maximum	Box boreback thread vanish point L_x ref.
NC35	98,42	14,29	92,08	96,84	81,28	82,07	82,15	82,55	82,55
NC38	105,17	14,29	98,42	103,19	88,32	89,10	88,11	88,50	88,90
NC40	111,92	14,29	111,12	115,89	95,02	95,81	92,87	93,27	101,60
NC44	120,65	14,29	111,12	115,89	103,78	104,57	101,60	102,00	101,60
NC46	126,21	14,29	111,12	115,89	109,09	109,88	106,76	107,16	101,60
NC50	136,53	14,29	111,12	115,89	119,66	120,45	117,48	117,87	101,60
NC56	152,40	14,29	123,82	128,59	133,25	134,04	121,84	122,24	114,30
NC61	166,69	14,29	136,52	141,29	147,52	148,31	132,95	133,35	127,00
NC70	188,91	14,29	123,82	153,99	169,75	170,54	152,00	152,40	139,70
NC77	206,38	14,29	161,92	166,69	187,22	188,01	166,29	166,69	152,40
4 1/2 REG	120,65	14,29	104,78	109,54	101,14	101,93	94,46	94,85	95,25
5 1/2 REG	143,27	14,29	117,48	122,24	122,89	123,67	114,30	114,70	107,95
6 5/8 REG	155,58	14,29	123,82	128,59	136,80	137,59	134,14	134,54	114,30
7 5/8 REG FF	181,77	14,29	130,18	134,94	160,48	161,26	148,83	145,26	120,65
7 5/8 REG LT	198,44	7,94	130,18	134,94	160,48	161,26	148,83	145,26	114,30
8 5/8 REG FF	205,98	14,29	133,35	138,11	184,66	185,45	172,24	172,64	123,82
8 5/8 REG LT	230,19	7,94	133,35	138,11	184,66	185,45	172,24	172,64	123,82
4 1/2 SH	105,17	14,29	98,42	103,19	88,32	89,10	88,11	88,50	88,90
3 1/2 FH	104,38	14,29	92,08	96,84	86,12	86,92	81,76	82,15	82,55
4 FH	111,92	14,29	111,12	115,89	95,02	95,81	92,87	93,27	101,60
4 1/2 FH	125,41	14,29	98,42	103,19	105,38	106,17	100,41	100,81	88,90
5 1/2 FH	139,30	14,29	123,82	128,59	132,56	133,35	129,78	130,18	114,30
6 5/8 FH	175,42	14,29	123,82	128,59	155,97	156,77	153,59	153,99	114,30
3 1/2 IF	105,17	14,29	98,42	103,19	88,32	89,10	88,11	88,50	88,90
5 1/2 IF	177,01	14,29	123,82	128,59	148,83	149,62	144,46	144,86	114,30
6 5/8 IF	192,48	14,29	123,82	128,59	175,82	176,61	171,45	171,85	114,30
3 1/2 H-90	107,95	14,29	98,42	103,19	92,08	92,87	90,49	90,88	88,90
4 H-90	117,48	14,29	104,78	109,54	101,60	102,39	98,42	98,82	95,25
4 1/2 H-90	125,81	14,29	111,12	115,89	109,93	110,73	106,36	106,76	101,60
5 H-90	132,95	14,29	117,48	122,24	116,68	117,48	111,92	112,32	107,95
5 1/2 H-90	139,70	14,29	117,48	122,24	123,82	124,62	105,97	106,36	107,95
6 5/8 H-90	155,58	14,29	123,82	128,59	139,70	140,49	133,75	107,95	114,30
7 H-90 FF	168,28	14,29	136,52	141,29	152,40	153,19	133,75	107,95	127,00
7 H-90 LT	182,56	8,73	136,52	141,29	152,40	153,19	133,75	107,95	127,00
7 5/8 H-90 FF	190,90	14,29	152,40	157,16	174,62	175,42	152,40	152,80	142,88
7 5/8 H-90 LT	204,79	8,73	152,40	157,16	174,62	175,42	152,40	152,80	142,88
8 5/8 H-90 FF	213,12	14,29	165,10	169,86	196,85	197,64	171,45	171,85	155,58
8 5/8 H-90 LT	239,71	8,73	165,10	169,86	196,85	197,64	171,45	171,85	155,58

NOTE See Figures 9, 11, 12 and 13.

^a Bottom-hole-assembly connections include all connections between, but not including, the bit and the drill pipe.^b Labels are for information and assistance in ordering.

Table C.11 — Used drill-collar bevel diameters

Dimensions in millimetres

1	2	3	4	5	6
Label ^a rotary-shouldered connection	Label ^a interchangeable rotary-shouldered connections		Drill-collar outside-diameter range ^b	Bevel diameter D_F minimum	Bevel diameter D_F maximum ^c
NC23	—	—	79,38 to 82,55	75,80	79,77
NC26	3 3/8 IF	2 7/8 SH	85,72 to 91,68	82,55	86,52
			92,08 to 98,03	87,31	91,28
			98,42 to 101,60	92,08	96,04
NC31	2 7/8 IF		104,78 to 110,73	100,01	103,98
			111,12 to 117,48	104,78	108,74
NC35	—	—	120,65 to 126,60	114,30	118,27
NC38	3 1/2 IF	4 1/2 SH	120,65 to 126,60	115,89	119,86
			127,00 to 132,95	120,65	124,62
			133,35 to 139,30	125,41	103,98
NC40	4 FH	—	133,35 to 139,30	127,00	130,97
			139,70 to 145,65	131,76	135,73
			146,05 to 152,00	136,52	140,49
NC44	—	—	146,05 to 152,00	139,30	143,27
			152,40 to 158,35	144,07	148,03
			158,75 to 164,70	148,83	152,80
NC46	4 IF	4 1/2 XH	152,40 to 158,35	144,86	148,83
			158,75 to 161,53	149,62	153,59
			165,10 to 171,05	154,38	158,35
			171,45 to 177,40	159,15	163,12
NC50	4 1/2 IF	5 XH	155,58 to 161,53	153,59	157,56
			161,92 to 167,88	154,78	158,75
			168,28 to 174,23	159,54	163,51
			174,62 to 180,58	164,31	168,28
			180,98 to 186,93	169,07	173,04
NC56	—	—	190,50 to 196,45	180,18	184,15
			196,85 to 202,80	184,94	188,91
			203,20 to 209,15	189,71	193,68
NC 61	—	—	209,55 to 215,50	198,04	202,01
			215,90 to 221,85	202,80	206,77
			222,25 to 228,20	207,57	211,53
			228,60 to 234,55	212,33	216,30
NC 70	—	—	241,30 to 247,25	227,41	231,38
			247,65 to 253,60	232,17	235,74
			254,00 to 259,95	236,93	240,90
NC77	—	—	279,40 to 285,35	260,35	264,32
2 3/8 REG	—	—	82,55 to 85,33	76,20	80,17
			85,72 to 88,90	80,96	84,93

Table C.11 (continued)

Dimensions in millimetres

1	2	3	4	5	6
Label ^a rotary-shouldered connection	Label ^a interchangeable rotary-shouldered connections		Drill-collar outside-diameter range ^b	Bevel diameter D_F minimum	Bevel diameter D_F maximum ^c
2 7/8 REG	—	—	98,42 to 101,60	90,49	94,46
3 1/2 REG	—	—	107,95 to 126,21	103,19	107,16
			114,30 to 117,48	107,95	119,86
4 1/2 REG	—	—	142,88 to 145,65	134,14	138,11
			146,05 to 152,00	138,91	142,88
			152,40 to 155,58	143,67	147,64
5 1/2 REG	—	—	168,28 to 171,05	159,15	163,12
			171,45 to 177,40	163,91	167,88
			177,80 to 183,75	168,67	172,64
			184,15 to 202,41	173,43	177,40
			190,50 to 193,68	178,20	182,17
6 5/8 REG	—	—	190,50 to 196,45	180,98	184,94
			196,85 to 202,80	185,74	189,71
			203,20 to 209,15	190,50	193,68
			209,55 to 212,72	195,26	199,23
7 5/8 REG FF	—	—	219,08 to 225,03	209,15	213,12
			225,42 to 231,38	213,92	217,88
			231,78 to 237,73	218,68	222,65
			238,12 to 244,08	223,44	227,41
7 5/8 REG LT	—	—	244,48 to 254,00	234,55	238,52
8 5/8 REG FF	—	—	244,48 to 247,25	231,78	235,74
			247,65 to 253,60	236,54	240,51
			254,00 to 259,95	241,30	245,27
			260,35 to 266,30	246,06	250,03
			266,70 to 269,48	250,82	254,79
8 5/8 REG LT	—	—	269,88 to 282,58	266,30	270,27
3 1/2 FH	—	—	123,82 to 129,78	118,27	122,24
			130,18 to 136,13	123,03	127,00
4 1/2 FH	—	—	146,05 to 152,00	140,10	144,07
			152,40 to 158,35	144,86	148,83
			158,75 to 164,70	149,62	153,59
5 1/2 FH	—	—	174,62 to 177,40	165,50	169,47
			177,80 to 183,75	170,26	174,23
			184,15 to 190,10	175,02	178,99
			190,50 to 196,45	179,78	183,75
			196,85 to 202,80	184,55	188,52
			203,20 to 209,15	189,31	193,28

Table C.11 (continued)

Dimensions in millimetres

1	2	3	4	5	6
Label ^a rotary-shouldered connection	Label ^a interchangeable rotary-shouldered connections		Drill-collar outside-diameter range ^b	Bevel diameter D_F minimum	Bevel diameter D_F maximum ^c
6 5/8 FH	—	—	203,20 to 209,15	195,26	199,23
			209,55 to 215,50	200,02	203,99
			215,90 to 221,85	204,79	208,76
			222,25 to 228,20	209,55	213,52
			228,60 to 234,55	214,31	218,28
			234,95 to 241,30	219,08	223,04
2 3/8 SL H-90	—	—	82,55 to 85,72	78,98	82,95
2 7/8 SL H-90	—	—	104,78 to 107,55	98,03	102,00
			107,95 to 109,54	104,38	108,35
3 1/2 SL H-90	—	—	123,82 to 126,60	117,08	121,05
			127,00 to 130,18	123,43	127,40
3 1/2 H-90	—	—	127,00 to 132,95	121,84	125,81
			133,35 to 139,70	126,60	130,57
4 H-90	—	—	152,40 to 155,18	139,30	143,27
			155,58 to 158,75	145,65	149,62
4 1/2 H-90	—	—	152,40 to 158,35	145,65	149,62
			158,75 to 167,88	152,00	155,97
			168,28 to 171,45	158,35	162,32
5 H-90	—	—	165,10 to 171,05	155,18	159,15
			171,45 to 177,80	161,53	165,50
5 1/2 H-90	—	—	171,45 to 175,02	161,53	165,50
			174,62 to 190,50	167,88	171,85
6 5/8 H-90	—	—	193,68 to 196,45	183,75	187,72
			196,85 to 209,55	190,10	194,07
7 H-90	—	—	209,55 to 215,50	202,80	206,77
			215,90 to 219,08	209,15	213,12
7 H-90 LT	—	—	219,08 to 228,20	209,15	213,12
			228,60 to 231,78	218,68	222,65
7 5/8 H-90	—	—	241,30 max. OD ^b	234,55	238,52
7 5/8 H-90 LT	—	—	247,65 to 250,43	234,55	238,52
			250,82 to 260,35	244,08	248,05
8 5/8 H-90	—	—	266,70 to 269,88	253,60	257,57
8 5/8 H-90 LT	—	—	273,05 to 285,35	266,30	270,27
			285,75 to 292,10	272,65	276,62
2 3/8 PAC	—	—	69,85 to 75,80	68,26	72,23
			76,20 to 79,38	69,45	73,42
2 7/8 PAC	—	—	79,38 to 82,55	75,80	79,77
2 3/8 OH	—	—	77,79 to 80,96	75,80	79,77

Table C.11 (continued)

Dimensions in millimetres

1	2	3	4	5	6
Label ^a rotary-shouldered connection	Label ^a interchangeable rotary-shouldered connections		Drill-collar outside-diameter range ^b	Bevel diameter D_F minimum	Bevel diameter D_F maximum ^c
2 7/8 OH	—	—	95,25 to 101,20	91,28	95,25
			101,60 to 107,95	94,85	98,82
2 3/8 SH	—	—	79,38 to 80,96	75,01	78,98
3 1/2 SH	—	—	104,78 to 110,73	100,01	103,98
			111,12 to 114,30	104,78	108,74
4 SH	3 1/2 XH	—	120,65 to 126,60	114,70	118,67
			127,00 to 130,18	119,46	123,43
2 7/8 XH	3 1/2 DSL	—	104,78 to 110,73	97,23	101,20
			111,12 to 114,30	102,00	105,97
5 1/2 IF	—	—	190,50 to 193,28	180,98	184,94
			193,68 to 199,63	185,74	189,71
			200,02 to 205,98	190,50	194,47
			206,38 to 212,33	195,26	199,23
			212,72 to 217,49	200,02	203,99
			219,08 to 225,03	204,79	208,76
6 5/8 IF	—	—	225,42 to 228,60	209,55	213,52
			228,60 to 234,55	218,68	222,65
			234,95 to 253,21	223,44	227,41
			241,30 to 247,25	228,20	232,17
			247,65 to 253,60	232,97	236,93
			254,00 to 260,35	237,73	241,70

NOTE 1 See Figures 10 and 12.

NOTE 2 Drill-collar connections include all connections between, but not including, the bit, HWDP and/or the drill pipe.

^a Labels are for information and assistance in ordering.

^b Maximum OD for a connection label may be too large for that connection label. The user should check the connection bending-strength ratio and the connection torsional balance before accepting that OD.

^c Maximum bevel diameter is for connections that have been re-faced in the field. Bevels on newly machined connections shall be in accordance with ISO 10424-1.

Table C.12 — Bending-strength ratios for bottom-hole assemblies

Dimensions in millimetres

1	2	3	4	5	6	7
Connection label ^a	Inside diameter ^b	Outside diameter at bending-strength ratio ^c				
		1,90	2,25	2,50	2,75	3,20
NC23	31,75	73,82	76,99	78,58	80,96	84,14
	38,10	71,44	74,61	76,20	77,79	81,36
	44,45	68,26	70,25	71,83	73,42	75,80
NC26	38,10	84,14	87,31	89,69	92,08	95,65
	44,45	81,76	84,93	86,52	88,90	92,47
	50,80	77,79	80,17	82,55	84,14	86,92
NC31	38,10	102,39	106,36	109,54	111,92	117,08
	44,45	100,81	104,78	107,95	110,33	115,09
	50,80	99,22	103,19	105,57	107,95	112,32
NC35	38,10	114,30	119,06	122,24	125,41	130,97
	44,45	125,41	118,27	121,44	124,62	129,78
	50,80	111,92	116,68	119,86	123,03	127,79
	57,15	110,33	114,30	117,48	119,86	125,02
	63,50	106,36	110,33	113,51	115,89	120,25
NC38	38,10	123,83	129,38	132,56	136,53	142,08
	44,45	123,03	128,59	131,76	134,94	140,89
	50,80	122,24	127,00	130,18	134,14	139,70
	57,15	120,65	125,41	128,59	131,76	137,32
	63,50	118,27	122,24	125,41	128,59	133,75
NC40	50,80	130,97	136,53	140,49	143,67	150,02
	57,15	130,18	134,94	138,91	142,08	147,64
	63,50	127,79	132,56	136,53	139,70	146,05
	71,44	124,22	128,59	132,56	134,94	141,29
NC44	50,80	143,67	149,23	153,99	157,16	164,31
	57,15	142,88	148,43	153,19	156,37	163,51
	63,50	141,29	146,84	150,81	153,99	161,13
	71,44	139,70	143,67	147,64	150,81	157,16
NC46	50,80	151,61	157,16	161,93	165,89	173,04
	57,15	150,81	156,37	161,13	164,31	172,24
	63,50	149,23	154,78	159,54	162,72	170,66
	71,44	146,84	152,40	157,16	160,34	167,48
	76,20	145,26	150,02	154,78	157,96	164,31
	82,55	142,08	146,84	150,81	153,99	160,34
NC50	57,15	165,89	172,24	177,01	180,98	189,71
	63,50	164,31	170,66	176,21	180,18	188,12
	71,44	162,72	169,07	173,83	177,80	185,74
	76,20	161,93	167,48	172,24	176,21	184,15
	82,55	159,54	165,10	169,86	173,04	180,98
	88,90	156,37	161,93	165,89	169,86	176,21

Table C.12 (continued)

Dimensions in millimetres

1	2	3	4	5	6	7
Connection label ^a	Inside diameter ^b	Outside diameter at bending-strength ratio ^c				
		1,90	2,25	2,50	2,75	3,20
NC56	57,15	181,77	189,71	195,26	200,03	209,55
	63,50	180,98	188,91	194,47	199,23	208,76
	71,44	179,39	187,33	192,88	197,64	207,17
	76,20	178,59	185,74	192,09	196,06	205,58
	82,55	177,01	184,15	189,71	194,47	203,20
	88,90	174,63	181,77	187,33	191,29	200,03
NC61	63,50	200,03	208,76	215,11	220,66	230,98
	71,44	199,23	207,17	214,31	219,08	229,39
	76,20	198,44	206,38	213,52	218,28	228,60
	82,55	196,85	205,58	211,93	216,69	227,01
	88,90	195,26	203,20	209,55	215,11	224,63
NC70	63,50	229,39	239,71	247,65	253,21	265,11
	71,44	228,60	238,92	246,86	252,41	264,32
	76,20	228,60	238,92	246,06	252,41	263,53
	82,55	227,81	237,33	245,27	250,83	262,73
	88,90	226,22	236,54	243,68	250,03	261,14
	95,25	225,43	234,95	242,09	249,24	259,56
NC77	71,44	252,41	263,53	271,46	278,61	291,31
	76,20	251,62	263,53	271,46	278,61	290,51
	82,55	250,83	262,73	270,67	277,81	289,72
	88,90	250,03	261,94	269,88	276,23	288,93
	95,25	249,24	260,35	268,29	275,43	288,13
2 3/8 REG	31,75	72,23	75,41	77,79	79,38	83,34
	38,10	69,85	73,03	74,61	76,20	80,17
2 7/8 REG	31,75	84,93	88,11	91,28	93,66	98,43
	38,10	83,34	87,31	89,69	92,08	96,84
	44,45	80,96	84,14	87,31	88,90	93,66
3 1/2 REG	38,10	101,60	105,57	109,54	111,92	117,48
	44,45	100,01	103,98	107,95	110,33	115,09
	50,80	98,03	101,60	105,57	107,95	112,71
4 1/2 REG	50,80	138,91	145,26	150,02	153,19	160,34
	57,15	138,11	143,67	148,43	151,61	159,54
	63,50	136,53	142,08	146,84	150,02	157,16
5 1/2 REG	57,15	167,48	175,42	180,98	184,94	193,68
	63,50	166,69	173,83	179,39	183,36	192,09
	71,44	165,89	172,24	177,80	181,77	190,50
	76,20	164,31	170,66	176,21	180,18	188,12
	82,55	161,93	168,28	173,83	177,80	185,74
	88,90	158,75	165,10	169,86	173,83	182,56

Table C.12 (continued)

Dimensions in millimetres

1	2	3	4	5	6	7
Connection label ^a	Inside diameter ^b	Outside diameter at bending-strength ratio ^c				
		1,90	2,25	2,50	2,75	3,20
6 5/8 REG	63,50	188,91	196,85	202,41	207,17	216,69
	71,44	188,12	195,26	200,82	205,58	215,11
	76,20	187,33	194,47	200,03	204,79	213,52
	82,55	185,74	192,88	198,44	203,20	211,93
	88,90	184,15	190,50	196,06	201,61	208,76
7 5/8 REG	63,50	219,08	228,60	235,74	241,30	252,41
	71,44	218,28	227,81	234,16	240,51	250,83
	76,20	217,49	227,01	233,36	239,71	250,03
	82,55	216,69	225,43	232,57	238,92	249,24
	88,90	215,11	224,63	230,98	236,54	248,44
	95,25	213,52	223,04	229,39	234,95	245,27
8 5/8 REG	71,44	251,62	262,73	270,67	277,02	289,72
	76,20	250,83	261,94	269,88	276,23	288,93
	82,55	250,83	261,14	269,08	276,23	288,13
	88,90	250,03	260,35	268,29	274,64	287,34
	95,25	249,24	259,56	267,49	273,84	285,75
2 7/8 FH	38,10	106,36	111,13	114,30	117,48	123,03
	44,45	105,57	109,54	112,71	115,89	121,44
	50,80	103,19	107,95	111,13	113,51	119,06
3 1/2 FH	38,10	119,06	124,62	128,59	130,97	137,32
	44,45	118,27	123,03	127,00	130,18	136,53
	50,80	117,48	121,44	125,41	128,59	134,94
	57,15	115,09	119,86	123,83	126,21	131,76
	63,50	111,92	116,68	120,65	123,03	128,59
4 1/2 FH	50,80	146,05	151,61	157,16	160,34	168,28
	57,15	144,46	150,81	155,58	158,75	166,69
	63,50	143,67	149,23	153,99	157,16	164,31
	71,44	140,49	146,05	150,81	153,99	161,13
	76,20	138,51	143,67	148,43	151,61	158,75
	82,55	134,94	139,70	144,46	147,64	153,99
5 1/2 FH	57,15	184,15	191,29	196,85	201,61	210,34
	63,50	183,36	190,50	196,06	200,82	209,55
	71,44	181,77	188,91	194,47	199,23	207,96
	76,20	180,98	188,12	193,68	197,64	206,38
	82,55	179,39	187,33	192,09	196,85	203,99
	88,90	177,80	184,94	188,91	193,68	201,61

Table C.12 (continued)

Dimensions in millimetres

1	2	3	4	5	6	7
Connection label ^a	Inside diameter ^b	Outside diameter at bending-strength ratio ^c				
		1,90	2,25	2,50	2,75	3,20
6 5/8 FH	63,50	216,69	225,43	231,78	237,33	247,65
	71,44	215,90	224,63	230,98	236,54	246,86
	76,20	215,11	223,84	230,19	235,74	246,06
	82,55	214,31	222,25	229,39	234,16	244,48
	88,90	212,73	221,46	227,81	232,57	242,89
	95,25	211,14	219,08	225,43	230,98	240,51
3 1/2 H 90	50,80	127,79	132,56	136,53	139,70	146,05
	57,15	126,21	130,18	134,94	137,32	143,67
	63,50	123,83	127,79	131,76	134,94	140,49
4 H 90	50,80	140,49	146,05	150,81	153,99	161,13
	57,15	139,70	144,46	149,23	152,40	159,54
	63,50	138,11	142,88	147,64	150,81	157,16
	71,44	134,94	139,70	144,46	147,64	153,19
4 1/2 H 90	50,80	152,40	157,96	163,51	166,69	174,63
	57,15	151,61	157,16	161,93	165,89	173,04
	63,50	150,02	155,58	160,34	164,31	171,45
	71,44	147,64	153,19	157,96	161,93	168,28
	76,20	146,05	151,61	155,58	159,54	165,89
	82,55	142,88	148,43	152,40	155,58	161,93
5 H 90	57,15	160,34	167,48	172,24	176,21	184,15
	63,50	159,54	165,89	171,45	175,42	183,36
	71,44	157,96	164,31	169,07	173,04	180,18
	76,20	156,37	162,72	167,48	170,66	178,59
	82,55	153,99	159,54	164,31	167,48	174,63
	88,90	150,81	155,58	160,34	163,51	171,45
5 1/2 H 90	57,15	170,66	177,01	182,56	187,33	195,26
	63,50	169,86	176,21	181,77	185,74	194,47
	71,44	168,28	174,63	180,18	184,15	192,09
	76,20	166,69	173,04	178,59	182,56	190,50
	82,55	165,10	170,66	177,01	180,18	188,12
	88,90	161,93	168,28	173,04	176,21	184,15
6 5/8 H 90	63,50	192,09	199,23	205,58	210,34	219,87
	71,44	190,50	198,44	204,79	208,76	218,28
	76,20	189,71	197,64	203,20	207,96	217,49
	82,55	188,91	196,06	201,61	206,38	215,11
	88,90	186,53	193,68	199,23	203,99	212,73

Table C.12 (continued)

Dimensions in millimetres

1	2	3	4	5	6	7
Connection label ^a	Inside diameter ^b	Outside diameter at bending-strength ratio ^c				
		1,90	2,25	2,50	2,75	3,20
7 H 90	63,50	203,20	211,93	219,08	223,84	234,95
	71,44	201,61	211,14	217,49	223,04	233,36
	76,20	200,82	210,34	216,69	222,25	232,57
	82,55	200,03	208,76	215,11	220,66	230,98
	88,90	198,44	207,17	213,52	219,87	228,60
7 5/8 H 90	71,44	232,57	242,89	250,03	257,18	268,29
	76,20	231,78	242,09	250,03	256,38	268,29
	82,55	230,98	241,30	249,24	255,59	266,70
	88,90	230,19	240,51	247,65	254,00	265,91
	95,25	229,39	238,92	246,06	252,41	264,32
8 5/8 H 90	76,20	261,94	273,84	281,78	289,72	302,42
	82,55	261,14	273,05	280,99	288,93	301,63
	88,90	260,35	272,26	280,99	288,13	300,83
	95,25	259,56	271,46	279,40	287,34	300,04
2 3/8 PAC	31,75	71,04	73,42	75,41	76,99	80,17
	38,10	68,66	70,64	72,63	73,82	76,99
	44,45	64,29	65,88	67,47	68,26	70,64
2 7/8 PAC	31,75	77,39	80,17	82,15	84,14	87,31
	38,10	75,41	77,79	79,77	81,76	84,93
	44,45	72,23	74,22	76,20	77,39	80,17
3 1/2 PAC	38,10	93,66	97,23	100,01	102,39	106,76
	44,45	92,08	95,65	98,03	100,41	104,38
	50,80	89,30	92,47	94,85	96,84	100,41
2 3/8 OH	31,75	85,33	88,50	90,88	92,87	96,84
	38,10	84,14	86,92	89,30	91,28	94,85
	44,45	81,76	84,14	86,52	88,11	91,28
2 7/8 OH	38,10	98,03	101,60	104,78	106,76	111,13
	44,45	96,44	100,01	102,79	105,17	109,14
	50,80	94,06	97,63	100,01	102,00	105,97
3 1/2 OH	38,10	124,22	129,38	132,95	136,13	141,68
	44,45	123,83	128,59	131,76	134,94	140,49
	50,80	122,63	127,40	130,57	133,75	138,91
4 OH	50,80	146,45	152,40	156,77	160,34	167,08
	57,15	145,65	151,61	155,58	159,15	165,89
	63,50	144,07	150,02	153,99	157,56	163,91
4 1/2 OH	82,55	150,81	156,37	160,34	163,91	170,26
	88,90	147,64	152,40	156,37	159,54	165,50
	95,25	143,27	147,64	150,81	153,59	159,15

^a Labels are for information and assistance in ordering.

^b Minor differences between measured inside diameters and inside diameters in the tables are of little significance; therefore, use the inside diameter from the table that is closest to the measured inside diameter.

^c The effect of stress-relief features is disregarded in calculating bending-strength ratios.

Table C.13 — Drill-collar elevator groove and slip recess

Dimensions in millimetres

1	2	3	4	5	6	7
Drill-collar OD range	Elevator-groove depth l_e^a	Radius at top of elevator groove r_{EG}	Length elevator groove L_{eg} $+25$ 0	Slip-groove depth l_s^a	Radius at top of slip groove r_{SG}	Length of slip groove L_{sg} $+50$ 0
101,60 to 117,48	5,56	3,18	406,40	4,76	25,40	457,20
120,65 to 142,88	6,35	3,18	406,40	4,76	25,40	457,20
146,05 to 168,28	7,94	3,18	406,40	6,35	25,40	457,20
171,45 to 219,08	9,52	4,76	406,40	6,35	25,40	457,20
222,25 and larger	11,11	6,35	406,40	6,35	25,40	457,20
NOTE See Figure 16.						
^a l_e and l_s dimensions are from the nominal OD of a new drill collar.						

Table C.14 — Float-valve recess in bit subs

Dimensions in millimetres

1	2	3	4	5	6
Diameter of valve assembly ^a	Length of valve assembly	Label ^b rotary-shouldered connection	Length of float recess L_R $\pm 1,6$	Length of baffle-plate recess L_{br}	Diameter of float recess D_{FR} $+0,4$ 0
42,07	149,22	2 3/8 REG	231,78	76,20	42,86
42,07	149,22	NC23	231,78	76,20	42,86
48,42	158,75	2 7/8 REG	254,00	76,20	49,21
48,42	158,75	NC26	241,30	76,20	49,21
61,12	165,10	3 1/2 REG	266,70	76,20	61,91
61,12	165,10	NC31	260,35	76,20	61,91
71,44	254,00	3 1/2 FH	355,60	76,20	72,23
79,38	254,00	NC38	361,95	76,20	80,17
88,11	211,14	4 1/2 REG	325,44	76,20	88,90
88,11	211,14	NC44	331,79	76,20	88,90
92,87	304,80	NC46	425,45	76,20	93,66
98,42	247,65	5 1/2 REG	374,65	76,20	99,22
98,42	247,65	NC50	368,30	76,20	99,22
121,44	298,45	6 5/8 REG	431,80	76,20	122,24
121,44	298,45	5 1/2 IF	431,80	76,20	122,24
121,44	298,45	7 5/8 REG	438,15	76,20	122,24
121,44	298,45	5 1/2 FH	431,80	76,20	122,24
121,44	298,45	8 5/8 REG	441,33	76,20	122,24
121,44	298,45	NC61	444,50	76,20	122,24
144,46	371,48	8 5/8 REG	514,35	76,20	145,26
144,46	371,48	6 5/8 IF	504,82	76,20	145,26
NOTE See Figure 17.					
^a The ID of the drill collar or sub and the ID of the bit pin shall be small enough to hold the valve.					
^b Labels are for information and assistance in ordering.					

Table C.15 — Used bit-box and bit-bevel diameters

Dimensions in millimetres

1	2	3	4	5
Connection label ^a	Bit-sub diameter		Bit diameter	
	minimum	maximum ^b	minimum	maximum ^b
1 REG	36,88	37,69	37,69	38,51
1 1/2 REG	48,67	49,48	49,48	50,27
2 3/8 REG	76,99	77,80	77,77	78,59
2 7/8 REG	91,28	92,08	92,08	84,93
3 1/2 REG	103,98	104,78	104,78	105,57
4 1/2 REG	134,94	135,73	135,73	136,52
5 1/2 REG	164,70	165,50	165,50	180,18
6 5/8 REG	186,53	187,32	187,32	188,12
7 5/8 REG	214,71	215,50	215,50	216,30
8 5/8 REG	242,09	242,89	242,89	243,68

^a Labels are for information and assistance in ordering.

^b The maximum bevel diameters apply only to connections that have been re-faced in the field. They are not for use on newly manufactured products.

Table C.16 — API work-string tubing EUE-connection criteria

Dimensions in millimetres

Label ^a	Length L_C	Coupling perfect thread length	Maximum power tight make-up	Minimum power tight make-up	Minimum coupling length
1,050	7,62	26,04	46,36	59,06	82,55
1,315	8,89	29,21	49,53	62,23	89,90
1,660	12,07	32,39	52,71	65,40	95,25
1,900	13,67	33,99	54,30	67,00	98,42
2 3/8	23,83	46,05	68,28	80,98	123,82
2 7/8	28,58	50,80	73,02	85,72	133,35
3 1/2	34,93	57,15	79,38	92,08	146,05
4	38,10	60,33	82,55	95,25	152,40
4 1/2	41,28	63,50	85,72	98,42	158,75

^a Labels are for information and assistance in ordering.

Table C.17 — Tool-joint mass per metre for various OD/ID combinations

Dimensions in kilograms per metre unless otherwise specified

OD mm	Tool-joint mass per metre at ID in millimetres																										
	3,5	3,8	4,1	4,4	4,8	5,1	5,4	5,7	5,5	6,2	6,4	6,5	6,7	6,8	7,0	7,1	7,3	7,6	8,3	8,7	8,8	8,9	9,2	9,5	10,2	12,1	12,7
7,3	25	24	22	—	—	—	—	—	—	—	—	—	—	—	—	—	—	—	—	—	—	—	—	—	—	—	—
7,9	31	30	28	27	25	23	21	19	—	—	—	—	—	—	—	—	—	—	—	—	—	—	—	—	—	—	—
8,6	38	36	35	33	31	29	27	25	—	—	—	—	—	—	—	—	—	—	—	—	—	—	—	—	—	—	—
8,3	34	33	31	30	28	26	24	22	23	—	—	—	—	—	—	—	—	—	—	—	—	—	—	—	—	—	—
9,5	48	47	45	44	42	40	38	36	37	32	31	30	28	27	26	24	23	20	14	9	—	—	—	—	—	—	—
9,8	—	—	—	47	46	44	42	40	41	36	35	34	32	31	30	28	27	24	18	13	—	—	—	—	—	—	—
10,2	—	—	—	51	50	48	46	43	45	40	39	37	36	35	34	32	31	28	22	17	—	—	—	—	—	—	—
10,5	—	—	—	—	—	52	50	47	49	44	43	42	40	39	38	36	35	32	26	21	—	—	—	—	—	—	—
10,8	—	—	—	—	—	56	54	52	53	48	47	46	44	43	42	40	39	36	30	25	—	—	—	—	—	—	—
11,1	—	—	—	—	—	60	58	56	58	52	51	50	49	47	46	45	43	40	34	29	—	—	—	—	—	—	—
11,4	—	—	—	—	—	65	63	60	62	57	56	54	53	52	50	49	48	45	38	34	—	—	—	—	—	—	—
11,7	—	—	—	—	—	69	67	65	67	61	60	59	58	56	55	54	52	49	43	38	—	—	—	—	—	—	—
12,1	—	—	—	—	—	74	72	70	71	66	65	64	62	61	60	58	57	54	48	43	42	—	—	—	—	—	—
12,4	—	—	—	—	—	79	76	74	76	71	70	68	67	66	64	63	62	59	52	47	47	—	—	—	—	—	—
12,7	—	—	—	—	—	83	81	79	81	76	74	73	72	71	69	68	66	64	57	52	52	—	—	—	—	—	—
13,0	—	—	—	—	—	—	—	—	86	81	80	78	77	76	74	73	72	69	62	57	57	—	—	—	—	—	—
13,3	—	—	—	—	—	—	—	—	91	86	85	83	82	81	79	78	77	74	68	63	62	—	—	—	—	—	—
13,7	—	—	—	—	—	—	—	—	96	91	90	89	87	86	85	83	82	79	73	68	67	—	—	—	—	—	—
14,0	—	—	—	—	—	—	—	—	—	97	95	94	93	91	90	89	87	84	78	73	72	—	—	—	—	—	—
14,3	—	—	—	—	—	—	—	—	—	102	101	100	98	97	96	94	93	90	84	79	78	—	—	—	—	—	—
14,6	—	—	—	—	—	—	—	—	—	108	107	105	104	103	101	100	99	96	89	84	83	79	—	—	—	—	—
14,9	—	—	—	—	—	—	—	—	—	114	112	111	110	108	107	106	104	101	95	90	88	85	—	—	—	—	—
15,2	—	—	—	—	—	—	—	—	—	119	118	117	116	114	113	112	110	107	101	96	95	94	91	—	—	—	—
15,6	—	—	—	—	—	—	—	—	—	125	124	123	122	120	119	118	116	113	107	102	101	100	97	93	—	—	—
15,9	—	—	—	—	—	—	—	—	—	132	130	129	128	126	125	124	122	119	113	108	107	107	103	99	—	—	—

Table C.17 (continued)

Dimensions in kilograms per metre unless otherwise specified

OD mm	Tool-joint mass per metre at ID in millimetres																										
	3,5	3,8	4,1	4,4	4,8	5,1	5,4	5,7	5,5	6,2	6,4	6,5	6,7	6,8	7,0	7,1	7,3	7,6	8,3	8,7	8,8	8,9	9,2	9,5	10,2	12,1	12,7
16,2	—	—	—	—	—	—	—	—	—	138	137	135	134	133	131	130	129	126	119	115	114	113	109	106	—	—	—
16,5	—	—	—	—	—	—	—	—	—	144	143	142	140	139	138	136	135	132	126	121	120	119	116	112	—	—	—
16,8	—	—	—	—	—	—	—	—	—	151	150	148	147	146	144	143	142	139	132	127	127	126	122	118	—	—	—
17,1	—	—	—	—	—	—	—	—	—	157	156	155	154	152	151	150	148	145	139	134	133	132	129	125	—	—	—
17,5	—	—	—	—	—	—	—	—	—	164	163	162	160	159	158	156	155	152	146	141	140	139	136	132	—	—	—
17,8	—	—	—	—	—	—	—	—	—	171	170	169	167	166	165	163	162	159	153	148	147	146	142	139	—	—	—
18,1	—	—	—	—	—	—	—	—	—	178	177	176	174	173	172	170	169	166	160	155	154	153	149	146	—	—	—
18,4	—	—	—	—	—	—	—	—	—	185	184	183	181	180	179	177	176	173	167	162	161	160	157	153	—	—	—
18,7	—	—	—	—	—	—	—	—	—	192	191	190	189	187	186	185	183	180	174	169	168	167	164	160	—	—	—
19,1	—	—	—	—	—	—	—	—	—	200	199	197	196	195	193	192	191	188	182	177	176	175	171	168	160	134	—
19,4	—	—	—	—	—	—	—	—	—	207	206	205	204	202	201	200	198	195	189	184	183	182	179	175	167	141	—
19,7	—	—	—	—	—	—	—	—	—	215	214	213	211	210	209	207	206	203	197	192	191	190	186	183	175	149	—
20,0	—	—	—	—	—	—	—	—	—	223	222	220	219	218	216	215	214	211	204	199	199	198	194	191	183	157	—
20,3	—	—	—	—	—	—	—	—	—	—	—	—	—	—	—	—	—	—	—	—	—	206	202	198	191	165	155
20,6	—	—	—	—	—	—	—	—	—	—	—	—	—	—	—	—	—	—	—	—	—	—	—	206	199	173	163
21,0	—	—	—	—	—	—	—	—	—	—	—	—	—	—	—	—	—	—	—	—	—	—	—	215	207	181	171
21,3	—	—	—	—	—	—	—	—	—	—	—	—	—	—	—	—	—	—	—	—	—	—	—	—	215	189	179
21,6	—	—	—	—	—	—	—	—	—	—	—	—	—	—	—	—	—	—	—	—	—	—	—	—	223	197	188

Table C.18 — Drill-collar mass per metre for various OD/ID combinations

Dimensions in kilograms per metre unless otherwise specified

OD mm	Drill-collar mass per metre at ID in millimetres												
	2,5	3,2	3,8	4,4	5,1	5,7	6,4	7,1	7,6	8,3	8,9	9,5	10,2
7,3	29	27	24	—	—	—	—	—	—	—	—	—	—
7,6	32	30	27	—	—	—	—	—	—	—	—	—	—
7,9	35	33	30	—	—	—	—	—	—	—	—	—	—
8,3	38	36	33	—	—	—	—	—	—	—	—	—	—
9,5	52	50	47	—	—	—	—	—	—	—	—	—	—
8,9	45	42	40	—	—	—	—	—	—	—	—	—	—
9,2	48	46	43	—	—	—	—	—	—	—	—	—	—
9,5	52	50	47	—	—	—	—	—	—	—	—	—	—
9,8	56	53	51	—	—	—	—	—	—	—	—	—	—
10,2	60	57	55	51	48	43	—	—	—	—	—	—	—
10,5	64	61	59	55	52	47	—	—	—	—	—	—	—
10,8	68	66	63	60	56	52	—	—	—	—	—	—	—
11,1	72	70	67	64	60	56	—	—	—	—	—	—	—
11,4	76	74	72	68	65	60	—	—	—	—	—	—	—
11,7	—	—	76	73	69	65	—	—	—	—	—	—	—
12,1	—	—	81	77	74	70	65	—	—	—	—	—	—
12,4	—	—	85	82	79	74	70	—	—	—	—	—	—
12,7	—	—	90	87	83	79	74	—	—	—	—	—	—
13,0	—	—	95	92	88	84	80	—	—	—	—	—	—
13,3	—	—	101	97	94	89	85	—	—	—	—	—	—
13,7	—	—	106	103	99	95	90	—	—	—	—	—	—
14,0	—	—	111	108	104	100	95	89	—	—	—	—	—
14,3	—	—	117	114	110	106	101	94	—	—	—	—	—
14,6	—	—	122	119	115	111	107	100	96	89	—	—	—
14,9	—	—	128	125	121	117	112	106	101	95	—	—	—
15,2	—	—	134	131	127	123	118	112	107	101	—	—	—
15,6	—	—	140	137	133	129	124	118	113	107	—	—	—
15,9	—	—	146	143	139	135	130	124	119	113	107	—	—
16,2	—	—	153	149	146	141	137	130	126	119	113	—	—
16,5	—	—	159	156	152	148	143	136	132	126	119	—	—
16,8	—	—	165	162	158	154	150	143	139	132	126	—	—
17,1	—	—	172	169	165	161	156	150	145	139	132	—	—
17,5	—	—	179	176	172	168	163	156	152	146	139	—	—
17,8	—	—	186	182	179	175	170	163	159	153	146	139	131
18,1	—	—	193	190	186	182	177	170	166	160	153	146	138
18,4	—	—	200	197	193	189	184	177	173	167	160	153	145
18,7	—	—	207	204	200	196	191	185	180	174	167	160	153
19,1	—	—	215	211	208	203	199	192	188	182	175	168	160
19,4	—	—	222	219	215	211	206	200	195	189	182	175	167
19,7	—	—	230	226	223	218	214	207	203	197	190	183	175

Table C.18 (continued)

Dimensions in kilograms per metre unless otherwise specified

OD mm	Drill-collar mass per metre at ID in millimetres												
	2,5	3,2	3,8	4,4	5,1	5,7	6,4	7,1	7,6	8,3	8,9	9,5	10,2
20,0	—	—	237	234	230	226	222	215	211	204	198	191	183
20,3	—	—	245	242	238	234	229	223	218	212	206	198	191
20,6	—	—	253	250	246	242	237	231	227	220	214	206	199
21,0	—	—	261	258	255	250	246	239	235	228	222	215	207
21,3	—	—	270	266	263	259	254	247	243	237	230	223	215
21,6	—	—	278	275	271	267	262	256	251	245	238	231	223
22,9	—	—	313	310	306	302	297	290	286	280	273	266	258
23,5	—	—	331	328	324	320	315	308	304	298	291	284	276
24,1	—	—	350	346	343	338	334	327	323	317	310	303	295
24,8	—	—	369	365	362	358	353	346	342	336	329	322	314
25,4	—	—	388	385	381	377	372	366	362	355	349	341	334
26,7	—	—	429	426	422	418	413	407	402	396	389	382	374
27,9	—	—	472	469	465	461	456	449	445	439	432	425	417
29,2	—	—	516	513	510	505	501	494	490	483	477	470	462
30,5	—	—	563	560	556	552	547	541	536	530	523	516	509

Annex D (informative)

USC units

Table D.1 — Longitudinal magnetizing force for inside-diameter inspections

1	2	3	4	5
Label ^a	Outside diameter in	Ampere turns		Minimum gauss in air at centre of coil
		8 in ID coil	10 in ID coil	
2 3/8	2 3/8	6 400	7 400	270
2 7/8	2 7/8	6 700	7 800	285
3 1/2	3 1/2	7 200	8 300	305
4	4	7 600	8 700	320
4 1/2	4 1/2	7 900	9 100	335
5	5	8 200	9 600	350
5 1/2	5 1/2	8 600	10 000	365
6 5/8	6 5/8	N/A	10 900	400

^a Labels are for information and assistance in ordering.

Table D.2 — Current requirements of internal conductor magnetization

1	2	3	4
Number of pulses	Power supply type		Capacitor discharge units ^a Amps per lb/ft
	Battery Amps per in	3-phase rectified AC Amps per in	
One	300	300	240
Two	N/A	N/A	180
Three	N/A	N/A	145

^a To determine the amperage required, multiply the value in column 4 by the linear mass, expressed in pounds per foot, of the pipe.

**Table D.3 — Compensated thread lengths and contact-point size
for lead measurements parallel to taper cone**

Threads per inch	Pitch	Taper in/in	Contact-point size for lead gauge ± 0.002 in	Thread length (parallel to thread axis) ^a in	Compensated length (parallel to taper cone) ^a in
5	0.200	1/6	0.115	1	1.003 47
5	0.200	1/4	0.115	1	1.007 78
4	0.250	1/8	0.144	1	1.001 95
4	0.250	1/6	0.144	1	1.003 47
4	0.250	1/4	0.144	1	1.007 78
3.5	0.285 71	1/6	0.202	2	2.006 93
3.5	0.285 71	1/4	0.202	2	2.015 56
3	0.333 3	5/48	0.236	1	1.001 36

^a Thread length is parallel to thread length. Compensated thread length is for measurements parallel to the taper cone.

Table D.4 — Dimensional values for classification of drill-pipe tubes

1	2	3	4	5	6	7	8	9	10	11	12
Label 1 ^a	Label 2 ^a	Weight code ^b	OD in	Nominal linear mass lb/ft	Nominal wall in	Wall at percent remaining in		OD at percent increase in		OD at percent reduction in	
						80 %	70 %	4 %	3 %	3 %	4 %
2 3/8	4.85	1	2.375	4.85	0.190	0.152	0.133	2.470	2.446	2.304	2.280
2 3/8	6.65	2	2.375	6.65	0.280	0.224	0.196	2.470	2.446	2.304	2.280
2 7/8	6.85	1	2.875	6.85	0.217	0.174	0.152	2.990	2.961	2.789	2.760
2 7/8	10.40	2	2.875	10.40	0.362	0.290	0.253	2.990	2.961	2.789	2.760
3 1/2	9.50	1	3.500	9.50	0.254	0.203	0.178	3.640	3.605	3.395	3.360
3 1/2	13.30	2	3.500	13.30	0.368	0.294	0.258	3.640	3.605	3.395	3.360
3 1/2	15.50	3	3.500	15.50	0.449	0.359	0.314	3.640	3.605	3.395	3.360
4	11.85	1	4.000	11.85	0.262	0.210	0.183	4.160	4.120	3.880	3.840
4	14.00	2	4.000	14.00	0.330	0.264	0.231	4.160	4.120	3.880	3.840
4	15.70	3	4.000	15.70	0.380	0.304	0.266	4.160	4.120	3.880	3.840
4 1/2	13.75	1	4.500	13.75	0.271	0.217	0.190	4.680	4.635	4.365	4.320
4 1/2	16.60	2	4.500	16.60	0.337	0.270	0.236	4.680	4.635	4.365	4.320
4 1/2	20.00	3	4.500	20.00	0.430	0.344	0.301	4.680	4.635	4.365	4.320
4 1/2	22.82	4	4.500	22.82	0.500	0.400	0.350	4.680	4.635	4.365	4.320
4 1/2	24.66	5	4.500	24.66	0.550	0.440	0.385	4.680	4.635	4.365	4.320
4 1/2	25.50	6	4.500	25.50	0.575	0.460	0.402	4.680	4.635	4.365	4.320
5	16.25	1	5.000	16.25	0.296	0.237	0.207	5.200	5.150	4.850	4.800
5	19.50	2	5.000	19.50	0.362	0.290	0.253	5.200	5.150	4.850	4.800
5	25.60	3	5.000	25.60	0.500	0.400	0.350	5.200	5.150	4.850	4.800
5 1/2	19.20	1	5.500	19.20	0.304	0.243	0.213	5.720	5.665	5.335	5.280
5 1/2	21.90	2	5.500	21.90	0.361	0.289	0.253	5.720	5.665	5.335	5.280
5 1/2	24.70	3	5.500	24.70	0.415	0.332	0.290	5.720	5.665	5.335	5.280
6 5/8	25.20	2	6.625	25.20	0.330	0.264	0.231	6.890	6.824	6.426	6.360
6 5/8	27.70	3	6.625	27.70	0.362	0.290	0.253	6.890	6.824	6.426	6.360

^a Labels are for information and assistance in ordering.

^b Weight code 2 designates standard mass for this pipe size.

Table D.5 — Dimensional values for classification of work-string tubing

1	2	3	4	5	6	7	8	9	10	11	12	13	14
Label 1 ^a	Label 2 ^a	OD in	Nominal linear mass lb/ft	Nominal wall in	Wall at percent remaining in			Maximum OD at percent increase in			Maximum OD at percent decrease in		
					87.5 %	80 %	70 %	4 %	3 %	2 %	2 %	3 %	4 %
1.050	1.20	1.050	1.20	0.113	0.099	0.090	0.079	1.092	1.082	1071	1.029	1.018	1.008
1.050	1.50	1.050	1.50	0.154	0.135	0.123	0.108	1.092	1.082	1071	1.029	1.018	1.008
1.315	1.80	1.315	1.80	0.133	0.116	0.106	0.093	1.368	1.354	1.341	1.289	1.276	1.262
1.315	2.25	1.315	2.25	0.179	0.157	0.143	0.125	1.368	1.354	1.341	1.289	1.276	1.262
1.660	2.40	1.660	2.40	0.140	0.122	0.112	0.098	1.726	1.710	1.693	1.627	1.610	1.594
1.660	3.02	1.660	3.02	0.191	0.167	0.153	0.134	1.726	1.710	1.693	1.627	1.610	1.594
1.660	3.24	1.660	3.24	0.198	0.173	0.158	0.139	1.726	1.710	1.693	1.627	1.610	1.594
1.900	2.90	1.900	2.90	0.145	0.127	0.116	0.102	1.976	1.957	1.938	1.862	1.843	1.824
1.900	3.64	1.900	3.64	0.200	0.175	0.160	0.140	1.976	1.957	1.938	1.862	1.843	1.824
1.900	4.19	1.900	4.19	0.219	0.192	0.175	0.153	1.976	1.957	1.938	1.862	1.843	1.824
2.063	3.25	2.063	3.25	0.156	0.136	0.125	0.109	2.146	2.125	2.104	2.022	2.001	1.980
2.063	4.50	2.063	4.50	0.225	0.197	0.180	0.157 5	2.146	2.125	2.104	2.022	2.001	1.980
2 3/8	4.70	2 3/8	4.70	0.190	0.166	0.152	0.133	2.470	2.446	2.422	2.328	2.304	2.280
2 3/8	5.30	2 3/8	5.30	0.218	0.191	0.174	0.153	2.470	2.446	2.422	2.328	2.304	2.280
2 3/8	5.95	2 3/8	5.95	0.254	0.222	0.203	0.178	2.470	2.446	2.422	2.328	2.304	2.280
2 3/8	7.70	2 3/8	7.70	0.336	0.294	0.269	0.236	2.470	2.446	2.422	2.328	2.304	2.280
2 7/8	6.50	2 7/8	6.50	0.217	0.190	0.174	0.152	2.990	2.961	2.933	2.818	2.789	2.760
2 7/8	7.90	2 7/8	7.90	0.276	0.242	0.221	0.193	2.990	2.961	2.933	2.818	2.789	2.760
2 7/8	8.70	2 7/8	8.70	0.308	0.270	0.246	0.216	2.990	2.961	2.933	2.818	2.789	2.760
2 7/8	9.50	2 7/8	9.50	0.340	0.296	0.272	0.238	2.990	2.961	2.933	2.818	2.789	2.760
2 7/8	10.70	2 7/8	10.70	0.392	0.343	0.314	0.274	2.990	2.961	2.933	2.818	2.789	2.760
2 7/8	11.00	2 7/8	11.00	0.405	0.354	0.324	0.284	2.990	2.961	2.933	2.818	2.789	2.760
3 1/2	9.30	3 1/2	9.30	0.254	0.222	0.203	0.178	3.640	3.605	3.570	3.430	3.395	3.360
3 1/2	12.80	3 1/2	12.80	0.368	0.322	0.294	0.258	3.640	3.605	3.570	3.430	3.395	3.360
3 1/2	12.95	3 1/2	12.95	0.375	0.328	0.300	0.262	3.640	3.605	3.570	3.430	3.395	3.360
3 1/2	15.80	3 1/2	15.80	0.476	0.416	0.381	0.333	3.640	3.605	3.570	3.430	3.395	3.360
3 1/2	16.70	3 1/2	16.70	0.510	0.446	0.408	0.357	3.640	3.605	3.570	3.430	3.395	3.360
4 1/2	15.50	4 1/2	15.50	0.337	0.295	0.267	0.236	4.680	4.635	4.590	4.410	4.365	4.320
4 1/2	19.20	4 1/2	19.20	0.430	0.376	0.344	0.301	4.680	4.635	4.590	4.410	4.365	4.320

^a Labels are for information and assistance in ordering.

Table D.6 — Used tool-joint criteria

1	2	3	4	5	6	7	8	9	10	11	12
Pipe data					Premium class			Class 2			
Label 1 ^a	Label 2 ^a	New pipe OD	Nominal linear mass	Pipe grade	Tool-joint connection label ^a	Minimum OD tool joint	Maximum ID tool joint	Minimum box shoulder width eccentric wear	Minimum OD tool joint	Maximum ID tool joint	Minimum box shoulder width eccentric wear
		in	lb/ft			D_{tj} in	d_{tj} in	S_w in	D_{tj} in	d_{tj} in	S_w in
2 3/8	4.85	2 3/8	4.85	E75	NC26	3 1/8	1 31/32	3/64	3 3/32	2 1/16	1/32
					WO	3 1/16	2 1/8	1/16	3 1/32	2 5/32	3/64
					2 3/8 OHLW	3	2 3/32	1/16	2 31/32	2 5/32	3/64
					2 3/8 SL-H90	2 31/32	2 3/16	1/16	2 15/16	2 7/32	3/64
2 3/8	6.65	2 3/8	6.65	E75	2 3/8 PAC	2 25/32	1 3/8	9/64	2 23/32	1 19/32	7/64
					NC26	3 3/16	2 3/32	5/64	3 5/32	2 5/32	1/16
					2 3/8 SL-H90	3 1/32	2 3/32	3/32	2 31/32	2 5/32	1/16
					2 3/8 OHSW	3 1/16	2 1/16	3/32	3 1/32	2 1/8	5/64
				X95	NC26	3 1/4	2	7/64	3 7/32	2 3/32	3/32
				G105	NC26	3 9/32	1 15/16	1/8	3 1/4	2 1/32	7/64
2 7/8	6.85	2 7/8	6.85	E75	NC31	3 11/16	2 17/32	5/64	3 21/32	2 11/16	1/16
					2 7/8 WO	3 5/8	2 19/32	5/64	3 19/32	2 21/32	1/16
					2 7/8 OHLW	3 1/2	2 7/16	7/64	3 7/16	2 1/2	5/64
					2 7/8 SL-H90	3 1/2	2 19/32	3/32	3 7/16	2 5/8	1/16
2 7/8	10.40	2 7/8	10.40	E75	NC31	3 13/16	2 1/2	9/64	3 3/4	2 19/32	7/64
					2 7/8 XH	3 23/32	2 13/32	9/64	3 21/32	2 1/2	7/64
					NC26	3 3/8	1 23/32	11/64	3 11/32	1 27/32	5/32
					2 7/8 OHSW	3 19/32	2 9/32	5/32	3 9/16	2 3/8	7/64
					2 7/8 SL H90	3 19/32	2 15/32	9/64	3 17/32	2 17/32	7/64
					2 7/8 PAC	3 1/8	1 7/32	15/64	3 1/8	1 13/32	15/64
				X95	NC31	3 29/32	2 5/16	3/16	3 27/32	2 7/16	5/32
					2 7/8 SL-H90	3 11/16	2 5/16	3/16	3 5/8	2 13/32	5/32
				G105	NC31	3 15/16	2 1/4	13/64	3 7/8	2 3/8	11/64
				S135	NC31	4 1/16	2 1/32	17/64	4	2 13/16	15/64
3 1/2	9.50	3 1/2	9.50	E75	NC38	4 13/32	3 3/16	1/8	4 11/32	2 1/4	3/32
					3 1/2 OHLW	4 9/32	3 3/32	1/8	4 1/4	3 5/32	7/64
					3 1/2 SL-H90	4 3/16	3 5/32	7/64	4 5/32	3 3/16	3/32

Table D.6 (continued)

1	2	3	4	5	6	7	8	9	10	11	12
Pipe data					Premium class			Class 2			
Label 1 ^a	Label 2 ^a	New pipe OD	Nominal linear mass	Pipe grade	Tool-joint connection label ^a	Minimum OD tool joint	Maximum ID tool joint	Minimum box shoulder width eccentric wear	Minimum OD tool joint	Maximum ID tool joint	Minimum box shoulder width eccentric wear
		in	lb/ft			D_{tj} in	d_{tj} in	S_w in	D_{tj} in	d_{tj} in	S_w in
3 1/2	13.30	3 1/2	13.3	E75	NC38	4 1/2	3 1/16	11/64	4 7/16	3 1/8	9/64
					NC31	4	2 1/8	15/64	3 15/16	2 9/32	13/64
					3 1/2 OHSW	4 13/32	2 15/16	3/16	4 11/32	3 1/16	5/32
					3 1/2 H90	4 17/32	3 5/16	1/8	4 1/2	3 3/8	7/64
				X95	NC38	4 19/32	2 7/8	7/32	4 17/32	3	3/16
					3 1/2 SL-H90	4 3/8	2 7/8	13/64	4 5/16	2 31/32	11/64
					3 1/2 H90	4 5/8	3 5/32	11/64	4 9/16	3 1/4	9/64
				G105	NC38	4 21/32	2 25/32	1/4	4 19/32	2 7/8	7/32
				S135	NC40	5	2 29/32	9/32	4 29/32	3 1/16	15/64
NC38	4 13/16	2 17/32	21/64		4 23/32	2 29/32	9/32				
3 1/2	15.50	3 1/2	15.5	E75	NC38	4 17/32	2 31/32	3/16	4 15/32	3 3/32	5/32
				X95	NC38	4 21/32	2 25/32	1/4	4 19/32	2 29/32	7/32
				G105	NC38	4 23/32	2 21/32	9/32	4 5/8	2 13/16	15/64
				S135	NC38	4 29/32	2 11/32	9/32	4 25/32	2 19/32	3/16
				G105	NC40	4 15/16	3 1/16	1/4	4 27/32	3 3/16	13/64
				S135	NC40	5 3/32	2 13/16	21/64	4 31/32	2 31/32	17/64
4	11.85	4	11.85	E75	NC46	5 7/32	4 1/32	7/64	5 5/32	4 3/32	5/64
					4 WO	5 7/32	4 1/32	7/64	5 5/32	4 3/32	5/64
4	11.85	4	11.85	E75	4 OHLW	5	3 25/32	9/64	4 15/16	3 27/32	7/64
					4 H90	4 7/8	3 23/32	7/64	4 27/32	3 25/32	3/32
4	14.00	4	14	E75	NC40	4 13/16	3 1/4	3/16	4 3/4	3 11/32	5/32
					NC46	5 9/32	3 15/16	9/64	5 7/32	4 1/32	7/64
					4 SH	4 7/16	2 19/32	15/64	4 3/8	2 23/32	13/64
					4 OHSW	5 1/16	3 11/16	11/64	5	3 25/32	9/64
					4 H90	4 15/16	3 21/32	9/64	4 7/8	3 23/32	7/64
				X95	NC40	4 15/16	3 1/16	1/4	4 27/32	3 3/16	13/64
					NC46	5 3/8	3 13/16	3/16	5 5/16	3 15/16	5/32
					4 H90	5 1/32	3 1/2	3/16	4 31/32	3 19/32	5/32
				G105	NC40	5	2 15/16	9/32	4 29/32	3 3/32	15/64
					NC46	5 7/16	3 3/4	7/32	5 11/32	3 27/32	11/64
					4 H90	5 3/32	3 7/16	7/32	5 1/32	3 15/32	3/16
				S135	NC46	5 9/16	3 1/2	9/32	5 1/2	3 21/32	1/4

Table D.6 (continued)

1	2	3	4	5	6	7	8	9	10	11	12				
Pipe data					Premium class			Class 2							
Label 1 ^a	Label 2 ^a	New pipe OD	Nominal linear mass	Pipe grade	Tool-joint connection label ^a	Minimum OD tool joint	Maximum ID tool joint	Minimum box shoulder width eccentric wear	Minimum OD tool joint	Maximum ID tool joint	Minimum box shoulder width eccentric wear				
		in	lb/ft			D_{tj} in	d_{tj} in	S_w in	D_{tj} in	d_{tj} in	S_w in				
4	15.70	4	15.7	E75	NC40	4 7/8	3 1/8	7/32	4 25/32	3 9/32	11/64				
					NC46	5 5/16	3 29/32	5/32	5 1/4	3 31/32	1/8				
					4 H90	4 31/32	3 19/32	5/32	4 29/32	3 21/32	1/8				
				X95	NC40	5	2 31/32	9/32	4 29/32	3 3/32	15/64				
					NC46	5 7/16	3 3/4	7/32	5 11/32	3 27/32	11/64				
					4 H90	5 3/32	3 7/16	7/32	5 1/32	3 17/32	3/16				
				G105	NC46	5 15/32	3 21/32	15/64	5 13/32	3 25/32	13/64				
					4 H90	5 5/32	3 11/32	1/4	5 1/16	3 15/32	13/64				
				S135	NC46	5 21/32	3 13/32	21/64	5 17/32	3 9/16	17/64				
4 1/2	16.60	4 1/2	16.60	E75	4 1/2 FH	5 3/8	3 5/8	13/64	5 9/32	3 23/32	5/32				
					NC46	5 13/32	3 25/32	13/64	5 11/32	3 7/8	11/64				
					4 1/2 OHSW	5 7/16	3 15/16	13/64	5 3/8	4 1/32	11/64				
					NC50	5 23/32	4 5/16	5/32	5 11/16	4 13/32	9/64				
				X95	4 1/2 H-90	5 11/32	3 29/32	3/16	5 9/32	4	5/32				
					4 1/2 FH	5 1/2	3 13/32	17/64	5 13/32	3 9/16	7/32				
					NC46	5 17/32	3 19/32	17/64	5 7/16	3 23/32	7/32				
					NC50	5 27/32	4 5/32	7/32	5 25/32	4 1/4	3/16				
				G105	4 1/2 H-90	5 15/32	3 3/4	1/4	5 3/8	3 27/32	13/64				
					4 1/2 FH	5 9/16	3 21/32	19/64	5 15/32	3 25/32	1/4				
					NC46	5 19/32	3 1/2	19/64	5 1/2	3 5/8	1/4				
					NC50	5 29/32	4 1/16	1/4	5 13/16	4 3/16	13/64				
				S135	4 1/2 H-90	5 1/2	3 21/32	17/64	5 7/16	3 25/32	15/64				
					NC46	5 25/32	3 5/32	25/64	5 21/32	3 3/8	21/64				
				4 1/2	20.00	4 1/2	20.00	E75	NC46	5 15/32	3 1/2	1/4	5 3/8	3 5/8	13/64
									NC46	5 1/2	3 5/8	1/4	5 13/32	3 3/4	13/64
									NC50	5 13/16	4 3/16	13/64	5 3/4	4 5/16	3/16
								X95	4 1/2 H-90	5 13/32	3 25/32	7/32	5 11/32	3 7/8	3/16
4 1/2 FH	5 5/8	3 7/32	21/64						5 17/32	3 3/8	9/32				
NC46	5 21/32	3 13/32	21/64						5 9/16	3 9/16	9/32				
NC50	5 15/16	4	17/64						5 7/8	4 1/8	15/64				
4 1/2	20.00	4 1/2	20	X95	4 1/2 H-90	5 9/16	3 9/16	19/64	5 15/32	3 23/32	1/4				
				G105	NC46	5 23/32	3 1/4	23/64	5 5/8	3 15/32	5/16				
					NC50	6 1/32	3 29/32	5/16	5 29/32	4 1/32	1/4				
				S135	NC50	6 7/32	3 19/32	13/32	6 3/32	3 25/32	11/32				

Table D.6 (continued)

1	2	3	4	5	6	7	8	9	10	11	12
Pipe data					Premium class			Class 2			
Label 1 ^a	Label 2 ^a	New pipe OD	Nominal linear mass	Pipe grade	Tool-joint connection label ^a	Minimum OD tool joint	Maximum ID tool joint	Minimum box shoulder width eccentric wear	Minimum OD tool joint	Maximum ID tool joint	Minimum box shoulder width eccentric wear
		in	lb/ft			D_{tj} in	d_{tj} in	S_w in	D_{tj} in	d_{tj} in	S_w in
5	19.50	5	19.5	E75	NC50	5 7/8	4 3/32	15/64	5 13/16	4 7/32	13/64
				X95	NC50	6 1/32	3 7/8	5/16	5 15/16	4	17/64
					5 H-90	5 27/32	3 27/32	19/64	5 3/4	3 21/32	1/4
				G105	NC50	6 3/32	3 25/32	11/32	6	3 15/16	19/64
					5 H-90	5 29/32	3 3/4	21/64	5 13/16	3 7/8	9/32
				S135	NC50	6 5/16	3 3/32	29/64	6 3/16	3 5/8	25/64
5 1/2 FH	6 3/4	4 1/4	3/8		6 5/8	4 3/32	5/16				
5	25.60	5	25.6	E75	NC50	6 1/32	3 29/32	5/16	5 15/16	4 1/32	17/64
					5 1/2 FH	6 1/2	4 5/8	1/4	6 3/32	4 3/4	13/64
				X95	NC50	6 7/32	3 9/16	13/32	6 3/32	3 25/32	11/32
					5 1/2 FH	6 21/32	4 3/8	21/64	6 9/16	4 17/32	9/32
				G105	NC50	6 9/32	3 7/16	7/16	6 5/32	3 21/32	3/8
					5 1/2 FH	6 23/32	4 9/32	23/64	6 5/8	4 7/16	5/16
S135	5 1/2 FH	6 15/16	3 29/32	15/32	6 13/16	4 1/8	13/32				
5 1/2	21.90	5 1/2	21.90	E75	5 1/2 FH	6 15/32	4 5/8	15/64	6 3/32	4 3/4	13/64
				X95	5 1/2 FH	6 5/8	4 11/32	5/16	6 17/32	4 17/32	17/64
					5 1/2 H-90	6 3/16	3 15/16	21/64	6 3/32	4 5/32	9/32
				G105	5 1/2 FH	6 23/32	4 9/32	23/64	6 19/32	4 7/16	19/64
S135	5 1/2 FH	6 15/16	3 15/16	15/32	6 13/16	4 5/32	13/32				
5 1/2	24.70	5 1/2	24.70	E75	5 1/2 FH	6 9/16	4 17/32	9/32	6 15/32	4 11/16	15/64
				X95	5 1/2 FH	6 23/32	4 9/32	23/64	6 19/32	4 7/16	19/64
				G105	5 1/2 FH	6 25/32	4 5/32	25/64	6 11/16	4 11/32	11/32
				S135	5 1/2 FH	7 1/32	3 23/32	33/64	6 7/8	4	7/16
6 5/8	25.20	6 5/8	25.20	E75	6 5/8 FH	7 7/16	5 15/32	1/4	7 3/8	5 9/16	7/32
				X95	6 5/8 FH	7 5/8	5 3/16	11/32	7 1/2	5 3/8	9/32
				G105	6 5/8 FH	7 11/16	5 3/32	5/8	7 19/32	5 9/32	21/64
				S135	6 5/8 FH	7 29/32	4 11/16	31/64	7 25/32	4 15/16	27/64
6 5/8	27.70	6 5/8	27.70	E75	6 5/8 FH	7 1/2	5 3/8	9/32	7 13/32	5 1/2	15/64
				X95	6 5/8 FH	7 11/16	5 3/32	3/8	7 9/16	5 9/32	5/16
				G105	6 5/8 FH	7 3/4	4 15/16	13/32	7 21/32	5 1/8	23/64
				S135	6 5/8 FH	8	4 17/32	17/32	7 27/32	4 25/32	29/64

^a Labels are for information and assistance in ordering.

Table D.7 — Tool-joint-connection dimensional requirements

Dimensions in inches

1	2	3	4	5	6	7	8
Label ^a rotary-shouldered connection	Counterbore diameter Q_c max.	Counter-bore length L_{qc} min.	Length pin L_{PC} min.	Length pin L_{PC} max.	Length pin base L_{pb} max.	Length box threads L_{BT} min.	Box depth L_{BC} min.
NC23	2 11/16	9/16	2 7/8	3 1/16	9/16	3 1/16	3 9/16
NC26	3	9/16	2 7/8	3 1/16	9/16	3 1/16	3 9/16
NC31	3 33/64	9/16	3 3/8	3 9/16	9/16	3 9/16	4 1/16
NC35	3 7/8	9/16	3 5/8	3 3/16	9/16	3 13/16	4 5/16
NC38	4 9/64	9/16	3 7/8	4 1/16	9/16	4 1/16	4 9/16
NC40	4 13/32	9/16	4 3/8	4 9/16	9/16	4 9/16	5 1/16
NC44	4 3/4	9/16	4 3/8	4 9/16	9/16	4 9/16	5 1/16
NC46	4 31/32	9/16	4 3/8	4 9/16	9/16	4 9/16	5 1/16
NC50	5 3/8	9/16	4 3/8	4 9/16	9/16	4 9/16	5 1/16
NC56	6	9/16	4 7/8	5 1/16	9/16	5 1/16	5 9/16
NC61	6 9/16	9/16	5 3/8	5 9/16	9/16	5 9/16	6 1/16
NC70	7 7/16	9/16	5 7/8	6 1/16	9/16	6 1/16	6 9/16
NC77	8 1/8	9/16	6 3/8	6 9/16	9/16	6 9/16	7 1/16
2 3/8 SH	2 9/16	9/16	2 3/4	2 15/16	9/16	3 1/16	3 9/16
2 7/8 SH	3	9/16	2 7/8	3 1/16	9/16	3 1/16	3 9/16
3 1/2 SH	3 33/64	9/16	3 3/8	3 9/16	9/16	3 9/16	4 1/16
4 SH	3 15/16	9/16	3 3/8	3 9/16	9/16	3 9/16	4 9/16
4 1/2 SH	4 9/64	9/16	3 7/8	4 1/16	9/16	4 9/16	5
2 3/8 PAC	2 15/32	5/16	2 1/4	2 7/16	5/16	2 7/16	2 15/16
2 7/8 PAC	2 41/64	5/16	2 1/4	2 7/16	5/16	2 7/16	2 15/16
2 3/8 SLH-90	2 53/64	9/16	2 3/4	2 7/8	1/4	2 15/16	3 7/16
2 7/8 SLH-90	3 19/64	9/16	2 7/8	3	1/4	3 1/16	3 9/16
2 3/8 OH	2 55/64	9/16	2 1/4	2 7/16	5/16	2 7/16	2 15/16
2 7/8 OH	3 17/64	9/16	2 3/4	2 15/16	5/16	2 15/16	3 5/16
2 7/8 XH	3 27/64	9/16	3 7/8	4 1/16	9/16	4 1/16	4 9/16
3 1/2 XH	3 15/16	9/16	3 3/8	3 9/16	9/16	3 9/16	4 1/16
4 1/2 FH	4 15/16	9/16	3 7/8	4 1/16	9/16	4 1/16	5 9/16
5 1/2 FH	5 31/32	9/16	4 7/8	5 1/16	9/16	5 1/16	5 9/16
6 5/8 FH	6 29/32	9/16	4 7/8	5 1/16	9/16	5 1/16	5 9/16
2 3/8 IF	3	9/16	2 7/8	3 1/16	9/16	3 1/16	3 9/16
2 7/8 IF	3 33/64	9/16	3 3/8	3 9/16	9/16	3 9/16	4 1/16
3 1/2 IF	4 9/64	9/16	3 7/8	4 1/16	9/16	4 1/16	4 9/16
5 1/2 IF	6 33/64	9/16	4 7/8	5 1/16	9/16	5 1/16	5 9/16
6 5/8 IF	7 37/64	9/16	4 7/8	5 1/16	9/16	5 1/16	5 9/16
3 1/2 H-90	4 1/4	9/16	3 7/8	4 1/16	7/16	4 1/16	4 9/16
4 H-90	4 5/8	9/16	4 1/8	4 5/16	7/16	4 5/16	4 13/16
4 1/2 H-90	4 61/64	9/16	4 3/8	4 9/16	7/16	4 9/16	5 1/16
5 H-90	5 15/64	9/16	4 5/8	4 13/16	7/16	4 13/16	5 5/16
5 1/2 H-90	5 1/2	9/16	4 5/8	4 13/16	7/16	4 13/16	5 5/16
6 5/8 H-90	6 1/8	9/16	4 7/8	5 1/16	7/16	5 1/16	5 9/16

NOTE See Figures 9 and 10.

^a Labels are for information and assistance in ordering.

Table D.8 — Used tool-joint bevel diameters ^a

Dimensions in inches

1	2	3	4	5	6
Label ^b rotary-shouldered connection	Label ^b interchangeable rotary-shouldered connections		Used tool-joint OD range ^c	Bevel diameter D_F minimum ^c	Bevel diameter D_F maximum ^d
NC26	2 3/8 IF	2 7/8 SH	3 17/64 to 3 3/8	3 1/4	3 13/32
NC31	2 7/8 IF	3 1/2 SH	3 61/64 to 4 3/8	3 15/16	4 3/32
NC38	3 1/2 IF	—	4 39/64 to 5	4 9/16	4 23/32
NC40	4 FH	—	5 1/64 to 5 1/2	5	5 5/32
NC46	4 IF	4 1/2 XH	5 23/32 to 6 1/4	5 45/64	5 55/64
NC50	4 1/2 IF	5 XH	6 1/16 to 6 5/8	6 3/64	6 13/64
NC56	—	—	6 47/64 to 7	6 23/32	6 7/8
3 1/2 FH	—	—	4 31/64 to 4 5/8	4 15/32	4 5/8
4 FH	—	—	5 1/64 to 5 1/2	5	5 5/32
4 1/2 FH	—	—	5 23/32 to 6 1/4	5 45/64	5 55/64
5 1/2 FH	—	—	6 23/32 to 7 1/4	6 45/64	6 55/64
5 1/2 FH	—	—	7 3/32 to 7 1/2	7 5/64	7 15/64
6 5/8 FH	—	—	7 45/64 to 8 1/2	7 11/16	7 27/32
4 H-90	—	—	5 17/64 to 5 1/2	5 1/4	5 13/32
4 1/2 H-90	—	—	5 23/32 to 6	5 45/64	5 55/64
2 7/8 SH	NC26	2 3/8 IF	3 17/64 to 3 3/8	3 1/4	3 13/32
3 1/2 SH	NC31	2 7/8 IF	3 61/64 to 4 3/8	3 15/16	4 3/32
4 SH	—	—	4 25/64 to 4 5/8	4 21/64	4 31/64
3 1/2 XH	—	—	4 17/32 to 4 3/4	4 33/64	4 43/64
4 1/2 XH	NC46	4 IF	5 23/32 to 6 1/4	5 45/64	5 55/64
5 XH	NC50	4 1/2 IF	6 1/16 to 6 5/8	6 3/64	6 13/64

NOTE See Figures 2 and 10.

^a Tool-joint bevel diameters apply to drill-pipe tool joints, lower kelly connections, kelly-saver subs, HWDP and all connections that make up to these connections.

^b Labels are for information and assistance in ordering.

^c When the OD becomes smaller than the minimum bevel diameter shown, a reduced bevel of 1/32 in × 45° shall be ground or machined onto the full circumference of the sealing face of the pin or box. The reduced bevel shall not be cause for rejection.

^d The maximum bevel diameter is for connections that have been re-faced with portable refacing equipment at the rig or warehouse. It is not for connections re-machined in a machine shop.

Table D.9 — Drill-collar connection dimensions (without stress-relief features)

Dimensions in inches

1	2	3	4	5	6	7	8
Label ^a rotary-shouldered connection	Counter-bore diameter Q_c or D_{LTorq} maximum	Counter-bore length L_{qc} minimum	Length pin L_{PC} minimum	Length pin L_{PC} maximum	Length pin base L_{pb} maximum	Length box threads L_{BT} minimum	Box depth L_{BC} minimum
NC23	2 11/16	9/16	2 7/8	3 1/16	9/16	3 1/16	3 9/16
NC26	3	9/16	2 7/8	3 1/16	9/16	3 1/16	3 9/16
NC31	3 33/64	9/16	3 3/8	3 9/16	9/16	3 9/16	4 1/16
NC35	3 7/8	9/16	3 5/8	3 13/16	9/16	3 13/16	4 5/16
NC38	4 9/64	9/16	3 7/8	4 1/16	9/16	4 1/16	4 9/16
NC40	4 13/32	9/16	4 3/8	4 9/16	9/16	4 9/16	5 1/16
NC44	4 3/4	9/16	4 3/8	4 9/16	9/16	4 9/16	5 1/16
NC46	4 31/32	9/16	4 3/8	4 9/16	9/16	4 9/16	5 1/16
NC50	5 3/8	9/16	4 3/8	4 9/16	9/16	4 9/16	5 1/16
NC56	6	9/16	4 7/8	5 1/16	9/16	5 1/16	5 9/16
NC61	6 9/16	9/16	5 3/8	5 9/16	9/16	5 9/16	6 1/16
NC70	7 7/16	9/16	5 7/8	6 1/16	9/16	6 1/16	6 9/16
NC77	8 1/8	9/16	6 3/8	6 9/16	9/16	6 9/16	7 1/16
2 3/8 REG	2 3/4	9/16	2 7/8	3 1/16	9/16	3 1/16	3 9/16
2 7/8 REG	3 1/8	9/16	3 3/8	3 9/16	9/16	3 9/16	4 1/16
3 1/2 REG	3 5/8	9/16	3 5/8	3 13/16	9/16	3 13/16	4 5/16
4 1/2 REG	4 3/4	9/16	4 1/8	4 5/16	9/16	4 5/16	4 13/16
5 1/2 REG	5 41/64	9/16	4 5/8	4 13/16	9/16	4 13/16	5 5/16
6 5/8 REG	6 1/8	9/16	4 7/8	5 1/16	9/16	5 1/16	5 9/16
7 5/8 REG FF	7 5/32	9/16	5 1/8	5 5/16	9/16	5 5/16	5 13/16
7 5/8 REG LT	7 13/16	5/16	5 1/8	5 5/16	9/16	5 5/16	5 13/16
8 5/8 REG FF	8 7/64	9/16	5 1/4	5 7/16	9/16	5 7/16	5 15/16
8 5/8 REG LT	9 1/16	5/16	5 1/4	5 7/16	9/16	5 7/16	5 15/16
2 3/8 SH	2 9/16	9/16	2 7/8	3 1/16	9/16	3 1/16	3 9/16
2 7/8 SH	3	9/16	2 7/8	3 1/16	9/16	3 1/16	3 9/16
3 1/2 SH	3 33/64	9/16	3 3/8	3 9/16	9/16	3 9/16	4 1/16
4 SH	3 15/16	9/16	3 3/8	3 9/16	9/16	3 9/16	4 9/16
4 1/2 SH	4 9/64	9/16	3 7/8	4 1/16	9/16	4 1/16	4 9/16
2 3/8 PAC	2 15/32	5/16	2 1/4	2 7/16	5/16	2 7/16	2 15/16
2 7/8 PAC	2 41/64	5/16	2 1/4	2 7/16	5/16	2 7/16	2 15/16
3 1/2 PAC	3 11/64	5/16	3 1/8	3 5/16	5/16	3 5/16	3 13/16
2 3/8 SLH-90	2 53/64	9/16	2 3/4	2 7/8	1/4	2 15/16	3 7/16
2 7/8 SLH-90	3 19/64	9/16	2 7/8	3	1/4	3 1/16	3 9/16
2 3/8 OH	2 7/8	9/16	2 1/4	2 7/16	5/16	2 7/16	2 15/16
2 7/8 OH	3 1/4	9/16	2 3/4	2 15/16	5/16	2 15/16	3 5/16
2 7/8 XH	3 27/64	9/16	3 7/8	4 1/16	9/16	4 1/16	4 9/16
3 1/2 XH	3 15/16	9/16	3 3/8	3 9/16	9/16	3 9/16	4 1/16
3 1/2 FH	4 7/64	9/16	3 5/8	3 13/16	9/16	3 13/16	4 5/16

Table D.9 (continued)

Dimensions in inches

1	2	3	4	5	6	7	8
Label ^a rotary-shouldered connection	Counter-bore diameter Q_c or D_{LTorq} maximum	Counter-bore length L_{qc} minimum	Length pin L_{PC} minimum	Length pin L_{PC} maximum	Length pin base L_{pb} maximum	Length box threads L_{BT} minimum	Box depth L_{BC} minimum
4 FH	4 13/32	9/16	4 3/8	4 9/16	9/16	4 9/16	5 1/16
4 1/2 FH	4 15/16	9/16	3 7/8	4 1/16	9/16	4 1/16	5 9/16
5 1/2 FH	5 31/64	9/16	4 7/8	5 1/16	9/16	5 1/16	5 9/16
6 5/8 FH	6 29/32	9/16	4 7/8	5 1/16	9/16	5 1/16	5 9/16
2 3/8 IF	3	9/16	2 7/8	3 1/16	9/16	3 1/16	3 9/16
2 7/8 IF	3 33/64	9/16	3 3/8	3 9/16	9/16	3 9/16	4 1/16
3 1/2 IF	4 9/64	9/16	3 7/8	4 1/16	9/16	4 1/16	4 9/16
5 1/2 IF	6 33/64	9/16	4 7/8	5 1/16	9/16	5 1/16	5 9/16
6 5/8 IF	7 37/64	9/16	4 7/8	5 1/16	9/16	5 1/16	5 9/16
3 1/2 H-90	4 1/4	9/16	3 7/8	4 1/16	7/16	4 1/16	4 9/16
4 H-90	4 5/8	9/16	4 1/8	4 5/16	7/16	4 5/16	4 13/16
4 1/2 H-90	4 61/64	9/16	4 3/8	4 9/16	7/16	4 9/16	5 1/16
5 H-90	5 15/64	9/16	4 5/8	4 13/16	7/16	4 13/16	5 5/16
5 1/2 H-90	5 1/2	9/16	4 5/8	4 13/16	7/16	4 13/16	5 5/16
6 5/8 H-90	6 1/8	9/16	4 7/8	5 1/16	7/16	5 1/16	5 9/16
7 H-90 FF	6 5/8	9/16	5 3/8	5 9/16	7/16	5 9/16	6 1/16
7 H-90 LT	7 3/16	11/32	5 3/8	5 9/16	7/16	5 9/16	6 1/16
7 5/8 H-90 FF	7 33/64	9/16	6	6 3/16	7/16	6 3/16	6 11/16
7 5/8 H-90 LT	8 1/16	11/32	6	6 3/16	7/16	6 3/16	6 11/16
8 5/8 H-90 FF	8 25/64	9/16	6 1/2	6 11/16	7/16	6 11/16	4 3/16
8 5/8 H-90 LT	9 7/16	11/32	6 1/2	6 11/16	7/16	6 11/16	4 3/16
NOTE See Figures 9, 10 and 11.							
^a Labels are for information and assistance in ordering.							

Table D.10 — Dimensional limits on used bottom-hole-assembly connections with stress-relief features^a

Dimensions in inches

1	2	5	3	4	6	7	8	9	10
Label ^b rotary-shouldered connection	Counter-bore diameter Q_C or D_{LTorq} maximum	Counter-bore length L_{qc} minimum	Length pin L_{PC} minimum	Length pin L_{PC} maximum	Pin relief groove dia. D_{RG} minimum	Pin relief groove dia. D_{RG} maximum	Box boreback cylinder dia. D_{cb} minimum	Box boreback cylinder dia. D_{cb} maximum	Box boreback thread vanish point L_X ref.
NC35	3 7/8	3 5/8	3 13/16	9/16	3.2	3.231	3 15/64	3 1/4	3 1/4
NC38	4 9/64	3 7/8	4 1/16	9/16	3.477	3.508	3 15/32	3 31/64	3 1/2
NC40	4 13/32	4 3/8	4 9/16	9/16	3.741	3.772	3 21/32	3 43/64	4
NC44	4 3/4	4 3/8	4 9/16	9/16	4.086	4.117	4	4 1/64	4
NC46	4 31/32	4 3/8	4 9/16	9/16	4.295	4.326	4 13/64	4 7/32	4
NC50	5 3/8	4 3/8	4 9/16	9/16	4.711	4.742	4 5/8	4 41/64	4
NC56	6	4 7/8	5 1/16	9/16	5.246	5.277	4 51/64	4 13/16	4 1/2
NC61	6 9/16	5 3/8	5 9/16	9/16	5.808	5.839	5 15/64	5 1/4	5
NC70	7 7/16	4 7/8	6 1/16	9/16	6.683	6.714	5 63/64	6	5 1/2
NC77	8 1/8	6 3/8	6 9/16	9/16	7.371	7.402	6 35/64	6 9/16	6
4 1/2 REG	4 3/4	4 1/8	4 5/16	9/16	3.982	4.013	3 23/32	3 47/64	3 3/4
5 1/2 REG	5 41/64	4 5/8	4 13/16	9/16	4.838	4.869	4 1/2	4 33/64	4 1/4
6 5/8 REG	6 1/8	4 7/8	5 1/16	9/16	5.386	5.417	5 9/32	5 19/64	4 1/2
7 5/8 REG FF	7 5/32	5 1/8	5 5/16	9/16	6.318	6.349	5 55/64	5 23/32	4 3/4
7 5/8 REG LT	7 13/16	5 1/8	5 5/16	5/16	6.318	6.349	5 55/64	5 23/32	4 1/2
8 5/8 REG FF	8 7/64	5 1/4	5 7/16	9/16	7.27	7.301	6 25/32	6 51/64	4 7/8
8 5/8 REG LT	9 1/16	5 1/4	5 7/16	5/16	7.27	7.301	6 25/32	6 51/64	4 7/8
4 1/2 SH	4 9/64	3 7/8	4 1/16	9/16	3.477	3.508	3 15/32	3 31/64	3 1/2
3 1/2 FH	4 7/64	3 5/8	3 13/16	9/16	3 25/64	3 27/64	3 7/32	3 15/64	3 1/4
4 FH	4 13/32	4 3/8	4 9/16	9/16	3.741	3.772	3 21/32	3 43/64	4
4 1/2 FH	4 15/16	3 7/8	4 1/16	9/16	4.149	4.18	3 61/64	3 31/32	3 1/2
5 1/2 FH	5 31/64	4 7/8	5 1/16	9/16	5 7/32	5 1/4	5 7/64	5 1/8	4 1/2
6 5/8 FH	6 29/32	4 7/8	5 1/16	9/16	6 9/64	6 11/64	6 3/64	6 1/16	4 1/2
3 1/2 IF	4 9/64	3 7/8	4 1/16	9/16	3.477	3.508	3 15/32	3 31/64	3 1/2
5 1/2 IF	6 31/32	4 7/8	5 1/16	9/16	5 55/64	5 57/64	5 11/16	5 45/64	4 1/2
6 5/8 IF	7 37/64	4 7/8	5 1/16	9/16	6 59/64	6 61/64	6 3/4	6 49/64	4 1/2
3 1/2 H-90	4 1/4	3 7/8	4 1/16	9/16	3 5/8	3 21/32	3 9/16	3 37/64	3 1/2
4 H-90	4 5/8	4 1/8	4 5/16	9/16	4	4 1/32	3 7/8	3 57/64	3 3/4
4 1/2 H-90	4 61/64	4 3/8	4 9/16	9/16	4 21/64	4 23/64	4 3/16	4 13/64	4
5 H-90	5 15/64	4 5/8	4 13/16	9/16	4 19/32	4 5/8	4 13/32	4 27/64	4 1/4
5 1/2 H-90	5 1/2	4 5/8	4 13/16	9/16	4 7/8	4 29/32	4 11/64	4 3/16	4 1/4
6 5/8 H-90	6 1/8	4 7/8	5 1/16	9/16	5 1/2	5 17/32	5 17/64	4 1/4	4 1/2
7 H-90 FF	6 5/8	5 3/8	5 9/16	9/16	6	6 1/32	5 17/64	4 1/4	5
7 H-90 LT	7 3/16	5 3/8	5 9/16	11/32	6	6 1/32	5 17/64	4 1/4	5
7 5/8 H-90 FF	7 33/64	6	6 3/16	9/16	6 7/8	6 29/32	6	6 1/64	5 5/8
7 5/8 H-90 LT	8 1/16	6	6 3/16	11/32	6 7/8	6 29/32	6	6 1/64	5 5/8
8 5/8 H-90 FF	8 25/64	6 1/2	6 11/16	9/16	7 3/4	7 25/32	6 3/4	6 49/64	6 1/8

NOTE See Figures 9, 11, 12 and 13.

^a Bottom-hole-assembly connections include all connections between, but not including, the bit and the drill pipe.^b Labels are for information and assistance in ordering.

Table D.11 — Used drill-collar bevel diameters

Dimensions in inches

1	2	3	4	5	6
Label ^a rotary-shouldered connection	Label ^a interchangeable rotary-shouldered connections		Drill-collar outside-diameter range ^b	Bevel diameter D_F minimum	Bevel diameter D_F maximum ^c
NC23	—	—	3 1/8 to 3 1/4	2 63/64	3 9/64
NC26	3 3/8 IF	2 7/8 SH	3 3/8 to 3 39/64	3 1/4	3 13/32
			3 5/8 to 3 55/64	3 7/16	3 19/32
			3 7/8 to 4	3 5/8	3 25/32
NC31	2 7/8 IF	—	4 1/8 to 4 23/64	3 15/16	4 3/32
			4 3/8 to 4 5/8	4 1/8	4 9/32
NC35	—	—	4 3/4 to 4 63/64	4 1/2	4 21/32
NC38	3 1/2 IF	4 1/2 SH	4 3/4 to 4 63/64	4 9/16	4 23/32
			5 to 5 15/64	4 3/4	4 29/32
			5 1/4 to 5 31/64	4 15/16	4 3/32
NC40	4 FH	—	5 1/4 to 5 31/64	5	5 5/32
			5 1/2 to 5 47/64	5 3/16	5 11/32
			5 3/4 to 5 63/64	5 3/8	5 17/32
NC44	—	—	5 3/4 to 5 63/64	5 31/64	5 41/64
			6 to 6 15/64	5 43/64	5 53/64
			6 1/4 to 6 31/64	5 55/64	6 1/64
NC46	4 IF	4 1/2 XH	6 to 6 15/64	5 45/64	5 55/64
			6 1/4 to 6 23/64	5 57/64	6 3/64
			6 1/2 to 6 47/64	6 5/64	6 15/64
			6 3/4 to 6 63/64	6 17/64	6 27/64
NC50	4 1/2 IF	5 XH	6 1/8 to 6 23/64	6 3/64	6 13/64
			6 3/8 to 6 39/64	6 3/32	6 1/4
			6 5/8 to 6 55/64	6 9/32	6 7/16
			6 7/8 to 7 7/64	6 15/32	6 5/8
			7 1/8 to 7 23/64	6 21/32	6 13/16
NC56	—	—	7 1/2 to 7 47/64	7 3/32	7 1/4
			7 3/4 to 7 63/64	7 9/32	7 7/16
			8 to 8 15/64	7 15/32	7 5/8
NC61	—	—	8 1/4 to 8 31/64	7 51/64	7 61/64
			8 1/2 to 8 47/64	7 63/64	8 9/64
			8 3/4 to 8 63/64	8 11/64	8 21/64
			9 to 9 15/64	8 23/64	8 33/64
NC70	—	—	9 1/2 to 9 47/64	8 61/64	9 7/64
			9 3/4 to 9 63/64	9 9/64	9 9/32
			10 to 10 15/64	9 21/64	9 31/64
NC77	—	—	11 to 11 15/64	10 1/4	10 13/32
2 3/8 REG	—	—	3 1/4 to 3 23/64	3	3 5/32
			3 3/8 to 3 1/2	3 3/16	3 11/32
2 7/8 REG	—	—	3 7/8 to 4	3 9/16	3 23/32

Table D.11 (continued)

Dimensions in inches

1	2	3	4	5	6
Label ^a rotary-shouldered connection	Label ^a interchangeable rotary-shouldered connections		Drill-collar outside-diameter range ^b	Bevel diameter D_F minimum	Bevel diameter D_F maximum ^c
3 1/2 REG	—	—	4 1/4 to 4 31/32	4 1/16	4 7/32
			4 1/2 to 4 5/8	4 1/4	4 23/32
4 1/2 REG	—	—	5 5/8 to 5 47/64	5 9/32	5 7/16
			5 3/4 to 5 63/64	5 15/32	5 5/8
			6 to 6 1/8	5 21/32	5 13/16
5 1/2 REG	—	—	6 5/8 to 6 47/64	6 17/64	6 27/64
			6 3/4 to 6 63/64	6 29/64	6 39/64
			7 to 7 15/64	6 41/64	6 51/64
			7 1/4 to 7 31/32	6 53/64	6 63/64
6 5/8 REG	—	—	7 1/2 to 7 47/64	7 1/8	7 9/32
			7 3/4 to 7 63/64	7 5/16	7 15/32
			8 to 8 15/64	7 1/2	7 5/8
			8 1/4 to 8 3/8	7 11/16	7 27/32
7 5/8 REG FF	—	—	8 5/8 to 8 55/64	8 15/64	8 25/64
			8 7/8 to 9 7/64	8 27/64	8 37/64
			9 1/8 to 9 23/64	8 39/64	8 49/64
			9 3/8 to 9 39/64	8 51/64	8 61/64
7 5/8 REG LT	—	—	9 5/8 to 10	9 15/64	9 25/64
8 5/8 REG FF	—	—	9 5/8 to 9 47/64	9 1/8	9 9/32
			9 3/4 to 9 63/64	9 5/16	9 15/32
			10 to 10 15/64	9 1/2	9 21/32
			10 1/4 to 10 31/64	9 11/16	9 27/32
			10 1/2 to 10 39/64	9 7/8	10 1/32
8 5/8 REG LT	—	—	10 5/8 to 11 1/8	10 31/64	10 41/64
3 1/2 FH	—	—	4 7/8 to 5 7/64	4 21/32	4 13/16
			5 1/8 to 5 23/64	4 27/32	5
4 1/2 FH	—	—	5 3/4 to 5 63/64	5 33/64	5 43/64
			6 to 6 15/64	5 45/64	5 55/64
			6 1/4 to 6 31/64	5 57/64	6 3/64
5 1/2 FH	—	—	6 7/8 to 6 63/64	6 33/64	6 43/64
			7 to 7 15/64	6 45/64	6 55/64
			7 1/4 to 7 31/64	6 57/64	7 3/64
			7 1/2 to 7 47/64	7 5/64	7 15/64
			7 3/4 to 7 63/64	7 17/64	7 27/64
8 to 8 15/64	7 29/64	7 39/64			

Table D.11 (continued)

Dimensions in inches

1	2	3	4	5	6
Label ^a rotary-shouldered connection	Label ^a interchangeable rotary-shouldered connections		Drill-collar outside-diameter range ^b	Bevel diameter D_F minimum	Bevel diameter D_F maximum ^c
6 5/8 FH	—	—	8 to 8 15/64	7 11/16	7 27/32
			8 1/4 to 8 31/64	7 7/8	8 1/32
			8 1/2 to 8 47/64	8 1/16	8 7/32
			8 3/4 to 8 63/64	8 1/4	8 13/32
			9 to 9 15/64	8 7/16	8 19/32
			9 1/4 to 9 1/2	8 5/8	8 25/32
2 3/8 SL H-90	—	—	3 1/4 to 3 3/8	3 7/64	3 17/64
2 7/8 SL H-90	—	—	4 1/8 to 4 15/64	3 55/64	4 1/64
			4 1/4 to 4 5/16	4 7/64	4 17/64
3 1/2 SL H-90	—	—	4 7/8 to 4 63/64	4 39/64	4 49/64
			5 to 5 1/8	4 55/64	5 1/64
3 1/2 H-90	—	—	5 to 5 15/64	4 51/64	4 61/64
			5 1/4 to 5 1/2	4 63/64	5 9/64
4 H-90	—	—	6 to 6 7/64	5 31/64	5 41/64
			6 1/8 to 6 1/4	5 47/64	5 57/64
4 1/2 H-90	—	—	6 to 6 15/64	5 47/64	5 57/64
			6 1/4 to 6 39/64	5 63/64	6 9/64
			6 5/8 to 6 3/4	6 15/64	6 25/64
5 H-90	—	—	6 1/2 to 6 47/64	6 7/64	6 17/64
			6 3/4 to 7	6 23/64	6 33/64
5 1/2 H-90	—	—	6 3/4 to 6 57/64	6 23/64	6 33/64
			6 7/8 to 7 1/2	6 39/64	6 49/64
6 5/8 H-90	—	—	7 5/8 to 7 47/64	7 15/64	7 25/64
			7 3/4 to 8 1/4	7 31/64	7 41/64
7 H-90	—	—	8 1/4 to 8 31/64	7 63/64	8 9/64
			8 1/2 to 8 5/8	8 15/64	8 25/64
7 H-90 LT	—	—	8 5/8 to 8 63/64	8 15/64	8 25/64
			9 to 9 1/8	8 39/64	8 49/64
7 5/8 H-90	—	—	9 1/2 to 9 5/8	9 15/64	9 25/64
7 5/8 H-90 LT	—	—	9 3/4 to 9 55/64	9 15/64	9 25/64
			9 7/8 to 10 1/4	9 39/64	9 49/64
8 5/8 H-90	—	—	10 1/2 to 10 5/8	9 63/64	10 9/64
8 5/8 H-90 LT	—	—	10 3/4 to 11 15/64	10 31/64	10 41/64
			11 1/4 to 11 1/2	10 47/64	10 57/64
2 3/8 PAC	—	—	2 3/4 to 2 63/64	2 11/16	2 27/32
			3 to 3 1/8	2 47/64	2 57/64
2 7/8 PAC	—	—	3 1/8 to 3 1/4	2 63/64	3 9/64
2 3/8 OH	—	—	3 1/16 to 3 3/16	2 63/64	3 9/64

Table D.11 (continued)

Dimensions in inches

1	2	3	4	5	6
Label ^a rotary-shouldered connection	Label ^a interchangeable rotary-shouldered connections		Drill-collar outside-diameter range ^b	Bevel diameter D_F minimum	Bevel diameter D_F maximum ^c
2 7/8 OH	—	—	3 3/4 to 3 63/64	3 19/32	3 3/4
			4 to 4 1/4	3 47/64	3 57/64
2 3/8 SH	—	—	3 1/8 to 3 3/16	2 61/64	3 7/64
3 1/2 SH	—	—	4 1/8 to 4 23/64	3 15/16	4 3/32
			4 3/8 to 4 1/2	4 1/8	4 9/32
4 SH	3 1/2 XH	—	4 3/4 to 4 63/64	4 33/64	4 43/64
			5 to 5 1/8	4 45/64	4 55/64
2 7/8 XH	3 1/2 DSL	—	4 1/8 to 4 23/64	3 53/64	3 63/64
			4 3/8 to 4 1/2	4 1/64	4 11/64
5 1/2 IF	—	—	7 1/2 to 7 39/64	7 1/8	7 9/32
			7 5/8 to 7 55/64	7 5/16	7 15/32
			7 7/8 to 8 7/64	7 1/2	7 21/32
			8 1/8 to 8 23/64	7 11/16	7 27/32
			8 3/8 to 8 9/16	7 7/8	8 1/32
			8 5/8 to 8 55/64	8 1/16	8 7/32
			8 7/8 to 9	8 1/4	8 13/32
6 5/8 IF	—	—	9 to 9 15/64	8 39/64	8 49/64
			9 1/4 to 9 31/32	8 51/64	8 61/64
			9 1/2 to 9 47/64	8 63/64	9 9/64
			9 3/4 to 9 63/64	9 11/64	9 21/64
			10 to 10 1/4	9 23/64	9 33/64

NOTE 1 See Figures 10 and 12.

NOTE 2 Drill-collar connections include all connections between, but not including, the bit, HWDP and/or the drill pipe.

^a Labels are for information and assistance in ordering.^b Maximum OD for a connection label may be too large for that connection label. The user should check the connection bending-strength ratio and the connection torsional balance before accepting that OD.^c Maximum bevel diameter is for connections that have been re-faced in the field. Bevels on newly machined connections shall be in accordance with ISO 10424-1.

Table D.12 — Bending-strength ratios for bottom-hole assemblies

Dimensions in inches

1	2	3	4	5	6	7
Connection label ^a	Inside diameter ^b	Outside diameter at bending-strength ratio ^c				
		1.90	2.25	2.50	2.75	3.20
NC23	1 1/4	2 29/32	3 1/32	3 3/32	3 3/16	3 5/16
	1 1/2	2 13/16	2 15/16	3	3 1/16	3 13/64
	1 3/4	2 11/16	2 49/64	2 53/64	2 57/64	2 63/64
NC26	1 1/2	3 5/16	3 7/16	3 17/32	3 5/8	3 49/64
	1 3/4	3 7/32	3 11/32	3 13/32	3 1/2	3 41/64
	2	3 1/16	3 5/32	3 1/4	3 5/16	3 27/64
NC31	1 1/2	4 1/32	4 3/16	4 5/16	4 13/32	4 39/64
	1 3/4	3 31/32	4 1/8	4 1/4	4 11/32	4 17/32
	2	3 29/32	4 1/16	4 5/32	4 1/4	4 27/64
NC35	1 1/2	4 1/2	4 11/16	4 13/16	4 15/16	5 5/32
	1 3/4	4 15/16	4 21/32	4 25/32	4 29/32	5 7/64
	2	4 13/32	4 19/32	4 23/32	4 27/32	5 1/32
	2 1/4	4 11/32	4 1/2	4 5/8	4 23/32	4 59/64
	2 1/2	4 3/16	4 11/32	4 15/32	4 9/16	4 47/64
NC38	1 1/2	4 7/8	5 3/32	5 7/32	5 3/8	5 19/32
	1 3/4	4 27/32	5 1/16	5 3/16	5 5/16	5 35/64
	2	4 13/16	5	5 1/8	5 9/32	5 1/2
	2 1/4	4 3/4	4 15/16	5 1/16	5 3/16	5 13/32
	2 1/2	4 21/32	4 13/16	4 15/16	5 1/16	5 17/64
NC40	2	5 5/32	5 3/8	5 17/32	5 21/32	5 29/32
	2 1/4	5 1/8	5 5/16	5 15/32	5 19/32	5 13/16
	2 1/2	5 1/32	5 7/32	5 3/8	5 1/2	5 3/4
	2 13/16	4 57/64	5 1/16	5 7/32	5 5/16	5 9/16
NC44	2	5 21/32	5 7/8	6 1/16	6 3/16	6 15/32
	2 1/4	5 5/8	5 27/32	6 1/32	6 5/32	6 7/16
	2 1/2	5 9/16	5 25/32	5 15/16	6 1/16	6 11/32
	2 13/16	5 1/2	5 21/32	5 13/16	5 15/16	6 3/16
NC46	2	5 31/32	6 3/16	6 3/8	6 17/32	6 13/16
	2 1/4	5 15/16	6 5/32	6 11/32	6 15/32	6 25/32
	2 1/2	5 7/8	6 3/32	6 9/32	6 13/32	6 23/32
	2 13/16	5 25/32	6	6 3/16	6 5/16	6 19/32
	3	5 23/32	5 29/32	6 3/32	6 7/32	6 15/32
	3 1/4	5 19/32	5 25/32	5 15/16	6 1/16	6 5/16
NC50	2 1/4	6 17/32	6 25/32	6 31/32	7 1/8	7 15/32
	2 1/2	6 15/32	6 23/32	6 15/16	7 3/32	7 13/32
	2 13/16	6 13/32	6 21/32	6 27/32	7	7 5/16
	3	6 3/8	6 19/32	6 25/32	6 15/16	7 1/4
	3 1/4	6 9/32	6 1/2	6 11/16	6 13/16	7 1/8
	3 1/2	6 5/32	6 3/8	6 17/32	6 11/16	6 15/16

Table D.12 (continued)

Dimensions in inches

1	2	3	4	5	6	7
Connection label ^a	Inside diameter ^b	Outside diameter at bending-strength ratio ^c				
		1.90	2.25	2.50	2.75	3.20
NC56	2 1/4	7 5/32	7 15/32	7 11/16	7 7/8	8 1/4
	2 1/2	7 1/8	7 7/16	7 21/32	7 27/32	8 7/32
	2 13/16	7 1/16	7 3/8	7 19/32	7 25/32	8 5/32
	3	7 1/32	7 5/16	7 9/16	7 23/32	8 3/32
	3 1/4	6 31/32	7 1/4	7 15/32	7 21/32	8
	3 1/2	6 7/8	7 5/32	7 3/8	7 17/32	7 7/8
NC61	2 1/2	7 7/8	8 7/32	8 15/32	8 11/16	9 3/32
	2 13/16	7 27/32	8 5/32	8 7/16	8 5/8	9 1/32
	3	7 13/16	8 1/8	8 13/32	8 19/32	9
	3 1/4	7 3/4	8 3/32	8 11/32	8 17/32	8 15/16
	3 1/2	7 11/16	8	8 1/4	8 15/32	8 27/32
NC70	2 1/2	9 1/32	9 7/16	9 3/4	9 31/32	10 7/16
	2 13/16	9	9 13/32	9 23/32	9 15/16	10 13/32
	3	9	9 13/32	9 11/16	9 15/16	10 3/8
	3 1/4	8 31/32	9 11/32	9 21/32	9 7/8	10 11/32
	3 1/2	8 29/32	9 5/16	9 19/32	9 27/32	10 9/32
	3 3/4	8 7/8	9 1/4	9 17/32	9 13/16	10 7/32
NC77	2 13/16	9 15/16	10 3/8	10 11/16	10 31/32	11 15/32
	3	9 29/32	10 3/8	10 11/16	10 31/32	11 7/16
	3 1/4	9 7/8	10 11/32	10 21/32	10 15/16	11 13/32
	3 1/2	9 27/32	10 5/16	10 5/8	10 7/8	11 3/8
	3 3/4	9 13/16	10 1/4	10 9/16	10 27/32	11 11/32
2 3/8 REG	1 1/4	2 27/32	2 31/32	3 1/16	3 1/8	3 9/32
	1 1/2	2 3/4	2 7/8	2 15/16	3	3 5/32
2 7/8 REG	1 1/4	3 11/32	3 15/32	3 19/32	3 11/16	3 7/8
	1 1/2	3 9/32	3 7/16	3 17/32	3 5/8	3 13/16
	1 3/4	3 3/16	3 5/16	3 7/16	3 1/2	3 11/16
3 1/2 REG	1 1/2	4	4 5/32	4 5/16	4 13/32	4 5/8
	1 3/4	3 15/16	4 3/32	4 1/4	4 11/32	4 17/32
	2	3 55/64	4	4 5/32	4 1/4	4 7/16
4 1/2 REG	2	5 15/32	5 23/32	5 29/32	6 1/32	6 5/16
	2 1/4	5 7/16	5 21/32	5 27/32	5 31/32	6 9/32
	2 1/2	5 3/8	5 19/32	5 25/32	5 29/32	6 3/16
5 1/2 REG	2 1/4	6 19/32	6 29/32	7 1/8	7 9/32	7 5/8
	2 1/2	6 9/16	6 27/32	7 1/16	7 7/32	7 9/16
	2 13/16	6 17/32	6 25/32	7	7 5/32	7 1/2
	3	6 15/32	6 23/32	6 15/16	7 3/32	7 13/32
	3 1/4	6 3/8	6 5/8	6 27/32	7	7 5/16
	3 1/2	6 1/4	6 1/2	6 11/16	6 27/32	7 3/16

Table D.12 (continued)

Dimensions in inches

1	2	3	4	5	6	7
Connection label ^a	Inside diameter ^b	Outside diameter at bending-strength ratio ^c				
		1.90	2.25	2.50	2.75	3.20
6 5/8 REG	2 1/2	7 7/16	7 3/4	7 31/32	8 5/32	8 17/32
	2 13/16	7 13/32	7 11/16	7 29/32	8 3/32	8 15/32
	3	7 3/8	7 21/32	7 7/8	8 1/16	8 13/32
	3 1/4	7 5/16	7 19/32	7 13/16	8	8 11/32
	3 1/2	7 1/4	7 1/2	7 23/32	7 15/16	8 7/32
7 5/8 REG	2 1/2	8 5/8	9	9 9/32	9 1/2	9 15/16
	2 13/16	8 19/32	8 31/32	9 7/32	9 15/32	9 7/8
	3	8 9/16	8 15/16	9 3/16	9 7/16	9 27/32
	3 1/4	8 17/32	8 7/8	9 5/32	9 13/32	9 13/16
	3 1/2	8 15/32	8 27/32	9 3/32	9 5/16	9 25/32
	3 3/4	8 13/32	8 25/32	9 1/32	9 1/4	9 21/32
8 5/8 REG	2 13/16	9 29/32	10 11/32	10 21/32	10 29/32	11 13/32
	3	9 7/8	10 5/16	10 5/8	10 7/8	11 3/8
	3 1/4	9 7/8	10 9/32	10 19/32	10 7/8	11 11/32
	3 1/2	9 27/32	10 1/4	10 9/16	10 13/16	11 5/16
	3 3/4	9 13/16	10 7/32	10 17/32	10 25/32	11 1/4
2 7/8 FH	1 1/2	4 3/16	4 3/8	4 1/2	4 5/8	4 27/32
	1 3/4	4 5/32	4 5/16	4 7/16	4 9/16	4 25/32
	2	4 1/16	4 1/4	4 3/8	4 15/32	4 11/16
3 1/2 FH	1 1/2	4 11/16	4 29/32	5 1/16	5 5/32	5 13/32
	1 3/4	4 21/32	4 27/32	5	5 1/8	5 3/8
	2	4 5/8	4 25/32	4 15/16	5 1/16	5 5/16
	2 1/4	4 17/32	4 23/32	4 7/8	4 31/32	5 3/16
	2 1/2	4 13/32	4 19/32	4 3/4	4 27/32	5 1/16
4 1/2 FH	2	5 3/4	5 31/32	6 3/16	6 5/16	6 5/8
	2 1/4	5 11/16	5 15/16	6 1/8	6 1/4	6 9/16
	2 1/2	5 21/32	5 7/8	6 1/16	6 3/16	6 15/32
	2 13/16	5 17/32	5 3/4	5 15/16	6 1/16	6 11/32
	3	5 29/64	5 21/32	5 27/32	5 31/32	6 1/4
	3 1/4	5 5/16	5 1/2	5 11/16	5 13/16	6 1/16
5 1/2 FH	2 1/4	7 1/4	7 17/32	7 3/4	7 15/16	8 9/32
	2 1/2	7 7/32	7 1/2	7 23/32	7 29/32	8 1/4
	2 13/16	7 5/32	7 7/16	7 21/32	7 27/32	8 3/16
	3	7 1/8	7 13/32	7 5/8	7 25/32	8 1/8
	3 1/4	7 1/16	7 3/8	7 9/16	7 3/4	8 1/32
	3 1/2	7	7 9/32	7 7/16	7 5/8	7 15/16
6 5/8 FH	2 1/2	8 17/32	8 7/8	9 1/8	9 11/32	9 3/4
	2 13/16	8 1/2	8 27/32	9 3/32	9 5/16	9 23/32
	3	8 15/32	8 13/16	9 1/16	9 9/32	9 11/16
	3 1/4	8 7/16	8 3/4	9 1/32	9 7/32	9 5/8
	3 1/2	8 3/8	8 23/32	8 31/32	9 5/32	9 9/16
	3 3/4	8 5/16	8 5/8	8 7/8	9 3/32	9 15/32

Table D.12 (continued)

Dimensions in inches

1	2	3	4	5	6	7
Connection label ^a	Inside diameter ^b	Outside diameter at bending-strength ratio ^c				
		1.90	2.25	2.50	2.75	3.20
3 1/2 H 90	2	5 1/32	5 7/32	5 3/8	5 1/2	5 3/4
	2 1/4	4 31/32	5 1/8	5 5/16	5 13/32	5 21/32
	2 1/2	4 7/8	5 1/32	5 3/16	5 5/16	5 17/32
4 H 90	2	5 17/32	5 3/4	5 15/16	6 1/16	6 11/32
	2 1/4	5 1/2	5 11/16	5 7/8	6	6 9/32
	2 1/2	5 7/16	5 5/8	5 13/16	5 15/16	6 3/16
	2 13/16	5 5/16	5 1/2	5 11/16	5 13/16	6 1/32
4 1/2 H 90	2	6	6 7/32	6 7/16	6 9/16	6 7/8
	2 1/4	5 31/32	6 3/16	6 3/8	6 17/32	6 13/16
	2 1/2	5 29/32	6 1/8	6 5/16	6 15/32	6 3/4
	2 13/16	5 13/16	6 1/32	6 7/32	6 3/8	6 5/8
	3	5 3/4	5 31/32	6 1/8	6 9/32	6 17/32
	3 1/4	5 5/8	5 27/32	6	6 1/8	6 3/8
5 H 90	2 1/4	6 5/16	6 19/32	6 25/32	6 15/16	7 1/4
	2 1/2	6 9/32	6 17/32	6 3/4	6 29/32	7 7/32
	2 13/16	6 7/32	6 15/32	6 21/32	6 13/16	7 3/32
	3	6 5/32	6 13/32	6 19/32	6 23/32	7 1/32
	3 1/4	6 1/16	6 9/32	6 15/32	6 19/32	6 7/8
	3 1/2	5 15/16	6 1/8	6 5/16	6 7/16	6 3/4
5 1/2 H 90	2 1/4	6 23/32	6 31/32	7 3/16	7 3/8	7 11/16
	2 1/2	6 11/16	6 15/16	7 5/32	7 5/16	7 21/32
	2 13/16	6 5/8	6 7/8	7 3/32	7 1/4	7 9/16
	3	6 9/16	6 13/16	7 1/32	7 3/16	7 1/2
	3 1/4	6 1/2	6 23/32	6 31/32	7 3/32	7 13/32
	3 1/2	6 3/8	6 5/8	6 13/16	6 15/16	7 1/4
6 5/8 H 90	2 1/2	7 9/16	7 27/32	8 3/32	8 9/32	8 21/32
	2 13/16	7 1/2	7 13/16	8 1/16	8 7/32	8 19/32
	3	7 15/32	7 25/32	8	8 3/16	8 9/16
	3 1/4	7 7/16	7 23/32	7 15/16	8 1/8	8 15/32
	3 1/2	7 11/32	7 5/8	7 27/32	8 1/32	8 3/8
7 H 90	2 1/2	8	8 11/32	8 5/8	8 13/16	9 1/4
	2 13/16	7 15/16	8 5/16	8 9/16	8 25/32	9 3/16
	3	7 29/32	8 9/32	8 17/32	8 3/4	9 5/32
	3 1/4	7 7/8	8 7/32	8 15/32	8 11/16	9 3/32
	3 1/2	7 13/16	8 5/32	8 13/32	8 21/32	9
7 5/8 H 90	2 13/16	9 5/32	9 9/16	9 27/32	10 1/8	10 9/16
	3	9 1/8	9 17/32	9 27/32	10 3/32	10 9/16
	3 1/4	9 3/32	9 1/2	9 13/16	10 1/16	10 1/2
	3 1/2	9 1/16	9 15/32	9 3/4	10	10 15/32
	3 3/4	9 1/32	9 13/32	9 11/16	9 15/16	10 13/32

Table D.12 (continued)

Dimensions in inches

1	2	3	4	5	6	7
Connection label ^a	Inside diameter ^b	Outside diameter at bending-strength ratio ^c				
		1.90	2.25	2.50	2.75	3.20
8 5/8 H 90	3	10 5/16	10 25/32	11 3/32	11 13/32	11 29/32
	3 1/4	10 9/32	10 3/4	11 1/16	11 3/8	11 7/8
	3 1/2	10 1/4	10 23/32	11 1/16	11 11/32	11 27/32
	3 3/4	10 7/32	10 11/16	11	11 5/16	11 13/16
2 3/8 PAC	1 1/4	2 51/64	2 57/64	2 31/32	3 1/32	3 5/32
	1 1/2	2 45/64	2 25/32	2 55/64	2 29/32	3 1/32
	1 3/4	2 17/32	2 19/32	2 21/32	2 11/16	2 25/32
2 7/8 PAC	1 1/4	3 3/64	3 5/32	3 15/64	3 5/16	3 7/16
	1 1/2	2 31/32	3 1/16	3 9/64	3 7/32	3 11/32
	1 3/4	2 27/32	2 59/64	3	3 3/64	3 5/32
3 1/2 PAC	1 1/2	3 11/16	3 53/64	3 15/16	4 1/32	4 13/64
	1 3/4	3 5/8	3 49/64	3 55/64	3 61/64	4 7/64
	2	3 33/64	3 41/64	3 47/64	3 13/16	3 61/64
2 3/8 OH	1 1/4	3 23/64	3 31/64	3 37/64	3 21/32	3 13/16
	1 1/2	3 5/16	3 27/64	3 33/64	3 19/32	3 47/64
	1 3/4	3 7/32	3 5/16	3 13/32	3 15/32	3 19/32
2 7/8 OH	1 1/2	3 55/64	4	4 1/8	4 13/64	4 3/8
	1 3/4	3 51/64	3 15/16	4 3/64	4 9/64	4 19/64
	2	3 45/64	3 27/32	3 15/16	4 1/64	4 11/64
3 1/2 OH	1 1/2	4 57/64	5 3/32	5 15/64	5 23/64	5 37/64
	1 3/4	4 7/8	5 1/16	5 3/16	5 5/16	5 17/32
	2	4 53/64	5 1/64	5 9/64	5 17/64	5 15/32
4 OH	2	5 49/64	6	6 11/64	6 5/16	6 37/64
	2 1/4	5 47/64	5 31/32	6 1/8	6 17/64	6 17/32
	2 1/2	5 43/64	5 29/32	6 1/16	6 13/64	6 29/64
4 1/2 OH	3 1/4	5 15/16	6 5/32	6 5/16	6 29/64	6 45/64
	3 1/2	5 13/16	6	6 5/32	6 9/32	6 33/64
	3 3/4	5 41/64	5 13/16	5 15/16	6 3/64	6 17/64

^a Labels are for information and assistance in ordering.

^b Minor differences between measured inside diameters and inside diameters in the tables are of little significance; therefore, use the inside diameter from the table that is closest to the measured inside diameter.

^c The effect of stress-relief features is disregarded in calculating bending-strength ratios.

Table D.13 — Drill-collar elevator groove and slip recess

Dimensions in inches

1	2	3	4	5	6	7
Drill-collar OD ranges	Elevator-groove depth l_e^a	Radius at top of elevator groove r_{EG}	Length elevator groove L_{eg} $+1$ 0	Slip-groove depth l_s^a	Radius at top of slip groove r_{SG}	Length of slip groove L_{sg} $+2$ 0
4 to 4 5/8	7/32	1/8	16	3/16	1	18
4 3/4 to 5 5/8	1/4	1/8	16	3/16	1	18
5 3/4 to 6 5/8	5/16	1/8	16	1/4	1	18
6 3/4 to 8 5/8	3/8	3/16	16	1/4	1	18
8 3/4 and larger	7/16	1/4	16	1/4	1	18
NOTE See Figure 16.						
^a l_e and l_s dimensions are from the nominal OD of a new drill collar.						

Table D.14 — Float-valve recess in bit subs

Dimensions in inches

1	2	3	4	5	6
Diameter of valve assembly ^a	Length of valve assembly	Label ^b rotary-shouldered connection	Length of float recess L_R $\pm 1/16$	Length of baffle-plate recess L_{br}	Diameter of float recess D_{FR} $+1/64$ 0
1 21/32	5 7/8	2 3/8 REG	9 1/8	3	1 11/16
1 21/32	5 7/8	NC23	9 1/8	3	1 11/16
1 29/32	6 1/4	2 7/8 REG	10	3	1 15/16
1 29/32	6 1/4	NC26	9 1/2	3	1 15/16
2 13/32	6 1/2	3 1/2 REG	10 1/2	3	2 7/16
2 13/32	6 1/2	NC31	10 1/4	3	2 7/16
2 13/16	10	3 1/2 FH	14	3	2 27/32
3 1/8	10	NC38	14 1/4	3	3 5/32
3 15/32	8 5/16	4 1/2 REG	12 13/16	3	3 1/2
3 15/32	8 5/16	NC44	13 1/16	3	3 1/2
3 21/32	12	NC46	16 3/4	3	3 11/16
3 7/8	9 3/4	5 1/2 REG	14 3/4	3	3 29/32
3 7/8	9 3/4	NC50	14 1/2	3	3 29/32
4 25/32	11 3/4	6 5/8 REG	17	3	4 13/16
4 25/32	11 3/4	5 1/2 IF	17	3	4 13/16
4 25/32	11 3/4	7 5/8 REG	17 1/4	3	4 13/16
4 25/32	11 3/4	5 1/2 FH	17	3	4 13/16
4 25/32	11 3/4	8 5/8 REG	17 3/8	3	4 13/16
4 25/32	11 3/4	NC61	17 1/2	3	4 13/16
5 11/16	14 5/8	8 5/8 REG	20 1/4	3	5 23/32
5 11/16	14 5/8	6 5/8 IF	19 7/8	3	5 23/32

NOTE See Figure 17.

^a The ID of the drill collar or sub and the ID of the bit pin shall be small enough to hold the valve.^b Labels are for information and assistance in ordering.

Table D.15 — Used bit-box and bit-bevel diameters

Dimensions in inches

1	2	3	4	5
Connection label ^a	Bit-sub diameter		Bit diameter	
	minimum	maximum ^b	minimum	maximum ^b
1 REG	1.452	1.484	1.484	1.516
1 1/2 REG	1.916	1.948	1.948	1.979
2 3/8 REG	3.031	3.063	3.062	3.094
2 7/8 REG	3 19/32	3 5/8	3 5/8	3 11/32
3 1/2 REG	4 3/32	4 1/8	4 1/8	4 5/32
4 1/2 REG	5 5/16	5 11/32	5 11/32	5 3/8
5 1/2 REG	6 31/64	6 33/64	6 33/64	6 35/32
6 5/8 REG	7 11/32	7 3/8	7 3/8	7 13/32
7 5/8 REG	8 29/64	8 31/64	8 31/64	8 33/64
8 5/8 REG	9 17/32	9 9/16	9 9/16	9 19/32

^a Labels are for information and assistance in ordering.

^b The maximum bevel diameters apply only to connections that have been re-faced in the field. They are not for use on newly manufactured products.

Table D.16 — API work-string tubing EUE-connections criteria

Dimensions in inches

Label ^a	Length (measured from end of pin) L_c	Coupling perfect thread length	Maximum power tight make-up	Minimum power tight make-up	Minimum coupling lengthH
1.050	0.300	1.025	1.875	2.325	3.250
1.315	0.350	1.150	1.950	2.450	3.500
1.660	0.475	1.275	2.075	2.575	3.750
1.900	0.538	1.338	2.138	2.638	3.875
2 3/8	0.938	1.813	2.688	3.188	4.875
2 7/8	1.125	2.000	2.875	3.375	5.250
3 1/2	1.375	2.250	3.125	3.625	5.750
4	1.500	2.375	3.250	3.750	6.000
4 1/2	1.625	2.500	3.375	3.875	6.250

^a Labels are for information and assistance in ordering.

Table D.17 — Tool-joint mass per foot for various OD/ID combinations

Dimensions in pounds per foot

OD in	Tool-joint mass per foot at ID in inches																											
	1 3/8	1 1/2	1 5/8	1 3/4	1 7/8	2	2 1/8	2 1/4	2 5/32	2 7/16	2 1/2	2 9/16	2 5/8	2 11/16	2 3/4	2 13/16	2 7/8	3	3 1/4	3 7/16	3 15/32	3 1/2	3 5/8	3 3/4	4	4 3/4	5	
2 7/8	17	16	15	—	—	—	—	—	—	—	—	—	—	—	—	—	—	—	—	—	—	—	—	—	—	—	—	—
3 1/8	21	20	19	18	17	15	14	13	—	—	—	—	—	—	—	—	—	—	—	—	—	—	—	—	—	—	—	—
3 3/8	—	24	23	22	21	20	19	18	17	—	—	—	—	—	—	—	—	—	—	—	—	—	—	—	—	—	—	—
3 1/4	26	22	21	20	19	18	16	15	16	—	—	—	—	—	—	—	—	—	—	—	—	—	—	—	—	—	—	—
3 3/4	—	32	30	29	28	27	25	24	25	22	21	20	19	18	17	16	15	14	9	6	—	—	—	—	—	—	—	—
3 7/8	—	—	—	32	31	29	28	27	28	24	23	23	22	21	20	19	18	16	12	9	—	—	—	—	—	—	—	—
4	—	—	—	35	33	32	31	29	30	27	26	25	24	23	23	22	21	19	15	11	—	—	—	—	—	—	—	—
4 1/8	—	—	—	—	—	35	33	32	33	30	29	28	27	26	25	24	23	21	17	14	—	—	—	—	—	—	—	—
4 1/4	—	—	—	—	—	38	36	35	36	32	32	31	30	29	28	27	26	24	20	17	—	—	—	—	—	—	—	—
4 3/8	—	—	—	—	—	40	39	38	39	35	34	34	33	32	31	30	29	27	23	20	—	—	—	—	—	—	—	—
4 1/2	—	—	—	—	—	43	42	41	42	38	37	37	36	35	34	33	32	30	26	23	—	—	—	—	—	—	—	—
4 5/8	—	—	—	—	—	46	45	44	45	41	40	40	39	38	37	36	35	33	29	26	—	—	—	—	—	—	—	—
4 3/4	—	—	—	—	—	50	48	47	48	44	44	43	42	41	40	39	38	36	32	29	—	—	—	—	—	—	—	—
4 7/8	—	—	—	—	—	53	51	50	51	48	47	46	45	44	43	42	41	39	35	32	31	—	—	—	—	—	—	—
5	—	—	—	—	—	56	55	53	54	51	50	49	48	47	47	46	45	43	39	35	35	35	—	—	—	—	—	—
5 1/8	—	—	—	—	—	—	—	—	58	54	53	53	52	51	50	49	48	46	42	39	38	—	—	—	—	—	—	—
5 1/4	—	—	—	—	—	—	—	—	61	58	57	56	55	54	53	52	52	50	45	42	41	—	—	—	—	—	—	—
5 3/8	—	—	—	—	—	—	—	—	65	61	60	60	59	58	57	56	55	53	49	46	45	—	—	—	—	—	—	—
5 1/2	—	—	—	—	—	—	—	—	—	65	64	63	62	61	61	60	59	57	53	49	49	—	—	—	—	—	—	—
5 5/8	—	—	—	—	—	—	—	—	—	69	68	67	66	65	64	63	62	60	56	53	52	—	—	—	—	—	—	—
5 3/4	—	—	—	—	—	—	—	—	—	72	72	71	70	69	68	67	66	64	60	57	56	56	53	—	—	—	—	—
5 7/8	—	—	—	—	—	—	—	—	—	76	75	75	74	73	72	71	70	68	64	61	60	60	59	57	—	—	—	—

Table D.17 (continued)

Dimensions in pounds per foot

OD in	Tool-joint mass per foot at ID in inches																											
	1 3/8	1 1/2	1 5/8	1 3/4	1 7/8	2	2 1/8	2 1/4	2 5/32	2 7/16	2 1/2	2 9/16	2 5/8	2 11/16	2 3/4	2 13/16	2 7/8	3	3 1/4	3 7/16	3 15/32	3 1/2	3 5/8	3 3/4	4	4 3/4	5	
6	—	—	—	—	—	—	—	—	—	80	79	79	78	77	76	75	74	72	68	65	64	63	61	—	—	—	—	—
6 1/8	—	—	—	—	—	—	—	—	—	84	83	82	81	80	80	79	78	76	72	69	68	67	65	63	—	—	—	—
6 1/4	—	—	—	—	—	—	—	—	—	88	87	86	85	84	84	83	82	80	76	73	72	72	69	67	—	—	—	—
6 3/8	—	—	—	—	—	—	—	—	—	93	92	91	90	89	88	87	86	84	80	77	76	76	73	71	—	—	—	—
6 1/2	—	—	—	—	—	—	—	—	—	97	96	95	94	94	93	92	91	89	85	81	81	81	80	78	75	—	—	—
6 5/8	—	—	—	—	—	—	—	—	—	101	101	100	99	98	97	96	95	93	89	86	85	84	82	80	—	—	—	—
6 3/4	—	—	—	—	—	—	—	—	—	106	105	104	103	102	101	101	100	98	93	90	90	89	87	84	—	—	—	—
6 7/8	—	—	—	—	—	—	—	—	—	110	110	109	108	107	106	105	104	102	98	95	94	93	91	89	—	—	—	—
7	—	—	—	—	—	—	—	—	—	115	114	113	112	112	111	110	109	107	103	99	99	98	96	93	—	—	—	—
7 1/8	—	—	—	—	—	—	—	—	—	120	119	118	117	116	115	114	113	112	107	104	103	103	100	98	—	—	—	—
7 1/4	—	—	—	—	—	—	—	—	—	124	123	122	122	121	120	119	118	116	112	109	108	108	105	103	—	—	—	—
7 3/8	—	—	—	—	—	—	—	—	—	129	128	127	127	126	125	124	123	121	117	114	113	113	110	108	—	—	—	—
7 1/2	—	—	—	—	—	—	—	—	—	134	134	133	132	131	130	129	128	126	122	119	118	117	115	113	107	90	—	—
7 5/8	—	—	—	—	—	—	—	—	—	139	138	137	137	136	135	134	133	131	127	124	123	123	120	118	113	95	—	—
7 3/4	—	—	—	—	—	—	—	—	—	145	144	143	142	141	140	139	138	136	132	129	128	128	125	123	118	100	—	—
7 7/8	—	—	—	—	—	—	—	—	—	150	149	148	147	146	145	144	144	142	137	134	133	133	130	128	123	105	—	—
8	—	—	—	—	—	—	—	—	—	—	—	—	—	—	—	—	—	—	—	—	—	138	136	133	128	111	104	—
8 1/8	—	—	—	—	—	—	—	—	—	—	—	—	—	—	—	—	—	—	—	—	—	—	—	139	134	116	110	—
8 1/4	—	—	—	—	—	—	—	—	—	—	—	—	—	—	—	—	—	—	—	—	—	—	—	—	144	139	121	115
8 3/8	—	—	—	—	—	—	—	—	—	—	—	—	—	—	—	—	—	—	—	—	—	—	—	—	—	145	127	121
8 1/2	—	—	—	—	—	—	—	—	—	—	—	—	—	—	—	—	—	—	—	—	—	—	—	—	—	150	133	126

Table D.18 — Drill-collar mass per foot at ID in inches

Dimensions in pounds per foot

OD in	Drill-collar mass per foot at ID in inches												
	1	1 1/4	1 1/2	1 3/4	2	2 1/4	2 1/2	2 13/16	3	3 1/4	3 1/2	3 3/4	4
2 7/8	19	18	16	—	—	—	—	—	—	—	—	—	—
3	21	20	18	—	—	—	—	—	—	—	—	—	—
3 1/8	23	22	20	—	—	—	—	—	—	—	—	—	—
3 1/4	26	24	22	—	—	—	—	—	—	—	—	—	—
3 3/4	35	33	32	—	—	—	—	—	—	—	—	—	—
3 1/2	30	29	27	—	—	—	—	—	—	—	—	—	—
3 5/8	32	31	29	—	—	—	—	—	—	—	—	—	—
3 3/4	35	33	32	—	—	—	—	—	—	—	—	—	—
3 7/8	37	36	34	—	—	—	—	—	—	—	—	—	—
4	40	39	37	35	32	29	—	—	—	—	—	—	—
4 1/8	43	41	39	37	35	32	—	—	—	—	—	—	—
4 1/4	46	44	42	40	38	35	—	—	—	—	—	—	—
4 3/8	48	47	45	43	40	38	—	—	—	—	—	—	—
4 1/2	51	50	48	46	43	41	—	—	—	—	—	—	—
4 5/8	—	—	51	49	46	44	—	—	—	—	—	—	—
4 3/4	—	—	54	52	50	47	44	—	—	—	—	—	—
4 7/8	—	—	57	55	53	50	47	—	—	—	—	—	—
5	—	—	61	59	56	53	50	—	—	—	—	—	—
5 1/8	—	—	64	62	59	57	53	—	—	—	—	—	—
5 1/4	—	—	68	65	63	60	57	—	—	—	—	—	—
5 3/8	—	—	71	69	66	64	60	—	—	—	—	—	—
5 1/2	—	—	75	73	70	67	64	60	—	—	—	—	—
5 5/8	—	—	78	76	74	71	68	63	—	—	—	—	—
5 3/4	—	—	82	80	78	75	72	67	64	60	—	—	—
5 7/8	—	—	86	84	81	79	75	71	68	64	—	—	—
6	—	—	90	88	85	83	79	75	72	68	—	—	—
6 1/8	—	—	94	92	89	87	83	79	76	72	—	—	—
6 1/4	—	—	98	96	94	91	88	83	80	76	72	—	—
6 3/8	—	—	103	100	98	95	92	87	84	80	76	—	—
6 1/2	—	—	107	105	102	99	96	92	89	85	80	—	—
6 5/8	—	—	111	109	107	104	101	96	93	89	84	—	—
6 3/4	—	—	116	113	111	108	105	101	98	93	89	—	—
6 7/8	—	—	120	118	116	113	110	105	102	98	93	—	—

Table D.18 (continued)

Dimensions in pounds per foot

OD in	Drill-collar mass per foot at ID in inches												
	1	1 1/4	1 1/2	1 3/4	2	2 1/4	2 1/2	2 13/16	3	3 1/4	3 1/2	3 3/4	4
7	—	—	125	123	120	117	114	110	107	103	98	93	88
7 1/8	—	—	130	127	125	122	119	114	112	107	103	98	93
7 1/4	—	—	134	132	130	127	124	119	116	112	108	103	98
7 3/8	—	—	139	137	135	132	129	124	121	117	113	108	103
7 1/2	—	—	144	142	140	137	134	129	126	122	117	113	107
7 5/8	—	—	149	147	145	142	139	134	131	127	123	118	113
7 3/4	—	—	154	152	150	147	144	139	136	132	128	123	118
7 7/8	—	—	160	157	155	152	149	144	142	137	133	128	123
8	—	—	165	163	160	157	154	150	147	143	138	133	128
8 1/8	—	—	170	168	166	163	160	155	152	148	144	139	134
8 1/4	—	—	176	174	171	168	165	161	158	154	149	144	139
8 3/8	—	—	181	179	177	174	171	166	163	159	155	150	145
8 1/2	—	—	187	185	182	179	176	172	169	165	160	155	150
9	—	—	210	208	206	203	200	195	192	188	184	179	174
9 1/4	—	—	222	220	218	215	212	207	204	200	196	191	186
9 1/2	—	—	235	233	230	227	224	220	217	213	208	203	198
9 3/4	—	—	248	246	243	240	237	233	230	226	221	216	211
10	—	—	261	259	256	253	250	246	243	239	234	229	224
10 1/2	—	—	288	286	284	281	278	273	270	266	262	257	252
11	—	—	317	315	312	310	306	302	299	295	290	286	280
11 1/2	—	—	347	345	342	340	336	332	329	325	320	316	310
12	—	—	378	376	374	371	368	363	360	356	352	347	342

Annex E (informative)

Inspection-level guidelines

E.1 Drilling equipment

The information listed below is for use as a relative guideline in selecting the level of inspection appropriate to the operating environment. Operating experience shall be considered in the quality ranking process. In deciding on the level of inspection, the higher costs of inspection associated with moderate or critical service inspection should be considered. Inspections that require measurement and recording of measurements add substantially to the cost of inspection versus a “go/no-go” check to provide assurance that the element meets established requirements.

Table E.1 — Inspection levels

Inspection level	Loads % of capacity	Project risk	Operating life
Standard	< 40	Low	Short
Moderate	40 to 70	Medium	Standard
Critical	> 70	High	Long
Extreme	> 80	Very high	Very long

E.2 Standard inspection

E.2.1 Operational environment

The following operating-environment conditions typically require a standard inspection:

- corrosivity: drilling fluid is OBM or SOBM (low-corrosive environment) and the drilling is not under-balanced;
- abrasiveness: soft, non-abrasive formations;
- fatigue: low vibration, low dogleg severities [i.e. less than 2,0°/30,5 m (100.0 ft)], side-load forces below 59,6 kg/m (40 lb/ft), low anticipated rotary speeds of less than 120 r/min, no back-reaming;
- mud weight: below 1,44 kg/l (12,0 lb/gal).

E.2.2 Loads

The following load conditions typically require a standard inspection:

- tension: expected maximum load not exceeding 40 % of the inspected class rating;
- torque: expected maximum load not exceeding 40 % of the make-up torque;
- jarring: no jarring of the drill pipe or jars expected.

E.2.3 Project risk

The following project risk conditions would typically require a standard inspection:

- rig costs: low rig costs generally associated with standard land drilling rigs;
- environmental: rigorous environment with low possibility of risk to wildlife and public;
- critical process: non-critical stage or process in the operation of the well; recovery from failure is probable and not costly.

E.2.4 Cumulative rotating hours between inspections

The number of cumulative rotating hours between inspections is less than 100 h for equipment that is not considered a high-stress component. (Examples of high-stress drill stem elements include stabilizers, bottleneck crossovers, bent mud motors.)

E.3 Moderate inspection

E.3.1 Operating environment

The following operating-environment conditions typically require a moderate inspection:

- corrosivity: drilling fluid is WBM (moderately corrosive environment) and drilling is not under-balanced;
- abrasiveness: moderately abrasive formations;
- fatigue: moderate vibration, moderate dogleg severities [i.e. 2,0° to 4,0°/30,5 m (100.0 ft)], side-load forces between 59,6 kg/m and 89,3 kg/m (40 lb/ft and 60 lb/ft), moderate anticipated rotary speeds (120 r/min to 150 r/min), some back-reaming;
- mud weight: between 1,44 kg/l and 1,92 kg/l (12,0 lb/gal and 16,0 lb/gal).

E.3.2 Loads

The following load conditions would typically require a moderate inspection:

- tension: expected maximum load between 40 % and 70 % of the inspected class rating;
- torque: expected maximum load between 40 % and 70 % of the make-up torque;
- jarring: little jarring of the drill pipe or jars expected.

E.3.3 Project risk

The following project risk conditions typically require a moderate inspection:

- rig costs: moderate rig costs generally associated with standard shelf drilling rigs;
- environmental: moderate environment with low possibility of risk to wildlife and public;
- critical process: important stage or process in the operation of the well; recovery from failure is probable and not costly.

E.3.4 Cumulative rotating hours between inspections

The number of cumulative rotating hours between inspections is between 100 h and 200 h.

E.4 Critical inspection

E.4.1 Operating environment

The following operating-environment conditions typically require a critical inspection:

- corrosivity: drilling fluid is brine or SWBM (corrosive environment) or an influx of formation fluid is probable;
- abrasiveness: hard or abrasive formations;
- fatigue: high vibration, high dogleg severities [$> 4,0^\circ/30,5$ m (100,0 ft)], side-load forces greater than 89,3 kg/m (60 lb/ft), high anticipated rotary speeds (> 150 r/min), back-reaming probable;
- mud weight: greater than 1,92 kg/l (16,0 lb/gal).

E.4.2 Loads

The following load conditions would typically require a critical inspection:

- tension: expected maximum load exceeding 70 % of the inspected class rating;
- torque: expected maximum load exceeding 70 % of the make-up torque;
- jarring: jarring of the drill pipe or jars expected.

E.4.3 Project risk

The following project risk conditions typically require a critical inspection:

- rig costs: high rig costs generally associated with deep-water drilling rigs;
- environmental: fragile environment with a high possibility of risk to wildlife and public;
- critical process: critical stage or process in the operation of the well; recovery from failure is not probable and/or very costly.

E.4.4 Cumulative rotating hours between inspections

The number of cumulative rotating hours between inspections is greater than 300 h.

E.5 Additional services for extreme service

E.5.1 Operating environment

The following operating-environment conditions typically require additional services for extreme service:

- corrosivity: drilling fluid is brine or SWBM (corrosive environment) or an influx of formation fluid is probable;
- abrasiveness: very hard and abrasive formations, salt formations;
- fatigue: high vibration, high dogleg severities [$> 10,0^\circ/30,5$ m (100 ft)], side-load forces greater than 119,1 kg/m (100 lb/ft), high anticipated rotary speeds (> 180 r/min), back-reaming necessary;
- mud weight: greater than 2,16 kg/l (18,0 lb/gal).

E.5.2 Loads

The following load conditions typically require additional services for extreme services:

- tension: expected maximum load exceeding 80 % of the inspected class rating;
- torque: expected maximum load exceeding 80 % of the make-up torque;
- buckling: no buckling of the drill pipe or jars expected;
- jarring: jarring of the drill pipe or jars expected and necessary.

E.5.3 Project risk

The following project risk conditions typically require additional services for extreme service:

- rig costs: high rig costs generally associated with deep-water drilling rigs;
- environmental: fragile environment with a high possibility of risk to wildlife and public;
- critical process: critical stage or process in the operation of the well; recovery from failure is not probable and/or very costly.

E.5.4 Cumulative rotating hours between inspections

The number of cumulative rotating hours between inspections is greater than 500 h.

Annex F (informative)

Proprietary drill stem connection inspection

F.1 General

There are several manufacturers who produce and sell proprietary connections. Most of these proprietary connections can be grouped into two categories:

- a) double shoulder;
- b) non-shouldering dovetail-thread-form connections.

In general, these connections derive their torsional strength from features or characteristics not found in conventional rotary-shoulder connections. In addition, some of these proprietary connections have additional features not available on conventional rotary-shouldered connections (such as radial metal-to-metal seals). Because of these characteristics, the inspections covered in the body of this part of ISO 10407 might not apply or be adequate for proprietary connections.

In general, the inspection of these proprietary connections is not specific to the component. However, since these connections are most often found on drill-pipe tool joints, this annex is written specifically for tool-joint inspection. When inspected on tools other than drill pipe, the inspection of some features might not be applicable.

Because the manufacturers manage these connections, their specifications are subject to change without notice. For this reason, the current inspection procedures, dimensions and acceptance criteria shall be obtained from the manufacturer prior to the inspection. This annex describes only the additional inspections that the manufacturers typically recommend.

F.2 Double shoulder connections

F.2.1 General

Double-shoulder connections have a tapered thread with load shoulders at both ends of the threaded section. In addition to the conventional external shoulder located at the base of the pin and box face, there is an internal shoulder at the pin nose and the back of the box. Typically, only the external shoulder is designated to be a sealing shoulder.

A critical feature of these double-shoulder connections is the length of the pin and corresponding depth of the box. These lengths and their tolerances are critical in the performance of these connections. A thorough inspection requires measurement of these features in addition to the measurements made on conventional rotary-shoulder connections.

In addition to the pin length and box depth, the thread form and taper can differ from conventional rotary-shoulder connections. This can require unique thread-profile gauges, lead-gauge ball inserts and lead-gauge setting standards, as well as other inspection instruments. It is necessary that the manufacturer of the connection be consulted to determine whether any of these unique inspection tools is needed and, if so, how it may be obtained.

F.2.2 Visual inspection

F.2.2.1 General

The visual inspection procedures for drill-pipe tool joints detailed in 10.14 generally apply to the double-shoulder connections. Clause F.2 describes only the additional inspections applicable to the double-shoulder connections.

F.2.2.2 Internal shoulder

The internal shoulder at the pin nose is usually not a sealing shoulder and, because of rig handling, can have dents or gouges that do not affect performance. Provided these dents or gouges do not result in raised material that can affect the length of the pin, the manufacturer may consider these acceptable. Some manufacturers may permit slight filing to remove areas of raised metal on the pin nose. For both of these cases, the manufacturer has guidelines for the acceptance of damage to the pin nose.

The same criteria apply to the internal shoulder at the back of the box. Since it is protected, this shoulder is typically not subject to handling damage. Damage is possible, however, so this shoulder shall also be examined for damage that can produce areas of raised metal that affect the length of the box.

Connections that have the rejectable damage to the external shoulder described in 10.14.8.1.2 or 10.14.8.1.3 or rejectable damage to the internal shoulder shall be removed from service. The manufacturer may allow for re-facing to repair this damage. The equipment and corresponding procedures used shall preserve the critical length relationship between the two shoulders. Because of this, refacing shall not be attempted without the equipment and procedures specified by the manufacturer.

F.2.2.3 Thread surfaces

The inspection of the thread surfaces are generally in accordance with 10.14.8.2. The manufacturer may have different tolerances for protrusions, cuts and gouges. Before accepting or repairing any of this type of damage, the manufacturer's inspection procedure should be reviewed to be sure that such a condition or such a repair is acceptable. Galling is generally unacceptable on the thread surfaces of all double shoulder connections.

F.2.2.4 Thread profile and lead measurement

Proprietary connections may have thread profiles and leads that differ significantly from the more common connections. If this is the case, it is necessary that the manufacturer of the connection be contacted for the proper standards. Lead tolerances are specified by the manufacturer.

F.2.3 Dimensional measurements

F.2.3.1 General

The box outside diameter, pin inside diameter, shoulder width, box counterbore, bevel diameter and tong-space measurements are made in the same manner as described in 10.18 and 10.19. The location where the measurements are taken may vary from those of the standard API connections. Consult the manufacturer's procedures before taking these measurements. It is necessary that the acceptable dimensions be specified by the manufacturer.

F.2.3.2 Pin and box connection length

The distance between the exterior shoulder and the interior shoulder and the tolerances for these dimensions are established by the manufacturer. Typically, there is a slight difference in the acceptable range for the pin and box connection length.

Using a long-stroke depth micrometer, measure the distance between the exterior shoulder and the interior shoulder and record the values on the inspection work sheet for both the pin and box connection.

Measurements outside the acceptable range shall be cause for rejection. Re-facing may be an acceptable method to repair this but, as mentioned in Clause F.2, it is necessary to contact the manufacturer for the proper equipment and procedures for re-facing.

F.2.3.3 Pin-nose diameter

Measurement of the pin-nose diameter is required on some double-shouldered connections. This measurement is to detect nose swell.

Using a dial/digital calliper or micrometer, check the diameter near the centre of the flat section of the pin nose. Measurements outside the acceptable range shall be reported on the work sheet. Pin-connection length is the governing factor for acceptance.

F.2.3.4 Pin-base diameter

Pin-base diameter may be specified with tolerances on the manufacturer's field inspection drawings or procedures. It is not normally a required measurement on used connections. If required by the owner/user, use a dial/digital calliper or micrometer to measure the diameter and record the values on the inspection work sheet.

F.2.3.5 Redoping connection

Doping procedures for proprietary double-shouldered connections are different from those for conventional rotary-shouldered connections where there is no secondary shoulder. For double-shouldered connections, it is important that the interior shoulder at the bottom of the box as well as the nose of the pin are thoroughly cleaned and doped prior to make-up of the connection. This can be particularly difficult when pulling out of the hole when there is a plugged bit, or when slugging the string with fresh water is not allowed. When these difficulties are encountered, the best results are achieved when cleaning and doping activities are performed while running in the hole. Also for double-shouldered connections, it is important that the correct amount of thread compound be applied. Insufficient amounts cause steel-to-steel contact and excessive amounts can cause interference as the connection is made up that can result in false torque readings. A paint brush is often recommended for use in applying thread compound to double-shouldered connections as opposed to the conventional bristle brush.

F.2.4 Non-shouldering dovetail-thread-form connections

F.2.4.1 General

The non-shouldering dovetail-thread-form connection utilizes a tapered thread where thread interference provides the torque resistance for make-up rather than shoulder contact. The seal is provided by thread interference and the lubricant. Because of this, design damage to the pin face, pin external shoulder, box face and box internal shoulder can be hand-dressed to remove protrusions.

F.2.4.2 Equipment

Equipment includes a telescope gauge and dial/digital micrometer (or inside-diameter micrometer).

F.2.4.3 Inspection procedures

F.2.4.3.1 General

The current non-shouldering dovetail-thread-form-type of drill-pipe tool-joint connection is a rugged connection and not as susceptible to field damage as most connections. Unlike conventional shouldering tool joints, the dovetail thread creates a seal in the tapered thread of the small step rather than on the external shoulder. Because the threads create the seal, damage to the pin external shoulder or box face does not require re-facing or rejection of the joint. Typical running and handling damage to the dovetail thread can be field-repaired. Damage to the pin face, pin external shoulder, box face and box internal shoulder can be hand

dressed to remove any protrusion that can interfere with the make-up of the mating threads. Shoulders should not be re-faced.

Repair threads as needed. The thread surface can be dressed with a file or hand grinder and then wiped clean. The thread flanks, roots and crests should have a relatively even surface.

Inspect threads for the following.

- Dents and mashed areas: The damage raises metal above the original surface and interferes with the full engagement of pin and box; it shall be removed with a file or hand grinder.
- Excessive galling and scoring: Galling that wipes out threads or that cannot be dressed using a file or hand grinder prevents proper thread engagement and is excessive.
- Excessive out-of-roundness: Out-of-roundness prevents proper stabbing. A connection that is exceedingly out-of-round cannot stab deeply and develops torque prematurely.
- Excessive rust or scale: Build-up of corrosion products prevents the proper make-up of pin and box and should be removed. This can be done with a wire brush. Small pits and other local metal-loss corrosion does not interfere with the proper make-up or sealing and are not cause for rejection. However, the surface should be free of pits and other surface imperfections that exceed 1,5 mm (0.06 in) in depth and 3,18 mm (0.125 in) in diameter or extend more than 38 mm (1.5 in) in length along the thread helix.
- Thread protrusions: Any burrs, raised corners, or other damage projecting outward from the thread surface should be hand-dressed until the surface is even.

The current non-shouldering dovetail-thread-form tool-joint-connection inspection procedure allows drilling crews to determine whether the connection warrants repairs. The rugged design permits field repairing most of the damage encountered by the dovetail thread, a repair procedure that is less expensive and time consuming than re-cutting the tool joint.

F.2.4.3.2 Visual inspection

Examine the shoulder for evidence of shoulder-to-shoulder contact, such as scoring, deformation or burnish patterns. If there is indication of shoulder-to-shoulder engagement, the thread shall be rejected.

The current non-shouldering dovetail-thread-form connection is designed with a wear indicator gap between the box face and the external shoulder of the pin. This gap eliminates the reaction surface found in the torque shoulder of conventional tool joints. However, after repetitive make-up and break-out operations, the thread flanks wear permitting additional travel of the pin into the box. This leads to a smaller gap at the external shoulder and, eventually, an engagement between the face of the box and the thread-wear indicator projecting from the pin shoulder. The protruding shape of the thread-wear indicator is designed such that it deforms sufficiently to show adequate signs of a nearly worn out connection. The purpose of the indicator is to provide an allowance of several make-and-breaks before the connection is fully worn out, and ultimately indicating when the connection should be re-cut. When the connection is fully worn out, there is full contact between the external pin shoulder and the face of the box. After the thread-wear indicator contacts the box face, the connection should be re-cut.

Inspectors should check for

- deformation on the wear indicator,
- scoring marks on the pin shoulder or box face,
- burnish patterns on the pin shoulder or box face, and
- gap closure.

If any of the above indications is found on either the box or the pin end, then that end should be re-cut.

Examine the shoulder for damage that causes protrusions; these may be removed by hand-dressing. Shoulders should not be refaced.

Examine the thread surfaces for protrusions above the normal thread surface. Pay particular attention to areas of dents and meshes. Protrusions shall be dressed until the surface is even or the connection shall be rejected.

Build-up of rust or scale can prevent proper make-up of the pin and box and should be removed. This can be done with a wire brush. Small pits and metal loss do not interfere with proper make-up and sealing and are not cause for rejection. Pits deeper than 1,58 mm (0.062 5 in) in depth, or 3,17 mm (0.125 in) in diameter, or extending more than 37,1 mm (1.5 in) along the helix are cause for rejection.

Minor galling is permissible if it can be dressed using a hand file or grinder. Other galling shall be rejected.

Out-of-roundness that interferes with stabbing shall be cause for rejection.

Rejected threads may be recut.

F.2.4.3.3 Bevel diameter

The bevel shall be present all the way around the connection. Because the bevel diameter is an OD wear indicator, it shall not be modified. The bevel diameter provides an indication of tool-joint OD wear. The tool joint retains full rated tension and torque strength with OD wear down to the bevel diameter. Allowance shall be made for adequate tool-joint OD wear to extend the life of the string.

If hard-banding is present, a smaller initial tool-joint OD may be used. Often, the OD of the hard-banding is larger (proud) than the tool-joint OD. The proud hard-banding absorbs the wear during drilling. When the hard-banding is reduced to the tool-joint OD, the hard-banding should be rebuilt. With this system, the proud hard-banding replaces the wear allowance of large-OD tool joints.

F.2.4.4 Box internal-diameter measurement

Using a telescope gauge and dial/digital callipers or inside-diameter micrometer, measure the counterbore diameter and the diameter of the flat section behind the large thread in the box. The manufacturer specifies a maximum diameter for each of these measurements. If the measurement exceeds this value at any place, the connection shall be rejected.

F.2.4.5 Thread compound

Because these threads seal in conjunction with the thread compound, the compound used shall meet the thread-manufacturer's requirements. Compounds containing solids are required. Zinc tool-joint compounds and copper/graphite tool-joint compounds are commonly recommended.

Compounds shall be applied evenly over all pin-thread surfaces. It is not necessary to apply compound to the box threads for make-up.

Annex G (informative)

Used work-string tubing proprietary-connection thread inspection

G.1 Scope

There are several manufacturers who produce and sell proprietary connections that are used in tubing work strings. These proprietary connections can have several features or characteristics that are used to distinguish them and the way they function. These features include sealing threads, non-sealing threads, dovetail thread form, metal-to-metal seals, shoulders and seal-ring grooves. Because of these characteristics, the inspections covered in the body of this part of ISO 10407 might not apply or be adequate for proprietary connections.

Because the manufacturers manage the proprietary connections, their specifications are subject to change without notice. For this reason, the current inspection procedures, dimensions and acceptance criteria shall be obtained from the manufacturer prior to the inspection. This annex describes only the additional inspections that the manufacturers typically recommend.

G.2 All threads

Any protrusion on a thread flank, root or crest throughout the pin and box thread length that extends into the space reserved for the mating connection shall be repaired or shall be cause for rejection. Connections that are obviously out-of-round or have excessive rust or scale or missing threads shall be rejected. Galled threads shall be rejected. Repairs shall be made only by agreement between the agency and the owner/operator. Generally, repairs are restricted to non-sealing threads, or are done by an authorized representative of the thread manufacturer.

G.3 Sealing threads

Sealing threads provide a seal by interference fit of the mating surfaces, along with the hoop stresses associated with the make-up of a tapered thread maintaining a high-contact pressure. Any designed gaps in the thread form as mated are closed by the thread compound and the helical path around the threads.

Because of the interference fit, any leak path associated with thread design has a long helical path. Any imperfection that breaks the continuity of the thread and provides a leak path along the axis of the thread is cause for rejection, and is only repairable by re-cutting the thread. Imperfections that break the continuity of the threads include, but are not limited to, pits, cuts, dents, chatter, grinds, broken threads, non-full-crested threads and galling. Minor surface roughness might not be detrimental but the manufacturer should be consulted for questionable imperfections.

G.4 Dovetail-thread-form connections

The non-shouldering dovetail-thread-form connection utilizes a tapered thread where thread interference rather than shoulder contact provides the torque resistance for make-up. The seal is provided by thread interference and the lubricant. Because of this, design damage to the pin face, pin external shoulder, box face and box internal shoulder can be hand-dressed to remove protrusions. Dents and mashes typically may be field-dressed so they do not interfere with make-up.

G.5 Metal-to-metal seals

Metal-to-metal seals are utilized in a number of different places on proprietary connections. The manufacturer's literature and inspection procedures provide information concerning the exact location of the seals on each particular connection.

Metal-to-metal seals shall be free of longitudinal cuts and scratches across the seal. There shall be no burrs, corrosion, rust, galling or scale on the seal surfaces. There shall be no dents or mashes of the seal surfaces. All the above conditions shall be cause for rejection of the connection.

Premium tubing thread connections with metal-to-metal seals and/or torque-stops are subject to damage such as box swelling and/or pin-nose deformation. This is the result of over-torquing the connection and the metal-to-metal seals/torque stops yielding. Special attention shall be given to the seals and torque stops when performing a visual inspection on this type of connection.

G.6 Shoulders

Shoulders that also function as seals shall be inspected as seals, in addition to the criteria for shoulders.

External shoulders, internal shoulders at the pin nose, internal shoulders at the small end of the box and any intermediate shoulders are usually not sealing shoulders on tubing connections. Because of rig handling, shoulders can have dents or gouges that do not affect performance, provided these dents or gouges do not result in raised material that affects the length of the pin or the ability to make up. The manufacturer may consider these acceptable. Some manufacturers may permit slight filing to remove areas of raised metal on the pin nose. For both of these cases, the manufacturer has guidelines for the acceptance of damage to the pin nose.

Connections that have rejectable damage to the external shoulder or rejectable damage to the internal shoulder shall be removed from service. The manufacturer may allow repair of this kind of damage.

G.7 Seal-ring grooves

Seal-ring grooves shall not show evidence of corrosion or scale. Seal-ring grooves shall not show evidence of mechanical damage that can interfere with the insulation or proper seating of the seal ring.

Bibliography

- [1] ISO 11484, *Steel products — Employer's qualification system of non-destructive testing (NDT) personnel*
- [2] API Spec Q1/ISO/TS 29001, *Specification for Quality Programs for the Petroleum, Petrochemical and Natural Gas Industry*
- [3] ASNT SNT-TC-1A, *Recommended Practice — Non-Destructive Testing*
- [4] ISO 9000, *Quality management systems — Fundamentals and vocabulary*
- [5] ISO 10407-1²⁾, *Petroleum and natural gas industries — Rotary drilling equipment — Part 1: Drill stem design and operating limits*
- [6] ISO 10424-2, *Petroleum and natural gas industries — Rotary drilling equipment — Part 2: Threading and gauging of rotary shouldered thread connections*
- [7] API Spec 7, *Specification for Rotary Drill Stem Elements*, Fortieth Edition
- [8] API Spec 7-1/ISO 10424-1, *Specification for Rotary Drill Stem Elements*
- [9] API Spec 7-2, *Rotary Drilling Equipment — Part 2: Threading and Gauging of Rotary Shouldered Thread Connections*
- [10] ASTM E1220, *Standard Test Method for Visible Penetrant Examination Using the Solvent-Removable Process*

2) To be published. (Revision, together with this part of ISO 10407, of ISO 10407:1993)

