**Textile floor coverings — Production
of changes in appearance by means of
Vettermann drum and hexapod tumbler
tester**

*Revêtements de sol textiles — Production de changements d'aspect au
moyen d'essais au tambour Vettermann et au tambour pour hexapode*





COPYRIGHT PROTECTED DOCUMENT

© ISO 2012

All rights reserved. Unless otherwise specified, no part of this publication may be reproduced or utilized in any form or by any means, electronic or mechanical, including photocopying and microfilm, without permission in writing from either ISO at the address below or ISO's member body in the country of the requester.

ISO copyright office
Case postale 56 • CH-1211 Geneva 20
Tel. + 41 22 749 01 11
Fax + 41 22 749 09 47
E-mail copyright@iso.org
Web www.iso.org

Published in Switzerland

Contents

Page

Foreword	iv
Introduction	v
1 Scope	1
2 Normative references	1
3 Terms and definitions	1
4 Principle	1
5 Method A — Vettermann drum method	1
5.1 Apparatus	1
5.2 Atmosphere for conditioning and testing	4
5.3 Selection and preparation of test specimens	4
5.4 Procedure	5
6 Method B — Hexapod method	5
6.1 Apparatus	5
6.2 Atmosphere for conditioning and testing	7
6.3 Selection and preparation of test specimens	8
6.4 Procedure	8
7 Test report	9

.....

Foreword

ISO (the International Organization for Standardization) is a worldwide federation of national standards bodies (ISO member bodies). The work of preparing International Standards is normally carried out through ISO technical committees. Each member body interested in a subject for which a technical committee has been established has the right to be represented on that committee. International organizations, governmental and non-governmental, in liaison with ISO, also take part in the work. ISO collaborates closely with the International Electrotechnical Commission (IEC) on all matters of electrotechnical standardization.

International Standards are drafted in accordance with the rules given in the ISO/IEC Directives, Part 2.

The main task of technical committees is to prepare International Standards. Draft International Standards adopted by the technical committees are circulated to the member bodies for voting. Publication as an International Standard requires approval by at least 75 % of the member bodies casting a vote.

Attention is drawn to the possibility that some of the elements of this document may be the subject of patent rights. ISO shall not be held responsible for identifying any or all such patent rights.

ISO 10361 was prepared by Technical Committee ISO/TC 219, *Floor coverings*.

This second edition cancels and replaces the first edition (ISO 10361:2000), which has been technically revised.

iv

Introduction

This International Standard describes two instruments used for fatiguing textile floor covering specimens and the production of changes in appearance in laboratory simulation of wear. This document was originally published as a type 2 Technical Report. ISO/TC 219 then decided to revise the document in order to publish it as an International Standard.

.....

Textile floor coverings — Production of changes in appearance by means of Vettermann drum and hexapod tumbler tester

1 Scope

This International Standard describes procedures for using the Vettermann drum tester and the hexapod tumbler tester to produce changes in appearance for all textile floor coverings due to changes in surface structure and colour produced by mechanical agencies. It does not include pilling or colour changes due to other agencies.

Changes produced by these drum testers are assessed in accordance with the applicable assessment standard.

2 Normative references

The following referenced documents are indispensable for the application of this document. For dated references, only the edition cited applies. For undated references, the latest edition of the referenced document (including any amendments) applies.

ISO 139, *Textiles — Standard atmospheres for conditioning and testing*

ISO 868, *Plastics and ebonite — Determination of indentation hardness by means of a durometer (Shore hardness)*

ISO 1957, *Machine-made textile floor coverings — Selection and cutting of specimens for physical tests*

ISO 2424, *Textile floor coverings — Vocabulary*

ISO 9405, *Textile floor coverings — Assessment of changes in appearance*

ISO 7619-1:2010, *Rubber, vulcanized or thermoplastic — Determination of indentation hardness — Part 1: Durometer method (Shore hardness)*

3 Terms and definitions

For the purposes of this document, the terms and definitions given in ISO 2424 apply.

4 Principle

A steel ball or a hexapod with studs rolls randomly inside a rotating drum which is lined with the textile floor covering specimens.

After fatiguing, the change in appearance of the specimens is assessed in accordance with the applicable assessment standard.

5 Method A — Vettermann drum method

5.1 Apparatus

5.1.1 Vettermann drum tester, with a metal drum of the following dimensions (see Figure 1):

- internal diameter: (730 ± 10) mm;
- internal depth: (270 ± 5) mm;

ISO 10361:2012(E)

- effective depth: (240 ± 7) mm;
- thickness of curved surface: $(8 \pm 0,5)$ mm.

The drum shall be capable of rotating at a speed of $(0,266 \pm 0,016)$ rad s⁻¹ [(16 ± 1) rev/min] and shall have facilities for reversing the direction of rotation every 5 min with approximately 1 s stationary time. The drum system shall incorporate a revolution counter, and specimens shall be held in place by four adjustable retaining segments (thickness $15 \text{ mm} \pm 1 \text{ mm}$) on each side wall of the drum.

Loose pile fibres shall be removed by means of a free-running brush mounted so as to be in light contact with the surface of the specimens, and the fibres extracted by a vacuum cleaner. Figure 1 illustrates the drum in cross-section.

A vulcanized-fibre backing sheet of size $2\,320 \text{ mm} \times 270 \text{ mm} \times 1,5 \text{ mm}$ thick and of density $1,1 \text{ g/cm}^3$ to $1,3 \text{ g/cm}^3$ at $20 \text{ }^\circ\text{C}$ is loosely laid inside the drum shell on the working side.

The sheet remains permanently in the drum.

5.1.2 Steel ball, fitted with 14 cylindrical rubber studs located so as to be equally spaced on the ball surface. The studs shall be replaceable and screwed into flat faces machined into the surface of the ball (see Figure 2).

Diameter of the ball:	$(120 \pm 0,2)$ mm
Distance between diametrically opposed flat stud-mounting faces:	$(118 \pm 0,1)$ mm
Mass without studs:	$(6\,800 \pm 100)$ g
Mass with 14 studs:	$(7\,600 \pm 100)$ g

Each stud shall consist of a light grey natural rubber disc attached to a steel backing plate having an integral mounting screw.

Specification of the studs:

Thickness of metal plate:	3 mm	
Diameter:	$(40 \pm 0,5)$ mm	
Height (without spiral drill):	$(15 \pm 0,5)$ mm	Spiral drill: Metric 8
Hardness of studs:	Shore A (47 ± 3) measured according to ISO 7619-1:2010, reading after 3 s	

After each test, replace two opposite studs with new ones.¹⁾ The two studs that have been used longest shall be replaced first. The studs shall be stored in a dark room at between $18 \text{ }^\circ\text{C}$ and $23 \text{ }^\circ\text{C}$, but not longer than 18 months.

5.1.3 Vacuum cleaner, having a width of suction head at least equal to the width of the specimens.

1) Replacement studs for the Vettermann drum tester can be obtained from:

— Artech Rubber BV Ijslandsestraat 8 7202 CL Zutphen Netherlands (info@artechrubber.nl).

— TFI Charlottenburger Allee 41 52068 Aachen Germany postmaster@tfi-online.de Studs can be tested by: Elastomer Research Testing BV PO box 2149 7420 AC Deventer Netherlands (info@ertbv.nl).

This information is given for the convenience of users of this International Standard and does not constitute an endorsement by ISO of the product named. Equivalent products may be used if they can be shown to lead to the same results.

Dimensions in millimetres

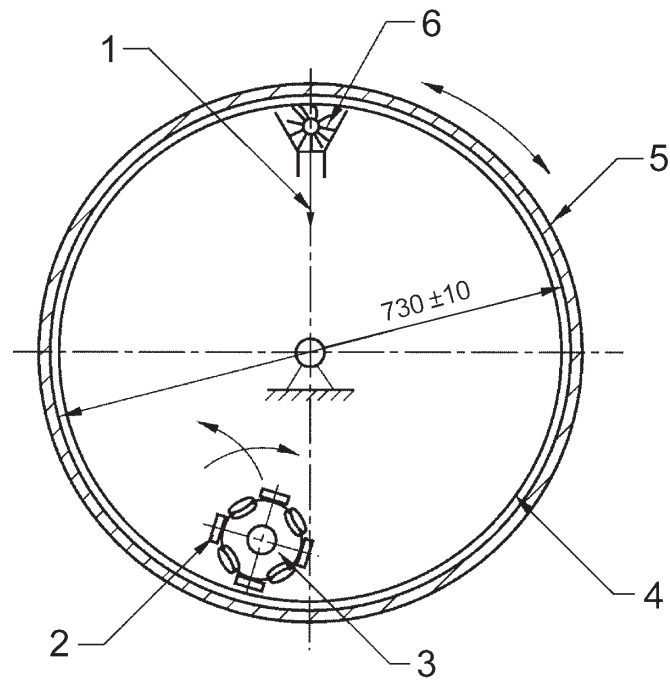

Key

- 1 extraction of brushed fibres
- 2 rubber stud
- 3 steel ball
- 4 vulcanized-fibre backing sheet
- 5 metal drum
- 6 circular brush

Figure 1 — Vettermann drum tester

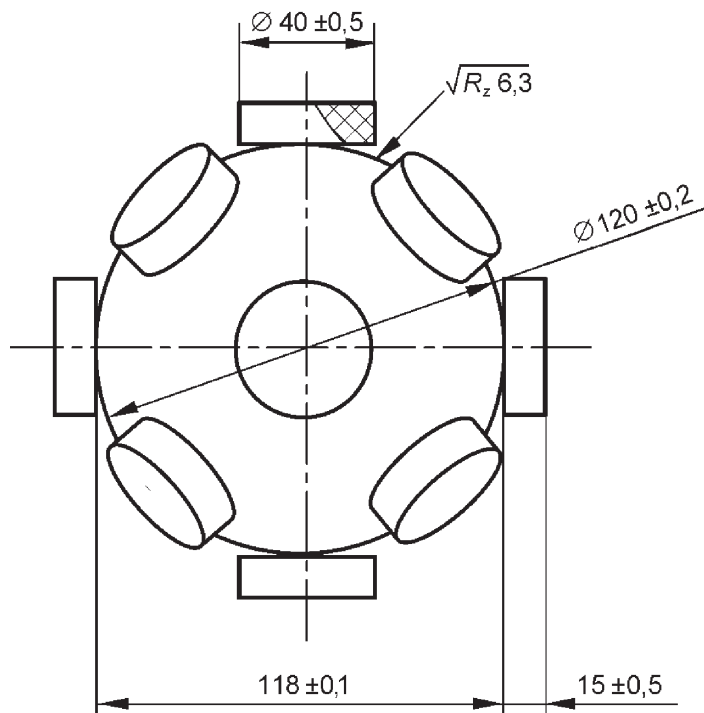

Figure 2 — Steel ball

5.2 Atmosphere for conditioning and testing

Use an atmosphere of relative humidity (65 ± 4 %), and of temperature (20 ± 2) °C, in accordance with ISO 139, for both conditioning and testing.

5.3 Selection and preparation of test specimens

5.3.1 Selection

Select the specimens in accordance with ISO 1957 to be as representative as possible of the bulk. Before cutting out the test specimens, mark the sample and each test specimen on the back with an arrow set in the direction of pile lay.

Colour and design may play a large part in the assessment of appearance retention, and this should be borne in mind when selecting specimens.

5.3.2 Number and dimensions

Cut out a sufficient number of specimens so as to be able to line the inside of the drum completely. Specimens shall measure at least 450 mm long in the direction of manufacture by 265 mm wide. Cut a similarly sized and positioned specimen for comparison purposes.

Provided that there is no fibre or finish transfer, for production control purposes, specimens from up to four different samples of similar thickness may be tested at the same time.

For materials with a pronounced direction of pile lay, specimens shall be tested in both machine and cross-machine direction.

5.3.3 Preparation

The test specimens and the specimen for comparison shall be cleaned as described in 5.4 with the upright vacuum cleaner (5.1.3) and left to condition flat, singly, pile uppermost for at least 24 h. If fraying of the edge occurs during testing, apply adhesive tape to the edges of the specimens.

5.4 Procedure

Fit the specimens into the drum (5.1.1), with the use surface towards the centre of the drum and the edges under the retaining segments. Ensure that the ends of the specimens lie near the centre of the retaining segments and clamp firmly.

If required, non-foam backed textile floor coverings may be tested over an underlay by mounting the underlay in the drum (5.1.1) prior to fitting the specimens into the drum as described above.

Test results apply only to the combination of carpet and specific underlay. They are not valid for combinations with other underlays. For identification of the underlay used it is recommended to give the following details: material, mass per unit area and thickness.

Check that the ball (5.1.2), together with its studs, is clean and free from any contamination. If necessary, wipe it over with ethanol using a clean tissue and place the ball in the drum. Preset the revolution counter for either the long run test, to simulate long-term use in a heavy-wear situation, or the short run test, to simulate early changes in appearance in less severe wear sites. Then switch the machine on to start the test (number of revolutions as defined in the specification standard).

The following points should be noted:

- if not described, no underlay is used for the testing;
- the Vetterman drum test starts in the direction of the pile lay in every test;
- the vacuum cleaner and the brush are in use, but the brush is not in direct contact with the use surface.

After the long run test, clean the specimens with the vacuum cleaner (5.1.3), making four forward and backward passes along the length and ensuring that all of the area is covered and that the final pass is in the direction of pile lay.

Allow the specimens to condition flat, singly and pile uppermost for at least 24 h before assessing in accordance with ISO 9405.

Assessments at intermediate numbers of cycles may be carried out provided that the specimens are vacuum cleaned and examined as they are for the final assessment, except that they are assessed immediately without reconditioning.

6 Method B — Hexapod method

6.1 Apparatus

6.1.1 Hexapod tumbler tester, with a plastic drum of the following dimensions:

- internal diameter: (305 ± 1) mm;
- wall thickness: approximately 8 mm;
- internal depth: (210 ± 1) mm.

The drum shall be capable of rotating at a speed of $(0,583 \pm 0,033) \text{ s}^{-1}$ [(35 ± 2) r/min] and shall have facilities for reversing the direction of rotation every 15 min. The drum system shall incorporate a revolution counter and the drum base and lid shall have a locating groove to hold a specimen backing sheet (6.1.2) flat against the inner wall of the drum. Figure 3 illustrates the drum and lid disassembled and Figure 4 shows the drum in cross-section.

6.1.2 Polyethylene specimen backing sheet, of nominal size 950 mm long, 215 mm wide and thickness of 2 mm.

6.1.3 Hexapod, comprising a 50 mm mild steel cube with 25 mm thick plates welded to each face. The outside corners of the plates shall be rounded such that when the studs are fitted and the hexapod placed on a flat surface, no metal touches the flat surface (see Figure 5).

A replaceable polyurethane stud with steel backing shall be screwed centrally into each face.

Diameter of stud:	(40 ± 1) mm
Height of stud:	(15 ± 1) mm
Edge radius of stud:	(15 ± 1) mm
Thickness of steel backing:	$(3 \pm 0,25)$ mm
Shore A hardness, measured in accordance with ISO 868:	$(92,5 \pm 7,5)$
Total mass of hexapod with its six studs:	$(3,8 \pm 0,1)$ kg

The physical properties of height, diameter and hardness shall be tested after every 400 000 cycles. If any of the physical properties of any of the studs are found not to comply with the stud specification, the non-compliant studs shall be replaced.

Studs shall be replaced in any case after two years' use.²⁾

6.1.4 Double-sided adhesive tape, 50 mm wide.

6.1.5 Vaccum cleaner, having a width of suction head at least equal to the width of the specimens.

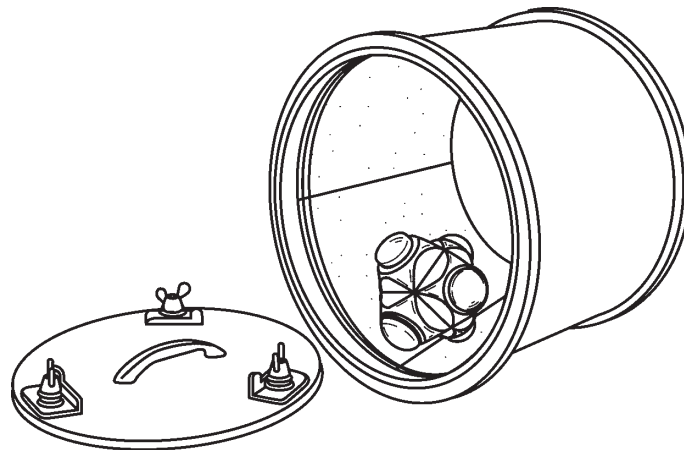
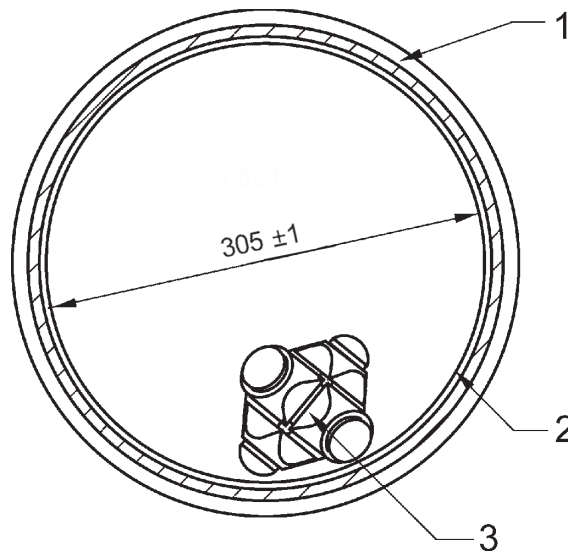

Figure 3 — Hexapod tumbler tester

2) Replacement studs for the hexapod tumbler tester can be obtained from WIRA Instrumentation Ltd, 3 Water Lane, Bradford BD1 2JL, UK.

This information is given for the convenience of users of this International Standard and does not constitute an endorsement by ISO of the product named. Equivalent products may be used if they can be shown to lead to the same results.

Dimensions in millimetres



Key

- 1 plastic drum
- 2 polyethylene specimen backing sheet
- 3 hexapod

Figure 4 — Hexapod tumbler cross-section

Dimensions in millimetres

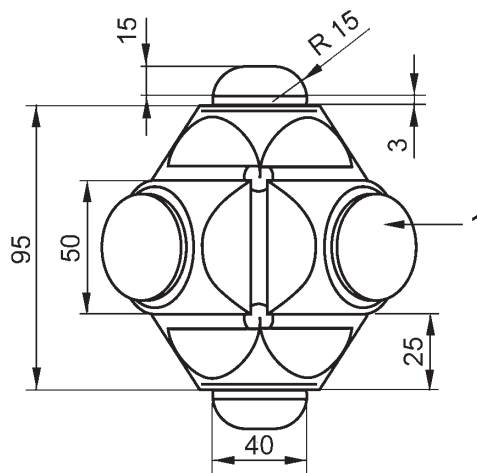

Key

- 1 polyurethane stud

Figure 5 — Hexapod

6.1.6 Rectangular cleaning frame, measuring 1 000 mm × 300 mm, with a central rectangular aperture measuring 940 mm × 200 mm to receive the test specimens, made of material of similar thickness to that of the test specimen and mounted on a rigid backing sheet.

6.2 Atmosphere for conditioning and testing

Use an atmosphere of relative humidity (65 ± 4) %, and of temperature (20 ± 2) °C, in accordance with ISO 139, for both conditioning and testing.

6.3 Selection and preparation of test specimens

6.3.1 Selection

Select the specimens in accordance with ISO 1957 to be as representative as possible of the bulk. Before cutting out the test specimens, mark the sample and each test specimen on the back with an arrow set in the direction of pile lay.

Colour and design may play a large part in the assessment of appearance retention, and this should be borne in mind when selecting specimens.

6.3.2 Number and dimensions

For all materials, specimens shall be tested in both machine and cross-machine direction.

Cut two specimens each measuring 470 mm long by 200 mm wide, one specimen in the direction of manufacture and one specimen in the cross-direction. Cut a similarly sized and positioned specimen for comparison purposes.

Provided that there is no fibre or finish transfer, specimens from up to two different samples of similar thickness may be tested at the same time. In this case, cut the specimens so as to allow for a 5 mm to 10 mm gap between each specimen, to give a total length of 940 mm including the gaps.

Ensure that the pile lay of each specimen is in the same direction and in the direction of rotation of the drum and not laterally across the drum. In each case ensure that cut edges are adequately sealed.

6.3.3 Preparation

Attach double-sided adhesive tape (6.1.4) along each side and end of the backing sheet (6.1.2), leaving 5 mm clear at each edge and pressing down firmly to ensure adhesion. If testing several specimens, attach a piece of tape at each cross-junction. Mount the specimens, use-surface uppermost, allowing a 5 mm gap at each end and between 5 mm and 10 mm between specimens to allow space for the pile when the backing sheet is curved to fit the drum (6.1.1). Check that each specimen is able to lie smoothly when the backing sheet is curved to fit the drum and if necessary adjust its length accordingly.

If required, non-foam backed textile floor coverings may be tested over an underlay by mounting the underlay on the backing sheet as above and then mounting the specimen(s) on the underlay, again using double-sided adhesive tape around the edges. Check that the specimen(s) is able to lie smoothly when the backing sheet is curved to fit the drum and, if necessary, adjust the length accordingly.

Test results apply only to the combination of carpet and specific underlay. They are not valid for combinations with other underlays. For identification of the underlay used it is recommended to give the following details: material, mass per unit area and thickness.

The test specimens shall be cleaned with the upright vacuum cleaner (6.1.5) as described in 6.4, and left to condition flat, singly, pile uppermost for at least 24 h.

6.4 Procedure

Fit the mounted specimens into the drum (6.1.1) ensuring that the backing sheet (6.1.2) lies smoothly around the internal circumference and that it is firmly held by the locating groove.

Check that the studs of the hexapod (6.1.3) are clean, smooth and free from any contamination. If necessary wipe it over with a clean tissue and suitable solvent. Place the hexapod in the drum and replace the lid.

Preset the revolution counter for 2 000 revolutions (approximately 1 h) and switch the machine on to start the test.

Reverse the direction every 15 min (14 min 30 sec rotating and 30 sec stop). Start in the reverse direction.

At the end of this period, remove the mounted specimens and place them in the central aperture of the cleaning frame (6.1.6). Use the vacuum cleaner (6.1.5) every 2 000 revolutions as long as no loose fibres are present

any more. Make a minimum four forward and backward passes along the length of the mounted specimens, ensuring that all the area is covered and that the final pass is in the direction of any pile lay.

Return the specimens to the drum and repeat the above procedure to a total of either the long run test to simulate long-term use in heavy wear situation or the short run test to simulate early changes in appearance or for use in less severe wear sites (number of revolutions as defined in the specification standard).

Give the specimens a final vacuum cleaning as described above.

Allow the specimens to condition flat, singly and pile uppermost for at least 24 h before assessing in accordance with the applicable assessment standard.

Intermediate assessments may be carried out provided that the specimens are vacuum cleaned and examined as they are for the final assessment, except that they are assessed immediately without reconditioning.

7 Test report

The test report shall include the following information:

- a) the identifying characteristics of the test material, in accordance with ISO 2424;
- b) the method used (A or B);
- c) the number of revolutions;
- d) whether an underlay was used, and if so give details;
- e) if applicable, see the reporting clause of the applicable assessment standard;
- f) the type of vacuum cleaner used;
- g) the median value for the appearance change and a statement of the most severe change, in accordance with ISO 9405;
- h) any special observations concerning the test specimens;
- i) details of any deviations from the standard procedure.

ICS 59.080.60

Price based on 9 pages