**Geometrical product specifications
(GPS) — Acceptance and reverification
tests for coordinate measuring
systems (CMS) —**

**Part 9:
CMMs with multiple probing systems**

*Spécification géométrique des produits (GPS) — Essais de
réception et de vérification périodique des systèmes de mesure
tridimensionnels (SMT) —*

Partie 9: MMT avec systèmes de palpage multiples



.....



COPYRIGHT PROTECTED DOCUMENT

© ISO 2013

All rights reserved. Unless otherwise specified, no part of this publication may be reproduced or utilized otherwise in any form or by any means, electronic or mechanical, including photocopying, or posting on the internet or an intranet, without prior written permission. Permission can be requested from either ISO at the address below or ISO's member body in the country of the requester.

ISO copyright office
Case postale 56 • CH-1211 Geneva 20
Tel. + 41 22 749 01 11
Fax + 41 22 749 09 47
E-mail copyright@iso.org
Web www.iso.org

Published in Switzerland

Contents

	Page
Foreword	iv
Introduction	v
1 Scope	1
2 Normative references	1
3 Terms and definitions	2
4 Symbols	5
5 Requirements	5
5.1 Multiple probing system errors	5
5.2 Environmental conditions	5
5.3 Operating conditions	6
6 Testing	6
6.1 General	6
6.2 Principle	6
6.3 Measuring equipment	6
6.4 Procedure	9
6.5 Data analysis	10
7 Compliance with specifications	11
7.1 Acceptance tests	11
7.2 Reverification tests	11
8 Applications	11
8.1 Acceptance tests	11
8.2 Reverification tests	12
8.3 Interim checks	12
9 Indication in product documentation and data sheets	12
Annex A (informative) Example of specification sheet	13
Annex B (informative) Relation to the GPS matrix model	16
Bibliography	18

.....

Foreword

ISO (the International Organization for Standardization) is a worldwide federation of national standards bodies (ISO member bodies). The work of preparing International Standards is normally carried out through ISO technical committees. Each member body interested in a subject for which a technical committee has been established has the right to be represented on that committee. International organizations, governmental and non-governmental, in liaison with ISO, also take part in the work. ISO collaborates closely with the International Electrotechnical Commission (IEC) on all matters of electrotechnical standardization.

The procedures used to develop this document and those intended for its further maintenance are described in the ISO/IEC Directives, Part 1. In particular the different approval criteria needed for the different types of ISO documents should be noted. This document was drafted in accordance with the editorial rules of the ISO/IEC Directives, Part 2 (see www.iso.org/directives).

Attention is drawn to the possibility that some of the elements of this document may be the subject of patent rights. ISO shall not be held responsible for identifying any or all such patent rights. Details of any patent rights identified during the development of the document will be in the Introduction and/or on the ISO list of patent declarations received (see www.iso.org/patents).

Any trade name used in this document is information given for the convenience of users and does not constitute an endorsement.

For an explanation on the meaning of ISO specific terms and expressions related to conformity assessment, as well as information about ISO's adherence to the WTO principles in the Technical Barriers to Trade (TBT), see the following URL: [Foreword - Supplementary information](#)

The committee responsible for this document is ISO/TC 213, *Geometrical product specifications and verification*.

ISO 10360 consists of the following parts, under the general title *Geometrical product specifications (GPS) — Acceptance and reverification tests for coordinate measuring machines (CMM)*:

- *Part 1: Vocabulary*
- *Part 2: CMMs used for measuring linear dimensions*
- *Part 3: CMMs with the axis of a rotary table as the fourth axis*
- *Part 4: CMMs used in scanning measuring mode*
- *Part 5: CMMs using single and multiple stylus contacting probing systems*
- *Part 6: Estimation of errors in computing of Gaussian associated features*
- *Part 7: CMMs equipped with imaging probing systems*

ISO 10360 also consists of the following parts, under the general title *Geometrical product specifications (GPS) — Acceptance and reverification tests for coordinate measuring systems (CMS)*:

- *Part 8: CMMs with optical distance sensors*
- *Part 9: CMMs with multiple probing systems*
- *Part 10: Laser trackers for measuring point-to-point distances*

The following parts are under preparation:

- *Part 12: Articulated-arm CMMs*

Computed tomography is to form the subject of a future part 11.

Introduction

This part of ISO 10360 is a geometrical product specification (GPS) standard and is to be regarded as a general GPS standard (see ISO/TR 14638). It influences chain link 5 of the chains of standards on size, distance, radius, angle, form, orientation, location, run-out and datums.

The ISO/GPS Masterplan given in ISO/TR 14638 gives an overview of the ISO/GPS system of which this document is a part. The fundamental rules of ISO/GPS given in ISO 8015 apply to this document and the default decision rules given in ISO 14253-1 apply to specifications made in accordance with this document, unless otherwise indicated.

For more detailed information on the relation of this part of ISO 10360 to other standards and to the GPS matrix model, see [Annex B](#).

The acceptance and reverification tests described in this part of ISO 10360 are applicable to CMMs that use multiple probing systems in contacting and non-contacting mode. The scope of this part is to test the performance of a multiple probing system CMM when two or more probing systems are used on one measurement task. Its general approach is analogous to the multi-stylus test in ISO 10360-5, but focusing on the performance test of different probing system types, for example an imaging probe combined with a contacting probe on single ram CMMs or on multiple ram CMMs.

© ISO 2012. All rights reserved.

Geometrical product specifications (GPS) — Acceptance and reverification tests for coordinate measuring systems (CMS) —

Part 9: CMMs with multiple probing systems

1 Scope

This part of ISO 10360 specifies procedures for testing the performance of coordinate measuring machines of various designs that use multiple probing systems in contacting and non-contacting mode. It applies to

- acceptance tests for verifying the performance of a CMM and its probes as stated by the manufacturer,
- reverification tests performed by the user for periodical checking of the CMM and its probes,
- interim checks performed by the user for monitoring the CMM and its probes in between reverification tests.

It considers CMMs of single ram designs as well as multiple ram designs with small or with large overlapping measuring volume. It applies to multiple probing systems consisting of different types of probes (such as an imaging probe combined with a contacting probe, or two contacting probes of different individual performance).

The tests described are sensitive to many errors attributable to both the CMM and the probing systems; they supplement the length measurement tests and the individual probing error tests of each probing system. The length measurement tests, as well as the individual probing error tests (for example, ISO 10360-5, ISO 10360-7, or ISO 10360-8), should be performed before executing the procedures in this part of ISO 10360.

2 Normative references

The following documents, in whole or in part, are normatively referenced in this document and are indispensable for its application. For dated references, only the edition cited applies. For undated references, the latest edition of the referenced document (including any amendments) applies.

ISO 10360-1:2000, *Geometrical Product Specifications (GPS) — Acceptance and reverification tests for coordinate measuring machines (CMM) — Part 1: Vocabulary*

ISO 10360-5:2010, *Geometrical product specifications (GPS) — Acceptance and reverification tests for coordinate measuring machines (CMM) — Part 5: CMMs using single and multiple stylus contacting probing systems*

ISO 10360-7:2011, *Geometrical product specifications (GPS) — Acceptance and reverification tests for coordinate measuring machines (CMM) — Part 7: CMMs equipped with imaging probing systems*

ISO 10360-8:2013, *Geometrical product specifications (GPS) — Acceptance and reverification tests for coordinate measuring machines (CMM) — Part 8: CMMs with optical distance sensors*

ISO 14253-1:2013, *Geometrical product specifications (GPS) — Inspection by measurement of workpieces and measuring equipment — Part 1: Decision rules for proving conformity or nonconformity with specifications*

ISO/IEC Guide 99:2007, *International vocabulary of metrology — Basic and general concepts and associated terms (VIM)*

3 Terms and definitions

For the purposes of this document, the terms and definitions given in ISO 10360-1, ISO 14253-1, ISO/IEC Guide 99 and the following apply.

3.1 probing system operating condition
rated operating conditions of a probing system for which the manufacturer's stated performance specifications apply

Note 1 to entry: Each probing system operating condition may be identified by an acronym by which the respective performance values can be referred to. Generally, the manufacturer will specify probing system operating conditions for each probing system, but the manufacturer is free to state several probing system operating conditions for one single probing system. This may include

- stylus length and probe extensions (if applicable),
- mounting (articulated or fixed, use of probe changer),
- illumination,
- qualification procedure,
- permissible surface slope,
- filter settings,
- permissible surface condition (roughness, reflectivity).

For CMMs with computed tomography probing systems (CT), this may also include used magnification and related measuring volume, voltage, power, pre-filtering of the X-ray radiation, and maximum material thickness to be radiographed.

3.2 probing system combination
two or more different types of probing systems and their respective operating conditions

3.3 multi-probe system
probing system with more than one probe

[SOURCE: ISO 10360-1:2000, 3.5]

3.4 multiple probing systems
two or more different types of probes and their respective operating conditions

Note 1 to entry: A probing system combination may occur within the same probing system or in different probing systems (in the case of dual ram CMMs operated in duplex mode).

Note 2 to entry: If a probing combination occurs within a same probing system, the technologies of the different probes are usually different, e.g. a tactile probe and an imaging probe, or two tactile probes with different individual performances. If all the probes are tactile and have identical individual performances, then the probing configuration is also subject to the test given in ISO 10360-5, which is deemed to be more comprehensive than that described in this part of ISO 10360.

3.5 permissible surface condition
rated operating condition of the probing system regarding material and surface characteristics of the artefact

3.6 modes of operation

measurement “in the image” without movement of the probe in alternative to a measurement “at the image” with movement of the probe

Note 1 to entry: Some CMMs, for example those equipped with optical probes or CTs, can be used in different modes of operation.

3.7 multiple probing system form error

$P_{\text{Form.Sph.}n \times 25::\text{MPS}}$

error of indication encompassing the range of radial distances of points measured on a test sphere by a CMM using multiple probing systems from the unconstrained least-squares centre (Gaussian associated feature) of the point set

3.8 multiple probing system size error

$P_{\text{Size.Sph.}n \times 25::\text{MPS}}$

error of indication within which the unconstrained least-squares diameter (Gaussian associated feature) of a test sphere can be determined from points measured by a CMM using multiple probing systems

3.9 multiple probing system location error

$L_{\text{Dia.}n \times 25::\text{MPS}}$

diameter of the minimum circumscribed sphere of points that are the centres of the unconstrained least-squares fits (Gaussian associated features) of sets of points measured on a test sphere by a CMM using multiple probing systems

Note 1 to entry: The minimum circumscribed sphere is the sphere of minimum size that encompasses all centres. Given a set of centres, it is unique.

Note 2 to entry: The minimum circumscribed sphere is different from the minimum zone sphere and should not be confused with.

Note 3 to entry: An upper bound of the diameter of the minimum circumscribed sphere is the spatial diagonal of a minimum circumscribed parallelepiped, possibly aligned to the coordinate axis.

Note 4 to entry: A lower bound of the diameter of the minimum circumscribed sphere is the maximum pair-wise distance between any pair of centres.

Note 5 to entry: Software for evaluating the minimum circumscribed sphere may not be available in a CMM under test. In this case, a tester may decide to evaluate instead the spatial diagonal of a minimum circumscribed parallelepiped (see Note 3) to prove conformance, or the maximum pair-wise distance (see Note 4) to prove non-conformance.

3.10 maximum permissible multiple probing system form error

$P_{\text{Form.Sph.}n \times 25::\text{MPS,MPE}}$

extreme value of the multiple probing system form error permitted by specifications for a CMM

Note 1 to entry: The maximum permissible value of the multiple probing system form error, $P_{\text{Form.Sph.}n \times 25::\text{MPS,MPE}}$, may be expressed in one of three forms:

- a) $P_{\text{Form.Sph.}n \times 25::\text{MPS,MPE}} = \text{minimum of } (A + L_P/K) \text{ and } B, \text{ or}$
- b) $P_{\text{Form.Sph.}n \times 25::\text{MPS,MPE}} = (A + L_P/K), \text{ or}$
- c) $P_{\text{Form.Sph.}n \times 25::\text{MPS,MPE}} = B$

where

ISO 10360-9:2013(E)

- A* is a positive constant, expressed in micrometres and supplied by the manufacturer;
- K* is a dimensionless positive constant supplied by the manufacturer;
- L_P* is the distance in 3D (Euclidian distance) between the centres of the reference sphere and the test sphere, in millimetres;
- B* is the maximum permissible error $P_{\text{Form.Sph.}n \times 25::\text{MPS,MPE}}$, expressed as a positive constant in micrometres, stated by the manufacturer.

3.11 maximum permissible multiple probing system size error

$P_{\text{Size.Sph.}n \times 25::\text{MPS,MPE}}$

extreme value of the multiple probing system size error permitted by specifications for a CMM

Note 1 to entry: The maximum permissible value of the multiple probing system size error, $P_{\text{Size.Sph.}n \times 25::\text{MPS,MPE}}$, may be expressed in one of three forms:

- a) $P_{\text{Size.Sph.}n \times 25::\text{MPS,MPE}} = \text{minimum of } (A + L_P/K) \text{ and } B$, or
- b) $P_{\text{Size.Sph.}n \times 25::\text{MPS,MPE}} = (A + L_P/K)$, or
- c) $P_{\text{Size.Sph.}n \times 25::\text{MPS,MPE}} = B$

where

- A* is a positive constant, expressed in micrometres and supplied by the manufacturer;
- K* is a dimensionless positive constant supplied by the manufacturer;
- L_P* is the distance in 3D (Euclidian distance) between the centres of the reference sphere and the test sphere, in millimetres;
- B* is the maximum permissible error $P_{\text{Size.Sph.}n \times 25::\text{MPS,MPE}}$, expressed as a positive constant in micrometres, stated by the manufacturer.

3.12 maximum permissible multiple probing system location error

$L_{\text{Dia.}n \times 25::\text{MPS,MPE}}$

extreme value of the multiple probing system location error permitted by specifications for a CMM

Note 1 to entry: The maximum permissible value of the multiple probing system location error, $L_{\text{Dia.}n \times 25::\text{MPS,MPE}}$, may be expressed in one of three forms:

- d) $L_{\text{Dia.}n \times 25::\text{MPS,MPE}} = \text{minimum of } (A + L_P/K) \text{ and } B$, or
- e) $L_{\text{Dia.}n \times 25::\text{MPS,MPE}} = (A + L_P/K)$, or
- f) $L_{\text{Dia.}n \times 25::\text{MPS,MPE}} = B$

where

- A is a positive constant, expressed in micrometres and supplied by the manufacturer;
- K is a dimensionless positive constant supplied by the manufacturer;
- L_P is the distance in 3D (Euclidian distance) between the centres of the reference sphere and the test sphere, in millimetres;
- B is the maximum permissible error $L_{\text{Dia.Sph.}n \times 25::\text{MPS,MPE}}$, expressed as a positive constant in micrometres, stated by the manufacturer.

4 Symbols

For the purpose of this part of ISO 10360, the symbols in [Table 1](#) apply.

Table 1 — Symbols

Symbol	Meaning
$P_{\text{Form.Sph.}n \times 25::\text{MPS}}$	multiple probing system form error
$P_{\text{Size.Sph.}n \times 25::\text{MPS}}$	multiple probing system size error
$L_{\text{Dia.}n \times 25::\text{MPS}}$	multiple probing system location error
$P_{\text{Form.Sph.}n \times 25::\text{MPS,MPE}}$	maximum permissible multiple probing system form error
$P_{\text{Size.Sph.}n \times 25::\text{MPS,MPE}}$	maximum permissible multiple probing system size error
$L_{\text{Dia.}n \times 25::\text{MPS,MPE}}$	maximum permissible multiple probing system location error

NOTE 1 See [6.3](#) for the notation for 2D cases.

NOTE 2 See [Clause 9](#) for the indications of these symbols in product documentation, drawings, data sheets, etc.

5 Requirements

5.1 Multiple probing system errors

The errors $P_{\text{Form.Sph.}n \times 25::\text{MPS}}$, $P_{\text{Size.Sph.}n \times 25::\text{MPS}}$ and $L_{\text{Dia.}n \times 25::\text{MPS}}$ shall not exceed the corresponding maximum permissible errors $P_{\text{Form.Sph.}n \times 25::\text{MPS,MPE}}$, $P_{\text{Size.Sph.}n \times 25::\text{MPS,MPE}}$ and $L_{\text{Dia.}n \times 25::\text{MPS,MPE}}$. The MPEs are specified by

- the manufacturer, in the case of acceptance tests,
- the user, in the case of reverification tests.

The errors, and their corresponding maximum permissible errors, are expressed in micrometres.

If technically possible, the manufacturer should specify at least one common set of characteristics $P_{\text{Form.Sph.}n \times 25::\text{MPS,MPE}}$, $P_{\text{Size.Sph.}n \times 25::\text{MPS,MPE}}$ and $L_{\text{Dia.}n \times 25::\text{MPS,MPE}}$, which is valid for the use of all probing system combinations together. Additional MPEs for subsets of probing system combinations may be stated at the manufacturer's discretion (see [Table A.2](#)).

5.2 Environmental conditions

Limits for rated operating conditions such as temperature conditions, air humidity and vibration at the site of installation that influence the measurements shall be specified by

- the manufacturer, in the case of acceptance tests,
- the user, in the case of reverification tests.

In both cases, the user is free to choose the environmental conditions under which the testing will be performed within the rated operating conditions given by the manufacturer.

The user is responsible for providing the environment enclosing the CMM as specified by the manufacturer. If the environment does not meet the rated operating conditions then none of the maximum permissible errors can be required to be verified.

5.3 Operating conditions

For the tests specified in [Clause 6](#), the CMM shall be operated using the procedures given in the manufacturer's operating manual. Specific areas of the manufacturer's manual to be adhered to include

- machine start up/warm up cycles,
- the rated operating conditions shall be met for all probing systems under test as defined in the individual probing system test,
- cleaning procedures for probing system, reference sphere and test sphere for testing, and
- probing system qualification.

All critical components of the probing systems, for instance stylus tips, lenses and mirrors, the reference sphere and the test sphere shall be cleaned before the probing system qualification. Thermal equilibrium of the probing system before and during the probing system qualification shall be ensured. The rated operating conditions shall be clearly stated. This also includes the orientation of the probes.

6 Testing

6.1 General

In the following:

- acceptance tests are executed according to the manufacturer's specifications and procedures;
- reverification tests are executed according to the user's specifications and the manufacturer's procedures.

6.2 Principle

This test applies to specified MPEs that correspond to a probing system combination. Each of these individual probing systems shall be used within the operating conditions. The principle of this test procedure is to measure a test sphere with each individual probing system of a multiple probing system. Each probing system (n = number of tested probing systems) is used to measure the test sphere within a surface slope according to rated operating conditions of each probing system (see [Figure 1](#)). For each group of points, taken with a single probing system, an unconstrained least-squares sphere fit (Gaussian associated feature) is required. The diameter of the minimum circumscribed sphere containing all n centres yields the location error $L_{\text{Dia}.n \times 25::\text{MPS}}$. In addition, an unconstrained least-squares sphere fit (Gaussian associated feature) using all points of all probing systems in the test is examined for the form and size errors of indication $P_{\text{Form.Sph}.n \times 25::\text{MPS}}$ and $P_{\text{Size.Sph}.n \times 25::\text{MPS}}$.

6.3 Measuring equipment

The material standard of size, a test sphere, shall have a nominal diameter of no less than 10 mm and no greater than 51 mm. The use of a test sphere with a different diameter has to be disclosed by the manufacturer. In case of an "in the image" measurement mode with non-contacting probing systems, the diameter of the test sphere shall be between 10 % and 20 % of the space diagonal of the measuring volume of the probe in the used magnification.

The test sphere shall be calibrated for size and form. Since the form and the size deviation influences the test result, it shall be taken into account using ISO 14253-1 when proving conformance or non-conformance with the relevant specification.

It is recommended that the form error of the test sphere does not exceed 20 % of $P_{\text{Form.Sph.}n \times 25::\text{MPS,MPE}}$.

The surface characteristics of the test sphere and any necessary treatment has to be specified by the manufacturer. The reference sphere or any other equipment supplied with the CMM for probing system qualification purposes shall not be used for this test.

If the multiple probing system performance test on a CMM equipped with at least one non contacting probe cannot be executed by measurement of a sphere (for example, in the case of an imaging probe with fixed optical axis), the manufacturer has to specify the material standard of size (for example, ring structure, ring gauge). Only material standards of size with calibrated size and form shall be used. If a sphere is not used for one of the probing system combinations, the manufacturer shall state the artefact to be used and the measuring orientation. The notation shall be in the form:

- $P_{\text{Form.Cir.}n \times 25:\text{XY:MPS}}$ and $P_{\text{Form.Cir.}n \times 25:\text{XY:MPS,MPE}}$ for multiple probing system form error restricted to the XY plane;
- $P_{\text{Size.Cir.}n \times 25:\text{XY:MPS}}$ and $P_{\text{Size.Cir.}n \times 25:\text{XY:MPS,MPE}}$ for multiple probing system size error restricted to the XY plane;
- $L_{\text{Dia.Cir.}n \times 25:\text{XY:MPS}}$ and $L_{\text{Dia.Cir.}n \times 25:\text{XY:MPS,MPE}}$ for multiple probing system location error restricted to the XY plane.

The notations for the YZ plane and for the ZX plane are accordingly.

The length measurement specification (for example according ISO 10360-2 for tactile probing systems or according ISO 10360-7 for imaging probing systems) is not required for all probes.

At least one of the probe configurations included in the specification of the length measurement errors (for example, ISO 10360-2 or ISO 10360-7) shall also be included in the specification of the multiple probing systems errors. If an individual probing system does not have a length measurement specification or cannot be metrologically connected to a probe configuration used to provide the length measurement specification (e.g. as specified in ISO 10360-2) through some combination of probing systems specified in this standard, then the length measurement specification, and corresponding metrological traceability, of the CMM using this probing system cannot be ensured.

NOTE 1 A metrological connection can be direct, i.e. through a specification of the probing system used in length measurement specification to the probing system under consideration, or indirectly, by specification to another probing system which has itself been specified to the probing system used in the length measurement specification.

The integrator of the probes is responsible for the multiple probing systems specification including the rated conditions and for the definition of the artefacts to be used for all probing system combinations. Calibrated artefacts must be available for both parties.

NOTE 2 The orientation of the probes is part of the rated operating conditions.

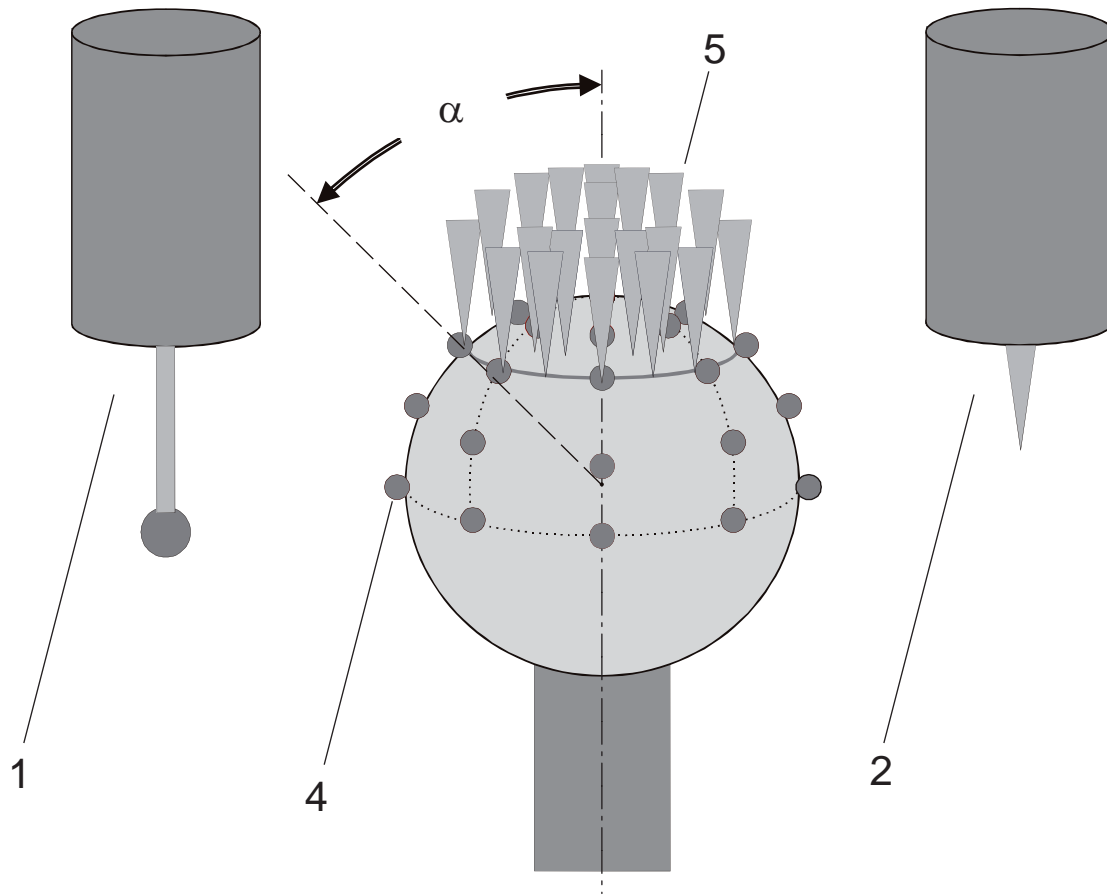

a) Contacting probe and optical distance probe

Figure 1 — (continued on the next page)

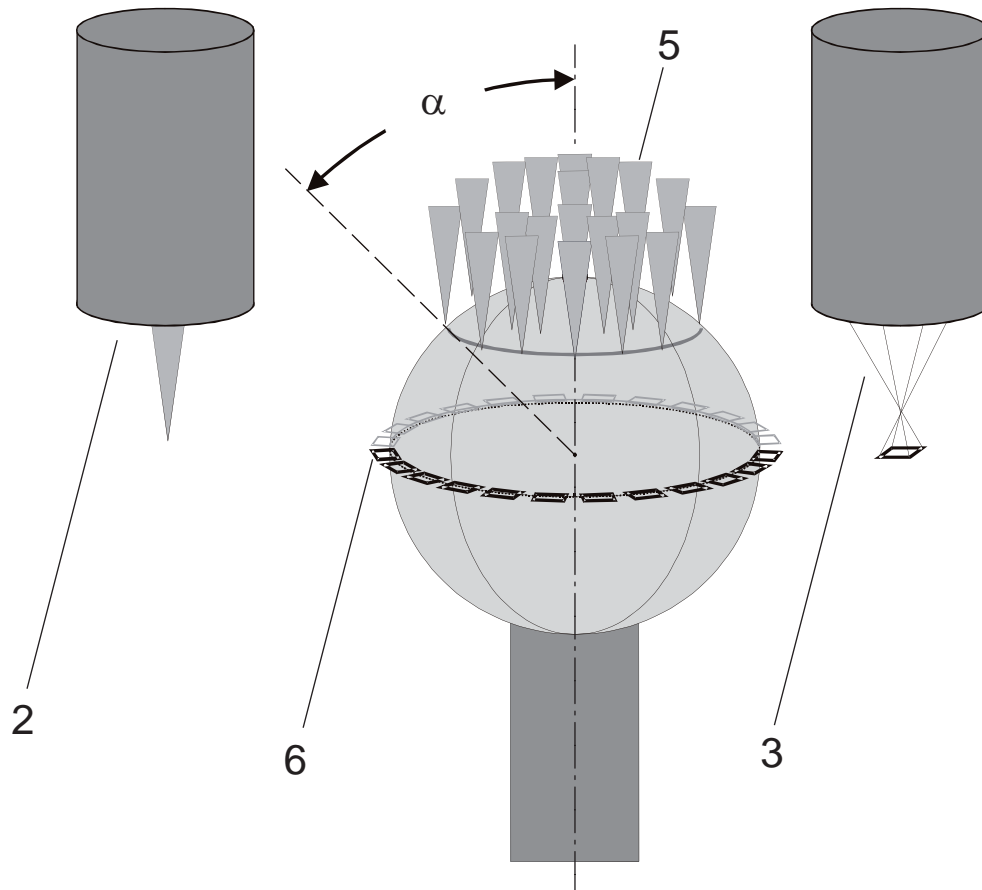

b) Optical distance probe and imaging probe

Key

- 1 contacting probe
- 2 optical distance probe
- 3 imaging probe
- 4 probing points of the contacting probe
- 5 probing points of the optical distance probe specified by the manufacturer to a surface slope from 0° to α
- 6 probing points of the imaging probe restricted to the XY plane measurement on the equator of the test sphere

Figure 1 — Two examples of probing system combinations probing a test sphere

6.4 Procedure

All tested probing systems shall be qualified in accordance with the CMM manufacturer's normal operating procedures.

Three positions (locations in the measuring volume) of the test sphere are required. The sphere positions shall be varied in all axes, with one position close to the reference sphere and the other two positions a significant fraction of up to 50 % of the CMM's travel from the reference sphere. The user is free to choose the location within the limits of specification.

Three positions are necessary to test the correct alignment of the probes.

If a probe is able to measure "at the image" like for example a CT, at least one test sphere shall be placed in a position, where it will be recorded in approximately equal proportions in at least two partial images, which have to be assembled into one overall image or volume.

For each of the n probing systems, measure the test sphere using 25 points for a total of n times at each of the three positions. The points shall be approximately evenly distributed over the angular range, limited by the permissible surface slope of the probing system described in the probing system operating conditions. If no permissible surface slope is specified, a hemisphere of the test sphere shall be covered.

Possible distributions of measuring points are defined in ISO 10360-5 for tactile probing systems, ISO 10360-7 for imaging probing systems and ISO 10360-8 for optical distance sensors. In these parts, procedures are also defined that apply when a probe is capable of measuring multiple points within an area and reducing them to one representative point. These procedures enable the user to reduce the multiple points of the 25 areas to one representative point per area and can be applied for the multiple probing systems test, if they are part of the normal measurement process and if not stated otherwise by the manufacturer.

When the use of a 2D artefact is defined for a probing system combination, 25 points are measured over the whole artefact in regular spacing as discrete points or as non overlapping areas.

When using an automatic probe changing system without a requirement for re-qualification, the user is free to perform a changing operation during the test, unless otherwise specified by the manufacturer.

The test procedure for CMMs with multiple rams is the same as for multiple probing systems used on a single ram CMM if the measuring volume is overlapping to a high extent. If there is a small overlapping measuring volume, the multiple probing systems test shall be done for the probing systems of each ram separately.

For multiple ram CMMs, it is recommended that the length measurement error be tested with at least one probe on each ram. By mutual agreement and in case of large overlapping measuring volume, this may be replaced by a length measurement test with one probe and an increased number of positions for the multiple probing systems test.

6.5 Data analysis

The data of the three locations of the test sphere are analysed separately. Associate an unconstrained least-squares sphere fit (Gaussian associated feature) for each group of 25 points taken with a single probing system, for a total of n sphere fits. The diameter of the minimum circumscribed sphere containing all n centres per location of the test sphere yields the location error $L_{\text{Dia}.n \times 25::\text{MPS}}$.

NOTE When a probing system combination consists of 2D probes and of 3D probes, the evaluation of a sphere might not be possible. If three coordinates are not available, the multiple probing system location error $L_{\text{Dia}.n \times 25::\text{MPS}}$ can be determined for two coordinates only based on a circle evaluation.

Associate one common least-squares sphere fit (Gaussian associated feature) without constraints for all n times 25 points taken with all n probing systems. Record the absolute value of the deviation of the sphere fit diameter from the calibrated value of the test sphere to give the multiple probing system size error, $P_{\text{Size}.Sph.n \times 25::\text{MPS}}$.

Similarly, record the range of radial distances of the n times 25 points with respect to the unconstrained least-squares sphere centre, that is to say $R_{\text{max}} - R_{\text{min}}$, the apparent sphere form. The absolute value of this difference is the multiple probing system form error, $P_{\text{Form}.Sph.n \times 25::\text{MPS}}$.

The measurement points collected with each probe shall be handled in accordance with each single probing error test, according to ISO 10360-5, ISO 10360-7 or ISO 10360-8, as applicable. This includes data rejection and filtering according to the normal operation if specified by the manufacturer. When applicable for a probing system combination, an additional multiple probing system specification is allowed based on the probing dispersion value $P_{\text{Form}.Sph.D95\%:j:\text{ODS}}$ and on the probing size error $P_{\text{Size}.Sph.All:j:\text{ODS}}$ according to ISO 10360-8.

When for the test of a probing system combination the use of an artefact for 2D measurement is defined, the data analysis is based on the evaluation of a 2D feature – in most cases, of a circle – and the evaluation of the probing system location error $L_{\text{Dia}.Cir.n \times 25:XY:\text{MPS}}$ is the diameter of the minimum circumscribed sphere containing the centres of all measured features and the multiple probing system size error $P_{\text{Size}.Cir.n \times 25:\text{MPS}}$ and the multiple probing system form error $P_{\text{Form}.Cir.n \times 25:\text{MPS}}$ are evaluated based on the 2D features.

Repeat the data analysis for the other two locations of the artefact to yield the multiple probing system location error $L_{Dia.n \times 25::MPS}$, the multiple probing system size error $P_{Size.Sph.n \times 25::MPS}$ and the multiple probing system form error $P_{Form.Sph.n \times 25::MPS}$ of these two locations.

7 Compliance with specifications

7.1 Acceptance tests

The CMM multiple probing system performance is verified to comply with the specifications if

- none of the three measured multiple probing system form errors, $P_{Form.Sph.n \times 25::MPS}$, are greater than the relevant maximum permissible multiple probing system form error, $P_{Form.Sph.n \times 25::MPS,MPE}$, as specified by the manufacturer and taking into account the test uncertainty according to ISO 14253-1,
- none of the three measured multiple probing system size errors, $P_{Size.Sph.n \times 25::MPS}$, are greater than the relevant maximum permissible multiple probing system size error, $P_{Size.Sph.n \times 25::MPS,MPE}$, as specified by the manufacturer and taking into account the test uncertainty according to ISO 14253-1,
- none of the three measured multiple probing system location errors, $L_{Dia.n \times 25::MPS}$, are greater than the relevant maximum permissible multiple probing system location error, $L_{Dia.n \times 25::MPS,MPE}$, as specified by the manufacturer and taking into account the test uncertainty according to ISO 14253-1.

If the tests do not demonstrate conformance with this specification, all equipment shall be thoroughly checked for dust, dirt or any operator-induced effect that could be influencing the measurement result, including the critical issue of ensuring that CMM, artefact and all probing system components are in thermal equilibrium. Any faults shall be corrected and the relevant test repeated once only, starting from probing-system qualification and using the same target points.

7.2 Reverification tests

The CMM multiple probing system performance is reverified to comply with the specifications if

- none of the three measured multiple probing system form errors, $P_{Form.Sph.n \times 25::MPS}$, are greater than the relevant maximum permissible multiple probing system form error, $P_{Form.Sph.n \times 25::MPS,MPE}$, as specified by the user and taking into account the test uncertainty according to ISO 14253-1,
- none of the three measured multiple probing system size errors, $P_{Size.Sph.n \times 25::MPS}$, are greater than the relevant maximum permissible multiple probing system size error, $P_{Size.Sph.n \times 25::MPS,MPE}$, as specified by the user and taking into account the test uncertainty according to ISO 14253-1,
- none of the three measured multiple probing system location errors, $L_{Dia.n \times 25::MPS}$, are greater than the relevant maximum permissible multiple probing system location error, $L_{Dia.n \times 25::MPS,MPE}$, as specified by the user and taking into account the test uncertainty according to ISO 14253-1.

If the performance is not verified to comply with the specifications by the tests, all equipment shall be thoroughly checked for dust, dirt or any operator-induced effect that could be influencing the measurement result, including the critical issue of ensuring that CMM, artefact and all probing system components are in thermal equilibrium. Any faults shall be corrected and the relevant test repeated once only, starting from probing-system qualification and using the same target points.

8 Applications

8.1 Acceptance tests

In a contractual situation between a manufacturer and a user such as in a purchasing, maintenance, repair, renovation or upgrade contract, the acceptance tests described in this part of ISO 10360 may be used to verify the probing performance of a CMM with multiple probing systems, in accordance with the specified maximum permissible errors agreed on by the manufacturer and the user.

8.2 Reverification tests

The reverification tests given in this part of ISO 10360 may be used in an organization’s internal quality assurance system for verification of the probing performance of a CMM with multiple probing systems, in accordance with the specified appropriate maximum permissible errors as stated by the user with all possible and detailed limitations applied.

8.3 Interim checks

In an organization’s internal quality assurance system, reduced reverification tests may be used periodically to demonstrate the probability that the CMM conforms to the requirements for maximum permissible errors. The extent of the interim checks for multiple probing systems specified in this part of ISO 10360 may be reduced in respect of the number of actual measuring points being assessed.

It is recommended that the multiple probing system performance be checked regularly, and after any incident which could have significantly affected the probing performance or the geometry of the CMM (for example collisions, exchange of components of the CMM).

9 Indication in product documentation and data sheets

The symbols of [Clause 4](#) may not be suitable for use in product documentation, drawings, data sheets, etc. [Table 2](#) gives the corresponding indications also allowed for.

Table 2 — Symbols and corresponding indication in product documentation, drawings, data sheets, etc.

Symbol used in this document	Corresponding indication
$P_{Form.Sph.n \times 25::MPS}$	$P[Form.Sph.n \times 25::MPS]$
$P_{Size.Sph.n \times 25::MPS}$	$P[Size.Sph.n \times 25::MPS]$
$L_{Dia.n \times 25::MPS}$	$L[Dia.n \times 25::MPS]$
$P_{Form.Sph.n \times 25::MPS,MPE}$	$MPE(P[Form.Sph.n \times 25::MPS])$
$P_{Size.Sph.n \times 25::MPS,MPE}$	$MPE(P[Size.Sph.n \times 25::MPS])$
$L_{Dia.n \times 25::MPS,MPE}$	$MPE(L[Dia.n \times 25::MPS])$

Annex A (informative)

Example of specification sheet

NOTE All the descriptions and values used in [Table A.1](#) are for illustration only.

Table A.1 — Probing system operating conditions

Probing system operating condition	Contacting Probe Type XYZ in discrete point mode
Acronym	CPD
Conditions	<ul style="list-style-type: none"> — discrete point mode — stylus length < 200 mm — mounted vertically on ram
Probing system operating condition	Contacting Probe Type ABC in discrete point mode
Acronym	CPS
Conditions	<ul style="list-style-type: none"> — discrete point mode — stylus length < 100 mm — mounted vertically on ram
Probing system operating condition	Imaging probe 5 times magnification
Acronym	VP5
Conditions	<ul style="list-style-type: none"> — 5 times magnification — back light, dark field or bright field illumination
Probing system operating condition	Imaging probe 10 times magnification
Acronym	VP10
Conditions	<ul style="list-style-type: none"> — 10 times magnification — back light illumination — maximum 100 mm over table — limited to XY plane only
Probing system operating condition	Laser Focus
Acronym	LF
Conditions	<ul style="list-style-type: none"> — Max surface slope $\pm 45^\circ$ — $50 \text{ nm} < Ra < 1 \text{ }\mu\text{m}$ — Metallic surface

For the application of all the probing system combinations, the following MPEs apply (presumed a 3D evaluation is possible despite the 2D probe VP10 is included):

$$P_{\text{Form.Sph.}n \times 25::\text{MPS,MPE}} = \dots \mu\text{m}$$

$$P_{\text{Size.Sph.}n \times 25::\text{MPS,MPE}} = \dots \mu\text{m}$$

$$L_{\text{Dia.}n \times 25::\text{MPS,MPE}} = \dots \mu\text{m}$$

Instead of giving the multiple probing system specification in a table, the manufacturer may also specify the MPEs in the following form:

$$P_{\text{Form.Sph.}n \times 25::\text{MPS,MPE (CPS,VP5)}} = \dots \mu\text{m}$$

A manufacturer may also specify an MPE for a combination of more than two probes. In this case, an MPE in the following form can be stated:

$$P_{\text{Form.Sph.}n \times 25::\text{MPS,MPE (CPS,VP5,LF)}} = \dots \mu\text{m}$$

Table A.2 — Maximum permissible errors

Acronym	CPD	CPS	VP5	VP10 ^b	LF
CPD	<i>Probing error a</i>				
CPS	$P_{Form.Sph.n \times 25::MPS,MPE} =$ $P_{Size.Sph.n \times 25::MPS,MPE} =$ $L_{Dia.n \times 25::MPS,MPE} =$	<i>Probing error a</i>			
VP5	$P_{Form.Sph.n \times 25::MPS,MPE} =$ $P_{Size.Sph.n \times 25::MPS,MPE} =$ $L_{Dia.n \times 25::MPS,MPE} =$	<i>Probing error a</i>	<i>Probing error a</i>		
VP10^b	$P_{Form.Cir.n \times 25:XY:MPS,MPE} =$ $P_{Size.Cir.n \times 25:XY:MPS,MPE} =$ $L_{Dia.Cir.n \times 25:XY:MPS,MPE} =$	$P_{Form.Cir.n \times 25:XY:MPS,MPE} =$ $P_{Size.Cir.n \times 25:XY:MPS,MPE} =$ $L_{Dia.Cir.n \times 25:XY:MPS,MPE} =$	$P_{Form.Cir.n \times 25:XY:MPS,MPE} =$ $P_{Size.Cir.n \times 25:XY:MPS,MPE} =$ $L_{Dia.Cir.n \times 25:XY:MPS,MPE} =$	<i>Probing error a</i>	
LF	$P_{Form.Sph.n \times 25::MPS,MPE} =$ $P_{Size.Sph.n \times 25::MPS,MPE} =$ $L_{Dia.n \times 25::MPS,MPE} =$	$P_{Form.Sph.n \times 25::MPS,MPE} =$ $P_{Size.Sph.n \times 25::MPS,MPE} =$ $L_{Dia.n \times 25::MPS,MPE} =$	$P_{Form.Sph.n \times 25::MPS,MPE} =$ $P_{Size.Sph.n \times 25::MPS,MPE} =$ $L_{Dia.n \times 25::MPS,MPE} =$	$P_{Form.Cir.n \times 25:XY:MPS,MPE} =$ $P_{Size.Cir.n \times 25:XY:MPS,MPE} =$ $L_{Dia.n \times 25:XY:MPS,MPE} =$	<i>Probing error a</i>
^a	Probing error according ISO 10360-5, ISO 10360-7 or ISO 10360-8 depending on the probing system combination.				
^b	2D specification using a 30 mm ring gauge.				

Annex B (informative)

Relation to the GPS matrix model

B.1 General

For full details about the GPS matrix model, see ISO/TR 14638.

B.2 Information about this part of ISO 10360 and its use

The ISO/GPS Masterplan given in ISO/TR 14638 gives an overview of the ISO/GPS system of which this document is a part. The fundamental rules of ISO/GPS given in ISO 8015 apply to this document and the default decision rules given in ISO 14253-1 apply to specifications made in accordance with this document, unless otherwise indicated.

B.3 Position in the GPS matrix model

This part of ISO 10360 is a general GPS standard, which influences chain link 5 of the chains of standards on size, distance, radius, angle, form, orientation, location, run-out and datums in the general GPS matrix, as illustrated in [Table B.1](#).

Table B.1 — Fundamental and general ISO GPS standards matrix

		Global GPS standards					
		General GPS standards					
Fundamental GPS standards	Chain link number	1	2	3	4	5	6
	Size					•	
	Distance					•	
	Radius					•	
	Angle					•	
	Form of line independent of datum					•	
	Form of line dependent on datum					•	
	Orientation					•	
	Location					•	
	Circular run-out					•	
	Total run-out					•	
	Datums					•	
	Roughness profile						
	Waviness profile						
	Primary profile						
	Surface defects						
Edges							
Areal surface texture							

B.4 Related standards

The related standards are those of the chains of standards indicated in [Table B.1](#).

Bibliography

- [1] ISO 8015, *Geometrical product specifications (GPS) — Fundamentals — Concepts, principles and rules*
- [2] ISO 10360-2:2009, *Geometrical product specifications (GPS) — Acceptance and reverification tests for coordinate measuring machines (CMM) — Part 2: CMMs used for measuring linear dimensions*
- [3] ISO 10360-3:2000, *Geometrical Product Specifications (GPS) — Acceptance and reverification tests for coordinate measuring machines (CMM) — Part 3: CMMs with the axis of a rotary table as the fourth axis*
- [4] ISO 10360-4:2000, *Geometrical Product Specifications (GPS) — Acceptance and reverification tests for coordinate measuring machines (CMM) — Part 4: CMMs used in scanning measuring mode*
- [5] ISO/TR 14638, *Geometrical product specification (GPS) — Masterplan*
- [6] ISO 15530 (all parts), *Geometrical product specifications (GPS) — Coordinate measuring machines (CMM): Technique for determining the uncertainty of measurement*
- [7] ISO/TS 23165:2006, *Geometrical product specifications (GPS) — Guidelines for the evaluation of coordinate measuring machine (CMM) test uncertainty*

.....

© ISO 2013. All rights reserved. This document is copyright of the International Organization for Standardization (ISO). It is not to be distributed, reproduced, or used in any form without the prior written permission of ISO.

ICS 17.040.30

Price based on 18 pages