**Geometrical product specifications
(GPS) — Acceptance and reverification
tests for coordinate measuring machines
(CMM) —**

Part 5:
**CMMs using single and multiple stylus
contacting probing systems**

Spécification géométrique des produits (GPS) — Essais de réception et de vérification périodique des machines à mesurer tridimensionnelles (MMT) —

Partie 5: MMT utilisant des systèmes de palpation à stylet simple et à stylets multiples



PDF disclaimer

This PDF file may contain embedded typefaces. In accordance with Adobe's licensing policy, this file may be printed or viewed but shall not be edited unless the typefaces which are embedded are licensed to and installed on the computer performing the editing. In downloading this file, parties accept therein the responsibility of not infringing Adobe's licensing policy. The ISO Central Secretariat accepts no liability in this area.

Adobe is a trademark of Adobe Systems Incorporated.

Details of the software products used to create this PDF file can be found in the General Info relative to the file; the PDF-creation parameters were optimized for printing. Every care has been taken to ensure that the file is suitable for use by ISO member bodies. In the unlikely event that a problem relating to it is found, please inform the Central Secretariat at the address given below.



COPYRIGHT PROTECTED DOCUMENT

© ISO 2010

All rights reserved. Unless otherwise specified, no part of this publication may be reproduced or utilized in any form or by any means, electronic or mechanical, including photocopying and microfilm, without permission in writing from either ISO at the address below or ISO's member body in the country of the requester.

ISO copyright office
Case postale 56 • CH-1211 Geneva 20
Tel. + 41 22 749 01 11
Fax + 41 22 749 09 47
E-mail copyright@iso.org
Web www.iso.org

Published in Switzerland

Contents

Page

Foreword	v
Introduction.....	vi
1 Scope	1
2 Normative references	2
3 Terms and definitions	2
4 Symbols.....	6
5 Requirements for metrological characteristics.....	7
5.1 Single-stylus probing error	7
5.2 Single-stylus probing configuration.....	8
5.3 Multi-stylus probing errors and values	8
5.4 Multi-stylus probing configurations	9
5.5 Styli	9
5.6 Environmental conditions	9
5.7 Operating conditions	9
6 Acceptance tests and reverification tests	10
6.1 General	10
6.2 Single-stylus probing configuration.....	10
6.2.1 Application	10
6.2.2 Principle.....	10
6.2.3 Measuring equipment	10
6.2.4 Procedure	11
6.2.5 Derivation of test results	12
6.3 Fixed multi-probe and multi-stylus probing systems.....	12
6.3.1 Principle.....	12
6.3.2 Measuring equipment	13
6.3.3 Procedure	14
6.3.4 Data analysis.....	15
6.4 Articulating probing systems.....	16
6.4.1 Principle.....	16
6.4.2 Measuring equipment	17
6.4.3 Procedure	17
6.4.4 Data analysis.....	19
7 Compliance with specification.....	19
7.1 Acceptance tests	19
7.2 Reverification tests	20
8 Applications	20
8.1 Acceptance tests	20
8.2 Reverification tests	20
8.3 Interim checks	20
9 Indication in product documentation and data sheets.....	21
Annex A (informative) Symbols and subscripts	23
Annex B (informative) Checking the probing system prior to the ISO 10360-2 test	24
Annex C (informative) Interpretation of multi-stylus test results.....	25
Annex D (normative) Maximum permissible error/limit figures	27

Annex E (informative) Relation to the GPS matrix model	28
Bibliography	30

Foreword

ISO (the International Organization for Standardization) is a worldwide federation of national standards bodies (ISO member bodies). The work of preparing International Standards is normally carried out through ISO technical committees. Each member body interested in a subject for which a technical committee has been established has the right to be represented on that committee. International organizations, governmental and non-governmental, in liaison with ISO, also take part in the work. ISO collaborates closely with the International Electrotechnical Commission (IEC) on all matters of electrotechnical standardization.

International Standards are drafted in accordance with the rules given in the ISO/IEC Directives, Part 2.

The main task of technical committees is to prepare International Standards. Draft International Standards adopted by the technical committees are circulated to the member bodies for voting. Publication as an International Standard requires approval by at least 75 % of the member bodies casting a vote.

Attention is drawn to the possibility that some of the elements of this document may be the subject of patent rights. ISO shall not be held responsible for identifying any or all such patent rights.

ISO 10360-5 was prepared by Technical Committee ISO/TC 213, *Dimensional and geometrical product specifications and verification*.

This second edition cancels and replaces the first edition (ISO 10360-5:2000), which has been technically revised, and ISO/PAS 12868:2009.

ISO 10360 consists of the following parts, under the general title *Geometrical Product Specifications (GPS) — Acceptance and reverification tests for coordinate measuring machines (CMM)*:

- *Part 1: Vocabulary*
- *Part 2: CMMs used for measuring linear dimensions*
- *Part 3: CMMs with the axis of a rotary table as the fourth axis*
- *Part 4: CMMs used in scanning measuring mode*
- *Part 5: CMMs using single and multiple stylus contacting probing systems*
- *Part 6: Estimation of errors in computing Gaussian associated features*
- *Part 7: CMMs equipped with video probing systems*
- *Part 9: CMMs with multiple probing systems*

The following parts are under preparation:

- *Part 8: CMMs with optical distance sensors*
- *Part 10: Laser trackers for measuring point-to-point distances*

Introduction

This part of ISO 10360 is a geometrical product specification (GPS) standard and is to be regarded as a general GPS standard (see ISO/TR 14638). It influences chain link 5 of the chains of standards of size, distance, radius, angle, form, orientation, location, run-out and datums.

For more detailed information on the relation of this part of ISO 10360 to other standards and the GPS matrix model, see Annex E.

The acceptance and reverification tests described in this part of ISO 10360 are applicable to coordinate measuring machines (CMMs) that use contacting probes, with or without multiple styli or multiple articulated-probe positions, when measuring a workpiece.

Experience has shown that the multi-stylus errors calculated using this part of ISO 10360 are significant and, at times, the dominant errors in the CMM. Owing to the virtually infinite variety of modern CMM probing system configurations, the tests specified by this part of ISO 10360 have been limited to providing a testing format only. The tests are intended to provide information on the ability of a CMM to measure a feature or features, using a contacting probe and, when relevant, using multiple styli, multiple probes or multiple articulated-probe positions.

The situations to which they are applicable include

- single-stylus probing systems,
- multiple styli connected to the CMM probe (e.g. a star),
- installations using an articulating probing system (motorized or manual) that can be prequalified,
- installations using a repeatable probe-changing system,
- installations using a repeatable stylus-changing system, and
- multi-probe installations.

It is believed that the procedures given in this part of ISO 10360 will be helpful in identifying CMM system uncertainty components for specific measurement tasks, and that the user will be able to reduce errors by removing contributing elements such as long probe extensions and styli, then retesting the new configuration set.

The tests in this part of ISO 10360 are sensitive to many errors attributable to both the CMM and the probing system, and are to be performed in addition to the length-measuring tests given in ISO 10360-2.

The primary objective is to determine the practical performance of the complete CMM and probing system. Therefore, the tests are designed to reveal measuring errors which are likely to occur when such a combined system is used on real workpieces, e.g. errors generated by the interaction between large probe-tip-offset lengths and uncorrected CMM rotation errors. The errors found here differ from those found in the E_L tests in ISO 10360-2:2009, 6.5, because with multiple styli the net CMM travel may be very different from the measured length. See Annex C for more information.

Geometrical product specifications (GPS) — Acceptance and reverification tests for coordinate measuring machines (CMM) —

Part 5: CMMs using single and multiple stylus contacting probing systems

1 Scope

This part of ISO 10360 specifies acceptance and periodic reverification tests of CMM performance with contacting probing systems and is only applicable to CMMs using

- any type of contacting probing system,
- a discrete point probing mode, and
- spherical or hemispherical stylus tip(s).

It complements ISO 10360-7, which is the module for CMMs with video probing systems, and ISO 10360-2, which is universal, i.e. not probe-type specific.

NOTE It is the CMM probing performance tests which are specified by the maximum permissible errors (MPEs), due to the impracticality of isolating the performance of the probing system from that of the CMM, even on a small artefact such as a test sphere.

This part of ISO 10360 applies to CMMs supplied with any of the following:

- a) single-stylus probing system;
- b) multi-stylus probing systems with fixed multiple styli attached to a single probe (e.g. “star” stylus);
- c) multiple probing systems such as those with a stylus for each of their probes;
- d) systems with articulating probing;
- e) stylus and probe changing systems;
- f) manual (non-driven) CMMs.

This part of ISO 10360 is not applicable to non-contacting probing systems, which require different testing procedures.

The terms “multi-stylus size error”, etc., should strictly be written “combined CMM and multi-stylus probing-system size error”, etc. For convenience, the wording has been truncated.

If it is desired to isolate the probing-system performance as far as is practical, the influence of the CMM can be minimized. See Annex C for more information.

2 Normative references

The following referenced documents are indispensable for the application of this document. For dated references, only the edition cited applies. For undated references, the latest edition of the referenced document (including any amendments) applies.

ISO 10360-1:2000, *Geometrical Product Specifications (GPS) — Acceptance and reverification tests for coordinate measuring machines (CMM) — Part 1: Vocabulary*

ISO 10360-2:2009, *Geometrical Product Specifications (GPS) — Acceptance and reverification tests for coordinate measuring machines (CMM) — Part 2: CMMs used for measuring linear dimensions*

ISO 14253-1, *Geometrical Product Specifications (GPS) — Inspection by measurement of workpieces and measuring equipment — Part 1: Decision rules for proving conformance or non-conformance with specifications*

ISO/IEC Guide 99, *International vocabulary of metrology — Basic and general concepts and associated terms (VIM)*

3 Terms and definitions

For the purposes of this document, the terms and definitions given in ISO 10360-1, ISO 14253-1, ISO/IEC Guide 99 and the following apply.

NOTE This clause contains eight definitions (3.6 to 3.13) which supersede fourteen similar definitions in Clause 9 of ISO 10360-1:2000. Some of these revised definitions are required to avoid ambiguities which would otherwise have been introduced with this edition of ISO 10360-5. Others effectively supersede identical definitions in ISO 10360-1, because the symbols used have been revised and expanded for clarification. The superseded definitions are 9.3, 9.4 and 9.15 to 9.26.

3.1 inferred probing-system qualification

probing-system qualification method where the parameters for each probing system attached to an articulation system are inferred by interpolation, extrapolation, or other relevant model, for significantly different angular position(s) from parameters acquired by **empirical probing-system qualification** (3.3) at a few angular positions

3.2 angular positioning device qualification

establishment of the parameters of the angular positioning device in an articulating probing system necessary for subsequent **inferred probing-system qualification** (3.1)

3.3 empirical probing-system qualification

probing-system qualification method where the parameters for each probing system attached to an articulation system must be acquired by measurement of the reference sphere at each angular position used

3.4 effective stylus tip diameter

diameter used for the tip correction vector, for compensating measured feature size, etc.

NOTE 1 For the position of the tip correction vector, see ISO 10360-1:2000, Figure 4.

NOTE 2 The effective stylus tip diameter may be a parameter established by a probing-system qualification.

3.5 probing-system pre-qualification

probing-system qualification which is separated from subsequent measurement by probe or stylus change(s), and/or articulating probing-system re-orientation(s)

3.6 multi-stylus form (measurement) error

 P_{FTj}

error of indication within which the range of Gaussian radial distances can be determined by a least-squares fit of points measured on a test sphere, the measurements being taken with five different styli on the one test sphere located anywhere in the measuring volume by a CMM using the discrete-point probing mode

See ISO 10360-1:2000, Figure 15.

NOTE 1 The character P in P_{FTj} indicates that the error is associated with the probing-system performance, and the subscript F indicates that it is a form error. The subscript T indicates that the probing system conforms to Clause 1 of this part of ISO 10360 (i.e. tactile), thus enabling any alternative probing system to be clearly identified by the use of a different character at * in P_{F*j} .

NOTE 2 There are four multi-stylus form errors based on different probing systems and methods of operation. These are designated as follows:

$j = E$, an articulating probing system using empirical qualification;

$j = I$, an articulating probing system using inferred qualification;

$j = M$, a fixed multi-stylus probing system;

$j = N$, a fixed multi-probe system.

NOTE 3 All the symbols used in this part of ISO 10360 are listed in Annex A.

3.7 multi-stylus size error

 P_{STj}

error of indication within which the diameter of a test sphere can be determined by a least-squares fit of points, the measurements being taken with five different styli on the one test sphere located anywhere in the measuring volume by a CMM using the discrete-point probing mode

NOTE 1 The subscript S in P_{STj} indicates that it is a size error.

NOTE 2 All the symbols used in this part of ISO 10360 are listed in Annex A.

3.8 multi-stylus location value

 P_{LTj}

maximum of the ranges of the X, Y and Z coordinates within which the location of a test sphere can be determined by a least-squares fit of points, the measurements being taken with five different styli on the one test sphere located anywhere in the measuring volume by a CMM using the discrete-point probing mode

NOTE 1 The subscript L in P_{LTj} indicates that it is a location value.

NOTE 2 All the symbols used in this part of ISO 10360 are listed in Annex A.

NOTE 3 All values are absolute.

3.9 single-stylus form error

 P_{FTU}

error of indication within which the range of radii can be determined by a least-squares fit of points measured on a test sphere, the measurements being performed by a CMM with a single stylus, using the discrete-point probing mode, with points taken on the test sphere located anywhere in the measuring volume

See ISO 10360-1:2000, Figure 15.

NOTE 1 The character P in P_{FTU} indicates that the error is related primarily to the probing-system performance. The subscript U indicates use of a single (unique) stylus.

NOTE 2 See 3.6 for information on F and T.

NOTE 3 All such characters used in this part of ISO 10360 are listed in Annex A.

NOTE 4 P_{FTU} is identical to P in ISO 10360-2:2001.

**3.10
single-stylus size error**

P_{STU}

error of indication of the difference between the diameter of a least-squares fit of points measured on a test sphere and its calibrated diameter, the measurements being performed by a CMM with a single stylus, using the discrete-point probing mode, with points taken on the test sphere located anywhere in the measuring volume

NOTE 1 The character P in P_{STU} indicates that the error is related primarily to the probing-system performance. The subscript U indicates use of a single (unique) stylus. The subscript S in P_{STj} indicates that it is a size error.

NOTE 2 All such characters used in this part of ISO 10360 are listed in Annex A.

**3.11
maximum permissible multi-stylus form error**

$P_{FTj, MPE}$

extreme value of the **multi-stylus form error** (3.6), P_{FTj} , permitted by specifications, regulations, etc. for a CMM

NOTE 1 The maximum permissible value of the multi-stylus form error, $P_{FTj, MPE}$, can be expressed in one of three forms:

a) $P_{FTj, MPE} = \text{minimum of } (A + L_P/K) \text{ and } B; \text{ or}$

b) $P_{FTj, MPE} = (A + L_P/K); \text{ or}$

c) $P_{FTj, MPE} = B$

where

A is a positive constant, expressed in micrometres and supplied by the manufacturer;

K is a dimensionless positive constant supplied by the manufacturer;

L_P is the distance in 3D between the centres of the reference sphere and the test sphere, in millimetres;

B is the maximum permissible error $P_{FTj, MPE}$, in micrometres, as stated by the manufacturer.

These forms are shown in Figures D.1, D.2 and D.3.

NOTE 2 A maximum permissible error (MPE) as opposed to a maximum permissible limit (MPL) specification is used when the test measurements determine errors; hence, testing an MPE specification requires the use of calibrated artefacts.

NOTE 3 $P_{FTj, MPE}$ can be specified by probe-tip-offset length or by the stylus system description.

**3.12
maximum permissible multi-stylus size error**

$P_{STj, MPE}$

extreme value of the **multi-stylus size error** (3.7), P_{STj} , permitted by specifications, regulations, etc. for a CMM

NOTE 1 The maximum permissible value of the multi-stylus size error, $P_{STj, MPE}$, can be expressed in one of three forms:

a) $P_{STj, MPE} = \text{minimum of } (A + L_P/K) \text{ and } B$; or

b) $P_{STj, MPE} = (A + L_P/K)$; or

c) $P_{STj, MPE} = B$

where

A is a positive constant, expressed in micrometres and supplied by the manufacturer;

K is a dimensionless positive constant supplied by the manufacturer;

L_P is the distance in 3D between the centres of the reference sphere and the test sphere, in millimetres;

B is the maximum permissible error $P_{STj, MPE}$, in micrometres, as stated by the manufacturer.

These forms are shown in Figures D.1, D.2 and D.3.

NOTE 2 A maximum permissible error (MPE) as opposed to a maximum permissible limit (MPL) specification is used when the test measurements determine errors; hence, testing an MPE specification requires the use of calibrated artefacts.

NOTE 3 $P_{STj, MPE}$ can be specified by probe-tip-offset length or by the stylus system description.

3.13

maximum permissible limit of the multi-stylus location value

$P_{LTj, MPL}$

extreme value of the **multi-stylus location value** (3.8), P_{LTj} , permitted by specifications, regulations, etc. for a CMM

NOTE 1 The maximum permissible limit of the multi-stylus location value, $P_{LTj, MPL}$, can be expressed in one of three forms:

a) $P_{LTj, MPL} = \text{minimum of } (A + L_P/K) \text{ and } B$; or

b) $P_{LTj, MPL} = (A + L_P/K)$; or

c) $P_{LTj, MPL} = B$

where

A is a positive constant, expressed in micrometres and supplied by the manufacturer;

K is a dimensionless positive constant supplied by the manufacturer;

L_P is the distance in 3D between the centres of the reference sphere and the test sphere, in millimetres;

B is the maximum permissible limit $P_{LTj, MPL}$, in micrometres, as stated by the manufacturer.

These forms are shown in Figures D.1, D.2 and D.3.

NOTE 2 A maximum permissible limit (MPL) as opposed to a maximum permissible error (MPE) specification is used when the test measurements are not errors; hence, testing an MPL specification does not require the use of artefacts with a relevant calibration.

NOTE 3 $P_{LTj, MPL}$ can be specified by the probe-tip-offset length or by the stylus system description.

3.14 maximum permissible single-stylus form error

$P_{FTU, MPE}$

extreme value of the **single-stylus form error** (3.9), P_{FTU} , permitted by specifications, regulations, etc. for a CMM

See ISO 10360-1:2000, Figure 15.

NOTE 1 $P_{FTU, MPE}$ can be specified by probe-tip-offset length or by the stylus system description.

NOTE 2 $P_{FTU, MPE}$ is identical to MPE_p in ISO 10360-2:2001.

4 Symbols

For the purpose of this document, the symbols of Table 1 apply.

Table 1 — Symbols

Symbol	Meaning
A	Positive constant, expressed in micrometres and supplied by the manufacturer, used to express a maximum permissible limit or error
K	Dimensionless positive constant supplied by the manufacturer, used to express a maximum permissible limit or error
L_P	Distance in 3D between the centres of the reference sphere and the test sphere, in millimetres
B	Maximum permissible error (e.g. $P_{FTj, MPE}$) or limit (e.g. $P_{LTj, MPL}$), in micrometres, as stated by the manufacturer
R	Gaussian radial distance
l	Fixed multi-stylus probing-system stylus length
l_U	Single-stylus length
l_O	Fixed multi-probe-tip-offset length
l_A	Articulating probing-system probe-tip-offset length
X, Y, Z	Centre coordinates
E_0	Length measurement error with minimal probe-tip-offset length
$E_{0, MPE}$	Maximum permissible error of length measurement with minimal probe-tip-offset length
E_L	Length measurement error with probe-tip-offset length L
$E_{L, MPE}$	Maximum permissible error of length measurement
$j = E$	Articulating probing system using empirical qualification
$j = I$	Articulating probing system using inferred qualification
$j = M$	Fixed multi-stylus probing system
$j = N$	Fixed multi-probe system
P_{FTE}	Multi-stylus form error, P_{FTj}
P_{FTI}	
P_{FTM}	
P_{FTN}	

Table 1 (continued)

Symbol	Meaning
P_{STE}	Multi-stylus size error, P_{STj}
P_{STI}	
P_{STM}	
P_{STN}	
P_{LTE}	Multi-stylus location value, P_{LTj}
P_{LTI}	
P_{LTM}	
P_{LTN}	
P_{FTU}	Single-stylus form error
P_{STU}	Single-stylus size error
$P_{FTE, MPE}$	Maximum permissible multi-stylus form error, $P_{FTj, MPE}$
$P_{FTI, MPE}$	
$P_{FTM, MPE}$	
$P_{FTN, MPE}$	
$P_{STE, MPE}$	Maximum permissible multi-stylus size error, $P_{STj, MPE}$
$P_{STI, MPE}$	
$P_{STM, MPE}$	
$P_{STN, MPE}$	
$P_{LTE, MPL}$	Maximum permissible limit of the multi-stylus location value, $P_{LTj, MPL}$
$P_{LTI, MPL}$	
$P_{LTM, MPL}$	
$P_{LTN, MPL}$	
$P_{FTU, MPE}$	Maximum permissible single-stylus form error

5 Requirements for metrological characteristics

5.1 Single-stylus probing error

The single-stylus form error, P_{FTU} , shall not exceed the maximum permissible single-stylus form error, $P_{FTU, MPE}$, as stated by

- the manufacturer, in the case of acceptance tests, or
- the user, in the case of reverification tests.

The single-stylus form error, P_{FTU} , and the maximum permissible single-stylus form error, $P_{FTU, MPE}$, are expressed in micrometres.

NOTE 1 The single-stylus probing error also applies to CMMs used with fixed multiple probes, fixed multiple styli and articulating probing systems (see 6.2.1).

NOTE 2 The influences that contribute to the single-stylus form error, P_{FTU} , are also normally manifested in the values found for E_0 and E_L in ISO 10360-2.

5.2 Single-stylus probing configuration

The limits of the probing-system configuration (stylus, stylus extensions, stylus orientation, weight of stylus system, etc.) to which the stated value of $P_{FTU, MPE}$ applies shall be stated by

- the manufacturer, in the case of acceptance tests, or
- the user, in the case of reverification tests.

In both cases, the user is free to choose the way in which the components of the probing system are configured within the specified limits, and the requirements of 6.2, as relevant.

Use of a stylus relevant to a typical workpiece measuring task is recommended.

NOTE 1 An articulating probing system used at a single angular position, with a single stylus, is deemed to be a single-stylus probing system.

NOTE 2 The limits of the probing-system configuration in this subclause may differ from those in 5.4.

5.3 Multi-stylus probing errors and values

On fixed multi-stylus probing systems, the multi-stylus form and size errors, P_{FTM} , P_{STM} , and the value P_{LTM} shall not exceed the corresponding maximum permissible errors, $P_{FTM, MPE}$, $P_{STM, MPE}$, and maximum permissible limit $P_{LTM, MPL}$.

On fixed multi-probe systems, the multi-stylus form and size errors, P_{FTN} , P_{STN} , and the value P_{LTN} shall not exceed the corresponding maximum permissible errors, $P_{FTN, MPE}$, $P_{STN, MPE}$, and maximum permissible limit $P_{LTN, MPL}$.

On articulating probing systems using inferred probing-system qualification, the multi-stylus form and size errors, P_{FTI} , P_{STI} , and the value P_{LTI} , shall not exceed the corresponding maximum permissible errors, $P_{FTI, MPE}$, $P_{STI, MPE}$, and maximum permissible limit $P_{LTI, MPL}$.

On articulating probing systems using empirical probing-system qualification, the multi-stylus form and size errors, P_{FTE} , P_{STE} , and the value P_{LTE} , shall not exceed the corresponding maximum permissible errors, $P_{FTE, MPE}$, $P_{STE, MPE}$, and maximum permissible limit $P_{LTE, MPL}$.

The maximum permissible errors, $P_{FTj, MPE}$ and $P_{STj, MPE}$, and maximum permissible limit, $P_{LTj, MPL}$, are stated by

- the manufacturer, in the case of acceptance tests, or
- the user, in the case of reverification tests.

The errors and values, and their corresponding maximum permissible errors and limits, are expressed in micrometres.

NOTE Multi-stylus probing performance is broadly categorized into form-related (P_{FTj}) and size-related (P_{STj}) errors, and location-related (P_{LTj}) values. Different combinations of these will be important for the uncertainty of the different measurement tasks. For example, the form and size results may contain information on the ability of the CMM system to use multiple stylus tip diameters in the measurement of a single geometrical feature. See also Annex C.

For articulating systems, data for only one method, either inferred or empirical, are required.

5.4 Multi-stylus probing configurations

The limits of the probing-system configuration (stylus, stylus extensions, probe extensions, weight of stylus system, etc.) to which the stated values of MPE and MPL apply shall be stated by

- the manufacturer, in the case of acceptance tests, or
- the user, in the case of reverification tests.

In both cases, the user is free to choose the way in which the components of the probing system are configured within the specified limits and the requirements of 6.3 or 6.4, as relevant.

A manufacturer may exclude the use of stylus tips of different nominal diameters in the measurement of a single geometric feature, by declaring this restriction in the manufacturer's list of approved styli (see 5.5).

NOTE 1 The limits of the probing-system configuration in this subclause may differ from those in 5.2.

NOTE 2 An articulating probing system used at multiple angular positions, even when used with a single stylus, is deemed to be a multi-stylus probing system.

5.5 Styli

The styli used in the tests specified in Clause 6 shall be those approved by the CMM manufacturer for use with the CMM, i.e. made of the same material, of the same stylus-shaft diameter and nominal length, and having the same stylus-tip quality. However, it is recognized that the exact stylus lengths used for test procedures might not be available, and therefore, a stylus-length variation of 6 mm or 10 % of the nominal length, whichever is the greater, may be used.

5.6 Environmental conditions

Limits for permissible environmental conditions such as temperature conditions, air humidity and vibration at the site of installation that influence the measurements shall be specified by

- the manufacturer, in the case of acceptance tests, or
- the user, in the case of reverification tests.

In both cases, the user is free to choose the environmental conditions under which the testing in this part of ISO 10360-5 will be performed within the manufacturer's specified limits given in the CMM data sheet.

The user is responsible for providing the environment enclosing the CMM as specified by the manufacturer in the data sheet. If the environment does not meet the specifications, then none of the maximum permissible errors or limits in this part of ISO 10360 can be required to be verified.

5.7 Operating conditions

For the tests specified in Clause 6, the CMM shall be operated using the procedures given in the manufacturer's operating manual. Specific areas of the manufacturer's manual to be adhered to include

- a) machine start up/warm up cycles,
- b) stylus system configuration and assembly,
- c) cleaning procedures for the stylus tip, test sphere and reference sphere,
- d) probing-system qualification,
- e) when specified by the manufacturer, the location of the reference sphere as stated in the operating manual.

All stylus tips, the reference sphere and the test sphere shall be cleaned before the probing-system qualification to eliminate residual film which might affect the measuring or test results.

IMPORTANT — Ensuring that approximate thermal equilibrium of the probing system is achieved during the probing-system qualification and testing procedure is critical.

6 Acceptance tests and reverification tests

6.1 General

In the following subclauses

- acceptance tests are executed according to the manufacturer's specifications and procedures, and
- reverification tests are executed according to the user's specifications and the manufacturer's procedures.

6.2 Single-stylus probing configuration

6.2.1 Application

Subclause 6.2 applies to the single-stylus probing configuration and CMMs used with fixed multiple probes, fixed multiple styli and articulating probing systems. One of the multiple probes, or one of the multiple styli, or one of the articulating orientations, may be used for this test. See 6.2.4.1 for their orientation.

6.2.2 Principle

The principle of this test procedure is to measure a test sphere using 25 points probed with a single stylus and to attribute the observed form error to the probing system. A least-squares (i.e. Gaussian) sphere fit of the 25 points is examined for the form errors of indication. This analysis yields the single-stylus form error P_{FTU} .

The results of these tests may be highly dependent on the stylus length. Therefore, a series of stylus lengths is considered (see Figure 1); only those lengths the CMM manufacturer specifies as applicable to the probing system (see 5.2) shall be eligible for test.

Single-stylus length l_u	MPE(P_{FTU}) μm
$l_u = 20 \text{ mm}$	
$l_u = 30 \text{ mm}$	
$l_u = 50 \text{ mm}$	
$l_u = 100 \text{ mm}$	

Figure 1 — Sample single-stylus configuration specification sheet

6.2.3 Measuring equipment

The material standard of size, i.e. the test sphere, shall have a diameter not less than 10 mm and not greater than 50 mm. The test sphere shall be calibrated for form. Performing the test described in Annex B (as well as in multi-probe and multi-stylus tests – see 6.3.3) requires that the size of the test sphere also be calibrated.

It is recommended that the form error of the test sphere does not exceed 20 % of $P_{FTM, MPE}$, or $P_{FTN, MPE}$, as relevant.

The reference sphere supplied with the CMM for probing-system qualification purposes shall not be used for this test.

6.2.4 Procedure

6.2.4.1 The stylus length shall be chosen by the user from the following values: 20 mm, 30 mm, 50 mm and 100 mm (see Figure 1). Only one of the lengths specified by the CMM manufacturer as applicable to the stylus system shall be chosen by the user and tested. The stylus components shall be those approved for use with the CMM probing system (see 5.2), unless otherwise specified. See 5.5 for permitted tolerances on the stylus length.

The stylus orientation shall be parallel to the ram axis, unless otherwise specified.

Any change of orientation of the stylus may significantly affect the test result.

On dual ram CMMs, two separate tests should be run, one with each ram, both in simplex operating mode (see ISO 10360-2:2009).

6.2.4.2 Set up and qualify the probing system in accordance with the manufacturer's normal procedures (see 5.2, 5.5 and 5.7).

6.2.4.3 One location of the test sphere shall be chosen by the user anywhere in the measuring volume. To avoid interference between the probing system and the reference sphere, the reference sphere may be removed from the table during the test.

The test sphere should be mounted rigidly to minimize errors due to bending.

6.2.4.4 Measure and record 25 points. The points shall be approximately evenly distributed over at least a hemisphere of the test sphere. Their position shall be at the discretion of the user and, if not specified, the following probing pattern is recommended (see Figure 2):

- one point on the pole (defined by the direction of the stylus shaft) of the test sphere;
- four points (equally spaced) 22,5° below the pole;
- eight points (equally spaced) 45° below the pole and rotated 22,5° relative to the previous group;
- four points (equally spaced) 67,5° below the pole and rotated 22,5° relative to the previous group;
- eight points (equally spaced) 90° below the pole (i.e. on the equator) and rotated 22,5° relative to the previous group.

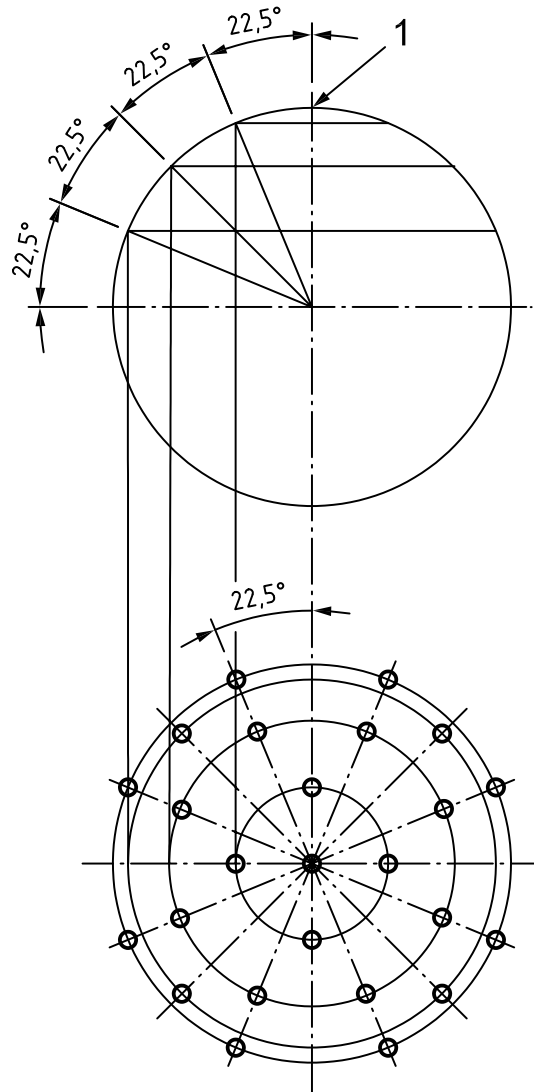

Key

1 pole

Figure 2 — Target contact points

6.2.5 Derivation of test results

6.2.5.1 Using all 25 measurements, compute the Gaussian (i.e. least-squares) associated sphere.

6.2.5.2 For each of the 25 measurements, calculate the Gaussian radial distance, R . Record the range of Gaussian radial distances of the 25 points with respect to the least-squares sphere centre, i.e. $R_{\max} - R_{\min}$, the apparent sphere form. The absolute value of this difference is the single-stylus form error, P_{FTU} .

NOTE See also Annex B when running this test prior to the tests in ISO 10360-2.

6.3 Fixed multi-probe and multi-stylus probing systems

6.3.1 Principle

The principle of this test procedure is to measure the form, size and location of a test sphere using five different fixed styli.

Each stylus probes 25 points on the test sphere, for a total of 125 points for all five styli.

If a stylus or probe changing system is supplied with the CMM, five changes shall be performed, one before each stylus is used. For each group of 25 points taken with a single stylus, associate a least-squares sphere fit, for a total of five sphere fits.

The ranges of the centre coordinates (X, Y and Z) of all five spheres are calculated. The largest of these three ranges yields the multi-stylus location value (P_{LTM} or P_{LTN}). In addition, a least-squares sphere fit using all 125 points is examined for the form and size errors of indication. This analysis yields the multi-stylus size error (P_{STM} or P_{STN}) and multi-stylus form error (P_{FTM} or P_{FTN}).

When a multi-stylus system is used, the results of these tests may be highly dependent on the stylus system. Therefore, a series of stylus lengths is considered (see Figures 3 and 5); only those lengths that the CMM manufacturer specifies as applicable to the stylus system shall be eligible for test.

When a multi-probe system is used, the results of these tests are highly dependent on the offset lengths to the stylus tips. A series of tip offset lengths is considered (see Figure 4), all measured from a single point on the ram axis defined by the CMM manufacturer. Only those offset lengths that the CMM manufacturer specifies as applicable to the probing system shall be eligible for test.

Fixed multi-stylus-system stylus length l	MPE(P_{FTM}) μm	MPE(P_{STM}) μm	MPE(P_{LTM}) μm
$l = 10 \text{ mm}$			
$l = 20 \text{ mm}$			
$l = 30 \text{ mm}$			
$l = 50 \text{ mm}$			
$l = 100 \text{ mm}$			
$l = 200 \text{ mm}$			
$l = 400 \text{ mm}$			

Figure 3 — Sample fixed multi-stylus probing-system specification sheet

Fixed multi-probe-tip-offset length l_o	MPE(P_{FTN}) μm	MPE(P_{STN}) μm	MPE(P_{LTN}) μm
$l_o = 50 \text{ mm}$			
$l_o = 100 \text{ mm}$			
$l_o = 200 \text{ mm}$			
$l_o = 400 \text{ mm}$			

Figure 4 — Sample fixed multi-probe system specification sheet

Only those stylus or probe-tip-offset lengths applicable to the CMM under consideration should be assigned MPE and MPL values in Figures 3 and 4; non-applicable entries may remain blank.

6.3.2 Measuring equipment

The material standard of size, i.e. the test sphere, shall have a diameter not less than 10 mm and not greater than 50 mm. The test sphere shall be calibrated for size and form.

It is recommended that the form error of the test sphere does not exceed 20 % of $P_{FTM, MPE}$, or $P_{FTN, MPE}$, as relevant.

The reference sphere supplied with the CMM for probing-system-qualification purposes shall not be used for this test.

6.3.3 Procedure

6.3.3.1 When a multi-stylus system is used, construct a “star” stylus system composed of one stylus parallel to the axis of the probe and four styli in a plane perpendicular to the axis, each oriented 90° with respect to those adjacent to it. The distance from the probe to the styli connection point shall be the minimum distance possible (consistent with the manufacturer’s recommendations) using the stylus components normally supplied with the CMM (see Figure 5). The applicable values of stylus length, l , shall be equal and specified by the CMM manufacturer, and shall be chosen from the following values: 10 mm, 20 mm, 30 mm, 50 mm, 100 mm, 200 mm and 400 mm (see Figure 3). Only one of the lengths specified by the CMM manufacturer as applicable to the stylus system shall be chosen by the user and tested. The stylus components shall be those approved for use with the CMM probing system, unless otherwise specified. See 5.5 for permitted tolerances on stylus length.

On dual ram CMMs, three of the stylus tips shall be mounted on one ram, and two of the stylus tips on the other ram, all in duplex operating mode (see ISO 10360-2:2009).

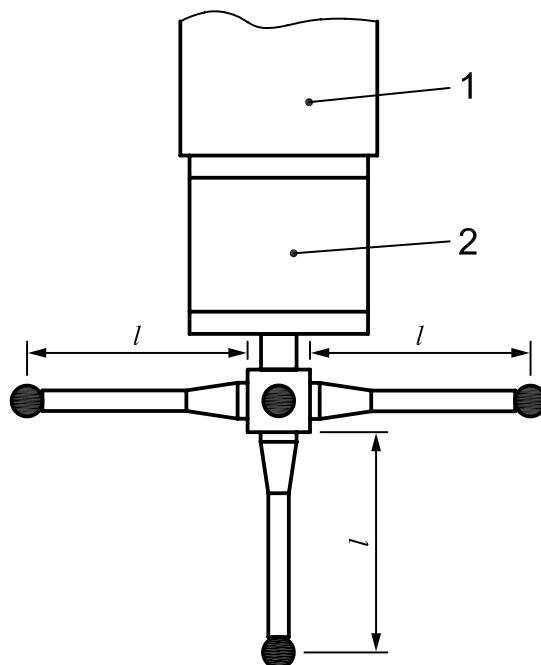

Key

- 1 ram
- 2 probe
- l fixed multi-stylus probing-system length

NOTE For clarity, only four of the five styli and only three shafts are visible.

Figure 5 — Fixed multi-stylus probing system of stylus length l

6.3.3.2 When a multi-probe system is used, attach a short (unless otherwise specified, 20 mm), straight stylus to each of five probes. Assemble them with suitable probe extension components to form a “star” probe system composed of one probe parallel to the axis of the ram and four probes in a plane perpendicular to the axis, each oriented 90° with respect to those adjacent to it. The distances from each of the five stylus tips to a single reference point on the ram axis, the probe-tip-offset lengths, shall all be approximately equal. The applicable values of probe-tip-offset length, l_0 , shall be specified by the CMM manufacturer, and shall be chosen from the following values: 50 mm, 100 mm, 200 mm and 400 mm (see Figure 4). Only one of the

offset lengths specified by the CMM manufacturer as applicable to the probing system shall be chosen by the user and tested. The probing and stylus components shall be those approved for use with the CMM probing system, unless otherwise specified. However, it is recognized that the exact offset lengths required for the test procedure may not be available, and therefore, a change to the nominal value of the offset length of 6 mm or 10 % of the nominal length, whichever is the greater, may be used.

On dual ram CMMs, three of the probes shall be mounted on one ram, and two of the probes on the other ram, all in duplex operating mode (see ISO 10360-2:2009).

6.3.3.3 The five stylus tips shall not be restricted to a single nominal diameter unless such a restriction is explicit in the CMM manufacturer's specification (see 5.4).

6.3.3.4 Qualify the probing system in accordance with the CMM manufacturer's normal operating procedures.

6.3.3.5 One location of the test sphere shall be chosen by the user anywhere in the measuring volume. To avoid interference between the probing system and the reference sphere, the reference sphere may be removed from the table during the test.

The test sphere should be mounted rigidly to minimize errors due to bending.

NOTE The location of the test sphere can significantly affect the results. See Annex C for further information.

6.3.3.6 Measure the test sphere using 25 points with each stylus, for a total of 125 points. The points shall be approximately evenly distributed over at least a hemisphere of the test sphere. Their position shall be at the discretion of the user. The recommended point-sampling strategy is the same as for the single-stylus test (6.2).

When the support stalk for the test sphere is located on the vertical centre line and a horizontal stylus is used, then access should be optimized by orienting the probing pattern so that each of the eight points on the equator is at $22,5^\circ$ to a CMM axis, and the four points in the adjacent plane are at 45° to the Z axis. This is illustrated in Figure 2, if the lower view is considered to be an elevation.

However, if the test sphere is small relative to its support stalk diameter and/or the stylus tip diameter, so that the eight points on the equator cannot be equispaced at 45° over an arc of 315° , then it is recommended that the eight points are equispaced over the available arc.

If a stylus or probe changing system is supplied with the CMM, all five styli shall be qualified, and the styli or probes returned to the rack, before running this test. Five changes shall be performed during the test, each stylus or probe being changed once. However, if fewer than five styli or probe stations are available in the changing system, the maximum number shall be used, with some styli or probes changed more than once to achieve a total of five changes. In the case of a "star" stylus or "star" probe system, the star system shall be returned to the rack and picked up again.

NOTE If the probing-system assembly is identical to that chosen for the single-stylus probing test (see 6.2), there is no need to make the same measurements twice with the one stylus.

6.3.4 Data analysis

6.3.4.1 Associate a least-squares sphere fit for each group of 25 points taken with a single stylus, for a total of five sphere fits. Calculate the range of the centre coordinates (X, Y and Z) of all five spheres. The largest of these three ranges yields the probing-system location value, P_{LTM} or P_{LTN} , as relevant.

6.3.4.2 Associate a least-squares sphere fit for all 125 points taken with all five styli. Record the absolute value of the deviation of the sphere fit diameter from the calibrated value of the material standard of size to give the multi-stylus size error, P_{STM} or P_{STN} , as relevant. Similarly, record the range of radii of the 125 points with respect to the least-squares sphere centre, i.e. $R_{max} - R_{min}$, the apparent sphere form. The absolute value of this difference is the multi-stylus form error, P_{FTM} or P_{FTN} , as relevant.

NOTE According to 6.3.3.3, the five tips are permitted (unless explicitly specified otherwise) to have significantly different nominal diameters, and even when they have the same nominal diameters, generally no two tips will have identical effective diameters. If the CMM software does not correctly handle multiple tip diameters when measuring a single feature, then these five different effective tip diameters may cause increased error values P_{STM} and P_{FTM} , or P_{STN} and P_{FTN} , as relevant.

6.4 Articulating probing systems

6.4.1 Principle

The principle of these tests is to measure the form, size and location of a test sphere using five different angular positions of an articulating probing system (see Figure 6). At each angular position, 25 points are measured on the test sphere, for a total of 125 points using all five positions.

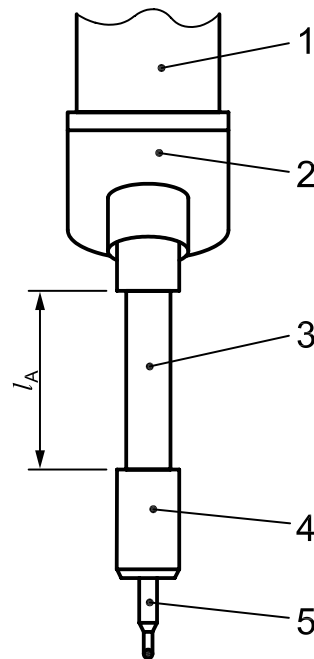

Key

- 1 ram
- 2 articulating probe holder
- 3 probe extension
- 4 probe
- 5 stylus
- l_A probe-tip-offset length

Figure 6 — Articulating probing system in the vertical position

If a stylus- or probe-changing system is supplied with the CMM, perform five changes, one before each of the angular positions used. Associate a least-squares sphere fit with each group of 25 points taken at each angular position, for a total of five sphere fits.

CMMs with articulating probing systems may use either empirical or inferred qualification data for measurement. Therefore, to prevent ambiguity, the maximum permissible errors and limits for a CMM using empirical qualification are labelled $P_{FTE, MPE}$, $P_{STE, MPE}$ and $P_{LTE, MPL}$, while the maximum permissible errors and limits for a CMM using inferred qualification are labelled $P_{FTI, MPE}$, $P_{STI, MPE}$ and $P_{LTI, MPL}$. Similarly, the errors and values obtained when using empirical qualification are labelled P_{FTE} , P_{STE} and P_{LTE} , while the errors and values obtained when using inferred qualification are labelled P_{FTI} , P_{STI} and P_{LTI} .

The ranges of the centre coordinates (X, Y and Z) of all five spheres are calculated. The largest of these three ranges yields the probing-system location value (P_{LTE} or P_{LTI}). In addition, a least-squares sphere fit using all 125 points is examined for the form and size errors of indication. This analysis yields the multi-stylus size error (P_{STE} or P_{STI}) and multi-stylus form error (P_{FTE} or P_{FTI}).

Since the results of these tests are highly dependent on the probe-tip-offset length, a series of tip offset lengths is considered (see Figures 7 and 8), all measured from the centre of rotation of the articulation system. Only those lengths the CMM manufacturer specifies as applicable to the articulating probing system shall be eligible for test.

Articulating probing-system probe-tip-offset length l_A	MPE(P_{FTE}) μm	MPE(P_{STE}) μm	MPL(P_{LTE}) μm
$l_A = 50 \text{ mm}$			
$l_A = 100 \text{ mm}$			
$l_A = 200 \text{ mm}$			
$l_A = 400 \text{ mm}$			

Figure 7 — Sample articulating probing-system specification sheet for empirical qualification

Articulating probing-system probe-tip-offset length l_A	MPE(P_{FTI}) μm	MPE(P_{STI}) μm	MPL(P_{LTI}) μm
$l_A = 50 \text{ mm}$			
$l_A = 100 \text{ mm}$			
$l_A = 200 \text{ mm}$			
$l_A = 400 \text{ mm}$			

Figure 8 — Sample articulating probing-system specification sheet for inferred qualification

Only those probe-tip-offset lengths applicable to the CMM under consideration should be assigned MPE and MPL values in Figures 7 and 8; non-applicable entries may remain blank.

6.4.2 Measuring equipment

The material standard of size, i.e. the test sphere, shall have a diameter not less than 10 mm and not greater than 50 mm. The test sphere shall be calibrated for size and form.

It is recommended that the form error of the test sphere does not exceed 20 % of $P_{FTE, MPE}$ or $P_{FTI, MPE}$, as relevant.

The reference sphere supplied with the CMM for probing-system qualification purposes shall not be used for this test.

6.4.3 Procedure

6.4.3.1 Attach a short (unless otherwise specified, 20 mm), straight stylus to the probe, then attach them to the articulating probing system with a suitable probe-extension component. The applicable values of probe-tip-offset length, l_A , shall be specified by the CMM manufacturer, and shall be chosen from the following values: 50 mm, 100 mm, 200 mm and 400 mm (see Figures 7 and 8). Only one of the offset lengths specified by the CMM manufacturer as applicable to the probing system shall be chosen by the user and tested. The

stylus and probe-extension components shall be those approved for use with the CMM probing system, unless otherwise specified.

However, it is recognized that the exact probe extension lengths required for the test procedures may not be available, and therefore, a probe-tip-offset length variation of 6 mm or 10 % from the nominal value, whichever is greater, is permitted.

6.4.3.2 When testing for $P_{FTE, MPE}$, $P_{STE, MPE}$ and $P_{LTE, MPL}$ is required, qualify the probing system in each of five angular positions in accordance with the CMM manufacturer's normal operating procedures. The five angular positions shall consist of one stylus parallel to the axis of the probe and four styli in a plane perpendicular to the axis, each oriented 90° with respect to those adjacent to it.

On some CMM configurations (e.g. on some horizontal-arm CMMs), some of the above five angular positions may be unattainable or impractical. In such cases, the specified pattern of angular positions should be rotated by $\pm 90^\circ$ about either the X or Y axis, as appropriate to the CMM configuration.

On dual ram CMMs, three of the angular positions should be qualified using one ram, and two of the angular positions using the other ram, all in duplex operating mode (see ISO 10360-2:2009).

6.4.3.3 When testing for $P_{FTI, MPE}$, $P_{STI, MPE}$ and $P_{LTI, MPL}$ is required, then the qualification of the probing system shall be executed in accordance with the CMM manufacturer's normal operating procedure for inferred qualification. The user shall then choose any five widely spaced angular positions of the articulating probing system for this test.

The user is advised to choose angular test positions for inferred qualification which are remote both from those which were used to qualify the articulating system (if known) and from those which were used to qualify the probing system under test.

On dual ram CMMs, three of the angular positions should be qualified using one ram, and two of the angular positions using the other ram, all in duplex operating mode (see ISO 10360-2:2009).

6.4.3.4 One location of the test sphere shall be chosen by the user anywhere in the measuring volume. To avoid interference between the probing system and the reference sphere, the reference sphere may be removed from the table during the test.

The test sphere should be mounted rigidly to minimize errors due to bending.

The location of the test sphere can significantly affect the results. See Annex C for further information.

6.4.3.5 Measure the test sphere using 25 points measured in each angular position, for a total of 125 points.

The points shall be approximately evenly distributed over at least a hemisphere of the test sphere. Their position shall be at the discretion of the user. The recommended point-sampling strategy is the same as for the single-stylus test (see 6.2).

When the support stalk for the test sphere is located on the vertical centre line and a horizontal stylus is used, then access should be optimized by orienting the probing pattern so that each of the eight points on the equator is at 22,5° to a CMM axis and the four points in the adjacent plane are at 45° to the Z axis. This is illustrated in Figure 2, if the lower view is considered to be an elevation.

However, if the test sphere is small relative to its support stalk diameter and/or the stylus tip diameter, so that the eight points on the equator cannot be equispaced at 45° over an arc of 315°, then it is recommended that the eight points are equispaced over the available arc.

At least one articulation shall be made after qualification and before measuring the test sphere, for each of the five angular positions.

If a stylus or probe changing system is supplied with the CMM, all five angular positions of the chosen probing-system assembly (6.4.3.1) shall be qualified, and the stylus or probe returned to the rack, before running this test. Five changes shall be performed during the test, the stylus or probe being returned to the rack after measuring the test sphere in each angular position.

NOTE If the probing-system assembly and one of the angular positions are both identical to those chosen for the single-stylus probing test (6.2), there is no need to make the same measurements twice at that angular position.

6.4.4 Data analysis

6.4.4.1 Associate a least-squares sphere fit with each group of 25 points taken at an angular position, for a total of five sphere fits. Calculate the range of the centre coordinates (X, Y and Z) of all five spheres. The largest of these three ranges yields the probing-system location value, P_{LTE} or P_{LTI} , as relevant.

6.4.4.2 Associate a least-squares sphere fit with all 125 points taken with all five angular positions. Record the absolute value of the deviation of the sphere-fit diameter from the calibrated value of the material standard of size to give the multi-stylus size error P_{STE} or P_{STI} , as relevant. Similarly, record the range of radii of the 125 points with respect to the least-squares sphere centre, i.e. $R_{max} - R_{min}$, the apparent sphere form. The absolute value of this difference is the multi-stylus form error, P_{FTE} or P_{FTI} , as relevant.

NOTE Although just one physical stylus tip is used in these tests, the effective diameter of that tip may not be identical in all five angular positions. If the CMM software does not correctly handle multiple tip diameters when measuring a single feature, then these five different effective tip diameters may cause increased P_{STE} and P_{FTE} , or P_{STI} and P_{FTI} , error values.

7 Compliance with specification

7.1 Acceptance tests

The single-stylus probing performance is verified if the measured single-stylus form error, P_{FTU} , is not greater than the relevant maximum permissible single-stylus form error, $P_{FTU, MPE}$, as specified by the manufacturer and taking into account the uncertainty of measurement according to ISO 14253-1.

When relevant, the multi-stylus probing performance is verified if

- the measured multi-stylus form error, P_{FTj} , is not greater than the relevant maximum permissible multi-stylus form error, $P_{FTj, MPE}$, as specified by the manufacturer and taking into account the uncertainty of measurement according to ISO 14253-1;
- the measured multi-stylus size error, P_{STj} , is not greater than the relevant maximum permissible multi-stylus size error, $P_{STj, MPE}$, as specified by the manufacturer and taking into account the uncertainty of measurement according to ISO 14253-1;
- the measured probing-system location value, P_{LTj} , is not greater than the relevant maximum permissible probing-system location limit, $P_{LTj, MPL}$, as specified by the manufacturer and taking into account the uncertainty of measurement according to ISO 14253-1.

NOTE Evaluation of test uncertainty is discussed in ISO/TS 23165.

If the performance is not verified by all the relevant tests, all probing equipment shall be thoroughly checked for dust, dirt or any operator-induced faults in stylus-system assembly that could be influencing the measurement result, including the critical issue of ensuring that all probing-system components are in thermal equilibrium. Any faults shall be corrected and the relevant test repeated once only, starting from probing-system qualification and using the same target contact points.

7.2 Reverification tests

The single-stylus probing performance is verified if the measured single-stylus form error, P_{FTU} , is not greater than the relevant maximum permissible single-stylus form error, $P_{FTU, MPE}$, as specified by the user and taking into account the uncertainty of measurement according to ISO 14253-1.

When relevant, the multi-stylus probing performance is verified if

- the measured multi-stylus form error, P_{FTj} , is not greater than the relevant maximum permissible multi-stylus form error, $P_{FTj, MPE}$, as specified by the user and taking into account the uncertainty of measurement according to ISO 14253-1;
- the measured multi-stylus size error, P_{STj} , is not greater than the relevant maximum permissible multi-stylus size error, $P_{STj, MPE}$, as specified by the user and taking into account the uncertainty of measurement according to ISO 14253-1;
- the measured probing-system location value, P_{LTj} , is not greater than the relevant maximum permissible probing-system location limit, $P_{LTj, MPL}$, as specified by the user and taking into account the uncertainty of measurement according to ISO 14253-1.

If the performance is not verified by all the relevant tests, all probing equipment shall be thoroughly checked for dust, dirt or any operator-induced faults in stylus-system assembly that could be influencing the measurement result, including the critical issue of ensuring that all probing-system components are in thermal equilibrium. Any faults shall be corrected and the relevant test repeated once only, starting from probing-system qualification and using the same target contact points.

8 Applications

8.1 Acceptance tests

In a contractual situation between a supplier and a customer such as that described in a purchasing, maintenance, repair, renovation or upgrade contract, the acceptance tests described in this part of ISO 10360 may be used to verify the single-stylus probing performance, and (when relevant) the multi-stylus CMM system performance, in accordance with the specified maximum permissible errors and limits agreed on by the supplier and the customer.

8.2 Reverification tests

The reverification tests given in this part of ISO 10360 can be used in an organization's internal quality assurance system for verification of the single-stylus probing performance and (when relevant) the multi-stylus CMM system performance, in accordance with the specified appropriate maximum permissible errors and limits as stated by the user with all possible and detailed limitations applied.

8.3 Interim checks

In an organization's internal quality assurance system, reduced reverification tests can be used periodically to demonstrate the probability that the CMM conforms to the requirements for maximum permissible errors and limits specified in 7.2.

The extent of the interim checks for multi-stylus systems specified in this part of ISO 10360 may be reduced in respect of the number of actual measuring points being assessed.

It is recommended that the probing system be checked regularly, and after any incident which could have significantly affected the probing performance.

9 Indication in product documentation and data sheets

The alternative corresponding indications given in Table 2 are allowed for use in product documentation, drawings, data sheets, etc. Many of the alternatives reduce the amount of small text in subscripts for improved visibility and clarity.

Table 2 — Symbols and corresponding indications

Description	Symbol used in this document	Corresponding indication
Positive constant, expressed in micrometres and supplied by the manufacturer	A	A
Dimensionless positive constant supplied by the manufacturer	K	K
Distance in 3D between the centres of the reference sphere and the test sphere, in millimetres	L_P	L_P
Maximum permissible limit, $P_{FTj, MPE}$, in micrometres, as stated by the manufacturer	B	B
Gaussian radial distance	R	R
Fixed multi-stylus probing-system stylus length	l	l
Single-stylus length	l_U	l_U
Fixed multi-probe-tip-offset length	l_O	l_O
Articulating probing-system probe-tip-offset length	l_A	l_A
Centre coordinates	X, Y, Z	X, Y, Z
Length measurement error with minimal probe-tip-offset length	E_0	E_0
Maximum permissible error of length measurement with minimal probe-tip-offset length	$E_{0, MPE}$	$MPE(E_0)$
Length measurement error with probe-tip-offset length L	E_L	E_L
Maximum permissible error of length measurement	$E_{L, MPE}$	$MPE(E_L)$
Multi-stylus form error, P_{FTj}	P_{FTE}	$PFTE$
	P_{FTI}	$PFTI$
	P_{FTM}	$PFTM$
	P_{FTN}	$PFTN$
Multi-stylus size error, P_{STj}	P_{STE}	$PSTE$
	P_{STI}	$PSTI$
	P_{STM}	$PSTM$
	P_{STN}	$PSTN$
Multi-stylus location error, P_{LTj}	P_{LTE}	$PLTE$
	P_{LTI}	$PLTI$
	P_{LTM}	$PLTM$
	P_{LTN}	$PLTN$
Single-stylus form error	P_{FTU}	$PFTU$
Single-stylus size error	P_{STU}	$PSTU$
Maximum permissible multi-stylus form error, $P_{FTj, MPE}$	$P_{FTE, MPE}$	$MPE(PFTE)$
	$P_{FTI, MPE}$	$MPE(PFTI)$
	$P_{FTM, MPE}$	$MPE(PFTM)$
	$P_{FTN, MPE}$	$MPE(PFTN)$

Table 2 (continued)

Description	Symbol used in this document	Corresponding indication
Maximum permissible multi-stylus size error, $P_{STj, MPE}$	$P_{STE, MPE}$	MPE(<i>PSTE</i>)
	$P_{STI, MPE}$	MPE(<i>PSTI</i>)
	$P_{STM, MPE}$	MPE(<i>PSTM</i>)
	$P_{STN, MPE}$	MPE(<i>PSTN</i>)
Maximum permissible limit of the multi-stylus location value, $P_{LTj, MPL}$	$P_{LTE, MPL}$	MPL(<i>PLTE</i>)
	$P_{LTI, MPL}$	MPL(<i>PLTI</i>)
	$P_{LTM, MPL}$	MPL(<i>PLTM</i>)
	$P_{LTN, MPL}$	MPL(<i>PLTN</i>)
Maximum permissible single-stylus form error	$P_{FTU, MPE}$	MPE(<i>PFTU</i>)

Annex A (informative)

Symbols and subscripts

A.1 Characters listed in position order

Four characters are associated with each MPE, MPL, error and limit value. They are referenced below by their positions, 1 to 4, e.g. error value 1_{234} or MPE/MPL value $1_{234, \text{MPE}}$ or $1_{234, \text{MPL}}$

where the

Character at position 1 indicates the scope of the errors:

P: associated with the **P**robing system

Character at position 2 indicates the type of measuring error:

F: apparent **F**orm error

L: apparent **L**ocation error

S: apparent **S**ize error

Character at position 3 indicates the type of probe used:

T: contacting (i.e. **T**actile) probing

Character at position 4 indicates the type of multiple probing system used:

E: articulating system using **E**mpirical qualification

I: articulating system using **I**nferred qualification

j: any one of E, I, M or N (whichever is relevant)

M: **m**ultiple fixed styli (star)

N: **m**ultiple (i.e. **N**umerous) fixed probes

or, for the single-stylus probing test:

U: single (i.e. **U**nique) stylus

EXAMPLE $P_{\text{FTM, MPE}}$ is the maximum permitted form error when a contacting fixed “star” stylus is used.

Annex B (informative)

Checking the probing system prior to the ISO 10360-2 test

B.1 ISO 10360-2:2009, 6.3.1 recommends that the tests in this part of ISO 10360 be run prior to beginning the extensive testing described in ISO 10360-2, to quickly ensure that the probing system is operating within specifications.

B.2 After running 5.2, check that P_{FTU} is within specification.

B.3 Using the size of the computed Gaussian associated sphere from 6.2.5.1, find the deviation of the sphere fit diameter from the calibrated value of the material standard of size to give the single-stylus size error, P_{STU} .

B.4 If the value of P_{STU} is not adequately small relative to $E_{0, MPE}$ and $E_{L, MPE}$, check the probe system performance and qualification procedure.

B.5 Repeat 5.2, B.2 and B.3 as necessary until a satisfactory result is obtained, before starting the ISO 10360-2 tests.

B.6 There is no separate specified maximum permitted error for P_{STU} , because it is included in E_0 and E_L .

Annex C (informative)

Interpretation of multi-stylus test results

C.1 Comparison of the multi-stylus test results with E_0 and E_L

In ISO 10360-2, each length measurement is made with a single stylus in a single orientation. Therefore, the net distance moved by the CMM in making each measurement is similar to the length measured. Consequently, the length measuring errors found, E_0 and E_L , are typically a function of the measured length, with shorter lengths usually experiencing smaller errors. However, in this part of ISO 10360, most of the measurements are made by CMMs with multiple styli. When multiple styli are used on a workpiece, the net distance moved by the CMM when measuring a short length is not necessarily small, see Figure C.1.

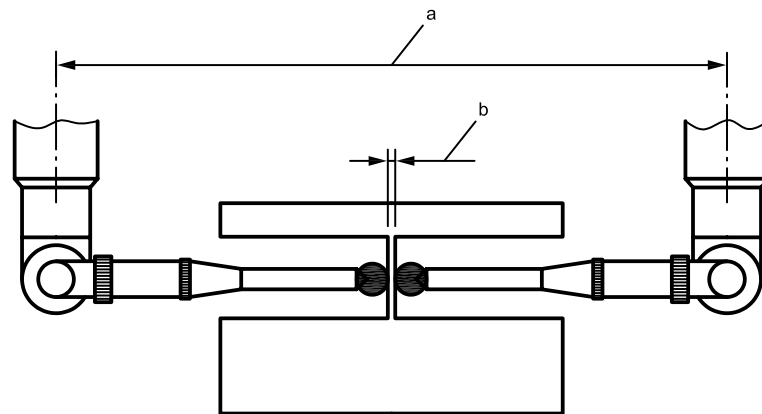

- a CMM travel distance.
- b Measured length.

Figure C.1 — Example of measurement where the measured length is small compared to the CMM travel distance

Therefore, the measuring errors when using multiple styli are not necessarily within the limits defined for E_0 and E_L for the measured length. Closely adjacent features which are measured with different styli may have large errors between them. Also, multiple styli tend to be associated with significant lengths of probe-tip-offset length. These offset lengths may increase the measuring errors, as may be seen by comparing E_0 and E_L .

C.2 Influence of the distance L_P between reference sphere and testing sphere

Due to the geometry errors (including imperfect error compensation) of the CMM, the distance between reference and test sphere can strongly influence the test result. When this distance is small, many CMM errors are corrected/compensated by the qualification procedure and hence the probing-system performance may become dominant. When this distance is large, the geometry errors may become dominant.

Both tests are relevant to workpiece measurement.

The specifications for a small distance L_P represent the performance of the system when measuring small features close to the location of the reference sphere.

The specifications for a large distance L_P represent the performance of the system when measuring small features remote from the location of the reference sphere.

In addition, the test results with small distances may also be the preferred test to compare the multi-stylus probing performance of different probing systems on a CMM, since it is not dominated by the geometry errors of the CMM.

Annex D (normative)

Maximum permissible error/limit figures

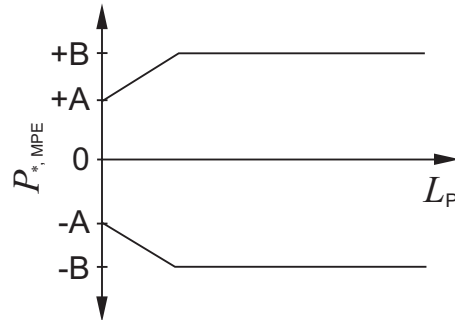

Figure D.1 — Maximum permissible error, P^*, MPE

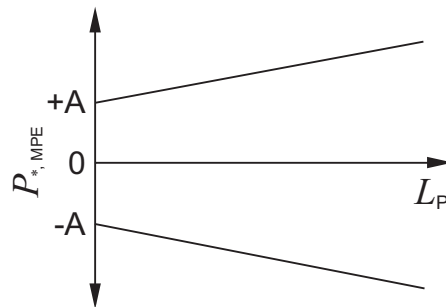

Figure D.2 — Maximum permissible error, P^*, MPE

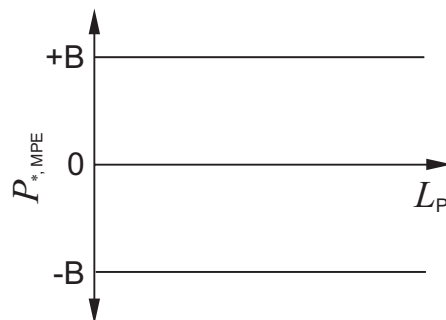

Figure D.3 — Maximum permissible error, P^*, MPE

NOTE 1 Figures for MPLs are identical to the figures shown for MPEs.

NOTE 2 Some MPEs and MPLs are positive only (e.g. for form and location).

Annex E (informative)

Relation to the GPS matrix model

E.1 General

For full details about the GPS matrix model, see ISO/TR 14638.

E.2 Information about this part of ISO 10360 and its use

This part of ISO 10360 specifies the verification methods for proving conformance of coordinate measuring machines with the specified MPEs. The tests given in this part of ISO 10360 are

- applicable to CMMs using contacting probing systems, and
- performed in addition to the length measuring tests given in ISO 10360-2.

When relevant, they are

- a) applicable to CMMs capable of using multiple styli, multiple probes, or multiple articulated probe positions, and are
- b) designed to provide information about the ability of a CMM to measure a feature or features using multiple styli, probes, or articulated probe positions.

E.3 Position in the GPS matrix model

This part of ISO 10360 is a general GPS standard, which influences chain link 5 of the chains of standards on size, distance, radius, angle, form, orientation, location, run-out and datums in the general GPS matrix, as graphically illustrated in Figure E.1.

Fundamental GPS Standards	Global GPS standards						
	General GPS standards						
	Chain link number	1	2	3	4	5	6
	Size					X	
	Distance					X	
	Radius					X	
	Angle					X	
	Form of line independent of datum					X	
	Form of line dependent on datum					X	
	Form of surface independent of datum					X	
	Form of surface dependent on datum					X	
	Orientation					X	
	Location					X	
	Circular run-out					X	
	Total run-out					X	
	Datums					X	
	Roughness profile						
	Waviness profile						
	Primary profile						
	Surface imperfections						
Edges							

Figure E.1 — Position in the GPS matrix model

E.4 Related standards

The related standards are those of the chains of standards indicated in Figure E.1.

Bibliography

- [1] ISO 10360-2:1994, *Coordinate metrology — Part 2: Performance assessment of coordinate measuring machines*
- [2] ISO 10360-2:2001, *Geometrical Product Specifications (GPS) — Acceptance and reverification tests for coordinate measuring machines (CMM) — Part 2: CMMs used for measuring size*
- [3] ISO 10360-3:2000, *Geometrical Product Specifications (GPS) — Acceptance and reverification tests for coordinate measuring machines (CMM) — Part 3: CMMs with the axis of a rotary table as the fourth axis*
- [4] ISO 10360-4:2000, *Geometrical Product Specifications (GPS) — Acceptance and reverification tests for coordinate measuring machines (CMM) — Part 4: CMMs used in scanning measuring mode*
- [5] ISO/TR 14638:1995, *Geometrical product specification (GPS) — Masterplan*
- [6] ISO/TS 23165, *Geometrical product specifications (GPS) — Guidelines for the evaluation of coordinate measuring machine (CMM) test uncertainty*

