

INTERNATIONAL STANDARD

ISO 10333-1

First edition
2000-07-01
AMENDMENT 1
2002-03-15

Personal fall-arrest systems —

Part 1: Full-body harnesses

AMENDMENT 1

Systèmes individuels d'arrêt de chute —

Partie 1: Harnais complet

AMENDEMENT 1



Reference number
ISO 10333-1:2000/Amd.1:2002(E)

© ISO 2002

PDF disclaimer

This PDF file may contain embedded typefaces. In accordance with Adobe's licensing policy, this file may be printed or viewed but shall not be edited unless the typefaces which are embedded are licensed to and installed on the computer performing the editing. In downloading this file, parties accept therein the responsibility of not infringing Adobe's licensing policy. The ISO Central Secretariat accepts no liability in this area.

Adobe is a trademark of Adobe Systems Incorporated.

Details of the software products used to create this PDF file can be found in the General Info relative to the file; the PDF-creation parameters were optimized for printing. Every care has been taken to ensure that the file is suitable for use by ISO member bodies. In the unlikely event that a problem relating to it is found, please inform the Central Secretariat at the address given below.

© ISO 2002

All rights reserved. Unless otherwise specified, no part of this publication may be reproduced or utilized in any form or by any means, electronic or mechanical, including photocopying and microfilm, without permission in writing from either ISO at the address below or ISO's member body in the country of the requester.

ISO copyright office
Case postale 56 • CH-1211 Geneva 20
Tel. + 41 22 749 01 11
Fax + 41 22 749 09 47
E-mail copyright@iso.ch
Web www.iso.ch

Printed in Switzerland

Foreword

ISO (the International Organization for Standardization) is a worldwide federation of national standards bodies (ISO member bodies). The work of preparing International Standards is normally carried out through ISO technical committees. Each member body interested in a subject for which a technical committee has been established has the right to be represented on that committee. International organizations, governmental and non-governmental, in liaison with ISO, also take part in the work. ISO collaborates closely with the International Electrotechnical Commission (IEC) on all matters of electrotechnical standardization.

International Standards are drafted in accordance with the rules given in the ISO/IEC Directives, Part 3.

The main task of technical committees is to prepare International Standards. Draft International Standards adopted by the technical committees are circulated to the member bodies for voting. Publication as an International Standard requires approval by at least 75 % of the member bodies casting a vote.

Attention is drawn to the possibility that some of the elements of this Amendment may be the subject of patent rights. ISO shall not be held responsible for identifying any or all such patent rights.

Amendment 1 to International Standard ISO 10333-1:2000 was prepared by Technical Committee ISO/TC 94, *Personal safety — Protective clothing and equipment*, Subcommittee SC 4, *Personal equipment for protection against falls*.

Personal fall-arrest systems —

Part 1: Full-body harnesses

AMENDMENT 1

Page 5, subclause 4.2.1 b) 3)

Delete "Class L for fall-arrest purposes whilst ladder climbing" and renumber the subsequent item 4) to item 3).

Page 5, subclause 4.2.2

Delete the text and replace it with the following text:

"Class A FBH are designed to support the body during and after the arrest of a fall. They shall have at least one fall-arrest attachment element incorporated. A fall-arrest attachment element shall be positioned so that it lies either at the back of the wearer and centrally between the upper shoulder blades, or centrally at the front of the chest at approximately the height of the sternum."

Page 6, subclause 4.2.5

Delete subclause 4.2.5 and renumber the subsequent subclause.

Page 6, subclause 4.2.6

Renumber this subclause as 4.2.5, delete the text and replace it with the following text:

"Class P FBH are those which meet the requirements for class A FBH and which have an additional attachment element or elements that allow the user to connect into a work-positioning system. Class P FBH shall have at least one work-positioning attachment element incorporated so as to lie at approximately waist level. If only one work-positioning attachment element is provided, it shall lie centrally to the front. If work-positioning attachment elements are provided other than centrally at the front, they shall be placed symmetrically in pairs and shall only be used as a pair, i.e. not separately. Work-positioning attachment elements are not acceptable for connecting into a PFAS."

Page 6, subclause 4.3.2.1

In the first sentence, delete "high tenacity".

In the second sentence, replace "0,5 N/tex" with "0,6 N/tex".

Pages 6 to 8 and 13 to 17, subclauses 4.3.3.1, 4.3.4.3, 4.6.2, 5.4.4 e), 5.4.6, 5.7.1.2, 5.7.1.7, 5.7.2.2, 5.7.2.6, 5.8.3, 5.8.5, 6.2 h)

Replace "attachment points" with "attachment elements".

Page 7, subclause 4.3.4.2

In the second sentence, replace "side attachment points" with "front and side attachment points".

Page 7, subclause 4.3.4.4

In the first sentence, replace "FBH, incorporated" with "FBH, when incorporated".

Page 14, subclause 5.7.1.1

In the third sentence, replace "In addition, position" with "In addition, if the FBH has a dorsal (back) attachment, position".

Page 17, subclause 6.2 a)

Delete the example "ALP".

Page 17, subclause 6.2 h)

In lines 3 and 4, replace "below the back-mounted attachment element above the waist" with "below the fall-arrest attachment and above the waist".

ICS 13.340.99

Price based on 2 pages

© ISO 2002 – All rights reserved

INTERNATIONAL STANDARD

ISO 10333-1

First edition
2000-07-01

Personal fall-arrest systems —

Part 1: Full-body harnesses

Systèmes individuels d'arrêt de chute —

Partie 1: Harnais complet

This material is reproduced from ISO documents under International Organization for Standardization (ISO) Copyright License Number IHS/CC/1996. Not for resale. No part of these ISO documents may be reproduced in any form, electronic retrieval System or otherwise, except written consent of ISO (Case postal 56,1211 Geneva 20, Switzerland, FAX +41 22 734 10 79), IHS or the ISO Licensor's members



Reference number
ISO 10333-1:2000(E)

© ISO 2000

ISO 10333-1:2000(E)

PDF disclaimer

This PDF file may contain embedded typefaces. In accordance with Adobe's licensing policy, this file may be printed or viewed but shall not be edited unless the typefaces which are embedded are licensed to and installed on the computer performing the editing. In downloading this file, parties accept therein the responsibility of not infringing Adobe's licensing policy. The ISO Central Secretariat accepts no liability in this area.

Adobe is a trademark of Adobe Systems Incorporated.

Details of the software products used to create this PDF file can be found in the General Info relative to the file; the PDF-creation parameters were optimized for printing. Every care has been taken to ensure that the file is suitable for use by ISO member bodies. In the unlikely event that a problem relating to it is found, please inform the Central Secretariat at the address given below.

© ISO 2000

All rights reserved. Unless otherwise specified, no part of this publication may be reproduced or utilized in any form or by any means, electronic or mechanical, including photocopying and microfilm, without permission in writing from either ISO at the address below or ISO's member body in the country of the requester.

ISO copyright office
Case postale 56 • CH-1211 Geneva 20
Tel. + 41 22 749 01 11
Fax + 41 22 749 09 47
E-mail copyright@iso.ch
Web www.iso.ch

Printed in Switzerland

Contents

Page

Foreword	iv
Introduction	v
1 Scope	1
2 Normative references	2
3 Terms and definitions	2
4 Requirements	5
5 Test methods	8
6 Instructions for general use, marking, packaging and maintenance	16
Bibliography	19

ISO 10333-1:2000(E)**Foreword**

ISO (the International Organization for Standardization) is a worldwide federation of national standards bodies (ISO member bodies). The work of preparing International Standards is normally carried out through ISO technical committees. Each member body interested in a subject for which a technical committee has been established has the right to be represented on that committee. International organizations, governmental and non-governmental, in liaison with ISO, also take part in the work. ISO collaborates closely with the International Electrotechnical Commission (IEC) on all matters of electrotechnical standardization.

International Standards are drafted in accordance with the rules given in the ISO/IEC Directives, Part 3.

Draft International Standards adopted by the technical committees are circulated to the member bodies for voting. Publication as an International Standard requires approval by at least 75 % of the member bodies casting a vote.

Attention is drawn to the possibility that some of the elements of this International Standard may be the subject of patent rights. ISO shall not be held responsible for identifying any or all such patent rights.

International Standard ISO 10333-1 was prepared by Technical Committee ISO/TC 94, *Personal safety — Protective clothing and equipment*, Subcommittee SC 4, *Personal equipment for protection against falls*.

ISO 10333 consists of the following parts, under the general title *Personal fall-arrest systems*:

- *Part 1: Full-body harnesses*
- *Part 2: Lanyards and energy absorbers*
- *Part 3: Self-retracting lifelines*
- *Part 4: Vertical rails and vertical lifelines which incorporate a sliding-type fall arrester*
- *Part 5: Connectors*

The system performance tests will be the subject of a future part 6 to ISO 10333.

Introduction

In cases where the hazard of falling from a height exists and where, for technical reasons or for work of very short duration, safe access cannot be otherwise provided, it is necessary to consider the use of personal fall-arrest systems (PFAS). Such use should never be improvised and its adoption should be specifically provided for in the appropriate formal provisions for safety in the work place.

PFAS complying with this part of ISO 10333 should satisfy ergonomic requirements and should only be used if the work allows means of connection to a suitable anchor device of demonstrated strength and if it can be implemented without compromising the safety of the user. Personnel should be trained and instructed in the safe use of the equipment and be observant of such training and instruction.

This part of ISO 10333 is based on current knowledge and practice concerning the use of PFAS that incorporate a full-body harness.

This part of ISO 10333 presumes that the manufacturer of the PFAS, subsystems or components will, for the sake of consistency and traceability, operate a quality management system which will comply with national and regional regulations in force at the time. Guidance on the form this quality management system may take can be found in ISO 9000 (all parts), *Quality management and quality assurance standards*.

Personal fall-arrest systems —

Part 1: Full-body harnesses

1 Scope

This part of ISO 10333 specifies the requirements, test methods, instructions for general use, marking, packaging and maintenance for full-body harnesses (FBH).

The main purpose of a FBH is to allow the user to connect into a personal fall-arrest system (PFAS), which will be specified in a future International Standard (see ISO 10333-6 in the Bibliography), such that if an arrest takes place, the arresting force will not exceed 6 kN.

For the purposes of this part of ISO 10333, FBH may have attachment elements that allow the user to connect into other types of safety or access system, for example a work-positioning system, a controlled descent/ascent system or a confined-space access system. This part of ISO 10333 includes requirements for such attachment elements.

This part of ISO 10333 is applicable only to FBH limited to single-person use of a total mass not exceeding 100 kg.

NOTE Users of fall-protection equipment whose total mass (including tools and equipment) exceeds 100 kg are advised to seek advice from the equipment manufacturer regarding the suitability of the equipment, which may need additional testing.

The scope of this part of ISO 10333 does not extend to:

- a) waist belts or chest harnesses: such equipment is not considered as safe to use in personal fall-arrest systems (PFAS);
- b) all other types of harnesses that are not designed primarily for use in PFAS;
- c) other special requirements for FBH, peculiar to use in a controlled descent/ascent system or a confined-space access system;
- d) any assessment of compatibility or suitability in respect of the performance of FBH in a controlled descent/ascent system or a confined-space access system.

This part of ISO 10333 does not specify those additional requirements that would apply when harnesses are subjected to special conditions of use (where, for example, there exist unusual limitations concerning access to the place of work and/or particular environmental factors). Thus treatments to ensure the durability of the materials of construction (such as heat treatment, anti-corrosion treatment, protection against physical and chemical hazards) are not specified in this part of ISO 10333, but should comply with appropriate International Standards or, failing that, with national standards and other specifications dealing with relevant physical characteristics and/or the safety of users. In particular, when it is considered necessary to test the corrosion resistance of metallic parts of the equipment, reference should be made to ISO 9227.

ISO 10333-1:2000(E)**2 Normative references**

The following normative documents contain provisions which, through reference in this text, constitute provisions of this part of ISO 10333. For dated references, subsequent amendments to, or revisions of, any of these publications do not apply. However, parties to agreements based on this part of ISO 10333 are encouraged to investigate the possibility of applying the most recent editions of the normative documents indicated below. For undated references, the latest edition of the normative document referred to applies. Members of ISO and IEC maintain registers of currently valid International Standards.

ISO 9227:1990, *Corrosion tests in artificial atmospheres — Salt spray tests*.

ISO 10333-5:—¹⁾, *Personal fall-arrest systems — Part 5: Connectors*.

World Medical Association Recommendations Guiding Physicians in Biomedical Research Involving Human Subjects (Helsinki Declaration), adopted by the 18th World Medical Assembly, Helsinki, Finland, June 1964 and amended by the 29th World Medical Assembly, Tokyo, Japan, October 1975, 35th World Medical Assembly, Venice, Italy, October 1983, 41st World Medical Assembly, Hong Kong, September 1989 and the 48th General Assembly, Somerset West, Republic of South Africa, October 1996.

3 Terms and definitions

For the purposes of this part of ISO 10333, the following terms and definitions apply.

3.1 Full-body harnesses**3.1.1****full-body harness****FBH**

component of the body-holding device which connects a person into a personal fall-arrest system

See Figure 1.

NOTE 1 The FBH may comprise straps, fittings, buckles or other elements suitably arranged and assembled to support the body of a person and to restrain the wearer during a fall and after the arrest of a fall.

NOTE 2 The FBH may incorporate other fittings which permit its connection into other types of safety systems such as a work-positioning system.

3.1.2**primary strap**

strap of a full-body harness that is intended by the manufacturer to transmit load, and support the body or exert pressure on the body during a fall of the person and after the arrest of a fall

3.1.3**secondary strap**

strap from which the FBH is constructed, other than primary straps

3.1.4**fastening buckle**

two-part fitting designed to facilitate the donning and doffing of a FBH

NOTE 1 The two parts can be coupled and uncoupled; each part is incorporated into mating straps, and when coupled together forms a joint between the mating straps.

NOTE 2 A fastening buckle can be an adjusting buckle.

1) To be published.

3.1.5**adjusting buckle**

fitting designed to facilitate the lengthening or shortening of FBH straps, to provide adjustment for different body sizes and shapes

NOTE An adjusting buckle can be a fastening buckle.

3.1.6**fall-arrest attachment element**

mandatory fitting designated as the point of attachment for the connection into a fall-arrest system

3.1.7**work-positioning attachment element**

optional fitting exclusively designated as the point of attachment for the connection into a work-positioning system

3.1.8**controlled descent/ascent attachment element**

optional fitting exclusively designated as the point of attachment for the connection into a controlled descent/ascent system

3.1.9**confined-space access attachment element**

optional fitting exclusively designated as the point of attachment for the connection into a confined-space access system

3.1.10**collector plate**

slotted plate which allows individual straps to intersect one another, and to be held in this position without being joined

NOTE This also allows independent adjustment, i.e. one strap can be adjusted without affecting the other.

3.1.11**cleat**

retainer which when fitted to straps is designed to gather excess strap length after the process of adjustment has taken place

NOTE This prevents the nuisance and danger of flapping straps interfering with the worker's task.

3.1.12**comfort pad**

extra support fitted to any of the primary straps, which in effect locally increases the strap's width and thickness

NOTE This reduces the pressure exerted on the body by the FBH when in normal or emergency use.

3.1.13**work-positioning back support**

rigid or semi-rigid back support which can be incorporated into a FBH

3.1.14**tool loop**

accessory, usually fitted integrally to the waist strap of a FBH used to attach tools temporarily to the harness while a person is working

3.1.15**total mass**

sum of the user's mass plus all attached clothing and equipment

ISO 10333-1:2000(E)

3.2 Systems

3.2.1

personal fall-arrest system

PFAS

system designed to arrest a fall from a height, to minimize the fall-arrest forces, to control the total fall distance in order to prevent collision with the ground or other obstacle, and to maintain the fallen person in a suitable post-fall attitude

3.2.2

work-positioning system

system that enables a person to work supported by personal protective equipment in tension in such a way that a fall is prevented

3.2.3

controlled descent system

system whereby a worker can descend from one level to another, by rappelling (abseiling) or other method, whilst suspended in an appropriate harness

3.2.4

confined-space access system

system used in a work situation where the worker has to enter into a narrow or confined space using a ladder or by being suspended in a harness, and where emergency evacuation can only be carried out with the worker in a near upright position

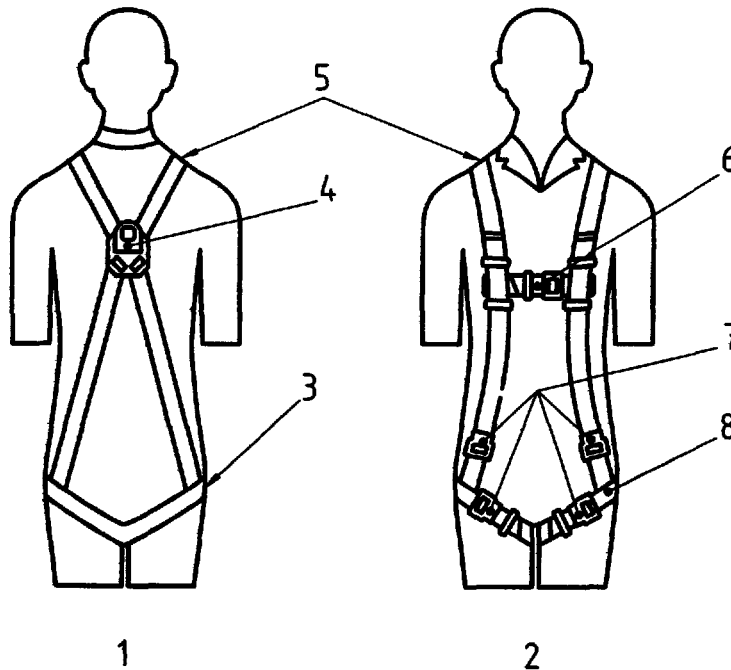

Key

- | | |
|--------------------------|-----------------------------|
| 1 Back | 5 Shoulder straps |
| 2 Front | 6 Shoulder strap restrainer |
| 3 Sub-pelvic strap | 7 Buckles |
| 4 Fall-arrest attachment | 8 Thigh straps |

Figure 1 — Example of a FBH

4 Requirements

4.1 General

To ensure that components assembled into a personal fall-arrest system perform correctly, it is recommended that they be tested in accordance with ISO 10333-6 [1].

FBH may have attachment elements that allow the user to connect into other types of safety or access system, for example a work-positioning system, a controlled descent/ascent system or a confined-space access system.

4.2 Classification

4.2.1 Class identification

This part of ISO 10333 establishes a classification system that specifies the fall-arrest function be mandatory and other functions be optional as follows:

- a) all FBH shall be at least Class A for fall-arrest purposes;
- b) where FBH have optional attachment elements they are classified as follows:
 - 1) Class D for controlled descent/ascent purposes;
 - 2) Class E for confined-space access purposes;
 - 3) Class L for fall-arrest purposes whilst ladder climbing;
 - 4) Class P for work-positioning purposes.

NOTE A FBH may be in more than one class.

4.2.2 Class A — Fall arrest

Class A FBH are designed to support the body during and after the arrest of a fall. They shall have at least one fall-arrest attachment element, incorporated as to lie at the back of the wearer and centrally between the upper shoulder blades.

4.2.3 Class D — Controlled descent/ascent

Class D FBH are those which meet the requirements for Class A FBH and which have additional attachment elements that allow the user to connect into a controlled descent system. Class D FBH shall have the controlled descent/ascent attachment elements incorporated in such locations as to enable the user to adopt an approximate seated position whilst in suspension. Controlled descent/ascent attachment elements are not acceptable for connecting into a PFAS.

4.2.4 Class E — Confined-space access

Class E FBH are those which meet the requirements for Class A FBH and which have additional attachment elements that allow the user to connect into a confined-space access system. Class E FBH shall have a sliding attachment element on each shoulder strap, to be used as a pair, i.e. not separately, so as to enable the user to adopt a near upright position whilst in suspension. Confined-space access attachment elements are not acceptable for connecting into a PFAS.

ISO 10333-1:2000(E)**4.2.5 Class L — Fall arrest (ladder climbing)**

Class L FBH are those which meet the requirements for Class A FBH, and which have an additional fall-arrest attachment element that allows the user to connect into a fall-arrest system necessary for use when climbing. They shall have at least one fall-arrest attachment element, incorporated as to lie at the front of the wearer and centrally between the rib cages.

4.2.6 Class P — Work positioning

Class P FBH are those which meet the requirements for Class A FBH and which have additional attachment elements that allow the user to connect into a work-positioning system. Class P FBH shall have at least two work-positioning attachment elements incorporated as to lie at the waist level at both sides, to be used as a pair, i.e. not separately. Work-positioning attachment elements are not acceptable for connecting into a PFAS.

4.3 Design and construction**4.3.1 General requirements**

4.3.1.1 The purpose of the FBH is to contain the body and to suitably distribute the dynamic fall-arrest forces and post fall-arrest suspension forces over the body. The FBH shall not create any supplementary risk and shall offer an acceptable degree of comfort.

4.3.1.2 A FBH shall comprise an assembly of joined straps, disposed around the pelvic area, legs and shoulders as shown in Figure 1. In addition a waist belt strap and/or a chest strap may be incorporated. A means of adjustment shall be provided to enable the FBH to fit the wearer in accordance with the manufacturer's instructions.

4.3.1.3 The FBH shall be so designed so that when worn, the FBH straps shall be incapable of inadvertently migrating or loosening from their original position or setting.

4.3.1.4 A FBH may be incorporated within a garment.

4.3.1.5 It shall be possible to carry out a visual inspection of the whole FBH, even if incorporated within a garment.

4.3.2 Textile requirements

4.3.2.1 Webbing and yarns shall be made from virgin high tenacity filament, or from multi-filament synthetic fibres suitable for the use intended. The breaking strength of the synthetic fibre shall be known to be at least $0,5 \text{ N/tex}^2$.

4.3.2.2 Primary straps shall have a width of at least 40 mm and secondary straps shall have a width of at least 20 mm. It shall be visually confirmed during the static suspension tests specified in 5.8 which of the straps that support the person are primary and which are secondary.

4.3.2.3 Sewing threads shall be physically compatible with and of a comparable quality to that of the webbing, but shall be of a different colour from that of the webbing in order to facilitate visual inspection.

4.3.3 Requirements for fittings

4.3.3.1 All buckles, attachment points, collector plates, cleats, comfort pads, back support pads and tool loops shall be smoothly finished and free from defects due to faulty material and manufacture; they shall not have sharp or rough edges that may cut, abrade or otherwise damage webbing or cause injury to the user.

2) "tex" is defined as the fibre mass in grams per unit kilometre length of textile.

4.3.3.2 All adjustment buckles shall self-lock securely onto the FBH webbing material but shall not present roughened surfaces or sharp edges that may abrade or otherwise damage the webbing material. Knurled bars are permitted.

4.3.3.3 Fastening buckles shall not be capable of inadvertent uncoupling.

4.3.4 Additional requirements for attachment elements

4.3.4.1 All attachment elements made from loops of textile material shall be adequately protected against abrasion, both inside and outside of the loop.

4.3.4.2 Depending upon FBH classification, attachment elements shall be incorporated into the FBH so as to lie in the positions required in 4.2. Under this part of ISO 10333, side attachment points for connecting into work-positioning systems are not accepted for fall-arrest use.

4.3.4.3 If a FBH is additionally equipped with work-positioning attachment points these shall comply with the relevant standards.

4.3.4.4 The fall-arrest attachment element of a Class A FBH, incorporated as to lie at the back of the wearer and centrally between the upper shoulder blades, shall be so designed as to not slide down the back of the torso test mass during the inverted dynamic test described in 5.7.2.

4.4 Corrosion resistance

When tested in accordance with 5.2, all metallic fittings shall be free of red rust, as visible to the unaided eye, or other evidence of corrosion of the base metal. Post-test presence of white scale is acceptable.

4.5 Buckle uncoupling and slippage

When tested in accordance with 5.3, fastening buckles shall not uncouple, and adjustment buckles shall not allow a strap slippage of more than 25 mm.

4.6 Static strength

4.6.1 The FBH shall withstand a force of 15 kN when tested:

- a) at each fall-arrest attachment element as specified in 5.4;
- b) and where incorporated:
 - 1) at each controlled descent/ascent attachment element as specified in 5.5;
 - 2) at each confined-space access attachment element as specified in 5.6;
 - 3) at each work-positioning attachment element;³⁾
- c) and shall show no:
 - 1) tearing of webbing material;
 - 2) complete separation of any sewn joint;
 - 3) partial or complete fracture of any buckle;
 - 4) inadvertent opening of any fastening buckle.

3) Tests for each work-positioning attachment element will be specified in a future International Standard, presently in the course of preparation, ISO 14566, *Personal equipment for protection against falls — Work-positioning systems*.

ISO 10333-1:2000(E)

4.6.2 Straps and attachment points shall not asymmetrically migrate from position. Straps are allowed to slip through adjustment buckles, but not by more than 25 mm.

4.7 Dynamic performance

4.7.1 The FBH shall retain the torso test mass clear of the ground and in an upright position when tested at each fall-arrest attachment element in accordance with 5.7. In addition, there shall be:

- a) no tearing of webbing material;
- b) no tearing of any primary strap sewn joint;
- c) no partial or complete fracture of any buckle;
- d) no inadvertent opening of any fastening buckle.

4.7.2 At the conclusion of the test the angle formed between the back of the torso test mass and the test lanyard shall not exceed 45°.

4.7.3 The FBH shall be capable of retaining the torso test mass in post-dynamic test suspension for a period of at least 10 min.

4.8 Static suspension test

The FBH shall retain the subject in a position with the head upright when tested at each fall-arrest attachment element in accordance with 5.8. In addition, there shall be:

- a) no metal fittings in contact with the groin, the inside of the thighs or the armpits;
- b) no part of the FBH exerting direct pressure on the genitals, head or neck;
- c) no intense pain felt;
- d) no restriction to normal breathing.

4.9 Static suspension angle test for Class AE FBH

Class AE FBH shall retain the torso test mass in an upright position when tested at each confined-space access attachment element in accordance with 5.9. The angle formed between the back of the torso test mass and the test lanyard shall not exceed 10°.

5 Test methods

5.1 Apparatus

5.1.1 Torso test mass for the static test (see Figure 2), in accordance with the dimensions and requirements specified in Figure 2. The suspension eyebolts should have an inside diameter of 40 mm and maximum cross-section diameter of 16 mm. The surface should be smooth and, if of timber construction, should be shellacked or varnished.

5.1.2 Torso test mass for dynamic test (see Figure 3), constructed of rigid material with hard wood surfaces in contact with the FBH webbing straps as in Figures 3 a) and 3 b) and shall have a mass of (100 ± 1) kg. The included angle between section line A in Figure 3 a) and the shoulder line shall be $(22,5 \pm 5)^\circ$.

Dimensions in millimetres

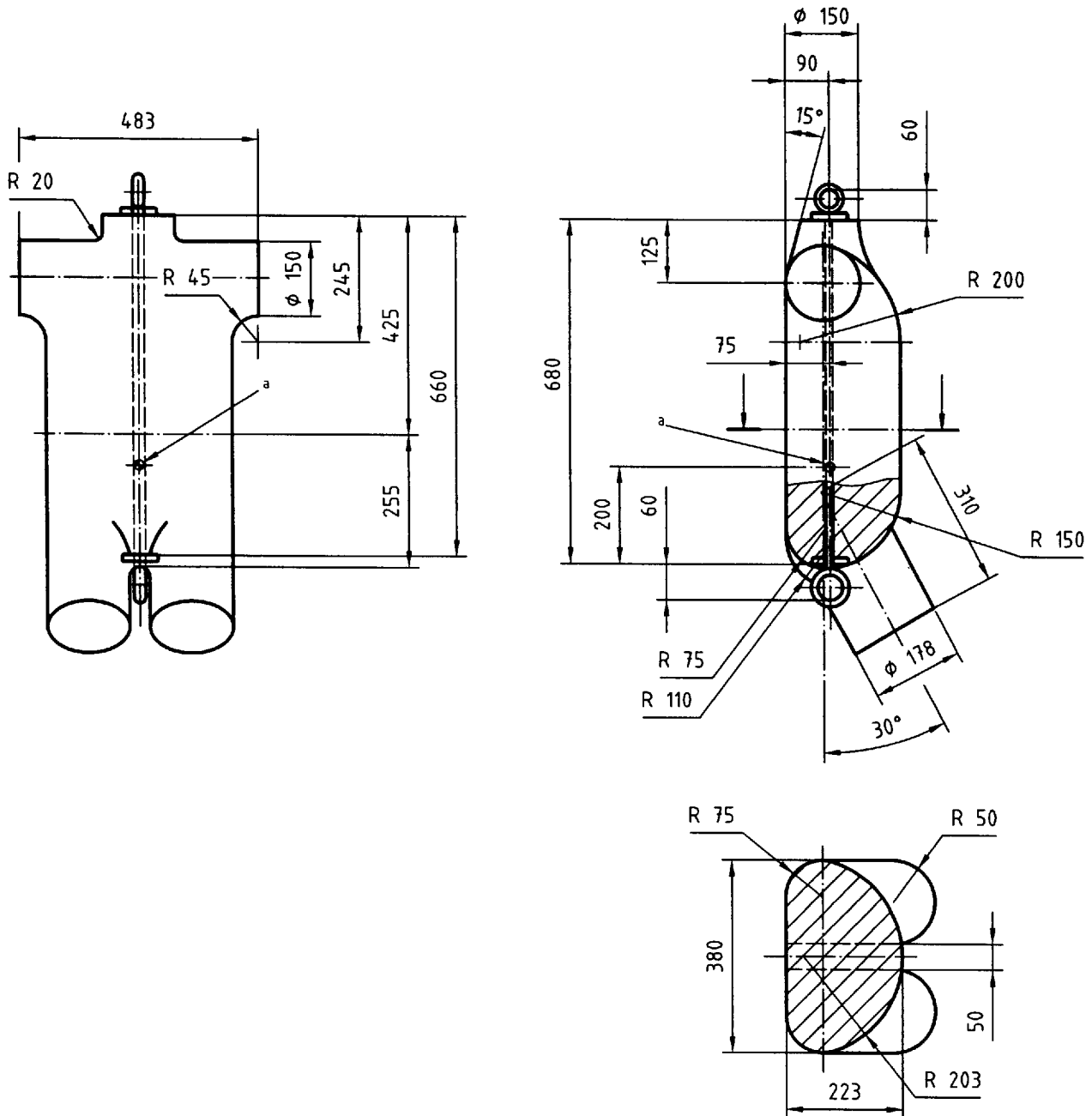

Minimum radius of curvature: R 50

Mass: 100 kg

Material: hardwood or plastics (Shore hardness > 90)

a Centre of gravity

Figure 2 — Torso test mass for static testing

ISO 10333-1:2000(E)

5.1.3 Test lanyard, of wire rope terminated with snap hooks such that the combined length of wire and hooks is $(2\,400 \pm 25)$ mm, measured from snap hook to snap hook bearing points under a tension of 44 N. The lanyard shall be fabricated from type 302 stainless steel in a 9,5 mm diameter, 7 × 19 aircraft cable construction. The lanyard terminations shall be formed by a method which prevents cable slippage.

Dimensions in millimetres

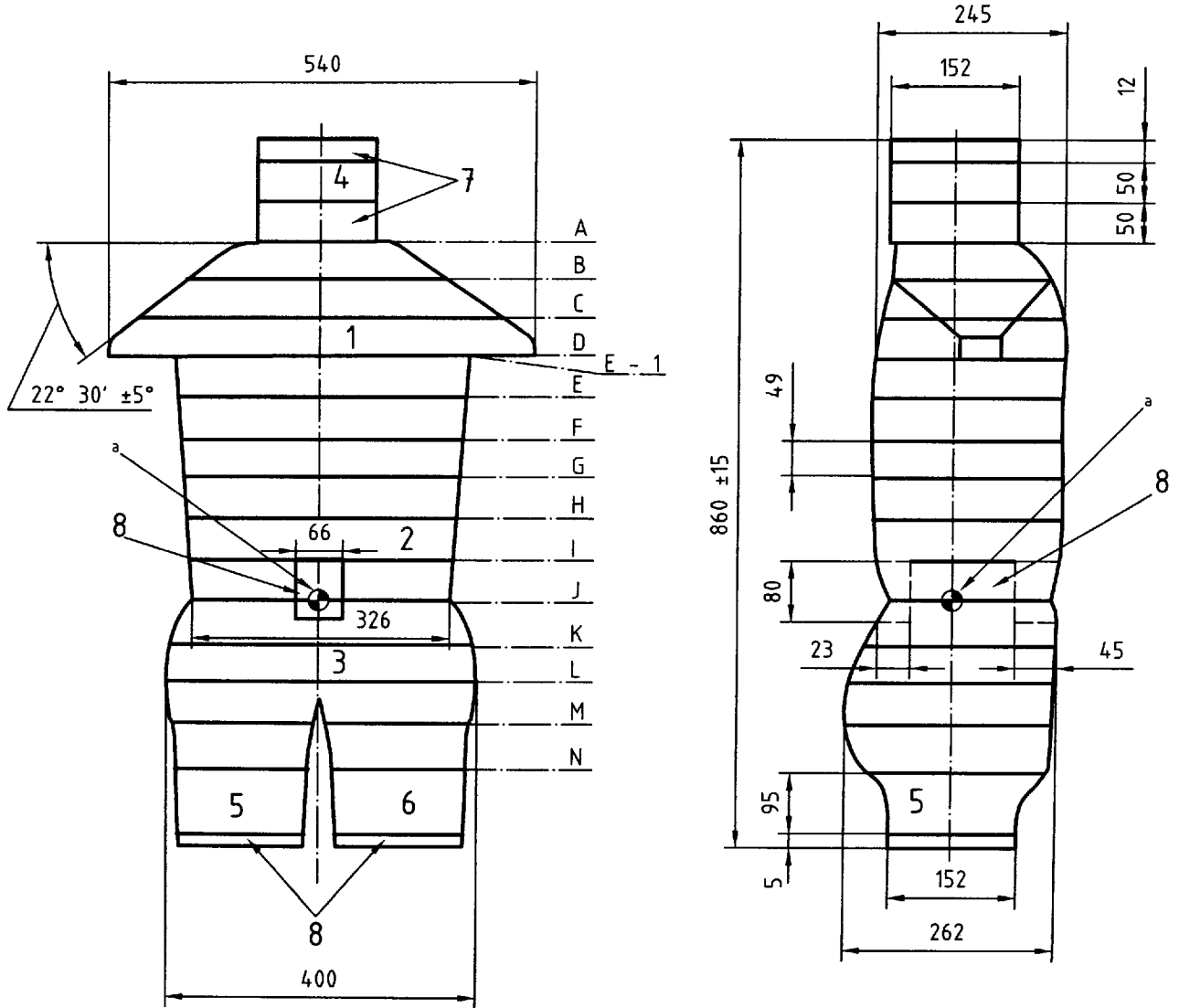

Materials:

Sections 1, 2 and 3: hard wood

Sections 4, 5 and 6: lead

Sections 7 and 8: steel

NOTE Shapes are approximate.

a Centre of gravity

a) Horizontal half-sections of torso test mass

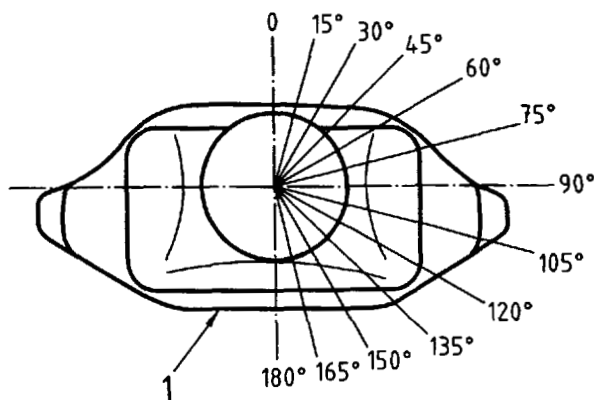

Datum Level	Back													Front
	0°	15°	30°	45°	60°	75°	90°	105°	120°	135°	150°	165°	180°	
A	72	71	77	83	87	85	84	82	86	85	81	78	77	
B	70	72	78	96	135	166	160	165	182	164	134	119	114	
C	92	95	106	130	164	188	245	243	200	182	157	142	138	
D	104	107	117	130	153	178	235	273	213	181	162	144	138	
E-1	105	106	108	117	131	153	175	176	160	148	141	139	138	
E	104	105	108	117	131	153	175	174	159	146	140	138	138	
F	104	105	108	116	130	152	173	174	163	149	142	139	138	
G	102	103	106	114	128	149	170	174	162	149	142	139	138	
H	102	102	106	114	127	146	166	171	161	150	142	139	138	
I	95	98	104	114	127	146	165	169	159	150	145	139	135	
J	71	75	82	101	123	146	163	167	158	151	138	124	122	
I	108	111	121	141	173	192	195	198	190	166	137	123	120	
L	127	131	144	170	193	198	198	201	196	165	137	124	121	
M	—	105	157	173	181	184	185	190	193	167	140	125	—	
N	—	—	120	162	171	181	182	189	186	140	125	—	—	

b) Polar coordinates of horizontal half-sections of torso

Figure 3 — Torso test mass for dynamic testing

5.1.4 Test structure, consisting of the following:

- a) the rigid anchorage structure shall be so constructed that its natural frequency of vibration in the vertical axis at the anchorage point is not less than 100 Hz and so that the application of a force of 20 kN on the anchorage point does not cause a deflection greater than 1 mm;
- b) the rigid anchorage point should be a ring of (20 ± 1) mm bore and (15 ± 1) mm diameter cross-section, or a rod of the same diameter cross-section;
- c) the rigid anchorage point shall be at such a height to prevent the torso test mass from striking the floor during dynamic testing.

ISO 10333-1:2000(E)

5.1.5 Static strength test apparatus, consisting of a test frame, winch or hydraulic puller and indicator, with sufficient traverse to load the torso test mass.

5.1.6 Quick-release device, compatible with the eyebolt of the torso test mass or connectors which ensures the release of the test mass without initial velocity.

5.1.7 Test yoke, consisting of a bar 200 mm long with two connected ropes equal in length and at least 300 mm, constructed as shown in Figure 4. Each rope shall be terminated with a connector. An attachment point for test purposes shall be provided at the centre of the bar.

5.1.8 Force-measuring instrumentation, capable of measuring forces from 1,2 kN to 20 kN with an accuracy of $\pm 2\%$ and withstanding a force of 50 kN without damage, and arranged so that measurements are carried out with a continuously active band up to 100 Hz but with a minimum sampling rate of 1000 Hz.

5.2 Corrosion test

The metallic fittings shall be salt spray tested in accordance with ISO 9227, with an initial exposure of 24 h, followed by 1 h of drying, followed by a second exposure of 24 h.

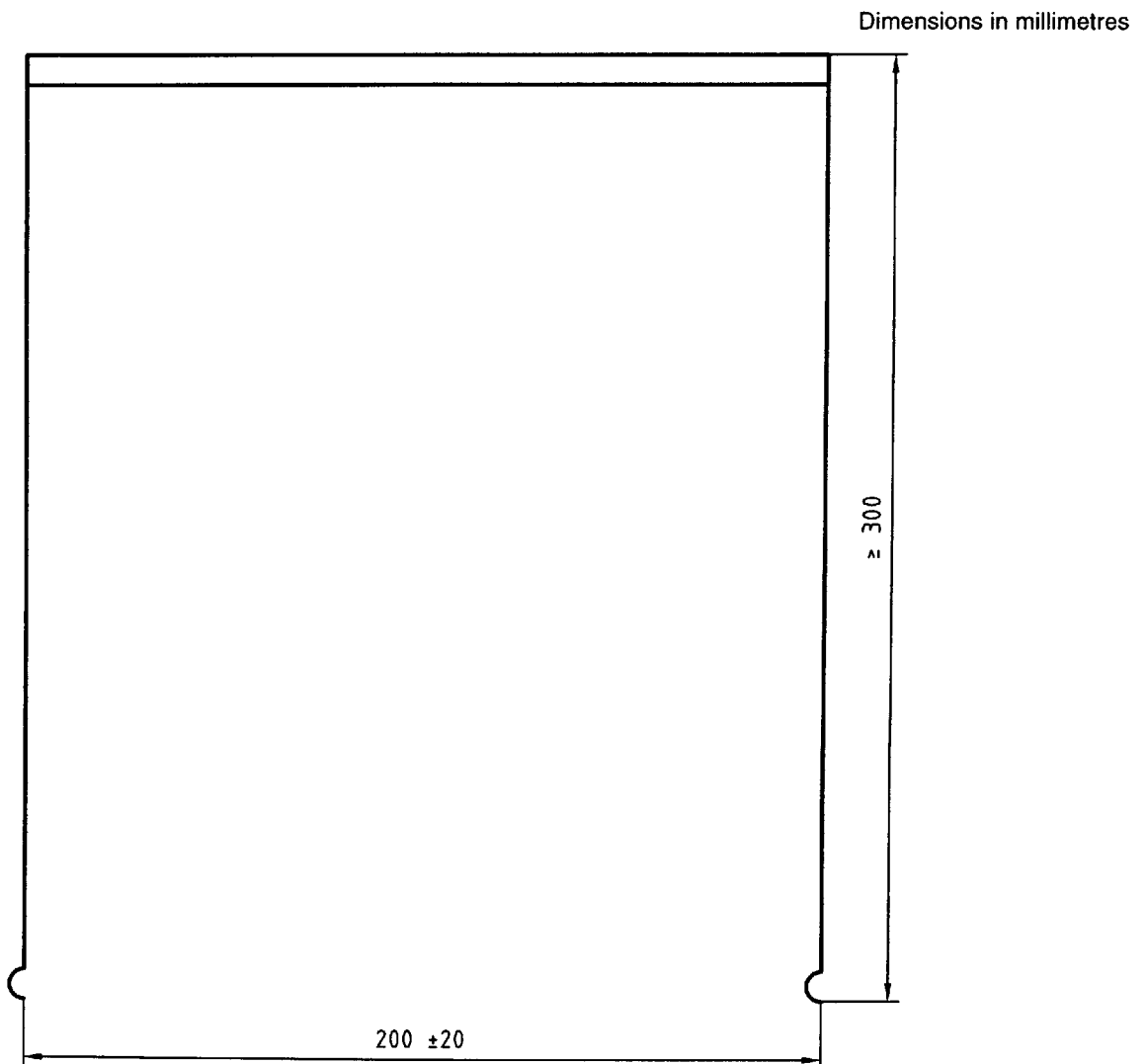

Figure 4 — Test yoke

5.3 Buckle shake test

5.3.1 General

Apply this test to each adjustment buckle and each fastening buckle.

5.3.2 Adjustment buckles

5.3.2.1 Move the webbing through the buckle so that an unset portion of webbing can be tested. Thread the webbing through the buckle in the manner intended by the manufacturer. Mark the webbing in the buckle and the buckle frame so that the marks align.

5.3.2.2 Grasp the webbing on either side of the buckle and shake it quickly by alternatively moving the webbing towards the buckle then away from it for a total of 25 cycles.

5.3.2.3 Observe the alignment marks. Misalignment of the marks indicates webbing slippage. Measure and record any slippage.

5.3.3 Fastening buckles

5.3.3.1 Couple the parts of the buckle together in the manner intended by the manufacturer.

5.3.3.2 Grasp the webbing either side of the buckle and shake it quickly by alternatively moving the webbing towards the buckle and away for a total of 25 cycles.

5.3.3.3 Observe and record whether or not the buckle inadvertently uncouples.

5.4 Static strength test for fall-arrest attachment elements

5.4.1 Fit the FBH to the torso test mass (5.1.1) in a similar manner to that when fitting to a person, in accordance with the manufacturer's instructions. Make all adjustments to ensure a snug fit of the FBH to the torso test mass.

5.4.2 Mark the webbing in each adjustment buckle and buckle frame so that the marks align.

5.4.3 Apply a tensile force of 15 kN between the fall-arrest attachment element and the lower eyebolt of the torso dummy, ensuring that the time to reach this force is (4 ± 1) min. Maintain this force for a period of 3 min.

5.4.4 Observe and record whether there is:

- a) any tearing of webbing material;
- b) any partial or complete separation of any sewn joint;
- c) any partial or complete fracture of any fastening or adjusting buckle;
- d) any inadvertent opening of any fastening buckle;
- e) any asymmetric migration of straps and attachment points from original position;
- f) any misalignment of buckle marks.

5.4.5 Repeat the test for all fall-arrest attachment elements. A new harness may be used in each case.

5.4.6 Repeat the procedures of 5.4.1 to 5.4.5 but by applying the test force between the fall-arrest attachment point and the upper eyebolt of the torso test mass.

ISO 10333-1:2000(E)**5.5 Static strength test for controlled-descent attachment elements**

5.5.1 Fit the FBH to the torso test mass (5.1.1) in a similar manner to that when fitting to a person, in accordance with the manufacturer's instructions. Make all adjustments to ensure a snug fit of the FBH to the torso test mass.

5.5.2 Mark the webbing in each adjustment buckle and buckle frame so that the marks align.

5.5.3 Apply a tensile force of 15 kN between the controlled-descent attachment element and the lower eyebolt of the torso dummy, ensuring that the time to reach this force is (4 ± 1) min. Maintain this force for a period of 3 min. Measure and record in accordance with 5.4.4.

5.6 Static strength test for confined-space access attachment elements

5.6.1 Fit the FBH to the torso test mass (5.1.1) in a similar manner to that when fitting to a person, in accordance with the manufacturer's instructions. Make all adjustments to ensure a snug fit of the FBH to the torso test mass.

5.6.2 Mark the webbing in each adjustment buckle and buckle frame so that the marks align.

5.6.3 Where necessary, attach the connectors of the test yoke ropes to the confined-space access attachment elements. Apply a tensile force of 15 kN between the test yoke and the lower eyebolt of the torso dummy, ensuring that the time to reach this force is (4 ± 1) min. Maintain this force for a period of 3 min. Measure and record in accordance with 5.4.4.

5.7 Dynamic performance tests**5.7.1 "Feet first test"**

5.7.1.1 Fit the FBH to the torso test mass (5.1.2) in a similar manner to that when fitting to a person, in accordance with the manufacturer's instructions. Make all adjustments to ensure a snug fit of the FBH to the torso test mass. In addition, position the uppermost inner surface of the dorsal fall-arrest attachment element to lie (200 ± 20) mm below the flat end of the neck of the torso test mass.

5.7.1.2 Raise the torso test mass in an upright posture, and hold it in position by the quick-release device. Attach one end of the test lanyard to the fall-arrest attachment point under test using a connector complying with ISO 10333-5, and similarly the other end to the test-rig anchorage.

5.7.1.3 Raise the torso test mass so that:

- a) the lifting eyebolt is at a maximum horizontal distance of 300 mm from the vertical axis of the test-rig anchorage before release;
- b) when the quick-release device is operated the torso test mass is allowed to fall freely over a distance of 1,0 m.

5.7.1.4 Release the torso test mass. Observe and record whether there is:

- a) any tearing of webbing material;
- b) any tearing of any primary strap sewn joint;
- c) any partial or complete fracture of any fastening or adjusting buckle;
- d) any inadvertent opening of any fastening buckle.

5.7.1.5 Measure and record the angle formed between the back of the dummy and the test lanyard.

5.7.1.6 Leave the torso test mass in post-drop test suspension for a period of at least 10 min and observe that the torso test mass is retained.

5.7.1.7 Repeat the procedures 5.7.1.1 to 5.7.1.6 for each fall-arrest attachment point, using a new FBH and test lanyard in each case.

5.7.2 “Head first test”

5.7.2.1 Repeat the procedure in 5.7.1.1 using a new FBH.

5.7.2.2 Raise the torso test mass (5.1.2) in an inverted posture, and hold it in position by the quick-release device. Attach one end of a new test lanyard to the fall-arrest attachment point under test using a connector complying with ISO 10333-5, and similarly the other end to the test-rig anchorage.

5.7.2.3 Lower the torso test mass until the test lanyard is straight, without loading the FBH. Ensure that the attachment element under test is pointing upwards.

5.7.2.4 Raise the torso test mass so that:

- a) the lifting eyebolt is at a maximum horizontal distance of 300 mm from the vertical axis of the test-rig anchorage before release;
- b) when the quick-release device is operated the torso test mass is allowed to fall freely over a distance of 1,0 m.

At the end of the free fall the torso test mass will pivot about the fall-arrest attachment element. Therefore, a greater clearance will be required than that in the “feet first test”.

5.7.2.5 Release the torso test mass. Observe and record in accordance with the procedures given in 5.7.1.4 to 5.7.1.6.

5.7.2.6 Repeat the procedures 5.7.2.1 to 5.7.2.5 for each fall-arrest attachment point, using a new FBH and test lanyard in each case.

5.8 Static suspension test for fall-arrest attachment elements

5.8.1 The test is to be carried out with a minimum of three people who are within the stature height range of 1,6 m to 1,9 m. Medical supervision shall be made available as a safety precaution during the tests in accordance with the Helsinki Declaration. If any person reports extreme pain during testing, the tests shall be stopped immediately.

NOTE There is no set duration for each test since the purpose of the test is to detect obvious design defects only.

5.8.2 Attach the FBH to the first test participant in accordance with the manufacturer’s instructions. Make all adjustments to ensure a snug fit.

5.8.3 Attach one end of the test lanyard to the fall-arrest attachment point using a connector complying with ISO 10333-5, and similarly the other end to an anchorage which is capable of supporting the test participant’s mass with a safety factor of at least 10. This anchorage should be at a position so that the test participant can be freely suspended with the feet just clear of the test-rig floor. This can be achieved by raising the test participant with a winch. The clearance between the feet and floor shall not exceed 100 mm.

5.8.4 With the test participant clear of the test floor, observe and record whether there is:

- a) any metal fittings in contact with the groin, the inside of the thighs or the armpits;
- b) any part of the FBH exerting direct pressure on the genitals, head or neck;
- c) any intense pain felt;
- d) any restriction to normal breathing.

ISO 10333-1:2000(E)

5.8.5 Repeat the procedures described in 5.8.2 to 5.8.4 for each fall-arrest attachment point.

5.8.6 Repeat the procedures described in 5.8.2 to 5.8.5 for the remaining test participants.

5.9 Static suspension angle test for Class AE FBH

5.9.1 Fit the FBH to the torso test mass (5.1.2) in a similar manner to that when fitting to a person, in accordance with the manufacturer's instructions. Make all adjustments to ensure a snug fit of the FBH to the torso test mass.

5.9.2 Where necessary, attach the connectors of the test yoke ropes to the confined-space access attachment elements.

5.9.3 Raise the torso test mass so that it is just clear of the floor. Allow the torso test mass to remain suspended for 3 min, and then measure and record the angle between the back of the torso test mass and the test yoke ropes.

6 Instructions for general use, marking, packaging and maintenance**6.1 Instructions for general use and maintenance**

Clear instructions in the appropriate national language, for fitting, adjustment and use shall be supplied with each FBH. Such instructions shall also include the following information:

- a) the name of the manufacturer;
- b) where appropriate, the name and address of the supplier or such other information as enables the supplier to be traced;
- c) a statement of the purposes and limitations of the FBH. Also that it should only be issued for use, when it is known that it will be part of a PFAS which will ensure that should an arrest take place, the arrest force will not exceed 6 kN and the arrest distance will be controlled;
- d) a warning against making any alterations or additions to the product;
- e) in cases where securing buckles (i.e. buckles other than those used primarily for adjustment of fit) are capable of assembly in more than one way, instructions of the method of assembly by which the harness complies with this part of ISO 10333 and a warning against the use of any other methods of assembly;
- f) a warning against the danger that may arise by the use of combinations of components and/or sub-system in which the safe function of any one component and/or sub-system is affected by, or interferes with, the safe function of another;
- g) an instruction to make a visual inspection of the equipment immediately before use and to ensure that the equipment is in a serviceable condition and operates correctly;
- h) advice or limitations of the materials in the product which may affect its performance, for example temperature, the effect of sharp edges, chemical reagents, cutting, abrasion, UV degradation and that the user should consult the manufacturer in case of doubt;
- i) storage instructions;
- j) instructions for cleaning and/or washing;
- k) instructions for maintenance;
- l) advice that the equipment is to be inspected periodically, taking account of the conditions of use, and at least once a year, by a competent person according to the manufacturer's instructions;

- m) a warning that repairs to the equipment be carried out only by the manufacturer or by a competent person appropriately authorized by the manufacturer;
- n) guidance concerning the inspection of the equipment and those factors that should cause the equipment to be discarded;
- o) an instruction that any equipment that has been used to arrest a fall be removed from service;
- p) an instruction that any work-positioning attachment elements mounted at the side waist positions shall not be used for connecting into a PFAS;
- q) advice that before and during use, consideration should be given as to how any rescue of a user in post fall-arrest suspension can be safely and efficiently carried out.

6.2 Marking

FBH shall be clearly and indelibly marked or permanently labelled by any suitable method not having a harmful effect on materials with the following information:

- a) the number of this part of ISO 10333 (i.e. ISO 10333-1), its type, and its class (for example A, AD, ADP, ALP, etc.);
- b) the name, trade mark or other means of identification of the manufacturer or the supplier who is responsible for acting on behalf of the manufacturer of the product for claiming compliance with this part of ISO 10333 (i.e. ISO 10333-1);
- c) the manufacturer's product identification information that shall include the manufacturer's batch or serial number that enables the origin of the item to be traced;
- d) the year of manufacture of the product;
- e) the identity of the fibre used as the material of construction;
- f) all information stating by appropriate means the intended purpose of each attachment element and specifically identifying those attachment elements that are designed to be used as part of a complete fall-arrest system (see 4.2);
- g) a warning to read the manufacture's instructions;
- h) a special marking indicating the attachment point for a fall-arresting application. The letter "A", at least 3 cm in length and width and the width of each character stroke at least 0,5 cm, shall be marked on each shoulder strap below the back-mounted attachment element above the waist (Figure 5). An arrow "↑" at least 5 cm in length and 3 cm in width and at least a 1 cm wide character stroke shall be marked on each shoulder strap immediately above or adjacent to the letter "A", pointing in the direction of the attachment element (see Figure 5). All lettering shall be in a prominent contrasting colour.

6.3 Packaging

Each harness shall be supplied wrapped but not necessarily sealed in moisture-proof material.

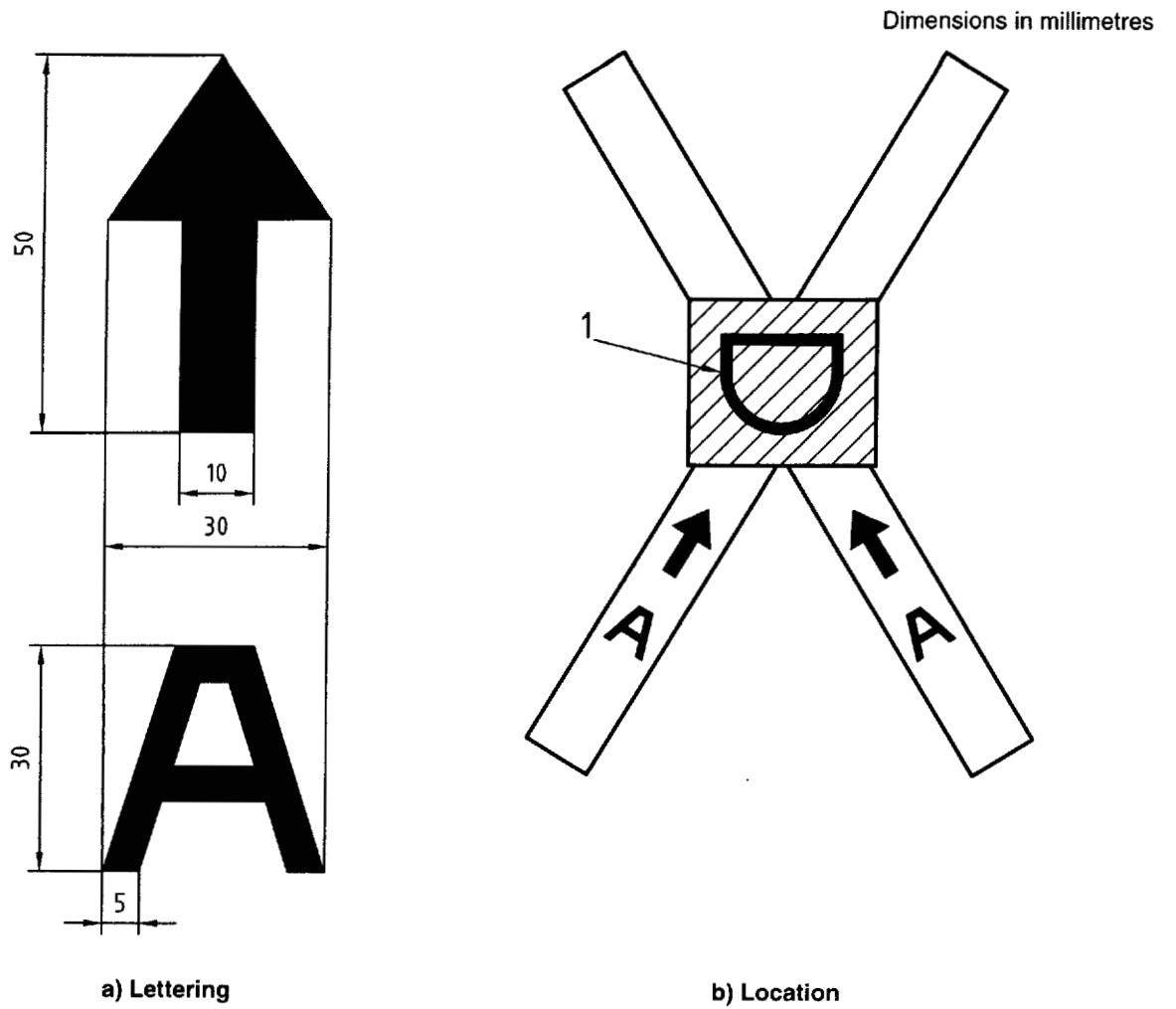

Key

- 1 Fall-arrest attachment D-ring

Figure 5 — Special marking for the fall-arrest attachment element

Bibliography

- [1] ISO 10333-6:—⁴⁾, *Personal fall-arrest systems — Part 6: Systems performance tests*.

4) In preparation. Further information may be obtained from Technical Committee ISO/TC 94, Subcommittee 4.

ISO 10333-1:2000(E)

ICS 13.340.99

Price based on 19 pages

© ISO 2000 – All rights reserved