

---

---

**Petroleum products — Total sediment in  
residual fuel oils —**

Part 2:  
**Determination using standard procedures  
for ageing**

*Produits pétroliers — Insolubles existants dans les fuel-oils résiduels —*

*Partie 2: Détermination à l'aide de méthodes de vieillissement de  
référence*



**PDF disclaimer**

This PDF file may contain embedded typefaces. In accordance with Adobe's licensing policy, this file may be printed or viewed but shall not be edited unless the typefaces which are embedded are licensed to and installed on the computer performing the editing. In downloading this file, parties accept therein the responsibility of not infringing Adobe's licensing policy. The ISO Central Secretariat accepts no liability in this area.

Adobe is a trademark of Adobe Systems Incorporated.

Details of the software products used to create this PDF file can be found in the General Info relative to the file; the PDF-creation parameters were optimized for printing. Every care has been taken to ensure that the file is suitable for use by ISO member bodies. In the unlikely event that a problem relating to it is found, please inform the Central Secretariat at the address given below.



**COPYRIGHT PROTECTED DOCUMENT**

© ISO 2009

All rights reserved. Unless otherwise specified, no part of this publication may be reproduced or utilized in any form or by any means, electronic or mechanical, including photocopying and microfilm, without permission in writing from either ISO at the address below or ISO's member body in the country of the requester.

ISO copyright office  
Case postale 56 • CH-1211 Geneva 20  
Tel. + 41 22 749 01 11  
Fax + 41 22 749 09 47  
E-mail [copyright@iso.org](mailto:copyright@iso.org)  
Web [www.iso.org](http://www.iso.org)

Published in Switzerland

## Foreword

ISO (the International Organization for Standardization) is a worldwide federation of national standards bodies (ISO member bodies). The work of preparing International Standards is normally carried out through ISO technical committees. Each member body interested in a subject for which a technical committee has been established has the right to be represented on that committee. International organizations, governmental and non-governmental, in liaison with ISO, also take part in the work. ISO collaborates closely with the International Electrotechnical Commission (IEC) on all matters of electrotechnical standardization.

International Standards are drafted in accordance with the rules given in the ISO/IEC Directives, Part 2.

The main task of technical committees is to prepare International Standards. Draft International Standards adopted by the technical committees are circulated to the member bodies for voting. Publication as an International Standard requires approval by at least 75 % of the member bodies casting a vote.

Attention is drawn to the possibility that some of the elements of this document may be the subject of patent rights. ISO shall not be held responsible for identifying any or all such patent rights.

ISO 10307-2 was prepared by Technical Committee ISO/TC 28, *Petroleum products and lubricants*.

This second edition cancels and replaces the first edition (ISO 10307-2:1993), which has been technically revised.

ISO 10307 consists of the following parts, under the general title *Petroleum products — Total sediment in residual fuel oils*:

- *Part 1: Determination by hot filtration*
- *Part 2: Determination using standard procedures for ageing*

## Introduction

Experience has shown that the precipitation of asphaltenes from a residual fuel oil in the form of sediment can occur during storage and handling. Such sediment can cause severe difficulties, and in extreme cases can render the fuel unfit for use. Once out of solution, it is extremely difficult to reprecipitate the asphaltenes into their original state.

Fuel pre-treatment designed to accelerate the ageing/sedimentation process, followed by filtration, is a well-established technique for testing whether sediment from residual fuel oils will precipitate during storage and handling. This could involve thermal ageing (heating to a specified temperature for a specified time) or chemical ageing (addition of a specified amount of a normal alkane to test whether the balance between the required aromaticity of the asphaltenes and the available aromaticity of the oil phase is disturbed to the extent that asphaltene precipitation occurs).

A means of predicting the presence of a reserve of stability to sedimentation in residual fuel oil during storage and handling is thus a useful tool in the petroleum products industry.

# Petroleum products — Total sediment in residual fuel oils —

## Part 2:

## Determination using standard procedures for ageing

**WARNING** — The use of this part of ISO 10307 could involve hazardous materials, operations and equipment. The document does not purport to address all of the safety problems associated with its use. It is the responsibility of the user of this part of ISO 10307 to establish appropriate safety and health practices, and determine the applicability of regulatory limitations prior to use.

### 1 Scope

This part of ISO 10307 specifies two procedures — A (thermal) and B (chemical) — for the accelerated ageing of residual fuel oils. When combined with the hot filtration method specified in ISO 10307-1, these procedures permit the prediction of fuel oil stability, as affected by sedimentation, during storage and handling of the fuel oils.

NOTE For the purposes of this International Standard, the terms “% ( $m/m$ )” and “% ( $V/V$ )” are used to represent mass and volume fractions of a material, respectively. These expressions are deprecated under the International System and according to ISO 31-0, *Quantities and units — Part 0: General principles*, which specifies that mass and volume fractions be expressed as “mass fraction of xx %” (symbol  $\omega$ ) and “volume fraction of xx %” (symbol  $\varphi$ ).

### 2 Normative references

The following referenced documents are indispensable for the application of this document. For dated references, only the edition cited applies. For undated references, the latest edition of the referenced document (including any amendments) applies.

ISO 1773:1997, *Laboratory glassware — Narrow-necked boiling flasks*

ISO 10307-1:2009, *Petroleum products — Total sediment in residual fuel oils — Part 1: Determination by hot filtration*

### 3 Terms and definitions

For the purposes of this document, the following terms and definitions apply.

#### 3.1

##### **potential total sediment**

total sediment, determined by ISO 10307-1, after ageing a sample of residual fuel for 24 h at 100 °C under prescribed conditions

#### 3.2

##### **accelerated total sediment**

total sediment, determined by ISO 10307-1, after dilution of a sample of residual fuel with hexadecane in the ratio of 1 ml per 10 g of sample under carefully controlled conditions, followed by storage for 1 h at 100 °C

## 4 Principle

### 4.1 General

The total sediment is determined after accelerated ageing in accordance with either 4.2 or 4.3, followed by hot filtration in accordance with ISO 10307-1. The ageing is carried out in duplicate (see Note to 8.1).

### 4.2 Thermal ageing (Procedure A)

A sample of residual fuel oil is subject to ageing at 100 °C for 24 h under specified conditions.

### 4.3 Chemical ageing (Procedure B)

A sample of residual fuel oil is diluted with a specified amount of hexadecane (cetane) under carefully controlled conditions. It is then heated to 100 °C for 1 h.

## 5 Apparatus

**5.1 Ageing bath**, comprising an electrically heated oil bath, capable of maintaining a temperature of 100 °C ± 0,5 °C, fitted with air wells of inner dimension 55 mm and depth 120 mm, as illustrated in Figure 1.

**5.2 Ageing bath temperature-measuring device**, capable of measuring the temperature in the range from 95 °C to 103 °C with an accuracy of 0,5 °C (see Figure 1).

**5.3 General-purpose temperature-measuring device**, capable of measuring the temperature in the range from 0 °C to 100 °C with an accuracy of 0,5 °C.

**5.4 Air condenser**, glass, of outer diameter 8 mm and length 400 mm.

NOTE The air condenser preferably matches the conical flask (5.9). Alternatively, the air condenser can be attached by means of a cork, bored to accommodate the air condenser.

**5.5 Stoppers**, to provide a tight fit in the test jar.

**5.6 Microburette**, of minimum capacity 5 ml, graduated in 0,02 ml subdivisions or less.

**5.7 Magnetic stirrer/hotplate**, capable of being controlled by a surface-temperature-measuring device, (see 5.8), and with polytetrafluoroethylene (PTFE)-coated stirring bars, length 25 mm.

**5.8 Surface-temperature-measuring device**, capable of measuring the temperature up to 200 °C.

**5.9 Conical flask**, 50 ml capacity, narrow neck, complying with ISO 1773.

**5.10 Spatula**, of polypropylene, chamfered ends, 200 mm long.

**5.11 Stirring rod**, glass or PTFE (polytetrafluoroethylene), approximately 150 mm long and 3 mm in diameter.

**5.12 Hexadecane distribution funnel**, of borosilicate glass, capacity 5 ml to 10 ml, outlet orifice 0,4 mm ± 0,02 mm diameter.

NOTE Standard funnels meeting the above criteria are available commercially.

**5.13 Portable warm air blower**, for heating the microburette to 20 °C minimum, if required.

**5.14 High-speed mixer**, of any convenient type with a minimum speed of 400 rev/min.

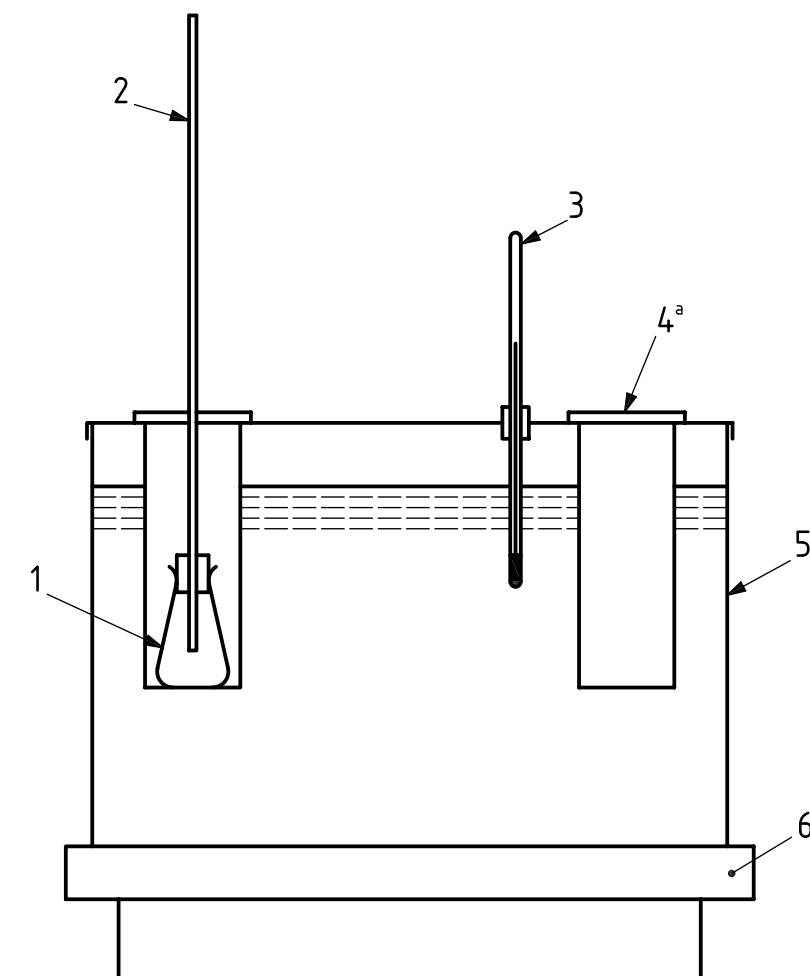
**Key**

- 1 test flask
- 2 air condenser
- 3 temperature-measuring device
- 4 air well
- 5 oil bath
- 6 hotplate or immersion heater

<sup>a</sup> For well dimensions, see 5.1.

**Figure 1 — Ageing bath**

## 6 Reagent

**6.1 Hexadecane (cetane)**, commercial-grade normal hexadecane of 99 % purity, minimum.

As hexadecane starts to solidify at approximately 18 °C, store the bulk quantity at or above 20 °C, or bring to this minimum temperature before use.

NOTE Portable warm air blowers and/or water baths not more than 50 °C are suitable for raising the temperature of the microburette or bulk hexadecane container.

## 7 Sampling and sample preparation

Follow the instructions given in ISO 10307-1:2009, Clauses 7 and 8.

## 8 Ageing procedures

### 8.1 General

Prepare the filters in accordance with ISO 10307-1:2009, Clause 9.

Carry out the ageing procedure on duplicate aliquots.

NOTE The term “duplicate” as used in ISO 10307-1 has a specific meaning. ISO 10307-1 requires that a result be reported as the average of duplicate determinations. In order to facilitate this, and in order to ensure homogeneity, two aliquots are aged using the procedure given below, and each aliquot is tested once for sediment determination by hot filtration.

### 8.2 Procedure A — Sediment determination using thermal ageing

**8.2.1** Pour a  $25\text{ g} \pm 1\text{ g}$  aliquot of the homogenized sample into the conical flask (5.9), attach the air condenser (5.4), and place the sample in the well of the ageing bath (5.1) at  $100\text{ }^{\circ}\text{C} \pm 0,5\text{ }^{\circ}\text{C}$  for  $24\text{ h} \pm 15\text{ min}$ .

**8.2.2** Remove the flask from the bath, replace the air condenser with the stopper (5.5), and shake vigorously until all the sludge has been uniformly suspended. To check this, invert the flask and examine the bottom and walls of the flask for any sludge deposits, after allowing the oil to drain down from the inside walls of the flask. Remove stubborn deposits from the walls or bottom of the conical flask by scraping with the spatula (5.10). Re-shake and within 1 min initiate the procedure specified in ISO 10307-1:2009, Clause 10, for sediment determination by hot filtration.

### 8.3 Procedure B — Sediment determination using chemical ageing

**8.3.1** Heat the stirrer/hotplate to a surface temperature corresponding to the temperature at which the sample under investigation has a kinematic viscosity of approximately  $50\text{ mm}^2/\text{s}$ .

NOTE (Local) overheating of the sample should be avoided when placed on a hotplate. Overheating can cause sample decomposition processes. Proper sample temperature control is therefore important. Placing the flask in a metal block, which is placed on the magnetic stirrer/hotplate, is found suitable.

**8.3.2** Weigh  $25\text{ g} \pm 0,2\text{ g}$  of the homogenized sample into the conical flask and add a PTFE-coated stirring bar. Place the flask in the centre of the stirrer/hotplate controlled as described in 8.3.1 (see Note above) and adjust the stirring speed to approximately 200 r/min. After 10 min, slowly add  $2,5\text{ ml} \pm 0,02\text{ ml}$  of hexadecane (6.1) from the microburette (5.6) to the flask at a maximum rate of 1,0 ml/min, while continuously stirring.

Asphaltenes that are flocculated during the addition of hexadecane owing to lack of homogeneity are not easily peptized afterwards and can produce faulty results. Therefore, it is imperative that local over-dilution does not occur during the addition step. This is dependent on the maximum rate of addition, which can be controlled by positioning the microburette above a funnel (5.12), discharging the  $2,5\text{ ml} \pm 0,02\text{ ml}$  directly into the funnel neck and allowing the hexadecane to drip into the stirred sample by gravity. Direct addition of the hexadecane from the microburette is not recommended, but if carried out it is essential that the orifice diameter of the microburette not exceed 1,0 mm, and that the overall tip diameter not exceed 5,0 mm.

NOTE The rate of mass addition can be determined by plotting mass transferred as calculated from the volume delivered by the burette (hexadecane density at  $20\text{ }^{\circ}\text{C}$  is  $773,4\text{ kg/m}^3$ ) against time of delivery.

**8.3.3** Pour the sample and hexadecane mixture into a fresh 50 ml flask and attach the air condenser. Place the flask in the well of the oil bath at  $100\text{ }^{\circ}\text{C} \pm 0,5\text{ }^{\circ}\text{C}$ . Allow the flask to remain in the bath for  $60\text{ min} \pm 2\text{ min}$ .



**8.3.4** Remove the flask from the bath, replace the air condenser with the stopper (5.5) and shake vigorously until all the sludge has been uniformly suspended. To check this, invert the flask and examine the bottom and walls of the flask for any sludge deposits, after allowing the oil to drain down from the inside walls of the flask. Remove stubborn deposits from the walls or bottom of the flask by scraping with the spatula. Re-shake and within 1 min initiate the procedure specified in ISO 10307-1:2009, Clause 10, for sediment determinations by hot filtration.

## 9 Expression of results

**9.1** Calculate the mass percentage of total sediment for each test specimen using Equation (1):

$$S = \frac{(m_5 - m_4) - (m_3 - m_2)}{10m_1} \quad (1)$$

where

- $S$  is the total sediment, expressed as percentage by mass;
- $m_1$  is the mass of the test portion, expressed in grams;
- $m_2$  is the mass of the lower filter before filtration, expressed in milligrams;
- $m_3$  is the mass of the lower filter after filtration, expressed in milligrams;
- $m_4$  is the mass of the upper filter before filtration, expressed in milligrams;
- $m_5$  is the mass of the upper filter after filtration, expressed in milligrams.

For each test specimen with a calculated total sediment concentration  $> 0,005 \% (m/m)$  as determined by Equation (1), record the mass percentage of total sediment to the nearest  $0,01 \% (m/m)$ .

For each test specimen with a total sediment concentration  $\leq 0,005 \% (m/m)$ , record the result as  $0,005 \% (m/m)$ .

**9.2** Report the *potential total sediment* by hot filtration as the average of the duplicate determinations carried out on samples subjected to thermal ageing to the nearest  $0,01 \% (m/m)$ . If the average of the duplicate determinations is  $< 0,01 \% (m/m)$ , report as " $< 0,01 \% (m/m)$ ". If a 5 g sample was used, report the result as "total sediment (5 g) by hot filtration". If filtration is not complete within the specified 25 min, report the results as "filtration time exceeds 25 min".

**9.3** Report the *accelerated total sediment* by hot filtration as the average of the duplicate determinations carried out on samples subjected to chemical ageing to the nearest  $0,01 \% (m/m)$ . If the average of the duplicate determinations is  $< 0,01 \% (m/m)$ , report as " $< 0,01 \% (m/m)$ ". If a 5 g sample was used, report the result as "total sediment (5 g) by hot filtration". If filtration is not complete within the specified 25 min, report the results as "filtration time exceeds 25 min".

When calculating the results of determinations of accelerated total sediment, take into account the hexadecane diluent by using a divisor of  $9,28m_1$  in Equation (1) instead of  $10m_1$ .

## 10 Precision

It was established in 1989, by the statistical examination of interlaboratory results, that neither of the ageing procedures described in this part of ISO 10307 affects the precision of ISO 10307-1.

## 11 Test report

The test report shall contain at least the following information:

- a) reference to this part of ISO 10307 (i.e. "ISO 10307-2:2009"), specifying the procedure (A or B) followed;
- b) the type and complete identification of the product tested;
- c) the result of the test after ageing, specifying whether potential or accelerated (see Clause 9);
- d) any deviation, by agreement or otherwise, from the procedures specified;
- e) the date of the test.



