**Petroleum products — Total sediment in
residual fuel oils —**

**Part 1:
Determination by hot filtration**

*Produits pétroliers — Insolubles existants dans les fuel-oils résiduels —
Partie 1: Détermination par filtration à chaud*



PDF disclaimer

This PDF file may contain embedded typefaces. In accordance with Adobe's licensing policy, this file may be printed or viewed but shall not be edited unless the typefaces which are embedded are licensed to and installed on the computer performing the editing. In downloading this file, parties accept therein the responsibility of not infringing Adobe's licensing policy. The ISO Central Secretariat accepts no liability in this area.

Adobe is a trademark of Adobe Systems Incorporated.

Details of the software products used to create this PDF file can be found in the General Info relative to the file; the PDF-creation parameters were optimized for printing. Every care has been taken to ensure that the file is suitable for use by ISO member bodies. In the unlikely event that a problem relating to it is found, please inform the Central Secretariat at the address given below.



COPYRIGHT PROTECTED DOCUMENT

© ISO 2009

All rights reserved. Unless otherwise specified, no part of this publication may be reproduced or utilized in any form or by any means, electronic or mechanical, including photocopying and microfilm, without permission in writing from either ISO at the address below or ISO's member body in the country of the requester.

ISO copyright office
Case postale 56 • CH-1211 Geneva 20
Tel. + 41 22 749 01 11
Fax + 41 22 749 09 47
E-mail copyright@iso.org
Web www.iso.org

Published in Switzerland

Foreword

ISO (the International Organization for Standardization) is a worldwide federation of national standards bodies (ISO member bodies). The work of preparing International Standards is normally carried out through ISO technical committees. Each member body interested in a subject for which a technical committee has been established has the right to be represented on that committee. International organizations, governmental and non-governmental, in liaison with ISO, also take part in the work. ISO collaborates closely with the International Electrotechnical Commission (IEC) on all matters of electrotechnical standardization.

International Standards are drafted in accordance with the rules given in the ISO/IEC Directives, Part 2.

The main task of technical committees is to prepare International Standards. Draft International Standards adopted by the technical committees are circulated to the member bodies for voting. Publication as an International Standard requires approval by at least 75 % of the member bodies casting a vote.

Attention is drawn to the possibility that some of the elements of this document may be the subject of patent rights. ISO shall not be held responsible for identifying any or all such patent rights.

ISO 10307-1 was prepared by Technical Committee ISO/TC 28, *Petroleum products and lubricants*.

This second edition cancels and replaces the first edition (ISO 10307-1:1993), which has been technically revised. It also incorporates the Technical Corrigendum ISO 10307-1:1993/Cor.1:1997.

ISO 10307 consists of the following parts, under the general title *Petroleum products — Total sediment in residual fuel oils*:

- *Part 1: Determination by hot filtration*
- *Part 2: Determination using standard procedures for ageing*

Petroleum products — Total sediment in residual fuel oils —

Part 1: Determination by hot filtration

WARNING — The use of this part of ISO 10307 could involve hazardous materials, operations and equipment. The document does not purport to address all of the safety problems associated with its use. It is the responsibility of the user of this part of ISO 10307 to establish appropriate safety and health practices, and determine the applicability of regulatory limitations prior to use.

1 Scope

This part of ISO 10307 specifies a method for the determination of total sediment in residual fuel oils having a maximum viscosity of $55 \text{ mm}^2/\text{s}$ at $100 \text{ }^\circ\text{C}$, and for blends of distillate fuels containing residual components. The maximum total sediment covered by the precision evaluations of this method is $0,50 \%$ (m/m) for residual fuels and $0,40 \%$ (m/m) for distillate fuels containing residual components. Some fuels could exceed the maximum filtration time specified in this method due to factors other than the presence of significant quantities of insoluble organic or inorganic material.

For the determination of sediment insoluble in toluene, see ISO 3735¹⁾.

NOTE 1 The method can also be used for the assessment of total sediment after regimes of fuel pre-treatment designed to accelerate the ageing process (see ISO 10307-2).

NOTE 2 Significant amounts of sediment in a residual fuel oil can cause fouling of facilities for handling and present problems in burner mechanisms. Sediment can accumulate in storage tanks, on filter screens or on burner parts, resulting in obstruction to flow of oil from the tank to the burner.

NOTE 3 For the purposes of this International Standard, the terms “% (m/m)” and “% (V/V)” are used to represent mass and volume fractions of a material, respectively. These expressions are deprecated under the International System and according to ISO 31-0, *Quantities and units — Part 0: General principles*, which specifies that mass and volume fractions be expressed as “mass fraction of xx %” (symbol ω) and “volume fraction of xx %” (symbol φ).

2 Normative references

The following referenced documents are indispensable for the application of this document. For dated references, only the edition cited applies. For undated references, the latest edition of the referenced document (including any amendments) applies.

ISO 3170:2004, *Petroleum liquids — Manual sampling*

ISO 3171:1988, *Petroleum liquids — Automatic pipeline sampling*

ISO 6353-2:1983, *Reagents for chemical analysis — Part 2: Specifications — First series*

ISO 6353-3:1987, *Reagents for chemical analysis — Part 3: Specifications — Second series*

1) ISO 3735, *Crude petroleum and fuel oils — Determination of sediment — Extraction method*.

3 Terms and definitions

For the purposes of this document, the following terms and definitions apply.

3.1

total sediment

sum of insoluble organic and inorganic material, separated from the bulk of the sample by filtration through a specified filter, and also insoluble in a predominantly paraffinic solvent

4 Principle

An aliquot of the oil sample is filtered through the prescribed apparatus (Clause 6) at 100 °C, and after solvent washing and drying the total sediment on the filter is weighed. The test is carried out in duplicate.

5 Materials

During the analysis, unless otherwise stated, use only reagents as specified in ISO 6353-2 and ISO 6353-3, if listed there. If not listed, then use reagents of a recognized analytical grade.

5.1 Heptane, $\text{CH}_3(\text{CH}_2)_5\text{CH}_3$.

WARNING — Heptane is a toxic volatile hydrocarbon, and shall only be used with adequate ventilation. Avoid inhalation of vapour or mist and prolonged skin contact.

5.2 Toluene, $\text{C}_6\text{H}_5\text{CH}_3$.

WARNING — Toluene is a toxic, volatile hydrocarbon which is absorbed by inhaling the vapour or through skin contact with the liquid. Use only in adequate ventilation and avoid skin contact.

5.3 Wash solvent, consisting of 85 % (V/V) heptane (5.1) and 15 % (V/V) toluene (5.2).

6 Apparatus

6.1 Filtration apparatus, an example of which is shown in Figure 1 and the arrangement of which is shown in Figure 2. Its construction is with steam coils attached, suitably supported, above a vacuum flask appropriately protected against the effects of implosion.

NOTE Other apparatus configurations have been shown to be satisfactory, provided that the dimensional requirements and heating-medium capacity are strictly adhered to.

6.2 Temperature measuring device, capable of measuring the temperature in the range from 95 °C to 105 °C with an accuracy of 0,5 °C.

6.3 Oven, capable of maintaining a temperature of 110 °C ± 1 °C and evaporating the solvent without risk of fire or explosion.

6.4 Stirring rod, glass or PTFE (polytetrafluoroethylene), approximately 150 mm in length and 3 mm in diameter.

6.5 Glass beaker, 30 ml capacity, either squat form with lip or conical.

6.6 Small dishes, such as watch glasses or Petri dishes.

6.7 Magnetic stirrer/hotplate, or other suitable heating device, capable of being controlled by a surface-temperature-measuring device (6.13), and polytetrafluoroethylene (PTFE)-coated stirring bars, length 25 mm.

6.8 Steam generator, to provide a source of steam at 100 °C ± 1 °C. Alternative heating media to steam are acceptable where steam is either not available or not available at the specified temperature.

6.9 Vacuum source, capable of providing the specified absolute pressure of $40 \text{ kPa} \pm 2 \text{ kPa}$ (61,3 kPa vacuum).

6.10 Vacuum gauge, capable of recording the absolute pressure or vacuum as specified in 6.9.

6.11 Glass-fibre filters, nominal porosity 0,001 6 mm, diameter 47 mm.

EXAMPLE Whatman GF/A.²⁾

6.12 High-speed mixer, of any convenient type with a minimum speed of 400 r/min.

6.13 Surface-temperature-measuring device, capable of measuring the temperature up to $200 \text{ }^\circ\text{C}$.

6.14 Cooling vessel, for cooling the filters before weighing while keeping them protected from contamination from the atmosphere. A desiccator-type vessel without drying agent is found suitable.

6.15 Graduated syringe or wash bottle, minimum capacity 25 ml, graduated at 0,5 ml intervals.

6.16 Forceps, spade-ended.

6.17 General-purpose temperature-measuring device, capable of measuring the temperature in the range from $0 \text{ }^\circ\text{C}$ to $100 \text{ }^\circ\text{C}$ with an accuracy of $0,5 \text{ }^\circ\text{C}$.

7 Sampling

Unless otherwise specified, samples shall be taken in accordance with ISO 3170 and ISO 3171.

8 Sample preparation

Mix the whole sample thoroughly using a high-speed mixer (6.12), if practicable, for 30 s. A sample taken on a glass or PTFE rod (6.4) dipped to the bottom of the container shall show a homogeneous appearance. For fuels with a high wax content (high pour point) or of very high viscosity, heat the sample before stirring. The temperature, as measured with the general-purpose temperature-measuring device (6.17), shall be either $15 \text{ }^\circ\text{C}$ to $18 \text{ }^\circ\text{C}$ above the pour point for low-viscosity fuels, or at a temperature sufficient to reduce the viscosity to between $150 \text{ mm}^2/\text{s}$ and $250 \text{ mm}^2/\text{s}$ for high-viscosity fuels. The temperature shall not exceed $80 \text{ }^\circ\text{C}$ during this preparation stage.

9 Filter preparation

For each test, dry two filters (6.11) for 20 min in the oven (6.3) at $110 \text{ }^\circ\text{C}$. Allow to cool in the cooling vessel (6.14) to room temperature for 20 min. Weigh each filter to the nearest 0,000 1 g.

NOTE 1 For convenience, the filters can be placed on numbered small dishes (6.6) during drying and cooling.

NOTE 2 It has been shown that the same level of results is achieved by the use of a fine wire mesh support screen (see Figure 1) in combination with a third, disposable filter. This third filter can be placed below the two test filters on the support screen and the same pre-drying regime followed as for the test filters, but without weighing the third filter before placement, discarding it when filtration is complete.

The glass-fibre filters are fragile, and need to be handled with care. Before use, check each against a background light for consistency and the possible presence of small defects (holes).

²⁾ Whatman[®] GF/A is an example of a suitable product available commercially. This information is given for the convenience of users of this part of ISO 10307 and does not constitute an endorsement by ISO of this product.

Dimensions in millimetres

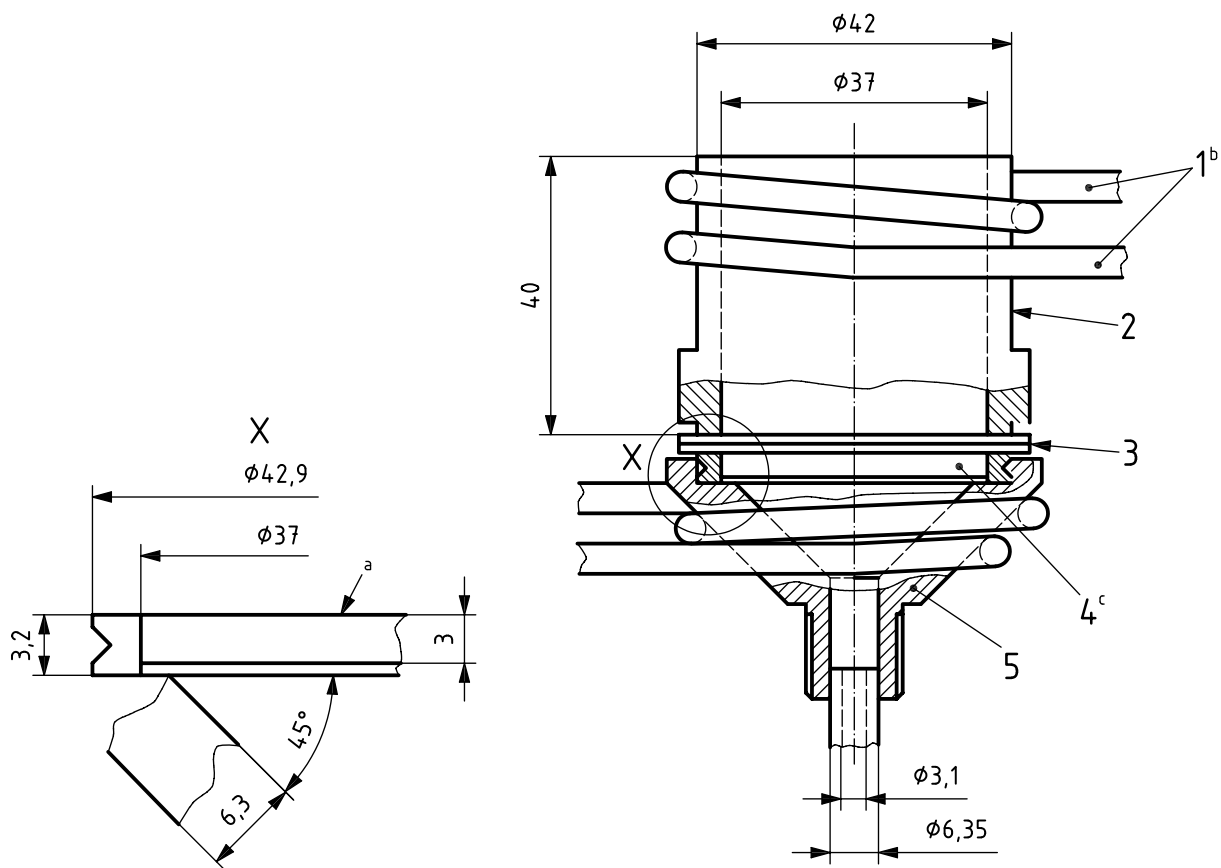

Key

- 1 heating/cooling coils (copper)
- 2 cup (brass)
- 3 filters
- 4 sintered disc or fine wire mesh
- 5 funnel, brass

^a Smooth face.

^b Diameter, \varnothing : exterior 4,8 mm; interior 2,9 mm.

^c See Clause 9, Note 2.

Figure 1 — Detail of filtration cell

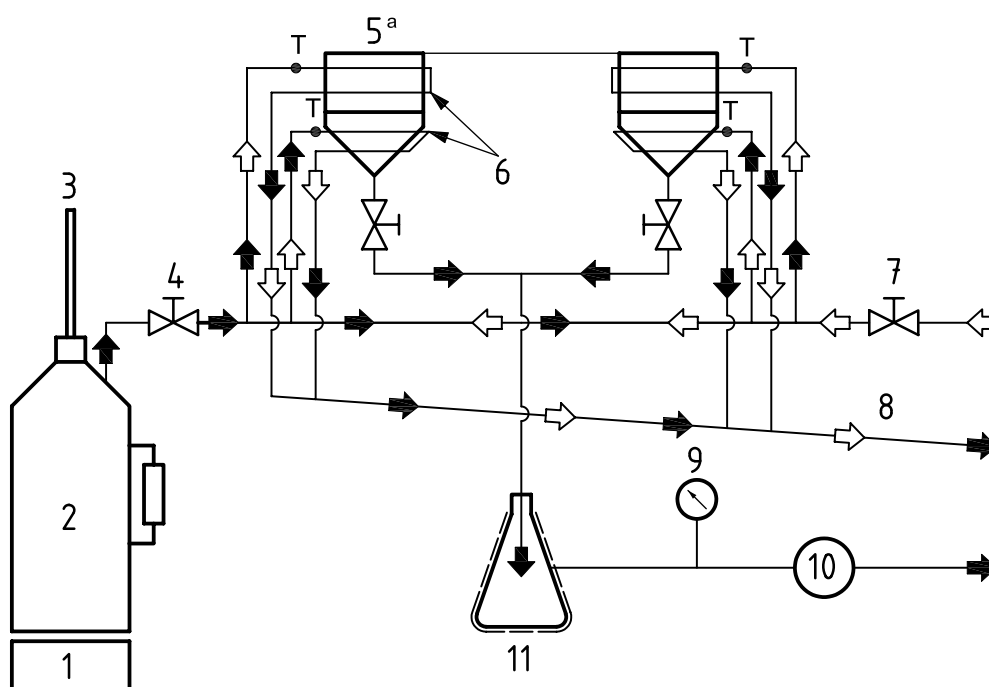
**Key**

- 1 heating device
- 2 steam generator
- 3 vent
- 4 steam
- 5 filtration cells
- 6 heating/cooling coils
- 7 cold water supply for cooling
- 8 drain line
- 9 vacuum gauge
- 10 vacuum pump
- 11 vacuum flask (protected against implosion)
- T temperature sensor

^a See Figure 1.

Figure 2 — Arrangement of filtration apparatus

10 Procedure

10.1 General

The determination shall be carried out in duplicate.

10.2 Assembly of apparatus

Before use, check that the filter support screen is clean, and if necessary clean it by boiling in a high-boiling aromatic solvent such as toluene (5.2). Renew the filter support screen if more than 2 % of the sinter area (i.e. a significant number of pores visible to the naked eye) is blocked by a particulate content after such cleaning.

The filtration unit (6.1) shall be clean and dry before assembly. Stack the two previously dried and weighed filters on top of the sinter support with the mesh imprint side down using forceps (6.16). Apply slight vacuum to

aid the centralization of the filters and place the top portion of the filtration apparatus carefully on the filters before clamping. Shut off the vacuum suction and press steam, or the alternative heating medium (see 6.8), at $100\text{ }^{\circ}\text{C} \pm 1\text{ }^{\circ}\text{C}$ through the unit for 10 min prior to addition of the test portion and throughout the addition and filtration stages.

10.3 Addition of test portion

Pour into a 30 ml beaker (6.5) with stirring bar approximately 11 g of the residual fuel sample or approximately 10,5 g of the blended distillate fuel sample prepared as in Clause 8, and weigh to the nearest 0,01 g (see Note 1 below). Connect the vacuum source (6.9) and apply vacuum to an absolute pressure of $40\text{ kPa} \pm 2\text{ kPa}$ ($61,3\text{ kPa}$ vacuum). Transfer the contents of the beaker, unheated for blended distillate fuel or at $100\text{ }^{\circ}\text{C} \pm 2\text{ }^{\circ}\text{C}$ for residual fuel (see Note 2 below) to the centre of the filter, taking care that none of the test portion touches the walls of the filtration cell during transfer. Residual-fuel test portions which overheat to above $105\text{ }^{\circ}\text{C}$ shall be discarded, and not re-used.

NOTE 1 When testing residual fuels, it can be expedient to weigh the beaker plus stirring bar before and after transfer, to avoid errors incurred by attempting to obtain a net mass. Any convenient means of heating the fuel sample to $100\text{ }^{\circ}\text{C} \pm 2\text{ }^{\circ}\text{C}$ can be used, such as hot plate, water or oil bath, or an oven when equipped with a suitable stirrer.

NOTE 2 (Local) overheating of the sample should be avoided when placed on a hotplate. Overheating can cause sample decomposition processes. Proper sample temperature control is therefore important. Placing the beaker in a metal block, which is placed on the magnetic stirrer/hotplate, is found suitable.

Re-weigh the beaker to the nearest 0,01 g. The quantity transferred shall be $10\text{ g} \pm 0,5\text{ g}$.

For samples of high viscosity and/or high sediment level, filtration will be aided by small-stage or even dropwise addition. It is expedient to use the maximum filter area available, but care shall be taken to avoid unfiltered oil coming into contact with the walls of the filtration cell. For samples of low filtration rate, the pressure of $40\text{ kPa} \pm 2\text{ kPa}$ shall be maintained for 25 min. If filtration is not complete in 25 min, discontinue the test and repeat the procedure using a $5\text{ g} \pm 0,3\text{ g}$ test portion. If the second filtration is still not complete in 25 min, report the result as "filtration time exceeds 25 min".

10.4 Filter washing

When the filtration is complete, and the upper filter appears dry, continue the steam and vacuum for a further 5 min. Discontinue the steam supply and cool the apparatus by passing tap water through the coils. Wash the upper filter carefully with two portions of $25\text{ ml} \pm 1\text{ ml}$ of wash solvent (5.3) dispensed from a graduated syringe or wash bottle with a fine nozzle (6.15), taking care to remove any adhered sample from the wall of the upper part of the apparatus. If the test portion filters very rapidly, release the vacuum before the addition of the first portion of wash solvent, to ensure complete coverage of the filter area by solvent. Then gently reapply the vacuum for the subsequent operations.

Carefully remove the top portion of the filtration unit and wash the rim of the filter area with a further $10\text{ ml} \pm 0,5\text{ ml}$ of wash solvent in a similar manner. Finally, wash the whole of the filter area with $10\text{ ml} \pm 0,5\text{ ml}$ of heptane (5.1).

10.5 Apparatus disassembly

When the upper filter appears dry, discontinue the vacuum. Using forceps, remove each filter separately and transfer them to the oven at $110\text{ }^{\circ}\text{C}$. Dry for 20 min. Allow to cool in the cooling vessel (6.14) to room temperature for 20 min. Weigh each filter to the nearest 0,000 1 g.

NOTE For convenience, the filters can be placed on numbered small dishes (6.6) during drying and cooling.

11 Expression of results

Calculate the mass percentage of total sediment for each test specimen using Equation (1):

$$S = \frac{(m_5 - m_4) - (m_3 - m_2)}{10m_1} \quad (1)$$

where

- S is the total sediment, expressed as percentage by mass;
- m_1 is the mass of the test portion, expressed in grams;
- m_2 is the mass of the lower filter before filtration, expressed in milligrams;
- m_3 is the mass of the lower filter after filtration, expressed in milligrams;
- m_4 is the mass of the upper filter before filtration, expressed in milligrams;
- m_5 is the mass of the upper filter after filtration, expressed in milligrams.

For each test specimen with a calculated total sediment concentration $> 0,005 \% (m/m)$ as determined by Equation (1), record the mass percentage of total sediment to the nearest $0,01 \% (m/m)$.

For each test specimen with a total sediment concentration $\leq 0,005 \% (m/m)$, record the result as $0,00 \% (m/m)$.

Report the total sediment by hot filtration as the average of the duplicate determinations to the nearest $0,01 \% (m/m)$. If the average of the duplicate determinations is $< 0,01 \% (m/m)$, report as " $< 0,01 \% (m/m)$ ". If a 5 g sample was used, report the result as "total sediment (5 g) by hot filtration". If filtration is not complete within the specified 25 min, report the results as "filtration time exceeds 25 min".

12 Precision

12.1 General

The precision of this test method as determined by the statistical examination of inter-laboratory test results is as follows. The results ranged from $0,01 \% (m/m)$ to $0,40 \% (m/m)$ for distillate fuel oils containing residual components and from $0,01 \% (m/m)$ to $0,50 \% (m/m)$ for residual fuel oils. These precision values have been obtained by statistical examination of the results of inter-laboratory tests on matrices of samples tested between 1986 and 1989, and were first published in 1990. The raw data generated from 1986 to 1989 have been subjected to a new statistical analysis using ISO 4259³⁾, and the new precision values for residual fuels were published in 1997.

12.2 Repeatability, r

The difference between successive test results, expressed as the average of duplicate determinations, obtained by the same operator with the same apparatus under constant operating conditions on identical test material would, in the long run, in the normal and correct operation of the test method, exceed the values below in only one case in twenty. Calculate the repeatability, r , for residual fuels using Equation (2) and for distillate fuels containing residual components using Equation (3):

$$r = 0,089\sqrt{x} \quad (2)$$

3) ISO 4259, *Petroleum products — Determination and application of precision data in relation to methods of test*

$$r = 0,048\sqrt{x} \quad (3)$$

where x is the average of the test results, expressed as a percentage by mass.

12.3 Reproducibility, R

The difference between two test results, expressed as the average of duplicate determinations independently obtained by different operators operating in different laboratories on nominally identical test material would, in the long run, in the normal and correct operation of the test method, exceed the values below in only one case in twenty. Calculate the reproducibility, R , for residual fuels using Equation (4) and for distillate fuels containing residual components using Equation (5):

$$R = 0,294\sqrt{x} \quad (4)$$

$$R = 0,174\sqrt{x} \quad (5)$$

where x is the average of the test results, expressed as a percentage by mass.

13 Test report

The test report shall contain at least the following information:

- a) reference to this part of ISO 10307 (i.e. "ISO 10307-1:2009");
- b) the type and complete identification of the product tested;
- c) the result of the test (see Clause 11);
- d) any deviation, by agreement or otherwise, from the procedure specified;
- e) the date of the test.

