

---

---

**Industrial automation systems and  
integration — Product data representation  
and exchange —**

Part 506:  
**Application interpreted construct:  
Drafting elements**

*Systèmes d'automatisation industrielle et intégration — Représentation et  
échange de données de produits —*

*Partie 506: Construction interprétée d'application: Éléments de traçage*



Reference number  
ISO 10303-506:2000(E)

© ISO 2000

**PDF disclaimer**

This PDF file may contain embedded typefaces. In accordance with Adobe's licensing policy, this file may be printed or viewed but shall not be edited unless the typefaces which are embedded are licensed to and installed on the computer performing the editing. In downloading this file, parties accept therein the responsibility of not infringing Adobe's licensing policy. The ISO Central Secretariat accepts no liability in this area.

Adobe is a trademark of Adobe Systems Incorporated.

Details of the software products used to create this PDF file can be found in the General Info relative to the file; the PDF-creation parameters were optimized for printing. Every care has been taken to ensure that the file is suitable for use by ISO member bodies. In the unlikely event that a problem relating to it is found, please inform the Central Secretariat at the address given below.

© ISO 2000

All rights reserved. Unless otherwise specified, no part of this publication may be reproduced or utilized in any form or by any means, electronic or mechanical, including photocopying and microfilm, without permission in writing from either ISO at the address below or ISO's member body in the country of the requester.

ISO copyright office  
Case postale 56 • CH-1211 Geneva 20  
Tel. + 41 22 749 01 11  
Fax + 41 22 734 10 79  
E-mail [copyright@iso.ch](mailto:copyright@iso.ch)  
Web [www.iso.ch](http://www.iso.ch)

Printed in Switzerland

<b>Contents</b>	<b>Page</b>
1 Scope .....	1
2 Normative references .....	2
3 Terms, definitions and abbreviations .....	3
3.1 Terms defined in ISO 5459 .....	3
3.2 Terms defined in ISO 10209-1 .....	3
3.3 Terms defined in ISO 10303-1 .....	3
3.4 Terms defined in ISO 10303-46 .....	3
3.5 Terms defined in ISO 10303-101 .....	4
3.6 Terms defined in ISO 10303-202 .....	4
3.7 Other definitions .....	4
3.8 Abbreviations .....	4
4 EXPRESS short listing .....	5
4.1 aic_draughting_elements entity definitions .....	5
Annex A (normative) Short names of entities .....	20
Annex B (normative) Information object registration .....	21
B.1 Document identification .....	21
B.2 Schema identification .....	21
Annex C (informative) EXPRESS-G diagrams .....	22
Annex D (informative) Computer interpretable listings .....	27
Index .....	28
<b>Figures</b>	
Figure 1 - Angular and radius dimensions .....	6
Figure 2 - Curve dimension .....	6
Figure 3 - Draughting callouts .....	8
Figure 4 - Diameter dimension .....	9
Figure 5 - Structured dimension callout .....	10
Figure 6 - Parallel dimension pair .....	12
Figure 7 - Chain dimension pair .....	12
Figure 8 - Leader directed dimension .....	15
Figure 9 - Ordinate dimension .....	16
Figure C.1 - AIC expanded listing diagram in EXPRESS-G: 1 of 4 .....	23
Figure C.2 - AIC expanded listing diagram in EXPRESS-G: 2 of 4 .....	24
Figure C.3 - AIC expanded listing diagram in EXPRESS-G: 3 of 4 .....	25
Figure C.4 - AIC expanded listing diagram in EXPRESS-G: 4 of 4 .....	26
<b>Tables</b>	
Table A.1 - Short names of entities .....	20

## Foreword

ISO (the International Organization for Standardization) is a worldwide federation of national standards bodies (ISO member bodies). The work of preparing International Standards is normally carried out through ISO technical committees. Each member body interested in a subject for which a technical committee has been established has the right to be represented on that committee. International organizations, governmental and non-governmental, in liaison with ISO, also take part in the work. ISO collaborates closely with the International Electrotechnical Commission (IEC) on all matters of electrotechnical standardization.

International Standards are drafted in accordance with the rules given in the ISO/IEC Directives, Part 3.

Draft International Standards adopted by the technical committees are circulated to the member bodies for voting. Publication as an International Standard requires approval by at least 75 % of the member bodies casting a vote.

Attention is drawn to the possibility that some of the elements of this International Standard may be the subject of patent rights. ISO shall not be held responsible for identifying any or all such patent rights.

International Standard ISO 10303-506 was prepared by Technical Committee ISO/TC 184, *Industrial automation systems and integration*, Subcommittee SC4, *Industrial data*.

This International Standard is organized as a series of parts, each published separately. The parts of ISO 10303 fall into one of the following series: description methods, integrated resources, application protocols, abstract test suites, implementation methods, and conformance testing. The series are described in ISO 10303-1.

A complete list of parts of ISO 10303 is available from the internet:

<http://www.nist.gov/sc4/editing/step/titles/>

Annexes A and B form a normative part of this part of ISO 10303. Annexes C and D are for information only.

## Introduction

ISO 10303 is an International Standard for the computer-interpretable representation and exchange of product data. The objective is to provide a neutral mechanism capable of describing product data throughout the life cycle of a product, independent from any particular system. The nature of this description makes it suitable not only for neutral file exchange, but also as a basis for implementing and sharing product databases and archiving.

This International Standard is organized as a series of parts, each published separately. The parts of ISO 10303 fall into one of the following series: description methods, integrated resources, application interpreted constructs, application protocols, abstract test suites, implementation methods, and conformance testing. The series are described in ISO 10303-1. This part of ISO 10303 is a member of the application interpreted constructs series.

An application interpreted construct (AIC) provides a logical grouping of interpreted constructs that supports a specific functionality for the usage of product data across multiple application contexts. An interpreted construct is a common interpretation of the integrated resources that supports shared information requirements among application protocols.

This document specifies the application interpreted construct for the description of annotation that presents dimensions and draughting callouts on a drawing. This annotation, in the form of text and symbology, provides additional product data that may be needed to fully define the product or interpret the drawing.



---

# **Industrial automation systems and integration — Product data representation and exchange — Part 506: Application interpreted construct: Draughting elements**

## **1 Scope**

This part of ISO 10303 specifies the interpretation of the integrated resources to satisfy requirements for the definition of annotation that presents dimensions and draughting callouts within a draughting application.

The following are within the scope of this part of ISO 10303:

- the structures for representing single or composite dimensions;
- the structures for representing structured or unstructured dimensions;
- the structures for representing draughting callouts that may be directed by means of leaders, projection curves, or dimension curves.

The following is outside the scope of this part of ISO 10303:

- annotation that is not used in the presentation a dimension or draughting callout.

## 2 Normative references

The following normative documents contain provisions which, through reference in this text, constitute provisions of this International Standard. For dated references, subsequent amendments to, or revision of, any of these publications do not apply. However, parties to agreements based on this part of ISO 10303 are encouraged to investigate the possibility of applying the most recent editions of the normative documents indicated below. For undated references, the latest edition of the normative document referred to applies. Members of the ISO and IEC maintain registers of currently valid International Standards.

ISO 5459:1981, *Technical drawings — Geometric tolerancing — Datums and datum-systems for geometrical tolerances*.

ISO/IEC 8824-1:1995, *Information technology — Abstract syntax notation one (ASN.1): Specification of basic notation*.

ISO 10209-1:1992, *Technical product documentation — Vocabulary — Part 1: Terms relating to technical drawings: general and types of drawings*.

ISO 10303-1:1994, *Industrial automation systems and integration — Product data representation and exchange — Part 1: Overview and fundamental principles*.

ISO 10303-11:1994, *Industrial automation systems and integration — Product data representation and exchange — Part 11: Description methods: The EXPRESS language reference manual*.

ISO 10303-46:1994, *Industrial automation systems and integration — Product data representation and exchange — Part 46: Integrated generic resources: Visual presentation*.

ISO 10303-101:1994, *Industrial automation systems and integration — Product data representation and exchange — Part 101: Integrated application resources: Draughting*.

ISO 10303-202:1996, *Industrial automation systems and integration — Product data representation and exchange — Part 202: Application protocol: Associative draughting*.



### 3 Terms, definitions and abbreviations

#### 3.1 Terms defined in ISO 5459

For the purposes of this part of ISO 10303, the following terms defined in ISO 5459 apply:

- datum.

#### 3.2 Terms defined in ISO 10209-1

For the purposes of this part of ISO 10303, the following terms defined in ISO 10209-1 apply:

- drawing.

#### 3.3 Terms defined in ISO 10303-1

For the purposes of this part of ISO 10303, the following terms defined in ISO 10303-1 apply:

- application;
- application context;
- application protocol (AP);
- implementation method;
- integrated resource;
- interpretation;
- product data.

#### 3.4 Terms defined in ISO 10303-46

For the purposes of this part of ISO 10303, the following terms defined in ISO 10303-46 apply:

- annotation;
- presentation.

### 3.5 Terms defined in ISO 10303-101

For the purposes of this part of ISO 10303, the following terms defined in ISO 10303-101 apply:

- callout;
- draughting.

### 3.6 Terms defined in ISO 10303-202

#### 3.6.1

##### **application interpreted construct**

##### **AIC**

a logical grouping of interpreted constructs that supports a specific function for the usage of product data across multiple application contexts

[ISO 10303-202:1996]

### 3.7 Other definitions

For the purposes of this part of ISO 10303, the following definition applies.

#### 3.7.1

##### **dimension value**

a representation of the numerical value of a dimension that describes the magnitude of the dimension

### 3.8 Abbreviations

For the purposes of this part of ISO 10303, the following abbreviations apply.

AIC application interpreted construct

AP application protocol

## 4 EXPRESS short listing

This clause specifies the EXPRESS schema that uses elements from the integrated resources and contains the types, entity specializations, and functions that are specific to this part of ISO 10303.

NOTE 1 - There may be subtypes and items of select lists that appear in the integrated resources that are not imported into the AIC. Constructs are eliminated from the subtype tree or select list through the use of the implicit interface rules of ISO 10303-11. References to eliminated constructs are outside the scope of the AIC. In some cases, all items of the select list are eliminated. Because AICs are intended to be implemented in the context of an application protocol, the items of the select list will be defined by the scope of the application protocol.

### EXPRESS Specification

```

*)
SCHEMA aic_draughting_elements;

USE FROM draughting_element_schema -- ISO 10303-101
  (dimension_curve,
   dimension_curve_directed_callout,
   dimension_curve_terminator,
   draughting_callout,
   draughting_callout_relationship,
   leader_curve,
   leader_directed_callout,
   leader_terminator,
   projection_curve,
   projection_directed_callout);

USE FROM presentation_definition_schema -- ISO 10303-46
  (annotation_text_occurrence);
(*)

```

NOTE 2 - The schemas referenced above can be found in the following parts of ISO 10303:

draughting_element_schema	ISO 10303-101
presentation_definition_schema	ISO 10303-46

## 4.1 aic\_draughting\_elements entity definitions

### 4.1.1 angular\_dimension

An **angular\_dimension** is a **draughting\_callout** directed by a dimension curve that presents a value of angular distance measure.

NOTE - Figure 1 illustrates three angular dimensions used to depict information about angular distance measures. The figure also illustrates a radius dimension.

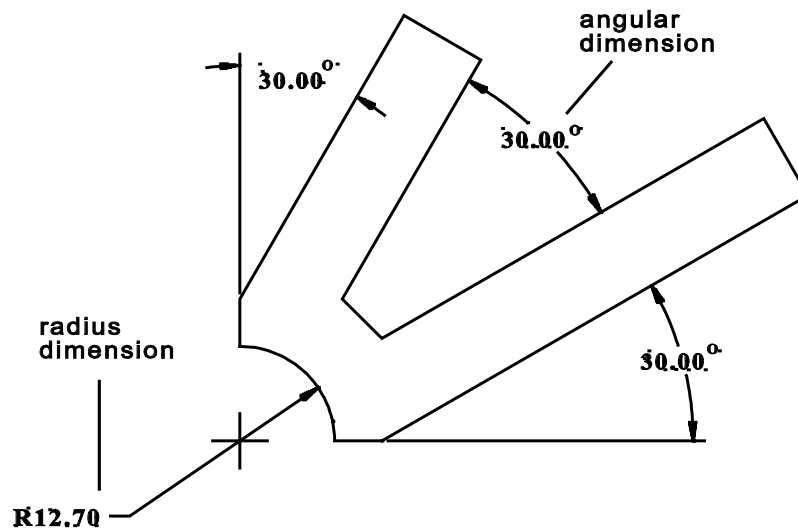

**Figure 1 - Angular and radius dimensions**

EXPRESS specification:

```

*)
ENTITY angular_dimension
  SUBTYPE of (dimension_curve_directed_callout);
END_ENTITY;
(*
    
```

### 4.1.2 curve\_dimension

A **curve\_dimension** is a **draughting\_callout** directed by a dimension curve that presents a value of distance between two elements, measured along a curved path, or the length of a curved element.

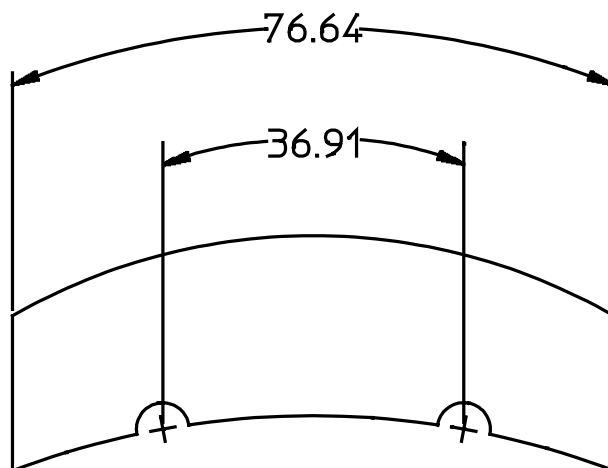

**Figure 2 - Curve dimension**

NOTE - Figure 2 illustrates two curve dimensions. The dimension with a value of “36.91” depicts the distance between two elements along a path defined by a third element of geometry or annotation. The dimension with a value of “76.64” depicts the length of a curve, measured along the entire path of the curve.

EXPRESS specification:

```
*)
ENTITY curve_dimension
  SUBTYPE OF (dimension_curve_directed_callout);
END_ENTITY;
(*
```

### 4.1.3 datum\_feature\_callout

A **datum\_feature\_callout** is a **draughting\_callout** that presents a datum. It shall contain an alphanumeric designation to be used as identification of the datum.

NOTE - Figure 3 illustrates the dimensioning and annotation of specific features of a product. The top view illustrates the specification of Datums “E” and “F” and the specification of a diameter dimension with an associated geometrical tolerance. The middle view of the same figure illustrates a specification of Datum “D”.

EXPRESS specification:

```
*)
ENTITY datum_feature_callout
  SUBTYPE of (draughting_callout);
END_ENTITY;
(*
```

### 4.1.4 datum\_target\_callout

A **datum\_target\_callout** is a **draughting\_callout** that presents a datum target. It shall contain an alphanumeric designation and, where applicable, a specification of the diametrical size of the target area.

NOTE - The bottom view in Figure 3 illustrates three datum target points and their associated datum target symbols.

EXPRESS specification:

```
*)
ENTITY datum_target_callout
  SUBTYPE of (draughting_callout);
END_ENTITY;
(*
```

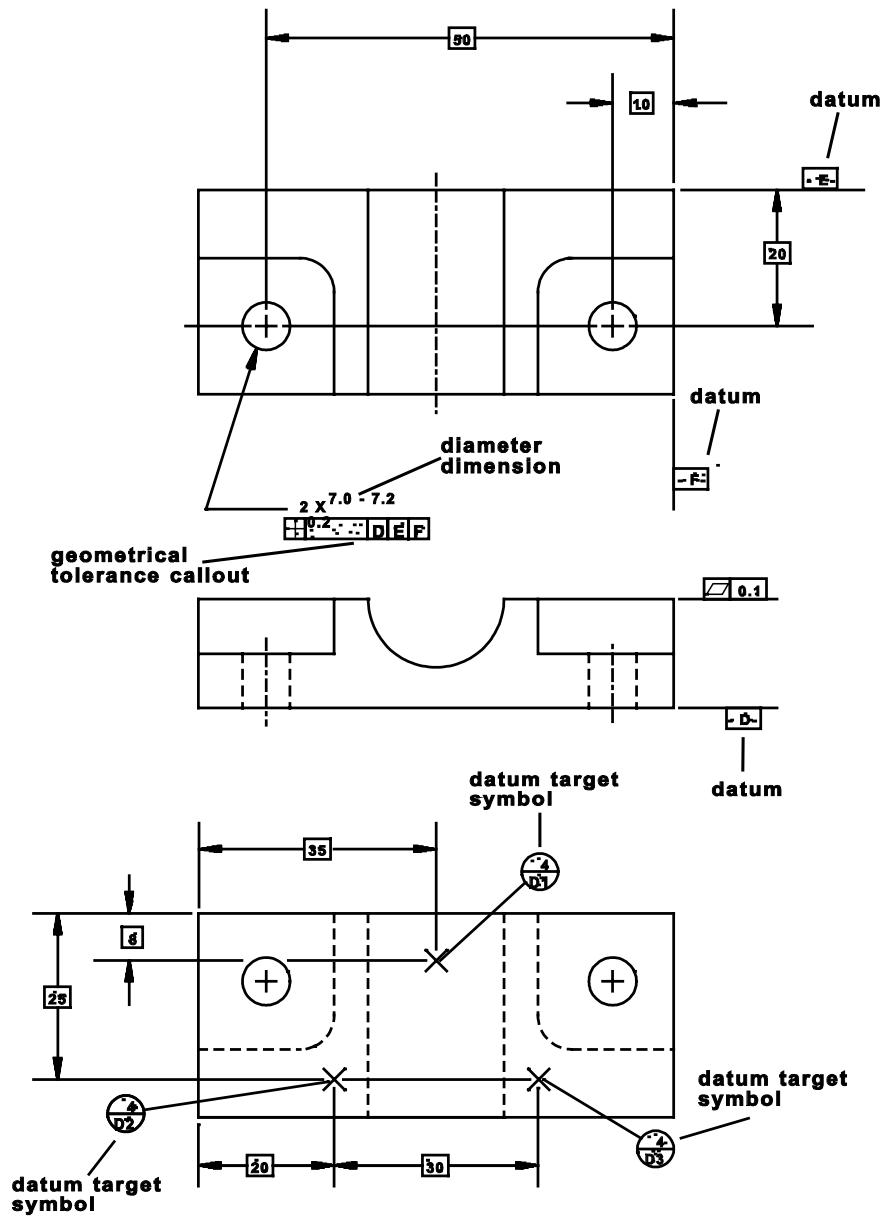
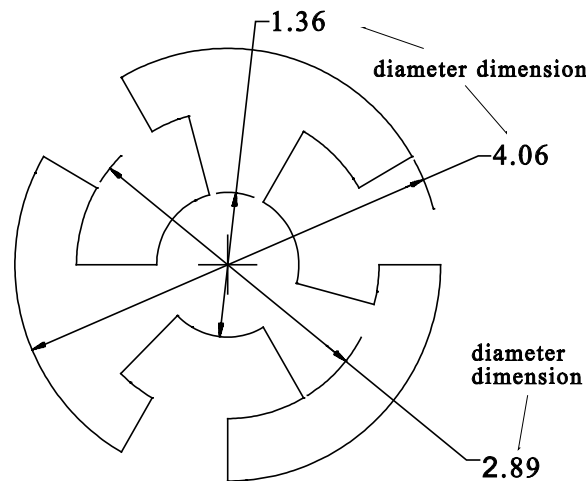

Figure 3 - Draughting callouts

### 4.1.5 diameter\_dimension

A **diameter\_dimension** is a **draughting\_callout** directed by a dimension curve that presents a value of the diametrical size of a circular element.

NOTE - Figure 4 illustrates three diameter dimensions. Projection lines can be used to clarify the extent of the dimension.



**Figure 4 - Diameter dimension**

EXPRESS specification:

```

*)
ENTITY diameter_dimension
  SUBTYPE OF (dimension_curve_directed_callout);
END_ENTITY;
(*

```

#### 4.1.6 dimension\_callout\_component\_relationship

A **dimension\_callout\_component\_relationship** is a **draughting\_callout\_relationship** that identifies the association between a **structured\_dimension\_callout** and a **draughting\_callout** that participates in its definition either as prefix information or suffix information. A dimension prefix specification is information used in interpreting the dimension or its applicability and is physically located before the dimension value as the dimension is read. A dimension suffix specification is physically located after the dimension value as the dimension is read and either contains information used in interpreting the dimension or its applicability or contains additional information that is used in conjunction with the dimension.

NOTE - Figure 5 illustrates a structured dimension callout with both prefix and suffix information.

EXPRESS specification:

```

*)
ENTITY dimension_callout_component_relationship
  SUBTYPE OF (draughting_callout_relationship);
WHERE
  WR1: SELF.name IN ['prefix', 'suffix'];
  WR2: 'AIC_DRAUGHTING_ELEMENTS.STRUCTURED_DIMENSION_CALLOUT'
      IN TYPEOF (SELF.relatng_draughting_callout);
  WR3: SIZEOF (TYPEOF (SELF.related_draughting_callout) *
    ['AIC_DRAUGHTING_ELEMENTS.LEADER_DIRECTED_CALLOUT',
     'AIC_DRAUGHTING_ELEMENTS.PROJECTION_DIRECTED_CALLOUT',
     'AIC_DRAUGHTING_ELEMENTS.DIMENSION_CURVE_DIRECTED_CALLOUT',
     'AIC_DRAUGHTING_ELEMENTS.STRUCTURED_DIMENSION_CALLOUT']) = 0;

```

```

WR4: SELF.related_draughting_callout.contents *
      SELF.relatng_draughting_callout.contents =
      SELF.related_draughting_callout.contents;
WR5: ((SELF.name = 'prefix') AND
      (SIZEOF (QUERY (ato <* QUERY (con <*
        SELF.related_draughting_callout.contents |
        ('AIC_DRAUGHTING_ELEMENTS.ANNOTATION_TEXT_OCCURRENCE'
        IN TYPEOF(con))) | NOT (ato.name = 'prefix text')
      )) = 0));
WR6: ((SELF.name = 'suffix') AND
      (SIZEOF (QUERY (ato <* QUERY (con <*
        SELF.related_draughting_callout.contents |
        ('AIC_DRAUGHTING_ELEMENTS.ANNOTATION_TEXT_OCCURRENCE'
        IN TYPEOF(con))) | NOT (ato.name = 'suffix text')
      )) = 0));
END_ENTITY;
(*

```

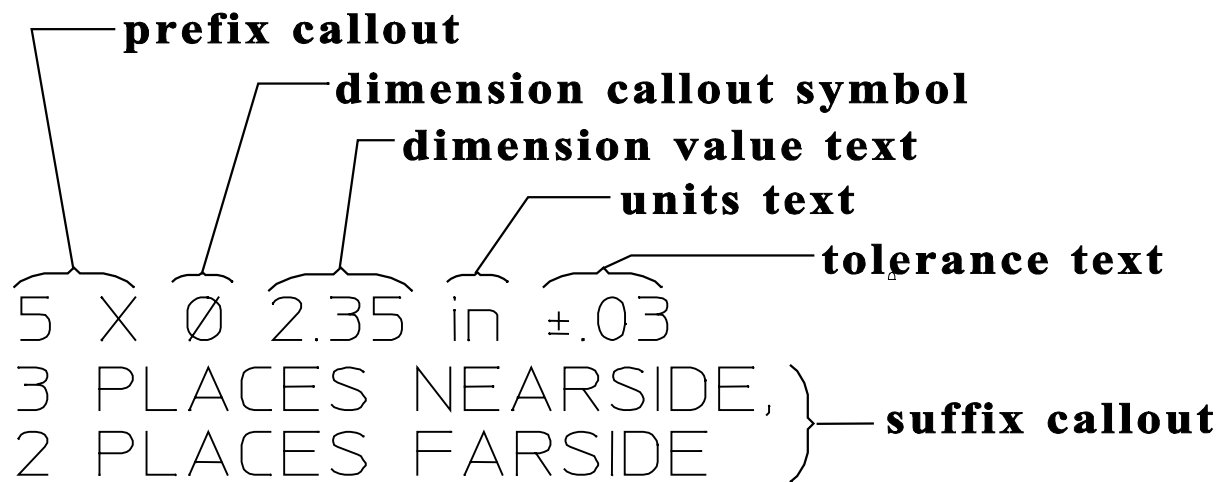

Figure 5 - Structured dimension callout

Attribute definitions:

**SELF\draughting\_callout\_relationship.relatng\_draughting\_callout**: the **structured\_dimension\_callout** with which another **draughting\_callout** is associated.

**SELF\draughting\_callout\_relationship.related\_draughting\_callout**: the **draughting\_callout** that takes part in the definition of a dimension callout.

Formal propositions:

**WR1**: The name of the **dimension\_callout\_component\_relationship** shall be either “prefix” or “suffix”.

**WR2**: The **relatng\_draughting\_callout** shall be a **structured\_dimension\_callout**.

**WR3**: The **related\_draughting\_callout** shall not be a **leader\_directed\_callout**, **projection\_directed\_callout**, **dimension\_curve\_directed\_callout**, or **structured\_dimension\_callout**.



**WR4:** Each element of the **draughting\_callout** shall also be an element of the **structured\_dimension\_callout**.

**WR5:** If the **name** of the **dimension\_callout\_component\_relationship** is “prefix”, all **annotation\_text\_occurrences** within the **related\_draughting\_callout** shall have a **name** of “prefix text”.

**WR6:** If the **name** of the **dimension\_callout\_component\_relationship** is “suffix”, all **annotation\_text\_occurrences** within the **related\_draughting\_callout** shall have a **name** of “suffix text”.

#### 4.1.7 dimension\_callout\_relationship

A **dimension\_callout\_relationship** is a **draughting\_callout\_relationship** that relates the presentation of a dimension to the presentation of the dimension callout either as the primary callout or as the secondary callout. A primary callout is a **draughting\_callout** that presents the dimension value in the primary unit of measure. A secondary callout is a **draughting\_callout** that presents the dimension value in another unit of measure.

##### EXPRESS specification:

```

*)
ENTITY dimension_callout_relationship
  SUBTYPE OF (draughting_callout_relationship);
WHERE
  WR1: SELF.name IN ['primary', 'secondary'];
  WR2: SIZEOF (TYPEOF (SELF.relater_draughting_callout) *
    ['AIC_DRAUGHTING_ELEMENTS.ANGULAR_DIMENSION',
    'AIC_DRAUGHTING_ELEMENTS.CURVE_DIMENSION',
    'AIC_DRAUGHTING_ELEMENTS.DIAMETER_DIMENSION',
    'AIC_DRAUGHTING_ELEMENTS.LEADER_DIRECTED_DIMENSION',
    'AIC_DRAUGHTING_ELEMENTS.LINEAR_DIMENSION',
    'AIC_DRAUGHTING_ELEMENTS.ORDINATE_DIMENSION',
    'AIC_DRAUGHTING_ELEMENTS.RADIUS_DIMENSION']) >= 1;
  WR3: SIZEOF (TYPEOF (SELF.related_draughting_callout) *
    ['AIC_DRAUGHTING_ELEMENTS.DIMENSION_CURVE_DIRECTED_CALLOUT',
    'AIC_DRAUGHTING_ELEMENTS.PROJECTION_DIRECTED_CALLOUT',
    'AIC_DRAUGHTING_ELEMENTS.LEADER_DIRECTED_CALLOUT']) = 0;
  WR4: SELF.related_draughting_callout.contents *
    SELF.relater_draughting_callout.contents =
    SELF.related_draughting_callout.contents;
END_ENTITY;
(*

```

##### Attribute definitions:

**SELF\draughting\_callout\_relationship.relater\_draughting\_callout:** the dimension with which a dimension callout is associated.

**SELF\draughting\_callout\_relationship.related\_draughting\_callout:** the dimension callout.

##### Formal propositions:

**WR1:** The **name** of the **dimension\_callout\_relationship** shall be either “primary” or “secondary”.

WR2: The dimension shall be one or more of **angular\_dimension**, **curve\_dimension**, **diameter\_dimension**, **leader\_directed\_dimension**, **linear\_dimension**, **ordinate\_dimension**, or **radius\_dimension**.

WR3: The dimension callout shall not be a **dimension\_curve\_directed\_callout**, **projection\_curve\_directed\_callout**, or **leader\_directed\_callout**.

WR4: Each element of the dimension callout shall also be an element of the dimension.

### 4.1.8 dimension\_pair

A **dimension\_pair** is a **draughting\_callout\_relationship** that identifies the relationship between dimensions that participate in a chained or parallel dimension sequence. A chained dimension sequence is a sequence of two or more dimensions in which the terminus of one dimension initializes the next dimension in the sequence. A parallel dimension sequence is a collection of two or more dimensions where all the dimensions are of the same type, their dimension lines are parallel to one another, the dimensions share a common origin or datum, or all three.

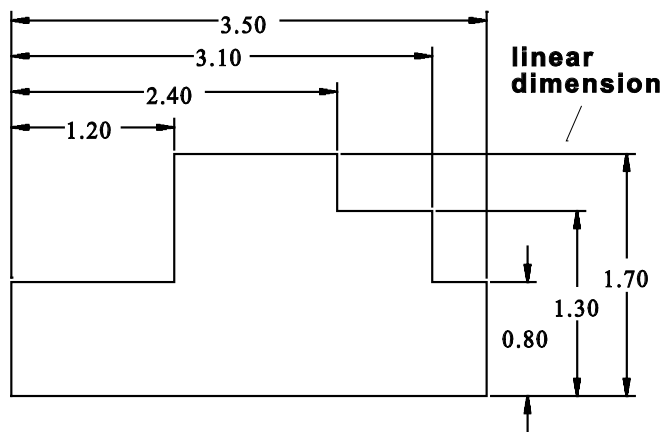

Figure 6 - Parallel dimension pair

NOTE - Figure 6 illustrates four horizontally-drawn linear dimensions in a series of parallel dimension pairs and three vertically-drawn linear dimensions in a series of parallel dimension pairs. Figure 7 illustrates three horizontally-drawn linear dimensions in a series of chained dimension pairs. In both figures, each set of two dimensions sharing a projection line is a dimension pair.

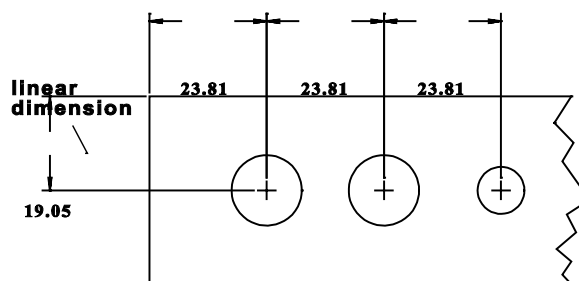

Figure 7 - Chain dimension pair

EXPRESS specification:

```

*)
ENTITY dimension_pair
  SUBTYPE OF (draughting_callout_relationship);
WHERE
  WR1: SELF.name IN ['chained', 'parallel'];
  WR2: SIZEOF (TYPEOF (SELF.relatng_draughting_callout) *
    ['AIC_DRAUGHTING_ELEMENTS.ANGULAR_DIMENSION',
     'AIC_DRAUGHTING_ELEMENTS.CURVE_DIMENSION',
     'AIC_DRAUGHTING_ELEMENTS.DIAMETER_DIMENSION',
     'AIC_DRAUGHTING_ELEMENTS.LINEAR_DIMENSION',
     'AIC_DRAUGHTING_ELEMENTS.ORDINATE_DIMENSION',
     'AIC_DRAUGHTING_ELEMENTS.RADIUS_DIMENSION'])=1;
  WR3: SIZEOF (TYPEOF (SELF.related_draughting_callout) *
    ['AIC_DRAUGHTING_ELEMENTS.ANGULAR_DIMENSION',
     'AIC_DRAUGHTING_ELEMENTS.CURVE_DIMENSION',
     'AIC_DRAUGHTING_ELEMENTS.DIAMETER_DIMENSION',
     'AIC_DRAUGHTING_ELEMENTS.LINEAR_DIMENSION',
     'AIC_DRAUGHTING_ELEMENTS.ORDINATE_DIMENSION',
     'AIC_DRAUGHTING_ELEMENTS.RADIUS_DIMENSION'])=1;
END_ENTITY;
(*

```

Attribute definitions:

**SELF\draughting\_callout\_relationship.relatng\_draughting\_callout:** the predecessor dimension.

**SELF\draughting\_callout\_relationship.related\_draughting\_callout:** the successor dimension.

Formal propositions:

**WR1:** The **name** of the **dimension\_pair** shall be either “chained” or “parallel”.

**WR2:** The predecessor dimension in the **dimension\_pair** shall be an **angular\_dimension**, **curve\_dimension**, **diameter\_dimension**, **linear\_dimension**, **ordinate\_dimension**, or **radius\_dimension**.

**WR3:** The successor dimension in the **dimension\_pair** shall be an **angular\_dimension**, **curve\_dimension**, **diameter\_dimension**, **linear\_dimension**, **ordinate\_dimension**, or **radius\_dimension**.

#### 4.1.9 draughting\_elements

A **draughting\_elements** is a **draughting\_callout** that specifies constraints on the grouping of annotation within the context of draughting. An application protocol that uses this AIC shall ensure that the **draughting\_callout** entity is instantiated as an **draughting\_elements** entity.

EXPRESS specification:

```

*)
ENTITY draughting_elements
  SUBTYPE OF (draughting_callout);
WHERE
  WR1: SIZEOF (QUERY (l_c <* QUERY (con <* SELF.contents |
    ('AIC_DRAUGHTING_ELEMENTS.LEADER_CURVE' IN TYPEOF(con))) |
    NOT (SIZEOF (QUERY (ldc <* USEDIN (l_c,
    'AIC_DRAUGHTING_ELEMENTS.' + 'DRAUGHTING_CALLOUT.CONTENTENTS') |
    ('AIC_DRAUGHTING_ELEMENTS.LEADER_DIRECTED_CALLOUT'
    IN TYPEOF (ldc)))) <= 1)))=0;
  WR2: NOT ('AIC_DRAUGHTING_ELEMENTS.DIMENSION_CURVE_DIRECTED_CALLOUT'
    IN TYPEOF(SELF)) OR
    (SIZEOF (QUERY (con <* SELF.contents |
    ('AIC_DRAUGHTING_ELEMENTS.PROJECTION_CURVE' IN
    TYPEOF (con)))) <= 2);
  WR3: SIZEOF (QUERY (rc <* USEDIN (SELF,
    'AIC_DRAUGHTING_ELEMENTS.DRAUGHTING_CALLOUT_' +
    'RELATIONSHIP.RELATING_DRAUGHTING_CALLOUT') |
    ('AIC_DRAUGHTING_ELEMENTS.' +
    'DIMENSION_CALLOUT_RELATIONSHIP' IN TYPEOF (rc)) AND
    (rc.name = 'primary') )) <= 1;
  WR4: SIZEOF (QUERY (rc <* USEDIN (SELF,
    'AIC_DRAUGHTING_ELEMENTS.DRAUGHTING_CALLOUT_' +
    'RELATIONSHIP.RELATING_DRAUGHTING_CALLOUT') |
    ('AIC_DRAUGHTING_ELEMENTS.' +
    'DIMENSION_CALLOUT_RELATIONSHIP' IN TYPEOF (rc)) AND
    (rc.name = 'secondary') )) <= 1;
  WR5: SIZEOF (QUERY (sec <* QUERY (rc <* USEDIN (SELF,
    'AIC_DRAUGHTING_ELEMENTS.DRAUGHTING_CALLOUT_' +
    'RELATIONSHIP.RELATING_DRAUGHTING_CALLOUT') |
    ('AIC_DRAUGHTING_ELEMENTS.' +
    'DIMENSION_CALLOUT_RELATIONSHIP' IN TYPEOF (rc)) AND
    (rc.name = 'secondary') ) |
    NOT (SIZEOF (QUERY (prim <* USEDIN (SELF,
    'AIC_DRAUGHTING_ELEMENTS.DRAUGHTING_CALLOUT_' +
    'RELATIONSHIP.RELATING_DRAUGHTING_CALLOUT') |
    ('AIC_DRAUGHTING_ELEMENTS.' +
    'DIMENSION_CALLOUT_RELATIONSHIP' IN TYPEOF (prim)) AND
    (prim.name = 'primary') )) = 1))) = 0;
END_ENTITY;
(*

```

Formal propositions:

**WR1:** Each **leader\_curve** that is in the contents of a **draughting\_callout** shall be used by at most one **leader\_directed\_callout**.

**WR2:** Each **dimension\_curve\_directed\_callout** shall contain at most two **projection\_curves** in the set of contents.

**WR3:** Each **draughting\_callout** shall be the specified **dimension** of at most one **dimension\_callout\_relationship** with a **name** of “primary”.

**WR4:** Each **draughting\_callout** shall be the specified **dimension** of at most one **dimension\_callout\_relationship** with a **name** of “secondary”.

**WR5:** Each **draughting\_callout** shall not participate in a secondary **dimension\_callout\_relationship** unless it also participates in a primary **dimension\_callout\_relationship**.

#### 4.1.10 geometrical\_tolerance\_callout

A **geometrical\_tolerance\_callout** is a **draughting\_callout** that presents a geometrical tolerance.

NOTE - The top view in Figure 3 illustrates the specification of a diameter dimension with an associated geometrical tolerance. The middle view illustrates a geometrical tolerance related by a projection line. Computer-interpretable geometric tolerances are outside the scope of this application interpreted construct.

EXPRESS specification:

```

*)
ENTITY geometrical_tolerance_callout
  SUBTYPE OF (draughting_callout);
END_ENTITY;
(*

```

#### 4.1.11 leader\_directed\_dimension

A **leader\_directed\_dimension** is a **draughting\_callout** directed by a leader curve that presents some dimension value.

NOTE - Figure 8 illustrates a leader directed dimension used to depict information about the holes in the product. Linear dimensions are used to show the placement of the holes.

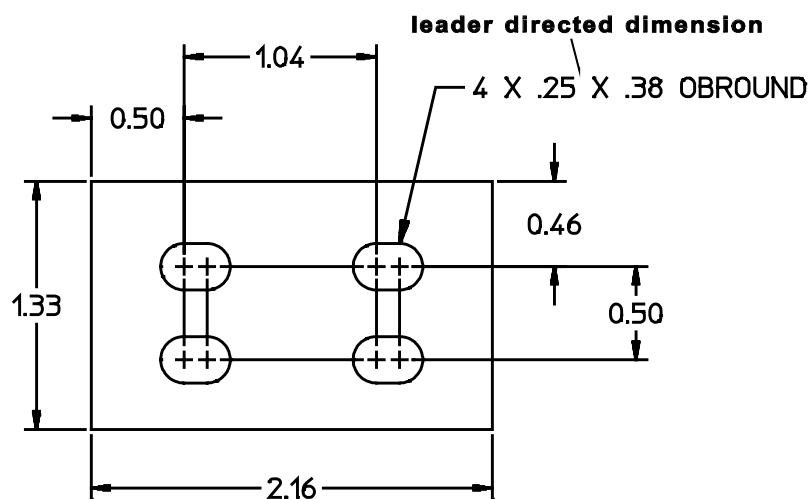

**Figure 8 - Leader directed dimension**

EXPRESS specification:

```

*)
ENTITY leader_directed_dimension
  SUBTYPE OF (leader_directed_callout);
WHERE
  WR1: SIZEOF (QUERY (con <* SELF.contents |
    'AIC_DRAUGHTING_ELEMENTS.LEADER_CURVE' IN TYPEOF (con)))=1;
END_ENTITY;
(*

```

Formal propositions:

**WR1:** The contents of a **leader\_directed\_dimension** shall contain exactly one **leader\_curve**.

### 4.1.12 linear\_dimension

A **linear\_dimension** is a **draughting\_callout** directed by a dimension curve that presents a value of distance between two elements, measured along a linear path, or the length of a linear element.

NOTE - Figures 3, 6, 7, and 8 show several linear dimensions used singularly or in dimension pairs.

EXPRESS specification:

```

*)
ENTITY linear_dimension
  SUBTYPE OF (dimension_curve_directed_callout);
END_ENTITY;
(*

```

### 4.1.13 ordinate\_dimension

An **ordinate\_dimension** is a **draughting\_callout** directed by a projection curve that presents a dimension value.

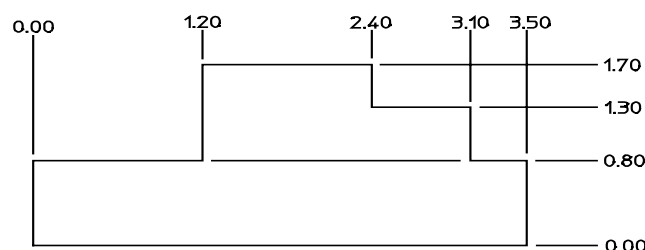

**Figure 9 - Ordinate dimension**

NOTE - Figure 9 illustrates several ordinate dimensions used to dimension a simple mechanical product.

EXPRESS specification:

```

*)
ENTITY ordinate_dimension
  SUBTYPE OF (projection_directed_callout);
END_ENTITY;
(*

```

**4.1.14 radius\_dimension**

A **radius\_dimension** is a **draughting\_callout** directed by a dimension curve that presents a value of the radial size of a circular element.

NOTE - Figure 1 illustrates a radius dimension. The figure also illustrates three angular dimensions.

EXPRESS specification:

```

*)
ENTITY radius_dimension
  SUBTYPE OF (dimension_curve_directed_callout);
WHERE
  WR1: SIZEOF (QUERY (con <* SELF.contents |
    'AIC_DRAUGHTING_ELEMENTS.PROJECTION_CURVE' IN TYPEOF (con)))<=1;
END_ENTITY;
(*

```

Formal propositions:

**WR1:** The **contents** of a **radius\_dimension** shall contain at most one **projection\_curve**.

**4.1.15 structured\_dimension\_callout**

A **structured\_dimension\_callout** is a **draughting\_callout** that presents information associated with a dimension, in which individual elements presenting different components of the dimensional information may be identified and distinguished.

NOTE - Figure 5 illustrates components of a structured dimension callout. The dimension callout contains curves, symbols, and text. Text is identified as the dimension value, tolerance value, or unit text. Other draughting callouts can be identified as prefix or suffix information by use of **dimension\_callout\_component - relationship**.

EXPRESS specification:

```

*)
ENTITY structured_dimension_callout
  SUBTYPE OF (draughting_callout);
WHERE
  WR1: SIZEOF (TYPEOF (SELF) *
    ['AIC_DRAUGHTING_ELEMENTS.DATUM_FEATURE_CALLOUT',
    'AIC_DRAUGHTING_ELEMENTS.DATUM_TARGET_CALLOUT',
    'AIC_DRAUGHTING_ELEMENTS.GEOMETRICAL_TOLERANCE_CALLOUT',
    'AIC_DRAUGHTING_ELEMENTS.LEADER_DIRECTED_CALLOUT',
    'AIC_DRAUGHTING_ELEMENTS.PROJECTION_DIRECTED_CALLOUT',
    'AIC_DRAUGHTING_ELEMENTS.DIMENSION_CURVE_DIRECTED_CALLOUT']) = 0;

```

```

WR2: SIZEOF (QUERY (ato <* QUERY (con <* SELF.contents |
  ('AIC_DRAUGHTING_ELEMENTS.ANNOTATION_TEXT_OCCURRENCE'
   IN TYPEOF (con))) |
  NOT (ato.name IN
    ['dimension value', 'tolerance value', 'unit text',
     'prefix text', 'suffix text']))) = 0;
WR3: SIZEOF (QUERY (ato <* QUERY (con <* SELF.contents |
  ('AIC_DRAUGHTING_ELEMENTS.ANNOTATION_TEXT_OCCURRENCE'
   IN TYPEOF (con))) |
  (ato.name = 'dimension value')
)) >= 1;
WR4: SIZEOF (QUERY (dcr <* USEDIN (SELF, 'AIC_DRAUGHTING_ELEMENTS.' +
  'DRAUGHTING_CALLOUT_RELATIONSHIP.' +
  'RELATING_DRAUGHTING_CALLOUT') |
  ('AIC_DRAUGHTING_ELEMENTS.' +
   'DIMENSION_CALLOUT_COMPONENT_RELATIONSHIP' IN TYPEOF (dcr)) AND
  (dcr.name = 'prefix') )) <= 1;
WR5: SIZEOF (QUERY (dcr <* USEDIN (SELF, 'AIC_DRAUGHTING_ELEMENTS.' +
  'DRAUGHTING_CALLOUT_RELATIONSHIP.' +
  'RELATING_DRAUGHTING_CALLOUT') |
  ('AIC_DRAUGHTING_ELEMENTS.' +
   'DIMENSION_CALLOUT_COMPONENT_RELATIONSHIP' IN TYPEOF (dcr)) AND
  (dcr.name = 'suffix') )) <= 1;
WR6: NOT((SIZEOF (QUERY (ato <* QUERY (con <* SELF.contents |
  ('AIC_DRAUGHTING_ELEMENTS.ANNOTATION_TEXT_OCCURRENCE'
   IN TYPEOF (con))) |
  (ato.name = 'prefix text')
)) > 0)) OR
  (SIZEOF (QUERY (dcr <* USEDIN (SELF, 'AIC_DRAUGHTING_ELEMENTS.' +
    'DRAUGHTING_CALLOUT_RELATIONSHIP.' +
    'RELATING_DRAUGHTING_CALLOUT') |
    ('AIC_DRAUGHTING_ELEMENTS.' +
     'DIMENSION_CALLOUT_COMPONENT_RELATIONSHIP' IN TYPEOF (dcr)) AND
    (dcr.name = 'prefix') )) = 1);
WR7: NOT((SIZEOF (QUERY (ato <* QUERY (con <* SELF.contents |
  ('AIC_DRAUGHTING_ELEMENTS.ANNOTATION_TEXT_OCCURRENCE'
   IN TYPEOF (con))) |
  (ato.name = 'suffix text')
)) > 0)) OR
  (SIZEOF (QUERY (dcr <* USEDIN (SELF, 'AIC_DRAUGHTING_ELEMENTS.' +
    'DRAUGHTING_CALLOUT_RELATIONSHIP.' +
    'RELATING_DRAUGHTING_CALLOUT') |
    ('AIC_DRAUGHTING_ELEMENTS.' +
     'DIMENSION_CALLOUT_COMPONENT_RELATIONSHIP' IN TYPEOF (dcr)) AND
    (dcr.name = 'suffix') )) = 1);

END_ENTITY;
(*

```

#### Formal propositions:

**WR1:** The **structured\_dimension\_callout** shall not be a **datum\_feature\_callout**, **datum\_target\_callout**, **geometrical\_tolerance\_callout**, **leader\_directed\_callout**, **projection\_directed\_callout**, or **dimension\_curve\_directed\_callout**.

**WR2:** Each **annotation\_text\_occurrence** in the **structured\_dimension\_callout** shall have a **name** of “dimension value”, “tolerance value”, “unit text”, “prefix text”, or “suffix text”.

**WR3:** The **contents** of the **structured\_dimension\_callout** shall contain at least one **annotation\_text\_occurrence** that shall have a name of “dimension value”.



**WR4:** The **structured\_dimension\_callout** shall participate as the dimension callout in at most one **dimension\_callout\_component\_relationship** with **name** of “prefix”.

**WR5:** The **structured\_dimension\_callout** shall participate as the dimension callout in at most one **dimension\_callout\_component\_relationship** with **name** of “suffix”.

**WR6:** If the **contents** of the **structured\_dimension\_callout** contain an **annotation\_text\_occurrence** that is “prefix text”, then the **structured\_dimension\_callout** shall participate as the dimension callout in a **dimension\_callout\_component\_relationship** with **name** of “prefix”.

**WR7:** If the **contents** of the **structured\_dimension\_callout** contain an **annotation\_text\_occurrence** that is “suffix text”, then the **structured\_dimension\_callout** shall participate as the dimension callout in a **dimension\_callout\_component\_relationship** with **name** of “suffix”.

```
*)  
END_SCHEMA; -- aic_draughting_elements  
(*
```

## Annex A (normative)

### Short names of entities

Table A.1 provides the short names of entities specified in this part of ISO 10303. Requirements on the use of the short names are found in the implementation methods included in ISO 10303.

**Table A.1 - Short names of entities**

Entity names	Short names
ANGULAR_DIMENSION	ANGDMN
CURVE_DIMENSION	CRVDMN
DATUM_FEATURE_CALLOUT	DTFTCL
DATUM_TARGET_CALLOUT	DTTRCL
DIAMETER_DIMENSION	DMTDMN
DIMENSION_CALLOUT_COMPONENT_RELATIONSHIP	DCCR
DIMENSION_CALLOUT_RELATIONSHIP	DMCLRL
DIMENSION_PAIR	DMNPR
DRAUGHTING_ELEMENTS	DRGELM
GEOMETRICAL_TOLERANCE_CALLOUT	GMTLCL
LEADER_DIRECTED_DIMENSION	LDDRDM
LINEAR_DIMENSION	LNRDMN
ORDINATE_DIMENSION	ORDDMN
RADIUS_DIMENSION	RDSDMN
STRUCTURED_DIMENSION_CALLOUT	STDMCL

## **Annex B** (normative)

### **Information object registration**

#### **B.1 Document identification**

To provide for unambiguous identification of an information object in an open system, the object identifier

{ iso standard 10303 part(506) version(1) }

is assigned to this part of ISO 10303. The meaning of this value is defined in ISO/IEC 8824-1, and is described in ISO 10303-1.

#### **B.2 Schema identification**

To provide for unambiguous identification of the `aic_draughting_elements` in an open system, the object identifier

{ iso standard 10303 part(506) version(1) object(1) aic-draughting-elements(1) }

is assigned to the `aic_draughting_elements` schema (see clause 4). The meaning of this value is defined in ISO/IEC 8824-1, and is described in ISO 10303-1.

## Annex C (informative)

### EXPRESS-G diagrams

Figures C.1 through C.4 correspond to the EXPRESS generated from the short listing given in clause 4 using the interface specifications of ISO 10303-11. The diagrams use the EXPRESS-G graphical notation for the EXPRESS language. EXPRESS-G is defined in annex D of ISO 10303-11.

NOTE - The following select types: `curve_or_annotation_curve_occurrence`, `style_context_select`, `founded_item_select`, `invisible_item` are interfaced into the AIC expanded listing according to the implicit interface rules of ISO 10303-11. These select types are not referenced by other entities of this part of ISO 10303.

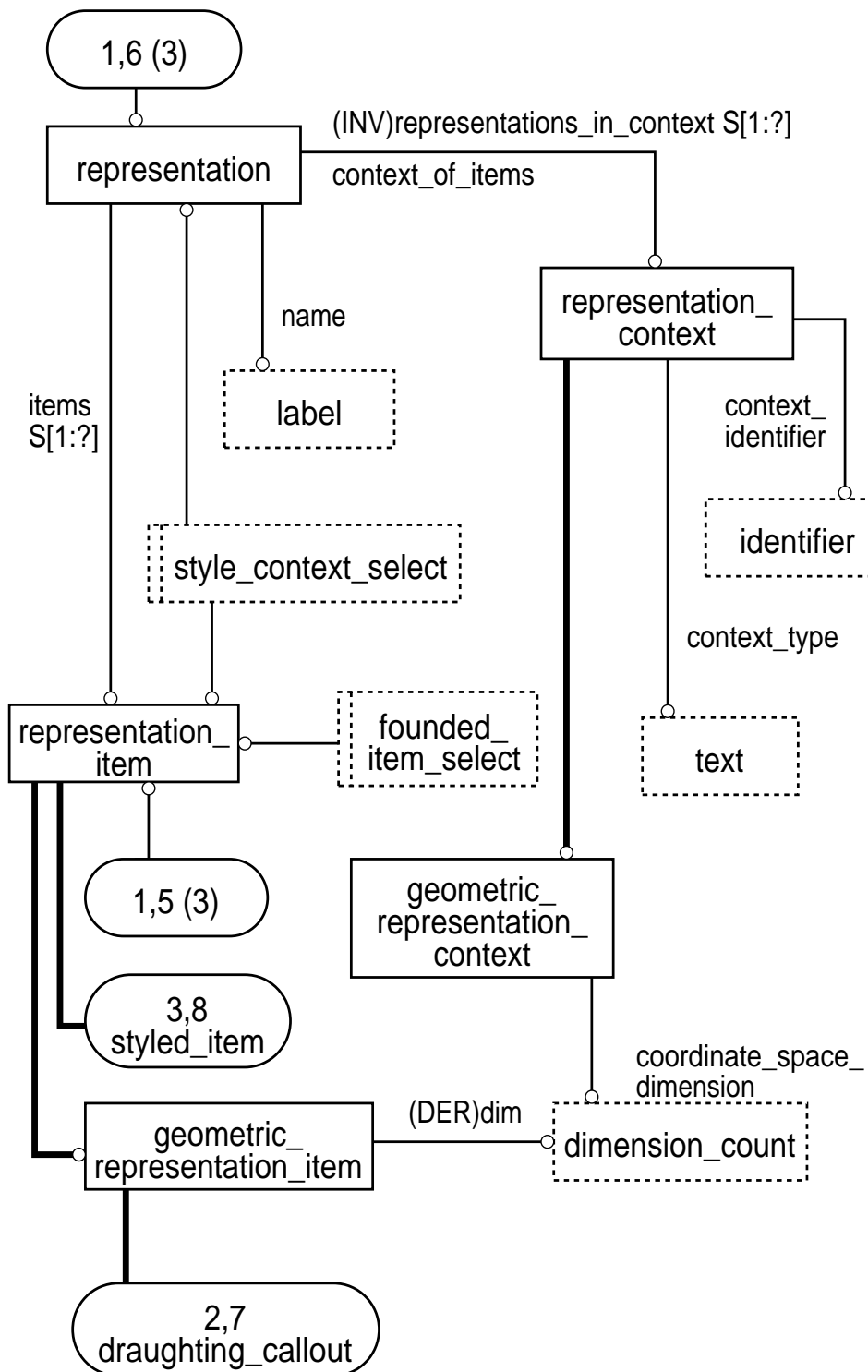

Figure C.1 - AIC expanded listing diagram in EXPRESS-G: 1 of 4

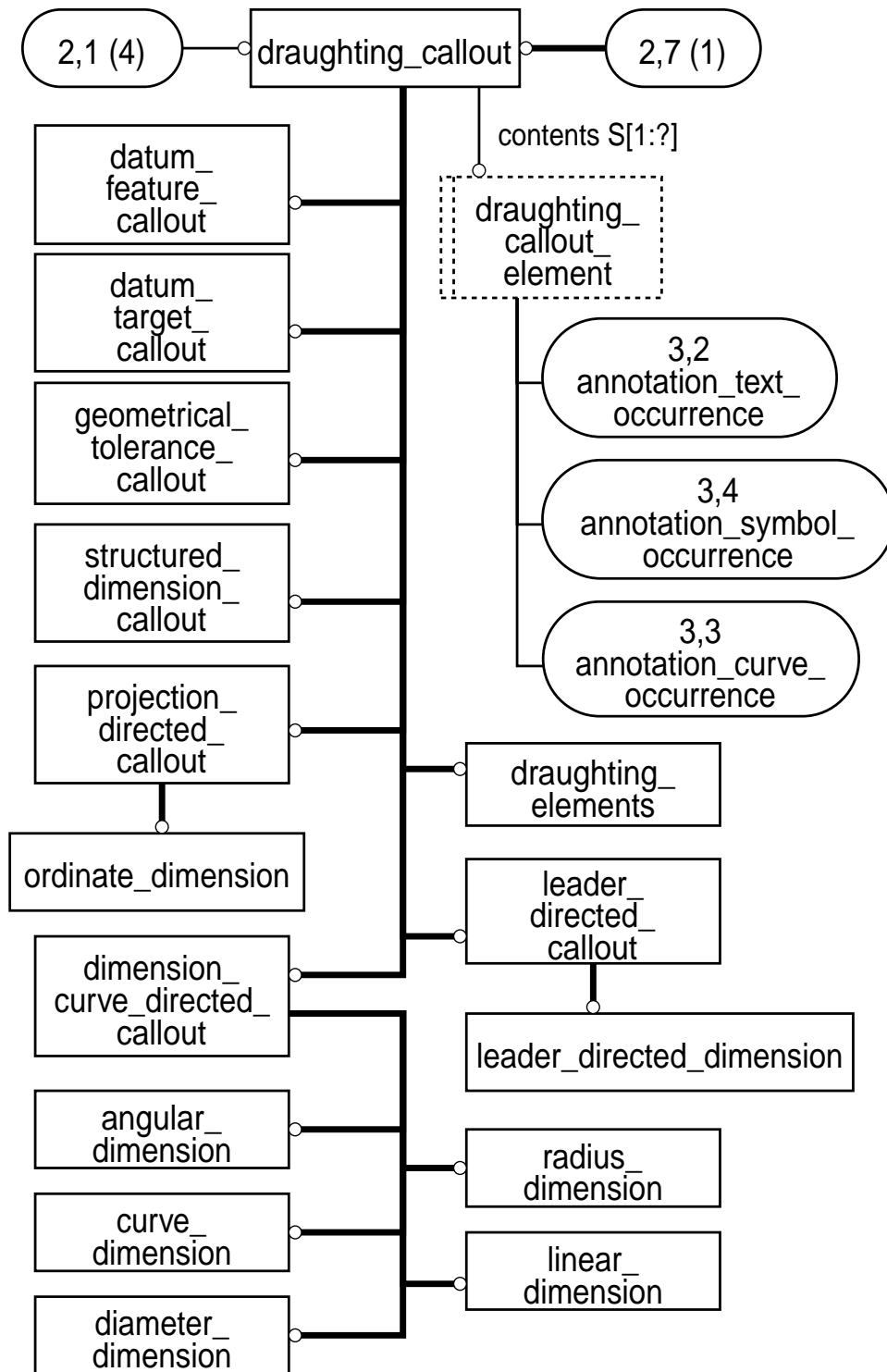

Figure C.2 - AIC expanded listing diagram in EXPRESS-G: 2 of 4

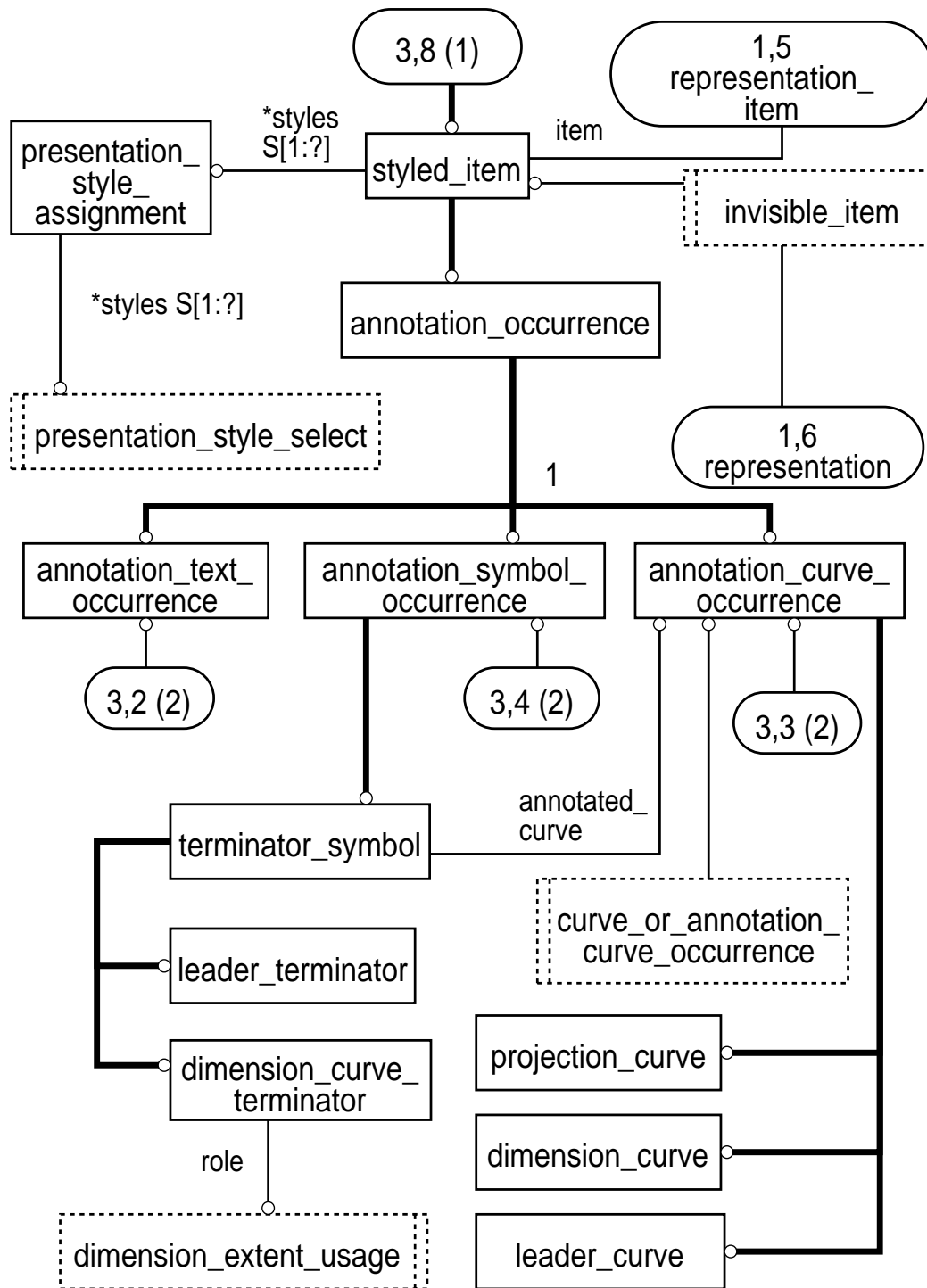
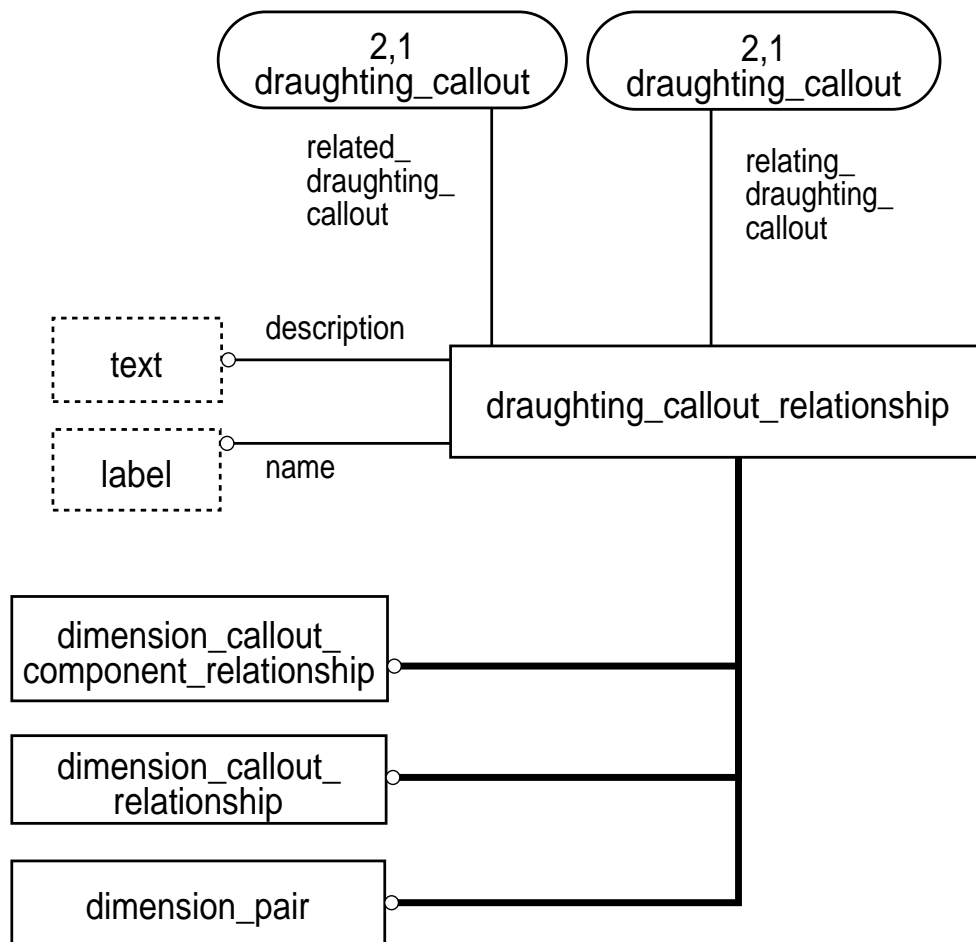

Figure C.3 - AIC expanded listing diagram in EXPRESS-G: 3 of 4



**Figure C.4 - AIC expanded listing diagram in EXPRESS-G: 4 of 4**



## **Annex D** **(informative)**

### **Computer interpretable listings**

This annex references a listing of the EXPRESS entity names and corresponding short names as specified in this part of ISO 10303. It also provides a listing of each EXPRESS schema specified in this part of ISO 10303 without comments or other explanatory text. These listings are available in computer-interpretable form and can be found at the following URLs:

Short names: <http://www.mel.nist.gov/div826/subject/apde/snr/>  
EXPRESS: <http://www.mel.nist.gov/step/parts/part506/IS/>

If there is difficulty accessing these sites contact ISO Central Secretariat or contact the ISO TC 184/SC4 Secretariat directly at: [sc4sec@cme.nist.gov](mailto:sc4sec@cme.nist.gov).

NOTE - The information provided in computer-interpretable form at the above URLs is informative. The information that is contained in the body of this part of ISO 10303 is normative.

## Index

angular_dimension	
AIC diagrams .....	24
AIC EXPRESS short listing entities .....	5
annotation_curve_occurrence	
AIC diagrams .....	25
annotation_occurrence	
AIC diagrams .....	25
annotation_symbol_occurrence	
AIC diagrams .....	25
annotation_text_occurrence	
AIC diagrams .....	25
curve_dimension	
AIC diagrams .....	24
AIC EXPRESS short listing entities .....	6
curve_or_annotation_curve_occurrence	
AIC diagrams .....	25
datum_feature_callout	
AIC diagrams .....	24
AIC EXPRESS short listing entities .....	7
datum_target_callout	
AIC diagrams .....	25
AIC EXPRESS short listing entities .....	7
diameter_dimension	
AIC diagrams .....	24
AIC EXPRESS short listing entities .....	8
dimension_value .....	4
dimension_callout_component_relationship	
AIC diagrams .....	26
AIC EXPRESS short listing entities .....	8
dimension_callout_relationship	
AIC diagrams .....	26
AIC EXPRESS short listing entities .....	11
dimension_count	
AIC diagrams .....	23
dimension_curve	
AIC diagrams .....	25
dimension_curve_directed_callout	
AIC diagrams .....	24
dimension_curve_terminator	
AIC diagrams .....	25
dimension_extent_usage	
AIC diagrams .....	25
dimension_pair	
AIC diagrams .....	26
AIC EXPRESS short listing entities .....	12
draughting_callout	
AIC diagrams .....	24
draughting_element	
AIC diagrams .....	24
draughting_callout_relationship	
AIC diagrams .....	26

draughting_elements	
AIC diagrams .....	24
AIC EXPRESS short listing entities .....	13
founded_item_select	
AIC diagrams .....	23
geometric_representation_context	
AIC diagrams .....	23
geometric_representation_item	
AIC diagrams .....	23
geometrical_tolerance_callout	
AIC diagrams .....	23
AIC EXPRESS short listing entities .....	13
identifier	
AIC diagrams .....	23
invisible_item	
AIC diagrams .....	25
label	
AIC diagrams .....	23
leader_curve	
AIC diagrams .....	25
leader_directed_callout	
AIC diagrams .....	24
leader_directed_dimension	
AIC diagrams .....	24
AIC EXPRESS short listing entities .....	14
leader_terminator	
AIC diagrams .....	25
linear_dimension	
AIC diagrams .....	24
AIC EXPRESS short listing entities .....	15
ordinate_dimension	
AIC diagrams .....	24
AIC EXPRESS short listing entities .....	15
presentation_style_assignment	
AIC diagrams .....	25
presentation_style_select	
AIC diagrams .....	25
projection_curve	
AIC diagrams .....	25
projection_directed_callout	
AIC diagrams .....	24
radius_dimension	
AIC diagrams .....	24
AIC EXPRESS short listing entities .....	15
representation	
AIC diagrams .....	23
representation_context	
AIC diagrams .....	23

representation_item	
AIC diagrams .....	23
structured_dimension_callout	
AIC diagrams .....	24
AIC EXPRESS short listing entities .....	16
styled_item	
AIC diagrams .....	25
style_context_select	
AIC diagrams .....	23
terminator_symbol	
AIC diagrams .....	25
text	
AIC diagrams .....	23



.....

---

---

**ICS 25.040.40**

Price based on 30 pages

© ISO 2000 – All rights reserved