

---

---

**Industrial automation systems  
and integration — Product data  
representation and exchange —**

Part 238:

**Application protocol: Application  
interpreted model for computerized  
numerical controllers**

*Systèmes d'automatisation industrielle et intégration — Représentation  
et échange de données de produits —*

*Partie 238: Protocole d'application: Modèle d'application interprété pour  
des contrôleurs numériques informatisés*



Reference number  
ISO 10303-238:2007(E)

© ISO 2007

**PDF disclaimer**

This PDF file may contain embedded typefaces. In accordance with Adobe's licensing policy, this file may be printed or viewed but shall not be edited unless the typefaces which are embedded are licensed to and installed on the computer performing the editing. In downloading this file, parties accept therein the responsibility of not infringing Adobe's licensing policy. The ISO Central Secretariat accepts no liability in this area.

Adobe is a trademark of Adobe Systems Incorporated.

Details of the software products used to create this PDF file can be found in the General Info relative to the file; the PDF-creation parameters were optimized for printing. Every care has been taken to ensure that the file is suitable for use by ISO member bodies. In the unlikely event that a problem relating to it is found, please inform the Central Secretariat at the address given below.



**COPYRIGHT PROTECTED DOCUMENT**

© ISO 2007

All rights reserved. Unless otherwise specified, no part of this publication may be reproduced or utilized in any form or by any means, electronic or mechanical, including photocopying and microfilm, without permission in writing from either ISO at the address below or ISO's member body in the country of the requester.

ISO copyright office  
Case postale 56 • CH-1211 Geneva 20  
Tel. + 41 22 749 01 11  
Fax + 41 22 749 09 47  
E-mail [copyright@iso.org](mailto:copyright@iso.org)  
Web [www.iso.org](http://www.iso.org)

Published in Switzerland

<b>Contents</b>	<b>page</b>
1 Scope .....	1
2 Normative references .....	2
3 Terms and definitions .....	5
3.1 Terms defined in ISO 1101 .....	5
3.2 Terms defined in ISO 2806 .....	5
3.3 Terms defined in ISO 5459 .....	5
3.4 Terms defined in ISO 10303-1 .....	5
3.5 Terms defined in ISO 10303-11 .....	6
3.6 Terms defined in ISO 14649-1 .....	6
3.7 Terms defined in ISO 14649-10 .....	6
3.8 Terms defined in ISO 14649-11 .....	6
4 Information requirements .....	7
4.1 Units of functionality .....	7
4.1.1 measure .....	8
4.1.2 project .....	9
4.1.3 workpiece .....	9
4.1.4 manufacturing feature .....	10
4.1.5 executable .....	15
4.1.6 operation .....	17
4.1.7 toolpath .....	18
4.1.8 process data for milling .....	19
4.1.9 cutting tools for milling .....	22
4.1.10 turning feature .....	23
4.1.11 process data for turning .....	24
4.1.12 cutting tools for turning .....	25
4.1.13 geometric dimensioning and tolerancing .....	26
4.1.14 library reference .....	28
4.1.15 management .....	29
4.2 Application objects .....	30
4.3 Application assertions .....	195
5 Application interpreted model .....	205
5.1 Mapping table .....	205
5.2 AIM EXPRESS short listing .....	767
5.2.1 Fundamental concepts and assumptions .....	774
5.2.2 Integrated CNC types .....	807
5.2.3 Integrated CNC entities .....	810
5.2.4 Integrated CNC rule definitions .....	929
5.2.5 Integrated CNC function definitions .....	939
6 Conformance requirements .....	975
6.1 Conformance Class for tool path programming (CC1) .....	975
6.2 Conformance Class for closed-loop programming (CC2) .....	977
6.3 Conformance Class for feature-based programming (CC3) .....	977
6.4 Conformance Class for generative programming (CC4) .....	977

Annex A (normative) AIM EXPRESS expanded listing .....	996
Annex B (normative) AIM short names .....	1269
Annex C (normative) Implementation method-specific requirements .....	1289
C.1 Requirements specific to ISO 10303-21 .....	1289
C.2 Requirements specific to ISO 10303-28 .....	1289
Annex D (normative) Protocol Implementation Conformance Statement (PICS) proforma .....	1291
Annex E (normative) Information object registration .....	1294
E.1 Document identification .....	1294
E.2 Schema identification .....	1294
Annex F (informative) Application activity model .....	1295
Annex G (informative) Application reference model .....	1296
Annex H (informative) AIM EXPRESS-G .....	1346
Annex I (informative) Computer interpretable listings .....	1412
Annex J (informative) Annotated examples .....	1414
J.1 Introduction .....	1414
J.2 Annotation conventions .....	1414
J.3 Machining project for CC1 and CC2 examples .....	1416
J.4 Data set for CC1 example .....	1416
J.5 Data set for CC2 example .....	1434
J.6 Data set for ISO 14649-11 example #1 (CC3) .....	1464
J.7 Data set for ISO 14649-12 example #1 (CC3) .....	1496
Bibliography .....	1518
Index .....	1520

<b>Figures</b>	<b>page</b>
Figure 1 — Angular_location_dimension .....	31
Figure 2 — Angular_location_dimension versus Angular_size_dimension .....	32
Figure 3 — Angular_size_dimension .....	33
Figure 4 — Angularity_tolerance .....	33
Figure 5 — Circular_runout_tolerance .....	51
Figure 6 — Coaxiality_tolerance .....	53
Figure 7 — Concentricity_tolerance .....	57
Figure 8 — Curved_distance_dimension .....	63
Figure 9 — Curved_size_dimension .....	64



Figure 10 — Toolpath deviation parameters .....	65
Figure 11 — Cylindricity_tolerance .....	68
Figure 12 — Diameter_size_dimension .....	72
Figure 13 — Flatness_tolerance .....	81
Figure 14 — Line_profile_tolerance .....	99
Figure 15 — Linear_distance_dimension .....	100
Figure 16 — Parallelism_tolerance .....	119
Figure 17 — Perpendicularity_tolerance .....	122
Figure 18 — Planar_face parameters .....	123
Figure 19 — Pocket (bottom at path origin) .....	128
Figure 20 — Pocket (bottom at path end) .....	129
Figure 21 — Position_tolerance .....	130
Figure 22 — Radial_size_dimension .....	136
Figure 23 — Round_hole (bottom at path origin) .....	142
Figure 24 — Round_hole (bottom at path end) .....	142
Figure 25 — Rounded_u_profile parameters .....	145
Figure 26 — Roundness_tolerance .....	145
Figure 27 — Square_u_profile parameters .....	153
Figure 28 — Straightness_tolerance .....	154
Figure 29 — Surface_profile_tolerance .....	155
Figure 30 — Symmetry_tolerance .....	157
Figure 31 — Thickness_size_dimension .....	161
Figure 32 — Tolerance_zone .....	165
Figure 33 — Total_runout_tolerance .....	172
Figure 34 — User_defined_milling_tool parameters .....	181
Figure 35 — Vee_profile parameters .....	185
Figure 36 — Profile and path definition of features .....	775
Figure 37 — Feature placement differences .....	776
Figure 38 — Feature placement differences .....	778
Figure 39 — AIM Instances for implicit and explicit feature shape .....	779
Figure 40 — Alternate machining processes and features .....	781
Figure 41 — Example of process and final form features .....	781
Figure 42 — Planar face origin and parameters .....	782
Figure 43 — Round hole origin .....	783
Figure 44 — Pocket origin .....	784
Figure 45 — General Outside profile origin .....	785
Figure 46 — Shape profile origin .....	785
Figure 47 — Slot origin and orientation .....	786
Figure 48 — Step origin and orientation .....	787
Figure 49 — Transition features relating faces or features .....	788
Figure 50 — Toolpath with complete circle .....	806
Figure G.1 — ARM diagram (1 of 48) .....	1297
Figure G.2 — ARM diagram (2 of 48) .....	1298
Figure G.3 — ARM diagram (3 of 48) .....	1299
Figure G.4 — ARM diagram (4 of 48) .....	1300
Figure G.5 — ARM diagram (5 of 48) .....	1301
Figure G.6 — ARM diagram (6 of 48) .....	1302
Figure G.7 — ARM diagram (7 of 48) .....	1303
Figure G.8 — ARM diagram (8 of 48) .....	1304

Figure G.9 — ARM diagram (9 of 48)	1305
Figure G.10 — ARM diagram (10 of 48)	1306
Figure G.11 — ARM diagram (11 of 48)	1307
Figure G.12 — ARM diagram (12 of 48)	1308
Figure G.13 — ARM diagram (13 of 48)	1309
Figure G.14 — ARM diagram (14 of 48)	1310
Figure G.15 — ARM diagram (15 of 48)	1311
Figure G.16 — ARM diagram (16 of 48)	1312
Figure G.17 — ARM diagram (17 of 48)	1313
Figure G.18 — ARM diagram (18 of 48)	1314
Figure G.19 — ARM diagram (19 of 48)	1315
Figure G.20 — ARM diagram (20 of 48)	1316
Figure G.21 — ARM diagram (21 of 48)	1317
Figure G.22 — ARM diagram (22 of 48)	1318
Figure G.23 — ARM diagram (23 of 48)	1319
Figure G.24 — ARM diagram (24 of 48)	1320
Figure G.25 — ARM diagram (25 of 48)	1321
Figure G.26 — ARM diagram (26 of 48)	1322
Figure G.27 — ARM diagram (27 of 48)	1323
Figure G.28 — ARM diagram (28 of 48)	1324
Figure G.29 — ARM diagram (29 of 48)	1325
Figure G.30 — ARM diagram (30 of 48)	1326
Figure G.31 — ARM diagram (31 of 48)	1327
Figure G.32 — ARM diagram (32 of 48)	1328
Figure G.33 — ARM diagram (33 of 48)	1329
Figure G.34 — ARM diagram (34 of 48)	1330
Figure G.35 — ARM diagram (35 of 48)	1331
Figure G.36 — ARM diagram (36 of 48)	1332
Figure G.37 — ARM diagram (37 of 48)	1333
Figure G.38 — ARM diagram (38 of 48)	1334
Figure G.39 — ARM diagram (39 of 48)	1335
Figure G.40 — ARM diagram (40 of 48)	1336
Figure G.41 — ARM diagram (41 of 48)	1337
Figure G.42 — ARM diagram (42 of 48)	1338
Figure G.43 — ARM diagram (43 of 48)	1339
Figure G.44 — ARM diagram (44 of 48)	1340
Figure G.45 — ARM diagram (45 of 48)	1341
Figure G.46 — ARM diagram (46 of 48)	1342
Figure G.47 — ARM diagram (47 of 48)	1343
Figure G.48 — ARM diagram (48 of 48)	1344
Figure H.1 — AIM EXPRESS-G diagram action method	1347
Figure H.2 — AIM EXPRESS-G diagram machining operation subtypes	1348
Figure H.3 — AIM EXPRESS-G diagram action method relationship	1349
Figure H.4 — AIM EXPRESS-G diagram action method relationship subtypes	1350
Figure H.5 — AIM EXPRESS-G diagram action	1351
Figure H.6 — AIM EXPRESS-G diagram action resource	1352
Figure H.7 — AIM EXPRESS-G diagram action resource requirement	1353
Figure H.8 — AIM EXPRESS-G diagram action property	1354
Figure H.9 — AIM EXPRESS-G diagram resource property	1355

Figure H.10 — AIM EXPRESS-G diagram product	1356
Figure H.11 — AIM EXPRESS-G diagram product category	1357
Figure H.12 — AIM EXPRESS-G diagram product context	1358
Figure H.13 — AIM EXPRESS-G diagram product definition relationship	1359
Figure H.14 — AIM EXPRESS-G diagram property definition	1360
Figure H.15 — AIM EXPRESS-G diagram property definition representation	1361
Figure H.16 — AIM EXPRESS-G diagram externally defined item	1362
Figure H.17 — AIM EXPRESS-G diagram identification assignment	1363
Figure H.18 — AIM EXPRESS-G diagram representation	1364
Figure H.19 — AIM EXPRESS-G diagram shape representation	1365
Figure H.20 — AIM EXPRESS-G diagram representation context	1366
Figure H.21 — AIM EXPRESS-G diagram representation item	1367
Figure H.22 — AIM EXPRESS-G diagram representation relationship	1368
Figure H.23 — AIM EXPRESS-G diagram transformation	1369
Figure H.24 — AIM EXPRESS-G diagram geometric representation item	1370
Figure H.25 — AIM EXPRESS-G diagram points	1371
Figure H.26 — AIM EXPRESS-G diagram placement	1372
Figure H.27 — AIM EXPRESS-G diagram surface	1373
Figure H.28 — AIM EXPRESS-G diagram bounded surface	1374
Figure H.29 — AIM EXPRESS-G diagram b-spline surface	1375
Figure H.30 — AIM EXPRESS-G diagram other surface	1376
Figure H.31 — AIM EXPRESS-G diagram block and cylinder	1377
Figure H.32 — AIM EXPRESS-G diagram curve	1378
Figure H.33 — AIM EXPRESS-G diagram conic	1379
Figure H.34 — AIM EXPRESS-G diagram composite curve	1380
Figure H.35 — AIM EXPRESS-G diagram b-spline curve	1381
Figure H.36 — AIM EXPRESS-G diagram topological representation item	1382
Figure H.37 — AIM EXPRESS-G diagram edge, loop, and path	1383
Figure H.38 — AIM EXPRESS-G diagram connected face set	1384
Figure H.39 — AIM EXPRESS-G diagram shell	1385
Figure H.40 — AIM EXPRESS-G diagram shape aspect	1386
Figure H.41 — AIM EXPRESS-G diagram characterized object	1387
Figure H.42 — AIM EXPRESS-G diagram shape aspect relationship	1388
Figure H.43 — AIM EXPRESS-G diagram datum	1389
Figure H.44 — AIM EXPRESS-G diagram geometric tolerance	1390
Figure H.45 — AIM EXPRESS-G diagram dimensional size	1391
Figure H.46 — AIM EXPRESS-G diagram tolerance zone	1392
Figure H.47 — AIM EXPRESS-G diagram measure with unit	1393
Figure H.48 — AIM EXPRESS-G diagram measure value	1394
Figure H.49 — AIM EXPRESS-G diagram qualified representation item	1395
Figure H.50 — AIM EXPRESS-G diagram unit	1396
Figure H.51 — AIM EXPRESS-G diagram generic expression	1397
Figure H.52 — AIM EXPRESS-G diagram expression	1398
Figure H.53 — AIM EXPRESS-G diagram person and organization	1399
Figure H.54 — AIM EXPRESS-G diagram organization assignment	1400
Figure H.55 — AIM EXPRESS-G diagram address	1401
Figure H.56 — AIM EXPRESS-G diagram date and time	1402
Figure H.57 — AIM EXPRESS-G diagram date and time assignment	1403
Figure H.58 — AIM EXPRESS-G diagram document	1404

Figure H.59 — AIM EXPRESS-G diagram document reference .....	1405
Figure H.60 — AIM EXPRESS-G diagram approval .....	1406
Figure H.61 — AIM EXPRESS-G diagram security classification .....	1407
Figure H.62 — AIM EXPRESS-G diagram classification assignment .....	1408
Figure H.63 — AIM EXPRESS-G diagram name and id attribute .....	1409
Figure H.64 — AIM EXPRESS-G diagram description attribute .....	1410
Figure H.65 — AIM EXPRESS-G diagram additional types .....	1411
Figure J.1 — Example workpiece and toolpath .....	1416
Figure J.2 — Workpiece from ISO 14649-11 example #1 .....	1465
Figure J.3 — Workpiece from ISO 14649-12 example #1 .....	1496

<b>Tables</b>	<b>page</b>
Table 1 — Mapping table for measure UoF .....	207
Table 2 — Mapping table for project UoF .....	217
Table 3 — Mapping table for workpiece UoF .....	220
Table 4 — Mapping table for manufacturing features UoF .....	243
Table 5 — Mapping table for executable UoF .....	420
Table 6 — Mapping table for operation UoF .....	473
Table 7 — Mapping table for toolpath UoF .....	479
Table 8 — Mapping table for process data for milling UoF .....	503
Table 9 — Mapping table for cutting tools for milling UoF .....	587
Table 10 — Mapping table for turning features UoF .....	625
Table 11 — Mapping table for process data for turning UoF .....	648
Table 12 — Mapping table for cutting tools for turning UoF .....	689
Table 13 — Mapping table for geometric dimensioning and tolerancing UoF .....	718
Table 14 — Mapping table for library reference UoF .....	750
Table 15 — Mapping table for management UoF .....	758
Table 16 — Conformance class elements .....	978
Table B.1 — AIM short names of entities .....	1269

## Foreword

ISO (the International Organization for Standardization) is a worldwide federation of national standards bodies (ISO member bodies). The work of preparing International Standards is normally carried out through ISO technical committees. Each member body interested in a subject for which a technical committee has been established has the right to be represented on that committee. International organizations, governmental and non-governmental, in liaison with ISO, also take part in the work. ISO collaborates closely with the International Electrotechnical Commission (IEC) on all matters of electrotechnical standardizations.

International Standards are drafted in accordance with the rules given in the ISO/IEC Directives, Part 2.

The main task of technical committees is to prepare International Standards. Draft International Standards adopted by the technical committees are circulated to the member bodies for voting. Publication as an International Standard requires approval by at least 75 % of the member bodies casting a vote.

Attention is drawn to the possibility that some of the elements of this document may be the subject of patent rights. ISO shall not be held responsible for identifying any or all such patent rights.

ISO 10303-238 was prepared by Technical Committee ISO TC184/SC4, *Industrial automation systems and integration*, Subcommittee SC4 *Industrial data*.

ISO 10303 is organized as a series of parts, each published separately. The structure of ISO 10303 is described in ISO 10303-1.

Each part of ISO 10303 is a member of one of the following series: description methods, implementation methods, conformance testing methodology and framework, integrated generic resources, integrated application resources, application protocols, abstract test suites, application interpreted constructs, and application modules. ISO 10303-238 is a member of the application protocols series.

A complete list of parts of ISO 10303 is available from the following URL:

[http://www.tc184-sc4.org/titles/STEP\\_Titles.htm](http://www.tc184-sc4.org/titles/STEP_Titles.htm)

## Introduction

ISO 10303 is an International Standard for the computer-interpretable representation of product information and for the exchange of product data. The objective is to provide a neutral mechanism capable of describing products throughout their life cycle. This mechanism is suitable not only for neutral file exchange, but also as a basis for implementing and sharing product databases, and as a basis for archiving.

This part of ISO 10303 is a member of the application protocol series. This part of ISO 10303 specifies an application protocol (AP) for numerical controlled machining and associated processes, including the scope and information requirements defined by the ISO 14649 data model for numerical controllers, augmented with product geometry, geometric dimensioning and tolerancing, and product data management information.

ISO 14649 defines a richer model for information transfer between CAD/CAM systems and computerized numerical control (CNC) machines than that of the older ISO 6983 “G and M code” language. ISO 6983-1 [2] describes the path of the tool centre point with respect to machine axes. ISO 14649 describes machining processes with respect to a part, including part geometry, manufacturing features, sequencing of operations, associated process parameters, and tool requirements.

This part of ISO 10303 specifies the integrated resources necessary to describe the information requirements identified by ISO 14649 in a manner consistent with the part shape, feature, geometric dimension and tolerance information created by design and process-planning activities and represented by ISO 10303-203 [4], ISO 10303-214 [5], ISO 10303-224 [8], and ISO 10303-240 [9]. It is advisable that users of this part of ISO 10303 understand the basic principles and concepts of numerical controlled machining and associated processes and understand and have access to ISO 14649, particularly ISO 14649-1, ISO 14649-10, ISO 14649-11, ISO 14649-12, ISO 14649-111, and ISO 14649-121. A discussion and data planning model is given in ISO 14649-1.

This application protocol defines the context, scope, and information requirements for numerical controlled machining and associated processes and specifies the integrated resources necessary to satisfy these requirements.

Application protocols provide the basis for developing implementations of ISO 10303 and abstract test suites for the conformance testing of AP implementations.

Clause 1 defines the scope of the application protocol and summarizes the functionality and data covered by the AP. Clause 3 lists the words defined in this part of ISO 10303 and gives pointers to words defined elsewhere. An application activity model that is the basis for the definition of the scope is provided in Annex F. The information requirements of the application are specified in clause 4 using terminology appropriate to the application. A graphical representation of the information requirements, referred to as the application reference model, is given in Annex G.

Resource constructs are interpreted to meet the information requirements. This interpretation produces the application interpreted model (AIM). This interpretation, given in 5.1, shows the correspondence between the information requirements and the AIM. The short listing of the AIM specifies the interface to the integrated resources and is given in 5.2. Note that the definitions and EXPRESS provided in the integrated resources for constructs used in the AIM can include select list items and subtypes which are not imported into the AIM. The expanded listing given in Annex A contains the complete EXPRESS

for the AIM without annotation. A listing of the EXPRESS entity names and corresponding short names is given in Annex B. Information object identifiers for the AIM is given in Annex E. A graphical representation of the AIM is given in Annex H. Additional requirements for specific implementation methods are given in Annex C. A reference to computer interpretable listings of the AIM and EXPRESS entity short names is given in Annex I.

**Warning:**

This part of ISO 10303 provides a specification intended to be implemented in software. Incompatibilities may result in machine-to-machine communication in the case of software developed on the basis of translations of this part of ISO 10303 into languages other than the official ISO languages. It is accordingly strongly recommended that any implementations be developed only on the basis of the texts in the official ISO languages.





# Industrial automation systems and integration — Product data representation and exchange —

Part 238:

## Application protocol: Application interpreted model for computerized numerical controllers

### 1 Scope

This part of ISO 10303 specifies the use of the integrated resources necessary for the scope and information requirements for manufacturing using numerical controlled machining and associated processes, including the scope and information requirements defined by the ISO 14649 data model for computerized numerical controllers.

NOTE 1 The application activity model in Annex F provides a graphical representation of the processes and information flows that are the basis for the definition of the scope of this part of ISO 10303.

NOTE 2 This part of ISO 10303 is a member of the “STEP Manufacturing Suite” of ISO 10303 application protocols, which cover a wide range of information associated with the manufacture of a product, such as the input to process planning (ISO 10303-224 [8]), the output from macro-process planning (ISO 10303-240 [9]), numerically-controlled machining (this part of ISO 10303), casting (ISO 10303-223 [7]) and the output from dimensional inspection (ISO 10303-219 [6]). While each application protocol has unique scope elements, other elements, such as manufacturing feature and manufacturing tolerance descriptions, are common to many of these application protocols.

The following are within the scope of this part of ISO 10303:

- mechanical parts for manufacturing;
- manufacturing process descriptions, including manufacturing operations, sequences of operations, and associated information as defined in ISO 14649;

NOTE 3 The ISO 14649 documents available at the time of publication cover milling, drilling, and turning processes (ISO 14649-11 and ISO 14649-12). Future editions of this part of ISO 10303 might include additional numerically-controlled processes if additional ISO 14649 descriptions become available.

- the AS-IS and TO-BE shapes of a mechanical part;
- manufacturing features of a part;
- manufacturing tolerance requirements of a part;

ISO 10303-238:2007(E)

- tool requirements for machining operations;
- tool paths for machining operations;
- manufacture of mechanical products using manufacturing processes defined in ISO 14649;
- manufacturing product discipline view.

The following are outside the scope of this part of ISO 10303:

- composite material parts;
- description of manufacturing activities not related to automatic execution by a computerized numerical controller;

NOTE 4 This includes activities such as factory capacity planning and scheduling.

- a catalogue of machines available on a factory floor;
- a catalogue of tools available in a machine tool magazine;
- design features of a part;
- manufacturing preplanning activities;
- product discipline views other than manufacturing.

## 2 Normative references

The following referenced documents are indispensable for the application of this document. For dated references, only the edition cited applies. For undated references, the latest edition of the referenced document (including any amendments) applies.

ISO 286-1:1988, *ISO system of limits and fits — Part 1: Bases of tolerances, deviations and fits*

ISO 286-2:1988, *ISO system of limits and fits — Part 2: Tables of standard tolerance grades and limit deviations for holes and shafts*

ISO 1101:2004, *Geometrical Product Specifications (GPS) — Geometrical tolerancing — Tolerances of form, orientation, location and run-out*

ISO 2806:1994, *Industrial automation systems and integration — Numerical control of machines — Vocabulary*

ISO 5459:1981, *Technical drawings — Geometric tolerancing — Datums and datum-systems for geometrical tolerances*

ISO/IEC 8824-1:2002, *Information technology — Abstract Syntax Notation One (ASN.1) — Part 1: Specification of basic notation*

ISO 10303-1:1994, *Industrial automation systems and integration — Product data representation and exchange — Part 1: Overview and fundamental principles*

ISO 10303-11:1994, *Industrial automation systems and integration — Product data representation and exchange — Part 11: Description methods: The EXPRESS language reference manual*

ISO 10303-21:2002, *Industrial automation systems and integration — Product data representation and exchange — Part 21: Implementation methods: Clear text encoding of the exchange structure*

ISO 10303-28:—<sup>1)</sup>, *Industrial automation systems and integration — Product data representation and exchange — Part 28: Implementation methods: XML representations of EXPRESS schemas and data*

ISO 10303-41:2005, *Industrial automation systems and integration — Product data representation and exchange — Part 41: Integrated generic resource: Fundamentals of product description and support*

ISO 10303-42:2003, *Industrial automation systems and integration — Product data representation and exchange — Part 42: Integrated generic resource: Geometric and topological representation*

ISO 10303-43:2000, *Industrial automation systems and integration — Product data representation and exchange — Part 43: Integrated generic resource: Representation structures*

ISO 10303-44:2000, *Industrial automation systems and integration — Product data representation and exchange — Part 44: Integrated generic resource: Product structure configuration*

ISO 10303-45:1998, *Industrial automation systems and integration — Product data representation and exchange — Part 45: Integrated generic resource: Materials*

ISO 10303-47:1997, *Industrial automation systems and integration — Product data representation and exchange — Part 47: Integrated generic resource: Shape variation tolerances*

ISO 10303-49:1998, *Industrial automation systems and integration — Product data representation and exchange — Part 49: Integrated generic resource: Process structure and properties*

ISO 10303-501:2000, *Industrial automation systems and integration — Product data representation and exchange — Part 501: Application interpreted construct: Edge-based wireframe*

ISO 10303-502:2000, *Industrial automation systems and integration — Product data representation and exchange — Part 502: Application interpreted construct: Shell-based wireframe*

ISO 10303-507:2001, *Industrial automation systems and integration — Product data representation and exchange — Part 507: Application interpreted construct: Geometrically bounded surface*

ISO 10303-508:2001, *Industrial automation systems and integration — Product data representation and exchange — Part 508: Application interpreted construct: Non-manifold surface*

---

1) To be published. (Revision of ISO 10303-28:2003)

ISO 10303-238:2007(E)

ISO 10303-509:2001, *Industrial automation systems and integration — Product data representation and exchange — Part 509: Application interpreted construct: Manifold surface*

ISO 10303-510:2000, *Industrial automation systems and integration — Product data representation and exchange — Part 510: Application interpreted construct: Geometrically bounded wireframe*

ISO 10303-511:2001, *Industrial automation systems and integration — Product data representation and exchange — Part 511: Application interpreted construct: Topologically bounded surface*

ISO 10303-512:1999, *Industrial automation systems and integration — Product data representation and exchange — Part 512: Application interpreted construct: Faceted boundary representation*

ISO 10303-514:1999, *Industrial automation systems and integration — Product data representation and exchange — Part 514: Application interpreted construct: Advanced boundary representation*

ISO 10303-519:2000, *Industrial automation systems and integration — Product data representation and exchange — Part 519: Application interpreted construct: Geometric tolerances*

ISO 10303-522:2006, *Industrial automation systems and integration — Product data representation and exchange — Part 522: Application interpreted construct: Machining features*

ISO 13584-20:1998, *Industrial automation systems and integration — Parts library — Part 20: Logical resource: Logical model of expressions*

ISO 14649-1:2003, *Industrial automation systems and integration — Physical device control — Data model for computerized numerical controllers — Part 1: Overview and fundamental principles*

ISO 14649-10:2004, *Industrial automation systems and integration — Physical device control — Data model for computerized numerical controllers — Part 10: General process data*

ISO 14649-11:2004, *Industrial automation systems and integration — Physical device control — Data model for computerized numerical controllers — Part 11: Process data for milling*

ISO 14649-12:2005, *Industrial automation systems and integration — Physical device control — Data model for computerized numerical controllers — Part 12: Process data for turning*

ISO 14649-111:—<sup>1)</sup>, *Industrial automation systems and integration — Physical device control — Data model for computerized numerical controllers — Part 111: Tools for milling*

ISO 14649-121:2005, *Industrial automation systems and integration — Physical device control — Data model for computerized numerical controllers — Part 121: Tools for turning machines*

---

1) To be published.

### **3 Terms and definitions**

#### **3.1 Terms defined in ISO 1101**

For the purposes of this document, the following terms defined in ISO 1101 apply.

- dimension;
- tolerance.

#### **3.2 Terms defined in ISO 2806**

For the purposes of this document, the following terms defined in ISO 2806 apply.

- computerized numerical control (CNC);
- numerical control (NC);
- tool path.

#### **3.3 Terms defined in ISO 5459**

For the purposes of this document, the following terms defined in ISO 5459 apply.

- datum.

#### **3.4 Terms defined in ISO 10303-1**

For the purposes of this document, the following terms defined in ISO 10303-1 apply.

- application;
- application activity model (AAM);
- application interpreted model (AIM);
- application object;
- application protocol (AP);
- application reference model (ARM);
- conformance testing;
- implementation method;
- integrated resource;

ISO 10303-238:2007(E)

- protocol implementation conformance statement (PICS);
- product;
- product data;
- unit of functionality (UoF).

### **3.5 Terms defined in ISO 10303-11**

For the purposes of this document, the following terms defined in ISO 10303-11 apply.

- complex entity instance;
- simple entity instance.

### **3.6 Terms defined in ISO 14649-1**

For the purposes of this document, the following terms defined in ISO 14649-1 apply.

- executable;
- machining operation;
- NC function;
- program structure;
- project;
- workingstep;
- workplan.

### **3.7 Terms defined in ISO 14649-10**

For the purposes of this document, the following terms defined in ISO 14649-10 apply.

- freeform machining.

### **3.8 Terms defined in ISO 14649-11**

For the purposes of this document, the following terms defined in ISO 14649-11 apply.

- finishing;
- roughing.

## 4 Information requirements

This clause specifies the information required for manufacturing using numerical controlled machining and associated processes, including information requirements defined by the ISO 14649 data model for computerized numerical controllers.

The information requirements are specified as a set of units of functionality, application objects, and application assertions. These assertions pertain to individual application objects and to relationships between application objects. The information requirements are defined using the terminology of the subject area of this application protocol.

NOTE 1 A graphical representation of the information requirements is given in Annex G.

NOTE 2 The information requirements correspond to those of the activities identified as being within the scope of this application protocol in Annex F.

NOTE 3 The mapping table specified in 5.1 shows how the integrated resources and application interpreted constructs are used to meet the information requirements of this application protocol.

### 4.1 Units of functionality

This subclause specifies the units of functionality for the computerized numerical controllers application protocol. This part of ISO 10303 specifies the following units of functionality:

- measure;
- project;
- workpiece;
- manufacturing feature;
- executable;
- toolpath;
- process data for milling;
- cutting tools for milling;
- manufacturing feature for turning;
- process data for turning;
- cutting tools for turning;
- geometric dimensioning and tolerancing;

ISO 10303-238:2007(E)

- library reference;
- management.

The units of functionality and a description of the functions that each UoF supports are given below. The application objects included in the UoFs are defined in either 4.2 or ISO 14649, as indicated below.

### 4.1.1 measure

The measure UoF specifies the representation of physical quantities by its value and its unit, along with the representation of allowable variation in that quantity.

The following application objects are used by the measure UoF. These application objects are defined by clause 4.2 of ISO 14649-10:2004 but are extended by this part of ISO 10303 with additional information requirements beyond those specified by ISO 14649-10:

NOTE As defined in ISO 14649-10, these measurements do not explicitly specify a unit. Instead, a default unit is defined for each quantity (mm for length, degrees for angles, etc). In addition, only length parameters could be qualified with a tolerance. This part of ISO 10303 extends these definitions to allow units to be explicitly specified, allows tolerances for any of the measure types, and adds a maximum/minimum Limit\_qualifier to the types of qualifications available. The measure types below are all redefined to be a subtype of either Value\_with\_unit or Value\_with\_tolerance.

- Length\_measure;
- Limits\_and\_fits;
- Plane\_angle\_measure;
- Plus\_minus\_value;
- Pressure\_measure;
- Rot\_speed\_measure;
- Speed\_measure;
- Time\_measure;
- Toleranced\_length\_measure.

In addition, the following application objects are used by the measure UoF, and are defined by this part of ISO 10303:

- Area\_measure;
- Limit\_qualifier;



- Mass\_measure;
- Value\_range;
- Value\_with\_tolerance;
- Value\_with\_unit;
- Volume\_measure.

### 4.1.2 project

The project UoF specifies where to begin interpretation of a machining program, as well as additional management information about the machining program.

The following application objects are used by the project UoF, and are defined by clause 4.3 of ISO 14649-10:2004:

- Project;
- Person\_and\_address.

NOTE The definition of project in ISO 14649-10 references the “approval” integrated resource entity from ISO 10303-41. This reference does not completely define the information requirements for approvals, so the Approval application object and other associated objects have been defined in the management UoF.

### 4.1.3 workpiece

The workpiece UoF specifies the mechanical product that is to be produced by a machining program. This description may include material, surface condition, features, and the AS-IS and TO-BE shape of the product.

The following application objects are used by the workpiece UoF, and are defined by clause 4.4 of ISO 14649-10:2004.

- Descriptive\_parameter;
- Manufacturing\_feature;
- Material;
- Numeric\_parameter;
- Property\_parameter;
- Workpiece.

ISO 10303-238:2007(E)

This part of ISO 10303 extends the following application objects with additional information requirements beyond those specified by clause 4.4 of ISO 14649-10:2004.

- Manufacturing\_feature;
- Workpiece.

In addition, the following application objects are used by the workpiece UoF, and are defined by this part of ISO 10303:

- General\_property;
- Hardness;
- Material\_property;
- Part\_property;
- Process\_property;
- Surface\_property;
- Workpiece\_assembly\_component.

#### **4.1.4 manufacturing feature**

The manufacturing feature UoF specifies the information necessary to identify shapes of interest on a mechanical product. These shapes represent volumes of material that are removed by machining operations or which result from a series of machining operations. This UoF also specifies the information necessary to describe a feature using a 2D profile swept along a path, as well as information describing the top, bottom, and other boundaries of a feature.

The following application objects are used by the manufacturing feature UoF, and are defined by clause 4.5 of ISO 14649-10:2004.

- Angle\_taper;
- Blind\_bottom\_condition;
- Boss;
- Catalogue\_thread;
- Chamfer;
- Circular\_closed\_profile;
- Circular\_closed\_shape\_profile;

- Circular\_offset;
- Circular\_omit;
- Circular\_path;
- Circular\_pattern;
- Closed\_pocket;
- Closed\_profile;
- Complete\_circular\_path;
- Compound\_feature;
- Conical\_hole\_bottom;
- Counterbore\_hole;
- Countersunk\_hole;
- Defined\_thread;
- Diameter\_taper;
- Edge\_round;
- Flat\_hole\_bottom;
- Flat\_slot\_end\_type;
- Flat\_with\_radius\_hole\_bottom;
- General\_closed\_profile;
- General\_outside\_profile;
- General\_path;
- General\_pattern;
- General\_pocket\_bottom\_condition;
- General\_profile;
- General\_profile\_floor;
- General\_shape\_profile;

- Hole\_bottom\_condition;
- Linear\_path;
- Linear\_profile;
- Loop\_slot\_end\_type;
- Machined\_surface;
- Machining\_feature;
- Ngon\_profile;
- Open\_pocket;
- Open\_profile;
- Open\_slot\_end\_type;
- Partial\_area\_definition;
- Partial\_circular\_path;
- Partial\_circular\_profile;
- Partial\_circular\_shape\_profile;
- Planar\_face;
- Planar\_pocket\_bottom\_condition;
- Planar\_profile\_floor;
- Pocket;
- Pocket\_bottom\_condition;
- Profile;
- Profile\_feature;
- Profile\_floor;
- Radiused\_pocket\_bottom\_condition;
- Radiused\_slot\_end\_type;
- Rectangular\_closed\_profile;

- Rectangular\_closed\_shape\_profile;
- Rectangular\_offset;
- Rectangular\_omit;
- Rectangular\_open\_shape\_profile;
- Rectangular\_pattern;
- Region;
- Region\_projection;
- Region\_surface\_list;
- Replicate\_feature;
- Round\_hole;
- Rounded\_end;
- Rounded\_u\_profile;
- Shape\_profile;
- Slot;
- Slot\_end\_type;
- Specification;
- Specification\_usage\_constraint;
- Spherical\_cap;
- Spherical\_hole\_bottom;
- Square\_u\_profile;
- Step;
- Surface\_texture\_parameter;
- Tee\_profile;
- Thread;
- Through\_bottom\_condition;

ISO 10303-238:2007(E)

- Through\_pocket\_bottom\_condition;
- Through\_profile\_floor;
- Toolpath\_feature;
- Topological\_region;
- Transition\_feature;
- Travel\_path;
- Two5d\_manufacturing\_feature;
- Vee\_profile;
- Woodruff\_slot\_end\_type.

This part of ISO 10303 extends the following application objects with additional information requirements beyond those specified by clause 4.5 of ISO 14649-10:2004.

- Boss;
- Chamfer;
- Edge\_round;
- General\_closed\_profile;
- General\_path;
- General\_profile;
- Machining\_feature;
- Planar\_face;
- Pocket;
- Round\_hole;
- Rounded\_u\_profile;
- Square\_u\_profile;
- Transition\_feature;
- Vee\_profile.

### 4.1.5 executable

The executable UoF specifies the information necessary to describe control flow of a machining program as well as the non-machining actions that may be performed by a numerical control. This includes sequential, parallel, and conditional control flow, as well as the logical expressions and variable elements necessary to describe the conditions for conditional control flow. This UoF also specifies the information necessary to describe how a mechanical product, products, or multiple copies thereof are positioned and orientated relative to any machine tool on which a machining program is to be executed.

The following application objects are used by the executable UoF, and are defined by clause 4.6 of ISO 14649-10:2004.

- And\_expression;
- Assignment;
- Binary\_boolean\_expression;
- Boolean\_expression;
- Channel;
- Comparison\_equal;
- Comparison\_expression;
- Comparison\_greater;
- Comparison\_greater\_equal;
- Comparison\_less;
- Comparison\_less\_equal;
- Comparison\_not\_equal;
- Display\_message;
- Executable;
- If\_statement;
- In\_process\_geometry;
- Machining\_tool;
- Machining\_workingstep;

- Multiple\_arity\_boolean\_expression;
- NC\_constant;
- NC\_function;
- NC\_variable;
- Non\_sequential;
- Not\_expression;
- Offset\_vector;
- Optional\_stop;
- Or\_expression;
- Parallel;
- Program\_stop;
- Program\_structure;
- Rapid\_movement;
- Return\_home;
- Selective;
- Set\_mark;
- Setup;
- Setup\_instruction;
- Tool\_length\_probing;
- Tool\_probing;
- Tool\_radius\_probing;
- Touch\_probe;
- Touch\_probing;
- Unary\_boolean\_expression;
- Wait\_for\_mark;



- While\_statement;
- Workingstep;
- Workpiece\_complete\_probing;
- Workpiece\_probing;
- Workpiece\_setup;
- Workplan;
- Xor\_expression.

This part of ISO 10303 extends the following application objects with additional information requirements beyond those specified by clause 4.6 of ISO 14649-10:2004.

- In\_process\_geometry;
- Machining\_workingstep;
- Workplan.

In addition, the following application objects are used by the executable UoF, and are defined by this part of ISO 10303:

- Extended\_NC\_function;
- Machine\_axis\_travel;
- Machine\_parameters;
- Tool\_usage.

#### **4.1.6 operation**

The operation UoF specifies the information necessary to describe the technology-independent aspects of machining actions that may be performed by a numerical control.

NOTE This UoF only describes the basic aspects common to all machining actions. The technology-specific aspects of machining actions such as milling, drilling, turning, and knurling are described by the process data for milling UoF (see 4.1.8) and process data for turning UoF (see 4.1.11).

The following application objects are used by the operation UoF, and are defined by clause 4.7 of ISO 14649-10:2004.

- Machine\_functions;
- Machining\_operation;

ISO 10303-238:2007(E)

- Operation;
- Technology;
- Three\_axes;
- Tool\_direction;
- Toolpath\_list;
- Two\_axes.

### **4.1.7 toolpath**

The toolpath UoF specifies the information necessary to describe the motion of a cutting tool as either a precalculated movement trajectory or as a set of motion parameters that can be converted to an exact movement by a numerical control. This includes the information necessary to describe movement trajectories relative to the tip of the cutting tool, the contact point of the cutting tool, or an axis of a machine, as well as to describe the path and rate of movement using splines and other curves.

The following application objects are used by the toolpath UoF, and are defined by clause 4.8 of ISO 14649-10:2004.

- Ap\_lift\_path\_angle;
- Ap\_lift\_path\_tangent;
- Approach\_lift\_path;
- Axis\_trajectory;
- Connect\_direct;
- Connect\_secplane;
- Connector;
- Curve\_with\_normal\_vector;
- Cutter\_contact\_trajectory;
- Cutter\_location\_trajectory;
- Feedstop;
- Parameterised\_path;
- Toolpath;

- Toolpath\_speed;
- Trajectory.

This part of ISO 10303 extends the following application objects with additional information requirements beyond those specified by clause 4.8 of ISO 14649-10:2004.

- Cutter\_contact\_trajectory;
- Cutter\_location\_trajectory;
- Toolpath;
- Toolpath\_speed.

#### 4.1.8 process data for milling

The process data for milling UoF specifies the information necessary to describe the milling and drilling-specific aspects of machining actions that may be performed by a numerical control. This includes the information necessary to describe strategies and process parameters for milling and drilling.

The following application objects are used by the process data for milling UoF, and are defined by clause 4 of ISO 14649-11:2004.

- Adaptive\_control;
- Air\_strategy;
- Along\_path;
- Ap\_retract\_angle;
- Ap\_retract\_tangent;
- Approach\_retract\_strategy;
- Back\_boring;
- Bidirectional;
- Bidirectional\_contour;
- Boring;
- Boring\_operation;
- Bottom\_and\_side\_finish\_milling;
- Bottom\_and\_side\_milling;

ISO 10303-238:2007(E)

- Bottom\_and\_side\_rough\_milling;
- Center\_drilling;
- Center\_milling;
- Contour\_bidirectional;
- Contour\_parallel;
- Contour\_spiral;
- Counter\_sinking;
- Drilling;
- Drilling\_operation;
- Drilling\_type\_operation;
- Drilling\_type\_strategy;
- Exchange\_pallet;
- Explicit\_strategy;
- Five\_axes\_const\_tilt\_yaw;
- Five\_axes\_var\_tilt\_yaw;
- Freeform\_operation;
- Freeform\_strategy;
- Index\_pallet;
- Index\_table;
- Leading\_line\_strategy;
- Load\_tool;
- Milling\_machine\_functions;
- Milling\_machining\_operation;
- Milling\_technology;
- Milling\_type\_operation;

- Multistep\_drilling;
- Plane\_cc\_strategy;
- Plane\_cl\_strategy;
- Plane\_finish\_milling;
- Plane\_milling;
- Plane\_rough\_milling;
- Plunge\_helix;
- Plunge\_ramp;
- Plunge\_strategy;
- Plunge\_toolaxis;
- Plunge\_zigzag;
- Process\_model;
- Process\_model\_list;
- Reaming;
- Side\_finish\_milling;
- Side\_milling;
- Side\_rough\_milling;
- Tapping;
- Thread\_drilling;
- Three\_axes\_tilted\_tool;
- Tolerances;
- Tool\_direction\_for\_milling;
- Two5d\_milling\_operation;
- Two5d\_milling\_strategy;
- Unidirectional;

ISO 10303-238:2007(E)

- Unload\_tool;
- Uv\_strategy.

This part of ISO 10303 extends the following application objects with additional information requirements beyond those specified by clause 4 of ISO 14649-11:2004.

- Milling\_machine\_functions.

In addition, the following application objects are used by the process data for milling UoF, and are defined by this part of ISO 10303:

- Freeform\_finish\_milling;
- Freeform\_rough\_milling;
- Machine\_axis\_constraint.

#### **4.1.9 cutting tools for milling**

The cutting tools for milling UoF specifies the information necessary to describe the milling and drilling-specific tool requirements for machining actions.

The following application objects are used by the cutting tools for milling UoF, and are defined by clause 4 of ISO 14649-11:—.

- Ballnose\_endmill;
- Bullnose\_endmill;
- Combined\_drill\_and\_reamer;
- Combined\_drill\_and\_tap;
- Counterbore;
- Countersink;
- Cutting\_component;
- Dovetail\_mill;
- Drilling\_cutting\_tool;
- Endmill;
- Facemill;
- Milling\_cutting\_tool;

- Milling\_machine\_cutting\_tool;
- Profiled\_end\_mill;
- Reaming\_cutting\_tool;
- Rotating\_boring\_cutting\_tool;
- Shouldermill;
- Side\_mill;
- Spade\_drill;
- Spotdrill;
- Step\_drill;
- T\_slot\_mill;
- Tapered\_drill;
- Tapered\_reamer;
- Tapping\_cutting\_tool;
- Thread\_mill;
- Twist\_drill.

In addition, the following application objects are used by the cutting tools for milling UoF, and are defined by this part of ISO 10303:

- User\_defined\_milling\_tool.

#### **4.1.10 turning feature**

The turning feature UoF specifies the information necessary to identify shapes of interest on a mechanical product. These shapes represent volumes of material that are commonly removed by turning operations or which result from a series of turning operations.

NOTE Turning features also result from milling, drilling, or other operations, but are described using parameters that are particularly relevant to turning operations.

The following application objects are used by the turning feature UoF, and are defined by clause 4.2 of ISO 14649-12:2005.

- Diagonal\_knurl;

ISO 10303-238:2007(E)

- Diamond\_knurl;
- General\_revolution;
- Groove;
- Knurl;
- Outer\_diameter;
- Outer\_diameter\_to\_shoulder;
- Outer\_round;
- Revolved\_feature;
- Revolved\_flat;
- Revolved\_round;
- Straight\_knurl;
- Tool\_knurl;
- Turning\_feature.

#### **4.1.11 process data for turning**

The process data for turning UoF specifies the information necessary to describe the turning-specific aspects of machining actions that may be performed by a numerical control. This includes the information necessary to describe strategies and process parameters for turning.

The following application objects are used by the process data for turning UoF, and are defined by clauses 4.3 and 4.4 of ISO 14649-12:2005.

- Bidirectional\_turning;
- Const\_cutting\_speed;
- Const\_spindle\_speed;
- Contour\_turning;
- Contouring;
- Contouring\_finish;
- Contouring\_rough;



- Cutting\_in;
- Explicit\_turning\_strategy;
- Facing;
- Facing\_finish;
- Facing\_rough;
- Grooving;
- Grooving\_finish;
- Grooving\_rough;
- Grooving\_strategy;
- Knurling;
- Multistep\_grooving\_strategy;
- Thread\_strategy;
- Threading;
- Threading\_finish;
- Threading\_rough;
- Turning\_machine\_functions;
- Turning\_machining\_operation;
- Turning\_machining\_strategy;
- Turning\_technology;
- Turning\_workingstep;
- Unidirectional\_turning.

#### **4.1.12 cutting tools for turning**

The cutting tools for turning UoF specifies the information necessary to describe the turning-specific tool requirements for machining actions.

The following application objects are used by the cutting tools for turning UoF, and are defined by clause 4 of ISO 14649-121:2005.

ISO 10303-238:2007(E)

- Chamfered\_corner;
- Corner\_transition;
- Cutting\_edge\_properties;
- General\_turning\_tool;
- Grooving\_tool;
- Knurling\_tool;
- Profiled\_corner;
- Rounded\_corner;
- Turning\_machine\_cutting\_tool;
- Turning\_threading\_tool;
- User\_defined\_turning\_tool.

### 4.1.13 geometric dimensioning and tolerancing

The geometric dimensioning and tolerancing UoF specifies the information necessary to describe geometric dimensions, as well as the allowable variation in those dimensions for the purposes of manufacturing. In addition, this UoF specifies the information necessary to describe geometric tolerances with a datum reference, such as parallelism or perpendicularity, and geometric tolerances without a datum reference, such as straightness or flatness. This includes the information necessary to describe single datum references, common datum references, datum targets, and tolerance zones.

The following application objects are used by the geometric dimensioning and tolerancing UoF:

NOTE The following application objects have been harmonized with the information requirements for geometric dimensions and tolerances defined by ISO 10303-1050 [15] and ISO 10303-1051 [16], which themselves are the result of harmonization efforts between ISO 10303-224 and ISO 10303-214. Application objects dealing with the numerical value of the tolerances (nominal, plus/minus, range, etc.) are addressed in the measure UoF.

- Angular\_location\_dimension;
- Angular\_size\_dimension;
- Angularity\_tolerance;
- Circular\_runout\_tolerance;
- Coaxiality\_tolerance;
- Common\_datum;

- Concentricity\_tolerance;
- Curved\_distance\_dimension;
- Curved\_size\_dimension;
- Cylindricity\_tolerance;
- Datum;
- Datum\_defined\_by\_derived\_shape;
- Datum\_defined\_by\_feature;
- Datum\_defined\_by\_targets;
- Datum\_reference;
- Datum\_target;
- Diameter\_size\_dimension;
- Externally\_defined\_size\_dimension;
- Flatness\_tolerance;
- Geometric\_dimension;
- Geometric\_tolerance;
- Geometric\_tolerance\_relationship;
- Height\_size\_dimension;
- Length\_size\_dimension;
- Line\_profile\_tolerance;
- Linear\_distance\_dimension;
- Location\_dimension;
- Measurement\_path;
- Parallelism\_tolerance;
- Perpendicularity\_tolerance;
- Placed\_target;

ISO 10303-238:2007(E)

- Position\_tolerance;
- Projection;
- Radial\_size\_dimension;
- Roundness\_tolerance;
- Single\_datum;
- Size\_dimension;
- Straightness\_tolerance;
- Surface\_profile\_tolerance;
- Symmetry\_tolerance;
- Target\_area;
- Target\_circle;
- Target\_point;
- Target\_rectangle;
- Target\_straight\_line;
- Thickness\_size\_dimension;
- Tolerance\_condition;
- Tolerance\_zone;
- Tolerance\_zone\_definition;
- Total\_runout\_tolerance;
- Width\_size\_dimension.

#### **4.1.14 library reference**

The library reference UoF provides the capability and mechanisms by which references can be made to information in external libraries.

The following application objects are used by the library reference UoF:

NOTE The following application objects have been harmonized with the information requirements for library reference UoF defined by ISO 10303-240 [9].

- BSU;
- Class\_BSU;
- Externally\_defined\_representation;
- Library\_part\_assignment;
- Library\_property\_value;
- Property\_BSU;
- Supplier\_BSU.

### 4.1.15 management

The management UoF specifies the information necessary to describe the management aspects of a mechanical product or machining program. This includes the information necessary to describe the approval process, security classifications, persons and dates.

The following application objects are used by the management UoF:

NOTE The following four Approval application objects have been harmonized with the information requirements for approvals defined by ISO 10303-1012 [10].

- Approval;
- Approval\_relationship;
- Approval\_status;
- Approving\_person\_organization;
- Assigned\_date;
- Assigned\_organization;
- Assigned\_person;
- Assigned\_time;
- Last\_modified\_timestamp;

NOTE The following two Security\_classification application objects have been harmonized with the information requirements for security classifications defined by ISO 10303-1015 [13].

- Security\_classification;

— Security\_classification\_assignment.

## 4.2 Application objects

This subclause specifies the application objects for the computerized numerical controllers application protocol. Each application object is an atomic element that embodies a unique application concept and contains attributes specifying the data elements of the object. The application objects and their definitions are given below.

NOTE For application objects defined by ISO 14649, a normative reference to the originating document is provided, as well as an informative note containing the ISO 14649 EXPRESS description. Full definitions are provided for all objects not defined in the ISO 14649 documents as well as extensions to the application objects defined in the ISO 14649 documents.

### 4.2.1 Adaptive\_control

The Adaptive\_control application object is defined by clause 4 of ISO 14649-11:2004.

NOTE The ISO 14649 EXPRESS description for Adaptive\_control is shown below. Refer to ISO 14649-11 for the complete definition and explanation of usage.

```
ENTITY adaptive_control;  
END_ENTITY;
```

### 4.2.2 Air\_strategy

The Air\_strategy application object is defined by clause 4 of ISO 14649-11:2004.

NOTE The ISO 14649 EXPRESS description for Air\_strategy is shown below. Refer to ISO 14649-11 for the complete definition and explanation of usage.

```
ENTITY air_strategy  
ABSTRACT SUPERTYPE OF (ONEOF (ap_retract_angle, ap_retract_tangent))  
SUBTYPE OF (approach_retract_strategy);  
END_ENTITY;
```

### 4.2.3 Along\_path

The Along\_path application object is defined by clause 4 of ISO 14649-11:2004.

NOTE The ISO 14649 EXPRESS description for Along\_path is shown below. Refer to ISO 14649-11 for the complete definition and explanation of usage.

```
ENTITY along_path  
SUBTYPE OF (approach_retract_strategy);  
path: toolpath_list;  
END_ENTITY;
```

## 4.2.4 And\_expression

The And\_expression application object is defined by clause 4.6 of ISO 14649-10:2004.

NOTE The ISO 14649 EXPRESS description for And\_expression is shown below. Refer to ISO 14649-10 for the complete definition and explanation of usage.

```
ENTITY and_expression
  SUBTYPE OF (multiple_arity_boolean_expression);
END_ENTITY;
```

## 4.2.5 Angle\_taper

The Angle\_taper application object is defined by clause 4.5 of ISO 14649-10:2004.

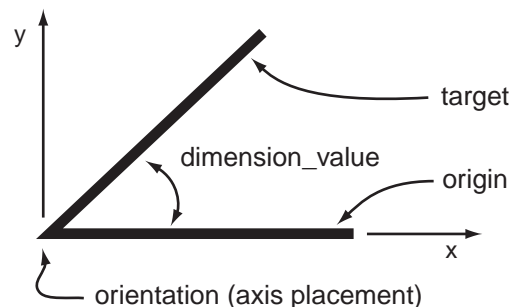
NOTE The ISO 14649 EXPRESS description for Angle\_taper is shown below. Refer to ISO 14649-10 for the complete definition and explanation of usage.

```
ENTITY angle_taper;
  angle: plane_angle_measure;
END_ENTITY;
```

## 4.2.6 Angular\_location\_dimension

An Angular\_location\_dimension is a type of Location\_dimension (see 4.2.187) that defines the allowable variation in the angle between two elements of the shape of a part.

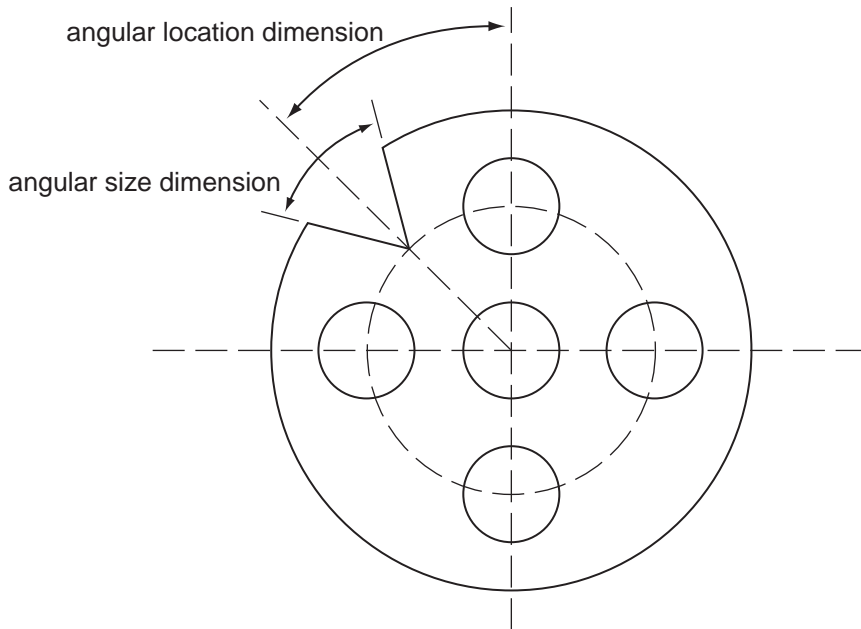
NOTE This definition has been harmonized with the Angular\_location\_dimension definitions in ISO 10303-1050 and ISO 10303-214, as well as the Angular\_dimension\_tolerance definition in ISO 10303-224. Figure 1 illustrates an Angular\_location\_dimension. Figure 2 illustrates the difference between an Angular\_location\_dimension and an Angular\_size\_dimension (see 4.2.7).



**Figure 1 — Angular\_location\_dimension**

The data associated with an Angular\_location\_dimension are the following:

- orientation.



**Figure 2 — Angular\_location\_dimension versus Angular\_size\_dimension**

#### 4.2.6.1 orientation

The orientation specifies an axis placement establishing the direction of positive measure of the Angular\_location\_dimension. The angle extends in the XY plane from the X axis towards Y, about the origin.

#### 4.2.7 Angular\_size\_dimension

An Angular\_size\_dimension is a type of Size\_dimension (see 4.2.313) that defines the allowable variation in the angular size of an element of the shape of a part.

NOTE This definition has been harmonized with the Angular\_size\_dimension definitions in ISO 10303-1050 and ISO 10303-214, as well as the Angular\_size\_dimension\_tolerance definition in ISO 10303-224. Figure 3 illustrates the parameter combinations of an Angular\_size\_dimension.

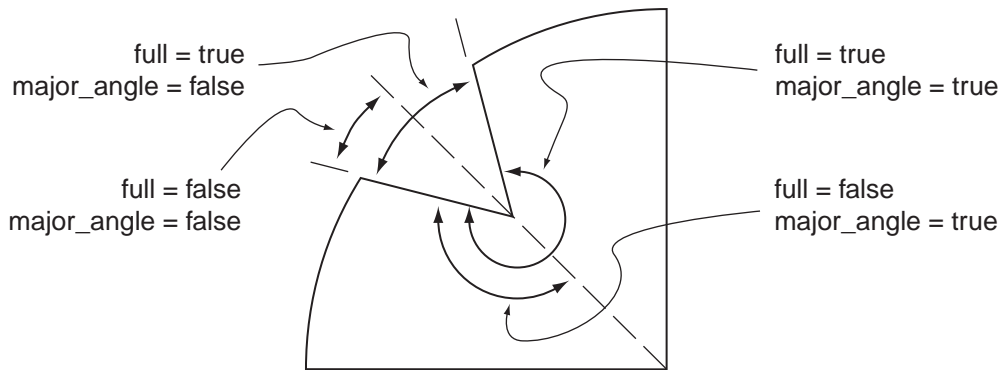
The data associated with an Angular\_size\_dimension are the following:

- full;
- major\_angle.

##### 4.2.7.1 full

The full attribute specifies whether the Angular\_size\_dimension refers to the full angle or the half angle representing the size of the shape element.





**Figure 3 — Angular\_size\_dimension**

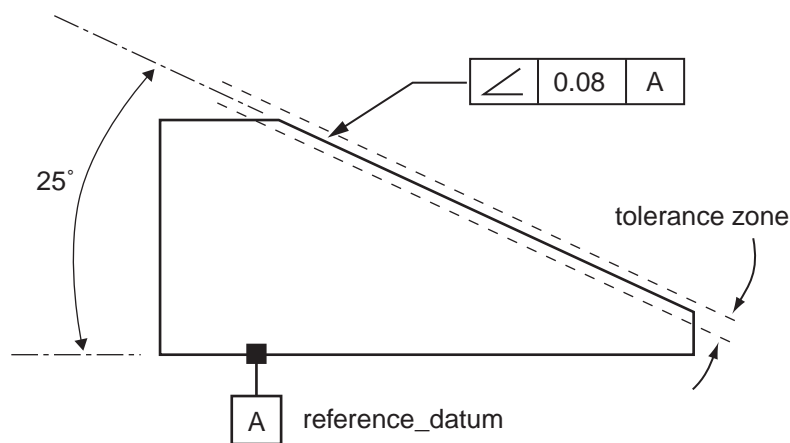
### 4.2.7.2 major\_angle

The major\_angle specifies which of the two possible angles shall be considered. A value of ‘true’ specifies the angle to be the larger of the two angles formed by the angular element.

### 4.2.8 Angularity\_tolerance

An Angularity\_tolerance is a type of Geometric\_tolerance (see 4.2.156) that specifies a constraint on the location of a surface, of a centre plane, of an edge, or of an axis that lies theoretically at a specified angle (other than 90 degrees) from a datum plane or from a datum axis. An Angularity\_tolerance specifies one of the following:

NOTE This definition has been harmonized with the Angularity\_tolerance definitions in ISO 10303-1051, ISO 10303-214, and ISO 10303-224. This definition is derived from clause 14.9 of ISO 1101:2004. Figure 4 illustrates an Angularity\_tolerance for a plane surface.



**Figure 4 — Angularity\_tolerance**

- a tolerance zone defined by two parallel planes at the specified basic angle from a datum plane or axis within which the considered element shall lie;
- a tolerance zone defined by a cylinder at the specified basic angle from a datum plane or axis within which the considered element shall lie.

The data associated with an `Angularity_tolerance` are the following:

- `reference_datum`.

#### 4.2.8.1 `reference_datum`

The `reference_datum` specifies the set of `Datum_reference` objects that define the reference frame for the geometric tolerance. See 4.3.1 for the application assertion.

#### 4.2.9 `Ap_lift_path_angle`

The `Ap_lift_path_angle` application object is defined by clause 4.8 of ISO 14649-10:2004.

NOTE The ISO 14649 EXPRESS description for `Ap_lift_path_angle` is shown below. Refer to ISO 14649-10 for the complete definition and explanation of usage.

```
ENTITY ap_lift_path_angle
  SUBTYPE OF (approach_lift_path);
  angle:          plane_angle_measure;
  benddist:      length_measure;
END_ENTITY;
```

#### 4.2.10 `Ap_lift_path_tangent`

The `Ap_lift_path_tangent` application object is defined by clause 4.8 of ISO 14649-10:2004.

NOTE The ISO 14649 EXPRESS description for `Ap_lift_path_tangent` is shown below. Refer to ISO 14649-10 for the complete definition and explanation of usage.

```
ENTITY ap_lift_path_tangent
  SUBTYPE OF (approach_lift_path);
  radius:          length_measure;
END_ENTITY;
```

#### 4.2.11 `Ap_retract_angle`

The `Ap_retract_angle` application object is defined by clause 4 of ISO 14649-11:2004.

NOTE The ISO 14649 EXPRESS description for `Ap_retract_angle` is shown below. Refer to ISO 14649-11 for the complete definition and explanation of usage.

```
ENTITY ap_retract_angle
  SUBTYPE OF (air_strategy);
  angle:          plane_angle_measure;
```

```

    travel_length: length_measure;
END_ENTITY;

```

#### 4.2.12 Ap\_retract\_tangent

The Ap\_retract\_tangent application object is defined by clause 4 of ISO 14649-11:2004.

NOTE The ISO 14649 EXPRESS description for Ap\_retract\_tangent is shown below. Refer to ISO 14649-11 for the complete definition and explanation of usage.

```

ENTITY ap_retract_tangent
  SUBTYPE OF (air_strategy);
  radius: length_measure;
END_ENTITY;

```

#### 4.2.13 Approach\_lift\_path

The Approach\_lift\_path application object is defined by clause 4.8 of ISO 14649-10:2004.

NOTE The ISO 14649 EXPRESS description for Approach\_lift\_path is shown below. Refer to ISO 14649-10 for the complete definition and explanation of usage.

```

ENTITY approach_lift_path
  ABSTRACT SUPERTYPE OF (ONEOF (ap_lift_path_angle, ap_lift_path_tangent))
  SUBTYPE OF (parameterised_path);
  fix_point: cartesian_point;
  fix_point_dir: OPTIONAL direction;
END_ENTITY;

```

#### 4.2.14 Approach\_retract\_strategy

The Approach\_retract\_strategy application object is defined by clause 4 of ISO 14649-11:2004.

NOTE The ISO 14649 EXPRESS description for Approach\_retract\_strategy is shown below. Refer to ISO 14649-11 for the complete definition and explanation of usage.

```

ENTITY approach_retract_strategy
  ABSTRACT SUPERTYPE OF (ONEOF (plunge_strategy, air_strategy, along_path));
  tool_orientation: OPTIONAL direction;
END_ENTITY;

```

#### 4.2.15 Approval

An Approval is a formal confirmation of the quality of some activity or product data.

NOTE This definition has been harmonized with the Approval definition in ISO 10303-1012.

The data associated with an Approval are the following:

— actual\_date;

ISO 10303-238:2007(E)

- planned\_date;
- purpose;
- status.

#### **4.2.15.1 actual\_date**

The actual\_date specifies the point in time when the Approval actually became valid. The actual\_date need not be specified for a particular Approval.

#### **4.2.15.2 planned\_date**

The planned\_date specifies the point in time when the Approval is or was supposed to be performed. The planned\_date need not be specified for a particular Approval.

#### **4.2.15.3 purpose**

The purpose specifies the text that completes the information provided within the status attribute, specifying the reason or goal of the Approval.

EXAMPLE 'released for production' or 'preliminary design completed' are approval purposes.

#### **4.2.15.4 status**

The status specifies the Approval\_status that provides a user interpretable designation of the level of approval. See 4.3.2 for the application assertion.

### **4.2.16 Approval\_relationship**

An Approval\_relationship is a typed association between two instances of Approval.

NOTE This definition has been harmonized with the Approval\_relationship definition in ISO 10303-1012.

The data associated with an Approval\_relationship are the following:

- description;
- related\_approval;
- relating\_approval;
- relation\_type.

### 4.2.16.1 description

The description specifies the text that provides further information about the Approval\_relationship. The description need not be specified for a particular Approval\_relationship.

### 4.2.16.2 related\_approval

The related\_approval specifies one of the Approval objects that is a part of the relationship. If one element of the relationship is dependent of the other, this attribute shall be the dependent one. See 4.3.3 for the application assertion.

### 4.2.16.3 relating\_approval

The relating\_approval specifies one of the Approval objects that is a part of the relationship. See 4.3.4 for the application assertion.

### 4.2.16.4 relation\_type

The relation\_type specifies the text that specifies the meaning of the relationship. Where applicable, the following values shall be used:

- decomposition: The Approval\_relationship defines a relationship where the related Approval is one of the components into which the relating Approval is broken down with no implication of ‘sequence’ or ‘dependency’;
- dependency: The Approval\_relationship defines a relationship where the issuing of the related Approval is dependent on the issuing of the relating Approval;
- precedence: the Approval\_relationship defines a relationship where the related Approval has higher priority than the relating Approval;
- sequence: The Approval\_relationship defines a relationship where the relating Approval shall be completed before the related Approval is given.

NOTE The value ‘dependency’ does not imply the semantics of the values ‘decomposition’ or ‘sequence’.

EXAMPLE 1 The Approval of an assembly may be dependent on the Approval of all of the constituents of the assembly.

EXAMPLE 2 In parallel approval processes of two assemblies, assignment of an Approval on one of the assemblies may depend on an Approval assigned to the second assembly.

## 4.2.17 Approval\_status

An Approval\_status is a particular rank of approval.

NOTE This definition has been harmonized with the Approval\_status definition in ISO 10303-1012.

ISO 10303-238:2007(E)

The data associated with an Approval\_status are the following:

- status\_name.

#### **4.2.17.1 status\_name**

The status\_name specifies the text by which the Approval\_status is designated.

EXAMPLE 'approved' and 'disapproved' are examples of Approval\_status.

#### **4.2.18 Approving\_person\_organization**

An Approving\_person\_organization is an association between an Approval and the organization or person and organization that has granted this approval.

NOTE This definition has been harmonized with the Approving\_person\_organization definition in ISO 10303-1012.

The data associated with an Approving\_person\_organization are the following:

- approval\_date;
- authorized\_approval;
- person\_organization;
- role.

##### **4.2.18.1 approval\_date**

The approval\_date specifies the point in time when the Approval has been given. The approval\_date need not be specified for a particular Approving\_person\_organization.

##### **4.2.18.2 authorized\_approval**

The authorized\_approval specifies the Approval that has been given by the considered person or the organization. See 4.3.5 for the application assertion.

##### **4.2.18.3 person\_organization**

The person\_organization specifies the organization or person and organization that has granted the approval.

#### 4.2.18.4 role

The role specifies the text that indicates the role of the considered person or organization with respect to the approval. The role need not be specified for a particular Approving\_person\_organization. By default, the person or organization shall only be considered as an approver without any specific role.

EXAMPLE 'quality insurance auditor', 'production cost examiner' are examples of values of role of persons or organizations with respect to approvals assigned to product data.

#### 4.2.19 Area\_measure

An Area\_measure is a type of Value\_with\_tolerance (see 4.2.403) in which the value\_component describes an area.

#### 4.2.20 Assigned\_date

An Assigned\_date is an association between a role and a date.

NOTE This definition is based on the equivalent assignment definition in ISO 10303-1014 [12].

The data associated with an Assigned\_date are the following:

- date\_value;
- role.

##### 4.2.20.1 date\_value

The date\_value specifies the date that is assigned.

##### 4.2.20.2 role

The role specifies the text that indicates the role of the considered date.

EXAMPLE 'creation date', and 'release date' are example role values of dates assigned to product data.

#### 4.2.21 Assigned\_organization

An Assigned\_organization is an association between a role and an organization.

NOTE This definition is based on the equivalent assignment definition in ISO 10303-1013 [11].

The data associated with an Assigned\_organization are the following:

- organization\_value;
- role.

#### **4.2.21.1 organization\_value**

The organization\_value specifies the organization that is assigned.

#### **4.2.21.2 role**

The role specifies the text that indicates the role of the considered organization.

EXAMPLE 'creator', and 'part supplier' are example role values of organizations assigned to product data.

#### **4.2.22 Assigned\_person**

An Assigned\_person is an association between a role and a person and organization.

NOTE This definition is based on the equivalent assignment definition in ISO 10303-1013.

The data associated with an Assigned\_person are the following:

- person\_and\_organization\_value;
- role.

#### **4.2.22.1 person\_and\_organization\_value**

The person\_and\_organization\_value specifies the person and organization that is assigned.

#### **4.2.22.2 role**

The role specifies the text that indicates the role of the considered person and organization.

EXAMPLE 'design owner', 'creator', and 'part supplier' are example role values of persons assigned to product data.

#### **4.2.23 Assigned\_time**

An Assigned\_time is an association between a role and a date and time.

NOTE This definition is based on the equivalent assignment definition in ISO 10303-1014.

The data associated with an Assigned\_time are the following:

- date\_and\_time\_value;
- role.



### 4.2.23.1 date\_and\_time\_value

The date\_and\_time\_value specifies the date and time that is assigned.

### 4.2.23.2 role

The role specifies the text that indicates the role of the considered date and time.

EXAMPLE 'creation date', and 'release date' are example role values of date and times assigned to product data.

## 4.2.24 Assignment

The Assignment application object is defined by clause 4.6 of ISO 14649-10:2004.

NOTE The ISO 14649 EXPRESS description for Assignment is shown below. Refer to ISO 14649-10 for the complete definition and explanation of usage.

```
ENTITY assignment
  SUBTYPE OF (program_structure);
  its_lvalue:          nc_variable;
  its_rvalue:         rvalue;
END_ENTITY;

TYPE rvalue = SELECT(nc_constant, nc_variable);
END_TYPE;
```

## 4.2.25 Axis\_trajectory

The Axis\_trajectory application object is defined by clause 4.8 of ISO 14649-10:2004. This part of ISO 10303 adds the following information requirements.

The data associated with an Axis\_trajectory are the following:

- all of the data defined by ISO 14649-10, as modified below for the commands attribute.

NOTE The ISO 14649 EXPRESS description for Axis\_trajectory is shown below. Refer to ISO 14649-10 for the complete definition and explanation of usage.

```
ENTITY axis_trajectory(* m0 *)
  SUBTYPE OF (trajectory);
  axis_list:          LIST [1:?] OF identifier;
  commands:          LIST [1:?] OF bounded_curve;
WHERE
  WR1: SIZEOF(QUERY(cmd <* commands |
  cmd\geometric_representation_item.dim <> 1)) = 0;
END_ENTITY;
```

### 4.2.25.1 commands

The commands parameter is as defined by ISO 14649-10, but this part of ISO 10303 adds the requirement that the parameterisation of each bounded\_curve shall be the same. See 5.2.1.6.1 for additional discussion on curve parameterization.

### 4.2.26 Back\_boring

The Back\_boring application object is defined by clause 4 of ISO 14649-11:2004.

NOTE The ISO 14649 EXPRESS description for Back\_boring is shown below. Refer to ISO 14649-11 for the complete definition and explanation of usage.

```
ENTITY back_boring
  SUBTYPE OF (drilling_type_operation);
  WHERE
    WR1: EXISTS(SELF.its_machine_functions.oriented_spindle_stop);
  END_ENTITY;
```

### 4.2.27 Ballnose\_endmill

The Ballnose\_endmill application object is defined by clause 4 of ISO 14649-11:—.

NOTE The ISO 14649 EXPRESS description for Ballnose\_endmill is shown below. Refer to ISO 14649-111 for the complete definition and explanation of usage.

```
ENTITY ballnose_endmill
  SUBTYPE OF (endmill);
  WHERE
    WR1: NOT EXISTS(SELF.edge_radius)
      OR (EXISTS(SELF.edge_radius) AND
          EXISTS(SELF.effective_cutting_diameter) AND
          (SELF.edge_radius = SELF.effective_cutting_diameter/2));
  END_ENTITY;
```

### 4.2.28 Bidirectional

The Bidirectional application object is defined by clause 4 of ISO 14649-11:2004.

NOTE The ISO 14649 EXPRESS description for Bidirectional is shown below. Refer to ISO 14649-11 for the complete definition and explanation of usage.

```
ENTITY bidirectional
  SUBTYPE OF (two5D_milling_strategy);
  feed_direction:      OPTIONAL direction;
  stepover_direction:  OPTIONAL left_or_right;
  its_stroke_connection_strategy: OPTIONAL stroke_connection_strategy;
  END_ENTITY;

  TYPE left_or_right = ENUMERATION OF (left, right);
  END_TYPE;

  TYPE stroke_connection_strategy = ENUMERATION OF
```

```
(straghtline, lift_shift_plunge, degouge, loop_back);
END_TYPE;
```

### 4.2.29 Bidirectional\_contour

The Bidirectional\_contour application object is defined by clause 4 of ISO 14649-11:2004.

NOTE The ISO 14649 EXPRESS description for Bidirectional\_contour is shown below. Refer to ISO 14649-11 for the complete definition and explanation of usage.

```
ENTITY bidirectional_contour
  SUBTYPE OF (two5D_milling_strategy);
  feed_direction:      OPTIONAL direction;
  stepover_direction:  OPTIONAL left_or_right;
  rotation_direction:  OPTIONAL rot_direction;
  spiral_cutmode:     OPTIONAL cutmode_type;
END_ENTITY;

TYPE rot_direction = ENUMERATION OF (cw, ccw);
END_TYPE;
```

### 4.2.30 Bidirectional\_turning

The Bidirectional\_turning application object is defined by clause 4.4 of ISO 14649-12:2005.

NOTE The ISO 14649 EXPRESS description for Bidirectional\_turning is shown below. Refer to ISO 14649-12 for the complete definition and explanation of usage.

```
ENTITY bidirectional_turning
  SUBTYPE OF (turning_machining_strategy);
  feed_direction : OPTIONAL direction;
  stepover_direction : OPTIONAL direction;
  stepover_feed : OPTIONAL feed_select;
END_ENTITY;
```

### 4.2.31 Binary\_boolean\_expression

The Binary\_boolean\_expression application object is defined by clause 4.6 of ISO 14649-10:2004.

NOTE The ISO 14649 EXPRESS description for Binary\_boolean\_expression is shown below. Refer to ISO 14649-10 for the complete definition and explanation of usage.

```
ENTITY binary_boolean_expression
  ABSTRACT SUPERTYPE OF (xor_expression)
  SUBTYPE OF (boolean_expression);
  operand1: boolean_expression;
  operand2: boolean_expression;
END_ENTITY;
```

### 4.2.32 Blind\_bottom\_condition

The Blind\_bottom\_condition application object is defined by clause 4.5 of ISO 14649-10:2004.

NOTE The ISO 14649 EXPRESS description for Blind\_bottom\_condition is shown below. Refer to ISO 14649-10 for the complete definition and explanation of usage.

```
ENTITY blind_bottom_condition
  ABSTRACT SUPERTYPE OF (ONEOF(flat_hole_bottom, flat_with_radius_hole_bottom,
    spherical_hole_bottom, conical_hole_bottom))
  SUBTYPE OF (hole_bottom_condition);
END_ENTITY;
```

### 4.2.33 Boolean\_expression

The Boolean\_expression application object is defined by clause 4.6 of ISO 14649-10:2004.

NOTE The ISO 14649 EXPRESS description for Boolean\_expression is shown below. Refer to ISO 14649-10 for the complete definition and explanation of usage.

```
ENTITY boolean_expression
  ABSTRACT SUPERTYPE OF (ONEOF(unary_boolean_expression, binary_boolean_expression,
    multiple_arity_boolean_expression, comparison_expression));
END_ENTITY;
```

### 4.2.34 Boring

The Boring application object is defined by clause 4 of ISO 14649-11:2004.

NOTE The ISO 14649 EXPRESS description for Boring is shown below. Refer to ISO 14649-11 for the complete definition and explanation of usage.

```
ENTITY boring
  SUBTYPE OF (boring_operation);
END_ENTITY;
```

### 4.2.35 Boring\_operation

The Boring\_operation application object is defined by clause 4 of ISO 14649-11:2004.

NOTE The ISO 14649 EXPRESS description for Boring\_operation is shown below. Refer to ISO 14649-11 for the complete definition and explanation of usage.

```
ENTITY boring_operation
  ABSTRACT SUPERTYPE OF (ONEOF(boring, reaming))
  SUBTYPE OF (drilling_type_operation);
  spindle_stop_at_bottom:      BOOLEAN;
  depth_of_testcut:            OPTIONAL length_measure;
  waiting_position:            OPTIONAL cartesian_point;
END_ENTITY;
```

### 4.2.36 Boss

The Boss application object is defined by clause 4.5 of ISO 14649-10:2004. This part of ISO 10303 adds the following information requirements to the Boss application object.

The data associated with a Boss are the following:

- all of the data defined by ISO 14649-10;
- boss\_height.

NOTE The ISO 14649 EXPRESS description for Boss, as adapted by this part of ISO 10303, is shown below. Refer to ISO 14649-10 for the original definition and explanation of usage.

```
ENTITY boss
  SUBTYPE OF (machining_feature);
  its_boundary:      closed_profile;
  slope:             OPTIONAL plane_angle_measure;
  boss_height:      linear_path;      -- ADDED BY 10303-238
END_ENTITY;
```

### 4.2.36.1 boss\_height

The boss\_height specifies a Linear\_path along which the its\_boundary profile is swept to define the volume of the Boss. The placement and orientation of the course\_of\_travel shall be the same as the Boss feature. See 4.3.6 for the application assertion.

NOTE The length of the path is the height of the boss.

### 4.2.37 Bottom\_and\_side\_finish\_milling

The Bottom\_and\_side\_finish\_milling application object is defined by clause 4 of ISO 14649-11:2004.

NOTE The ISO 14649 EXPRESS description for Bottom\_and\_side\_finish\_milling is shown below. Refer to ISO 14649-11 for the complete definition and explanation of usage.

```
ENTITY bottom_and_side_finish_milling
  SUBTYPE OF (bottom_and_side_milling);
END_ENTITY;
```

### 4.2.38 Bottom\_and\_side\_milling

The Bottom\_and\_side\_milling application object is defined by clause 4 of ISO 14649-11:2004.

NOTE The ISO 14649 EXPRESS description for Bottom\_and\_side\_milling is shown below. Refer to ISO 14649-11 for the complete definition and explanation of usage.

```
ENTITY bottom_and_side_milling
  ABSTRACT SUPERTYPE OF (ONEOF(bottom_and_side_rough_milling,
    bottom_and_side_finish_milling))
  SUBTYPE OF (two5D_milling_operation);
  axial_cutting_depth:  OPTIONAL length_measure;
  radial_cutting_depth: OPTIONAL length_measure;
  allowance_side:       OPTIONAL length_measure;
  allowance_bottom:     OPTIONAL length_measure;
END_ENTITY;
```

## 4.2.39 Bottom\_and\_side\_rough\_milling

The Bottom\_and\_side\_rough\_milling application object is defined by clause 4 of ISO 14649-11:2004.

NOTE The ISO 14649 EXPRESS description for Bottom\_and\_side\_rough\_milling is shown below. Refer to ISO 14649-11 for the complete definition and explanation of usage.

```
ENTITY bottom_and_side_rough_milling
  SUBTYPE OF (bottom_and_side_milling);
WHERE
  WR1: EXISTS(SELF.allowance_side) AND (SELF.allowance_side>=0.0);
  WR2: EXISTS(SELF.allowance_bottom) AND (SELF.allowance_bottom>=0.0);
END_ENTITY;
```

## 4.2.40 BSU

A BSU is the identification of a piece of information, that can be a supplier, a class or a property, by specifying a code and a version. Each BSU is either a Supplier\_BSU (see 4.2.328), a Class\_BSU (see 4.2.55), or a Property\_BSU (see 4.2.271).

NOTE 1 BSU is an acronym for basic semantical unit.

NOTE 2 This definition has been harmonized with the BSU definitions in ISO 10303-224 and ISO 10303-240.

The data associated with a BSU are the following:

— code.

### 4.2.40.1 code

The code specifies the designation of the identification of the information piece.

## 4.2.41 Bullnose\_endmill

The Bullnose\_endmill application object is defined by clause 4 of ISO 14649-111:—.

NOTE The ISO 14649 EXPRESS description for Bullnose\_endmill is shown below. Refer to ISO 14649-111 for the complete definition and explanation of usage.

```
ENTITY bullnose_endmill
  SUBTYPE OF (endmill);
WHERE
  WR1: EXISTS(SELF.edge_radius) AND
        EXISTS(SELF.effective_cutting_diameter) AND
        (SELF.edge_radius < SELF.effective_cutting_diameter/2);
END_ENTITY;
```

## 4.2.42 Catalogue\_thread

The Catalogue\_thread application object is defined by clause 4.5 of ISO 14649-10:2004.

NOTE The ISO 14649 EXPRESS description for Catalogue\_thread is shown below. Refer to ISO 14649-10 for the complete definition and explanation of usage.

```
ENTITY catalogue_thread
  SUBTYPE OF (thread);
  documentation:      specification;
END_ENTITY;
```

#### 4.2.43 Center\_drilling

The Center\_drilling application object is defined by clause 4 of ISO 14649-11:2004.

NOTE The ISO 14649 EXPRESS description for Center\_drilling is shown below. Refer to ISO 14649-11 for the complete definition and explanation of usage.

```
ENTITY center_drilling
  SUBTYPE OF (drilling_operation);
END_ENTITY;
```

#### 4.2.44 Center\_milling

The Center\_milling application object is defined by clause 4 of ISO 14649-11:2004.

NOTE The ISO 14649 EXPRESS description for Center\_milling is shown below. Refer to ISO 14649-11 for the complete definition and explanation of usage.

```
ENTITY center_milling
  SUBTYPE OF (two5D_milling_strategy);
END_ENTITY;
```

#### 4.2.45 Chamfer

The Chamfer application object is defined by clause 4.5 of ISO 14649-10:2004. This part of ISO 10303 adds the following information requirements. See 5.2.1.3.7 for additional discussion on these information requirements.

NOTE 1 As originally defined by ISO 14649-10, a Chamfer can only describe a transition between two features. For harmonization with ISO 10303-224 and other ISO 10303 parts, the following properties have been added so that a Chamfer can also describe a transition between two sets of faces on the boundary representation of the workpiece.

The data associated with a Chamfer are the following:

- all of the data defined by ISO 14649-10;
- chamfer\_face;
- first\_face\_shape;

— second\_face\_shape.

NOTE 2 The ISO 14649 EXPRESS description for Chamfer, as adapted by this part of ISO 10303, is shown below. Refer to ISO 14649-10 for the original definition and explanation of usage.

```

ENTITY chamfer
  SUBTYPE OF (transition_feature);
  angle_to_plane:      plane_angle_measure;
  first_offset_amount: toleranced_length_measure;
  chamfer_face:        OPTIONAL SET [1:?] OF face; -- ADDED BY 10303-238
  first_face_shape:    OPTIONAL SET [1:?] OF face; -- ADDED BY 10303-238
  second_face_shape:   OPTIONAL SET [1:?] OF face; -- ADDED BY 10303-238
END_ENTITY;

```

#### 4.2.45.1 chamfer\_face

The chamfer\_face specifies the flat transition surface located between the first\_face\_shape and the second\_face\_shape surfaces. This is a set of one or more faces on the boundary representation of the workpiece. The chamfer\_face need not be specified for a particular Chamfer.

#### 4.2.45.2 first\_face\_shape

The first\_face\_shape specifies one of two surfaces that the Chamfer feature will create a transition between. This is a set of one or more faces on the boundary representation of the workpiece. The first\_face\_shape need not be specified for a particular Chamfer.

#### 4.2.45.3 second\_face\_shape

The second\_face\_shape specifies the other surface that the Chamfer feature will create a transition between. This is a set of one or more faces on the boundary representation of the workpiece. The second\_face\_shape need not be specified for a particular Chamfer.

#### 4.2.46 Chamfered\_corner

The Chamfered\_corner application object is defined by clause 4 of ISO 14649-121:2005.

NOTE The ISO 14649 EXPRESS description for Chamfered\_corner is shown below. Refer to ISO 14649-121 for the complete definition and explanation of usage.

```

ENTITY chamfered_corner;
  corner_chamfer_angle:      plane_angle_measure;
  corner_chamfer_length:     OPTIONAL length_measure;
  corner_chamfer_width:      OPTIONAL length_measure;
END_ENTITY;

```

#### 4.2.47 Channel

The Channel application object is defined by clause 4.6 of ISO 14649-10:2004.



NOTE The ISO 14649 EXPRESS description for Channel is shown below. Refer to ISO 14649-10 for the complete definition and explanation of usage.

```
ENTITY channel;
  its_id: identifier;
END_ENTITY;
```

#### 4.2.48 Circular\_closed\_profile

The Circular\_closed\_profile application object is defined by clause 4.5 of ISO 14649-10:2004.

NOTE The ISO 14649 EXPRESS description for Circular\_closed\_profile is shown below. Refer to ISO 14649-10 for the complete definition and explanation of usage.

```
ENTITY circular_closed_profile
  SUBTYPE OF (closed_profile);
  diameter:          toleranced_length_measure;
END_ENTITY;
```

#### 4.2.49 Circular\_closed\_shape\_profile

The Circular\_closed\_shape\_profile application object is defined by clause 4.5 of ISO 14649-10:2004.

NOTE The ISO 14649 EXPRESS description for Circular\_closed\_shape\_profile is shown below. Refer to ISO 14649-10 for the complete definition and explanation of usage.

```
ENTITY circular_closed_shape_profile
  SUBTYPE OF (shape_profile);
  closed_boundary : circular_closed_profile;
END_ENTITY;
```

#### 4.2.50 Circular\_offset

The Circular\_offset application object is defined by clause 4.5 of ISO 14649-10:2004.

NOTE The ISO 14649 EXPRESS description for Circular\_offset is shown below. Refer to ISO 14649-10 for the complete definition and explanation of usage.

```
ENTITY circular_offset;
  angular_offset:          plane_angle_measure;
  index:                  INTEGER;
END_ENTITY;
```

#### 4.2.51 Circular\_omit

The Circular\_omit application object is defined by clause 4.5 of ISO 14649-10:2004.

NOTE The ISO 14649 EXPRESS description for Circular\_omit is shown below. Refer to ISO 14649-10 for the complete definition and explanation of usage.

```

ENTITY circular_omit;
  index:                INTEGER;
END_ENTITY;

```

## 4.2.52 Circular\_path

The Circular\_path application object is defined by clause 4.5 of ISO 14649-10:2004.

NOTE The ISO 14649 EXPRESS description for Circular\_path is shown below. Refer to ISO 14649-10 for the complete definition and explanation of usage.

```

ENTITY circular_path
  ABSTRACT SUPERTYPE OF(ONEOF(complete_circular_path, partial_circular_path))
  SUBTYPE OF(travel_path);
  radius:                toleranced_length_measure;
END_ENTITY;

```

## 4.2.53 Circular\_pattern

The Circular\_pattern application object is defined by clause 4.5 of ISO 14649-10:2004.

NOTE The ISO 14649 EXPRESS description for Circular\_pattern is shown below. Refer to ISO 14649-10 for the complete definition and explanation of usage.

```

ENTITY circular_pattern
  SUBTYPE OF(replicate_feature);
  angle_increment:       plane_angle_measure;
  number_of_feature:     INTEGER;
  relocated_base_feature: SET[0:?] OF circular_offset;
  missing_base_feature:  SET[0:?] OF circular_omit;
  base_feature_diameter: OPTIONAL toleranced_length_measure;
  base_feature_rotation: plane_angle_measure;
END_ENTITY;

```

## 4.2.54 Circular\_runout\_tolerance

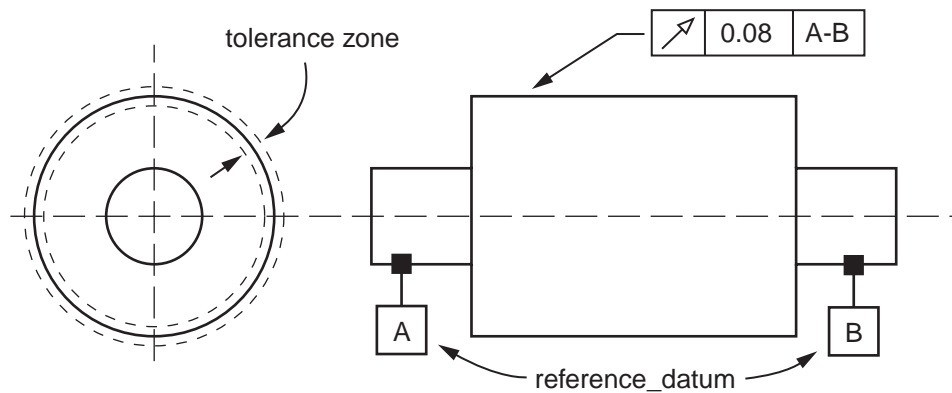
A Circular\_runout\_tolerance is a type of Geometric\_tolerance (see 4.2.156) that specifies a constraint on the circularity of curves pertaining to a surface described by the rotation of a part about an axis. The tolerance is applied independently at any circular measuring position as the part is rotated 360 degrees.

NOTE 1 This definition has been harmonized with the Circular\_runout\_tolerance definitions in ISO 10303-1051, ISO 10303-214, and ISO 10303-224. This definition is derived from clause 14.13 of ISO 1101:2004.

NOTE 2 Where applied to surfaces constructed around a datum axis, a Circular\_runout\_tolerance controls the cumulative variations of circularity and coaxiality. Where applied to surfaces constructed at right angles to the datum axis, Circular\_runout\_tolerance controls circular elements of a plane surface. Figure 5 illustrates a Circular\_runout\_tolerance.

The data associated with a Circular\_runout\_tolerance are the following:

— angle;



**Figure 5 — Circular\_runout\_tolerance**

— reference\_datum.

#### 4.2.54.1 angle

The angle specifies the direction in which the runout tolerance is controlled. The angle need not be specified for a particular Circular\_runout\_tolerance. If the angle is specified, the runout tolerance applies in this angle which is fixed with respect to the datum axis. If the angle is not specified, the runout tolerance applies normal to the surface generated by the rotation.

#### 4.2.54.2 reference\_datum

The reference\_datum specifies the set of Datum\_reference objects that define the reference frame for the geometric tolerance. See 4.3.7 for the application assertion.

#### 4.2.55 Class\_BSU

A Class\_BSU is a type of BSU (see 4.2.40) that identifies a class in a parts library.

NOTE 1 The combination of supplier identification, code, and version of a class shall be unique.

NOTE 2 This definition has been harmonized with the Class\_BSU definitions in ISO 10303-224 and ISO 10303-240.

The data associated with a Class\_BSU are the following:

- defined\_by;
- version.

### 4.2.55.1 defined\_by

The defined\_by specifies Supplier\_BSU object which describes the library supplier who defines the library class. See 4.3.8 for the application assertion.

### 4.2.55.2 version

The version specifies the designation of the version of the information piece.

### 4.2.56 Closed\_pocket

The Closed\_pocket application object is defined by clause 4.5 of ISO 14649-10:2004.

NOTE The ISO 14649 EXPRESS description for Closed\_pocket is shown below. Refer to ISO 14649-10 for the complete definition and explanation of usage.

```
ENTITY closed_pocket
  SUBTYPE OF (pocket);
  feature_boundary:      closed_profile;
END_ENTITY;
```

### 4.2.57 Closed\_profile

The Closed\_profile application object is defined by clause 4.5 of ISO 14649-10:2004.

NOTE The ISO 14649 EXPRESS description for Closed\_profile is shown below. Refer to ISO 14649-10 for the complete definition and explanation of usage.

```
ENTITY closed_profile
  ABSTRACT SUPERTYPE OF
    (ONEOF (rectangular_closed_profile, circular_closed_profile,
           ngon_profile, general_closed_profile))
  SUBTYPE OF(profile);
END_ENTITY;
```

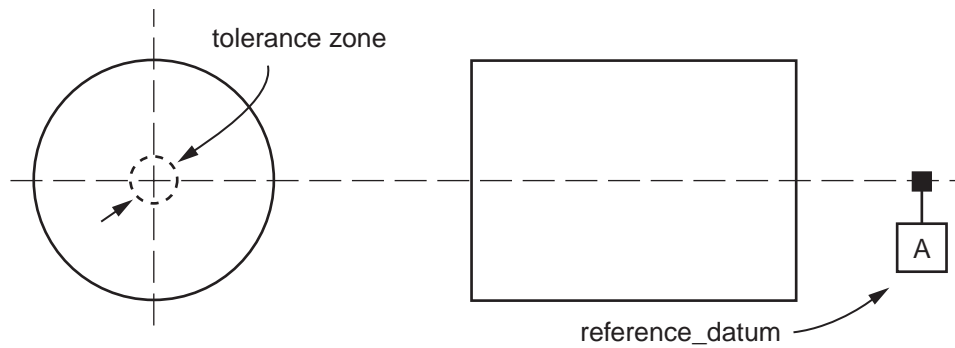
### 4.2.58 Coaxiality\_tolerance

A Coaxiality\_tolerance is a type of Geometric\_tolerance (see 4.2.156) that specifies a constraint where the tolerance zone is limited by a cylinder, the diameter of which is the tolerance value. The cylinder axis is defined by the datums that are referenced.

NOTE This definition has been harmonized with the Coaxiality\_tolerance definitions in ISO 10303-1051, ISO 10303-214, and ISO 10303-224. Figure 6 illustrates a Coaxiality\_tolerance.

The data associated with a Coaxiality\_tolerance are the following:

- reference\_datum.



**Figure 6 — Coaxiality\_tolerance**

#### 4.2.58.1 reference\_datum

The `reference_datum` specifies the set of Datum\_reference objects that define the reference frame for the geometric tolerance. See 4.3.9 for the application assertion.

#### 4.2.59 Combined\_drill\_and\_reamer

The `Combined_drill_and_reamer` application object is defined by clause 4 of ISO 14649-111:—.

NOTE The ISO 14649 EXPRESS description for `Combined_drill_and_reamer` is shown below. Refer to ISO 14649-111 for the complete definition and explanation of usage.

```
ENTITY combined_drill_and_reamer
  SUBTYPE OF (reaming_cutting_tool);
  drill_length: length_measure;
END_ENTITY;
```

#### 4.2.60 Combined\_drill\_and\_tap

The `Combined_drill_and_tap` application object is defined by clause 4 of ISO 14649-111:—.

NOTE The ISO 14649 EXPRESS description for `Combined_drill_and_tap` is shown below. Refer to ISO 14649-111 for the complete definition and explanation of usage.

```
ENTITY combined_drill_and_tap
  SUBTYPE OF (tapping_cutting_tool);
  drill_length: OPTIONAL length_measure;
END_ENTITY;
```

#### 4.2.61 Common\_datum

A `Common_datum` is a type of Datum (see 4.2.100) defined by a set of two `Single_datum` objects of equal importance which are used to establish a single datum plane or axis.

ISO 10303-238:2007(E)

NOTE This definition has been harmonized with the `Common_datum` definition in ISO 10303-1051, and the `Compound_datum` definition in ISO 10303-214 and ISO 10303-224.

The data associated with a `Common_datum` are the following:

— `made_up_by`.

#### 4.2.61.1 `made_up_by`

The `made_up_by` specifies the set of `Single_datum` objects that form the `Common_datum`. See 4.3.10 for the application assertion.

#### 4.2.62 `Comparison_equal`

The `Comparison_equal` application object is defined by clause 4.6 of ISO 14649-10:2004.

NOTE The ISO 14649 EXPRESS description for `Comparison_equal` is shown below. Refer to ISO 14649-10 for the complete definition and explanation of usage.

```
ENTITY comparison_equal
  SUBTYPE OF (comparison_expression);
END_ENTITY;
```

#### 4.2.63 `Comparison_expression`

The `Comparison_expression` application object is defined by clause 4.6 of ISO 14649-10:2004.

NOTE The ISO 14649 EXPRESS description for `Comparison_expression` is shown below. Refer to ISO 14649-10 for the complete definition and explanation of usage.

```
ENTITY comparison_expression
  ABSTRACT SUPERTYPE OF (ONEOF (comparison_equal, comparison_not_equal,
    comparison_greater, comparison_greater_equal, comparison_less,
    comparison_less_equal))
  SUBTYPE OF (boolean_expression);
  operand1: nc_variable;
  operand2: rvalue;
END_ENTITY;
```

#### 4.2.64 `Comparison_greater`

The `Comparison_greater` application object is defined by clause 4.6 of ISO 14649-10:2004.

NOTE The ISO 14649 EXPRESS description for `Comparison_greater` is shown below. Refer to ISO 14649-10 for the complete definition and explanation of usage.

```
ENTITY comparison_greater
  SUBTYPE OF (comparison_expression);
END_ENTITY;
```

### 4.2.65 Comparison\_greater\_equal

The Comparison\_greater\_equal application object is defined by clause 4.6 of ISO 14649-10:2004.

NOTE The ISO 14649 EXPRESS description for Comparison\_greater\_equal is shown below. Refer to ISO 14649-10 for the complete definition and explanation of usage.

```
ENTITY comparison_greater_equal
  SUBTYPE OF (comparison_expression);
END_ENTITY;
```

### 4.2.66 Comparison\_less

The Comparison\_less application object is defined by clause 4.6 of ISO 14649-10:2004.

NOTE The ISO 14649 EXPRESS description for Comparison\_less is shown below. Refer to ISO 14649-10 for the complete definition and explanation of usage.

```
ENTITY comparison_less
  SUBTYPE OF (comparison_expression);
END_ENTITY;
```

### 4.2.67 Comparison\_less\_equal

The Comparison\_less\_equal application object is defined by clause 4.6 of ISO 14649-10:2004.

NOTE The ISO 14649 EXPRESS description for Comparison\_less\_equal is shown below. Refer to ISO 14649-10 for the complete definition and explanation of usage.

```
ENTITY comparison_less_equal
  SUBTYPE OF (comparison_expression);
END_ENTITY;
```

### 4.2.68 Comparison\_not\_equal

The Comparison\_not\_equal application object is defined by clause 4.6 of ISO 14649-10:2004.

NOTE The ISO 14649 EXPRESS description for Comparison\_not\_equal is shown below. Refer to ISO 14649-10 for the complete definition and explanation of usage.

```
ENTITY comparison_not_equal
  SUBTYPE OF (comparison_expression);
END_ENTITY;
```

### 4.2.69 Complete\_circular\_path

The Complete\_circular\_path application object is defined by clause 4.5 of ISO 14649-10:2004.

NOTE The ISO 14649 EXPRESS description for `Complete_circular_path` is shown below. Refer to ISO 14649-10 for the complete definition and explanation of usage.

```
ENTITY complete_circular_path
  SUBTYPE OF (circular_path);
END_ENTITY;
```

## 4.2.70 Compound\_feature

The `Compound_feature` application object is defined by clause 4.5 of ISO 14649-10:2004. This part of ISO 10303 adds the following information requirements to the `Compound_feature` application object.

NOTE 1 The name and description properties have been added for harmonization with ISO 10303-224 and other ISO 10303 parts.

The data associated with a `Compound_feature` are the following:

- all of the data defined by ISO 14649-10;
- `feature_description`;
- `feature_name`.

NOTE 2 The ISO 14649 EXPRESS description for `Compound_feature`, as adapted by this part of ISO 10303, is shown below. Refer to ISO 14649-10 for the original definition and explanation of usage.

```
ENTITY compound_feature
  SUPERTYPE OF (ONEOF(counterbore_hole, countersunk_hole))
  SUBTYPE OF (two5D_manufacturing_feature);
elements: SET [2:?] OF compound_feature_select;
feature_description: OPTIONAL text; -- ADDED BY 10303-238
feature_name: label; -- ADDED BY 10303-238
WHERE
  WR1: SIZEOF(QUERY(e <* elements |
    SIZEOF(e\manufacturing_feature.its_operations) <> 0)) = 0;
END_ENTITY;

TYPE compound_feature_select = SELECT(machining_feature, transition_feature);
END_TYPE;
```

### 4.2.70.1 feature\_description

The `feature_description` specifies text that provides further information about the `Compound_feature`. The `feature_description` need not be specified for a particular `Compound_feature`.

### 4.2.70.2 feature\_name

The `feature_name` specifies a name for the `Compound_feature`. The `feature_name` need not be unique.

NOTE This is separate from the `its_id` property. In the integrated representation, `its_id` is the `shape_aspect` name and `feature_name` is the `characterized_object` name.

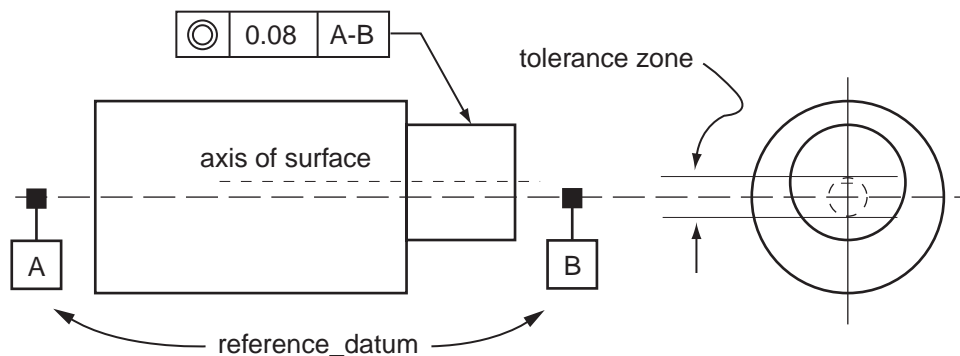


## 4.2.71 Concentricity\_tolerance

A Concentricity\_tolerance is a type of Geometric\_tolerance (see 4.2.156) that specifies a constraint defining one of the following two conditions:

- a condition where the axes of all cross-sectional elements of a surface of revolution perpendicular to the axis of a datum feature are common to this axis. In this case, it implies a cylindrical tolerance zone whose axis coincides with the datum axis and within which all cross-sectional axes of the feature being controlled shall lie;
- a condition where the centre point of one sphere is common to the centre point of another sphere. In this case, it implies a spherical tolerance zone within which the centre point of the first sphere shall lie.

NOTE This definition has been harmonized with the Concentricity\_tolerance definitions in ISO 10303-1051, ISO 10303-214, and ISO 10303-224. This definition is derived from clause 14.11 of ISO 1101:2004. Figure 7 illustrates a Concentricity\_tolerance.



**Figure 7 — Concentricity\_tolerance**

The data associated with a Concentricity\_tolerance are the following:

- reference\_datum.

### 4.2.71.1 reference\_datum

The reference\_datum specifies the set of Datum\_reference objects that define the reference frame for the geometric tolerance. See 4.3.11 for the application assertion.

## 4.2.72 Conical\_hole\_bottom

The Conical\_hole\_bottom application object is defined by clause 4.5 of ISO 14649-10:2004.

NOTE The ISO 14649 EXPRESS description for Conical\_hole\_bottom is shown below. Refer to ISO 14649-10 for the complete definition and explanation of usage.

```
ENTITY conical_hole_bottom
  SUBTYPE OF (blind_bottom_condition);
  tip_angle:      plane_angle_measure;
  tip_radius:    OPTIONAL tolerated_length_measure;
END_ENTITY;
```

### 4.2.73 Connect\_direct

The Connect\_direct application object is defined by clause 4.8 of ISO 14649-10:2004.

NOTE The ISO 14649 EXPRESS description for Connect\_direct is shown below. Refer to ISO 14649-10 for the complete definition and explanation of usage.

```
ENTITY connect_direct
  SUBTYPE OF (connector);
END_ENTITY;
```

### 4.2.74 Connect\_secplane

The Connect\_secplane application object is defined by clause 4.8 of ISO 14649-10:2004.

NOTE The ISO 14649 EXPRESS description for Connect\_secplane is shown below. Refer to ISO 14649-10 for the complete definition and explanation of usage.

```
ENTITY connect_secplane
  SUBTYPE OF (connector);
  up_dir  : OPTIONAL direction;
  down_dir: OPTIONAL direction;
END_ENTITY;
```

### 4.2.75 Connector

The Connector application object is defined by clause 4.8 of ISO 14649-10:2004.

NOTE The ISO 14649 EXPRESS description for Connector is shown below. Refer to ISO 14649-10 for the complete definition and explanation of usage.

```
ENTITY connector
  ABSTRACT SUPERTYPE OF (ONEOF(connect_secplane, connect_direct))
  SUBTYPE OF (parameterised_path);
END_ENTITY;
```

### 4.2.76 Const\_cutting\_speed

The Const\_cutting\_speed application object is defined by clause 4.4 of ISO 14649-12:2005.

NOTE The ISO 14649 EXPRESS description for Const\_cutting\_speed is shown below. Refer to ISO 14649-12 for the complete definition and explanation of usage.

```
ENTITY const_cutting_speed;
  speed : speed_measure;
  max_speed : OPTIONAL rot_speed_measure;
END_ENTITY;
```

### 4.2.77 Const\_spindle\_speed

The Const\_spindle\_speed application object is defined by clause 4.4 of ISO 14649-12:2005.

NOTE The ISO 14649 EXPRESS description for Const\_spindle\_speed is shown below. Refer to ISO 14649-12 for the complete definition and explanation of usage.

```
ENTITY const_spindle_speed;
  rot_speed : rot_speed_measure;
END_ENTITY;
```

### 4.2.78 Contour\_bidirectional

The Contour\_bidirectional application object is defined by clause 4 of ISO 14649-11:2004.

NOTE The ISO 14649 EXPRESS description for Contour\_bidirectional is shown below. Refer to ISO 14649-11 for the complete definition and explanation of usage.

```
ENTITY contour_bidirectional
  SUBTYPE OF (two5D_milling_strategy);
  feed_direction:      OPTIONAL direction;
  stepover_direction:  OPTIONAL left_or_right;
  rotation_direction:  OPTIONAL rot_direction;
  spiral_cutmode:      OPTIONAL cutmode_type;
END_ENTITY;
```

### 4.2.79 Contour\_parallel

The Contour\_parallel application object is defined by clause 4 of ISO 14649-11:2004.

NOTE The ISO 14649 EXPRESS description for Contour\_parallel is shown below. Refer to ISO 14649-11 for the complete definition and explanation of usage.

```
ENTITY contour_parallel
  SUBTYPE OF (two5D_milling_strategy);
  rotation_direction:  OPTIONAL rot_direction;
  cutmode:             OPTIONAL cutmode_type;
END_ENTITY;
```

### 4.2.80 Contour\_spiral

The Contour\_spiral application object is defined by clause 4 of ISO 14649-11:2004.

NOTE The ISO 14649 EXPRESS description for Contour\_spiral is shown below. Refer to ISO 14649-11 for the complete definition and explanation of usage.

```
ENTITY contour_spiral
  SUBTYPE OF (two5D_milling_strategy);
  rotation_direction:  OPTIONAL rot_direction;
  cutmode:             OPTIONAL cutmode_type;
END_ENTITY;
```

### 4.2.81 Contour\_turning

The Contour\_turning application object is defined by clause 4.4 of ISO 14649-12:2005.

NOTE The ISO 14649 EXPRESS description for Contour\_turning is shown below. Refer to ISO 14649-12 for the complete definition and explanation of usage.

```
ENTITY contour_turning
  SUBTYPE OF (turning_machining_strategy);
  feed_direction:      OPTIONAL direction;
  back_path_direction: OPTIONAL direction;
  lift_direction:      OPTIONAL direction;
  stepover_direction:  OPTIONAL direction;
  lift_height:         OPTIONAL length_measure;
  lift_feed:           OPTIONAL feed_select;
  stepover_feed:       OPTIONAL feed_select;
  variable_stepover_feed: OPTIONAL positive_ratio_measure;
END_ENTITY;
```

### 4.2.82 Contouring

The Contouring application object is defined by clause 4.4 of ISO 14649-12:2005.

NOTE The ISO 14649 EXPRESS description for Contouring is shown below. Refer to ISO 14649-12 for the complete definition and explanation of usage.

```
ENTITY contouring
  ABSTRACT SUPERTYPE OF (ONEOF(contouring_rough, contouring_finish))
  SUBTYPE OF (turning_machining_operation);
  allowance : OPTIONAL length_measure;
END_ENTITY;
```

### 4.2.83 Contouring\_finish

The Contouring\_finish application object is defined by clause 4.4 of ISO 14649-12:2005.

NOTE The ISO 14649 EXPRESS description for Contouring\_finish is shown below. Refer to ISO 14649-12 for the complete definition and explanation of usage.

```
ENTITY contouring_finish
  SUBTYPE OF (contouring);
END_ENTITY;
```

### 4.2.84 Contouring\_rough

The Contouring\_rough application object is defined by clause 4.4 of ISO 14649-12:2005.

NOTE The ISO 14649 EXPRESS description for Contouring\_rough is shown below. Refer to ISO 14649-12 for the complete definition and explanation of usage.

```

ENTITY contouring_rough
  SUBTYPE OF (contouring);
WHERE
  WR1: EXISTS(SELF.allowance) AND (SELF.allowance >= 0.0);
END_ENTITY;

```

### 4.2.85 Corner\_transition

The Corner\_transition application object is defined by clause 4 of ISO 14649-121:2005.

NOTE The ISO 14649 EXPRESS description for Corner\_transition is shown below. Refer to ISO 14649-121 for the complete definition and explanation of usage.

```

ENTITY corner_transition;
  corner_identity:    INTEGER;
  transition:         corner_transition_select;
END_ENTITY;

TYPE corner_transition_select = SELECT (
  chamfered_corner, rounded_corner, profiled_corner);
END_TYPE;

```

### 4.2.86 Counter\_sinking

The Counter\_sinking application object is defined by clause 4 of ISO 14649-11:2004.

NOTE The ISO 14649 EXPRESS description for Counter\_sinking is shown below. Refer to ISO 14649-11 for the complete definition and explanation of usage.

```

ENTITY counter_sinking
  SUBTYPE OF (drilling_operation);
END_ENTITY;

```

### 4.2.87 Counterbore

The Counterbore application object is defined by clause 4 of ISO 14649-111:—.

NOTE The ISO 14649 EXPRESS description for Counterbore is shown below. Refer to ISO 14649-111 for the complete definition and explanation of usage.

```

ENTITY counterbore
  SUBTYPE OF (drilling_cutting_tool);
END_ENTITY;

```

### 4.2.88 Counterbore\_hole

The Counterbore\_hole application object is defined by clause 4.5 of ISO 14649-10:2004.

NOTE The ISO 14649 EXPRESS description for Counterbore\_hole is shown below. Refer to ISO 14649-10 for the complete definition and explanation of usage.

```

ENTITY counterbore_hole
  SUBTYPE OF (compound_feature);

```

```

WHERE
WR1: SIZEOF(elements) =2;
WR2: (SIZEOF(QUERY ( it <* SELF.elements |
  (('ROUND_HOLE' IN TYPEOF(it))) )) = 2);
WR3: SELF.elements[1].diameter.theoretical_size <>
  SELF.elements[2].diameter.theoretical_size;
END_ENTITY;

```

## 4.2.89 Countersink

The Countersink application object is defined by clause 4 of ISO 14649-111:—.

NOTE The ISO 14649 EXPRESS description for Countersink is shown below. Refer to ISO 14649-111 for the complete definition and explanation of usage.

```

ENTITY countersink
  SUBTYPE OF (drilling_cutting_tool);
  minimum_cutting_diameter: OPTIONAL length_measure;
  maximum_usable_length: length_measure;
END_ENTITY;

```

## 4.2.90 Countersunk\_hole

The Countersunk\_hole application object is defined by clause 4.5 of ISO 14649-10:2004.

NOTE The ISO 14649 EXPRESS description for Countersunk\_hole is shown below. Refer to ISO 14649-10 for the complete definition and explanation of usage.

```

ENTITY countersunk_hole
  SUBTYPE OF (compound_feature);
WHERE
WR1: SIZEOF(elements) =2;
WR2: (SIZEOF(QUERY ( it <* SELF.elements |
  (('ROUND_HOLE' IN TYPEOF(it))) )) = 2);
WR3: SELF.elements[1].diameter.theoretical_size <>
  SELF.elements[2].diameter.theoretical_size;
WR4: NOT EXISTS(SELF.elements[1].change_in_diameter) AND
  EXISTS(SELF.elements[2].change_in_diameter);
END_ENTITY;

```

## 4.2.91 Curve\_with\_normal\_vector

The Curve\_with\_normal\_vector application object is defined by clause 4.8 of ISO 14649-10:2004. See 5.2.1.6.1 for additional discussion on the curve parameterization requirements defined by ISO 14649 on the basiccurve and surface\_normal data associated with a Curve\_with\_normal\_vector.

NOTE The ISO 14649 EXPRESS description for Curve\_with\_normal\_vector is shown below. Refer to ISO 14649-10 for the complete definition and explanation of usage.

```

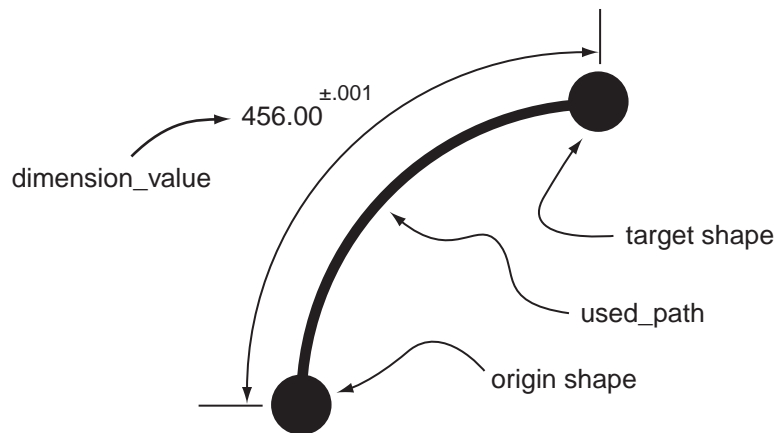
ENTITY curve_with_normal_vector;
  basiccurve: bounded_curve;
  surface_normal: bounded_curve;
END_ENTITY;

```

## 4.2.92 Curved\_distance\_dimension

A `Curved_distance_dimension` is a type of `Location_dimension` (see 4.2.187) that defines the arc length along a curve between two elements of the shape of a part.

NOTE This definition has been harmonized with the `Curved_distance_dimension` definitions in ISO 10303-1050 and ISO 10303-214, as well as the `Distance_along_curve_tolerance` definition in ISO 10303-224. Figure 8 illustrates a `Curved_distance_dimension`.



**Figure 8 — Curved\_distance\_dimension**

The data associated with a `Curved_distance_dimension` are the following:

— `used_path`.

### 4.2.92.1 used\_path

The `used_path` specifies a `Measurement_path` along which the `Curved_distance_dimension` is measured. See 4.3.12 for the application assertion.

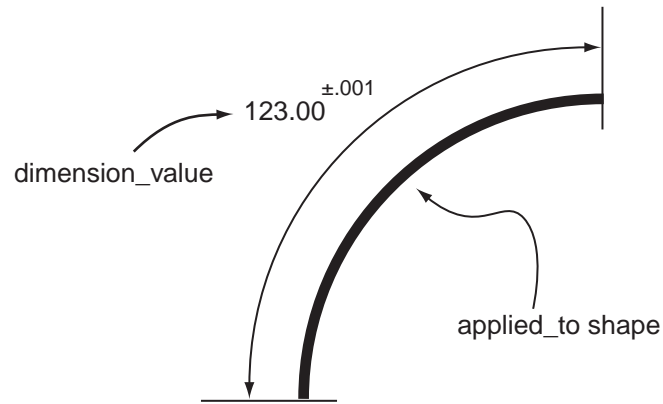
## 4.2.93 Curved\_size\_dimension

A `Curved_size_dimension` is a type of `Size_dimension` (see 4.2.313) that defines the allowable variation in the length of a curve shape element, as measured along the entire path of the curve.

NOTE This definition has been harmonized with the `Curved_size_dimension` definitions in ISO 10303-1050 and ISO 10303-214, as well as the `Curved_dimension_tolerance` definition in ISO 10303-224. Figure 9 illustrates a `Curved_size_dimension`.

## 4.2.94 Cutter\_contact\_trajectory

The `Cutter_contact_trajectory` application object is defined by clause 4.8 of ISO 14649-10:2004. This part of ISO 10303 adds the following information requirements.



**Figure 9 — Curved\_size\_dimension**

The data associated with a Cutter\_contact\_trajectory are the following:

- all of the data defined by ISO 14649-10, as modified below for the its\_toolaxis attributes;
- path\_maximum\_deviation;
- tool\_axis\_maximum\_deviation.

See 5.2.1.6.1 for additional discussion on the curve parameterization requirements defined by ISO 14649 on the basiccurve and its\_toolaxis data associated with a Cutter\_contact\_trajectory.

NOTE The ISO 14649 EXPRESS description for Cutter\_contact\_trajectory, as adapted by this part of ISO 10303, is shown below. Refer to ISO 14649-10 for the original definition and explanation of usage.

```

ENTITY cutter_contact_trajectory
  SUBTYPE OF (trajectory);
  basiccurve:          curve_with_surface_normal;
  its_toolaxis:        OPTIONAL bounded_curve;
  its_contact_type:    OPTIONAL contact_type;
  path_maximum_deviation:  OPTIONAL length_measure;      -- ADDED BY 10303-238
  tool_axis_maximum_deviation:  OPTIONAL plane_angle_measure; -- ADDED BY 10303-238
END_ENTITY;

TYPE curve_with_surface_normal = SELECT (bounded_pcurve, curve_with_normal_vector);
END_TYPE;

TYPE contact_type = ENUMERATION OF (side, front);
END_TYPE;

```

#### 4.2.94.1 its\_toolaxis

The its\_toolaxis parameter is defined by ISO 14649-10 to contain tilt and yaw angles, but this part of ISO 10303 modifies this requirement so that its\_toolaxis shall contain the IJK components of the tool axis vector, as is defined by the Cutter\_location\_trajectory its\_toolaxis parameter.



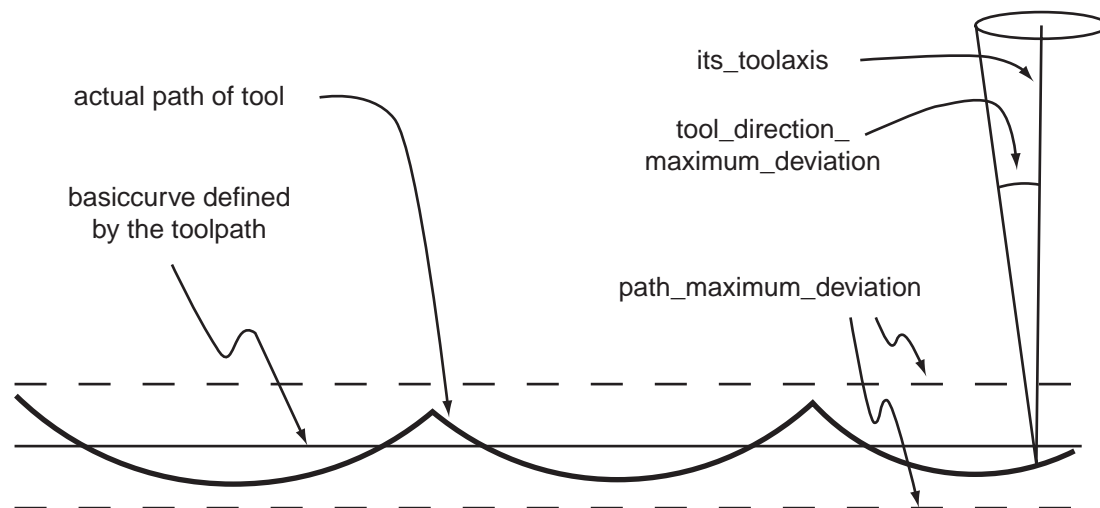
### 4.2.94.2 path\_maximum\_deviation

The `path_maximum_deviation` specifies a linear distance. If this distance is specified, the NC control shall not allow the physical motion of the cutter contact point during execution of the toolpath to exceed this distance from the basiccurve specified by the toolpath. The `path_maximum_deviation` need not be specified for a particular `Cutter_contact_trajectory`.

### 4.2.94.3 tool\_axis\_maximum\_deviation

The `tool_axis_maximum_deviation` specifies a plane angle. If this angle is specified, the NC control shall not allow the physical orientation of the tool axis during execution of the toolpath to exceed this angular distance from the `its_toolaxis` direction. The `tool_axis_maximum_deviation` need not be specified for a particular `Cutter_contact_trajectory`.

NOTE Figure 10 illustrates the range of deviations described by the `tool_direction_maximum_deviation` and `path_maximum_deviation` parameters. It is expected that an NC controller will adjust linearization tolerances (for 5-axis operation, as with the APT-CL LINTOL concept) as well as feed and acceleration rates to remain within the allowed deviations.



**Figure 10 — Toolpath deviation parameters**

### 4.2.95 Cutter\_location\_trajectory

The `Cutter_location_trajectory` application object is defined by clause 4.8 of ISO 14649-10:2004. This part of ISO 10303 adds the following information requirements.

The data associated with a `Cutter_location_trajectory` are the following:

- all of the data defined by ISO 14649-10, as modified below for the `surface_normal` attribute;
- `path_maximum_deviation`;
- `tool_axis_maximum_deviation`.

See 5.2.1.6.1 for additional discussion on the curve parameterization requirements defined by ISO 14649 on the `basiccurve`, `its_toolaxis`, and `surface_normal` data associated with a `Cutter_location_trajectory`.

NOTE The ISO 14649 EXPRESS description for `Cutter_location_trajectory`, as adapted by this part of ISO 10303, is shown below. Refer to ISO 14649-10 for the original definition and explanation of usage.

```
ENTITY cutter_location_trajectory
  SUBTYPE OF (trajectory);
  basiccurve:          bounded_curve;
  its_toolaxis:        OPTIONAL bounded_curve;
  surface_normal:     OPTIONAL bounded_curve;
  path_maximum_deviation:  OPTIONAL length_measure;    -- ADDED BY 10303-238
  tool_axis_maximum_deviation:  OPTIONAL plane_angle_measure; -- ADDED BY 10303-238
END_ENTITY;
```

### 4.2.95.1 surface\_normal

The `surface_normal` parameter is defined by ISO 14649-10 remains unchanged, but this part of ISO 10303 clarifies the contents of this parameter so that `surface_normal` shall contain the IJK components of the surface normal vector.

### 4.2.95.2 path\_maximum\_deviation

The `path_maximum_deviation` specifies a linear distance. If this distance is specified, the NC control shall not allow the physical motion of the cutter centre point during execution of the toolpath to exceed this distance from the `basiccurve` specified by the toolpath. The `path_maximum_deviation` need not be specified for a particular `Cutter_location_trajectory`.

### 4.2.95.3 tool\_axis\_maximum\_deviation

The `tool_axis_maximum_deviation` specifies a plane angle. If this angle is specified, the NC control shall not allow the physical orientation of the tool axis during execution of the toolpath to exceed this angular distance from the `its_toolaxis` direction. The `tool_axis_maximum_deviation` need not be specified for a particular `Cutter_location_trajectory`.

NOTE Figure 10 illustrates the range of deviations described by the `tool_direction_maximum_deviation` and `path_maximum_deviation` parameters.

## 4.2.96 Cutting\_component

The `Cutting_component` application object is defined by clause 4 of ISO 14649-111:—.

NOTE The ISO 14649 EXPRESS description for `Cutting_component` is shown below. Refer to ISO 14649-111 for the complete definition and explanation of usage.

```
ENTITY cutting_component;
  tool_functional_length: length_measure;
```

```

its_material:          OPTIONAL material;
expected_tool_life:   OPTIONAL time_measure;
its_technology:       OPTIONAL technology;
END_ENTITY;

```

### 4.2.97 Cutting\_edge\_properties

The Cutting\_edge\_properties application object is defined by clause 4 of ISO 14649-121:2005.

NOTE The ISO 14649 EXPRESS description for Cutting\_edge\_properties is shown below. Refer to ISO 14649-121 for the complete definition and explanation of usage.

```

ENTITY cutting_edge_properties;
  its_material:          OPTIONAL material;
  expected_tool_life:   OPTIONAL time_measure;
  its_technology:       OPTIONAL technology;
  cutting_edge_length:  OPTIONAL length_measure;
  tool_cutting_edge_angle:  OPTIONAL plane_angle_measure;
  tool_cutting_edge_angle_type:  OPTIONAL STRING;
  tool_included_angle:  OPTIONAL plane_angle_measure;
  corner_transitions:  LIST [0:?] OF corner_transition;
  maximum_side_cutting_depth:  OPTIONAL length_measure;
  maximum_end_cutting_depth:  OPTIONAL length_measure;
END_ENTITY;

```

### 4.2.98 Cutting\_in

The Cutting\_in application object is defined by clause 4.4 of ISO 14649-12:2005.

NOTE The ISO 14649 EXPRESS description for Cutting\_in is shown below. Refer to ISO 14649-12 for the complete definition and explanation of usage.

```

ENTITY cutting_in
  SUBTYPE OF (grooving);
WHERE
  WR1: NOT (EXISTS (SELF.allowance));
END_ENTITY;

```

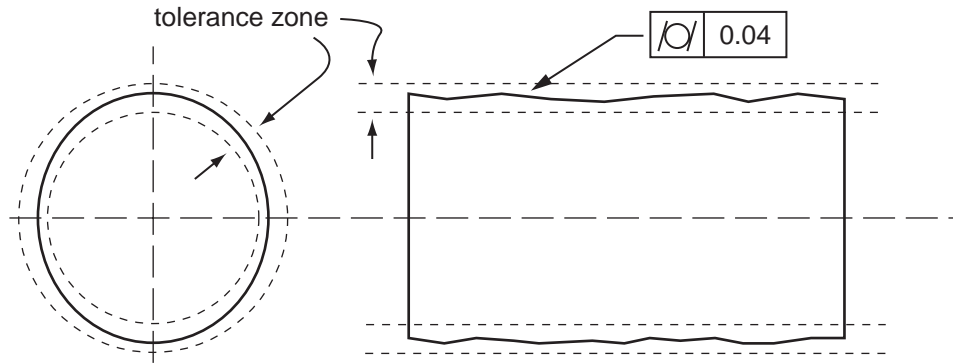
### 4.2.99 Cylindricity\_tolerance

A Cylindricity\_tolerance is a type of Geometric\_tolerance (see 4.2.156) that specifies a constraint on the amount a surface may deviate from being nominally cylindrical. The tolerance zone is limited by two coaxial cylinders, with a difference in radii of the tolerance value.

NOTE This definition has been harmonized with the Cylindricity\_tolerance definitions in ISO 10303-1051, ISO 10303-214, and ISO 10303-224. The definition is derived from clause 14.4 of ISO 1101:2004. Figure 11 illustrates a Cylindricity\_tolerance.

### 4.2.100 Datum

A Datum is a theoretically exact point, straight line, or plane used as a reference for locating and orienting tolerance zones.



**Figure 11 — Cylindricity\_tolerance**

NOTE The concept of datum for tolerancing is defined in ISO 5459.

#### 4.2.101 Datum\_defined\_by\_derived\_shape

A Datum\_defined\_by\_derived\_shape is type of both Single\_datum (see 4.2.312) and Derived\_geometry (see 4.2.107) that is established by a shape element that is derived from an existing aspect of the shape of a part.

NOTE The different types of derived shape elements are described by the Derived\_geometry type. The mapping specification in 5.1, represents this type as a complex instance of datum and derived\_shape\_aspect or a sub-type.

#### 4.2.102 Datum\_defined\_by\_feature

A Datum\_defined\_by\_feature is type of Single\_datum (see 4.2.312) that is established by an existing aspect of the shape of a part.

The data associated with a Datum\_defined\_by\_feature are the following:

- defined\_by.

##### 4.2.102.1 defined\_by

The defined\_by specifies the shape element that represents the Datum\_defined\_by\_feature. There shall be exactly one shape element that appears as defined\_by for a Datum\_defined\_by\_feature.

#### 4.2.103 Datum\_defined\_by\_targets

A Datum\_defined\_by\_targets is type of Single\_datum (see 4.2.312) that is established by a set of Datum\_target objects used to define a datum reference frame for a part.

NOTE Datums are established from a set of datum targets when the use of an entire feature would introduce excessive variations or lack of repeatability in measurements.

The data associated with a Datum\_defined\_by\_targets are the following:

- defined\_by.
- rule\_description;

#### **4.2.103.1 defined\_by**

The defined\_by specifies the set of Datum\_target objects that form the Datum\_defined\_by\_targets. See 4.3.13 for the application assertion.

#### **4.2.103.2 rule\_description**

The rule\_description specifies the type of datum that is formed by the Datum\_defined\_by\_targets. The rule\_description need not be specified for a particular Datum\_defined\_by\_targets.

**EXAMPLE** The rule\_description 'V-block' indicates that two Datum\_target objects on a cylindrical element are supposed to form the areas of contact in a V-shaped fixture.

### **4.2.104 Datum\_reference**

A Datum\_reference specifies the usage of a datum within the context of a geometric tolerance.

The data associated with a Datum\_reference are the following:

- precedence;
- referenced\_datum.

#### **4.2.104.1 precedence**

The precedence specifies the position of the referenced\_datum in a sequence of Datum objects when used to locate or orient a tolerance zone.

#### **4.2.104.2 referenced\_datum**

The referenced\_datum specifies the Datum to which the Datum\_reference applies. See 4.3.14 for the application assertion.

### **4.2.105 Datum\_target**

A Datum\_target is the identification of a portion of a feature, that is used in the construction of a Datum when it is not desired to use an entire feature nor a substantial region. A Datum\_target is a component of a Datum\_defined\_by\_targets.

**EXAMPLE** A cylindrical part is stabilized for measurement by resting it in a V block, thereby establishing a Datum consisting of two instances of Datum\_target, which are straight lines.

The data associated with a Datum\_target are the following:

- identifier.

#### 4.2.105.1 identifier

The identifier specifies a unique identification for the Datum\_target within a Datum\_defined\_by\_-targets.

#### 4.2.106 Defined\_thread

The Defined\_thread application object is defined by clause 4.5 of ISO 14649-10:2004.

NOTE The ISO 14649 EXPRESS description for Defined\_thread is shown below. Refer to ISO 14649-10 for the complete definition and explanation of usage.

```
ENTITY defined_thread
  SUBTYPE OF (thread);
  pitch_diameter:      length_measure;
  minor_diameter:     OPTIONAL length_measure;
  crest:               OPTIONAL length_measure;
END_ENTITY;
```

#### 4.2.107 Derived\_geometry

A Derived\_geometry defines a shape element that is derived from an existing aspect of the shape of a part for tolerancing purposes.

The data associated with a Derived\_geometry are the following:

- derived\_from;
- role.

##### 4.2.107.1 derived\_from

The derived\_from specifies the set of one or more shape elements from which the geometric element is derived.

##### 4.2.107.2 role

The role specifies the function of the Derived\_geometry. Where applicable the following values shall be used:

- apex: the derived geometry is an apex of a cone;
- centre of symmetry: the derived geometry is the centre of a symmetrical feature;
- extension: the derived geometry is the spatial extension of a feature;

- geometric alignment: the derived geometry is a geometric alignment of two features;
- geometric intersection: the derived geometry is a geometric intersection of two features;
- parallel offset: the derived geometry is a parallel offset to a feature;
- perpendicular to: the derived geometry is a perpendicular to a feature;
- tangent: the derived geometry is a tangent to a feature.

### 4.2.108 Descriptive\_parameter

The Descriptive\_parameter application object is defined by clause 4.4 of ISO 14649-10:2004.

NOTE The ISO 14649 EXPRESS description for Descriptive\_parameter is shown below. Refer to ISO 14649-10 for the complete definition and explanation of usage.

```
ENTITY descriptive_parameter
  SUBTYPE OF (property_parameter);
  descriptive_string:      text;
END_ENTITY;
```

### 4.2.109 Diagonal\_knurl

The Diagonal\_knurl application object is defined by clause 4.2 of ISO 14649-12:2005.

NOTE The ISO 14649 EXPRESS description for Diagonal\_knurl is shown below. Refer to ISO 14649-12 for the complete definition and explanation of usage.

```
ENTITY diagonal_knurl
  SUBTYPE OF (knurl);
  helix_angle : plane_angle_measure;
END_ENTITY;
```

### 4.2.110 Diameter\_size\_dimension

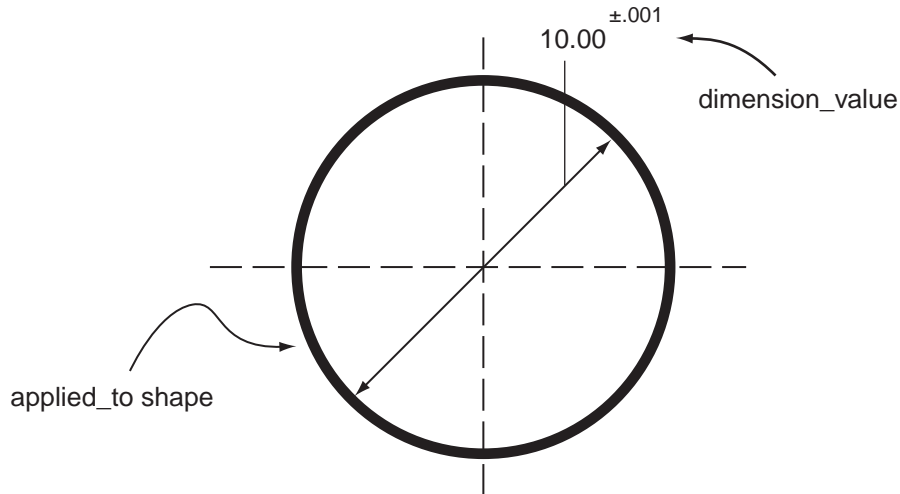
A Diameter\_size\_dimension is a type of Size\_dimension (see 4.2.313) that defines the allowable variation in the diameter of a circular, cylindrical, or spherical shape element.

NOTE This definition has been harmonized with the Diameter\_size\_dimension definitions in ISO 10303-1050 and ISO 10303-214, as well as the Diameter\_dimension\_tolerance definition in ISO 10303-224. Figure 12 illustrates a Diameter\_size\_dimension.

### 4.2.111 Diameter\_taper

The Diameter\_taper application object is defined by clause 4.5 of ISO 14649-10:2004.

NOTE The ISO 14649 EXPRESS description for Diameter\_taper is shown below. Refer to ISO 14649-10 for the complete definition and explanation of usage.



**Figure 12 — Diameter\_size\_dimension**

```
ENTITY diameter_taper;
  final_diameter: toleranced_length_measure;
END_ENTITY;
```

#### 4.2.112 Diamond\_knurl

The Diamond\_knurl application object is defined by clause 4.2 of ISO 14649-12:2005.

NOTE The ISO 14649 EXPRESS description for Diamond\_knurl is shown below. Refer to ISO 14649-12 for the complete definition and explanation of usage.

```
ENTITY diamond_knurl
  SUBTYPE OF (knurl);
  helix1_angle: plane_angle_measure;
  helix2_angle: OPTIONAL plane_angle_measure;
END_ENTITY;
```

#### 4.2.113 Display\_message

The Display\_message application object is defined by clause 4.6 of ISO 14649-10:2004.

NOTE The ISO 14649 EXPRESS description for Display\_message is shown below. Refer to ISO 14649-10 for the complete definition and explanation of usage.

```
ENTITY display_message
  SUBTYPE OF (nc_function);
  its_text: text;
END_ENTITY;
```

#### 4.2.114 Dovetail\_mill

The Dovetail\_mill application object is defined by clause 4 of ISO 14649-111:—.



NOTE The ISO 14649 EXPRESS description for Dovetail\_mill is shown below. Refer to ISO 14649-111 for the complete definition and explanation of usage.

```
ENTITY dovetail_mill
  SUBTYPE OF (milling_cutting_tool);
  included_angle: plane_angle_measure;
END_ENTITY;
```

### 4.2.115 Drilling

The Drilling application object is defined by clause 4 of ISO 14649-11:2004.

NOTE The ISO 14649 EXPRESS description for Drilling is shown below. Refer to ISO 14649-11 for the complete definition and explanation of usage.

```
ENTITY drilling
  SUBTYPE OF (drilling_operation);
END_ENTITY;
```

### 4.2.116 Drilling\_cutting\_tool

The Drilling\_cutting\_tool application object is defined by clause 4 of ISO 14649-111:—.

NOTE The ISO 14649 EXPRESS description for Drilling\_cutting\_tool is shown below. Refer to ISO 14649-111 for the complete definition and explanation of usage.

```
ENTITY drilling_cutting_tool
  SUPERTYPE OF (ONEOF(counterbore, countersink, spade_drill, spotdrill,
    step_drill, twist_drill))
  SUBTYPE OF (milling_machine_cutting_tool);
  point_angle: plane_angle_measure;
END_ENTITY;
```

### 4.2.117 Drilling\_operation

The Drilling\_operation application object is defined by clause 4 of ISO 14649-11:2004.

NOTE The ISO 14649 EXPRESS description for Drilling\_operation is shown below. Refer to ISO 14649-11 for the complete definition and explanation of usage.

```
ENTITY drilling_operation
  ABSTRACT SUPERTYPE OF (ONEOF(drilling, center_drilling, counter_sinking,
    multistep_drilling))
  SUBTYPE OF (drilling_type_operation);
END_ENTITY;
```

### 4.2.118 Drilling\_type\_operation

The Drilling\_type\_operation application object is defined by clause 4 of ISO 14649-11:2004.

NOTE The ISO 14649 EXPRESS description for Drilling\_type\_operation is shown below. Refer to ISO 14649-11 for the complete definition and explanation of usage.

```

ENTITY drilling_type_operation
  ABSTRACT SUPERTYPE OF (ONEOF(drilling_operation, boring_operation, back_boring,
    tapping, thread_drilling))
  SUBTYPE OF (milling_machining_operation);
  cutting_depth:           OPTIONAL length_measure;
  previous_diameter:      OPTIONAL length_measure;
  dwell_time_bottom:      OPTIONAL time_measure;
  feed_on_retract:        OPTIONAL positive_ratio_measure;
  its_machining_strategy: OPTIONAL drilling_type_strategy;
END_ENTITY;

```

### 4.2.119 Drilling\_type\_strategy

The Drilling\_type\_strategy application object is defined by clause 4 of ISO 14649-11:2004.

NOTE The ISO 14649 EXPRESS description for Drilling\_type\_strategy is shown below. Refer to ISO 14649-11 for the complete definition and explanation of usage.

```

ENTITY drilling_type_strategy;
  reduced_cut_at_start:  OPTIONAL positive_ratio_measure;
  reduced_feed_at_start: OPTIONAL positive_ratio_measure;
  depth_of_start:        OPTIONAL length_measure;
  reduced_cut_at_end:    OPTIONAL positive_ratio_measure;
  reduced_feed_at_end:   OPTIONAL positive_ratio_measure;
  depth_of_end:          OPTIONAL length_measure;
WHERE
  WR1: EXISTS(depth_of_start) OR
      NOT (EXISTS(reduced_cut_at_start) OR EXISTS(reduced_feed_at_start));
  WR2: EXISTS(depth_of_end) OR
      NOT (EXISTS(reduced_cut_at_end) OR EXISTS(reduced_feed_at_end));
END_ENTITY;

```

### 4.2.120 Edge\_round

The Edge\_round application object is defined by clause 4.5 of ISO 14649-10:2004. This part of ISO 10303 adds the following information requirements. See 5.2.1.3.7 for additional discussion on these information requirements.

NOTE 1 As defined by ISO 14649-10, an Edge\_round can only describe a transition between two features. For harmonization with ISO 10303-224 and other ISO 10303 parts, the following properties have been added so that an Edge\_round can also describe a transition between two sets of faces on the boundary representation of the workpiece.

The data associated with an Edge\_round are the following:

- all of the data defined by ISO 14649-10;
- edge\_round\_face;
- first\_face\_shape;
- second\_face\_shape.

NOTE 2 The ISO 14649 EXPRESS description for Edge\_round, as adapted by this part of ISO 10303, is shown below. Refer to ISO 14649-10 for the original definition and explanation of usage.

```
ENTITY edge_round
  SUBTYPE OF (transition_feature);
  radius:          toleranced_length_measure;
  first_offset_amount:  OPTIONAL toleranced_length_measure;
  second_offset_amount: OPTIONAL toleranced_length_measure;
  edge_round_face:    OPTIONAL SET [1:?] OF face; -- ADDED BY 10303-238
  first_face_shape:   OPTIONAL SET [1:?] OF face; -- ADDED BY 10303-238
  second_face_shape:  OPTIONAL SET [1:?] OF face; -- ADDED BY 10303-238
END_ENTITY;
```

#### 4.2.120.1 edge\_round\_face

The edge\_round\_face specifies the circular transition surface located between the first\_face\_shape and the second\_face\_shape surfaces. This is a set of one or more faces on the boundary representation of the workpiece. The edge\_round\_face need not be specified for a particular Edge\_round.

#### 4.2.120.2 first\_face\_shape

The first\_face\_shape specifies one of two surfaces the Edge\_round feature will transition between. This is a set of one or more faces on the boundary representation of the workpiece. The first\_face\_shape need not be specified for a particular Edge\_round.

#### 4.2.120.3 second\_face\_shape

The second\_face\_shape specifies the other surface the Edge\_round feature will transition between. This is a set of one or more faces on the boundary representation of the workpiece. The second\_face\_shape need not be specified for a particular Edge\_round.

### 4.2.121 Endmill

The Endmill application object is defined by clause 4 of ISO 14649-111:—.

NOTE The ISO 14649 EXPRESS description for Endmill is shown below. Refer to ISO 14649-111 for the complete definition and explanation of usage.

```
ENTITY endmill
  SUPERTYPE OF (ONEOF(ballnose_endmill, bullnose_endmill, profiled_end_mill))
  SUBTYPE OF (milling_cutting_tool);
  tool_cutting_edge_angle: plane_angle_measure;
END_ENTITY;
```

### 4.2.122 Exchange\_pallet

The Exchange\_pallet application object is defined by clause 4 of ISO 14649-11:2004.

NOTE The ISO 14649 EXPRESS description for Exchange\_pallet is shown below. Refer to ISO 14649-11 for the complete definition and explanation of usage.

```
ENTITY exchange_pallet
  SUBTYPE OF (nc_function);
END_ENTITY;
```

### 4.2.123 Executable

The Executable application object is defined by clause 4.6 of ISO 14649-10:2004.

NOTE The ISO 14649 EXPRESS description for Executable is shown below. Refer to ISO 14649-10 for the complete definition and explanation of usage.

```
ENTITY executable
  ABSTRACT SUPERTYPE OF (ONEOF( workingstep, nc_function, program_structure));
  its_id: identifier;
END_ENTITY;
```

### 4.2.124 Explicit\_strategy

The Explicit\_strategy application object is defined by clause 4 of ISO 14649-11:2004.

NOTE The ISO 14649 EXPRESS description for Explicit\_strategy is shown below. Refer to ISO 14649-11 for the complete definition and explanation of usage.

```
ENTITY explicit_strategy
  SUBTYPE OF (two5D_milling_strategy);
END_ENTITY;
```

### 4.2.125 Explicit\_turning\_strategy

The Explicit\_turning\_strategy application object is defined by clause 4.4 of ISO 14649-12:2005.

NOTE The ISO 14649 EXPRESS description for Explicit\_turning\_strategy is shown below. Refer to ISO 14649-12 for the complete definition and explanation of usage.

```
ENTITY explicit_turning_strategy
  SUBTYPE OF (turning_machining_strategy);
END_ENTITY;
```

### 4.2.126 Extended\_NC\_function

An Extended\_NC\_function is a type of NC\_function which specifies a manufacturing or handling operation which does not involve the interpolation of axes and for which no other more specific type of NC\_function exists. This shall not be used if equivalent machine behavior can be achieved using other capabilities of this part of ISO 10303.

The data associated with an Extended\_NC\_function are the following:

- description.

### 4.2.126.1 description

The description specifies a string value which identifies the function.

### 4.2.127 Externally\_defined\_representation

An Externally\_defined\_representation is used to identify a piece of product data whose definition is provided within an external specification or document.

NOTE This definition has been harmonized with the Externally\_defined\_representation definitions in ISO 10303-224 and ISO 10303-240.

The data associated with a Externally\_defined\_representation are the following:

- identified\_by;
- location;
- placement.

#### 4.2.127.1 identified\_by

The identified\_by specifies the Library\_part\_assignment object which describes the part being referenced, that is contained in an external library. See 4.3.15 for the application assertion.

#### 4.2.127.2 location

The location specifies the orientation of the external product data within the geometric domain of the product data of this part of ISO 10303. A location need not be specified for a particular Externally\_defined\_representation.

#### 4.2.127.3 placement

The placement specifies the positioning of the external product data within the geometric domain of the product data of this part of ISO 10303. A placement need not be specified for a particular Externally\_defined\_representation.

### 4.2.128 Externally\_defined\_size\_dimension

An Externally\_defined\_size\_dimension is a type of Size\_dimension (see 4.2.313) that defines the allowable variation in a size dimension whose definition is provided by an external specification.

NOTE This definition has been harmonized with the Externally\_defined\_size\_dimension definitions in ISO 10303-1050, ISO 10303-214, and ISO 10303-224.

The data associated with an `Externally_defined_size_dimension` are the following:

- `defining_document`;
- `name`;
- `used_path`.

#### **4.2.128.1 defining\_document**

The `defining_document` specifies a document that contains information about the type of dimension.

#### **4.2.128.2 name**

The `name` specifies the label by which the `Externally_defined_size_dimension` is known.

#### **4.2.128.3 used\_path**

The `used_path` specifies a `Measurement_path` along which the `Externally_defined_size_dimension` is measured. The `used_path` need not be specified for a particular `Externally_defined_size_dimension`. See 4.3.16 for the application assertion.

### **4.2.129 Facemill**

The Facemill application object is defined by clause 4 of ISO 14649-111:—.

NOTE The ISO 14649 EXPRESS description for Facemill is shown below. Refer to ISO 14649-111 for the complete definition and explanation of usage.

```
ENTITY facemill
  SUBTYPE OF (milling_cutting_tool);
  tool_cutting_edge_angle: plane_angle_measure;
END_ENTITY;
```

### **4.2.130 Facing**

The Facing application object is defined by clause 4.4 of ISO 14649-12:2005.

NOTE The ISO 14649 EXPRESS description for Facing is shown below. Refer to ISO 14649-12 for the complete definition and explanation of usage.

```
ENTITY facing
  ABSTRACT SUPERTYPE OF (ONEOF(facing_rough, facing_finish))
  SUBTYPE OF (turning_machining_operation);
  allowance: OPTIONAL length_measure;
END_ENTITY;
```

### 4.2.131 Facing\_finish

The Facing\_finish application object is defined by clause 4.4 of ISO 14649-12:2005.

NOTE The ISO 14649 EXPRESS description for Facing\_finish is shown below. Refer to ISO 14649-12 for the complete definition and explanation of usage.

```
ENTITY facing_finish
  SUBTYPE OF (facing);
END_ENTITY;
```

### 4.2.132 Facing\_rough

The Facing\_rough application object is defined by clause 4.4 of ISO 14649-12:2005.

NOTE The ISO 14649 EXPRESS description for Facing\_rough is shown below. Refer to ISO 14649-12 for the complete definition and explanation of usage.

```
ENTITY facing_rough
  SUBTYPE OF (facing);
WHERE
  WR1: EXISTS(SELF.allowance) AND (SELF.allowance >= 0.0);
END_ENTITY;
```

### 4.2.133 Feedstop

The Feedstop application object is defined by clause 4.8 of ISO 14649-10:2004.

NOTE The ISO 14649 EXPRESS description for Feedstop is shown below. Refer to ISO 14649-10 for the complete definition and explanation of usage.

```
ENTITY feedstop
  SUBTYPE OF (toolpath);
  dwell: time_measure;
END_ENTITY;
```

### 4.2.134 Five\_axes\_const\_tilt\_yaw

The Five\_axes\_const\_tilt\_yaw application object is defined by clause 4 of ISO 14649-11:2004.

NOTE The ISO 14649 EXPRESS description for Five\_axes\_const\_tilt\_yaw is shown below. Refer to ISO 14649-11 for the complete definition and explanation of usage.

```
ENTITY five_axes_const_tilt_yaw
  SUBTYPE OF (tool_direction_for_milling);
  tilt_angle : plane_angle_measure;
  yaw_angle  : plane_angle_measure;
END_ENTITY;
```

### 4.2.135 Five\_axes\_var\_tilt\_yaw

The Five\_axes\_var\_tilt\_yaw application object is defined by clause 4 of ISO 14649-11:2004.

NOTE The ISO 14649 EXPRESS description for Five\_axes\_var\_tilt\_yaw is shown below. Refer to ISO 14649-11 for the complete definition and explanation of usage.

```
ENTITY five_axes_var_tilt_yaw
  SUBTYPE OF (tool_direction_for_milling);
END_ENTITY;
```

### 4.2.136 Flat\_hole\_bottom

The Flat\_hole\_bottom application object is defined by clause 4.5 of ISO 14649-10:2004.

NOTE The ISO 14649 EXPRESS description for Flat\_hole\_bottom is shown below. Refer to ISO 14649-10 for the complete definition and explanation of usage.

```
ENTITY flat_hole_bottom
  SUBTYPE OF (blind_bottom_condition);
END_ENTITY;
```

### 4.2.137 Flat\_slot\_end\_type

The Flat\_slot\_end\_type application object is defined by clause 4.5 of ISO 14649-10:2004.

NOTE The ISO 14649 EXPRESS description for Flat\_slot\_end\_type is shown below. Refer to ISO 14649-10 for the complete definition and explanation of usage.

```
ENTITY flat_slot_end_type
  SUBTYPE OF (slot_end_type);
  corner_radius1: toleranced_length_measure;
  corner_radius2: toleranced_length_measure;
END_ENTITY;
```

### 4.2.138 Flat\_with\_radius\_hole\_bottom

The Flat\_with\_radius\_hole\_bottom application object is defined by clause 4.5 of ISO 14649-10:2004.

NOTE The ISO 14649 EXPRESS description for Flat\_with\_radius\_hole\_bottom is shown below. Refer to ISO 14649-10 for the complete definition and explanation of usage.

```
ENTITY flat_with_radius_hole_bottom
  SUBTYPE OF (blind_bottom_condition);
  corner_radius: toleranced_length_measure;
END_ENTITY;
```



### 4.2.139 Flatness\_tolerance

A Flatness\_tolerance is a type of Geometric\_tolerance (see 4.2.156) that specifies a constraint on the amount a surface is allowed to deviate from being flat. All points of the actual surface shall lie between two parallel planes that are a distance apart equal to the specified tolerance.

NOTE This definition has been harmonized with the Flatness\_tolerance definitions in ISO 10303-1051, ISO 10303-214, and ISO 10303-224. The definition is derived from clause 14.2 of ISO 1101:2004. Figure 13 illustrates a Flatness\_tolerance.

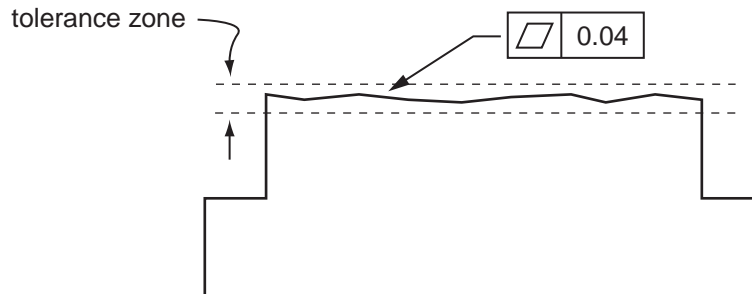


Figure 13 — Flatness\_tolerance

### 4.2.140 Freeform\_finish\_milling

A Freeform\_finish\_milling is a type of Freeform\_operation that specifies a finishing operation.

NOTE When specifying a freeform milling operation, particularly with an associated toolpath, the Freeform\_rough\_milling and Freeform\_finish\_milling subtypes can be used to indicate whether the operation is used for roughing or finishing. Some CNC controls can provide important efficiency gains when provided with this information.

### 4.2.141 Freeform\_operation

The Freeform\_operation application object is defined by clause 4 of ISO 14649-11:2004.

NOTE The ISO 14649 EXPRESS description for Freeform\_operation is shown below. Refer to ISO 14649-11 for the complete definition and explanation of usage.

```
ENTITY freeform_operation
  SUBTYPE OF (milling_type_operation);
  its_machining_strategy: OPTIONAL freeform_strategy;
END_ENTITY;
```

### 4.2.142 Freeform\_rough\_milling

A Freeform\_rough\_milling is a type of Freeform\_operation that specifies a roughing operation.

### 4.2.143 Freeform\_strategy

The Freeform\_strategy application object is defined by clause 4 of ISO 14649-11:2004.

NOTE The ISO 14649 EXPRESS description for Freeform\_strategy is shown below. Refer to ISO 14649-11 for the complete definition and explanation of usage.

```

ENTITY freeform_strategy
  ABSTRACT SUPERTYPE OF (ONEOF(uv_strategy, plane_cc_strategy, plane_cl_strategy,
    leading_line_strategy));
  pathmode:          pathmode_type;
  cutmode:           cutmode_type;
  its_milling_tolerances: tolerances;
  stepover:          OPTIONAL length_measure;
END_ENTITY;

TYPE pathmode_type = ENUMERATION OF (forward, zigzag);
END_TYPE;

TYPE cutmode_type = ENUMERATION OF (climb, conventional);
END_TYPE;

```

### 4.2.144 General\_closed\_profile

The General\_closed\_profile application object is defined by clause 4.5 of ISO 14649-10:2004. This part of ISO 10303 adds the following information requirements.

The data associated with a General\_closed\_profile are the following:

- all of the data defined by ISO 14649-10, as modified below for the closed\_profile\_shape attribute.

NOTE The ISO 14649 EXPRESS description for General\_closed\_profile, as adapted by this part of ISO 10303, is shown below. Refer to ISO 14649-10 for the original definition and explanation of usage.

```

ENTITY general_closed_profile
  SUBTYPE OF(closed_profile);
  closed_profile_shape: path_shape_item; -- RELAXED BY 10303-238
END_ENTITY;

TYPE path_shape_item = SELECT (bounded_curve, edge_curve, path);
END_TYPE;

```

#### 4.2.144.1 closed\_profile\_shape

The closed\_profile\_shape parameter is defined by ISO 14649-10 to be of type bounded\_curve, but this part of ISO 10303 relaxes this requirement so that closed\_profile\_shape may also be of type edge\_curve or path.

NOTE This relaxation harmonizes the General\_closed\_profile definition in ISO 14649-10 with the definitions in ISO 10303-224 and other ISO 10303 parts that permit the use of bounded\_curve, edge\_curve, or path to describe profile shape. These additional types allow profiles to be described using edge and path elements already present in the advanced brep shape of a workpiece.

### 4.2.145 General\_outside\_profile

The General\_outside\_profile application object is defined by clause 4.5 of ISO 14649-10:2004.

NOTE The ISO 14649 EXPRESS description for General\_outside\_profile is shown below. Refer to ISO 14649-10 for the complete definition and explanation of usage.

```
ENTITY general_outside_profile
  SUBTYPE OF (profile_feature);
  feature_boundary: profile;
END_ENTITY;
```

### 4.2.146 General\_path

The General\_path application object defined by clause 4.5 of ISO 14649-10:2004. This part of ISO 10303 adds the following information requirements.

The data associated with a General\_path are the following:

- all of the data defined by ISO 14649-10, as modified below for the swept\_path attribute.

NOTE The ISO 14649 EXPRESS description for General\_path, as adapted by this part of ISO 10303, is shown below. Refer to ISO 14649-10 for the original definition and explanation of usage.

```
ENTITY general_path
  SUBTYPE OF (travel_path);
  (* see general_closed_profile for description of path_shape_item *)
  swept_path: path_shape_item; -- RELAXED BY 10303-238
END_ENTITY;
```

#### 4.2.146.1 swept\_path

The swept\_path parameter is defined by ISO 14649-10 to be of type bounded\_curve, but this part of ISO 10303 relaxes this requirement so that swept\_path may also be of type edge\_curve or path.

NOTE This relaxation harmonizes the General\_path definition in ISO 14649-10 with the definitions in ISO 10303-224 and other ISO 10303 parts that permit the use of bounded\_curve, edge\_curve, or path to describe travel path shape. These additional types allow travel paths to be described using edge and path elements already present in the advanced brep shape of a workpiece.

### 4.2.147 General\_pattern

The General\_pattern application object is defined by clause 4.5 of ISO 14649-10:2004.

NOTE The ISO 14649 EXPRESS description for General\_pattern is shown below. Refer to ISO 14649-10 for the complete definition and explanation of usage.

```
ENTITY general_pattern
  SUBTYPE OF (replicate_feature);
  replicate_locations: LIST [2:?] OF axis2_placement_3d;
END_ENTITY;
```

## 4.2.148 General\_pocket\_bottom\_condition

The General\_pocket\_bottom\_condition application object is defined by clause 4.5 of ISO 14649-10:2004.

NOTE The ISO 14649 EXPRESS description for General\_pocket\_bottom\_condition is shown below. Refer to ISO 14649-10 for the complete definition and explanation of usage.

```
ENTITY general_pocket_bottom_condition
  SUBTYPE OF (pocket_bottom_condition);
  shape:          region;
WHERE
  WR1: SIZEOF(shape\manufacturing_feature.its_operations) = 0;
END_ENTITY;
```

## 4.2.149 General\_profile

The General\_profile application object defined by clause 4.5 of ISO 14649-10:2004. This part of ISO 10303 adds the following information requirements.

The data associated with a General\_profile are the following:

- all of the data defined by ISO 14649-10, as modified below for the its\_profile attribute.

NOTE The ISO 14649 EXPRESS description for General\_profile, as adapted by this part of ISO 10303, is shown below. Refer to ISO 14649-10 for the original definition and explanation of usage.

```
ENTITY general_profile
  SUBTYPE OF (open_profile);
  (* see general_closed_profile for description of path_shape_item *)
  its_profile:      path_shape_item; -- RELAXED BY 10303-238
END_ENTITY;
```

### 4.2.149.1 its\_profile

The its\_profile parameter is defined by ISO 14649-10 to be of type bounded\_curve, but this part of ISO 10303 relaxes this requirement so that its\_profile may also be of type edge\_curve or path.

NOTE This relaxation harmonizes the General\_profile definition in ISO 14649-10 with the definitions in ISO 10303-224 and other ISO 10303 parts that permit the use of bounded\_curve, edge\_curve, or path to describe profile shape. These additional types allow profiles to be described using edge and path elements already present in the advanced brep shape of a workpiece.

## 4.2.150 General\_profile\_floor

The General\_profile\_floor application object is defined by clause 4.5 of ISO 14649-10:2004.

NOTE The ISO 14649 EXPRESS description for `General_profile_floor` is shown below. Refer to ISO 14649-10 for the complete definition and explanation of usage.

```
ENTITY general_profile_floor
  SUBTYPE OF (profile_floor);
  floor :          face;
END_ENTITY;
```

## 4.2.151 General\_property

A `General_property` is a characteristic associated with the physical structure or integrity of an element of a part. Each `General_property` is either a `Material_property` (see 4.2.201), a `Part_property` (see 4.2.232), a `Process_property` (see 4.2.261), or a `Surface_property` (see 4.2.330).

NOTE This definition is based on the `Property` definitions in ISO 10303-224 and ISO 10303-240.

The data associated with a `General_property` are the following:

- description;
- owner;
- specifications;
- related\_properties.

### 4.2.151.1 description

The description specifies a word or group of words by which a property is commonly referred.

### 4.2.151.2 owner

The owner specifies the `Workpiece` object or shape element to which the `General_property` applies. See 4.3.19 for the application assertion.

### 4.2.151.3 specifications

The specifications specifies the set of `Specification` objects that have additional information about the `General_property`. The specifications need not be specified for a particular `General_property`. See 4.3.18 for the application assertion.

### 4.2.151.4 related\_properties

The `related_properties` specifies the set of `General_property` objects that are associated with a `General_property`. The `related_properties` need not be specified for a particular `General_property`. See 4.3.17 for the application assertion.

### 4.2.152 General\_revolution

The General\_revolution application object is defined by clause 4.2 of ISO 14649-12:2005.

NOTE The ISO 14649 EXPRESS description for General\_revolution is shown below. Refer to ISO 14649-12 for the complete definition and explanation of usage.

```
ENTITY general_revolution
  SUBTYPE OF (revolved_feature);
  outer_edge_profile : general_profile;
END_ENTITY;
```

### 4.2.153 General\_shape\_profile

The General\_shape\_profile application object is defined by clause 4.5 of ISO 14649-10:2004.

NOTE The ISO 14649 EXPRESS description for General\_shape\_profile is shown below. Refer to ISO 14649-10 for the complete definition and explanation of usage.

```
ENTITY general_shape_profile
  SUBTYPE OF (shape_profile);
  profile_boundary : profile;
END_ENTITY;
```

### 4.2.154 General\_turning\_tool

The General\_turning\_tool application object is defined by clause 4 of ISO 14649-121:2005.

NOTE The ISO 14649 EXPRESS description for General\_turning\_tool is shown below. Refer to ISO 14649-121 for the complete definition and explanation of usage.

```
ENTITY general_turning_tool
  SUBTYPE OF (turning_machine_cutting_tool);
END_ENTITY;
```

### 4.2.155 Geometric\_dimension

A Geometric\_dimension is the specification of size of an element of a shape, or a displacement of one shape element relative to another shape element.

NOTE This definition has been harmonized with the Geometric\_dimension definitions in ISO 10303-1050 and ISO 10303-214, as well as the Dimensional\_tolerance definition in ISO 10303-224.

The data associated with a Geometric\_dimension are the following:

- dimension\_value;
- id;
- notes.

### 4.2.155.1 dimension\_value

The dimension\_value specifies a Value\_with\_tolerance or Value\_range which describes the size of the element or of the distance between the two elements, as well as the total amount by which that value is permitted to vary. See 4.3.20 and 4.3.21 for the application assertion.

### 4.2.155.2 id

The id specifies the string identifier of the Geometric\_dimension.

### 4.2.155.3 notes

The notes specifies a set of one or more string values that provide additional information about the Geometric\_dimension. The notes field need not be specified for a particular Geometric\_dimension. Where applicable the following values shall be used:

- auxiliary: the dimension is for information purposes only. The dimension\_value shall be a single numerical value without limitation;
- theoretical: the dimension is theoretically exact. The dimension\_value shall be a single numerical value without limitation;

Any other string value shall indicate a qualifying note.

## 4.2.156 Geometric\_tolerance

A Geometric\_tolerance is a specification of the allowable deviation of shape characteristics as defined in ISO 1101.

NOTE This definition has been harmonized with the Geometric\_tolerance definitions in ISO 10303-1050, ISO 10303-214, and ISO 10303-224.

The data associated with a Geometric\_tolerance are the following:

- applied\_to;
- modification;
- name;
- qualifying\_note;
- segment\_size;
- significant\_digits;
- tolerance\_value.

### **4.2.156.1 applied\_to**

The `applied_to` specifies the shape element to which the `Geometric_tolerance` applies.

### **4.2.156.2 modification**

The `modification` specifies the `Tolerance_condition` that is associated with the `Geometric_tolerance`. The `modification` need not be specified for a particular `Geometric_tolerance`. See 4.3.22 for the application assertion.

### **4.2.156.3 name**

The `name` specifies the word or group of words by which the `Geometric_tolerance` is referred to. The `name` need not be specified for a particular `Geometric_tolerance`.

### **4.2.156.4 qualifying\_note**

The `qualifying_note` specifies text that provides additional information about the `Geometric_tolerance`. The `qualifying_note` need not be specified for a particular `Geometric_tolerance`.

EXAMPLE 'not concave' and 'boundary' are examples of a qualifying note.

### **4.2.156.5 segment\_size**

The `segment_size` specifies a length of a segment that constrains how the tolerance applies. All along any segment of this size, taken on the toleranced element, the toleranced element shall conform to the tolerance. The `segment_size` need not be specified for a particular `Geometric_tolerance`.

### **4.2.156.6 significant\_digits**

The `significant_digits` specify the number of decimal digits indicating the accuracy of the tolerance value. The `significant_digits` need not be specified for a particular `Geometric_tolerance`.

### **4.2.156.7 tolerance\_value**

The `tolerance_value` specifies the value of the width of the tolerance zone. The meaning of this value will depend on the standard used for the interpretation of the geometric tolerance.

## **4.2.157 Geometric\_tolerance\_relationship**

A `Geometric_tolerance_relationship` specifies a relationship between two instances of `Geometric_tolerance`.



NOTE This definition has been harmonized with the `Geometric_tolerance_relationship` definitions in ISO 10303-1050 and ISO 10303-214, as well as the `Geometric_tolerance_precedence_relationship` definition in ISO 10303-224.

The data associated with a `Geometric_tolerance_relationship` are the following:

- `relating`;
- `related`;
- `relation_type`.

#### **4.2.157.1 relating**

The `relating` specifies one of the instances of `Geometric_tolerance` that is a part of the relationship. See 4.3.23 for the application assertion.

NOTE The semantics of this attribute are defined by the attribute `relation_type`.

#### **4.2.157.2 related**

The `related` specifies one of the instances of `Geometric_tolerance` that is a part of the relationship. See 4.3.24 for the application assertion.

NOTE The semantics of this attribute are defined by the attribute `relation_type`.

#### **4.2.157.3 relation\_type**

The `relation_type` specifies the meaning of the relationship. Where applicable, the following values shall be used:

- `precedence`: the relating `Geometric_tolerance` is of higher priority than the related;
- `simultaneity`: the relating and the related `Geometric_tolerance` shall be met simultaneously, that is, in the same actual datum reference frame.

### **4.2.158 Groove**

The Groove application object is defined by clause 4.2 of ISO 14649-12:2005.

NOTE The ISO 14649 EXPRESS description for Groove is shown below. Refer to ISO 14649-12 for the complete definition and explanation of usage.

```
ENTITY groove
  SUBTYPE OF (revolved_feature);
  sweep : open_profile;
END_ENTITY;
```

## 4.2.159 Grooving

The Grooving application object is defined by clause 4.4 of ISO 14649-12:2005.

NOTE The ISO 14649 EXPRESS description for Grooving is shown below. Refer to ISO 14649-12 for the complete definition and explanation of usage.

```
ENTITY grooving
  ABSTRACT SUPERTYPE OF (ONEOF(grooving_rough, grooving_finish, cutting_in))
  SUBTYPE OF (turning_machining_operation);
  dwell: OPTIONAL dwell_select;
  allowance: OPTIONAL length_measure;
END_ENTITY;
```

## 4.2.160 Grooving\_finish

The Grooving\_finish application object is defined by clause 4.4 of ISO 14649-12:2005.

NOTE The ISO 14649 EXPRESS description for Grooving\_finish is shown below. Refer to ISO 14649-12 for the complete definition and explanation of usage.

```
ENTITY grooving_finish
  SUBTYPE OF (grooving);
END_ENTITY;
```

## 4.2.161 Grooving\_rough

The Grooving\_rough application object is defined by clause 4.4 of ISO 14649-12:2005.

NOTE The ISO 14649 EXPRESS description for Grooving\_rough is shown below. Refer to ISO 14649-12 for the complete definition and explanation of usage.

```
ENTITY grooving_rough
  SUBTYPE OF (grooving);
  WHERE
    WR1: EXISTS(SELF.allowance) AND (SELF.allowance >= 0.0);
END_ENTITY;
```

## 4.2.162 Grooving\_strategy

The Grooving\_strategy application object is defined by clause 4.4 of ISO 14649-12:2005.

NOTE The ISO 14649 EXPRESS description for Grooving\_strategy is shown below. Refer to ISO 14649-12 for the complete definition and explanation of usage.

```
ENTITY grooving_strategy
  SUPERTYPE OF (multistep_grooving_strategy)
  SUBTYPE OF (turning_machining_strategy);
  grooving_direction: OPTIONAL direction;
  travel_distance:    OPTIONAL length_measure;
END_ENTITY;
```

## 4.2.163 Grooving\_tool

The Grooving\_tool application object is defined by clause 4 of ISO 14649-121:2005.

NOTE The ISO 14649 EXPRESS description for Grooving\_tool is shown below. Refer to ISO 14649-121 for the complete definition and explanation of usage.

```
ENTITY grooving_tool
  SUBTYPE OF (turning_machine_cutting_tool);
  cutting_width:          length_measure;
  maximum_grooving_depth: length_measure;
  corner_radius:         OPTIONAL length_measure;
  maximum_axial_grooving_diameter: OPTIONAL length_measure;
  minimum_axial_grooving_diameter: OPTIONAL length_measure;
END_ENTITY;
```

## 4.2.164 Hardness

A Hardness is the resistance of a material to deformation by external forces.

NOTE This definition has been harmonized with the Hardness definitions in ISO 10303-224 and ISO 10303-240.

The data associated with a Hardness are the following:

- high\_value;
- low\_value;
- nominal;
- scale.

### 4.2.164.1 high\_value

The high\_value specifies the highest allowed value of hardness for a specific material type. The high\_value need not be specified for a particular Hardness.

### 4.2.164.2 low\_value

The low\_value specifies the lowest allowed value of hardness for a specific material type. The low\_value need not be specified for a particular Hardness.

### 4.2.164.3 nominal

The nominal specifies the nominal value of hardness for a specific material type.

#### 4.2.164.4 scale

The scale specifies the method for measuring hardness values. Where applicable, the following values shall be used:

- brinell: The Hardness is measured according to the Brinell method;
- rockwell: The Hardness is measured according to the Rockwell method;
- vickers: The Hardness is measured according to the Vickers method.

#### 4.2.165 Height\_size\_dimension

A Height\_size\_dimension is a type of Size\_dimension (see 4.2.313) that defines the allowable variation in the height of an element of the product shape.

NOTE This definition has been harmonized with the Height\_size\_dimension definitions in ISO 10303-1050 and ISO 10303-214, as well as the Height\_dimension definition in ISO 10303-224.

The data associated with a Height\_size\_dimension are the following:

- used\_path.

#### 4.2.165.1 used\_path

The used\_path specifies a Measurement\_path along which the Height\_size\_dimension is measured. The used\_path need not be specified for a particular Height\_size\_dimension. See 4.3.25 for the application assertion.

#### 4.2.166 Hole\_bottom\_condition

The Hole\_bottom\_condition application object is defined by clause 4.5 of ISO 14649-10:2004.

NOTE The ISO 14649 EXPRESS description for Hole\_bottom\_condition is shown below. Refer to ISO 14649-10 for the complete definition and explanation of usage.

```
ENTITY hole_bottom_condition
  ABSTRACT SUPERTYPE OF (ONEOF (blind_bottom_condition, through_bottom_condition));
END_ENTITY;
```

#### 4.2.167 If\_statement

The If\_statement application object is defined by clause 4.6 of ISO 14649-10:2004.

NOTE The ISO 14649 EXPRESS description for If\_statement is shown below. Refer to ISO 14649-10 for the complete definition and explanation of usage.

```
ENTITY if_statement
```

```

SUBTYPE OF (program_structure);
condition:          boolean_expression;
true_branch:        executable;
false_branch:       OPTIONAL executable;
END_ENTITY;

```

## 4.2.168 In\_process\_geometry

The `In_process_geometry` application object is defined by clause 4.4 of ISO 14649-10:2004. This part of ISO 10303 adds the following information requirements.

NOTE 1 This modifications below allow the use of shape representation types supported by other APs. In particular, the integrated representation allows the use of shapes described by AIC 501 (edge-based wireframe), AIC 502 (shell-based wireframe), AIC 507 (geometrically-bounded surfaces), AIC 508 (non-manifold surfaces), AIC 509 (manifold surfaces), AIC 510 (geometrically-bounded wireframe), and AIC 512 (faceted brep), as well as the original AIC 514 (advanced brep) descriptions.

The data associated with a `In_process_geometry` are the following:

- all of the data defined by ISO 14649-10, as modified below for the `as_is`, `to_be` and removal attributes;

NOTE 2 The ISO 14649 EXPRESS description for `In_process_geometry`, as adapted by this part of ISO 10303, is shown below. Refer to ISO 14649-10 for the original definition and explanation of usage.

```

ENTITY in_process_geometry;
  as_is:    OPTIONAL shape_representation;    -- RELAXED BY 10303-238
  to_be:    OPTIONAL shape_representation;    -- RELAXED BY 10303-238
  removal:  OPTIONAL shape_representation;    -- RELAXED BY 10303-238
WHERE
  WR1: EXISTS (as_is) OR EXISTS (to_be) OR EXISTS (removal);
END_ENTITY;

```

### 4.2.168.1 as\_is

The `as_is` parameter is defined by ISO 14649-10 to be of type `advanced_brep_shape_representation`, but this part of ISO 10303 relaxes this requirement so that `as_is` shall be of the more general type `shape_representation`.

### 4.2.168.2 removal

The `removal` parameter is defined by ISO 14649-10 to be of type `advanced_brep_shape_representation`, but this part of ISO 10303 relaxes this requirement so that `removal` shall be of the more general type `shape_representation`.

### 4.2.168.3 to\_be

The `to_be` parameter is defined by ISO 14649-10 to be of type `advanced_brep_shape_representation`, but this part of ISO 10303 relaxes this requirement so that `to_be` shall be of the more general type `shape_representation`.

### 4.2.169 Index\_pallet

The Index\_pallet application object is defined by clause 4 of ISO 14649-11:2004.

NOTE The ISO 14649 EXPRESS description for Index\_pallet is shown below. Refer to ISO 14649-11 for the complete definition and explanation of usage.

```
ENTITY index_pallet
  SUBTYPE OF (nc_function);
  its_index:          INTEGER;
END_ENTITY;
```

### 4.2.170 Index\_table

The Index\_table application object is defined by clause 4 of ISO 14649-11:2004.

NOTE The ISO 14649 EXPRESS description for Index\_table is shown below. Refer to ISO 14649-11 for the complete definition and explanation of usage.

```
ENTITY index_table
  SUBTYPE OF (nc_function);
  its_index:          INTEGER;
END_ENTITY;
```

### 4.2.171 Knurl

The Knurl application object is defined by clause 4.2 of ISO 14649-12:2005.

NOTE The ISO 14649 EXPRESS description for Knurl is shown below. Refer to ISO 14649-12 for the complete definition and explanation of usage.

```
ENTITY knurl
  ABSTRACT SUPERTYPE OF (ONEOF(straight_knurl, diagonal_knurl,
    diamond_knurl, tool_knurl))
  SUBTYPE OF (turning_feature);
  base_feature:          turning_feature;
  partial_profile:      OPTIONAL partial_area_definition;
  tooth_depth:          OPTIONAL toleranced_length_measure;
  diametral_pitch:      OPTIONAL toleranced_length_measure;
  root_fillet:          OPTIONAL toleranced_length_measure;
  number_of_teeth:      OPTIONAL INTEGER;
  major_diameter:       OPTIONAL toleranced_length_measure;
  nominal_diameter:     OPTIONAL toleranced_length_measure;
END_ENTITY;
```

### 4.2.172 Knurling

The Knurling application object is defined by clause 4.4 of ISO 14649-12:2005.

NOTE The ISO 14649 EXPRESS description for Knurling is shown below. Refer to ISO 14649-12 for the complete definition and explanation of usage.

```

ENTITY knurling
  SUBTYPE OF (turning_machining_operation);
END_ENTITY;

```

### 4.2.173 Knurling\_tool

The Knurling\_tool application object is defined by clause 4 of ISO 14649-121:2005.

NOTE The ISO 14649 EXPRESS description for Knurling\_tool is shown below. Refer to ISO 14649-121 for the complete definition and explanation of usage.

```

ENTITY knurling_tool
  SUBTYPE OF (turning_machine_cutting_tool);
  knurl_pattern: knurl_pattern_type;
  cutting_length: OPTIONAL length_measure;
  angle:         OPTIONAL plane_angle_measure;
  pitch:         OPTIONAL length_measure;
END_ENTITY;

TYPE knurl_pattern_type = ENUMERATION OF (straight, diagonal, diamond);
END_TYPE;

```

### 4.2.174 Last\_modified\_timestamp

A Last\_modified\_timestamp is an association between one or more projects, workpieces, executables, operations, or toolpaths and the point in time of their most recent modification or creation.

The data associated with a Last\_modified\_timestamp are the following:

- date\_and\_time\_value;
- items.

#### 4.2.174.1 date\_and\_time\_value

The date\_and\_time\_value specifies the point in time when the items were most recently modified or created.

#### 4.2.174.2 items

The items specifies the set of projects, workpieces, executables, operations, or toolpaths to which the date\_and\_time\_value applies. The items set shall contain at least one object. See 4.3.26, 4.3.27, 4.3.28, 4.3.29, and 4.3.30 for the application assertions.

### 4.2.175 Leading\_line\_strategy

The Leading\_line\_strategy application object is defined by clause 4 of ISO 14649-11:2004.

NOTE The ISO 14649 EXPRESS description for Leading\_line\_strategy is shown below. Refer to ISO 14649-11 for the complete definition and explanation of usage.

```
ENTITY leading_line_strategy
  SUBTYPE OF (freeform_strategy);
  its_line : bounded_curve;
END_ENTITY;
```

### 4.2.176 Length\_measure

A Length\_measure is a type of Value\_with\_unit (see 4.2.404) in which the value\_component describes a length.

NOTE As defined in ISO 14649-10, Length\_measure does not explicitly specify a unit. Instead, a default unit of millimeters is defined for all lengths. This part of ISO 10303 extends Length\_measure to explicitly specify units using the “unit” attribute inherited from Value\_with\_unit.

### 4.2.177 Length\_size\_dimension

A Length\_size\_dimension is a type of Size\_dimension (see 4.2.313) that defines the allowable variation in the length of an element of the product shape.

NOTE This definition has been harmonized with the Length\_size\_dimension definitions in ISO 10303-1050 and ISO 10303-214, as well as the Length\_dimension definition in ISO 10303-224.

The data associated with a Length\_size\_dimension are the following:

- used\_path.

#### 4.2.177.1 used\_path

The used\_path specifies a Measurement\_path along which the Length\_size\_dimension is measured. The used\_path need not be specified for a particular Length\_size\_dimension. See 4.3.31 for the application assertion.

### 4.2.178 Library\_part\_assignment

A Library\_part\_assignment is the means to reference information about a class within a parts library dictionary.

NOTE This definition has been harmonized with the Library\_part\_assignment definitions in ISO 10303-224 and ISO 10303-240.

The data associated with a Library\_part\_assignment are the following:

- definitional\_class\_bsu;
- definitional\_property\_value\_pairs.



### 4.2.178.1 **definitional\_class\_bsu**

The `definitional_class_bsu` specifies the `Class_BSU` object which identifies the component within a parts library as defined by ISO 13584. See 4.3.32 for the application assertion.

### 4.2.178.2 **definitional\_property\_value\_pairs**

The `definitional_property_value_pairs` specifies the set of `Library_property_value` objects which specify the property basic semantical units and values defining the properties of the class. The `definitional_property_value_pairs` need not be specified for a particular `Library_part_assignment`. See 4.3.33 for the application assertion.

## 4.2.179 **Library\_property\_value**

A `Library_property_value` is a value for a property as specified in the property basic semantical unit.

NOTE This definition has been harmonized with the `Property_value` definitions in ISO 10303-224 and ISO 10303-240.

The data associated with a `Library_property_value` are the following:

- `value_property_bsu`;
- `value_amount`.

### 4.2.179.1 **value\_property\_bsu**

The `value_property_bsu` specifies the `Property_BSU` object that defines the basic semantical unit. See 4.3.34 for the application assertion.

### 4.2.179.2 **value\_amount**

The `value_amount` specifies the value that is defined as a boolean, integer, number, logical, string, or real.

## 4.2.180 **Limit\_qualifier**

A `Limit_qualifier` specifies a limiting characteristic that is associated with a `Value_with_tolerance`.

NOTE When used with a `Value_with_tolerance`, this is equivalent to the `Value_limit` application object in ISO 10303-1106 [18] and ISO 10303-214, as well as the `Tolerance_limit` application object in ISO 10303-224.

### 4.2.180.1 **qualifier**

The `qualifier` identifies a limiting characteristic. One of the following values shall be used:

- maximum: the physical quantity may assume any value less than or equal to the value specified by the value\_component of the referencing Value\_with\_tolerance;
- minimum: the physical quantity may assume any value greater than or equal to the value specified by the value\_component of the referencing Value\_with\_tolerance;

## 4.2.181 Limits\_and\_fits

A Limits\_and\_fits is a tolerance specified by reference to the limits-and-fits system standardized by ISO 286. Limits and fits is a system for assigning tolerances associated with the assembly of mating product features.

NOTE This definition has been harmonized with the Limits\_and\_fits definitions in ISO 14649-10, ISO 10303-1050, ISO 10303-214, and ISO 10303-224. Limits and fits assigns a tolerance to a feature of size by classification rather than by giving an explicit value. A tolerance classification is composed of a fundamental deviation or "position letter" and a tolerance grade. These are used to calculate the size of the tolerance zone and its location relative to the basic or nominal size of the feature according to the tables and formulas found in ISO 286.

The data associated with a Limits\_and\_fits are the following:

- deviation;
- grade;
- its\_fitting\_type.

### 4.2.181.1 deviation

The deviation specifies the fundamental deviation or "position letter" of the ISO 286-1 limits-and-fits tolerance classification.

NOTE The characters 'A' to 'ZC' for holes or 'a' to 'zc' for shafts are used for deviation.

### 4.2.181.2 grade

The grade specifies the quality or the accuracy grade of a tolerance.

NOTE The grade is one of the 18 international standard tolerance grades defined in ISO 286-1, such as 'IT07'.

### 4.2.181.3 its\_fitting\_type

The its\_fitting\_type specifies the kind of fitting to which the tolerance applies. The its\_fitting\_type need not be specified for a particular Limits\_and\_fits. Normally the tolerance applies to an external or internal feature of the workpiece. Where applicable, the following values shall be used:

- hole: the tolerance applies to an internal feature of the workpiece;

— shaft: the tolerance applies to an external feature of the workpiece.

NOTE Whether the tolerance applies to an interior or exterior feature can be determined from the position letter of the fundamental deviation, therefore fitting\_type need not be specified.

### 4.2.182 Line\_profile\_tolerance

A Line\_profile\_tolerance is a type of Geometric\_tolerance (see 4.2.156) that specifies a uniform boundary along the true profile within which the elements of the surface shall lie. The tolerance zone established by a Line\_profile\_tolerance is two dimensional.

NOTE This definition has been harmonized with the Line\_profile\_tolerance definitions in ISO 10303-1051 and ISO 10303-214, and the Linear\_profile\_tolerance definition in ISO 10303-224. This definition is derived from clause 14.5 of ISO 1101:2004. Figure 14 illustrates a Line\_profile\_tolerance.

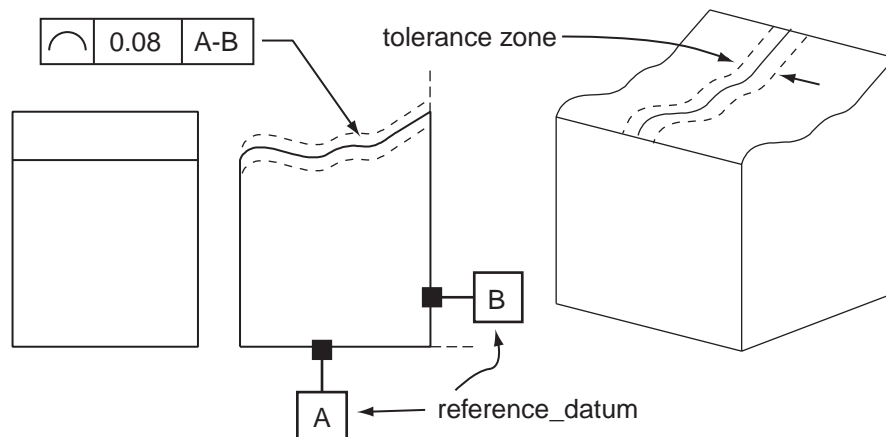


Figure 14 — Line\_profile\_tolerance

The data associated with a Line\_profile\_tolerance are the following:

- affected\_plane;
- reference\_datum.

#### 4.2.182.1 affected\_plane

The affected\_plane specifies an axis placement, the X-Y plane of which establishes the plane in which the tolerance applies. The affected\_plane need not be specified for a particular Line\_profile\_tolerance.

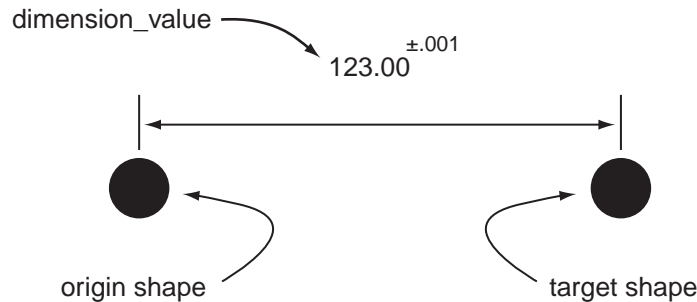
#### 4.2.182.2 reference\_datum

The reference\_datum specifies the set of Datum\_reference objects that define the reference frame for the geometric tolerance. See 4.3.35 for the application assertion.

### 4.2.183 Linear\_distance\_dimension

A Linear\_distance\_dimension is a type of Location\_dimension (see 4.2.187) that defines the allowable variation in the distance along a straight line between two elements of the shape of a part.

NOTE This definition has been harmonized with the Linear\_distance\_dimension definitions in ISO 10303-1050 and ISO 10303-214, as well as the Location\_dimension\_tolerance definition in ISO 10303-224. Figure 15 illustrates a Linear\_distance\_dimension.



**Figure 15 — Linear\_distance\_dimension**

The data associated with a Linear\_distance\_dimension are the following:

- orientation.

#### 4.2.183.1 orientation

The orientation specifies an axis placement giving a point and a direction along which the Linear\_distance\_dimension is measured. The direction is given by the X axis of the axis placement. The orientation need not be specified for a particular Linear\_distance\_dimension.

### 4.2.184 Linear\_path

The Linear\_path application object is defined by clause 4.5 of ISO 14649-10:2004.

NOTE The ISO 14649 EXPRESS description for Linear\_path is shown below. Refer to ISO 14649-10 for the complete definition and explanation of usage.

```
ENTITY linear_path
  SUBTYPE OF (travel_path);
  distance:          toleranced_length_measure;
  its_direction:    direction;
END_ENTITY;
```

### 4.2.185 Linear\_profile

The Linear\_profile application object is defined by clause 4.5 of ISO 14649-10:2004.

NOTE The ISO 14649 EXPRESS description for Linear\_profile is shown below. Refer to ISO 14649-10 for the complete definition and explanation of usage.

```
ENTITY linear_profile
  SUBTYPE OF (open_profile);
  profile_length:      numeric_parameter;
END_ENTITY;
```

## 4.2.186 Load\_tool

The Load\_tool application object is defined by clause 4 of ISO 14649-11:2004.

NOTE The ISO 14649 EXPRESS description for Load\_tool is shown below. Refer to ISO 14649-11 for the complete definition and explanation of usage.

```
ENTITY load_tool
  SUBTYPE OF (nc_function);
  its_tool:      machining_tool;
END_ENTITY;
```

## 4.2.187 Location\_dimension

A Location\_dimension is a type of Geometric\_dimension (see 4.2.155) that specifies the distance or angle that an origin shape element is displaced from a termination shape element.

NOTE This definition has been harmonized with the Location\_dimension definitions in ISO 10303-1050 and ISO 10303-214, as well as the Location\_tolerance definition in ISO 10303-224.

The data associated with a Location\_dimension are the following:

- description;
- directed;
- origin;
- target.

### 4.2.187.1 description

The description specifies text that provides further information about the Location\_dimension. The description need not be specified for a particular Location\_dimension.

### 4.2.187.2 directed

The directed specifies whether or not the direction is important for measuring a Location\_dimension. If the value is 'true' the Location\_dimension is measured from origin to target. A value of 'false' indicates that the direction for measuring the Location\_dimension is inconsequential. The directed need not be specified for a particular Location\_dimension.

### 4.2.187.3 origin

The origin specifies the shape element that defines the starting position for the Location\_dimension.

### 4.2.187.4 target

The target specifies the shape element that defines the ending position for the Location\_dimension.

### 4.2.188 Loop\_slot\_end\_type

The Loop\_slot\_end\_type application object is defined by clause 4.5 of ISO 14649-10:2004.

NOTE The ISO 14649 EXPRESS description for Loop\_slot\_end\_type is shown below. Refer to ISO 14649-10 for the complete definition and explanation of usage.

```
ENTITY loop_slot_end_type
  SUBTYPE OF (slot_end_type);
END_ENTITY;
```

### 4.2.189 Machine\_axis\_constraint

A Machine\_axis\_constraint identifies the range of motion that a machine axis may traverse.

NOTE It is advisable to avoid use of this information since it is machine dependent. To execute an operation or toolpath, an NC controller converts curves in space into specific axis motions. Some machine geometries do not have a unique solution. The machine\_axis\_constraint mechanism allows additional guidance to be provided to the controller by restricting the motion of one or more axes to be considered as part of the solution.

EXAMPLE When a rotary C table is mounted on a rotary B table, there may be two combinations of C and B angles that give the same tool axis direction. Also, when drilling on a machine with redundant (not necessarily parallel) linear axes, such as a machine with a movable quill (W axis), either the W or other axes could be used to advance the drill.

The data associated with a Machine\_axis\_constraint are the following:

- axis\_identifier;
- axis\_range.

#### 4.2.189.1 axis\_identifier

The axis\_identifier is a string value describing the name of the axis.

EXAMPLE The strings “x”, “y”, “z”, “a”, and “b” are common axis names.

## 4.2.189.2 axis\_range

The axis\_range specifies exactly one Value\_range containing upper and lower measure values permitted for that axis.

## 4.2.190 Machine\_axis\_travel

A Machine\_axis\_travel identifies the distance that a machine axis may traverse.

The data associated with a Machine\_axis\_travel are the following:

- axis\_identifier;
- travel\_distance.

### 4.2.190.1 axis\_identifier

The axis\_identifier is a string value describing the name of the axis.

EXAMPLE The strings “x”, “y”, “z”, “a”, and “b” are common axis names.

### 4.2.190.2 travel\_distance

The travel\_distance specifies a measure value that describes the distance that the identified axis can traverse.

NOTE A length measure value can be used to describe the traversal of linear axes, while a plane angle measure value can be used to describe the traversal of tilt tables and other angular axes.

## 4.2.191 Machine\_functions

The Machine\_functions application object is defined by clause 4.7 of ISO 14649-10:2004.

NOTE The ISO 14649 EXPRESS description for Machine\_functions is shown below. Refer to ISO 14649-10 for the complete definition and explanation of usage.

```
ENTITY machine_functions
  ABSTRACT SUPERTYPE;
END_ENTITY;
```

## 4.2.192 Machine\_parameters

A Machine\_parameters identifies the characteristics of a machine tool.

The data associated with a Machine\_parameters are the following:

- axis travel;

ISO 10303-238:2007(E)

- feedrate;
- number\_of\_control\_axis;
- number\_of\_simultaneous\_axis;
- positioning\_accuracy;
- spindle\_power;
- spindle\_torque;
- spindle\_speed;
- table\_indexing;
- table\_length;
- table\_width;
- work\_volume\_height;
- work\_volume\_length;
- work\_volume\_width.

#### **4.2.192.1 axis\_travel**

The `axis_travel` specifies zero or more `Machine_axis_travel` objects which describe the distance that the machine tool can move its cutting tool along specified axes. The `axis_travel` need not be specified for a particular `Machine_parameters` and the `axis_travel` shall not be specified if `work_volume_length`, `work_volume_width`, or `work_volume_height` is specified. See 4.3.36 for the application assertion.

#### **4.2.192.2 feedrate**

The `feedrate` specifies the linear velocity at which a machine tool can move its cutting tool. The `feedrate` need not be specified for a particular `Machine_parameters`.

#### **4.2.192.3 number\_of\_control\_axis**

The `number_of_control_axis` specifies number of machine tool axes that can be controlled by a numerical controller. The `number_of_control_axis` need not be specified for a particular `Machine_parameters`.



#### **4.2.192.4 number\_of\_simultaneous\_axis**

The `number_of_simultaneous_axis` specifies number of machine tool axes that can be controlled simultaneously by a numerical controller. The `number_of_simultaneous_axis` need not be specified for a particular `Machine_parameters`.

#### **4.2.192.5 positioning\_accuracy**

The `positioning_accuracy` specifies positioning accuracy of the machine tool axes considering displacement error and repeatability error. The `positioning_accuracy` need not be specified for a particular `Machine_parameters`.

#### **4.2.192.6 spindle\_power**

The `spindle_power` specifies the power which a machine tool can apply to turn its spindle. The `spindle_power` need not be specified for a particular `Machine_parameters`.

NOTE Spindle power is usually given in units of Kilowatts (for SI usage) or Horsepower (for English usage).

#### **4.2.192.7 spindle\_torque**

The `spindle_torque` specifies the torque which a machine tool can apply to turn its spindle. The `spindle_torque` need not be specified for a particular `Machine_parameters`.

NOTE Spindle torque is usually given in units of Newton Meters (for SI usage) or Foot Pounds (for English usage).

#### **4.2.192.8 spindle\_speed**

The `spindle_speed` specifies the rotational velocity at which a machine tool can move its spindle. The `spindle_speed` need not be specified for a particular `Machine_parameters`.

#### **4.2.192.9 table\_indexing**

The `table_indexing` specifies whether the machine tool table shall be capable of indexing. The `table_indexing` need not be specified for a particular `Machine_parameters`.

#### **4.2.192.10 table\_length**

The `table_length` specifies length of the machine tool work table. The `table_length` need not be specified for a particular `Machine_parameters`.

#### **4.2.192.11 table\_width**

The `table_width` specifies length of the machine tool work table. The `table_width` need not be specified for a particular `Machine_parameters`.

#### 4.2.192.12 work\_volume\_height

The work\_volume\_height specifies height of the volume in which the machine tool can move its cutting tool. The volume is aligned so that the height component lies along the Z axis of the machine. The work\_volume\_height need not be specified for a particular Machine\_parameters and the work\_volume\_height shall not be specified if axis\_travel is specified.

#### 4.2.192.13 work\_volume\_length

The work\_volume\_length specifies length of the volume in which the machine tool can move its cutting tool. The volume is aligned so that the length component lies along the X axis of the machine. The work\_volume\_length need not be specified for a particular Machine\_parameters and the work\_volume\_length shall not be specified if axis\_travel is specified.

#### 4.2.192.14 work\_volume\_width

The work\_volume\_width specifies width of the volume in which the machine tool can move its cutting tool. The volume is aligned so that the width component lies along the Y axis of the machine. The work\_volume\_width need not be specified for a particular Machine\_parameters and the work\_volume\_width shall not be specified if axis\_travel is specified.

### 4.2.193 Machined\_surface

The Machined\_surface application object is defined by clause 4.5 of ISO 14649-10:2004.

NOTE The ISO 14649 EXPRESS description for Machined\_surface is shown below. Refer to ISO 14649-10 for the complete definition and explanation of usage.

```
ENTITY machined_surface;
  its_machining_feature: machining_feature;
  surface_element:      bottom_or_side;
END_ENTITY;

TYPE bottom_or_side = ENUMERATION OF (bottom, side, bottom_and_side);
END_TYPE;
```

### 4.2.194 Machining\_feature

The Machining\_feature application object is defined by clause 4.5 of ISO 14649-10:2004. This part of ISO 10303 adds the following information requirements.

The data associated with a Machining\_feature are the following:

- all of the data defined by ISO 14649-10, as modified below for the depth attribute.

NOTE The ISO 14649 EXPRESS description for Machining\_feature, as adapted by this part of ISO 10303, is shown below. Refer to ISO 14649-10 for the original definition and explanation of usage.

```
ENTITY machining_feature
```

```

ABSTRACT SUPERTYPE OF (ONEOF(planar_face, pocket, slot, step, round_hole,
    toolpath_feature, profile_feature, boss, spherical_cap, rounded_end, thread))
SUBTYPE OF (two5D_manufacturing_feature);
depth: OPTIONAL elementary_surface; -- RELAXED BY 10303-238
END_ENTITY;

```

### 4.2.194.1 depth

The depth elementary surface is required by ISO 14649-10, but this part of ISO 10303 relaxes this requirement so that the depth need not be specified for a particular Machining\_feature.

NOTE As described in 5.2.1.2.1.1, the depth of a feature is defined by the the profile and path elements of the implicit feature definition. Within the AIM, the elementary surface called out as depth by ISO 14649-10 is represented by a parameter called “maximum feature depth,” which is an optional parameter in the ISO 10303-224 and ISO 10303-214 models.

### 4.2.195 Machining\_operation

The Machining\_operation application object is defined by clause 4.7 of ISO 14649-10:2004.

NOTE The ISO 14649 EXPRESS description for Machining\_operation is shown below. Refer to ISO 14649-10 for the complete definition and explanation of usage.

```

ENTITY machining_operation
  ABSTRACT SUPERTYPE
  SUBTYPE OF (operation);
  its_id: identifier;
  retract_plane: OPTIONAL length_measure;
  start_point: OPTIONAL cartesian_point;
  its_tool: machining_tool;
  its_technology: technology;
  its_machine_functions: machine_functions;
END_ENTITY;

```

### 4.2.196 Machining\_tool

The Machining\_tool application object is defined by clause 4.6 of ISO 14649-10:2004. This part of ISO 10303 adds the following information requirements.

The data associated with a Machining\_tool are the following:

- all of the data defined by ISO 14649-10;
- its\_usage.

NOTE The ISO 14649 EXPRESS description for Machining\_tool, as adapted by this part of ISO 10303, is shown below. Refer to ISO 14649-10 for the original definition and explanation of usage.

```

ENTITY machining_tool
  ABSTRACT SUPERTYPE;
  its_id: label;
  its_usage: OPTIONAL tool_usage; -- ADDED BY 10303-238
END_ENTITY;

```

### 4.2.196.1 its\_usage

The `its_usage` specifies a `Tool_usage` object that describes the tool selected to satisfy the tool requirements set forth by the `Machining_tool`. The `its_usage` need not be specified for a particular `Machining_tool`. See 4.3.36 for the application assertion.

### 4.2.197 Machining\_workingstep

The `Machining_workingstep` application object is defined by clause 4.6 of ISO 14649-10:2004. This part of ISO 10303 adds the following information requirements.

The data associated with a `Machining_workingstep` are the following:

- all of the data defined by ISO 14649-10;
- `final_features`;
- `toolpath_placement`.

NOTE The ISO 14649 EXPRESS description for `Machining_workingstep`, as adapted by this part of ISO 10303, is shown below. Refer to ISO 14649-10 for the original definition and explanation of usage.

```
ENTITY machining_workingstep
  SUBTYPE OF (workingstep);
  its_feature:      manufacturing_feature;
  its_operation:   machining_operation;
  its_effect:      OPTIONAL in_process_geometry;
  final_features:  OPTIONAL SET [0:?] OF Manufacturing_feature; -- ADDED BY 10303-238
  toolpath_orientation: OPTIONAL axis2_placement_3d;           -- ADDED BY 10303-238
END_ENTITY;
```

#### 4.2.197.1 final\_features

The `final_features` specifies a set of zero or more `Manufacturing_feature` objects visible on the final form of the workpiece that the `workingstep` contributes to. If the `machining_workingstep` `its_feature` is a process-specific feature consumed by further activities in a process, `final_features` may be used for traceability to features on the final form of the workpiece. The `final_features` need not be specified for a particular `Machining_workingstep`. See 4.3.38 for the application assertion. See 5.2.1.2.3 for additional discussion on the use of this attribute.

NOTE Consider the flow of data through the design and manufacture of a part. The features on the final part are usually the input to process planning, possibly described as an ISO 10303-224 data set. The output of macro process-planning, possibly described as an ISO 10303-240 data set, will include these features as well as intermediate features related to a particular process. This part of ISO 10303 describes the micro process-plan and is concerned with the features associated with a particular process, but having the ability to associate a process step with the ultimate feature on the final part allows us to preserve information flowing down from the larger process-plan. This will be of benefit to related downstream tasks, such as inspection, which could use the tracability to pinpoint critical areas of interest in the micro and macro process-plans.

EXAMPLE A workingstep drills a hole which is later used as the entry point for a pocketing operation. The hole is consumed by pocketing operation and not visible on the final form of the workpiece. The final\_features of the drilling workingstep may reference the pocket to indicate participation in the creation of that feature.

### 4.2.197.2 toolpath\_orientation

The toolpath\_orientation specifies the placement of the set of toolpaths given by the its\_operation its\_toolpath parameter. The toolpath\_orientation need not be specified for a particular Machining\_workingstep. If the toolpath\_orientation is not specified, the toolpaths shall assume an origin of (0,0,0) and axis directions X=(1,0,0) Y=(0,1,0) and Z=(0,0,1).

NOTE To reuse the toolpaths of an operation in a different location, ISO 14649 uses the origin from different features associated with the operation through a workingstep. This technique is not practical in this part of ISO 10303 because of feature harmonization constraints, since features often come from design and planning with origins that were convenient for the designer.

### 4.2.198 Manufacturing\_feature

This part of ISO 10303 adds the following information requirements to the Manufacturing\_feature application object defined by clause 4.4 of ISO 14649-10:2004

NOTE 1 The feature definitions from ISO 14649-10 only support an implicit definition of feature shape, using parameters such as width and height. For harmonization with ISO 10303-224 and other ISO 10303 parts, the following property has been added so that a Manufacturing\_feature can describe the feature shape explicitly, using geometry and topology elements, such as faces on the boundary representation of the workpiece.

The data associated with a Manufacturing\_feature are the following:

- all of the data defined by ISO 14649-10;
- explicit\_representation.

NOTE 2 The ISO 14649 EXPRESS description for Manufacturing\_feature, as adapted by this part of ISO 10303, is shown below. Refer to ISO 14649-10 for the original definition and explanation of usage.

```
ENTITY manufacturing_feature
  ABSTRACT SUPERTYPE OF (ONEOF(region, two5D_manufacturing_feature,
    transition_feature));
  its_id: identifier;
  its_workpiece: workpiece;
  its_operations: SET [0:?] OF machining_operation;
  explicit_representation: OPTIONAL SET [1:?] OF face; -- ADDED BY 10303-238
END_ENTITY;
```

### 4.2.198.1 explicit\_representation

The explicit\_representation specifies the shape of the feature using geometric face elements. This is a set of one or more faces on the boundary representation of the workpiece. The explicit\_representation

ISO 10303-238:2007(E)

need not be specified for a particular `Manufacturing_feature`. See 5.2.1.2.2 for additional discussion on the use of this attribute.

### 4.2.199 `Mass_measure`

An `Mass_measure` is a type of `Value_with_tolerance` (see 4.2.403) in which the `value_component` describes a mass quantity.

### 4.2.200 `Material`

The `Material` application object is defined by clause 4.4 of ISO 14649-10:2004.

NOTE The ISO 14649 EXPRESS description for `Material` is shown below. Refer to ISO 14649-10 for the complete definition and explanation of usage.

```
ENTITY material;  
  standard_identifier:    label;  
  material_identifier:   label;  
  material_property:    SET [0:?] OF property_parameter;  
END_ENTITY;
```

### 4.2.201 `Material_property`

A `Material_property` is a type of `General_property` (see 4.2.151) that describes the properties of the material used to produce a `Workpiece`.

NOTE This definition has been harmonized with the `Material_property` definitions in ISO 10303-224 and ISO 10303-240.

The data associated with a `Material_property` are the following:

- `material_characteristics`;
- `material_hardness`.

#### 4.2.201.1 `material_characteristics`

The `material_characteristics` specifies the set of `Property_parameter` objects that describe the `Material_property`. The `material_characteristics` need not be specified for a particular `Material_property`. See 4.3.40 for the application assertion.

#### 4.2.201.2 `material_hardness`

The `material_hardness` specifies the set of `Hardness` objects that describe hardness properties. The `material_hardness` need not be specified for a particular `Material_property`. See 4.3.39 for the application assertion.

## 4.2.202 Measurement\_path

A Measurement\_path is a path, direction, or domain of applicability for a dimension or tolerance. The path is represented by a Curve.

NOTE This definition has been harmonized with the Measurement\_path definition in ISO 10303-1031 [14].

The data associated with a Measurement\_path are the following:

- defined\_by;
- defined\_in.

### 4.2.202.1 defined\_by

The defined\_by attribute specifies the curve along which the measurement takes place.

### 4.2.202.2 defined\_in

The defined\_in attribute specifies the geometric context in which the measurement path is evaluated.

## 4.2.203 Milling\_cutting\_tool

The Milling\_cutting\_tool application object is defined by clause 4 of ISO 14649-111:—.

NOTE The ISO 14649 EXPRESS description for Milling\_cutting\_tool is shown below. Refer to ISO 14649-111 for the complete definition and explanation of usage.

```
ENTITY milling_cutting_tool
  ABSTRACT SUPERTYPE OF (ONEOF(dovetail_mill, endmill, facemill, shouldermill,
    side_mill, t_slot_mill, thread_mill))
  SUBTYPE OF (milling_machine_cutting_tool);
  number_of_effective_teeth: OPTIONAL INTEGER;
  edge_radius: OPTIONAL length_measure;
END_ENTITY;
```

## 4.2.204 Milling\_machine\_cutting\_tool

The Milling\_machine\_cutting\_tool application object is defined by clause 4 of ISO 14649-111:—.

NOTE The ISO 14649 EXPRESS description for Milling\_machine\_cutting\_tool is shown below. Refer to ISO 14649-111 for the complete definition and explanation of usage.

```
ENTITY milling_machine_cutting_tool
  ABSTRACT SUPERTYPE OF ( ONEOF(milling_cutting_tool, drilling_cutting_tool,
    tapping_cutting_tool, rotating_boring_cutting_tool, reaming_cutting_tool))
  SUBTYPE OF (machining_tool);
  its_cutting_edges: SET [1:?] OF cutting_component;
  overall_assembly_length: length_measure;
  effective_cutting_diameter: length_measure;
```

```

maximum_depth_of_cut:      length_measure;
hand_of_cut:                OPTIONAL hand_of_cut_type;
coolant_through_tool:      OPTIONAL BOOLEAN;
END_ENTITY;

TYPE hand_of_cut_type = ENUMERATION OF(left, neutral, right);
END_TYPE;

```

### 4.2.205 Milling\_machine\_functions

The Milling\_machine\_functions application object is defined by clause 4 of ISO 14649-11:2004. This part of ISO 10303 adds the following information requirements.

The data associated with a Milling\_machine\_functions are the following:

- all of the data defined by ISO 14649-11;
- axis\_constraints.

NOTE The ISO 14649 EXPRESS description for Milling\_machine\_functions, as adapted by this part of ISO 10303, is shown below. Refer to ISO 14649-11 for the original definition and explanation of usage.

```

ENTITY milling_machine_functions
  SUBTYPE OF (machine_functions);
  coolant:          BOOLEAN;
  coolant_pressure: OPTIONAL pressure_measure;
  mist:             OPTIONAL BOOLEAN;
  through_spindle_coolant: BOOLEAN;
  through_pressure: OPTIONAL pressure_measure;
  axis_clamping:    LIST [0:?] OF identifier;
  chip_removal:     BOOLEAN;
  oriented_spindle_stop: OPTIONAL direction;
  its_process_model: OPTIONAL process_model_list;
  other_functions:  SET [0:?] OF property_parameter;
  axis_constraints: OPTIONAL SET [0:?] OF machine_axis_constraint;-- ADDED BY 10303-238
END_ENTITY;

```

#### 4.2.205.1 axis\_constraints

The axis\_constraints specifies zero or more Machine\_axis\_constraint that shall be used by the NC control when computing axis motion. See 4.3.41 for the application assertion.

NOTE It is advisable to avoid use of this information since it is machine dependent.

### 4.2.206 Milling\_machining\_operation

The Milling\_machining\_operation application object is defined by clause 4 of ISO 14649-11:2004.

NOTE The ISO 14649 EXPRESS description for Milling\_machining\_operation is shown below. Refer to ISO 14649-11 for the complete definition and explanation of usage.

```

ENTITY milling_machining_operation
  ABSTRACT SUPERTYPE OF (ONEOF(milling_type_operation, drilling_type_operation))

```



```

SUBTYPE OF (machining_operation);
overcut_length: OPTIONAL length_measure;
WHERE
  WR1: (EXISTS(SELF.its_technology.feedrate_per_tooth) AND
        EXISTS(SELF.its_tool.number_of_effective_teeth)) OR
        (NOT(EXISTS(SELF.its_technology.feedrate_per_tooth)));
END_ENTITY;

```

#### 4.2.207 Milling\_technology

The Milling\_technology application object is defined by clause 4 of ISO 14649-11:2004.

NOTE The ISO 14649 EXPRESS description for Milling\_technology is shown below. Refer to ISO 14649-11 for the complete definition and explanation of usage.

```

ENTITY milling_technology
  SUBTYPE OF (technology);
  cutspeed:                OPTIONAL speed_measure;
  spindle:                 OPTIONAL rot_speed_measure;
  feedrate_per_tooth:     OPTIONAL length_measure;
  synchronize_spindle_with_feed: BOOLEAN;
  inhibit_feedrate_override: BOOLEAN;
  inhibit_spindle_override: BOOLEAN;
  its_adaptive_control:    OPTIONAL adaptive_control;
WHERE
  WR1: (EXISTS(cutspeed) AND NOT EXISTS(spindle))
        OR (EXISTS(spindle) AND NOT EXISTS(cutspeed))
        OR (EXISTS(its_adaptive_control));
  WR2: (EXISTS(SELF.feedrate) AND NOT EXISTS(feedrate_per_tooth))
        OR (EXISTS(feedrate_per_tooth) AND NOT EXISTS(SELF.feedrate))
        OR (EXISTS(its_adaptive_control));
END_ENTITY;

```

#### 4.2.208 Milling\_type\_operation

The Milling\_type\_operation application object is defined by clause 4 of ISO 14649-11:2004.

NOTE The ISO 14649 EXPRESS description for Milling\_type\_operation is shown below. Refer to ISO 14649-11 for the complete definition and explanation of usage.

```

ENTITY milling_type_operation
  ABSTRACT SUPERTYPE OF (ONEOF(freeform_operation, two5D_milling_operation))
  SUBTYPE OF (milling_machining_operation);
  approach:                OPTIONAL approach_retract_strategy;
  retract:                 OPTIONAL approach_retract_strategy;
END_ENTITY;

```

#### 4.2.209 Multiple\_arity\_boolean\_expression

The Multiple\_arity\_boolean\_expression application object is defined by clause 4.6 of ISO 14649-10:2004.

NOTE The ISO 14649 EXPRESS description for Multiple\_arity\_boolean\_expression is shown below. Refer to ISO 14649-10 for the complete definition and explanation of usage.

ISO 10303-238:2007(E)

```
ENTITY multiple_arity_boolean_expression
  ABSTRACT SUPERTYPE OF (ONEOF (and_expression, or_expression))
  SUBTYPE OF (boolean_expression);
  operands: LIST [2:?] OF boolean_expression;
END_ENTITY;
```

#### 4.2.210 Multistep\_drilling

The Multistep\_drilling application object is defined by clause 4 of ISO 14649-11:2004.

NOTE The ISO 14649 EXPRESS description for Multistep\_drilling is shown below. Refer to ISO 14649-11 for the complete definition and explanation of usage.

```
ENTITY multistep_drilling
  SUBTYPE OF (drilling_operation);
  retract_distance: length_measure;
  first_depth: length_measure;
  depth_of_step: length_measure;
  dwell_time_step: OPTIONAL time_measure;
END_ENTITY;
```

#### 4.2.211 Multistep\_grooving\_strategy

The Multistep\_grooving\_strategy application object is defined by clause 4.4 of ISO 14649-12:2005.

NOTE The ISO 14649 EXPRESS description for Multistep\_grooving\_strategy is shown below. Refer to ISO 14649-12 for the complete definition and explanation of usage.

```
ENTITY multistep_grooving_strategy
  SUBTYPE OF (grooving_strategy);
  retract_distance: length_measure;
END_ENTITY;
```

#### 4.2.212 NC\_constant

The NC\_constant application object is defined by clause 4.6 of ISO 14649-10:2004.

NOTE The ISO 14649 EXPRESS description for NC\_constant is shown below. Refer to ISO 14649-10 for the complete definition and explanation of usage.

```
ENTITY nc_constant;
  its_name: LABEL;
  its_value: OPTIONAL NUMBER;
END_ENTITY;
```

#### 4.2.213 NC\_function

The NC\_function application object is defined by clause 4.6 of ISO 14649-10:2004.

NOTE The ISO 14649 EXPRESS description for NC\_function is shown below. Refer to ISO 14649-10 for the complete definition and explanation of usage.

```

ENTITY nc_function
  ABSTRACT SUPERTYPE SUBTYPE OF (executable);
END_ENTITY;

```

#### 4.2.214 NC\_variable

The NC\_variable application object is defined by clause 4.6 of ISO 14649-10:2004.

NOTE The ISO 14649 EXPRESS description for NC\_variable is shown below. Refer to ISO 14649-10 for the complete definition and explanation of usage.

```

ENTITY nc_variable;
  its_name: LABEL;
  initial_value: OPTIONAL NUMBER;
END_ENTITY;

```

#### 4.2.215 Ngon\_profile

The Ngon\_profile application object is defined by clause 4.5 of ISO 14649-10:2004.

NOTE The ISO 14649 EXPRESS description for Ngon\_profile is shown below. Refer to ISO 14649-10 for the complete definition and explanation of usage.

```

ENTITY ngon_profile
  SUBTYPE OF (closed_profile);
  diameter: toleranced_length_measure;
  number_of_sides: INTEGER;
  circumscribed_or_across_flats: BOOLEAN;
END_ENTITY;

```

#### 4.2.216 Non\_sequential

The Non\_sequential application object is defined by clause 4.6 of ISO 14649-10:2004.

NOTE The ISO 14649 EXPRESS description for Non\_sequential is shown below. Refer to ISO 14649-10 for the complete definition and explanation of usage.

```

ENTITY non_sequential
  SUBTYPE OF (program_structure);
  its_elements: SET[2:?] OF executable;
END_ENTITY;

```

#### 4.2.217 Not\_expression

The Not\_expression application object is defined by clause 4.6 of ISO 14649-10:2004.

NOTE The ISO 14649 EXPRESS description for Not\_expression is shown below. Refer to ISO 14649-10 for the complete definition and explanation of usage.

```

ENTITY not_expression
  SUBTYPE OF (unary_boolean_expression);
END_ENTITY;

```

### 4.2.218 Numeric\_parameter

The Numeric\_parameter application object is defined by clause 4.4 of ISO 14649-10:2004.

NOTE The ISO 14649 EXPRESS description for Numeric\_parameter is shown below. Refer to ISO 14649-10 for the complete definition and explanation of usage.

```
ENTITY numeric_parameter
  SUBTYPE OF (Property_parameter);
  its_parameter_value: parameter_value;
  its_parameter_unit: label;
END_ENTITY;
```

### 4.2.219 Offset\_vector

The Offset\_vector application object is defined by clause 4.6 of ISO 14649-10:2004.

NOTE The ISO 14649 EXPRESS description for Offset\_vector is shown below. Refer to ISO 14649-10 for the complete definition and explanation of usage.

```
ENTITY offset_vector;
  translate: LIST [3:3] OF nc_variable;
  rotate: OPTIONAL LIST [3:3] OF nc_variable;
WHERE
  WR1: (SIZEOF(QUERY(i <* translate | NOT EXISTS(i.initial_value))) = 0)
  AND (NOT EXISTS(rotate) OR (SIZEOF(QUERY(i <* rotate |
  NOT EXISTS(i.initial_value))) = 0));
END_ENTITY;
```

### 4.2.220 Open\_pocket

The Open\_pocket application object is defined by clause 4.5 of ISO 14649-10:2004.

NOTE The ISO 14649 EXPRESS description for Open\_pocket is shown below. Refer to ISO 14649-10 for the complete definition and explanation of usage.

```
ENTITY open_pocket
  SUBTYPE OF (pocket);
  open_boundary: open_profile;
  wall_boundary: OPTIONAL open_profile;
END_ENTITY;
```

### 4.2.221 Open\_profile

The Open\_profile application object is defined by clause 4.5 of ISO 14649-10:2004.

NOTE The ISO 14649 EXPRESS description for Open\_profile is shown below. Refer to ISO 14649-10 for the complete definition and explanation of usage.

```
ENTITY open_profile
  ABSTRACT SUPERTYPE OF (ONEOF (linear_profile, square_u_profile, rounded_u_profile,
  tee_profile, vee_profile, partial_circular_profile, general_profile))
```

```

SUBTYPE OF (profile);
END_ENTITY;

```

#### 4.2.222 Open\_slot\_end\_type

The Open\_slot\_end\_type application object is defined by clause 4.5 of ISO 14649-10:2004.

NOTE The ISO 14649 EXPRESS description for Open\_slot\_end\_type is shown below. Refer to ISO 14649-10 for the complete definition and explanation of usage.

```

ENTITY open_slot_end_type
  SUBTYPE OF (slot_end_type);
END_ENTITY;

```

#### 4.2.223 Operation

The Operation application object is defined by clause 4.7 of ISO 14649-10:2004.

NOTE The ISO 14649 EXPRESS description for Operation is shown below. Refer to ISO 14649-10 for the complete definition and explanation of usage.

```

ENTITY operation
  ABSTRACT SUPERTYPE OF (ONEOF (machining_operation, rapid_movement, touch_probing));
  its_toolpath:          OPTIONAL toolpath_list;
  its_tool_direction:   OPTIONAL tool_direction;
END_ENTITY;

```

#### 4.2.224 Optional\_stop

The Optional\_stop application object is defined by clause 4.6 of ISO 14649-10:2004.

NOTE The ISO 14649 EXPRESS description for Optional\_stop is shown below. Refer to ISO 14649-10 for the complete definition and explanation of usage.

```

ENTITY optional_stop
  SUBTYPE OF (nc_function);
END_ENTITY;

```

#### 4.2.225 Or\_expression

The Or\_expression application object is defined by clause 4.6 of ISO 14649-10:2004.

NOTE The ISO 14649 EXPRESS description for Or\_expression is shown below. Refer to ISO 14649-10 for the complete definition and explanation of usage.

```

ENTITY or_expression
  SUBTYPE OF (multiple_arity_boolean_expression);
END_ENTITY;

```

### 4.2.226 Outer\_diameter

The Outer\_diameter application object is defined by clause 4.2 of ISO 14649-12:2005.

NOTE The ISO 14649 EXPRESS description for Outer\_diameter is shown below. Refer to ISO 14649-12 for the complete definition and explanation of usage.

```
ENTITY outer_diameter
  SUBTYPE OF (outer_round);
  diameter_at_placement: toleranced_length_measure;
  feature_length:        toleranced_length_measure;
  reduced_size:          OPTIONAL taper_select;
END_ENTITY;
```

### 4.2.227 Outer\_diameter\_to\_shoulder

The Outer\_diameter\_to\_shoulder application object is defined by clause 4.2 of ISO 14649-12:2005.

NOTE The ISO 14649 EXPRESS description for Outer\_diameter\_to\_shoulder is shown below. Refer to ISO 14649-12 for the complete definition and explanation of usage.

```
ENTITY outer_diameter_to_shoulder
  SUBTYPE OF (outer_round);
  diameter_at_placement: toleranced_length_measure;
  v_shape_boundary:     vee_profile;
END_ENTITY;
```

### 4.2.228 Outer\_round

The Outer\_round application object is defined by clause 4.2 of ISO 14649-12:2005.

NOTE The ISO 14649 EXPRESS description for Outer\_round is shown below. Refer to ISO 14649-12 for the complete definition and explanation of usage.

```
ENTITY outer_round
  ABSTRACT SUPERTYPE OF (ONEOF (outer_diameter, outer_diameter_to_shoulder))
  SUBTYPE OF (turning_feature);
END_ENTITY;
```

### 4.2.229 Parallel

The Parallel application object is defined by clause 4.6 of ISO 14649-10:2004.

NOTE The ISO 14649 EXPRESS description for Parallel is shown below. Refer to ISO 14649-10 for the complete definition and explanation of usage.

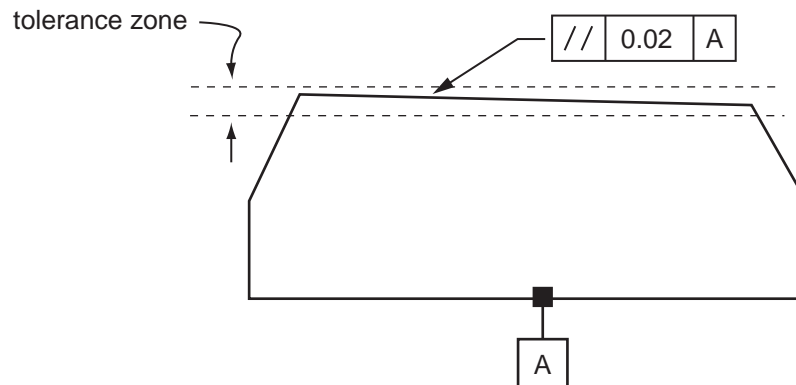
```
ENTITY parallel
  SUBTYPE OF (program_structure);
  branches:  SET [2:?] OF executable;
END_ENTITY;
```

### 4.2.230 Parallelism\_tolerance

A Parallelism\_tolerance is a type of Geometric\_tolerance (see 4.2.156) that specifies a surface or a curve shall be parallel to a reference datum, with an allowed amount of deviation. This reference datum is either a datum plane or a datum axis. A Parallelism\_tolerance specifies one of the following:

- a tolerance zone limited by two planes or two lines (if the attribute 'affected\_plane' is specified) parallel to a datum plane, or axis, within which the line elements of the surface or the axis of the considered feature shall lie;
- a cylindrical tolerance zone whose axis is parallel to a datum axis within which the axis of the considered feature shall lie.

NOTE This definition has been harmonized with the Parallelism\_tolerance definitions in ISO 10303-1051, ISO 10303-214, and ISO 10303-224. This definition is derived from clause 14.7 of ISO 1101:2004. Figure 16 illustrates a Parallelism\_tolerance.



**Figure 16 — Parallelism\_tolerance**

The data associated with a Parallelism\_tolerance are the following:

- affected\_plane;
- reference\_datum.

#### 4.2.230.1 affected\_plane

The affected\_plane specifies an axis placement, the X-Y plane of which establishes the plane in which the tolerance applies. The affected\_plane need not be specified for a particular Parallelism\_tolerance.

#### 4.2.230.2 reference\_datum

The reference\_datum specifies the set of Datum\_reference objects that define the reference frame for the geometric tolerance. See 4.3.42 for the application assertion.

### 4.2.231 Parameterised\_path

The Parameterised\_path application object is defined by clause 4.8 of ISO 14649-10:2004.

NOTE The ISO 14649 EXPRESS description for Parameterised\_path is shown below. Refer to ISO 14649-10 for the complete definition and explanation of usage.

```
ENTITY parameterised_path
  ABSTRACT SUPERTYPE OF (ONEOF (approach_lift_path, connector))
  SUBTYPE OF (toolpath);
END_ENTITY;
```

### 4.2.232 Part\_property

A Part\_property is a type of General\_property (see 4.2.151) that describes a specific characteristic about the form, fit, or function of a Workpiece.

NOTE This definition has been harmonized with the Part\_property definitions in ISO 10303-224 and ISO 10303-240.

The data associated with a Part\_property are the following:

— part\_characteristics.

#### 4.2.232.1 part\_characteristics

The part\_characteristics specifies the set of Property\_parameter objects that describe the Part\_property. The part\_characteristics need not be specified for a particular Part\_property. See 4.3.43 for the application assertion.

### 4.2.233 Partial\_area\_definition

The Partial\_area\_definition application object is defined by clause 4.5 of ISO 14649-10:2004.

NOTE The ISO 14649 EXPRESS description for Partial\_area\_definition is shown below. Refer to ISO 14649-10 for the complete definition and explanation of usage.

```
ENTITY partial_area_definition;
  effective_length: length_measure;
  placement: axis2_placement_3D;
  maximum_length: OPTIONAL length_measure;
END_ENTITY;
```

### 4.2.234 Partial\_circular\_path

The Partial\_circular\_path application object is defined by clause 4.5 of ISO 14649-10:2004.

NOTE The ISO 14649 EXPRESS description for Partial\_circular\_path is shown below. Refer to ISO 14649-10 for the complete definition and explanation of usage.



```

ENTITY partial_circular_path
  SUBTYPE OF (circular_path);
  sweep_angle: plane_angle_measure;
END_ENTITY;

```

#### 4.2.235 Partial\_circular\_profile

The Partial\_circular\_profile application object is defined by clause 4.5 of ISO 14649-10:2004.

NOTE The ISO 14649 EXPRESS description for Partial\_circular\_profile is shown below. Refer to ISO 14649-10 for the complete definition and explanation of usage.

```

ENTITY partial_circular_profile
  SUBTYPE OF (open_profile);
  radius: toleranced_length_measure;
  sweep_angle: plane_angle_measure;
END_ENTITY;

```

#### 4.2.236 Partial\_circular\_shape\_profile

The Partial\_circular\_shape\_profile application object is defined by clause 4.5 of ISO 14649-10:2004.

NOTE The ISO 14649 EXPRESS description for Partial\_circular\_shape\_profile is shown below. Refer to ISO 14649-10 for the complete definition and explanation of usage.

```

ENTITY partial_circular_shape_profile
  SUBTYPE OF (shape_profile);
  open_boundary : partial_circular_profile;
END_ENTITY;

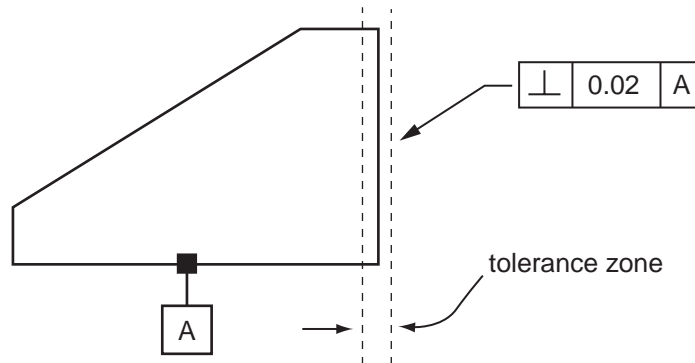
```

#### 4.2.237 Perpendicularity\_tolerance

A Perpendicularity\_tolerance is a type of Geometric\_tolerance (see 4.2.156) that specifies that a surface or a curve shall be perpendicular to a reference datum with an allowed amount of deviation. The reference datum is either a datum plane or a datum axis. A Perpendicularity\_tolerance specifies one of the following:

- a tolerance zone limited by two parallel planes perpendicular to a datum plane, or axis, within which the surface or median plane of the considered feature shall lie;
- a tolerance zone limited by two parallel planes perpendicular to a datum axis, within which the axis of the considered feature shall lie;
- a cylindrical tolerance zone (if the attribute ‘affected\_plane’ is not specified), perpendicular to a datum plane, within which the axis of the considered feature shall lie;
- a tolerance zone defined by two parallel lines perpendicular to a datum plane, or axis, within which an element of the surface shall lie.

NOTE This definition has been harmonized with the Perpendicularity\_tolerance definitions in ISO 10303-1051, ISO 10303-214, and ISO 10303-224. This definition is derived from clause 14.8 of ISO 1101:2004. Figure 17 illustrates a Perpendicularity\_tolerance.



**Figure 17 — Perpendicularity\_tolerance**

The data associated with a Perpendicularity\_tolerance are the following:

- affected\_plane;
- reference\_datum.

#### 4.2.237.1 affected\_plane

The affected\_plane specifies an axis placement, the X-Y plane of which establishes the plane in which the tolerance applies. The affected\_plane need not be specified for a particular Perpendicularity\_tolerance.

#### 4.2.237.2 reference\_datum

The reference\_datum specifies the set of Datum\_reference objects that define the reference frame for the geometric tolerance. See 4.3.44 for the application assertion.

#### 4.2.238 Person\_and\_address

The Person\_and\_address application object is defined by clause 4.3 of ISO 14649-10:2004.

NOTE The ISO 14649 EXPRESS description for Person\_and\_address is shown below. Refer to ISO 14649-10 for the complete definition and explanation of usage.

```
ENTITY person_and_address;
  its_person:    person;
  its_address:  OPTIONAL address;
END_ENTITY;
```

### 4.2.239 Placed\_target

A Placed\_target is a type of Datum\_target (see 4.2.105) that is described implicitly by parameters.

The data associated with a Placed\_target are the following:

- defined\_in;
- parameter\_reference;

#### 4.2.239.1 defined\_in

The defined\_in specifies the cartesian coordinate space in which the location and orientation that serves as parameter\_reference are defined.

NOTE A Placed\_target is not defined in its own local and independent coordinate space but in the coordinate space of the shape that provides the datum.

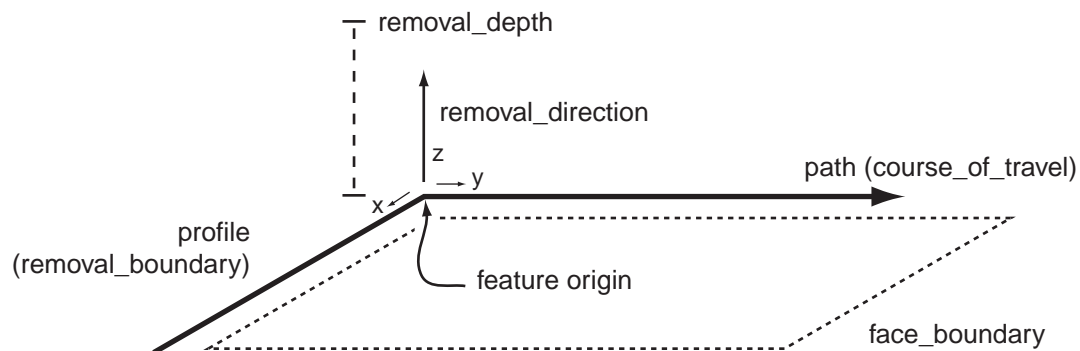
#### 4.2.239.2 parameter\_reference

The placement specifies location and orientation that the parameters or the Placed\_target refer to.

### 4.2.240 Planar\_face

The Planar\_face application object is defined by clause 4.5 of ISO 14649-10:2004. This part of ISO 10303 adds the following information requirements.

NOTE 1 The following properties have been added for harmonization with ISO 10303-224 and other ISO 10303 parts. Figure 18 illustrates the parameters associated with a Planar\_face. Refer to 5.2.1.3.1 for additional discussion on the location of the feature origin and other aspects of the Planar\_face application object.



**Figure 18 — Planar\_face parameters**

The data associated with a Planar\_face are the following:

- all of the data defined by ISO 14649-10;

ISO 10303-238:2007(E)

- removal\_depth;
- removal\_direction.

NOTE 2 The ISO 14649 EXPRESS description for Planar\_face, as adapted by this part of ISO 10303, is shown below. Refer to ISO 14649-10 for the original definition and explanation of usage.

```
ENTITY planar_face
  SUBTYPE OF (machining_feature);
  course_of_travel:    linear_path;
  removal_boundary:   linear_profile;
  face_boundary:     OPTIONAL closed_profile;
  its_boss:           SET [0:?] OF boss;
  removal_depth:     length_measure; -- ADDED BY 10303-238
  removal_direction: direction;      -- ADDED BY 10303-238
END_ENTITY;
```

#### 4.2.240.1 removal\_depth

The removal\_depth specifies the distance, measured along the removal direction, of material removal from the Planar\_face feature.

#### 4.2.240.2 removal\_direction

The removal\_direction specifies the direction of material removal from the Planar\_face feature.

#### 4.2.241 Planar\_pocket\_bottom\_condition

The Planar\_pocket\_bottom\_condition application object is defined by clause 4.5 of ISO 14649-10:2004.

NOTE The ISO 14649 EXPRESS description for Planar\_pocket\_bottom\_condition is shown below. Refer to ISO 14649-10 for the complete definition and explanation of usage.

```
ENTITY planar_pocket_bottom_condition
  SUBTYPE OF (pocket_bottom_condition);
END_ENTITY;
```

#### 4.2.242 Planar\_profile\_floor

The Planar\_profile\_floor application object is defined by clause 4.5 of ISO 14649-10:2004.

NOTE The ISO 14649 EXPRESS description for Planar\_profile\_floor is shown below. Refer to ISO 14649-10 for the complete definition and explanation of usage.

```
ENTITY planar_profile_floor
  SUBTYPE OF (profile_floor);
  floor:      plane;
END_ENTITY;
```

### 4.2.243 Plane\_angle\_measure

A Plane\_angle\_measure is a type of Value\_with\_tolerance (see 4.2.403) in which the value\_component describes a plane angle.

NOTE As defined in ISO 14649-10, Plane\_angle\_measure does not explicitly specify a unit. Instead, a default unit of degrees is defined for all plane angles. This part of ISO 10303 extends Plane\_angle\_measure to explicitly specify units using the “unit” attribute inherited from Value\_with\_unit. In addition, this measure can be qualified with a tolerance using the “limitation” attribute inherited from Value\_with\_tolerance.

### 4.2.244 Plane\_cc\_strategy

The Plane\_cc\_strategy application object is defined by clause 4 of ISO 14649-11:2004.

NOTE The ISO 14649 EXPRESS description for Plane\_cc\_strategy is shown below. Refer to ISO 14649-11 for the complete definition and explanation of usage.

```
ENTITY plane_cc_strategy
  SUBTYPE OF (freeform_strategy);
  its_plane_normal: direction;
END_ENTITY;
```

### 4.2.245 Plane\_cl\_strategy

The Plane\_cl\_strategy application object is defined by clause 4 of ISO 14649-11:2004.

NOTE The ISO 14649 EXPRESS description for Plane\_cl\_strategy is shown below. Refer to ISO 14649-11 for the complete definition and explanation of usage.

```
ENTITY plane_cl_strategy
  SUBTYPE OF (freeform_strategy);
  its_plane_normal: direction;
END_ENTITY;
```

### 4.2.246 Plane\_finish\_milling

The Plane\_finish\_milling application object is defined by clause 4 of ISO 14649-11:2004.

NOTE The ISO 14649 EXPRESS description for Plane\_finish\_milling is shown below. Refer to ISO 14649-11 for the complete definition and explanation of usage.

```
ENTITY plane_finish_milling
  SUBTYPE OF (plane_milling);
END_ENTITY;
```

### 4.2.247 Plane\_milling

The Plane\_milling application object is defined by clause 4 of ISO 14649-11:2004.

NOTE The ISO 14649 EXPRESS description for Plane\_milling is shown below. Refer to ISO 14649-11 for the complete definition and explanation of usage.

```
ENTITY plane_milling
  ABSTRACT SUPERTYPE OF (ONEOF(plane_rough_milling, plane_finish_milling))
  SUBTYPE OF (two5D_milling_operation);
  axial_cutting_depth: OPTIONAL length_measure;
  allowance_bottom:    OPTIONAL length_measure;
END_ENTITY;
```

#### 4.2.248 Plane\_rough\_milling

The Plane\_rough\_milling application object is defined by clause 4 of ISO 14649-11:2004.

NOTE The ISO 14649 EXPRESS description for Plane\_rough\_milling is shown below. Refer to ISO 14649-11 for the complete definition and explanation of usage.

```
ENTITY plane_rough_milling
  SUBTYPE OF (plane_milling);
WHERE
  WR1: EXISTS(SELF.allowance_bottom) AND (SELF.allowance_bottom>=0.0);
END_ENTITY;
```

#### 4.2.249 Plunge\_helix

The Plunge\_helix application object is defined by clause 4 of ISO 14649-11:2004.

NOTE The ISO 14649 EXPRESS description for Plunge\_helix is shown below. Refer to ISO 14649-11 for the complete definition and explanation of usage.

```
ENTITY plunge_helix
  SUBTYPE OF (plunge_strategy);
  radius:    length_measure;
  angle:     plane_angle_measure;
END_ENTITY;
```

#### 4.2.250 Plunge\_ramp

The Plunge\_ramp application object is defined by clause 4 of ISO 14649-11:2004.

NOTE The ISO 14649 EXPRESS description for Plunge\_ramp is shown below. Refer to ISO 14649-11 for the complete definition and explanation of usage.

```
ENTITY plunge_ramp
  SUBTYPE OF (plunge_strategy);
  angle:     plane_angle_measure;
END_ENTITY;
```

#### 4.2.251 Plunge\_strategy

The Plunge\_strategy application object is defined by clause 4 of ISO 14649-11:2004.

NOTE The ISO 14649 EXPRESS description for Plunge\_strategy is shown below. Refer to ISO 14649-11 for the complete definition and explanation of usage.

```
ENTITY plunge_strategy
  ABSTRACT SUPERTYPE OF (ONEOF (plunge_toolaxis, plunge_ramp,
    plunge_helix, plunge_zigzag))
  SUBTYPE OF (approach_retract_strategy);
END_ENTITY;
```

#### 4.2.252 Plunge\_toolaxis

The Plunge\_toolaxis application object is defined by clause 4 of ISO 14649-11:2004.

NOTE The ISO 14649 EXPRESS description for Plunge\_toolaxis is shown below. Refer to ISO 14649-11 for the complete definition and explanation of usage.

```
ENTITY plunge_toolaxis
  SUBTYPE OF (plunge_strategy);
END_ENTITY;
```

#### 4.2.253 Plunge\_zigzag

The Plunge\_zigzag application object is defined by clause 4 of ISO 14649-11:2004.

NOTE The ISO 14649 EXPRESS description for Plunge\_zigzag is shown below. Refer to ISO 14649-11 for the complete definition and explanation of usage.

```
ENTITY plunge_zigzag
  SUBTYPE OF (plunge_strategy);
  angle:      plane_angle_measure;
  width:      length_measure;
END_ENTITY;
```

#### 4.2.254 Plus\_minus\_value

A Plus\_minus\_value is the specification of a tolerance by offsets which are each added to the value\_component of a Value\_with\_tolerance, to create the two limits of the allowable range.

NOTE This definition has been harmonized with the Plus\_minus\_value definitions in ISO 10303-1050, ISO 10303-214, and ISO 10303-224. A definition for Plus\_minus\_value appears in ISO 14649-10, but only applies to length measures. This part of ISO 10303 extends the definition given by ISO 14649-10 to apply to any type of physical quantity given by a Value\_with\_tolerance. For harmonization, the significant\_digits data which appears in ISO 14649-10 is associated with the Value\_with\_tolerance application object.

The data associated with a Plus\_minus\_value are the following:

- lower\_limit;
- upper\_limit.

### 4.2.254.1 lower\_limit

The lower\_limit specifies the lower offset measure, which when added to the value\_component of a Value\_with\_tolerance gives the lowest allowable value for the physical quantity.

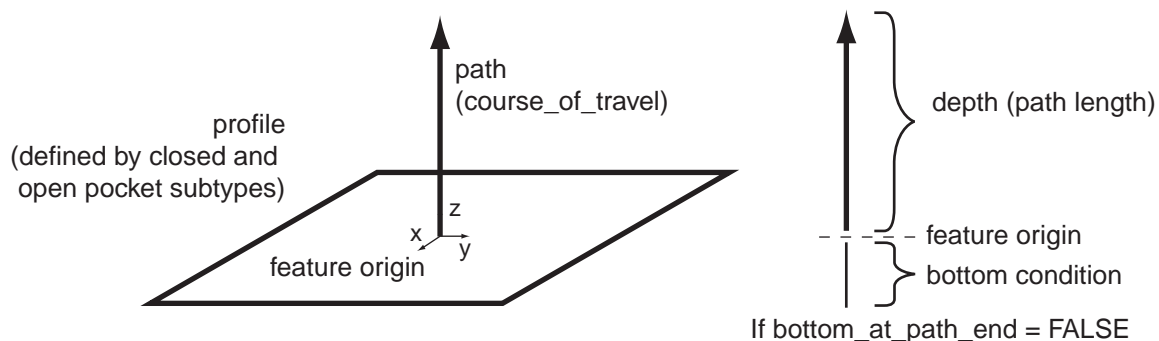
### 4.2.254.2 upper\_limit

The upper\_limit specifies the upper offset measure, which when added to the value\_component of a Value\_with\_tolerance gives the highest allowable value for the physical quantity.

## 4.2.255 Pocket

The Pocket application object is defined by clause 4.5 of ISO 14649-10:2004. This part of ISO 10303 adds the following information requirements.

NOTE 1 The following properties have been added for harmonization with ISO 10303-224 and other ISO 10303 parts. Figure 19 illustrates the parameters of a Pocket with the bottom condition located at the common origin of the feature, profile, and path (indicated by a value of FALSE for bottom\_at\_path\_end). Figure 20 illustrates a Pocket with the bottom condition located at the end of the course\_of\_travel path (indicated by a value of TRUE for bottom\_at\_path\_end). Refer to 5.2.1.3.3 for additional discussion on the location of the feature origin and other aspects of the Pocket application object.



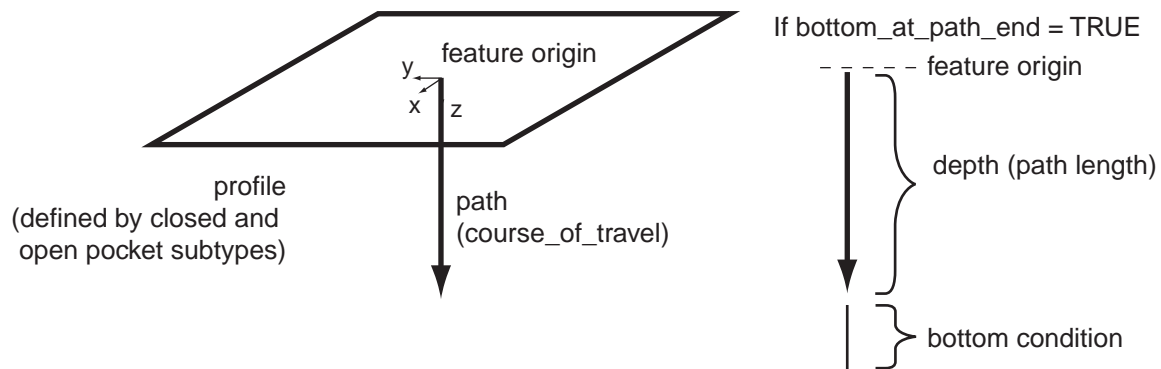
**Figure 19 — Pocket (bottom at path origin)**

The data associated with a Pocket are the following:

- all of the data defined by ISO 14649-10;
- bottom\_at\_path\_end;
- course\_of\_travel;
- top\_fillet\_radius.

NOTE 2 The ISO 14649 EXPRESS description for Pocket, as adapted by this part of ISO 10303, is shown below. Refer to ISO 14649-10 for the original definition and explanation of usage.





**Figure 20 — Pocket (bottom at path end)**

```

ENTITY pocket
  ABSTRACT SUPERTYPE OF (ONEOF(closed_pocket, open_pocket))
  SUBTYPE OF (machining_feature);
  its_boss:          SET [0:?] OF boss;
  slope:            OPTIONAL plane_angle_measure;
  bottom_condition: pocket_bottom_condition;
  planar_radius:   OPTIONAL toleranced_length_measure;
  orthogonal_radius: OPTIONAL toleranced_length_measure;
  bottom_at_path_end: BOOLEAN; -- ADDED BY 10303-238
  course_of_travel: linear_path; -- ADDED BY 10303-238
  top_fillet_radius: OPTIONAL toleranced_length_measure; -- ADDED BY 10303-238
END_ENTITY;

```

#### 4.2.255.1 bottom\_at\_path\_end

The `bottom_at_path_end` specifies the location of the `bottom_condition`. The `bottom_at_path_end` shall have a value of `TRUE` if the `bottom_condition` is positioned at the end of the `course_of_travel` path, and a value of `FALSE` if it is at the origin of `course_of_travel` path.

**NOTE** In ISO 10303-224, this parameter is known as `start_or_end` and is located on the `Pocket_bottom_condition` application object. In the integrated representation, this value is represented by the feature component relationship that ties a pocket bottom to a particular pocket. This parameter has been moved to `Pocket` to allow different values for different pockets which can share the same pocket bottom instance.

#### 4.2.255.2 course\_of\_travel

The `course_of_travel` specifies a `Linear_path` along which the profile defined by a pocket subtype (`feature_boundary` for `Closed_pocket`, `open_boundary` for `Open_pocket`) is swept to define the volume of the `Pocket`. The placement and orientation of the `course_of_travel` shall be the same as the `Pocket` feature. See 4.3.45 for the application assertion.

**NOTE** The length of the path is the depth of the pocket.

### 4.2.255.3 top\_fillet\_radius

The top\_fillet\_radius specifies the radius of a radius shape blend between the Pocket and the surrounding Workpiece surface at the top of the Pocket. The top\_fillet\_radius need not be specified for a particular Pocket.

NOTE In ISO 10303-224, this parameter is known as base\_radius, however, to avoid confusion with the orthogonal and planar radius parameters, the name top\_fillet\_radius is used.

### 4.2.256 Pocket\_bottom\_condition

The Pocket\_bottom\_condition application object is defined by clause 4.5 of ISO 14649-10:2004.

NOTE The ISO 14649 EXPRESS description for Pocket\_bottom\_condition is shown below. Refer to ISO 14649-10 for the complete definition and explanation of usage.

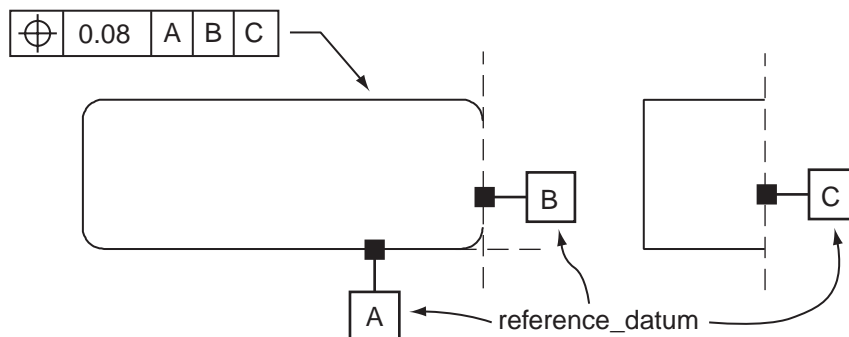
```

ENTITY pocket_bottom_condition
  ABSTRACT SUPERTYPE OF (ONEOF (through_pocket_bottom_condition,
    planar_pocket_bottom_condition, radiused_pocket_bottom_condition,
    general_pocket_bottom_condition));
END_ENTITY;
    
```

### 4.2.257 Position\_tolerance

A Position\_tolerance is a type of Geometric\_tolerance (see 4.2.156) that specifies the allowable variation in the position of a shape element. It can be interpreted either as defining a positional boundary within which the entire element is permitted to lie, or as defining a tolerance zone within which the centre, axis, or centre plane of the considered element is permitted to lie.

NOTE This definition has been harmonized with the Position\_tolerance definitions in ISO 10303-1051, ISO 10303-214, and ISO 10303-224. This definition is derived from clause 14.10 of ISO 1101:2004. The concept of position tolerances is defined in ISO 5458 [3]. Figure 21 illustrates a Position\_tolerance.



**Figure 21 — Position\_tolerance**

The data associated with a Position\_tolerance are the following:

- affected\_plane;
- reference\_datum.

#### 4.2.257.1 affected\_plane

The affected\_plane specifies an axis placement, the X-Y plane of which establishes the plane in which the tolerance applies. The affected\_plane need not be specified for a particular Position\_tolerance.

#### 4.2.257.2 reference\_datum

The reference\_datum specifies the set of Datum\_reference objects that define the reference frame for the geometric tolerance. See 4.3.46 for the application assertion.

NOTE When a Position\_tolerance is the feature relating Position\_tolerance of a composite tolerance, it need not have a datum reference frame.

#### 4.2.258 Pressure\_measure

A Pressure\_measure is a type of Value\_with\_tolerance (see 4.2.403) in which the value\_component describes a pressure.

NOTE As defined in ISO 14649-10, Pressure\_measure does not explicitly specify a unit. Instead, a default unit of Pascals is defined for all pressures. This part of ISO 10303 extends Pressure\_measure to allow units to be explicitly specified using the “unit” attribute inherited from Value\_with\_unit. In addition, this measure can be qualified with a tolerance using the “limitation” attribute inherited from Value\_with\_tolerance.

#### 4.2.259 Process\_model

The Process\_model application object is defined by clause 4 of ISO 14649-11:2004.

NOTE The ISO 14649 EXPRESS description for Process\_model is shown below. Refer to ISO 14649-11 for the complete definition and explanation of usage.

```
ENTITY process_model;
  ini_data_file: label;
  its_type: label;
END_ENTITY;
```

#### 4.2.260 Process\_model\_list

The Process\_model\_list application object is defined by clause 4 of ISO 14649-11:2004.

NOTE The ISO 14649 EXPRESS description for Process\_model\_list is shown below. Refer to ISO 14649-11 for the complete definition and explanation of usage.

```
ENTITY process_model_list;
  its_list: LIST [1:?] OF process_model;
END_ENTITY;
```

## 4.2.261 Process\_property

A Process\_property is a type of General\_property (see 4.2.151) that describes a specific characteristic about a process involved in the manufacture of a Workpiece.

NOTE This definition has been harmonized with the Process\_property definitions in ISO 10303-224 and ISO 10303-240.

The data associated with a Process\_property are the following:

- process\_characteristics;
- process\_name.

### 4.2.261.1 process\_characteristics

The process\_characteristics specifies the set of Property\_parameter objects that describe the Process\_property. The process\_characteristics need not be specified for a particular Process\_property. See 4.3.47 for the application assertion.

### 4.2.261.2 process\_name

The process\_name specifies a word or group of words by which a Process\_property is commonly referred.

## 4.2.262 Profile

The Profile application object is defined by clause 4.5 of ISO 14649-10:2004.

NOTE The ISO 14649 EXPRESS description for Profile is shown below. Refer to ISO 14649-10 for the complete definition and explanation of usage.

```
ENTITY profile
  ABSTRACT SUPERTYPE OF (ONEOF(closed_profile, open_profile));
  placement: OPTIONAL axis2_placement_3d;
END_ENTITY;
```

### 4.2.263 Profile\_feature

The Profile\_feature application object is defined by clause 4.5 of ISO 14649-10:2004.

NOTE The ISO 14649 EXPRESS description for Profile\_feature is shown below. Refer to ISO 14649-10 for the complete definition and explanation of usage.

```
ENTITY profile_feature
  ABSTRACT SUPERTYPE OF (ONEOF(general_outside_profile, shape_profile))
  SUBTYPE OF (machining_feature);
```

```

    profile_swept_shape : linear_path;
END_ENTITY;

```

#### 4.2.264 Profile\_floor

The Profile\_floor application object is defined by clause 4.5 of ISO 14649-10:2004.

NOTE The ISO 14649 EXPRESS description for Profile\_floor is shown below. Refer to ISO 14649-10 for the complete definition and explanation of usage.

```

ENTITY profile_floor
  ABSTRACT SUPERTYPE OF (ONEOF (general_profile_floor, planar_profile_floor));
  floor_radius:          OPTIONAL numeric_parameter;
  start_or_end:          BOOLEAN;
END_ENTITY;

```

#### 4.2.265 Profiled\_corner

The Profiled\_corner application object is defined by clause 4 of ISO 14649-121:2005.

NOTE The ISO 14649 EXPRESS description for Profiled\_corner is shown below. Refer to ISO 14649-121 for the complete definition and explanation of usage.

```

ENTITY profiled_corner;
  transition_profile:  open_profile;
END_ENTITY;

```

#### 4.2.266 Profiled\_end\_mill

The Profiled\_end\_mill application object is defined by clause 4 of ISO 14649-111:—.

NOTE The ISO 14649 EXPRESS description for Profiled\_end\_mill is shown below. Refer to ISO 14649-111 for the complete definition and explanation of usage.

```

ENTITY profiled_end_mill
  SUBTYPE OF (endmill);
END_ENTITY;

```

#### 4.2.267 Program\_stop

The Program\_stop application object is defined by clause 4.6 of ISO 14649-10:2004.

NOTE The ISO 14649 EXPRESS description for Program\_stop is shown below. Refer to ISO 14649-10 for the complete definition and explanation of usage.

```

ENTITY program_stop
  SUBTYPE OF (nc_function);
END_ENTITY;

```

## 4.2.268 Program\_structure

The Program\_structure application object is defined by clause 4.6 of ISO 14649-10:2004.

NOTE The ISO 14649 EXPRESS description for Program\_structure is shown below. Refer to ISO 14649-10 for the complete definition and explanation of usage.

```
ENTITY program_structure
  ABSTRACT SUPERTYPE OF (ONEOF(workplan, parallel, non_sequential, selective,
    if_statement, while_statement, assignment))
  SUBTYPE OF (executable);
END_ENTITY;
```

## 4.2.269 Project

The Project application object is defined by clause 4.3 of ISO 14649-10:2004.

NOTE The ISO 14649 EXPRESS description for Project is shown below. Refer to ISO 14649-10 for the complete definition and explanation of usage.

```
ENTITY project;
  its_id:          identifier;
  main_workplan:  workplan;
  its_workpieces: SET [0:?] OF workpiece;
  its_owner:      OPTIONAL person_and_address;
  its_release:    OPTIONAL date_and_time;
  its_status:     OPTIONAL approval;
END_ENTITY;
```

## 4.2.270 Projection

A Projection is a type of Tolerance\_zone\_definition (see 4.2.361) where a Tolerance\_zone is projected from an element of a part. The projection is external to the part and made from one of the ends of the element for a specified length.

NOTE The concept of projected tolerance zones is defined in ISO 10578.

The data associated with a Projection are the following:

- projection\_end;
- projection\_length.

### 4.2.270.1 projection\_end

The projection\_end specifies the shape element from which the tolerance zone is projected.

### 4.2.270.2 projection\_length

The projection\_length specifies the distance from the projection\_end where the Geometric\_tolerance shall be measured.

### 4.2.271 Property\_BSU

A Property\_BSU is a type of BSU (see 4.2.40) that identifies a property basic semantical unit of a class in a parts library.

NOTE This definition has been harmonized with the Property\_BSU definitions in ISO 10303-224 and ISO 10303-240.

The data associated with a Property\_BSU are the following:

- name\_scope;
- version.

#### 4.2.271.1 name\_scope

The name\_scope specifies Class\_BSU object which describes the class the property belongs to. See 4.3.48 for the application assertion.

#### 4.2.271.2 version

The version specifies the designation of the version of the information piece.

### 4.2.272 Property\_parameter

The Property\_parameter application object is defined by clause 4.4 of ISO 14649-10:2004.

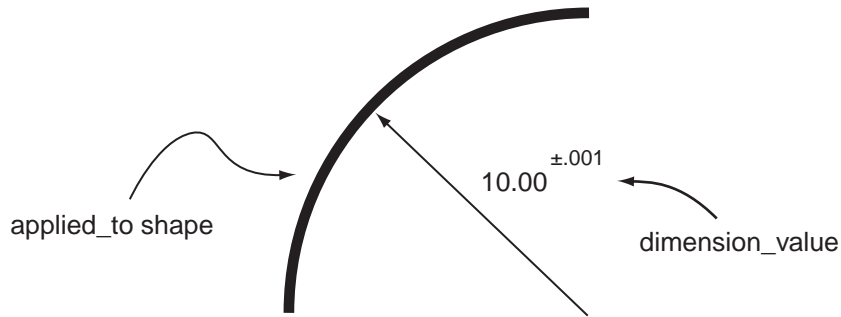
NOTE The ISO 14649 EXPRESS description for Property\_parameter is shown below. Refer to ISO 14649-10 for the complete definition and explanation of usage.

```
ENTITY property_parameter
  SUPERTYPE OF (ONEOF (descriptive_parameter, numeric_parameter));
  parameter_name:      label;
END_ENTITY;
```

### 4.2.273 Radial\_size\_dimension

An Radial\_size\_dimension is a type of Size\_dimension (see 4.2.313) that defines the allowable variation in the radius of a circular, cylindrical, or spherical shape element.

NOTE This definition has been harmonized with the Radial\_size\_dimension definitions in ISO 10303-1050 and ISO 10303-214, as well as the Radial\_dimension\_tolerance definition in ISO 10303-224. Figure 26 illustrates a Radial\_size\_dimension.



**Figure 22 — Radial\_size\_dimension**

The data associated with a Radial\_size\_dimension are the following:

- radius\_type.

#### 4.2.273.1 radius\_type

The radius\_type specifies the form of the tolerance zone. One of the following values shall be used. The radius\_type need not be specified for a particular Radial\_size\_dimension. If omitted, a value of ‘adjoining’ shall be assumed.

- centred: the tolerance zone is the shape in between two annular radial segments with their centres at the prescribed centre point. The radial tolerance permits steps in the tolerance zones with respect to its adjoining surface;

NOTE 1 A centred radial tolerance is typically applied to radial surfaces, such as filleted surfaces, that are located by centre point. It is drawn with a centre and the radial leader passes through the centre.

- adjoining: the tolerance zone is a crescent moon shape bounded by a minimum radius arc and a maximum radius arc, in which each arc shall be tangent to the adjacent surfaces.

NOTE 2 An adjoining radial tolerance typically applied to radial surfaces, such as filleted surfaces, that are located by adjoining surfaces. It is drawn without a centre and the radial leader just points to the radial surface.

#### 4.2.274 Radiused\_pocket\_bottom\_condition

The Radiused\_pocket\_bottom\_condition application object is defined by clause 4.5 of ISO 14649-10:2004.

NOTE The ISO 14649 EXPRESS description for Radiused\_pocket\_bottom\_condition is shown below. Refer to ISO 14649-10 for the complete definition and explanation of usage.

```

ENTITY radiused_pocket_bottom_condition
  SUBTYPE OF (pocket_bottom_condition);
  floor_radius_center: cartesian_point;
  floor_radius:        toleranced_length_measure;
END_ENTITY;
```



### 4.2.275 Radiused\_slot\_end\_type

The Radiused\_slot\_end\_type application object is defined by clause 4.5 of ISO 14649-10:2004.

NOTE The ISO 14649 EXPRESS description for Radiused\_slot\_end\_type is shown below. Refer to ISO 14649-10 for the complete definition and explanation of usage.

```
ENTITY radiused_slot_end_type
  SUBTYPE OF (slot_end_type);
END_ENTITY;
```

### 4.2.276 Rapid\_movement

The Rapid\_movement application object is defined by clause 4.6 of ISO 14649-10:2004.

NOTE The ISO 14649 EXPRESS description for Rapid\_movement is shown below. Refer to ISO 14649-10 for the complete definition and explanation of usage.

```
ENTITY rapid_movement
  SUPERTYPE OF (return_home)
  SUBTYPE OF (workingstep, operation);
END_ENTITY;
```

### 4.2.277 Reaming

The Reaming application object is defined by clause 4 of ISO 14649-11:2004.

NOTE The ISO 14649 EXPRESS description for Reaming is shown below. Refer to ISO 14649-11 for the complete definition and explanation of usage.

```
ENTITY reaming
  SUBTYPE OF (boring_operation);
END_ENTITY;
```

### 4.2.278 Reaming\_cutting\_tool

The Reaming\_cutting\_tool application object is defined by clause 4 of ISO 14649-111:—.

NOTE The ISO 14649 EXPRESS description for Reaming\_cutting\_tool is shown below. Refer to ISO 14649-111 for the complete definition and explanation of usage.

```
ENTITY reaming_cutting_tool
  SUPERTYPE OF (ONEOF (tapered_reamer, combined_drill_and_reamer))
  SUBTYPE OF (milling_machine_cutting_tool);
  taper_length: length_measure;
END_ENTITY;
```

### 4.2.279 Rectangular\_closed\_profile

The Rectangular\_closed\_profile application object is defined by clause 4.5 of ISO 14649-10:2004.

NOTE The ISO 14649 EXPRESS description for Rectangular\_closed\_profile is shown below. Refer to ISO 14649-10 for the complete definition and explanation of usage.

```
ENTITY rectangular_closed_profile
  SUBTYPE OF(closed_profile);
  profile_width:      toleranced_length_measure;
  profile_length:     toleranced_length_measure;
END_ENTITY;
```

### 4.2.280 Rectangular\_closed\_shape\_profile

The Rectangular\_closed\_shape\_profile application object is defined by clause 4.5 of ISO 14649-10:2004.

NOTE The ISO 14649 EXPRESS description for Rectangular\_closed\_shape\_profile is shown below. Refer to ISO 14649-10 for the complete definition and explanation of usage.

```
ENTITY rectangular_closed_shape_profile
  SUBTYPE OF (shape_profile);
  closed_boundary:    rectangular_closed_profile;
END_ENTITY;
```

### 4.2.281 Rectangular\_offset

The Rectangular\_offset application object is defined by clause 4.5 of ISO 14649-10:2004.

NOTE The ISO 14649 EXPRESS description for Rectangular\_offset is shown below. Refer to ISO 14649-10 for the complete definition and explanation of usage.

```
ENTITY rectangular_offset;
  offset_direction:  direction;
  offset_distance:   length_measure;
  row_index:         INTEGER;
  column_index:     INTEGER;
END_ENTITY;
```

### 4.2.282 Rectangular\_omit

The Rectangular\_omit application object is defined by clause 4.5 of ISO 14649-10:2004.

NOTE The ISO 14649 EXPRESS description for Rectangular\_omit is shown below. Refer to ISO 14649-10 for the complete definition and explanation of usage.

```
ENTITY rectangular_omit;
  row_index:         INTEGER;
  column_index:     INTEGER;
END_ENTITY;
```

### 4.2.283 Rectangular\_open\_shape\_profile

The Rectangular\_open\_shape\_profile application object is defined by clause 4.5 of ISO 14649-10:2004.

NOTE The ISO 14649 EXPRESS description for Rectangular\_open\_shape\_profile is shown below. Refer to ISO 14649-10 for the complete definition and explanation of usage.

```
ENTITY rectangular_open_shape_profile
  SUBTYPE OF (shape_profile);
  open_boundary:      square_u_profile;
END_ENTITY;
```

### 4.2.284 Rectangular\_pattern

The Rectangular\_pattern application object is defined by clause 4.5 of ISO 14649-10:2004.

NOTE The ISO 14649 EXPRESS description for Rectangular\_pattern is shown below. Refer to ISO 14649-10 for the complete definition and explanation of usage.

```
ENTITY rectangular_pattern
  SUBTYPE OF (replicate_feature);
  spacing:          toleranced_length_measure;
  its_direction:    direction;
  number_of_rows:   OPTIONAL INTEGER;
  number_of_columns: INTEGER;
  row_spacing:      OPTIONAL toleranced_length_measure;
  row_layout_direction: OPTIONAL direction;
  relocated_base_feature: SET[0:?] OF rectangular_offset;
  missing_base_feature: SET[0:?] OF rectangular_omit;
WHERE
  WR1: ((SELF.number_of_rows > 1 )
        AND EXISTS (SELF.row_spacing)
        AND EXISTS (SELF.row_layout_direction));
END_ENTITY;
```

### 4.2.285 Region

The Region application object is defined by clause 4.5 of ISO 14649-10:2004.

NOTE The ISO 14649 EXPRESS description for Region is shown below. Refer to ISO 14649-10 for the complete definition and explanation of usage.

```
ENTITY region
  ABSTRACT SUPERTYPE OF (ONEOF (region_surface_list, region_projection,
    topological_region))
  SUBTYPE OF (manufacturing_feature);
  feature_placement: OPTIONAL axis2_placement_3d;
END_ENTITY;
```

### 4.2.286 Region\_projection

The Region\_projection application object is defined by clause 4.5 of ISO 14649-10:2004.

ISO 10303-238:2007(E)

NOTE The ISO 14649 EXPRESS description for Region\_projection is shown below. Refer to ISO 14649-10 for the complete definition and explanation of usage.

```
ENTITY region_projection
  SUBTYPE OF (region);
  proj_curve:   bounded_curve;
  proj_dir:     direction;
  depth:        toleranced_length_measure;
END_ENTITY;
```

#### 4.2.287 Region\_surface\_list

The Region\_surface\_list application object is defined by clause 4.5 of ISO 14649-10:2004.

NOTE The ISO 14649 EXPRESS description for Region\_surface\_list is shown below. Refer to ISO 14649-10 for the complete definition and explanation of usage.

```
ENTITY region_surface_list
  SUBTYPE OF (region);
  surface_list: LIST [1:?] OF bounded_surface;
END_ENTITY;
```

#### 4.2.288 Replicate\_feature

The Replicate\_feature application object is defined by clause 4.5 of ISO 14649-10:2004.

NOTE The ISO 14649 EXPRESS description for Replicate\_feature is shown below. Refer to ISO 14649-10 for the complete definition and explanation of usage.

```
ENTITY replicate_feature
  ABSTRACT SUPERTYPE OF (ONEOF(rectangular_pattern, circular_pattern, general_pattern))
  SUBTYPE OF (two5D_manufacturing_feature);
  replicate_base_feature: two5D_manufacturing_feature;
END_ENTITY;
```

#### 4.2.289 Return\_home

The Return\_home application object is defined by clause 4.6 of ISO 14649-10:2004.

NOTE The ISO 14649 EXPRESS description for Return\_home is shown below. Refer to ISO 14649-10 for the complete definition and explanation of usage.

```
ENTITY return_home
  SUBTYPE OF (rapid_movement);
END_ENTITY;
```

#### 4.2.290 Revolved\_feature

The Revolved\_feature application object is defined by clause 4.2 of ISO 14649-12:2005.

NOTE The ISO 14649 EXPRESS description for Revolved\_feature is shown below. Refer to ISO 14649-12 for the complete definition and explanation of usage.

```
ENTITY revolved_feature
  ABSTRACT SUPERTYPE OF (ONEOF (revolved_round, revolved_flat, groove,
    general_revolution))
  SUBTYPE OF (turning_feature);
  material_side:      OPTIONAL direction;
  radius:             length_measure;
END_ENTITY;
```

#### 4.2.291 Revolved\_flat

The Revolved\_flat application object is defined by clause 4.2 of ISO 14649-12:2005.

NOTE The ISO 14649 EXPRESS description for Revolved\_flat is shown below. Refer to ISO 14649-12 for the complete definition and explanation of usage.

```
ENTITY revolved_flat
  SUBTYPE OF (revolved_feature);
  flat_edge_shape:   linear_profile;
END_ENTITY;
```

#### 4.2.292 Revolved\_round

The Revolved\_round application object is defined by clause 4.2 of ISO 14649-12:2005.

NOTE The ISO 14649 EXPRESS description for Revolved\_round is shown below. Refer to ISO 14649-12 for the complete definition and explanation of usage.

```
ENTITY revolved_round
  SUBTYPE OF (revolved_feature);
  rounded_edge_shape: partial_circular_profile;
END_ENTITY;
```

#### 4.2.293 Rot\_speed\_measure

A Rot\_speed\_measure is a type of Value\_with\_tolerance (see 4.2.403) in which the value\_component describes a rotational speed.

NOTE As defined in ISO 14649-10, Rot\_speed\_measure does not explicitly specify a unit. Instead, a default unit of revolutions per second is defined for all rotational speeds. This part of ISO 10303 extends Rot\_speed\_measure to allow units to be explicitly specified using the “unit” attribute inherited from Value\_with\_unit. In addition, this measure can be qualified with a tolerance using the “limitation” attribute inherited from Value\_with\_tolerance.

#### 4.2.294 Rotating\_boring\_cutting\_tool

The Rotating\_boring\_cutting\_tool application object is defined by clause 4 of ISO 14649-111:—.

NOTE The ISO 14649 EXPRESS description for Rotating\_boring\_cutting\_tool is shown below. Refer to ISO 14649-111 for the complete definition and explanation of usage.

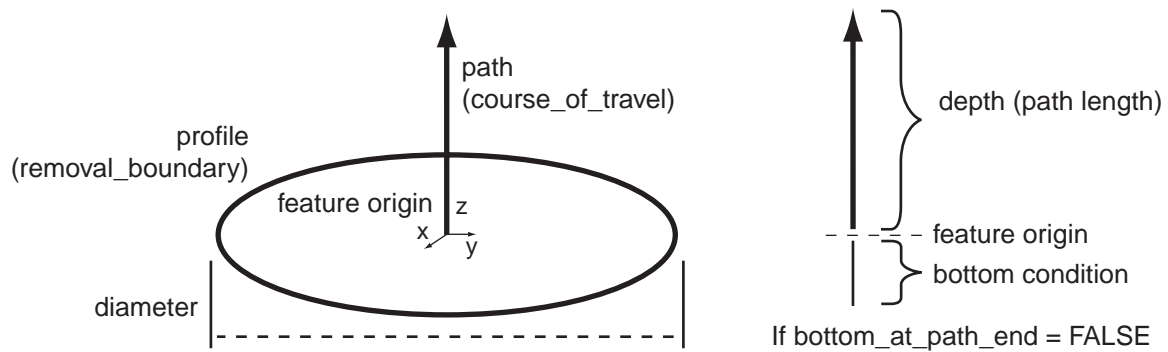
```

ENTITY rotating_boring_cutting_tool
  SUBTYPE OF (milling_machine_cutting_tool);
  retract_movement_forbidden: BOOLEAN;
END_ENTITY;

```

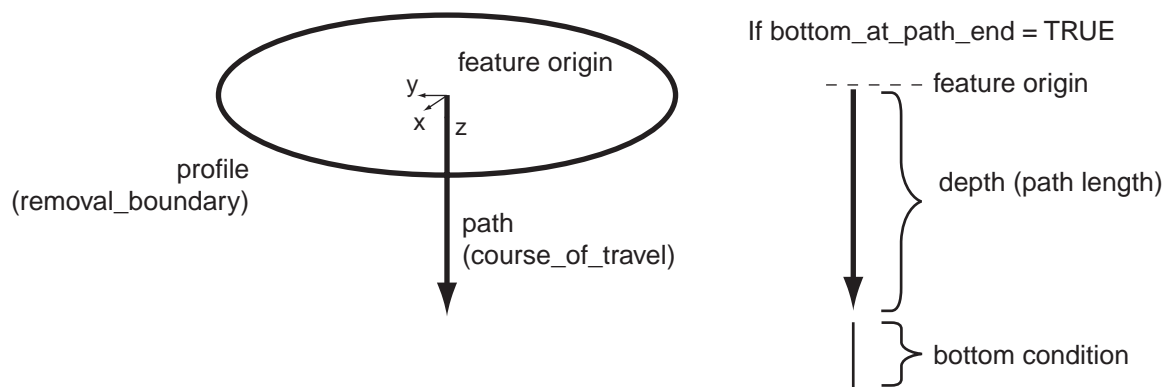
### 4.2.295 Round\_hole

The Round\_hole application object is defined by clause 4.5 of ISO 14649-10:2004. This part of ISO 10303 adds the following information requirements.



**Figure 23 — Round\_hole (bottom at path origin)**

NOTE 1 The following properties have been added for harmonization with ISO 10303-224 and other ISO 10303 parts. Figure 23 illustrates the parameters of a Round\_hole with the bottom condition located at the common origin of the feature, profile, and path (indicated by a value of FALSE for bottom\_at\_path\_end ). Figure 24 illustrates a Round\_hole with the bottom condition located at the end of the course\_of\_travel path (indicated by a value of TRUE for bottom\_at\_path\_end). Refer to 5.2.1.3.2 for additional discussion on the location of the feature origin and other aspects of the Round\_hole application object.



**Figure 24 — Round\_hole (bottom at path end)**

The data associated with a Round\_hole are the following:

- all of the data defined by ISO 14649-10;
- bottom\_at\_path\_end;
- course\_of\_travel.

NOTE 2 The ISO 14649 EXPRESS description for Round\_hole, as adapted by this part of ISO 10303, is shown below. Refer to ISO 14649-10 for the original definition and explanation of usage.

```

ENTITY round_hole
  SUBTYPE OF (machining_feature);
  diameter:          toleranced_length_measure;
  change_in_diameter:  OPTIONAL taper_select;
  bottom_condition:  hole_bottom_condition;
  bottom_at_path_end:  OPTIONAL BOOLEAN; -- ADDED BY 10303-238
  course_of_travel:   linear_path;      -- ADDED BY 10303-238

WHERE
  WR1: EXISTS (bottom_at_path_end) OR
        NOT ('BLIND_BOTTOM_CONDITION' IN TYPEOF(bottom_condition));
END_ENTITY;

TYPE taper_select = SELECT (diameter_taper, angle_taper);
END_TYPE;

```

#### 4.2.295.1 bottom\_at\_path\_end

The bottom\_at\_path\_end specifies the location of the bottom\_condition. The bottom\_at\_path\_end shall have a value of TRUE if the bottom\_condition is positioned at the end of the the course\_of\_travel path, and a value of FALSE if it is at the origin of course\_of\_travel path. This attribute shall only be specified if the hole bottom is of type Blind\_bottom\_condition.

NOTE In ISO 10303-224, this parameter is known as start\_or\_end and is located on the Blind\_bottom\_condition application object. However, in the integrated representation, this value is represented by the feature component relationship that ties a hole bottom to a particular hole. This parameter has been moved to Round\_hole to allow different values for different holes which can share the same hole bottom instance.

#### 4.2.295.2 course\_of\_travel

The course\_of\_travel specifies a Linear\_path along which the removal\_boundary profile is swept to define the volume of the Round\_hole. The placement and orientation of the course\_of\_travel shall be the same as the Round\_hole feature. See 4.3.49 for the application assertion.

NOTE The length of the path is the depth of the hole.

#### 4.2.296 Rounded\_corner

The Rounded\_corner application object is defined by clause 4 of ISO 14649-121:2005.

NOTE The ISO 14649 EXPRESS description for Rounded\_corner is shown below. Refer to ISO 14649-121 for the complete definition and explanation of usage.

```
ENTITY rounded_corner;  
  corner_radius:      length_measure;  
END_ENTITY;
```

### 4.2.297 Rounded\_end

The Rounded\_end application object is defined by clause 4.5 of ISO 14649-10:2004.

NOTE The ISO 14649 EXPRESS description for Rounded\_end is shown below. Refer to ISO 14649-10 for the complete definition and explanation of usage.

```
ENTITY rounded_end  
  SUBTYPE OF (machining_feature);  
  course_of_travel:      linear_path;  
  partial_circular_boundary: partial_circular_profile;  
END_ENTITY;
```

### 4.2.298 Rounded\_u\_profile

The Rounded\_u\_profile application object is defined by clause 4.5 of ISO 14649-10:2004. This part of ISO 10303 adds the following information requirements.

The data associated with a Rounded\_u\_profile are the following:

- all of the data defined by ISO 14649-10;
- depth.

NOTE The ISO 14649 EXPRESS description for Rounded\_u\_profile, as adapted by this part of ISO 10303, is shown below. Refer to ISO 14649-10 for the original definition and explanation of usage.

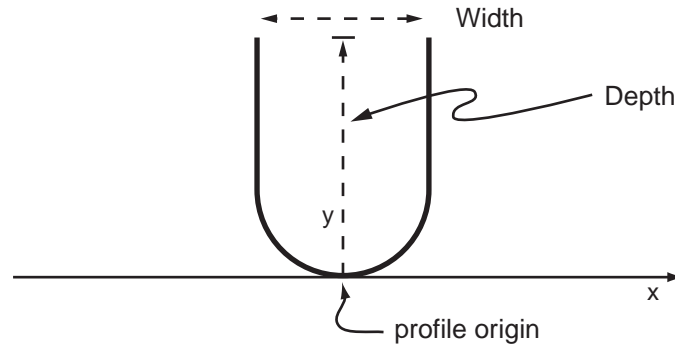
```
ENTITY rounded_u_profile  
  SUBTYPE OF (open_profile);  
  width:      toleranced_length_measure;  
  depth:      OPTIONAL toleranced_length_measure;      -- ADDED BY 10303-238  
END_ENTITY;
```

#### 4.2.298.1 depth

The depth specifies the distance from the midpoint of the arc, along the radius of the arc, to the top of the profile. The depth need not be specified for a particular Rounded\_u\_profile.

NOTE Figure 25 illustrates the parameters associated with a Rounded\_u\_profile.



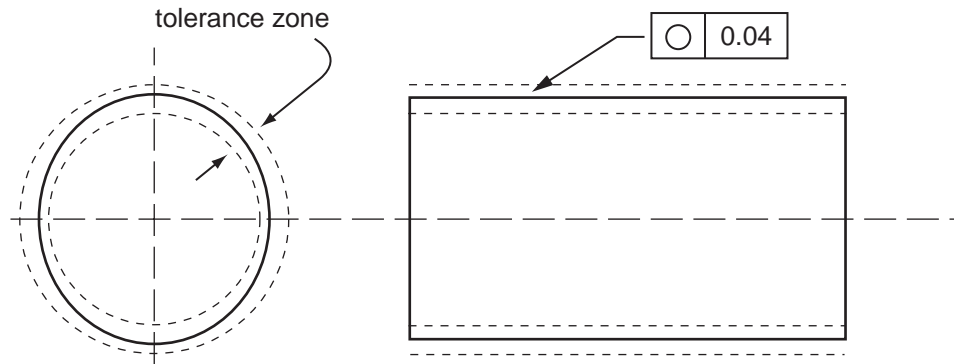


**Figure 25 — Rounded\_u\_profile parameters**

**4.2.299 Roundness\_tolerance**

A Roundness\_tolerance is a type of Geometric\_tolerance (see 4.2.156) that specifies a tolerance zone bounded by two concentric circles within which each circular element of a surface shall lie. For a sphere, a circular element is all points of the surface intersected by any plane passing through a common centre. For other surfaces, a circular element is all points of the surface intersected by any plane perpendicular to an axis. The Roundness\_tolerance condition applies independently at any plane.

NOTE This definition has been harmonized with the Roundness\_tolerance definitions in ISO 10303-1051, ISO 10303-214, and ISO 10303-224. Figure 26 illustrates a Roundness\_tolerance.



**Figure 26 — Roundness\_tolerance**

**4.2.300 Security\_classification**

A Security\_classification is a level of confidentiality that can be applied to protect activity or product data against unauthorized usage.

NOTE This definition has been harmonized with the Security\_classification definition in ISO 10303-1015.

The data associated with a Security\_classification are the following:

ISO 10303-238:2007(E)

- classification\_level;
- description.

#### **4.2.300.1 classification\_level**

The classification\_level is text that specifies the required degree of security.

EXAMPLE 'confidential' is an example of classification\_level that can be applied.

#### **4.2.300.2 description**

The description is text that provides further information about the Security\_classification. The description need not be specified for a particular Security\_classification.

#### **4.2.301 Security\_classification\_assignment**

A Security\_classification\_assignment is an association of a Security\_classification with activity or product data.

NOTE This definition has been harmonized with the Security\_classification\_assignment definition in ISO 10303-1015.

The data associated with a Security\_classification\_assignment are the following:

- classification;
- items.

##### **4.2.301.1 classification**

The classification specifies the Security\_classification assigned to activity or product data. See 4.3.53 for the application assertion.

##### **4.2.301.2 items**

The items specifies the set of projects, workpieces, executables, operations, or toolpaths to which the Security\_classification applies. The items set shall contain at least one object. See 4.3.50, 4.3.51, 4.3.52, 4.3.54, and 4.3.55 for the application assertions.

#### **4.2.302 Selective**

The Selective application object is defined by clause 4.6 of ISO 14649-10:2004.

NOTE The ISO 14649 EXPRESS description for Selective is shown below. Refer to ISO 14649-10 for the complete definition and explanation of usage.

```

ENTITY selective
  SUBTYPE OF (program_structure);
  its_elements: SET[2:?] OF executable;
END_ENTITY;

```

### 4.2.303 Set\_mark

The Set\_mark application object is defined by clause 4.6 of ISO 14649-10:2004.

NOTE The ISO 14649 EXPRESS description for Set\_mark is shown below. Refer to ISO 14649-10 for the complete definition and explanation of usage.

```

ENTITY set_mark
  SUBTYPE OF (nc_function);
END_ENTITY;

```

### 4.2.304 Setup

The Setup application object is defined by clause 4.6 of ISO 14649-10:2004.

NOTE The ISO 14649 EXPRESS description for Setup is shown below. Refer to ISO 14649-10 for the complete definition and explanation of usage.

```

ENTITY setup;
  its_id: identifier;
  its_origin: OPTIONAL axis2_placement_3d;
  its_secplane: elementary_surface;
  its_workpiece_setup: LIST [0:?] OF workpiece_setup;
END_ENTITY;

```

### 4.2.305 Setup\_instruction

The Setup\_instruction application object is defined by clause 4.6 of ISO 14649-10:2004.

NOTE The ISO 14649 EXPRESS description for Setup\_instruction is shown below. Refer to ISO 14649-10 for the complete definition and explanation of usage.

```

ENTITY setup_instruction;
  description: OPTIONAL text;
  external_document: OPTIONAL identifier;
WHERE
  WR1: EXISTS (description) OR EXISTS (external_document);
END_ENTITY;

```

### 4.2.306 Shape\_profile

The Shape\_profile application object is defined by clause 4.5 of ISO 14649-10:2004.

NOTE The ISO 14649 EXPRESS description for Shape\_profile is shown below. Refer to ISO 14649-10 for the complete definition and explanation of usage.

```

ENTITY shape_profile

```

```

ABSTRACT SUPERTYPE OF (ONEOF (general_shape_profile, partial_circular_shape_profile,
    circular_closed_shape_profile, rectangular_open_shape_profile,
    rectangular_closed_shape_profile))
SUBTYPE OF (profile_feature);
floor_condition:      profile_select;
removal_direction:   direction;
END_ENTITY;

TYPE profile_select = SELECT (through_profile_floor, profile_floor);
END_TYPE;

```

### 4.2.307 Shouldermill

The Shouldermill application object is defined by clause 4 of ISO 14649-111:—.

NOTE The ISO 14649 EXPRESS description for Shouldermill is shown below. Refer to ISO 14649-111 for the complete definition and explanation of usage.

```

ENTITY shouldermill
    SUBTYPE OF (milling_cutting_tool);
END_ENTITY;

```

### 4.2.308 Side\_finish\_milling

The Side\_finish\_milling application object is defined by clause 4 of ISO 14649-11:2004.

NOTE The ISO 14649 EXPRESS description for Side\_finish\_milling is shown below. Refer to ISO 14649-11 for the complete definition and explanation of usage.

```

ENTITY side_finish_milling
    SUBTYPE OF (side_milling);
END_ENTITY;

```

### 4.2.309 Side\_mill

The Side\_mill application object is defined by clause 4 of ISO 14649-111:—.

NOTE The ISO 14649 EXPRESS description for Side\_mill is shown below. Refer to ISO 14649-111 for the complete definition and explanation of usage.

```

ENTITY side_mill
    SUBTYPE OF (milling_cutting_tool);
    cutter_width: length_measure;
END_ENTITY;

```

### 4.2.310 Side\_milling

The Side\_milling application object is defined by clause 4 of ISO 14649-11:2004.

NOTE The ISO 14649 EXPRESS description for Side\_milling is shown below. Refer to ISO 14649-11 for the complete definition and explanation of usage.

```

ENTITY side_milling
  ABSTRACT SUPERTYPE OF (ONEOF(side_rough_milling, side_finish_milling))
  SUBTYPE OF (two5D_milling_operation);
  axial_cutting_depth:    OPTIONAL length_measure;
  radial_cutting_depth:  OPTIONAL length_measure;
  allowance_side:        OPTIONAL length_measure;
END_ENTITY;

```

### 4.2.311 Side\_rough\_milling

The Side\_rough\_milling application object is defined by clause 4 of ISO 14649-11:2004.

NOTE The ISO 14649 EXPRESS description for Side\_rough\_milling is shown below. Refer to ISO 14649-11 for the complete definition and explanation of usage.

```

ENTITY side_rough_milling
  SUBTYPE OF (side_milling);
  WHERE
    WR1: EXISTS(SELF.allowance_side) AND (SELF.allowance_side>=0.0);
END_ENTITY;

```

### 4.2.312 Single\_datum

A Single\_datum is a type of Datum (see 4.2.100) that specifies a point, line, axis, or plane used as a reference for locating and orienting tolerance zones.

The data associated with a Single\_datum are the following:

- datum\_name;
- modification.

#### 4.2.312.1 datum\_name

The datum\_name specifies the word or group of words by which the Single\_datum is referred to.

EXAMPLE Typical names of Single\_datum objects are 'A', 'B', or 'C'.

#### 4.2.312.2 modification

The modification specifies a Tolerance\_condition that is associated with the application of the Single\_datum. The modification need not be specified for a particular Single\_datum. See 4.3.56 for the application assertion.

EXAMPLE Material conditions such as LMC or MMC are typical conditions.

### 4.2.313 Size\_dimension

A Size\_dimension is a type of Geometric\_dimension (see 4.2.155) that specifies the size of an individual element of the shape of a part.

NOTE 1 This definition has been harmonized with the Size\_dimension definitions in ISO 10303-1050 and ISO 10303-214, as well as the Size\_tolerance definition in ISO 10303-224.

NOTE 2 Size\_dimension as defined in this part of ISO 10303 describe an intrinsic length or angle characteristic of part shape. This includes characteristics of what are traditionally called “features-of-size,” but they are not limited to that usage alone. For example, the radial\_size\_dimension and curved\_size\_dimension application objects describe characteristics which can not be applied to features-of-size.

The data associated with a Size\_dimension are the following:

- applied\_to;
- envelope\_principle.

### 4.2.313.1 applied\_to

The applied\_to specifies the shape element to which the Size\_dimension applies.

### 4.2.313.2 envelope\_principle

The envelope\_principle specifies whether or not the envelope principle applies to this size dimension. A value of 'true' indicates that the envelope principle applies. The envelope\_principle need not be specified for a particular Size\_dimension.

When the envelope principle applies, the envelope of the perfect shape corresponding to the maximum material shall not be larger than the specified dimension and tolerance. The envelope principle specifies that size and form tolerances are not additive.

NOTE The Envelope principle is defined in ISO 1101. It is equivalent to ASME Y14.5 rule 1.

## 4.2.314 Slot

The Slot application object is defined by clause 4.5 of ISO 14649-10:2004.

NOTE The ISO 14649 EXPRESS description for Slot is shown below. Refer to ISO 14649-10 for the complete definition and explanation of usage.

```
ENTITY slot
  SUBTYPE OF (machining_feature);
  course_of_travel:    travel_path;
  swept_shape:        open_profile;
  end_conditions:     LIST[0:2] OF slot_end_type;
WHERE
  WR1: (( SIZEOF(QUERY (it <* SELF.end_conditions |
    ('LOOP_SLOT_END_TYPE' IN TYPEOF(it)) )) = 1) AND
    (SIZEOF(end_conditions) = 1) ) OR
    (SIZEOF(end_conditions) <> 1);
END_ENTITY;
```

### 4.2.315 Slot\_end\_type

The Slot\_end\_type application object is defined by clause 4.5 of ISO 14649-10:2004.

NOTE The ISO 14649 EXPRESS description for Slot\_end\_type is shown below. Refer to ISO 14649-10 for the complete definition and explanation of usage.

```
ENTITY slot_end_type
  ABSTRACT SUPERTYPE OF (ONEOF (woodruff_slot_end_type, radiused_slot_end_type,
    flat_slot_end_type, loop_slot_end_type, open_slot_end_type));
END_ENTITY;
```

### 4.2.316 Spade\_drill

The Spade\_drill application object is defined by clause 4 of ISO 14649-111:—.

NOTE The ISO 14649 EXPRESS description for Spade\_drill is shown below. Refer to ISO 14649-111 for the complete definition and explanation of usage.

```
ENTITY spade_drill
  SUBTYPE OF (drilling_cutting_tool);
END_ENTITY;
```

### 4.2.317 Specification

The Specification application object is defined by clause 4.5 of ISO 14649-10:2004.

NOTE The ISO 14649 EXPRESS description for Specification is shown below. Refer to ISO 14649-10 for the complete definition and explanation of usage.

```
ENTITY specification;
  constraint:          SET [0:?] OF specification_usage_constraint;
  specification_id:   text;
  specification_description: OPTIONAL text;
  specification_class:  OPTIONAL text;
END_ENTITY;
```

### 4.2.318 Specification\_usage\_constraint

The Specification\_usage\_constraint application object is defined by clause 4.5 of ISO 14649-10:2004.

NOTE The ISO 14649 EXPRESS description for Specification\_usage\_constraint is shown below. Refer to ISO 14649-10 for the complete definition and explanation of usage.

```
ENTITY specification_usage_constraint;
  element:          text;
  class_id:         text;
END_ENTITY;
```

### 4.2.319 Speed\_measure

A Speed\_measure is a type of Value\_with\_tolerance (see 4.2.403) in which the value\_component describes a linear speed.

NOTE As defined in ISO 14649-10, Speed\_measure does not explicitly specify a unit. Instead, a default unit of meters per second is defined for all linear speeds. This part of ISO 10303 extends Speed\_measure to allow units to be explicitly specified using the “unit” attribute inherited from Value\_with\_unit. In addition, this measure can be qualified with a tolerance using the “limitation” attribute inherited from Value\_with\_tolerance.

### 4.2.320 Spherical\_cap

The Spherical\_cap application object is defined by clause 4.5 of ISO 14649-10:2004.

NOTE The ISO 14649 EXPRESS description for Spherical\_cap is shown below. Refer to ISO 14649-10 for the complete definition and explanation of usage.

```
ENTITY spherical_cap
  SUBTYPE OF (machining_feature);
  internal_angle:      numeric_parameter;
  radius:              numeric_parameter;
END_ENTITY;
```

### 4.2.321 Spherical\_hole\_bottom

The Spherical\_hole\_bottom application object is defined by clause 4.5 of ISO 14649-10:2004.

NOTE The ISO 14649 EXPRESS description for Spherical\_hole\_bottom is shown below. Refer to ISO 14649-10 for the complete definition and explanation of usage.

```
ENTITY spherical_hole_bottom
  SUBTYPE OF (blind_bottom_condition);
  radius: toleranced_length_measure;
END_ENTITY;
```

### 4.2.322 Spotdrill

The Spotdrill application object is defined by clause 4 of ISO 14649-111:—.

NOTE The ISO 14649 EXPRESS description for Spotdrill is shown below. Refer to ISO 14649-111 for the complete definition and explanation of usage.

```
ENTITY spotdrill
  SUBTYPE OF (drilling_cutting_tool);
END_ENTITY;
```



### 4.2.323 Square\_u\_profile

The Square\_u\_profile application object is defined by clause 4.5 of ISO 14649-10:2004. This part of ISO 10303 adds the following information requirements.

The data associated with a Square\_u\_profile are the following:

- all of the data defined by ISO 14649-10;
- depth.

NOTE The ISO 14649 EXPRESS description for Square\_u\_profile, as adapted by this part of ISO 10303, is shown below. Refer to ISO 14649-10 for the original definition and explanation of usage.

```

ENTITY square_u_profile
  SUBTYPE OF (open_profile);
  width:          toleranced_length_measure;
  first_radius:   toleranced_length_measure;
  first_angle:    plane_angle_measure;
  second_radius:  toleranced_length_measure;
  second_angle:   plane_angle_measure;
  depth:          OPTIONAL toleranced_length_measure;  -- ADDED BY 10303-238
END_ENTITY;

```

#### 4.2.323.1 depth

The depth specifies the distance from the centre of the base line, measured perpendicular to the base line, to the top of the profile. The depth need not be specified for a particular Square\_u\_profile.

NOTE Figure 27 illustrates the parameters associated with a Square\_u\_profile.

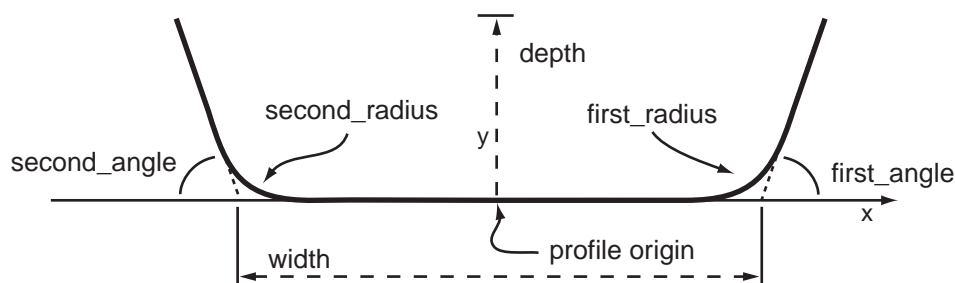


Figure 27 — Square\_u\_profile parameters

#### 4.2.324 Step

The Step application object is defined by clause 4.5 of ISO 14649-10:2004.

NOTE The ISO 14649 EXPRESS description for Step is shown below. Refer to ISO 14649-10 for the complete definition and explanation of usage.

```

ENTITY step
  SUBTYPE OF (machining_feature);
  open_boundary:      linear_path;
  wall_boundary:     OPTIONAL vee_profile;
  its_boss:          SET[0:?] OF boss;
END_ENTITY;

```

### 4.2.325 Step\_drill

The Step\_drill application object is defined by clause 4 of ISO 14649-111:—.

NOTE The ISO 14649 EXPRESS description for Step\_drill is shown below. Refer to ISO 14649-111 for the complete definition and explanation of usage.

```

ENTITY step_drill
  SUBTYPE OF (drilling_cutting_tool);
  diameters:      LIST [1:?] of length_measure;
  step_length:    LIST [1:?] of length_measure;
END_ENTITY;

```

### 4.2.326 Straight\_knurl

The Straight\_knurl application object is defined by clause 4.2 of ISO 14649-12:2005.

NOTE The ISO 14649 EXPRESS description for Straight\_knurl is shown below. Refer to ISO 14649-12 for the complete definition and explanation of usage.

```

ENTITY straight_knurl
  SUBTYPE OF (knurl);
END_ENTITY;

```

### 4.2.327 Straightness\_tolerance

A Straightness\_tolerance is a type of Geometric\_tolerance (see 4.2.156) that specifies the allowable variation that a curve or any curve on a surface may have from being a straight line. It defines a tolerance zone within which the curve shall lie.

NOTE This definition has been harmonized with the Straightness\_tolerance definitions in ISO 10303-1051, ISO 10303-214, and ISO 10303-224. This definition is derived from clause 14.1 of ISO 1101:2004. Figure 28 illustrates a Straightness\_tolerance.

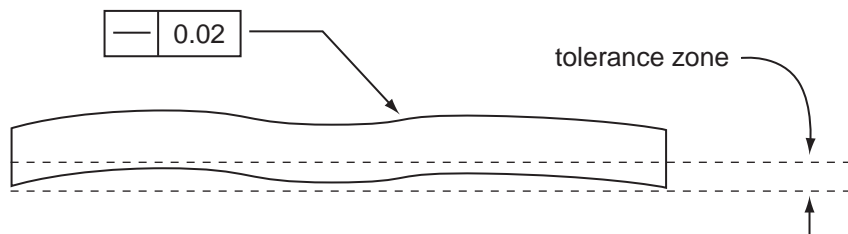


Figure 28 — Straightness\_tolerance

The data associated with a Straightness\_tolerance are the following:

- affected\_plane.

#### 4.2.327.1 affected\_plane

The affected\_plane specifies an axis placement, the X-Y plane of which establishes the plane in which the tolerance applies. The affected\_plane need not be specified for a particular Straightness\_tolerance.

#### 4.2.328 Supplier\_BSU

A Supplier\_BSU is a type of BSU (see 4.2.40) that identifies the supplier of a parts library.

NOTE This definition has been harmonized with the Supplier\_BSU definitions in ISO 10303-224 and ISO 10303-240.

#### 4.2.329 Surface\_profile\_tolerance

A Surface\_profile\_tolerance is a type of Geometric\_tolerance (see 4.2.156) that specifies a uniform boundary along an ideal profile within which the elements of a surface shall lie.

The tolerance zone established by a Surface\_profile\_tolerance is three dimensional, extending along the length and the width of the considered feature as a whole respectively along each segment of a defined size if the segment\_size attribute is specified. If the tolerance is to be unequally disposed about the theoretically exact feature, a Tolerance\_zone having only one boundary element is associated to the instance of Surface\_profile\_tolerance.

NOTE This definition has been harmonized with the Surface\_profile\_tolerance definitions in ISO 10303-1051, ISO 10303-214, and ISO 10303-224. This definition is derived from clause 14.6 of ISO 1101:2004. Figure 29 illustrates a Surface\_profile\_tolerance.

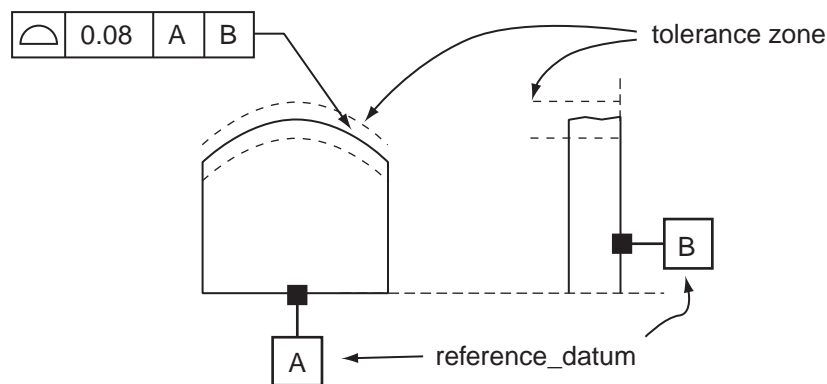


Figure 29 — Surface\_profile\_tolerance

ISO 10303-238:2007(E)

The data associated with a `Surface_profile_tolerance` are the following:

- `reference_datum`.

#### **4.2.329.1 reference\_datum**

The `reference_datum` specifies the set of `Datum_reference` objects that define the reference frame for the geometric tolerance. See 4.3.57 for the application assertion.

#### **4.2.330 Surface\_property**

A `Surface_property` is a type of `General_property` (see 4.2.151) that describes a specific characteristic about a surface condition of a Workpiece.

NOTE This definition has been harmonized with the `Surface_property` definitions in ISO 10303-224 and ISO 10303-240.

The data associated with a `Surface_property` are the following:

- `is_surface_finish`.
- `surface_characteristics`;

##### **4.2.330.1 is\_surface\_finish**

The `is_surface_finish` indicates whether or not the `Surface_property` is a surface finish.

##### **4.2.330.2 surface\_characteristics**

The `surface_characteristics` specifies the set of `Property_parameter` objects that describe the `Surface_property`. The `surface_characteristics` need not be specified for a particular `Surface_property`. See 4.3.58 for the application assertion.

#### **4.2.331 Surface\_texture\_parameter**

The `Surface_texture_parameter` application object is defined by clause 4.5 of ISO 14649-10:2004.

NOTE The ISO 14649 EXPRESS description for `Surface_texture_parameter` is shown below. Refer to ISO 14649-10 for the complete definition and explanation of usage.

```
ENTITY surface_texture_parameter;  
  its_value:           parameter_value;  
  parameter_name:     label;  
  measuring_method:   identifier;  
  parameter_index:    OPTIONAL identifier;  
  applied_surfaces:   SET [1:?] OF machined_surface;  
END_ENTITY;
```

### 4.2.332 Symmetry\_tolerance

A Symmetry\_tolerance is a type of Geometric\_tolerance (see 4.2.156) that specifies a constraint on the amount of deviation a tolerated element may have from being symmetrical to a datum. Any edge or (median) plane of the part shall lie in a tolerance zone limited by two parallel lines or planes, symmetrically located with respect to a datum.

NOTE This definition has been harmonized with the Symmetry\_tolerance definitions in ISO 10303-1051, ISO 10303-214, and ISO 10303-224. This definition is derived from clause 14.12 of ISO 1101:2004. Figure 30 illustrates a Symmetry\_tolerance.

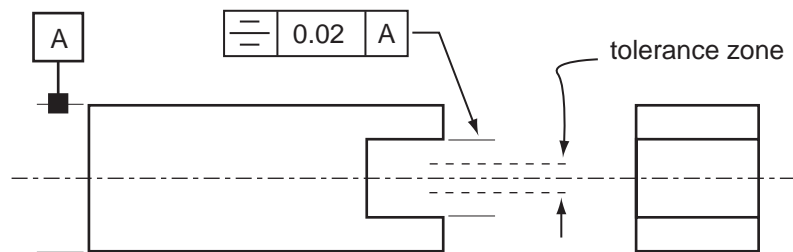


Figure 30 — Symmetry\_tolerance

The data associated with a Symmetry\_tolerance are the following:

- affected\_plane;
- reference\_datum.

#### 4.2.332.1 affected\_plane

The affected\_plane specifies an axis placement, the X-Y plane of which establishes the plane in which the tolerance applies. The affected\_plane need not be specified for a particular Symmetry\_tolerance.

#### 4.2.332.2 reference\_datum

The reference\_datum specifies the set of Datum\_reference objects that define the reference frame for the geometric tolerance. See 4.3.59 for the application assertion.

### 4.2.333 T\_slot\_mill

The T\_slot\_mill application object is defined by clause 4 of ISO 14649-111:—.

NOTE The ISO 14649 EXPRESS description for T\_slot\_mill is shown below. Refer to ISO 14649-111 for the complete definition and explanation of usage.

```
ENTITY t_slot_mill
  SUBTYPE OF (milling_cutting_tool);
  cutting_width: length_measure;
END_ENTITY;
```

### 4.2.334 Tapered\_drill

The Tapered\_drill application object is defined by clause 4 of ISO 14649-111:—.

NOTE The ISO 14649 EXPRESS description for Tapered\_drill is shown below. Refer to ISO 14649-111 for the complete definition and explanation of usage.

```
ENTITY tapered_drill
  SUBTYPE OF (twist_drill);
  taper_angle: plane_angle_measure;
END_ENTITY;
```

### 4.2.335 Tapered\_reamer

The Tapered\_reamer application object is defined by clause 4 of ISO 14649-111:—.

NOTE The ISO 14649 EXPRESS description for Tapered\_reamer is shown below. Refer to ISO 14649-111 for the complete definition and explanation of usage.

```
ENTITY tapered_reamer
  SUBTYPE OF (reaming_cutting_tool);
  taper_angle: plane_angle_measure;
END_ENTITY;
```

### 4.2.336 Tapping

The Tapping application object is defined by clause 4 of ISO 14649-11:2004.

NOTE The ISO 14649 EXPRESS description for Tapping is shown below. Refer to ISO 14649-11 for the complete definition and explanation of usage.

```
ENTITY tapping
  SUBTYPE OF (drilling_type_operation);
  compensation_chuck: BOOLEAN;
END_ENTITY;
```

### 4.2.337 Tapping\_cutting\_tool

The Tapping\_cutting\_tool application object is defined by clause 4 of ISO 14649-111:—.

NOTE The ISO 14649 EXPRESS description for Tapping\_cutting\_tool is shown below. Refer to ISO 14649-111 for the complete definition and explanation of usage.

```
ENTITY tapping_cutting_tool
  SUPERTYPE OF (combined_drill_and_tap)
  SUBTYPE OF (milling_machine_cutting_tool);
  thread_form_type: STRING;
  thread_size: length_measure;
  thread_pitch: REAL;
  taper_thread_count: REAL;
END_ENTITY;
```

### 4.2.338 Target\_area

A Target\_area is a type of Datum\_target (see 4.2.105) that specifies an area bounded by a closed shape element. The shape of the Target\_area is described explicitly by a set of curves with reference to the part coordinate system.

NOTE This definition has been harmonized with the Target\_area definitions in ISO 10303-1051, ISO 10303-214, and ISO 10303-224.

### 4.2.339 Target\_circle

A Target\_circle is a type of Placed\_target (see 4.2.239) that specifies a Datum\_target that is defined by an implicit circle. The location of the parameter\_reference is the centre of the circle, and the orientation of the Target\_circle is the X-Y plane of the parameter\_reference.

The data associated with a Target\_circle are the following:

- diameter.

#### 4.2.339.1 diameter

The diameter specifies the diameter of the Target\_circle.

### 4.2.340 Target\_point

A Target\_circle is a type of Placed\_target (see 4.2.239) that specifies a Datum\_target that is defined by a single implicit point. The position of the Target\_point is defined by the parameter\_reference.

NOTE This definition has been harmonized with the Target\_circle definitions in ISO 10303-1051, ISO 10303-214, and ISO 10303-224.

### 4.2.341 Target\_rectangle

A Target\_rectangle is a type of Placed\_target (see 4.2.239) that specifies a Datum\_target that is defined by an implicit rectangle. The location of the parameter\_reference is the centre of the rectangle, and the orientation of the Target\_rectangle is the X-Y plane with half the length of the rectangle in positive and half the length in negative direction along the X-axis and with half the width of the rectangle in positive and half the width in negative direction along the Y-axis.

NOTE This definition has been harmonized with the Target\_rectangle definitions in ISO 10303-1051, ISO 10303-214, and ISO 10303-224.

The data associated with a Target\_rectangle are the following:

- target\_length;
- target\_width.

### 4.2.341.1 target\_length

The target\_length specifies the length of the Target\_rectangle.

### 4.2.341.2 target\_width

The target\_width specifies the width of the Target\_rectangle.

### 4.2.342 Target\_straight\_line

A Target\_straight\_line is a type of Placed\_target (see 4.2.239) that specifies a Datum\_target that is defined by a straight line. The first end point of the line is specified by the location of the parameter\_reference. The second end point is located on the z-axis of the parameter\_reference at the specified distance.

NOTE This definition has been harmonized with the Target\_straight\_line definition in ISO 10303-1051 as well as the Target\_line definitions in ISO 10303-214 and ISO 10303-224.

The data associated with a Target\_straight\_line are the following:

— target\_length.

### 4.2.342.1 target\_length

The target\_length specifies the length of the Target\_straight\_line.

### 4.2.343 Technology

The Technology application object is defined by clause 4.7 of ISO 14649-10:2004.

NOTE The ISO 14649 EXPRESS description for Technology is shown below. Refer to ISO 14649-10 for the complete definition and explanation of usage.

```
ENTITY technology
  ABSTRACT SUPERTYPE;
  feedrate:          OPTIONAL speed_measure;
  feedrate_reference: tool_reference_point;
END_ENTITY;

TYPE tool_reference_point = ENUMERATION OF (tcp, ccp);
END_TYPE;
```

### 4.2.344 Tee\_profile

The Tee\_profile application object is defined by clause 4.5 of ISO 14649-10:2004.

NOTE The ISO 14649 EXPRESS description for Tee\_profile is shown below. Refer to ISO 14649-10 for the complete definition and explanation of usage.



```

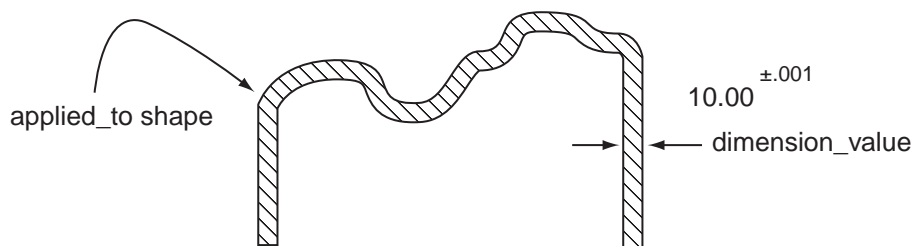
ENTITY tee_profile
  SUBTYPE OF (open_profile);
  first_angle:      plane_angle_measure;
  second_angle:     plane_angle_measure;
  cross_bar_width:  toleranced_length_measure;
  cross_bar_depth:  toleranced_length_measure;
  radius:           toleranced_length_measure;
  width:            toleranced_length_measure;
  first_offset:     toleranced_length_measure;
  second_offset:    toleranced_length_measure;
END_ENTITY;

```

### 4.2.345 Thickness\_size\_dimension

A Thickness\_size\_dimension is a type of Size\_dimension (see 4.2.313) that defines the allowable variation in the thickness of an element of the product shape.

NOTE This definition has been harmonized with the Thickness\_size\_dimension definitions in ISO 10303-1050 and ISO 10303-214, as well as the Thickness\_tolerance definition in ISO 10303-224. Figure 31 illustrates a Thickness\_size\_dimension.



**Figure 31 — Thickness\_size\_dimension**

EXAMPLE A Thickness\_size\_dimension might be used to describe the remaining thickness below a blind hole or the thickness of a coating layer.

The data associated with a Thickness\_size\_dimension are the following:

- used\_path.

#### 4.2.345.1 used\_path

The used\_path specifies a Measurement\_path along which the Thickness\_size\_dimension is measured. The used\_path need not be specified for a particular Thickness\_size\_dimension. See 4.3.60 for the application assertion.

### 4.2.346 Thread

The Thread application object is defined by clause 4.5 of ISO 14649-10:2004.

NOTE The ISO 14649 EXPRESS description for Thread is shown below. Refer to ISO 14649-10 for the complete definition and explanation of usage.

```

ENTITY thread
  ABSTRACT SUPERTYPE OF (ONEOF (catalogue_thread, defined_thread))
  SUBTYPE OF (machining_feature);
  partial_profile:      partial_area_definition;
  applied_shape:       SET[1:?] OF machining_feature;
  inner_or_outer_thread: BOOLEAN;
  qualifier:           OPTIONAL descriptive_parameter;
  fit_class:           descriptive_parameter;
  form:                descriptive_parameter;
  major_diameter:     length_measure;
  number_of_threads:  numeric_parameter;
  thread_hand:        descriptive_parameter;
WHERE
  WR1: ('ROUND_HOLE' IN TYPEOF (applied_shape)) OR
       ('CIRCULAR_CLOSED_SHAPE_PROFILE' IN TYPEOF (applied_shape)) OR
       ('BOSS' IN TYPEOF (applied_shape));
END_ENTITY;

```

### 4.2.347 Thread\_drilling

The Thread\_drilling application object is defined by clause 4 of ISO 14649-11:2004.

NOTE The ISO 14649 EXPRESS description for Thread\_drilling is shown below. Refer to ISO 14649-11 for the complete definition and explanation of usage.

```

ENTITY thread_drilling
  SUBTYPE OF (drilling_type_operation);
  helical_movement_on_forward:  BOOLEAN;
END_ENTITY;

```

### 4.2.348 Thread\_mill

The Thread\_mill application object is defined by clause 4 of ISO 14649-111:—.

NOTE The ISO 14649 EXPRESS description for Thread\_mill is shown below. Refer to ISO 14649-111 for the complete definition and explanation of usage.

```

ENTITY thread_mill
  SUBTYPE OF (milling_cutting_tool);
  thread_form_type:  STRING;
  thread_size:      length_measure;
  thread_pitch:     REAL;
END_ENTITY;

```

### 4.2.349 Thread\_strategy

The Thread\_strategy application object is defined by clause 4.4 of ISO 14649-12:2005.

NOTE The ISO 14649 EXPRESS description for Thread\_strategy is shown below. Refer to ISO 14649-12 for the complete definition and explanation of usage.

```

ENTITY thread_strategy
  SUBTYPE OF (turning_machining_strategy);
  cut_in_amount_function: thread_cut_depth_type;
  threading_direction: threading_direction_type;
  path_return_angle: OPTIONAL plane_angle_measure;
  lift_height: OPTIONAL length_measure;
END_ENTITY;

TYPE thread_cut_depth_type = ENUMERATION OF (
  constant_depth, variable_depth, constant_removal_amount);
END_TYPE;

TYPE threading_direction_type = ENUMERATION OF (
  left, right, center, left_zigzag, right_zigzag);
END_TYPE;

```

### 4.2.350 Threading

The Threading application object is defined by clause 4.4 of ISO 14649-12:2005.

NOTE The ISO 14649 EXPRESS description for Threading is shown below. Refer to ISO 14649-12 for the complete definition and explanation of usage.

```

ENTITY threading
  ABSTRACT SUPERTYPE OF (ONEOF(threading_rough, threading_finish))
  SUBTYPE OF (turning_machining_operation);
  allowance: OPTIONAL length_measure;
END_ENTITY;

```

### 4.2.351 Threading\_finish

The Threading\_finish application object is defined by clause 4.4 of ISO 14649-12:2005.

NOTE The ISO 14649 EXPRESS description for Threading\_finish is shown below. Refer to ISO 14649-12 for the complete definition and explanation of usage.

```

ENTITY threading_finish
  SUBTYPE OF (threading);
END_ENTITY;

```

### 4.2.352 Threading\_rough

The Threading\_rough application object is defined by clause 4.4 of ISO 14649-12:2005.

NOTE The ISO 14649 EXPRESS description for Threading\_rough is shown below. Refer to ISO 14649-12 for the complete definition and explanation of usage.

```

ENTITY threading_rough
  SUBTYPE OF (threading);
  WHERE
    WR1: EXISTS(SELF.allowance) AND (SELF.allowance >= 0.0);
END_ENTITY;

```

### 4.2.353 Three\_axes

The Three\_axes application object is defined by clause 4.7 of ISO 14649-10:2004.

NOTE The ISO 14649 EXPRESS description for Three\_axes is shown below. Refer to ISO 14649-10 for the complete definition and explanation of usage.

```
ENTITY three_axes
  SUBTYPE OF (tool_direction);
END_ENTITY;
```

### 4.2.354 Three\_axes\_tilted\_tool

The Three\_axes\_tilted\_tool application object is defined by clause 4 of ISO 14649-11:2004.

NOTE The ISO 14649 EXPRESS description for Three\_axes\_tilted\_tool is shown below. Refer to ISO 14649-11 for the complete definition and explanation of usage.

```
ENTITY three_axes_tilted_tool
  SUBTYPE OF (tool_direction_for_milling);
  its_tool_direction: direction;
END_ENTITY;
```

### 4.2.355 Through\_bottom\_condition

The Through\_bottom\_condition application object is defined by clause 4.5 of ISO 14649-10:2004.

NOTE The ISO 14649 EXPRESS description for Through\_bottom\_condition is shown below. Refer to ISO 14649-10 for the complete definition and explanation of usage.

```
ENTITY through_bottom_condition
  SUBTYPE OF (hole_bottom_condition);
END_ENTITY;
```

### 4.2.356 Through\_pocket\_bottom\_condition

The Through\_pocket\_bottom\_condition application object is defined by clause 4.5 of ISO 14649-10:2004.

NOTE The ISO 14649 EXPRESS description for Through\_pocket\_bottom\_condition is shown below. Refer to ISO 14649-10 for the complete definition and explanation of usage.

```
ENTITY through_pocket_bottom_condition
  SUBTYPE OF (pocket_bottom_condition);
END_ENTITY;
```

### 4.2.357 Through\_profile\_floor

The Through\_profile\_floor application object is defined by clause 4.5 of ISO 14649-10:2004.

NOTE The ISO 14649 EXPRESS description for `Through_profile_floor` is shown below. Refer to ISO 14649-10 for the complete definition and explanation of usage.

```
ENTITY through_profile_floor;
END_ENTITY;
```

### 4.2.358 Time\_measure

A `Time_measure` is a type of `Value_with_tolerance` (see 4.2.403) in which the `value_component` describes a time duration.

NOTE As defined in ISO 14649-10, `Time_measure` does not explicitly specify a unit. Instead, a default unit of seconds is defined for all time durations. This part of ISO 10303 extends `Time_measure` to allow units to be explicitly specified using the “unit” attribute inherited from `Value_with_unit`. In addition, this measure can be qualified with a tolerance using the “limitation” attribute inherited from `Value_with_tolerance`.

### 4.2.359 Tolerance\_condition

A `Tolerance_condition` specifies the material condition of a feature of size, which is its actual size with respect to its size tolerance.

NOTE The use of material conditions is defined in ISO 2692 [1].

#### 4.2.359.1 condition

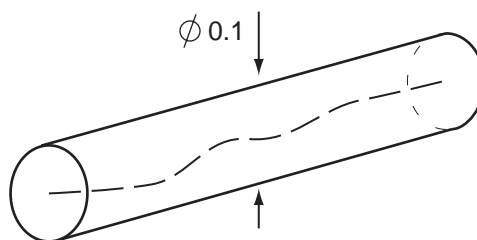
The condition specifies the kind of `Tolerance_condition`.

EXAMPLE Maximum material condition (MMC) and least material condition (LMC) are examples of conditions.

### 4.2.360 Tolerance\_zone

A `Tolerance_zone` is the zone wherein all points of the tolerated element shall fall.

EXAMPLE Figure 32 illustrates a `Tolerance_zone` of a `Straightness_tolerance` with `tolerance_value` ‘0.1’ specified for a line.



**Figure 32 — Tolerance\_zone**

The data associated with a `Tolerance_zone` are the following:

- `form_type`;
- `zone_for`.

#### **4.2.360.1 form\_type**

The `form_type` specifies the shape of the `Tolerance_zone`.

EXAMPLE 1 'cylindrical', 'parallelepiped', or 'spherical' are examples of `form_type`.

EXAMPLE 2 A `Surface_profile_tolerance` has a tolerance zone that is based on the profile of the feature. The `form_type` is 'profile'.

#### **4.2.360.2 zone\_for**

The `zone_for` specifies the set of `Geometric_tolerance` objects for which the `Tolerance_zone` defines the zone. See 4.3.61 for the application assertion.

#### **4.2.361 Tolerance\_zone\_definition**

A `Tolerance_zone_definition` is the specification of the boundaries of a `Tolerance_zone`. Each `Tolerance_zone_definition` may be a `Projection`.

The data associated with a `Tolerance_zone_definition` are the following:

- `defining`;
- `first_element`;
- `second_element`.

##### **4.2.361.1 defining**

The `defining` specifies the `Tolerance_zone` that is specified by the `Tolerance_zone_definition`. See 4.3.62 for the application assertion.

##### **4.2.361.2 first\_element**

The `first_element` specifies the shape element that represents the first or, in the case of a cylindrical tolerance zone, the only boundary of the `Tolerance_zone_definition`.

##### **4.2.361.3 second\_element**

The `second_element` specifies the shape element that represents the second bounding element. The `second_element` need not be specified for a particular `Tolerance_zone_definition`.

### 4.2.362 Toleranced\_length\_measure

A Toleranced\_length\_measure is a type of Value\_with\_tolerance (see 4.2.403) in which the value\_component describes a length.

NOTE As defined in ISO 14649-10, Toleranced\_length\_measure does not explicitly specify a unit. Instead, a default unit of millimeters is defined for all lengths. This part of ISO 10303 extends Toleranced\_length\_measure to allow units to be explicitly specified using the “unit” attribute inherited from Value\_with\_unit. In addition, the “theoretical\_size” attribute defined by ISO 14649-10 is now the “value\_component” attribute inherited from Value\_with\_unit, and the “implicit\_tolerance” attribute is now “limitation” inherited from Value\_with\_tolerance.

### 4.2.363 Tolerances

The Tolerances application object is defined by clause 4 of ISO 14649-11:2004.

NOTE The ISO 14649 EXPRESS description for Tolerances is shown below. Refer to ISO 14649-11 for the complete definition and explanation of usage.

```
ENTITY tolerances;
  chordal_tolerance:    length_measure;
  scallop_height:      length_measure;
END_ENTITY;
```

### 4.2.364 Tool\_direction

The Tool\_direction application object is defined by clause 4.7 of ISO 14649-10:2004.

NOTE The ISO 14649 EXPRESS description for Tool\_direction is shown below. Refer to ISO 14649-10 for the complete definition and explanation of usage.

```
ENTITY tool_direction
  ABSTRACT SUPERTYPE OF (ONEOF (two_axes, three_axes));
END_ENTITY;
```

### 4.2.365 Tool\_direction\_for\_milling

The Tool\_direction\_for\_milling application object is defined by clause 4 of ISO 14649-11:2004.

NOTE The ISO 14649 EXPRESS description for Tool\_direction\_for\_milling is shown below. Refer to ISO 14649-11 for the complete definition and explanation of usage.

```
ENTITY tool_direction_for_milling
  ABSTRACT SUPERTYPE OF (ONEOF(three_axes_tilted_tool, five_axes_var_tilt_yaw,
    five_axes_const_tilt_yaw))
  SUBTYPE OF (tool_direction);
END_ENTITY;
```

### 4.2.366 Tool\_knurl

The Tool\_knurl application object is defined by clause 4.2 of ISO 14649-12:2005.

NOTE The ISO 14649 EXPRESS description for Tool\_knurl is shown below. Refer to ISO 14649-12 for the complete definition and explanation of usage.

```
ENTITY tool_knurl
  SUBTYPE OF (knurl);
END_ENTITY;
```

### 4.2.367 Tool\_length\_probing

The Tool\_length\_probing application object is defined by clause 4.6 of ISO 14649-10:2004.

NOTE The ISO 14649 EXPRESS description for Tool\_length\_probing is shown below. Refer to ISO 14649-10 for the complete definition and explanation of usage.

```
ENTITY tool_length_probing
  SUBTYPE OF (tool_probing);
END_ENTITY;
```

### 4.2.368 Tool\_probing

The Tool\_probing application object is defined by clause 4.6 of ISO 14649-10:2004.

NOTE The ISO 14649 EXPRESS description for Tool\_probing is shown below. Refer to ISO 14649-10 for the complete definition and explanation of usage.

```
ENTITY tool_probing
  ABSTRACT SUPERTYPE OF (ONEOF (tool_length_probing, tool_radius_probing))
  SUBTYPE OF (touch_probing);
  offset:      cartesian_point;
  max_wear:    length_measure;
  its_tool:    machining_tool;
END_ENTITY;
```

### 4.2.369 Tool\_radius\_probing

The Tool\_radius\_probing application object is defined by clause 4.6 of ISO 14649-10:2004.

NOTE The ISO 14649 EXPRESS description for Tool\_radius\_probing is shown below. Refer to ISO 14649-10 for the complete definition and explanation of usage.

```
ENTITY tool_radius_probing
  SUBTYPE OF (tool_probing);
END_ENTITY;
```



### 4.2.370 Tool\_usage

A Tool\_usage specifies a physical cutting tool that satisfies tool requirements such as those set forth by an instance of Machining\_tool.

NOTE As one goes from higher level process descriptions (features and strategies) to lower level descriptions (explicit toolpaths), the tool requirements associated with an operation become increasingly specific. At some point, it is desirable to call out a specific tool to satisfy the requirements.

The data associated with a Tool\_usage are the following:

- its\_carousel;
- its\_id;
- its\_library\_reference;
- its\_position;
- its\_product.

#### 4.2.370.1 its\_carousel

The its\_carousel specifies a machine tool turret, magazine, or carousel. The its\_carousel need not be specified for a particular Tool\_usage.

#### 4.2.370.2 its\_id

The its\_id specifies a word or group of words which identify the Tool\_usage.

#### 4.2.370.3 its\_library\_reference

The its\_library\_reference specifies an Externally\_defined\_representation object that identifies the tool whose associated product information is provided within an external specification or document. The its\_library\_reference need not be specified for a particular Tool\_usage. See 4.3.64 for the application assertion.

EXAMPLE ISO 13399 [19] is one such external specification which describes various data about cutting tools and cutting tool assemblies, including reference dictionaries that describe tool properties.

#### 4.2.370.4 its\_position

The its\_position specifies a location within a machine tool turret, magazine, or carousel. The its\_position need not be specified for a particular Tool\_usage.

### 4.2.370.5 its\_product

The its\_product specifies a Workpiece object that describes the physical shape and associated product information of the tool. The its\_product need not be specified for a particular Tool\_usage. See 4.3.63 for the application assertion.

### 4.2.371 Toolpath

The Toolpath application object is defined by clause 4.8 of ISO 14649-10:2004. This part of ISO 10303 adds the following information requirements.

The data associated with a Toolpath are the following:

- all of the data defined by ISO 14649-10;
- its\_id.

NOTE The ISO 14649 EXPRESS description for Toolpath, as adapted by this part of ISO 10303, is shown below. Refer to ISO 14649-10 for the original definition and explanation of usage.

```

ENTITY toolpath
  ABSTRACT SUPERTYPE OF (ONEOF(feedstop, trajectory, parameterised_path));
  its_priority:          BOOLEAN;
  its_type:              toolpath_type;
  its_speed:             OPTIONAL toolpath_speedprofile;
  its_technology:        OPTIONAL technology;
  its_machine_functions: OPTIONAL machine_functions;
  its_id:                identifier; -- ADDED BY 10303-238
END_ENTITY;

TYPE toolpath_type = ENUMERATION OF (
  approach, lift, connect, non_contact, contact, trajectory_path);
END_TYPE;

TYPE toolpath_speedprofile = SELECT (
  toolpath_speed, positive_ratio_measure, speed_name);
END_TYPE;

TYPE speed_name = ENUMERATION OF (RAPID);
END_TYPE;

```

#### 4.2.371.1 its\_id

The its\_id specifies the string identifier of the Toolpath. The its\_id need not be specified for a particular Toolpath.

### 4.2.372 Toolpath\_feature

The Toolpath\_feature application object is defined by clause 4.5 of ISO 14649-10:2004.

NOTE The ISO 14649 EXPRESS description for Toolpath\_feature is shown below. Refer to ISO 14649-10 for the complete definition and explanation of usage.

```

ENTITY toolpath_feature
  SUBTYPE OF (machining_feature);
END_ENTITY;

```

### 4.2.373 Toolpath\_list

The Toolpath\_list application object is defined by clause 4.7 of ISO 14649-10:2004.

NOTE The ISO 14649 EXPRESS description for Toolpath\_list is shown below. Refer to ISO 14649-10 for the complete definition and explanation of usage.

```

ENTITY toolpath_list;
  its_list: LIST [1:?] OF toolpath;
END_ENTITY;

```

### 4.2.374 Toolpath\_speed

The Toolpath\_speed application object is defined by clause 4.8 of ISO 14649-10:2004. This part of ISO 10303 adds the following information requirements.

The data associated with a Toolpath\_speed are the following:

- all of the data defined by ISO 14649-10, as modified below for the speed attribute.

NOTE The ISO 14649 EXPRESS description for Toolpath\_speed, as adapted by this part of ISO 10303, is shown below. Refer to ISO 14649-10 for the original definition and explanation of usage.

```

ENTITY toolpath_speed;
  speed: bounded_curve; -- RELAXED BY 10303-238
WHERE
  WR1: speed\geometric_representation_item.dim = 1;
END_ENTITY;

```

#### 4.2.374.1 speed

The speed parameter is defined by ISO 14649-10 to be of type `b_spline_curve`, but this part of ISO 10303 relaxes this requirement so that the speed shall be of the more general type `bounded_curve`. All constraints on the parameterisation of the curve defined by ISO 14649-10 shall remain in effect. See 5.2.1.6.1 for additional discussion on the curve parameterization requirements.

NOTE This relaxation allows the use of simpler polyline speed curves already present in sources such as existing APT/CL data without forcing reparameterisation of the data into a more complicated B-spline curve. Because the parameterisation constraints remain in effect, the speed curve for a polyline basiccurve would be a polyline with the same distribution of points.

### 4.2.375 Topological\_region

The Topological\_region application object is defined by clause 4.5 of ISO 14649-10:2004.

NOTE The ISO 14649 EXPRESS description for `Topological_region` is shown below. Refer to ISO 14649-10 for the complete definition and explanation of usage.

```

ENTITY topological_region
  SUBTYPE OF (region, open_shell);
  WHERE
    WR1: SIZEOF(QUERY(it <* SELF.cfs_faces | NOT('ADVANCED_FACE' IN TYPEOF(it)))) = 0;
  END_ENTITY;

```

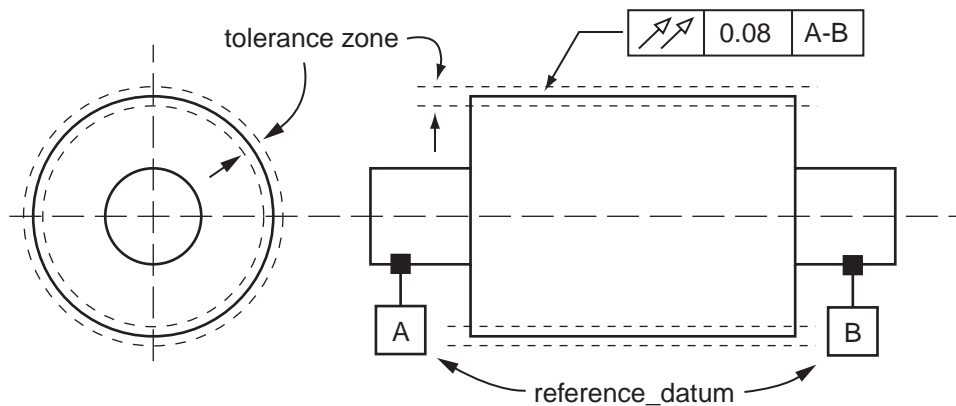
### 4.2.376 Total\_runout\_tolerance

A `Total_runout_tolerance` is a type of `Geometric_tolerance` (see 4.2.156) that specifies a constraint on a cylindrical surface with respect to a datum axis the part is rotated about. The tolerance is applied simultaneously to all positions as the part is rotated 360 degrees.

NOTE 1 Where applied to surfaces constructed around a datum axis, `Total_runout_tolerance` is used to control cumulative variations of circularity, straightness, coaxiality, angularity, taper, and profile of a surface.

NOTE 2 Where applied to surfaces constructed at right angles to a datum axis, `Total_runout_tolerance` controls cumulative variations or perpendicularity and flatness.

NOTE 3 This definition has been harmonized with the `Total_runout_tolerance` definitions in ISO 10303-1051, ISO 10303-214, and ISO 10303-224. This definition is derived from clause 14.13 of ISO 1101:2004. Figure 33 illustrates a `Total_runout_tolerance`.



**Figure 33 — Total\_runout\_tolerance**

The data associated with a `Total_runout_tolerance` are the following:

- angle;
- reference\_datum.

### 4.2.376.1 angle

The angle specifies the direction in which the runout tolerance is controlled. The angle need not be specified for a particular Total\_runout\_tolerance. If the angle is specified the runout tolerance applies for this angle. If not specified the runout tolerance applies normal to the shape element surface.

### 4.2.376.2 reference\_datum

The reference\_datum specifies the set of Datum\_reference objects that define the reference frame for the geometric tolerance. See 4.3.65 for the application assertion.

### 4.2.377 Touch\_probe

The Touch\_probe application object is defined by clause 4.6 of ISO 14649-10:2004.

NOTE The ISO 14649 EXPRESS description for Touch\_probe is shown below. Refer to ISO 14649-10 for the complete definition and explanation of usage.

```
ENTITY touch_probe;
  its_id: identifier;
END_ENTITY;
```

### 4.2.378 Touch\_probing

The Touch\_probing application object is defined by clause 4.6 of ISO 14649-10:2004.

NOTE The ISO 14649 EXPRESS description for Touch\_probing is shown below. Refer to ISO 14649-10 for the complete definition and explanation of usage.

```
ENTITY touch_probing
  ABSTRACT SUPERTYPE OF (ONEOF (workpiece_probing, workpiece_complete_probing,
    tool_probing))
  SUBTYPE OF (workingstep, operation);
  measured_offset: nc_variable;
END_ENTITY;
```

### 4.2.379 Trajectory

The Trajectory application object is defined by clause 4.8 of ISO 14649-10:2004. This part of ISO 10303 adds the following information requirements.

The data associated with a Trajectory are the following:

- all of the data defined by ISO 14649-10;
- its\_material\_removal\_depth;
- its\_material\_removal\_overcut;

— `its_material_removal_total_volume`.

NOTE The ISO 14649 EXPRESS description for Trajectory, as adapted by this part of ISO 10303, is shown below. Refer to ISO 14649-10 for the complete definition and explanation of usage.

```

ENTITY trajectory
  ABSTRACT SUPERTYPE OF (ONEOF(cutter_location_trajectory, cutter_contact_trajectory,
    axis_trajectory))
  SUBTYPE OF (toolpath);
  its_direction:          OPTIONAL BOOLEAN;
  its_material_removal_depth:  OPTIONAL material_removal_measure; -- ADDED BY 10303-238
  its_material_removal_overcut: OPTIONAL material_removal_measure; -- ADDED BY 10303-238
  its_material_removal_total_volume: OPTIONAL volume_measure;      -- ADDED BY 10303-238
END_ENTITY;

TYPE material_removal_curve = bounded_curve; END_TYPE;
TYPE material_removal_measure = SELECT (
  length_measure,
  material_removal_curve
);
END_TYPE;

```

#### 4.2.379.1 `its_material_removal_depth`

The `its_material_removal_depth` specifies the length of material removed at each point of the Trajectory as measured along the axis of the cutting tool. This may be specified as either a constant depth or as a one-dimensional curve specifying the depth at each point along the toolpath. The curve shall obey the same parameterization constraints as the “`its_speed`” data associated with a Toolpath (See 4.2.371). The `its_material_removal_depth` need not be specified for a particular Trajectory.

NOTE Machining strategies have cutting depth fields used as input to the toolpath generation process. The `its_material_removal_depth` and `its_material_removal_overcut` fields can describe how much material will be actually removed by each of the generated toolpaths so that adaptive controls can adjust feed and speed.

#### 4.2.379.2 `its_material_removal_overcut`

The `its_material_removal_overcut` specifies the length of material removed at each point of the Trajectory as measured perpendicular to the axis of the cutting tool. This may be specified as either a constant overcut or as a one-dimensional curve specifying the overcut at each point along the toolpath. The curve shall obey the same parameterization constraints as the “`its_speed`” data associated with a Toolpath (See 4.2.371). The `its_material_removal_overcut` need not be specified for a particular Trajectory.

#### 4.2.379.3 `its_material_removal_total_volume`

The `its_material_removal_total_volume` specifies the total volume of material removed by the Trajectory. The `its_material_removal_total_volume` need not be specified for a particular Trajectory.

## 4.2.380 Transition\_feature

The Transition\_feature application object is defined by clause 4.5 of ISO 14649-10:2004. This part of ISO 10303 adds the following information requirements.

NOTE 1 As described in 5.2.1.3.7, edge round and chamfer transition features can relate either two features or two sets of faces on the workpiece shape. At least one method is used, and both can be used if desired. In ISO 14649-10, first\_feature and second\_feature are defined as required attributes, so this clause relaxes the original definition to allow them to be omitted if the other method is used. The Chamfer (See 4.2.45) and Edge\_round (See 4.2.120) application objects describe the information requirements for the faces. In the AIM, the chamfer\_requires\_faces\_or\_features (See 5.2.4.4) and edge\_round\_requires\_faces\_or\_features (See 5.2.4.8) global rules enforce the use of at least one of the methods.

The data associated with a Transition\_feature are the following:

- all of the data defined by ISO 14649-10, as modified below for the first\_feature and second\_feature attributes.

NOTE 2 The ISO 14649 EXPRESS description for Transition\_feature, as adapted by this part of ISO 10303, is shown below. Refer to ISO 14649-10 for the original definition and explanation of usage.

```
ENTITY transition_feature
  ABSTRACT SUPERTYPE OF (ONEOF(chamfer, edge_round))
  SUBTYPE OF (manufacturing_feature);
  first_feature:      OPTIONAL machining_feature; -- RELAXED BY 10303-238
  second_feature:    OPTIONAL machining_feature; -- RELAXED BY 10303-238
END_ENTITY;
```

### 4.2.380.1 first\_feature

The first\_feature machining\_feature is required by ISO 14649-10, but this part of ISO 10303 relaxes this requirement so that the first\_feature need not be specified for a particular Transition\_feature.

### 4.2.380.2 second\_feature

The second\_feature machining\_feature is required by ISO 14649-10, but this part of ISO 10303 relaxes this requirement so that the second\_feature need not be specified for a particular Transition\_feature.

## 4.2.381 Travel\_path

The Travel\_path application object is defined by clause 4.5 of ISO 14649-10:2004.

NOTE The ISO 14649 EXPRESS description for Travel\_path is shown below. Refer to ISO 14649-10 for the complete definition and explanation of usage.

```
ENTITY travel_path
  ABSTRACT SUPERTYPE OF (ONEOF(general_path, linear_path, circular_path));
  placement:      OPTIONAL axis2_placement_3d;
END_ENTITY;
```

## 4.2.382 Turning\_feature

The Turning\_feature application object is defined by clause 4.2 of ISO 14649-12:2005.

NOTE The ISO 14649 EXPRESS description for Turning\_feature is shown below. Refer to ISO 14649-12 for the complete definition and explanation of usage.

```
ENTITY turning_feature
  ABSTRACT SUPERTYPE OF (ONEOF(outer_round, revolved_feature, knurl))
  SUBTYPE OF (two5D_manufacturing_feature);
END_ENTITY;
```

## 4.2.383 Turning\_machine\_cutting\_tool

The Turning\_machine\_cutting\_tool application object is defined by clause 4 of ISO 14649-121:2005.

NOTE The ISO 14649 EXPRESS description for Turning\_machine\_cutting\_tool is shown below. Refer to ISO 14649-121 for the complete definition and explanation of usage.

```
ENTITY turning_machine_cutting_tool
  SUBTYPE OF (machining_tool);
  functional_length:      length_measure;
  f_dimension:           length_measure;
  minimum_cutting_diameter:  OPTIONAL length_measure;
  a_dimension_on_f:      OPTIONAL length_measure;
  a_dimension_on_lf:     OPTIONAL length_measure;
  cutting_edge:          cutting_edge_properties;
  hand_of_tool:          OPTIONAL hand_of_tool_type;
END_ENTITY;

TYPE hand_of_tool_type = ENUMERATION OF (left,right,neutral);
END_TYPE;
```

## 4.2.384 Turning\_machine\_functions

The Turning\_machine\_functions application object is defined by clause 4.4 of ISO 14649-12:2005.

NOTE The ISO 14649 EXPRESS description for Turning\_machine\_functions is shown below. Refer to ISO 14649-12 for the complete definition and explanation of usage.

```
ENTITY turning_machine_functions
  SUBTYPE OF (machine_functions);
  coolant:              BOOLEAN;
  coolant_type:         OPTIONAL coolant_select;
  coolant_pressure:    OPTIONAL pressure_measure;
  axis_clamping:       LIST [0:?] OF identifier;
  chip_removal:        OPTIONAL BOOLEAN;
  oriented_spindle_stop:  OPTIONAL direction;
  its_process_model:    OPTIONAL process_model_list;
  other_functions:     SET [0:?] OF property_parameter;
  tail_stock:          OPTIONAL BOOLEAN;
  steady_rest:         OPTIONAL BOOLEAN;
  follow_rest:         OPTIONAL BOOLEAN;
END_ENTITY;
```



```

TYPE coolant_select = ENUMERATION OF (flood, mist, through_tool);
END_TYPE;

```

### 4.2.385 Turning\_machining\_operation

The Turning\_machining\_operation application object is defined by clause 4.4 of ISO 14649-12:2005.

NOTE The ISO 14649 EXPRESS description for Turning\_machining\_operation is shown below. Refer to ISO 14649-12 for the complete definition and explanation of usage.

```

ENTITY turning_machining_operation
  ABSTRACT SUPERTYPE OF (ONEOF(facing, grooving, contouring, threading, knurling))
  SUBTYPE OF (machining_operation);
  approach:          OPTIONAL approach_retract_strategy;
  retract:           OPTIONAL approach_retract_strategy;
  its_machining_strategy:  OPTIONAL turning_machining_strategy;
END_ENTITY;

```

### 4.2.386 Turning\_machining\_strategy

The Turning\_machining\_strategy application object is defined by clause 4.4 of ISO 14649-12:2005.

NOTE The ISO 14649 EXPRESS description for Turning\_machining\_strategy is shown below. Refer to ISO 14649-12 for the complete definition and explanation of usage.

```

ENTITY turning_machining_strategy
  ABSTRACT SUPERTYPE OF (ONEOF (unidirectional_turning, bidirectional_turning,
    thread_strategy, contour_turning, grooving_strategy, explicit_turning_strategy));
  overcut_length:    OPTIONAL length_measure;
  allow_multiple_passes:  OPTIONAL BOOLEAN;
  cutting_depth:     LIST[0:?] OF length_measure;
  variable_feedrate:  OPTIONAL positive_ratio_measure;
END_ENTITY;

```

### 4.2.387 Turning\_technology

The Turning\_technology application object is defined by clause 4.4 of ISO 14649-12:2005.

NOTE The ISO 14649 EXPRESS description for Turning\_technology is shown below. Refer to ISO 14649-12 for the complete definition and explanation of usage.

```

ENTITY turning_technology
  SUBTYPE OF (technology);
  spindle_speed:      speed_select;
  feed_per_revolution:  OPTIONAL feed_per_rev_type;
  sync_spindle_and_z_feed:  BOOLEAN;
  inhibit_feedrate_override:  BOOLEAN;
  inhibit_spindle_override:  BOOLEAN;
  its_adaptive_control:  OPTIONAL adaptive_control;
  WHERE
    WR1: (EXISTS(SELF.feedrate) AND
      NOT EXISTS(SELF.feed_per_revolution)) OR
      (NOT EXISTS(SELF.feedrate) AND EXISTS(SELF.feed_per_revolution));
END_ENTITY;

```

```
TYPE speed_select = SELECT (const_spindle_speed, const_cutting_speed);
END_TYPE;
```

### 4.2.388 Turning\_threading\_tool

The Turning\_threading\_tool application object is defined by clause 4 of ISO 14649-121:2005.

NOTE The ISO 14649 EXPRESS description for Turning\_threading\_tool is shown below. Refer to ISO 14649-121 for the complete definition and explanation of usage.

```
ENTITY turning_threading_tool
SUBTYPE OF (turning_machine_cutting_tool);
  threading_pitch:      length_measure;
  thread_hand:          thread_hand_type;
  its_thread_type:      thread_type;
  thread_profile:       thread_profile_type;
  thread_form_type:     STRING;
END_ENTITY;

TYPE thread_hand_type = ENUMERATION OF (left, right);
END_TYPE;

TYPE thread_type = ENUMERATION OF (internal, external);
END_TYPE;

TYPE thread_profile_type = ENUMERATION OF (full_profile, partial_profile);
END_TYPE;
```

### 4.2.389 Turning\_workingstep

The Turning\_workingstep application object is defined by clause 4.3 of ISO 14649-12:2005.

NOTE The ISO 14649 EXPRESS description for Turning\_workingstep is shown below. Refer to ISO 14649-12 for the complete definition and explanation of usage.

```
ENTITY turning_workingstep
SUBTYPE OF (workingstep);
  its_features:          LIST [2:?] OF manufacturing_feature;
  its_operation:         turning_machining_operation;
  its_effect:            OPTIONAL in_process_geometry;
END_ENTITY;
```

### 4.2.390 Twist\_drill

The Twist\_drill application object is defined by clause 4 of ISO 14649-111:—.

NOTE The ISO 14649 EXPRESS description for Twist\_drill is shown below. Refer to ISO 14649-111 for the complete definition and explanation of usage.

```
ENTITY twist_drill
SUPERTYPE OF (tapered_drill)
SUBTYPE OF (drilling_cutting_tool);
END_ENTITY;
```

### 4.2.391 Two5d\_manufacturing\_feature

The Two5d\_manufacturing\_feature application object is defined by clause 4.5 of ISO 14649-10:2004.

NOTE The ISO 14649 EXPRESS description for Two5d\_manufacturing\_feature is shown below. Refer to ISO 14649-10 for the complete definition and explanation of usage.

```
ENTITY two5D_manufacturing_feature
  ABSTRACT SUPERTYPE OF (ONEOF(machining_feature, replicate_feature, compound_feature))
  SUBTYPE OF (manufacturing_feature);
  feature_placement:      axis2_placement_3d;
END_ENTITY;
```

### 4.2.392 Two5d\_milling\_operation

The Two5d\_milling\_operation application object is defined by clause 4 of ISO 14649-11:2004.

NOTE The ISO 14649 EXPRESS description for Two5d\_milling\_operation is shown below. Refer to ISO 14649-11 for the complete definition and explanation of usage.

```
ENTITY two5D_milling_operation
  ABSTRACT SUPERTYPE OF (ONEOF(plane_milling, side_milling, bottom_and_side_milling))
  SUBTYPE OF (milling_type_operation);
  its_machining_strategy: OPTIONAL two5D_milling_strategy;
END_ENTITY;
```

### 4.2.393 Two5d\_milling\_strategy

The Two5d\_milling\_strategy application object is defined by clause 4 of ISO 14649-11:2004.

NOTE The ISO 14649 EXPRESS description for Two5d\_milling\_strategy is shown below. Refer to ISO 14649-11 for the complete definition and explanation of usage.

```
ENTITY two5D_milling_strategy
  ABSTRACT SUPERTYPE OF (ONEOF (unidirectional, bidirectional, contour_parallel,
    bidirectional_contour, contour_bidirectional, contour_spiral, center_milling,
    explicit_strategy));
  overlap:      OPTIONAL positive_ratio_measure;
  allow_multiple_passes: OPTIONAL BOOLEAN;
END_ENTITY;
```

### 4.2.394 Two\_axes

The Two\_axes application object is defined by clause 4.7 of ISO 14649-10:2004.

NOTE The ISO 14649 EXPRESS description for Two\_axes is shown below. Refer to ISO 14649-10 for the complete definition and explanation of usage.

```
ENTITY two_axes
  SUBTYPE OF (tool_direction);
END_ENTITY;
```

### 4.2.395 Unary\_boolean\_expression

The Unary\_boolean\_expression application object is defined by clause 4.6 of ISO 14649-10:2004.

NOTE The ISO 14649 EXPRESS description for Unary\_boolean\_expression is shown below. Refer to ISO 14649-10 for the complete definition and explanation of usage.

```
ENTITY unary_boolean_expression
  ABSTRACT SUPERTYPE OF(not_expression)
  SUBTYPE OF (boolean_expression);
  operand: boolean_expression;
END_ENTITY;
```

### 4.2.396 Unidirectional

The Unidirectional application object is defined by clause 4 of ISO 14649-11:2004.

NOTE The ISO 14649 EXPRESS description for Unidirectional is shown below. Refer to ISO 14649-11 for the complete definition and explanation of usage.

```
ENTITY unidirectional
  SUBTYPE OF (two5D_milling_strategy);
  feed_direction: OPTIONAL direction;
  cutmode: OPTIONAL cutmode_type;
END_ENTITY;
```

### 4.2.397 Unidirectional\_turning

The Unidirectional\_turning application object is defined by clause 4.4 of ISO 14649-12:2005.

NOTE The ISO 14649 EXPRESS description for Unidirectional\_turning is shown below. Refer to ISO 14649-12 for the complete definition and explanation of usage.

```
ENTITY unidirectional_turning
  SUBTYPE OF (turning_machining_strategy);
  feed_direction: OPTIONAL direction;
  back_path_direction: OPTIONAL direction;
  lift_direction: OPTIONAL direction;
  stepover_direction: OPTIONAL direction;
  lift_height: OPTIONAL length_measure;
  lift_feed: OPTIONAL feed_select;
  stepover_feed: OPTIONAL feed_select;
END_ENTITY;
```

### 4.2.398 Unload\_tool

The Unload\_tool application object is defined by clause 4 of ISO 14649-11:2004.

NOTE The ISO 14649 EXPRESS description for Unload\_tool is shown below. Refer to ISO 14649-11 for the complete definition and explanation of usage.

```
ENTITY unload_tool
```

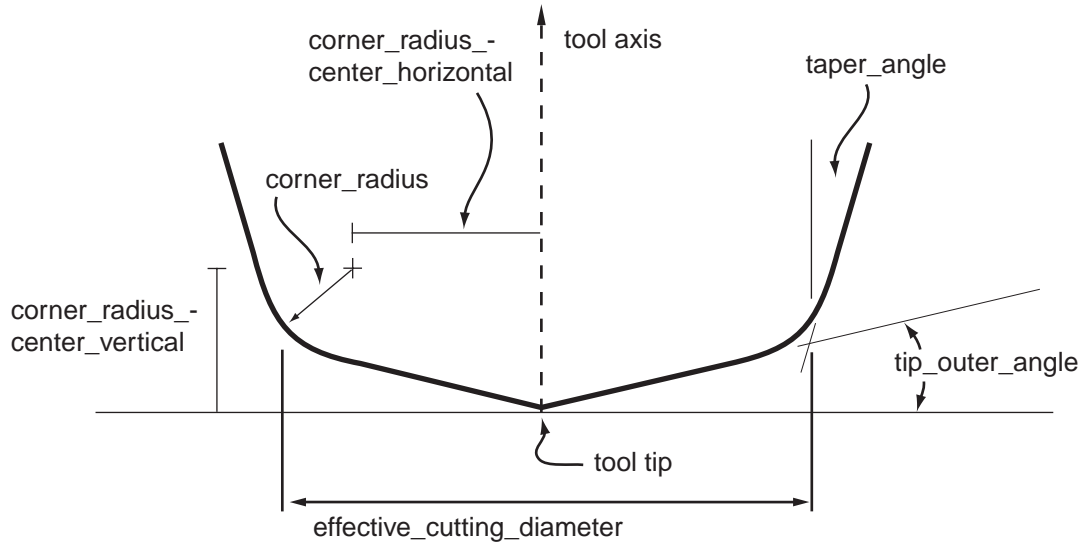
```

SUBTYPE OF (nc_function);
  its_tool:      OPTIONAL machining_tool;
END_ENTITY;

```

#### 4.2.399 User\_defined\_milling\_tool

A `User_defined_milling_tool` is a type of `Milling_machine_cutting_tool` whose characteristics are either not known or lie outside of the set of milling tools described by ISO 14649-111.



**Figure 34 — User\_defined\_milling\_tool parameters**

NOTE ISO 14649-121 provides the `User_defined_turning_tool` definition for equivalent use in turning applications. The tool dimension parameters described below are derived from the APT CUTTER definition and were present in earlier versions of ISO 14649-111.

The data associated with a `User_defined_milling_tool` are the following:

- `corner_radius`;
- `corner_radius_center_horizontal`;
- `corner_radius_center_vertical`;
- `description`;
- `taper_angle`;
- `tip_outer_angle`.

### **4.2.399.1 corner\_radius**

The `corner_radius` specifies the radius of the corner circle which describes the transition between the upper and lower line segments of the tool profile as shown in Figure 34.

### **4.2.399.2 corner\_radius\_center\_horizontal**

The `corner_radius_center_horizontal` specifies the radial distance from the tool axis to the centre of the corner circle. If positive, the corner circle and its centre are on the same side of the tool axis. If negative, the corner circle and its centre are on opposite sides of the tool axis.

### **4.2.399.3 corner\_radius\_center\_vertical**

The `corner_radius_center_vertical` specifies the distance from the tool endpoint to the centre of the corner circle measured parallel with the tool axis.

### **4.2.399.4 description**

The description specifies a word or group of words which characterize the tool.

### **4.2.399.5 taper\_angle**

The `taper_angle` specifies the angle between the upper line segment of the tool and the tool axis as shown in Figure 34.

NOTE This angle will be positive when the the tool diameter increases when moving from tip to spindle. The angle will be negative when the tool diameter decreases when moving from tip to spindle.

### **4.2.399.6 tip\_outer\_angle**

The `tip_outer_angle` specifies the angle between a radial line through the tool endpoint and the lower line segment of the tool as shown in Figure 34.

NOTE This angle is always acute (less than 90 degrees)

## **4.2.400 User\_defined\_turning\_tool**

The `User_defined_turning_tool` application object is defined by clause 4 of ISO 14649-121:2005.

NOTE The ISO 14649 EXPRESS description for `User_defined_turning_tool` is shown below. Refer to ISO 14649-121 for the complete definition and explanation of usage.

```
ENTITY user_defined_turning_tool
  SUBTYPE OF (turning_machine_cutting_tool);
  identifier: label;
END_ENTITY;
```

### 4.2.401 Uv\_strategy

The Uv\_strategy application object is defined by clause 4 of ISO 14649-11:2004.

NOTE The ISO 14649 EXPRESS description for Uv\_strategy is shown below. Refer to ISO 14649-11 for the complete definition and explanation of usage.

```
ENTITY uv_strategy
  SUBTYPE OF (freeform_strategy);
  forward_direction:    direction;
  sideward_direction:  direction;
END_ENTITY;
```

### 4.2.402 Value\_range

A Value\_range is a pair of numerical values representing the range in which the value shall lie.

The data associated with a Value\_range are the following:

- lower\_range;
- significant\_digits;
- upper\_range.

#### 4.2.402.1 lower\_range

The lower\_range specifies the lowest allowable value for a physical quantity.

#### 4.2.402.2 significant\_digits

The significant\_digits specify the number of decimal digits indicating the accuracy of the lower limit and upper limit values. The significant\_digits need not be specified for a particular Value\_range.

#### 4.2.402.3 upper\_range

The upper\_range specifies the highest allowable value for a physical quantity.

### 4.2.403 Value\_with\_tolerance

A Value\_with\_tolerance is a type of Value\_with\_unit (see 4.2.404) that qualifies the nominal value specified by Value\_with\_unit to specify the allowable variation of a physical quantity.

NOTE This application object is mapped to integrated definitions that have been harmonized across ISO 10303-1050, ISO 10303-214, and ISO 10303-224. The structure of the application object differs somewhat, due to the need in this part of ISO 10303 to combine both harmonized GD&T definitions as well as ISO 14649 concepts.

The data associated with a `Value_with_tolerance` are the following:

- `limitation`;
- `significant_digits`.

#### **4.2.403.1 limitation**

The `limitation` specifies the tolerance range, by either `Limit_qualifier`, `Limits_and_fits`, or `Plus_minus_value` for the physical quantity. The `limitation` need not be specified for a particular `Value_with_tolerance`. See 4.3.66, 4.3.67, and 4.3.68 for the application assertions.

#### **4.2.403.2 significant\_digits**

The `significant_digits` specifies the number of decimal digits indicating the accuracy of the physical quantity. The `significant_digits` need not be specified for a particular `Value_with_tolerance`.

#### **4.2.404 Value\_with\_unit**

A `Value_with_unit` is the specification of a physical quantity by its value and its unit.

NOTE This definition has been harmonized with the `Value_with_unit` definitions in ISO 10303-1054 [17].

The data associated with a `Value_with_unit` are the following:

- `unit`;
- `value_component`.

#### **4.2.404.1 unit**

The `unit` specifies the unit with which the physical quantity is expressed.

#### **4.2.404.2 value\_component**

The `value_component` specifies the numeric value of the quantity.

#### **4.2.405 Vee\_profile**

The `Vee_profile` application object is defined by clause 4.5 of ISO 14649-10:2004. This part of ISO 10303 adds the following information requirements.

The data associated with a `Vee_profile` are the following:

- all of the data defined by ISO 14649-10;
- `first_side_length`;



— `second_side_length`.

NOTE The ISO 14649 EXPRESS description for `Vee_profile`, as adapted by this part of ISO 10303, is shown below. Refer to ISO 14649-10 for the original definition and explanation of usage.

```

ENTITY vee_profile
  SUBTYPE OF (open_profile);
  profile_radius:      toleranced_length_measure;
  profile_angle:      plane_angle_measure;
  tilt_angle:         plane_angle_measure;
  first_side_length:  OPTIONAL toleranced_length_measure;  -- ADDED BY 10303-238
  second_side_length: OPTIONAL toleranced_length_measure;  -- ADDED BY 10303-238
END_ENTITY;

```

#### 4.2.405.1 first\_side\_length

The `first_side_length` indicates the distance, as measured from the profile origin, along the side of the vee located by the `tilt_angle` parameter. The `first_side_length` need not be specified for a particular `Vee_profile`.

#### 4.2.405.2 second\_side\_length

The `second_side_length` indicates the distance, as measured from the profile origin, along the side of the vee located by the sum of the `tilt_angle` and `profile_angle`. The `second_side_length` need not be specified for a particular `Vee_profile`.

NOTE Figure 35 illustrates the parameters associated with a `Vee_profile`. The `tilt_angle` is shown as the angle between the first side and the X axis as originally defined by ISO 10303-224. The ISO 14649-10 definition does not clearly specify which side this angle is measured from.

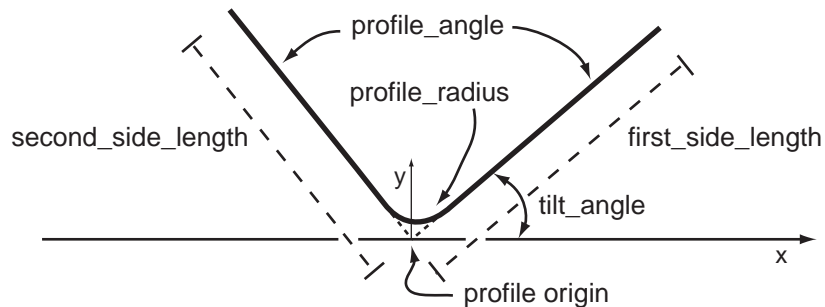


Figure 35 — `Vee_profile` parameters

#### 4.2.406 Volume\_measure

An `Volume_measure` is a type of `Value_with_tolerance` (see 4.2.403) in which the `value_component` describes a volume quantity.

#### 4.2.407 Wait\_for\_mark

The `Wait_for_mark` application object is defined by clause 4.6 of ISO 14649-10:2004.

NOTE The ISO 14649 EXPRESS description for `Wait_for_mark` is shown below. Refer to ISO 14649-10 for the complete definition and explanation of usage.

```
ENTITY wait_for_mark
  SUBTYPE OF (nc_function);
  its_channel: channel;
END_ENTITY;
```

#### 4.2.408 While\_statement

The `While_statement` application object is defined by clause 4.6 of ISO 14649-10:2004.

NOTE The ISO 14649 EXPRESS description for `While_statement` is shown below. Refer to ISO 14649-10 for the complete definition and explanation of usage.

```
ENTITY while_statement
  SUBTYPE OF (program_structure);
  condition: boolean_expression;
  body: executable;
END_ENTITY;
```

#### 4.2.409 Width\_size\_dimension

A `Width_size_dimension` is a type of `Size_dimension` (see 4.2.313) that defines the allowable variation in the width of an element of the product shape.

NOTE This definition has been harmonized with the `Width_size_dimension` definitions in ISO 10303-1050 and ISO 10303-214, as well as the `Width_dimension` definition in ISO 10303-224.

The data associated with a `Width_size_dimension` are the following:

- `used_path`.

##### 4.2.409.1 used\_path

The `used_path` specifies a `Measurement_path` along which the `Width_size_dimension` is measured. The `used_path` need not be specified for a particular `Width_size_dimension`. See 4.3.69 for the application assertion.

#### 4.2.410 Woodruff\_slot\_end\_type

The `Woodruff_slot_end_type` application object is defined by clause 4.5 of ISO 14649-10:2004.

NOTE The ISO 14649 EXPRESS description for `Woodruff_slot_end_type` is shown below. Refer to ISO 14649-10 for the complete definition and explanation of usage.

```
ENTITY woodruff_slot_end_type
  SUBTYPE OF (slot_end_type);
  radius: toleranced_length_measure;
END_ENTITY;
```

### 4.2.411 Workingstep

The Workingstep application object is defined by clause 4.6 of ISO 14649-10:2004.

NOTE The ISO 14649 EXPRESS description for Workingstep is shown below. Refer to ISO 14649-10 for the complete definition and explanation of usage.

```
ENTITY workingstep
  ABSTRACT SUPERTYPE OF (ONEOF (machining_workingstep, rapid_movement, touch_probing))
  SUBTYPE OF (executable);
  its_secplane: elementary_surface;
END_ENTITY;
```

### 4.2.412 Workpiece

The Workpiece application object is defined by clause 4.4 of ISO 14649-10:2004. This part of ISO 10303 adds the following information requirements.

The data associated with a Workpiece are the following:

- all of the data defined by ISO 14649-10, as modified below for the its\_geometry and its\_bounding\_geometry attributes;
- its\_approvals;
- its\_categories;
- its\_components;
- its\_datestamps;
- its\_orgs;
- its\_people;
- its\_related\_geometry;
- its\_timestamps;
- product\_approvals;
- product\_datestamps;
- product\_orgs;
- product\_people;
- product\_timestamps;
- revision\_approvals;

- revision\_datestamps;
- revision\_id;
- revision\_orgs;
- revision\_people;
- revision\_timestamps.

NOTE The ISO 14649 EXPRESS description for Workpiece, as adapted by this part of ISO 10303, is shown below. Refer to ISO 14649-10 for the original definition and explanation of usage.

```

ENTITY workpiece;
  its_id:          identifier;
  its_material:    OPTIONAL material;
  global_tolerance: OPTIONAL length_measure;
  its_rawpiece:    OPTIONAL workpiece;
  its_geometry:    OPTIONAL shape_representation; -- RELAXED BY 10303-238
  its_bounding_geometry: OPTIONAL bounding_geometry_select;
  clamping_positions: SET [0:?] OF cartesian_point;

  -- ADDED BY 10303-238, fields for PDM information
  its_approvals:    SET [0:?] OF approval;
  its_categories:   SET [0:?] OF STRING;
  its_components:   SET [0:?] OF workpiece_assembly_component;
  its_datestamps:   SET [0:?] OF assigned_date;
  its_orgs:         SET [0:?] OF assigned_organization;
  its_people:       SET [0:?] OF assigned_person;
  its_related_geometry: SET [0:?] OF shape_representation;
  its_timestamps:   SET [0:?] OF assigned_time;

  product_approvals: SET [0:?] OF approval;
  product_datestamps: SET [0:?] OF assigned_date;
  product_orgs:       SET [0:?] OF assigned_organization;
  product_people:     SET [0:?] OF assigned_person;
  product_timestamps: SET [0:?] OF assigned_time;

  revision_approvals: SET [0:?] OF approval;
  revision_datestamps: SET [0:?] OF assigned_date;
  revision_id:         OPTIONAL identifier;
  revision_orgs:       SET [0:?] OF assigned_organization;
  revision_people:     SET [0:?] OF assigned_person;
  revision_timestamps: SET [0:?] OF assigned_time;
END_ENTITY;

TYPE bounding_geometry_select = SELECT (
  block, right_circular_cylinder,
  advanced_brep_shape_representation,
  edge_based_wireframe_shape_representation, -- ADDED BY 10303-238
  faceted_brep_shape_representation, -- ADDED BY 10303-238
  geometrically_bounded_surface_shape_representation, -- ADDED BY 10303-238
  geometrically_bounded_wireframe_shape_representation, -- ADDED BY 10303-238
  manifold_surface_shape_representation, -- ADDED BY 10303-238
  non_manifold_surface_shape_representation, -- ADDED BY 10303-238
  shell_based_wireframe_shape_representation -- ADDED BY 10303-238
);
END_TYPE;

```

### 4.2.412.1 its\_geometry

The `its_geometry` parameter is defined by ISO 14649-10 to be of type `advanced_brep_shape_representation`, but this part of ISO 10303 relaxes this requirement so that `its_geometry` shall be of the more general type `shape_representation`.

NOTE This relaxation allows the use of shape representation types supported by other APs. In particular, the integrated representation allows the use of shapes described by AIC 501 (edge-based wireframe), AIC 502 (shell-based wireframe), AIC 507 (geometrically-bounded surfaces), AIC 508 (non-manifold surfaces), AIC 509 (manifold surfaces), AIC 510 (geometrically-bounded wireframe), and AIC 512 (faceted brep), as well as the original AIC 514 (advanced brep) descriptions.

### 4.2.412.2 its\_bounding\_geometry

The `its_bounding_geometry` parameter is defined by ISO 14649-10 to be of type `block`, `right_circular_cylinder`, or `advanced_brep_shape_representation`, but this part of ISO 10303 relaxes this requirement so that `its_bounding_geometry` may also be of type `edge_based_wireframe_shape_representation`, `faceted_brep_shape_representation`, `geometrically_bounded_surface_shape_representation`, `geometrically_bounded_wireframe_shape_representation`, `manifold_surface_shape_representation`, `non_manifold_surface_shape_representation`, or `shell_based_wireframe_shape_representation`.

NOTE This relaxation allows the use of shape representation types supported by other APs. In particular, the integrated representation allows the use of shapes described by AIC 501 (edge-based wireframe), AIC 502 (shell-based wireframe), AIC 507 (geometrically-bounded surfaces), AIC 508 (non-manifold surfaces), AIC 509 (manifold surfaces), AIC 510 (geometrically-bounded wireframe), and AIC 512 (faceted brep), as well as the original AIC 514 (advanced brep) descriptions.

### 4.2.412.3 its\_approvals

The `its_approvals` specifies the set of Approval objects that define the approval status of the manufacturing description of the revision given by the `revision_id` of the Workpiece. The `its_approvals` need not be specified for a particular Workpiece. See 4.3.70 for the application assertion.

### 4.2.412.4 its\_categories

The `its_categories` specifies the set of names that identify categories that apply to the Workpiece. The `its_categories` need not be specified for a particular Workpiece. Where applicable, the following values shall be used:

- `fixture`: the Workpiece object describes the geometry and associated product information of a machining fixture used in the production of other machined parts;
- `fixtured_workpiece`: the Workpiece object describes the geometry and associated product information of an assembly containing one or more fixtures and the final state of a machined part;
- `rawpiece`: the Workpiece object describes the initial state of a machined part;

- tool: the Workpiece object describes the geometry and associated product information of a machining tool;

NOTE A Workpiece object categorized as a tool can describe a specific tool chosen to fulfill the tool requirements called out by a Machining\_tool application object

- workpiece: the Workpiece object describes the final state of a machined part.

#### **4.2.412.5 its\_components**

The its\_components specifies the set of Workpiece\_assembly\_component objects that define the components of a Workpiece. The its\_components need not be specified for a particular Workpiece. See 4.3.85 for the application assertion.

#### **4.2.412.6 its\_datestamps**

The its\_datestamps specifies the set of Assigned\_date objects that define dates and associated roles that apply to the manufacturing description of the revision given by the revision\_id of the Workpiece. The its\_datestamps need not be specified for a particular Workpiece. See 4.3.73 for the application assertion.

#### **4.2.412.7 its\_orgs**

The its\_orgs specifies the set of Assigned\_organization objects that define organizations and associated roles that apply to the manufacturing description of the revision given by the revision\_id of the Workpiece. The its\_orgs need not be specified for a particular Workpiece. See 4.3.76 for the application assertion.

#### **4.2.412.8 its\_people**

The its\_people specifies the set of Assigned\_person objects that define people and associated roles that apply to the manufacturing description of the revision given by the revision\_id of the Workpiece. The its\_people need not be specified for a particular Workpiece. See 4.3.79 for the application assertion.

#### **4.2.412.9 its\_related\_geometry**

The its\_related\_geometry specifies the set of zero or more shape representations associated with the its\_geometry shape representation to form the entire shape of the workpiece.

NOTE This parameter has been added for harmonization with ISO 10303-203 and ISO 10303-214 shape description of a part composed of shape constructs of multiple types of shape\_representation. The most common usage is to specify the advanced brep shape of a workpiece as its\_related\_geometry while the its\_geometry simply contains an axis2\_placement\_3d.

#### **4.2.412.10 its\_timestamps**

The `its_timestamps` specifies the set of `Assigned_time` objects that define dates with times and associated roles that apply to the manufacturing description of the revision given by the `revision_id` of the Workpiece. The `its_timestamps` need not be specified for a particular Workpiece. See 4.3.82 for the application assertion.

#### **4.2.412.11 product\_approvals**

The `product_approvals` specifies the set of `Approval` objects that define approval status across all revisions of the Workpiece. The `product_approvals` need not be specified for a particular Workpiece. See 4.3.71 for the application assertion.

#### **4.2.412.12 product\_datestamps**

The `product_datestamps` specifies the set of `Assigned_date` objects that define dates and associated roles that apply across all revisions of the Workpiece. The `product_datestamps` need not be specified for a particular Workpiece. See 4.3.74 for the application assertion.

#### **4.2.412.13 product\_orgs**

The `product_orgs` specifies the set of `Assigned_organization` objects that define organizations and associated roles that apply across all revisions of the Workpiece. The `product_orgs` need not be specified for a particular Workpiece. See 4.3.77 for the application assertion.

#### **4.2.412.14 product\_people**

The `product_people` specifies the set of `Assigned_person` objects that define people and associated roles that apply across all revisions of the Workpiece. The `product_people` need not be specified for a particular Workpiece. See 4.3.80 for the application assertion.

#### **4.2.412.15 product\_timestamps**

The `product_timestamps` specifies the set of `Assigned_time` objects that define dates with times and associated roles that apply across all revisions of the Workpiece. The `product_timestamps` need not be specified for a particular Workpiece. See 4.3.83 for the application assertion.

#### **4.2.412.16 revision\_approvals**

The `revision_approvals` specifies the set of `Approval` objects that define the approval status of the revision given by the `revision_id` of the Workpiece. The `revision_approvals` need not be specified for a particular Workpiece. See 4.3.72 for the application assertion.

#### **4.2.412.17 revision\_datestamps**

The `revision_datestamps` specifies the set of `Assigned_date` objects that define dates and associated roles that apply to the revision given by the `revision_id` of the `Workpiece`. The `revision_datestamps` need not be specified for a particular `Workpiece`. See 4.3.75 for the application assertion.

#### **4.2.412.18 revision\_id**

The `revision_id` identifies the revision of the `Workpiece`. The `revision_id` need not be specified for a particular `Workpiece`.

#### **4.2.412.19 revision\_orgs**

The `revision_orgs` specifies the set of `Assigned_organization` objects that define organizations and associated roles that apply to the revision given by the `revision_id` of the `Workpiece`. The `revision_orgs` need not be specified for a particular `Workpiece`. See 4.3.78 for the application assertion.

#### **4.2.412.20 revision\_people**

The `revision_people` specifies the set of `Assigned_person` objects that define people and associated roles that apply to the revision given by the `revision_id` of the `Workpiece`. The `revision_people` need not be specified for a particular `Workpiece`. See 4.3.81 for the application assertion.

#### **4.2.412.21 revision\_timestamps**

The `revision_timestamps` specifies the set of `Assigned_time` objects that define dates with times and associated roles that apply to the revision given by the `revision_id` of the `Workpiece`. The `revision_timestamps` need not be specified for a particular `Workpiece`. See 4.3.84 for the application assertion.

#### **4.2.413 Workpiece\_assembly\_component**

A `Workpiece_assembly_component` specifies the usage of a `Workpiece` as a component in an assembly, along with the geometric placement of the `Workpiece` within the assembly.

The data associated with a `Workpiece_assembly_component` are the following:

- `component`;
- `originating_orientation`;
- `resulting_orientation`;
- `reference_designator`.



### 4.2.413.1 component

The component specifies the release date of the Workpiece\_assembly\_component. See 4.3.86 for the application assertion.

### 4.2.413.2 originating\_orientation

The originating\_orientation specifies the placement of the component prior to being positioned in an assembly.

### 4.2.413.3 resulting\_orientation

The resulting\_orientation specifies the placement of the component within an assembly.

### 4.2.413.4 reference\_designator

The reference\_designator specifies a distinctive code that identifies the usage of the component in an assembly. The reference\_designator need not be specified for a particular Workpiece\_assembly\_component.

## 4.2.414 Workpiece\_complete\_probing

The Workpiece\_complete\_probing application object is defined by clause 4.6 of ISO 14649-10:2004.

NOTE The ISO 14649 EXPRESS description for Workpiece\_complete\_probing is shown below. Refer to ISO 14649-10 for the complete definition and explanation of usage.

```
ENTITY workpiece_complete_probing
  SUBTYPE OF (touch_probing);
  its_workpiece:      workpiece;
  probing_distance:  toleranced_length_measure;
  its_probe:         touch_probe;
  computed_offset:   offset_vector;
END_ENTITY;
```

## 4.2.415 Workpiece\_probing

The Workpiece\_probing application object is defined by clause 4.6 of ISO 14649-10:2004.

NOTE The ISO 14649 EXPRESS description for Workpiece\_probing is shown below. Refer to ISO 14649-10 for the complete definition and explanation of usage.

```
ENTITY workpiece_probing
  SUBTYPE OF (touch_probing);
  start_position:    axis2_placement_3d;
  its_workpiece:     workpiece;
  its_direction:     direction;
  expected_value:    toleranced_length_measure;
  its_probe:         touch_probe;
END_ENTITY;
```

## 4.2.416 Workpiece\_setup

The Workpiece\_setup application object is defined by clause 4.6 of ISO 14649-10:2004.

NOTE The ISO 14649 EXPRESS description for Workpiece\_setup is shown below. Refer to ISO 14649-10 for the complete definition and explanation of usage.

```
ENTITY workpiece_setup;
  its_workpiece:      workpiece;
  its_origin:         axis2_placement_3d;
  its_offset:         OPTIONAL offset_vector;
  its_restricted_area: OPTIONAL restricted_area_select;
  its_instructions:   LIST [0:?] OF setup_instruction;
END_ENTITY;

TYPE restricted_area_select = SELECT (bounded_surface, bounding_geometry_select);
END_TYPE;
```

## 4.2.417 Workplan

The Workplan application object is defined by clause 4.6 of ISO 14649-10:2004. This part of ISO 10303 adds the following information requirements.

The data associated with a Workplan are the following:

- all of the data defined by ISO 14649-10;
- its\_minimum\_machine\_params.

NOTE The ISO 14649 EXPRESS description for Workplan, as adapted by this part of ISO 10303, is shown below. Refer to ISO 14649-10 for the original definition and explanation of usage.

```
ENTITY workplan
  SUBTYPE OF (program_structure);
  its_elements:      LIST[0:?] OF executable;
  its_channel:       OPTIONAL channel;
  its_setup:         OPTIONAL setup;
  its_effect:        OPTIONAL in_process_geometry;
  its_minimum_machine_params: OPTIONAL machine_parameters; -- ADDED BY 10303-238
WHERE
  WR1: SIZEOF(QUERY(it <* its_elements | it = SELF)) = 0;
END_ENTITY;
```

### 4.2.417.1 its\_minimum\_machine\_params

The its\_minimum\_machine\_params specifies a Machine\_parameters object which describe the minimum machine tool characteristics required to execute the workplan. The its\_minimum\_machine\_params need not be specified for a particular Workplan. See 4.3.87 for the application assertion.

## 4.2.418 Xor\_expression

The Xor\_expression application object is defined by clause 4.6 of ISO 14649-10:2004.

NOTE The ISO 14649 EXPRESS description for Xor\_expression is shown below. Refer to ISO 14649-10 for the complete definition and explanation of usage.

```
ENTITY xor_expression
  SUBTYPE OF (binary_boolean_expression);
END_ENTITY;
```

### 4.3 Application assertions

This subclause specifies the application assertions for the computerized numerical controllers application protocol. Application assertions specify the relationships between application objects, the cardinality of the relationships, and the rules required for the integrity and validity of the application objects and UoFs. The application assertions and their definitions are given below.

NOTE The application assertions specified below pertain only to the application objects defined by this part of ISO 10303. All assertions governing the relationships between application objects defined in ISO 14649 are specified in ISO 14649.

#### 4.3.1 Angularity\_tolerance to Datum\_reference

Each Angularity\_tolerance refers to one or two Datum\_reference objects as reference\_datum. Each Datum\_reference acts as reference\_datum for zero or more Angularity\_tolerance objects.

#### 4.3.2 Approval to Approval\_status

Each Approval has exactly one Approval\_status as status. Each Approval\_status is the status of one or more Approval.

#### 4.3.3 Approval\_relationship to Approval (as related\_approval)

Each Approval\_relationship has exactly one Approval as related\_approval. Each Approval is the related\_approval of zero or more Approval\_relationship.

#### 4.3.4 Approval\_relationship to Approval (as relating\_approval)

Each Approval\_relationship has exactly one Approval as relating\_approval. Each Approval is the relating\_approval of zero or more Approval\_relationship.

#### 4.3.5 Approving\_person\_organization to Approval

Each Approving\_person\_organization has exactly one Approval as authorized\_approval. Each Approval is the authorized\_approval of one or more Approving\_person\_organization.

#### 4.3.6 Boss to Linear\_path

Each Boss has exactly one Linear\_path as boss\_height. Each Linear\_path is the boss\_height of zero or more Boss.

#### **4.3.7 Circular\_runout\_tolerance to Datum\_reference**

Each Circular\_runout\_tolerance refers to one or two Datum\_reference objects as reference\_datum. Each Datum\_reference acts as reference\_datum for zero or more Circular\_runout\_tolerance objects.

#### **4.3.8 Class\_BSU to Supplier\_BSU**

Each Class\_BSU refers to exactly one Supplier\_BSU object as defined\_by. Each Supplier\_BSU acts as defined\_by for zero or more Class\_BSU objects.

#### **4.3.9 Coaxiality\_tolerance to Datum\_reference**

Each Coaxiality\_tolerance refers to one or two Datum\_reference objects as reference\_datum. Each Datum\_reference acts as reference\_datum for zero or more Coaxiality\_tolerance objects.

#### **4.3.10 Common\_datum to Single\_datum**

Each Common\_datum refers to two or more Single\_datum objects as made\_up\_by. Each Single\_datum is related to zero or more Common\_datum objects.

#### **4.3.11 Concentricity\_tolerance to Datum\_reference**

Each Concentricity\_tolerance refers to one or two Datum\_reference objects as reference\_datum. Each Datum\_reference acts as reference\_datum for zero or more Concentricity\_tolerance objects.

#### **4.3.12 Curved\_distance\_dimension to Measurement\_path**

Each Curved\_distance\_dimension has exactly one Measurement\_path as used\_path. Each Measurement\_path is the used\_path of zero or more Curved\_distance\_dimension.

#### **4.3.13 Datum\_defined\_by\_targets to Datum\_target**

Each Datum\_defined\_by\_targets refers to one or more Datum\_target objects as defined\_by. Each Datum\_target acts as target for zero or more Datum\_defined\_by\_targets objects.

#### **4.3.14 Datum\_reference to Datum**

Each Datum\_reference refers to exactly one Datum object as referenced\_datum. Each Datum acts as referenced\_datum for zero or more Datum\_reference objects.

#### **4.3.15 Externally\_defined\_representation to Library\_part\_assignment**

Each Externally\_defined\_representation refers to exactly one Library\_part\_assignment object as identified\_by. Each Library\_part\_assignment acts as identified\_by for zero or more Externally\_defined\_representation objects.

#### **4.3.16 Externally\_defined\_size\_dimension to Measurement\_path**

Each Externally\_defined\_size\_dimension has at most one Measurement\_path as used\_path. Each Measurement\_path is the used\_path of zero or more Externally\_defined\_size\_dimension.

#### **4.3.17 General\_property to General\_property**

Each General\_property refers to zero or more General\_property objects as related\_properties. Each General\_property is the related\_properties of one or more General\_property objects.

#### **4.3.18 General\_property to Specification**

Each General\_property refers to zero or more Specification objects as specifications. Each Specification is the specifications of zero or more General\_property objects.

#### **4.3.19 General\_property to Workpiece**

Each General\_property has zero or one Workpiece as owner. Each Workpiece is the owner of zero or more General\_property objects.

#### **4.3.20 Geometric\_dimension to Value\_range**

Each Geometric\_dimension has at most one Value\_range as dimension\_value. Each Value\_range is the dimension\_value of zero or more Geometric\_dimension.

#### **4.3.21 Geometric\_dimension to Value\_with\_tolerance**

Each Geometric\_dimension has at most one Value\_with\_tolerance as dimension\_value. Each Value\_with\_tolerance is the dimension\_value of zero or more Geometric\_dimension.

#### **4.3.22 Geometric\_tolerance to Tolerance\_condition**

Each Geometric\_tolerance has at most one Tolerance\_condition as modification. Each Tolerance\_condition is the dimension\_value of zero or more Geometric\_tolerance.

#### **4.3.23 Geometric\_tolerance\_relationship to Geometric\_tolerance (as relating)**

Each Geometric\_tolerance\_relationship has exactly one Geometric\_tolerance as relating. Each Geometric\_tolerance is the relating of zero or more Geometric\_tolerance\_relationship.

#### **4.3.24 Geometric\_tolerance\_relationship to Geometric\_tolerance (as related)**

Each Geometric\_tolerance\_relationship has exactly one Geometric\_tolerance as related. Each Geometric\_tolerance is the related of zero or more Geometric\_tolerance\_relationship.

#### **4.3.25 Height\_size\_dimension to Measurement\_path**

Each Height\_size\_dimension has at most one Measurement\_path as used\_path. Each Measurement\_path is the used\_path of zero or more Height\_size\_dimension.

#### **4.3.26 Last\_modified\_timestamp to Executable**

Each Last\_modified\_timestamp has zero or more Executable as items. Each Executable is the items of at most one Last\_modified\_timestamp.

#### **4.3.27 Last\_modified\_timestamp to Operation**

Each Last\_modified\_timestamp has zero or more Operation as items. Each Operation is the items of at most one Last\_modified\_timestamp.

#### **4.3.28 Last\_modified\_timestamp to Project**

Each Last\_modified\_timestamp has zero or more Project as items. Each Project is the items of at most one Last\_modified\_timestamp.

#### **4.3.29 Last\_modified\_timestamp to Toolpath**

Each Last\_modified\_timestamp has zero or more Toolpath as items. Each Toolpath is the items of at most one Last\_modified\_timestamp.

#### **4.3.30 Last\_modified\_timestamp to Workpiece**

Each Last\_modified\_timestamp has zero or more Workpiece as items. Each Workpiece is the items of at most one Last\_modified\_timestamp.

#### **4.3.31 Length\_size\_dimension to Measurement\_path**

Each Length\_size\_dimension has at most one Measurement\_path as used\_path. Each Measurement\_path is the used\_path of zero or more Length\_size\_dimension.

#### **4.3.32 Library\_part\_assignment to Class\_BSU**

Each Library\_part\_assignment refers to exactly one Class\_BSU object as definitional\_class\_bsu. Each Class\_BSU acts as value\_property\_bsu for zero or more Library\_part\_assignment objects.

#### **4.3.33 Library\_part\_assignment to Library\_property\_value**

Each Library\_part\_assignment refers to zero or more Library\_property\_value object as definitional\_property\_value\_pairs. Each Library\_property\_value acts as definitional\_property\_value\_pairs for zero or more Library\_part\_assignment objects.

#### **4.3.34 Library\_property\_value to Property\_BSU**

Each Library\_property\_value refers to exactly one Property\_BSU object as value\_property\_bsu. Each Property\_BSU acts as value\_property\_bsu for zero or more Library\_property\_value objects.

#### **4.3.35 Line\_profile\_tolerance to Datum\_reference**

Each Line\_profile\_tolerance refers to zero, one, two, or three Datum\_reference objects as reference\_datum. Each Datum\_reference acts as reference\_datum for zero or more Line\_profile\_tolerance objects.

#### **4.3.36 Machine\_parameters to Machine\_axis\_travel**

Each Machine\_parameters refers to zero or more Machine\_axis\_travel objects as axis\_travel. Each Machine\_axis\_travel acts as axis\_travel for one or more Machine\_parameters objects.

#### **4.3.37 Machining\_tool to Tool\_usage**

Each Machining\_tool refers to zero or one Tool\_usage objects as its\_usage. Each Tool\_usage acts as its\_usage for zero or more Machining\_tool objects.

#### **4.3.38 Machining\_workingstep to Manufacturing\_feature (as final\_features)**

Each Machining\_workingstep has zero or more Manufacturing\_feature as final\_features. Each Manufacturing\_feature is the final\_features of zero or more Machining\_workingstep.

#### **4.3.39 Material\_property to Hardness**

Each Material\_property refers to zero or more Hardness objects as material\_hardness. Each Hardness is the material\_hardness of one or more Material\_property objects.

#### **4.3.40 Material\_property to Property\_parameter**

Each Material\_property refers to zero or more Property\_parameter objects as material\_characteristics. Each Property\_parameter is the material\_characteristics of zero or more Material\_property objects.

#### **4.3.41 Milling\_machine\_functions to Machine\_axis\_constraint**

Each Milling\_machine\_functions has zero or more Machine\_axis\_constraint as axis\_constraints. Each Machine\_axis\_constraint is the axis\_constraints of at least one Milling\_machine\_functions.

#### **4.3.42 Parallelism\_tolerance to Datum\_reference**

Each Parallelism\_tolerance refers to one or two Datum\_reference objects as reference\_datum. Each Datum\_reference acts as reference\_datum for zero or more Parallelism\_tolerance objects.

#### **4.3.43 Part\_property to Property\_parameter**

Each Part\_property refers to zero or more Property\_parameter objects as part\_characteristics. Each Property\_parameter is the part\_characteristics of zero or more Part\_property objects.

#### **4.3.44 Perpendicularity\_tolerance to Datum\_reference**

Each Perpendicularity\_tolerance refers to one, two, or three Datum\_reference objects as reference\_datum. Each Datum\_reference acts as reference\_datum for zero or more Perpendicularity\_tolerance objects.

#### **4.3.45 Pocket to Linear\_path**

Each Pocket has exactly one Linear\_path as course\_of\_travel. Each Linear\_path is the course\_of\_travel of zero or more Pocket.

#### **4.3.46 Position\_tolerance to Datum\_reference**

Each Position\_tolerance refers to zero, one, two, or three Datum\_reference objects as reference\_datum. Each Datum\_reference acts as reference\_datum for zero or more Position\_tolerance objects.

#### **4.3.47 Process\_property to Property\_parameter**

Each Process\_property refers to zero or more Property\_parameter objects as process\_characteristics. Each Property\_parameter is the process\_characteristics of zero or more Process\_property objects.

#### **4.3.48 Property\_BSU to Class\_BSU**

Each Property\_BSU refers to exactly one Class\_BSU object as name\_scope. Each Class\_BSU acts as name\_scope for zero or more Property\_BSU objects.

#### **4.3.49 Round\_hole to Linear\_path**

Each Round\_hole has exactly one Linear\_path as course\_of\_travel. Each Linear\_path is the course\_of\_travel of zero or more Round\_hole.

#### **4.3.50 Security\_classification\_assignment to Executable**

Each Security\_classification\_assignment has zero or more Executable as items. Each Executable is the items of at most one Security\_classification\_assignment.

#### **4.3.51 Security\_classification\_assignment to Operation**

Each Security\_classification\_assignment has zero or more Operation as items. Each Operation is the items of at most one Security\_classification\_assignment.



#### **4.3.52 Security\_classification\_assignment to Project**

Each Security\_classification\_assignment has zero or more Project as items. Each Project is the items of at most one Security\_classification\_assignment.

#### **4.3.53 Security\_classification\_assignment to Security\_classification**

Each Security\_classification\_assignment has exactly one Security\_classification as classification. Each Security\_classification is the classification of one or more Security\_classification\_assignment.

#### **4.3.54 Security\_classification\_assignment to Toolpath**

Each Security\_classification\_assignment has zero or more Toolpath as items. Each Toolpath is the items of at most one Security\_classification\_assignment.

#### **4.3.55 Security\_classification\_assignment to Workpiece**

Each Security\_classification\_assignment has zero or more Workpiece as items. Each Workpiece is the items of at most one Security\_classification\_assignment.

#### **4.3.56 Single\_datum to Tolerance\_condition**

Each Single\_datum refers to zero or one Tolerance\_condition as modification. Each Tolerance\_condition acts as modification for zero or more Single\_datum objects.

#### **4.3.57 Surface\_profile\_tolerance to Datum\_reference**

Each Surface\_profile\_tolerance refers to zero, one, two, or three Datum\_reference objects as reference\_datum. Each Datum\_reference acts as reference\_datum for zero or more Surface\_profile\_tolerance objects.

#### **4.3.58 Surface\_property to Property\_parameter**

Each Surface\_property refers to zero or more Property\_parameter objects as surface\_characteristics. Each Property\_parameter is the surface\_characteristics of zero or more Surface\_property objects.

#### **4.3.59 Symmetry\_tolerance to Datum\_reference**

Each Symmetry\_tolerance refers to one, two, or three Datum\_reference objects as reference\_datum. Each Datum\_reference acts as reference\_datum for zero or more Symmetry\_tolerance objects.

#### **4.3.60 Thickness\_size\_dimension to Measurement\_path**

Each Thickness\_size\_dimension has at most one Measurement\_path as used\_path. Each Measurement\_path is the used\_path of zero or more Thickness\_size\_dimension.

#### **4.3.61 Tolerance\_zone to Geometric\_tolerance**

Each Tolerance\_zone has one or more Geometric\_tolerance objects as zone\_for. Each Geometric\_tolerance is related to zero or more Tolerance\_zone objects.

#### **4.3.62 Tolerance\_zone\_definition to Tolerance\_zone**

Each Tolerance\_zone\_definition has exactly one Tolerance\_zone as defining. Each Tolerance\_zone is related to zero or more Tolerance\_zone\_definition objects.

#### **4.3.63 Tool\_usage to Workpiece**

Each Tool\_usage refers to zero or one Workpiece objects as its\_product. Each Workpiece acts as its\_product for zero or more Tool\_usage objects.

#### **4.3.64 Tool\_usage to Externally\_defined\_representation**

Each Tool\_usage refers to zero or one Externally\_defined\_representation objects as its\_library\_reference. Each Externally\_defined\_representation acts as its\_library\_reference for zero or more Tool\_usage objects.

#### **4.3.65 Total\_runout\_tolerance to Datum\_reference**

Each Total\_runout\_tolerance refers to one or two Datum\_reference objects as reference\_datum. Each Datum\_reference acts as reference\_datum for zero or more Total\_runout\_tolerance objects.

#### **4.3.66 Value\_with\_tolerance to Limit\_qualifier**

Each Value\_with\_tolerance has at most one Limit\_qualifier as limitation. Each Limit\_qualifier is the limitation of zero or more Value\_with\_tolerance.

#### **4.3.67 Value\_with\_tolerance to Limits\_and\_fits**

Each Value\_with\_tolerance has at most one Limits\_and\_fits as limitation. Each Limits\_and\_fits is the limitation of zero or more Value\_with\_tolerance.

#### **4.3.68 Value\_with\_tolerance to Plus\_minus\_value**

Each Value\_with\_tolerance has at most one Plus\_minus\_value as limitation. Each Plus\_minus\_value is the limitation of zero or more Value\_with\_tolerance.

#### **4.3.69 Width\_size\_dimension to Measurement\_path**

Each Width\_size\_dimension has at most one Measurement\_path as used\_path. Each Measurement\_path is the used\_path of zero or more Width\_size\_dimension.

**4.3.70 Workpiece to Approval (as its\_approvals)**

Each Workpiece has zero or more Approval objects as its\_approvals. Each Approval is the its\_approvals of zero or more Workpiece.

**4.3.71 Workpiece to Approval (as product\_approvals)**

Each Workpiece has zero or more Approval objects as product\_approvals. Each Approval is the product\_approvals of zero or more Workpiece.

**4.3.72 Workpiece to Approval (as revision\_approvals)**

Each Workpiece has zero or more Approval objects as revision\_approvals. Each Approval is the revision\_approvals of zero or more Workpiece.

**4.3.73 Workpiece to Assigned\_date (as its\_datestamps)**

Each Workpiece has zero or more Assigned\_date objects as its\_datestamps. Each Assigned\_date is the its\_datestamps of zero or more Workpiece.

**4.3.74 Workpiece to Assigned\_date (as product\_datestamps)**

Each Workpiece has zero or more Assigned\_date objects as product\_datestamps. Each Assigned\_date is the product\_datestamps of zero or more Workpiece.

**4.3.75 Workpiece to Assigned\_date (as revision\_datestamps)**

Each Workpiece has zero or more Assigned\_date objects as revision\_datestamps. Each Assigned\_date is the revision\_datestamps of zero or more Workpiece.

**4.3.76 Workpiece to Assigned\_organization (as its\_orgs)**

Each Workpiece has zero or more Assigned\_organization objects as its\_orgs. Each Assigned\_organization is the its\_orgs of zero or more Workpiece.

**4.3.77 Workpiece to Assigned\_organization (as product\_orgs)**

Each Workpiece has zero or more Assigned\_organization objects as product\_orgs. Each Assigned\_organization is the product\_orgs of zero or more Workpiece.

**4.3.78 Workpiece to Assigned\_organization (as revision\_orgs)**

Each Workpiece has zero or more Assigned\_organization objects as revision\_orgs. Each Assigned\_organization is the revision\_orgs of zero or more Workpiece.

#### **4.3.79 Workpiece to Assigned\_person (as its\_people)**

Each Workpiece has zero or more Assigned\_person objects as its\_people. Each Assigned\_person is the its\_people of zero or more Workpiece.

#### **4.3.80 Workpiece to Assigned\_person (as product\_people)**

Each Workpiece has zero or more Assigned\_person objects as product\_people. Each Assigned\_person is the product\_people of zero or more Workpiece.

#### **4.3.81 Workpiece to Assigned\_person (as revision\_people)**

Each Workpiece has zero or more Assigned\_person objects as revision\_people. Each Assigned\_person is the revision\_people of zero or more Workpiece.

#### **4.3.82 Workpiece to Assigned\_time (as its\_timestamps)**

Each Workpiece has zero or more Assigned\_time objects as its\_timestamps. Each Assigned\_time is the its\_timestamps of zero or more Workpiece.

#### **4.3.83 Workpiece to Assigned\_time (as product\_timestamps)**

Each Workpiece has zero or more Assigned\_time objects as product\_timestamps. Each Assigned\_time is the product\_timestamps of zero or more Workpiece.

#### **4.3.84 Workpiece to Assigned\_time (as revision\_timestamps)**

Each Workpiece has zero or more Assigned\_time objects as revision\_timestamps. Each Assigned\_time is the revision\_timestamps of zero or more Workpiece.

#### **4.3.85 Workpiece to Workpiece\_assembly\_component**

Each Workpiece has zero or more Workpiece\_assembly\_component objects as its\_components. Each Workpiece\_assembly\_component is the its\_components of exactly one Workpiece.

#### **4.3.86 Workpiece\_assembly\_component to Workpiece**

Each Workpiece\_assembly\_component has exactly one Workpiece as component. Each Workpiece is the component of zero or more Workpiece\_assembly\_component.

#### **4.3.87 Workplan to Machine\_parameters**

Each Workplan refers to zero or one Machine\_parameters object as its\_minimum\_machine\_params. Each Machine\_parameters acts as its\_minimum\_machine\_params for zero or more Workplan objects.

## 5 Application interpreted model

### 5.1 Mapping table

This clause contains the mapping table that shows how each UoF and application object of this part of ISO 10303 (see clause 4) maps to one or more AIM constructs (see Annex A). The mapping table is organized in five columns.

**NOTE** It is customary to present mapping tables in alphabetical order by UoF name, however this part of ISO 10303 presents the mapping table in the same order as they appear in clause 4.1. This ordering matches the ordering of clauses in the ISO 14649 parts and is intended to simplify reference between these documents."

Column 1) Application element: Name of an application element as it appears in the application object definition in 4.2. Application object names are written in uppercase. Attribute names and assertions are listed after the application object to which they belong and are written in lower case.

Column 2) AIM element: Name of an AIM element as it appears in the AIM (see Annex A), the term "IDENTICAL MAPPING", or the term "PATH". AIM entities are written in lower case. Attribute names of AIM entities are referred to as <entity name>.<attribute name>. The mapping of an application element may result in several related AIM elements. Each of these AIM elements requires a line of its own in the table. The term 'IDENTICAL MAPPING' indicates that both application objects of an application assertion map to the same AIM element. The term 'PATH' indicates that the application assertion maps to the entire reference path.

Column 3) Source: For those AIM elements that are interpreted from the integrated resources or the application interpreted constructs, this is the number of the corresponding part of ISO 10303. For those AIM elements that are created for the purposes of this part of ISO 10303, this is the number of this part. Entities or types that are defined within the integrated resources have an AIC as the source reference if the use of the entity or type for the mapping is within the scope of the AIC.

Column 4) Rules: One or more numbers may be given that refer to rules that apply to the current AIM element or reference path. For rules that are derived from relationships between application objects, the same rule is referred to by the mapping entries of all the involved AIM elements. The expanded names of the rules are listed after the table.

Column 5) Reference path: To describe fully the mapping of an application object, it may be necessary to specify a reference path through several related AIM elements. The reference path column documents the role of an AIM element relative to the AIM element in the row succeeding it. Two or more such related AIM elements define the interpretation of the integrated resources that satisfies the requirement specified by the application object. For each AIM element that has been created for use within this part of ISO 10303, a reference path up to its supertype from an integrated resource is specified.

For the expression of reference paths and the relationships between AIM elements the following notational conventions apply:

- a) `[]`: enclosed section constrains multiple AIM elements or sections of the reference path are required to satisfy an information requirement;

- b)  $()$ : enclosed section constrains multiple AIM elements or sections of the reference path are identified as alternatives within the mapping to satisfy an information requirement;
- c)  $\{\}$ : enclosed section constrains the reference path to satisfy an information requirement;
- d)  $\diamond$ : enclosed section constrains at one or more required reference path;
- e)  $\|$ : enclosed section constrains the supertype entity;
- f)  $->$ : attribute references the entity or select type given in the following row;
- g)  $<-$ : entity or select type is referenced by the attribute in the following row;
- h)  $[i]$ : attribute is an aggregation of which a single member is given in the following row;
- i)  $[n]$ : attribute is an aggregation of which member n is given in the following row;
- j)  $=>$ : entity is a supertype of the entity given in the following row;
- k)  $<=>$ : entity is a subtype of the entity given in the following row;
- l)  $=$ : the string, select, or enumeration type is constrained to a choice or value;
- m)  $\backslash$ : the reference path expression continues on the next line.
- n)  $*$ : used in conjunction with braces to indicate that any number of relationship entity data types may be assembled in a relationship tree structure

**Table 1 — Mapping table for measure UoF**

Application element	AIM element	Source	Rules	Reference path
AREA_MEASURE	measure_representation_item	10303-45		<pre> measure_representation_item &lt;=   measure_with_unit { measure_with_unit.value_component -&gt;   measure_value   measure_value = area_measure   area_measure } </pre>
LENGTH_MEASURE	[length_measure_with_unit] [measure_representation_item]	10303-41 10303-45		<pre> length_measure_with_unit &lt;=   measure_with_unit =&gt; { measure_with_unit.value_component -&gt;   measure_value   measure_value = length_measure   length_measure } measure_representation_item &lt;=   representation_item </pre>
LIMITS_AND_FITS #1: if used as the limitation of a value_with_tolerance that is the dimension_value of a geometric_dimension #2: if otherwise See NOTE 1	#1: (limits_and_fits) #2: (qualified_representation_item)	10303-47 10303-45		

**Table 1 — Mapping table for measure UoF (continued)**

Application element	AIM element	Source	Rules	Reference path
deviation	#1: (limits_and_fits.form_variance) #2: (qualitative_uncertainty.uncertainty_value)	10303-47 10303-45		#1: (limits_and_fits limits_and_fits.form_variance)  #2: (qualified_representation_item qualified_representation_item.qualifiers[i] -> value_qualifier value_qualifier = uncertainty_qualifier { uncertainty_qualifier.measure_name = 'form variance' } uncertainty_qualifier => qualitative_uncertainty.uncertainty_value)
grade	#1: (limits_and_fits.grade) #2: (qualitative_uncertainty.uncertainty_value)	10303-47 10303-45		#1: (limits_and_fits limits_and_fits.grade)  #2: (qualified_representation_item qualified_representation_item.qualifiers[i] -> value_qualifier value_qualifier = uncertainty_qualifier { uncertainty_qualifier.measure_name = 'grade' } uncertainty_qualifier => qualitative_uncertainty.uncertainty_value)
its_fitting_type	#1: (limits_and_fits.zone_variance) #2: (qualitative_uncertainty.uncertainty_value)	10303-47 10303-45		#1: (limits_and_fits limits_and_fits.grade)  #2: (qualified_representation_item qualified_representation_item.qualifiers[i] -> value_qualifier value_qualifier = uncertainty_qualifier { uncertainty_qualifier.measure_name = 'zone variance' } uncertainty_qualifier => qualitative_uncertainty.uncertainty_value)



**Table 1 — Mapping table for measure UoF (continued)**

Application element	AIM element	Source	Rules	Reference path
LIMIT_QUALIFIER	qualified_representation_item	10303-45		
qualifier	type_qualifier.name	10303-45		qualified_representation_item qualified_representation_item.qualifiers[i] -> value_qualifier = type_qualifier type_qualifier { (type_qualifier.name = 'maximum') (type_qualifier.name = 'minimum') }
MASS_MEASURE	[mass_measure_with_unit] [measure_representation_item]	10303-41 10303-45		mass_measure_with_unit <= measure_with_unit => { measure_with_unit.value_component -> measure_value measure_value = mass_measure mass_measure } measure_representation_item <= representation_item
PLANE_ANGLE_MEASURE	[plane_angle_measure_with_unit] [measure_representation_item]	10303-41 10303-45		plane_angle_measure_with_unit <= measure_with_unit => { measure_with_unit.value_component -> measure_value measure_value = plane_angle_measure plane_angle_measure } measure_representation_item <= representation_item
PLUS_MINUS_VALUE #1: if used as the limitation of a value_with_tolerance that is the dimension_value of a geometric_dimension #2: if otherwise See NOTE 1	#1: (tolerance_value) #2: (qualified_representation_item)	10303-47 10303-45		

**Table 1 — Mapping table for measure UoF (continued)**

Application element	AIM element	Source	Rules	Reference path
lower_limit	#1: (measure_with_unit) #2: (standard_uncertainty.uncertainty_value)	10303-41 10303-45		#1: (tolerance_value tolerance_value.lower_bound -> measure_with_unit)  #2: (qualified_representation_item value_qualifier value_qualifier = uncertainty_qualifier { uncertainty_qualifier.measure_name = 'lower limit' } standard_uncertainty standard_uncertainty.uncertainty_value)
upper_limit	#1: (measure_with_unit) #2: (standard_uncertainty.uncertainty_value)	10303-41 10303-45		#1: (tolerance_value tolerance_value.upper_bound -> measure_with_unit)  #2: (qualified_representation_item value_qualifier value_qualifier = uncertainty_qualifier { uncertainty_qualifier.measure_name = 'upper limit' } standard_uncertainty standard_uncertainty.uncertainty_value)
PRESSURE_MEASURE	measure_representation_item	10303-45		measure_representation_item <= measure_with_unit { measure_with_unit.value_component -> measure_value measure_value = numeric_measure numeric_measure }

**Table 1 — Mapping table for measure UoF (continued)**

Application element	AIM element	Source	Rules	Reference path
ROT_SPEED_MEASURE	measure_representation_item	10303-45		measure_representation_item <= measure_with_unit { measure_with_unit.value_component -> measure_value measure_value = numeric_measure numeric_measure }
SPEED_MEASURE	measure_representation_item	10303-45		measure_representation_item <= measure_with_unit { measure_with_unit.value_component -> measure_value measure_value = numeric_measure numeric_measure }
TIME_MEASURE	[time_measure_with_unit] [measure_representation_item]	10303-41 10303-45		time_measure_with_unit <= measure_with_unit => { measure_with_unit.value_component -> measure_value measure_value = time_measure time_measure } measure_representation_item <= representation_item
TOLERANCED_LENGTH_MEASURE	[length_measure_with_unit] [measure_representation_item]	10303-41 10303-45		length_measure_with_unit <= measure_with_unit => { measure_with_unit.value_component -> measure_value measure_value = length_measure length_measure } measure_representation_item <= representation_item

**Table 1 — Mapping table for measure UoF (continued)**

Application element	AIM element	Source	Rules	Reference path
<p>VALUE_RANGE</p> <p>#1: if used as the dimension_value of a geometric_dimension</p> <p>#2: if otherwise</p> <p>See NOTE 2</p>	<p>#1:(shape_dimension_representation)</p> <p>#2:(value_range)</p>	<p>10303-47</p> <p>10303-238</p>		
<p>value_range to value_with_unit (as lower_range)</p>	<p>PATH</p>			<pre>#1: (shape_dimension_representation &lt;=   shape_representation &lt;=   representation.items[j] -&gt;   { representation_item.name = 'lower range' }   representation_item =&gt;   measure_representation_item)  #2: (value_range &lt;=   compound_representation_item   compound_representation_item.item_element -&gt;   set_representation_item   set_representation_item[j] -&gt;   { representation_item.name = 'lower limit' }   representation_item =&gt;   measure_representation_item)</pre>

**Table 1 — Mapping table for measure UoF (continued)**

Application element	AIM element	Source	Rules	Reference path
significant_digits	precision_qualifier.precision_value	10303-45		#1: (shape_dimension_representation <= shape_representation <= representation <= representation.items[i] -> representation_item => measure_representation_item <= measure_with_unit <= measure_qualification.qualified_measure measure_qualification measure_qualification.qualifiers[i] -> value_qualifier = precision_qualifier precision_qualifier precision_qualifier.precision_value)  #2: (value_range <= compound_representation_item <= representation_item => qualified_representation_item qualified_representation_item.qualifiers[i] -> value_qualifier value_qualifier = precision_qualifier precision_qualifier precision_qualifier.precision_value)

**Table 1 — Mapping table for measure UoF (continued)**

Application element	AIM element	Source	Rules	Reference path
<p>value_range to value_with_unit (as upper_range)</p> <p><b>VALUE_WITH_TOLERANCE</b></p> <p>#1: if significant_digits is specified, or if limitation is specified and either the limitation is limit_qualifier or the value_with_tolerance is not the dimension_value of a geometric_dimension</p> <p>#2: if otherwise</p> <p>See NOTE 1</p>	<p>PATH</p> <p>#1: [measure_representation_item] [qualified_representation_item]</p> <p>#2: measure_representation_item</p>			<p>#1: (shape_dimension_representation &lt;=&gt; shape_representation &lt;=&gt; representation.items[j] -&gt; representation_item.name = 'upper range') representation_item =&gt; measure_representation_item)</p> <p>#2: (value_range &lt;=&gt; compound_representation_item compound_representation_item.item_element -&gt; set_representation_item set_representation_item[j] -&gt; representation_item.name = 'upper limit' ) representation_item =&gt; measure_representation_item)</p> <p>#1: (measure_representation_item &lt;=&gt; representation_item =&gt; qualified_representation_item)</p> <p>#2: (measure_representation_item &lt;=&gt; representation_item)</p>

**Table 1 — Mapping table for measure UoF (continued)**

Application element	AIM element	Source	Rules	Reference path
<p>value_with_tolerance to plus_minus_value, limits_and_fits, or limit_qualifier (as limitation)</p> <p>#1: if value_with_tolerance is the dimension_value of a geometric dimension and limitation is plus_minus_value or limits_and_fits</p> <p>#2: if otherwise</p> <p>See NOTE 1</p>	<p>PATH</p>			<p>#1 (measure_representation_item &lt;= representation_item &lt;- representation.items[i] representation =&gt; shape_representation =&gt; shape_dimension_representation &lt;- dimensional_characteristic_representation dimensional_characteristic_representation.dimension -&gt; dimensional_characteristic (dimensional_characteristic = dimensional_size (dimensional_size &lt;-) (dimensional_characteristic = dimensional_location dimensional_location &lt;-) plus_minus_tolerance.toleranced_dimension plus_minus_tolerance.range -&gt; tolerance_method_definition (tolerance_method_definition = tolerance_value tolerance_value) (tolerance_method_definition = limits_and_fits limits_and_fits) )</p> <p>#2: (measure_representation_item &lt;= representation_item =&gt; qualified_representation_item)</p>
<p>significant_digits</p>	<p>precision_qualifier.precision_value</p>	<p>10303-45</p>		<p>measure_representation_item &lt;= representation_item =&gt; qualified_representation_item qualified_representation_item.qualifiers[i] -&gt; value_qualifier value_qualifier = precision_qualifier precision_qualifier.precision_value</p>

**Table 1 — Mapping table for measure UoF (continued)**

Application element	AIM element	Source	Rules	Reference path
VALUE_WITH_UNIT	measure_representation_item	10303-45		measure_representation_item <= measure_with_unit
unit	unit	10303-41	5, 6	measure_representation_item <= measure_with_unit measure_with_unit.unit_component -> unit
value_component	measure_value	10303-41		measure_with_unit measure_with_unit.value_component -> measure_value
VOLUME_MEASURE	measure_representation_item	10303-45		measure_representation_item <= measure_with_unit { measure_with_unit.value_component -> measure_value measure_value = volume_measure volume_measure }



**Table 2 — Mapping table for project UoF**

Application element	AIM element	Source	Rules	Reference path
PERSON_AND_ADDRESS	person	10303-41		
its_person	IDENTICAL MAPPING	10303-41		person <- personal_address.people[i] personal_address
its_address	personal_address	10303-41		
PROJECT	product_definition_formation	10303-41		product_definition_formation { product_definition_formation.of_product -> product => machining_project }
its_id	product.id	10303-41		product_definition_formation product_definition_formation.of_product -> product product.id
project to workplan (as main_workplan)	PATH			product_definition_formation <- product_definition.formation product_definition characterized_product_definition = product_definition characterized_product_definition <- process_product_association.defined_product process_product_association process_product_association.process -> product_definition_process <= action { action.name = 'machining' } action.chosen_method -> action_method => machining_process_executable => machining_workplan

**Table 2 — Mapping table for project UoF (continued)**

Application element	AIM element	Source	Rules	Reference path
project to workpiece (as its_workpieces)	PATH			<pre> product_definition_formation &lt;-   product_definition_formation   product_definition &lt;-     product_definition_relationship.relatng_product_definition     { product_definition_relationship =&gt;       machining_project_workpiece_relationship }     product_definition_relationship.related_product_definition -&gt;       product_definition                     </pre>
project to person_and_address (as its_owner)	PATH			<pre> product_definition_formation person_and_organization_item = product_definition_formation   person_and_organization_item &lt;-     applied_person_and_organization_assignment.items[i]     applied_person_and_organization_assignment &lt;=       person_and_organization_assignment       { person_and_organization_assignment.role -&gt;         person_and_organization_role         person_and_organization_role.name = 'owner' }     person_and_organization_assignment.-       assigned_person_and_organization -&gt;         person_and_organization         person_and_organization.the_person -&gt;           person                     </pre>
its_release	date_and_time	10303-41		<pre> product_definition_formation date_and_time_item = product_definition_formation   date_and_time_item &lt;-     applied_date_and_time_assignment.items[i]     applied_date_and_time_assignment &lt;=       date_and_time_assignment       { date_and_time_assignment.role -&gt;         date_time_role         date_time_role.name = 'release date' }     date_and_time_assignment.assigned_date_and_time -&gt;       date_and_time                     </pre>

**Table 2 — Mapping table for project UoF (continued)**

Application element	AIM element	Source	Rules	Reference path
project to approval (as its_status)	PATH			product_definition_formation approval_item = product_definition_formation approval_item <- applied_approval_assignment.items[i] applied_approval_assignment <= approval_assignment approval_assignment.assigned_approval -> approval

**Table 3 — Mapping table for workpiece UoF**

Application element	AIM element	Source	Rules	Reference path
DESCRIPTIVE_PARAMETER	descriptive_representation_item	10303-45		
descriptive_string	descriptive_representation_item.-description	10303-45		
GENERAL_PROPERTY	property_definition	10303-41		
description	property_definition.description	10303-41		
general_property to workpiece or shape_aspect (as owner) #1: if owner is a workpiece #2: if owner is a shape_aspect	PATH			property_definition property_definition.definition -> characterized_definition #1: (characterized_definition = characterized_product_definition characterized_product_definition product_definition) #2: (characterized_definition = shape_definition shape_definition shape_definition = shape_aspect shape_aspect)
general_property to general_property (as related_properties)	PATH			property_definition <- property_definition.relationship.relatng_property_definition property_definition.relationship property_definition.relationship.related_property_definition -> property_definition
general_property to specification (as specifications)	PATH			property_definition document_reference_item = property_definition document_reference_item <- applied_document_reference.items[i] applied_document_reference <= document_reference document_reference.assigned_document -> document

**Table 3 — Mapping table for workpiece UoF (continued)**

Application element	AIM element	Source	Rules	Reference path
HARDNESS	material_property_representation	10303-45		<pre> material_property_representation property_definition.dependent_environment-&gt; data_environment data_environment.name = 'hardness' }                     </pre>
high_value	measure_with_unit	10303-41		<pre> material_property_representation &lt;= property_definition_representation property_definition.used_representation-&gt; representation representation.items[i] -&gt; { representation_item =&gt; qualified_representation_item qualified_representation_item.qualifiers[i]-&gt; value_qualifier=type_qualifier type_qualifier type_qualifier.name='high value'} { representation_item.name = 'high value'} representation_item =&gt; measure_representation_item &lt;= measure_with_unit                     </pre>
low_value	measure_with_unit	10303-41		<pre> material_property_representation &lt;= property_definition_representation property_definition.used_representation-&gt; representation representation.items[i] -&gt; { representation_item =&gt; qualified_representation_item qualified_representation_item.qualifiers[i]-&gt; value_qualifier=type_qualifier type_qualifier type_qualifier.name='low value'} { representation_item.name = 'low value'} representation_item =&gt; measure_representation_item &lt;= measure_with_unit                     </pre>

**Table 3 — Mapping table for workpiece UoF (continued)**

Application element	AIM element	Source	Rules	Reference path
nominal	measure_with_unit	10303-41		<pre> material_property_representation &lt;= property_definition_representation property_definition_representation.used_representation-&gt; representation representation.items[i] -&gt; { representation_item =&gt; qualified_representation_item qualified_representation_item.qualifiers[i]-&gt; value_qualifier=type_qualifier type_qualifier type_qualifier.name='nominal'} { representation_item.name = 'nominal'} representation_item =&gt; measure_representation_item &lt;= measure_with_unit                     </pre>
scale	data_environment.description	10303-45		<pre> material_property_representation material_property_representation.dependent_environment-&gt; data_environment { (data_environment.description = 'brinell') (data_environment.description = 'rockwell') (data_environment.description = 'vickers') (data_environment.description) } data_environment.description                     </pre>
MANUFACTURING_FEATURE	shape_aspect	10303-41		
its_id	shape_aspect.name See NOTE 3			

**Table 3 — Mapping table for workpiece UoF (continued)**

Application element	AIM element	Source	Rules	Reference path
manufacturing_feature to workpiece (as its_workpiece)	PATH			shape_aspect shape_aspect.of_shape -> product_definition_shape <= property_definition property_definition.definition -> characterized_definition characterized_definition = characterized_product_definition characterized_product_definition characterized_product_definition = product_definition product_definition

**Table 3 — Mapping table for workpiece UoF (continued)**

Application element	AIM element	Source	Rules	Reference path
<p>manufacturing_feature to machining_operation (as its_operations)</p> <p>See NOTE 4. This attribute and the resulting path is redundant.</p>	<p>PATH</p>		<p>8</p>	<pre> shape_definition = shape_aspect shape_definition property_or_shape_select = shape_definition property_or_shape_select &lt;- process_property_association.property_or_shape process_property_association.process -&gt; property_process &lt;= action { action.name = 'machining' } action.chosen_method -&gt; { action_method =&gt; machining_feature_process } action_method &lt;- action_method_relationship.related_method action_method_relationship { action_method_relationship =&gt; machining_feature_relationship } action_method_relationship.related_method -&gt; { action_method =&gt; machining_workingstep } action_method &lt;- action_method_relationship.related_method action_method_relationship { action_method_relationship =&gt; machining_operation_relationship } action_method_relationship.related_method -&gt; { action_method =&gt; machining_operation </pre>



**Table 3 — Mapping table for workpiece UoF (continued)**

Application element	AIM element	Source	Rules	Reference path
<p>explicit_representation                      #1: preferred                      #2: alternate, compatible with observed                      AP 224 usage                      See NOTE 5</p>	<p>face</p>	<p>10303-42</p>		<pre> shape_definition = shape_aspect shape_definition characterized_definition = shape_definition characterized_definition &lt;- property_definition.definition property_definition represented_definition = property_definition represented_definition &lt;- property_definition_representation.definition property_definition_representation #1: { property_definition_representation =&gt; shape_definition_representation } property_definition_representation.used_representation -&gt; #1: ( { representation.name = 'explicit feature shape' } { representation =&gt; shape_representation } representation ) #2: (representation) representation.items[i] -&gt; representation_item =&gt; face                     </pre>
<p>MATERIAL</p>	<p>material_designation</p>	<p>10303-45</p>		
<p>standard_identifier</p>	<p>document.id</p>	<p>10303-41</p>		<pre> material_designation document_reference_item = material_designation document_reference_item &lt;- applied_document_reference.items[i] applied_document_reference &lt;= document_reference document_reference.assigned_document -&gt; document document.id                     </pre>
<p>material_identifier:</p>	<p>material_designation.name</p>	<p>10303-45</p>		

**Table 3 — Mapping table for workpiece UoF (continued)**

Application element	AIM element	Source	Rules	Reference path
material to property_parameter (as material_property)	PATH			material_designation <- material_designation_characterization.designation material_designation_characterization material_designation_characterization.property -> characterized_material_property characterized_material_property=material_property_representation material_property_representation <= property_definition_representation property_definition_representation.used_representation -> representation representation.items[i] -> representation_item
MATERIAL_PROPERTY	material_property	10303-45		material_property <= property_definition
material_property to property_parameter (as material_characteristics)	PATH			material_property <= property_definition represented_definition = property_definition represented_definition <- property_definition_representation.definition { property_definition_representation=> material_property_representation } property_definition_representation.used_representation -> representation representation.items[i] -> representation_item
material_property to hardness (as material_hardness)	PATH			material_property <= property_definition represented_definition = property_definition represented_definition <- property_definition_representation.definition property_definition_representation=> material_property_representation
NUMERIC_PARAMETER	measure_representation_item	10303-45		

**Table 3 — Mapping table for workpiece UoF (continued)**

Application element	AIM element	Source	Rules	Reference path
its_parameter_value	measure_value	10303-41		measure_representation_item <= measure_with_unit measure_with_unit.value_component -> measure_value
its_parameter_unit	unit	10303-41	5, 6	measure_representation_item <= measure_with_unit measure_with_unit.component -> unit
PART_PROPERTY	property_definition	10303-41		property_definition {property_definition.name = 'part property'}
part_property_to_property_parameter (as part_characteristics)	PATH			property_definition property_definition = represented_definition <- represented_definition <- property_definition_representation.definition property_definition_representation property_definition_representation.used_representation -> representation representation.items[i] -> representation_item
PROPERTY_PARAMETER	representation_item	10303-43		
parameter_name	representation_item.name	10303-43		
PROCESS_PROPERTY	property_definition	10303-41		property_definition {property_definition.name = 'process property'}

**Table 3 — Mapping table for workpiece UoF (continued)**

Application element	AIM element	Source	Rules	Reference path
process_property to property_parameter (as process_characteristics)	PATH			<pre> property_definition represented_definition = property_definition represented_definition&lt;- property_definition_representation.definition property_definition_representation property_definition_representation.used_representation -&gt; representation representation.items[i] -&gt; representation_item                     </pre>
process_name	representation.name	10303-43		<pre> property_definition property_definition = represented_definition represented_definition&lt;- property_definition_representation.definition property_definition_representation property_definition_representation.used_representation -&gt; representation representation.name                     </pre>
SURFACE_PROPERTY	property_definition	10303-41		<pre> property_definition {property_definition.name = 'surface property'}                     </pre>
is_surface_finish #1 if value is true #2 if value is false	property_definition.description			<pre> property_definition property_definition.description #1: (property_definition.description = 'surface finish') #2: (property_definition.description)                     </pre>
surface_property to property_parameter (as surface_characteristics)				<pre> property_definition property_definition = represented_definition represented_definition&lt;- property_definition_representation.definition property_definition_representation property_definition_representation.used_representation -&gt; representation representation.items[i] -&gt; representation_item                     </pre>

**Table 3 — Mapping table for workpiece UoF (continued)**

Application element	AIM element	Source	Rules	Reference path
WORKPIECE	product_definition	10303-41		
its_id	product.id	10303-41		product_definition product_definition.formation-> product_definition_formation product_definition_formation.of_product-> product product.id
workpiece to material (as its_material)	PATH			product_definition <- product_definition_relationship.relatng_product_definition {product_definition_relationship => product_definition_usage => make_from_usage_option} product_definition_relationship product_definition_relationship.related_product_definition-> product_definition characterized_product_definition = product_definition characterized_product_definition characterized_definition = characterized_product_definition characterized_definition <- material_designation.definitions[i] material_designation

**Table 3 — Mapping table for workpiece UoF (continued)**

Application element	AIM element	Source	Rules	Reference path
global_tolerance	length_measure_with_unit	10303-41		<pre> product_definition characterized_product_definition = product_definition characterized_product_definition characterized_definition = characterized_product_definition characterized_definition &lt;- property_definition.definition { property_definition.name = 'global_tolerance' } property_definition represented_definition = property_definition represented_definition &lt;- property_definition_representation.definition property_definition_representation property_definition_representation.used_representation -&gt; representation =&gt; shape_representation representation.items[i]-&gt; representation_item =&gt; measure_representation_item &lt;= measure_with_unit =&gt; length_measure_with_unit                     </pre>
workpiece to workpiece (as its_rawpiece)	PATH			<pre> product_definition &lt;- product_definition.relationship.relatng_product_definition {product_definition_relationship =&gt; product_definition_usage =&gt; make_from_usage_option} product_definition_relationship.related_product_definition -&gt; product_definition                     </pre>

**Table 3 — Mapping table for workpiece UoF (continued)**

Application element	AIM element	Source	Rules	Reference path
its_geometry	shape_representation	10303-41		<pre> product_definition characterized_product_definition = product_definition characterized_product_definition characterized_definition = characterized_product_definition characterized_definition &lt;- property_definition.definition { property_definition =&gt; product_definition_shape } property_definition represented_definition = property_definition represented_definition &lt;- property_definition_representation.definition {property_definition_representation =&gt; shape_definition_representation } property_definition_representation property_definition_representation.used_representation -&gt; representation =&gt; shape_representation { shape_representation =&gt; (advanced_brep_shape_representation) (edge_based_wireframe_shape_representation) (faceted_brep_shape_representation) (geometrically_bounded_surface_shape_representation) (geometrically_bounded_wireframe_shape_representation) (manifold_surface_shape_representation) (non_manifold_surface_shape_representation) (shell_based_wireframe_shape_representation) }                     </pre>

**Table 3 — Mapping table for workpiece UoF (continued)**

Application element	AIM element	Source	Rules	Reference path
<p>its_bounding_geometry</p> <p>#1: if bounding geometry is a block</p> <p>#2: if bounding geometry is a right_circular_cylinder</p> <p>#3: if bounding geometry is any other shape representation</p> <p>See NOTE 6</p>	<p>#1: block_shape_representation</p> <p>#2: cylindrical_shape_representation</p> <p>#3: (advanced_brep_shape_representation)</p> <p>(edge_based_wireframe_shape_representation)</p> <p>(faceted_brep_shape_representation)</p> <p>(geometrically_bounded_surface_shape_representation)</p> <p>(geometrically_bounded_wireframe_shape_representation)</p> <p>(manifold_surface_shape_representation)</p> <p>(non_manifold_surface_shape_representation)</p> <p>(shell_based_wireframe_shape_representation)</p>	<p>10303-238</p> <p>10303-238</p> <p>10303-514</p> <p>10303-501</p> <p>10303-512</p> <p>10303-507</p> <p>10303-510</p> <p>10303-509</p> <p>10303-508</p> <p>10303-502</p>		<pre> product_definition_relat.ing_product_definition {product_definition_relationship =&gt;   product_definition_usage =&gt;   make_from_usage_option} product_definition_relationship product_definition_relat.ing_product_definition -&gt;   product_definition characterized_product_definition = product_definition characterized_product_definition characterized_definition = characterized_product_definition characterized_definition &lt;-   product_definition property_definition.definition { property_definition =&gt; product_definition_shape } property_definition represented_definition = property_definition represented_definition &lt;- property_definition_representation.definition {property_definition_representation =&gt;   shape_definition_representation } property_definition_representation property_definition_representation property_definition_representation.used_representation -&gt;   representation =&gt;   shape_representation =&gt;   block_shape_representation =&gt;   #1: (shape_representation_with_parameters =&gt;     block_shape_representation)   #2: (shape_representation_with_parameters =&gt;     cylindrical_shape_representation)   #3: (advanced_brep_shape_representation)     (edge_based_wireframe_shape_representation)       (faceted_brep_shape_representation)     (geometrically_bounded_surface_shape_representation)     (geometrically_bounded_wireframe_shape_representation)     (manifold_surface_shape_representation)     (non_manifold_surface_shape_representation)     (shell_based_wireframe_shape_representation) </pre>



**Table 3 — Mapping table for workpiece UoF (continued)**

Application element	AIM element	Source	Rules	Reference path
clamping_positions	cartesian_point	10303-42		<pre> product_definition characterized_product_definition = product_definition characterized_product_definition characterized_definition = characterized_product_definition characterized_definition &lt;- property_definition.definition { property_definition.name = 'clamping position' } property_definition represented_definition = property_definition represented_definition &lt;- property_definition_representation.definition property_definition_representation property_definition_representation.used_representation -&gt; representation =&gt; shape_representation representation.items[i]-&gt; representation_item =&gt; geometric_representation_item =&gt; point =&gt; cartesian_point                     </pre>
workpiece to approval (as its_approvals)	PATH			<pre> product_definition approval_item = product_definition approval_item &lt;- applied_approval_assignment.items[i] applied_approval_assignment &lt;=&amp; approval_assignment approval_assignment.assigned_approval -&gt; approval                     </pre>

**Table 3 — Mapping table for workpiece UoF (continued)**

Application element	AIM element	Source	Rules	Reference path
its_categories	product_category.name	10303-41		<pre> product_definition product_definition.formatation -&gt; product_definition_formatation product_definition_formatation.of_product -&gt; product &lt;- product_related_product_category.products[i] product_related_product_category =&gt; product_category { (product_category.name = 'fixture') (product_category.name = 'fixtured workpiece') (product_category.name = 'rawpiece') (product_category.name = 'tool') (product_category.name = 'workpiece') (product_category.name) } product_category.name                     </pre>
workpiece to workpiece_assembly_component (as its_components)	PATH			<pre> product_definition &lt;- product_definition.relationship.relatng_product_definition product_definition_relationship =&gt; product_definition_usage =&gt; assembly_component_usage =&gt; next_assembly_usage_occurrence                     </pre>
workpiece to assigned_date (as its_datestamps)	PATH			<pre> product_definition date_item = product_definition date_item &lt;- applied_date_assignment.items[i] applied_date_assignment                     </pre>
workpiece to assigned_organization (as its_orgs)	PATH			<pre> product_definition organization_item = product_definition organization_item &lt;- applied_organization_assignment.items[i] applied_organization_assignment                     </pre>

**Table 3 — Mapping table for workpiece UoF (continued)**

Application element	AIM element	Source	Rules	Reference path
workpiece to assigned_person (as its_people)	PATH			<pre> product_definition person_and_organization_item = product_definition person_and_organization_item &lt;- applied_person_and_organization_assignment.items[i] applied_person_and_organization_assignment                     </pre>
its_related_geometry	shape_representation	10303-41		<pre> product_definition characterized_product_definition = product_definition characterized_product_definition characterized_definition = characterized_product_definition characterized_definition &lt;- property_definition.definition { property_definition =&gt; product_definition_shape } property_definition represented_definition = property_definition represented_definition &lt;- property_definition_representation.definition {property_definition_representation =&gt; shape_definition_representation } property_definition_representation property_definition_representation.used_representation -&gt; { representation =&gt; shape_representation } representation &lt;- representation_relationship.rep_1 { representation_relationship =&gt; shape_representation_relationship } representation_relationship representation_relationship.rep_2 -&gt; representation =&gt; shape_representation                     </pre>

**Table 3 — Mapping table for workpiece UoF (continued)**

Application element	AIM element	Source	Rules	Reference path
workpiece to assigned_time (as its_timestamps)	PATH			product_definition date_and_time_item = product_definition date_and_time_item <- applied_date_and_time_assignment.items[i] applied_date_and_time_assignment
workpiece to approval (as product_approvals)	PATH			product_definition product_definition_formation -> product_definition_formation product_definition_formation.of_product -> product approval_item = product approval_item <- applied_approval_assignment.items[i] applied_approval_assignment <= approval_assignment approval_assignment.assigned_approval -> approval
workpiece to assigned_date (as product_datestamps)	PATH			product_definition product_definition_formation -> product_definition_formation product_definition_formation.of_product -> product date_item = product date_item <- applied_date_assignment.items[i] applied_date_assignment

**Table 3 — Mapping table for workpiece UoF (continued)**

Application element	AIM element	Source	Rules	Reference path
workpiece to assigned_ organization (as product_orgs)	PATH			product_definition product_definition.formation -> product_definition_formation product_definition_formation.of_product -> product organization_item = product organization_item <- applied_organization_assignment.items[i] applied_organization_assignment
workpiece to assigned_person (as product_people)	PATH			product_definition product_definition.formation -> product_definition_formation product_definition_formation.of_product -> product person_and_organization_item = product person_and_organization_item <- applied_person_and_organization_assignment.items[i] applied_person_and_organization_assignment
workpiece to assigned_time (as product_timestamps)	PATH			product_definition product_definition.formation -> product_definition_formation product_definition_formation.of_product -> product date_and_time_item = product date_and_time_item <- applied_date_and_time_assignment.items[i] applied_date_and_time_assignment

**Table 3 — Mapping table for workpiece UoF (continued)**

Application element	AIM element	Source	Rules	Reference path
workpiece to approval (as revision_approvals)	PATH			product_definition product_definition.formation -> product_definition_formation approval_item = product_definition_formation approval_item <- applied_approval_assignment.items[i] applied_approval_assignment <= approval_assignment approval_assignment.assigned_approval -> approval
workpiece to assigned_date (as revision_datestamps)	PATH			product_definition product_definition.formation -> product_definition_formation date_item = product_definition_formation date_item <- applied_date_assignment.items[i] applied_date_assignment
revision_id	product_definition_formation.id	10303-41		product_definition product_definition.formation -> product_definition_formation product_definition_formation.id  See NOTE 7
workpiece to assigned_organization (as revision_orgs)	PATH			product_definition product_definition.formation -> product_definition_formation organization_item = product_definition_formation organization_item <- applied_organization_assignment.items[i] applied_organization_assignment

**Table 3 — Mapping table for workpiece UoF (continued)**

Application element	AIM element	Source	Rules	Reference path
workpiece to assigned_person (as revision_people)	PATH			product_definition product_definition.formation-> product_definition_formation person_and_organization_item = product_definition_formation person_and_organization_item <- person_and_organization_assignment.items[i] applied_person_and_organization_assignment
workpiece to assigned_time (as revision_timestamps)	PATH			product_definition product_definition.formation-> product_definition_formation date_and_time_item = product_definition_formation date_and_time_item <- applied_date_and_time_assignment.items[i] applied_date_and_time_assignment
WORKPIECE_ASSEMBLY - COMPONENT	next_assembly_usage_occurrence	10303-44		
component	PATH			next_assembly_usage_occurrence<=<= assembly_component_usage<=<= product_definition_usage<=<= product_definition_relationship product_definition_relationship.related_product_definition-> product_definition

**Table 3 — Mapping table for workpiece UoF (continued)**

Application element	AIM element	Source	Rules	Reference path
<p>originating_orientation</p> <p>#1: if component is placed using mapped_item</p> <p>#2: if component is placed using context_dependent_shape_representation</p> <p>See NOTE 8</p>	<p>axis2_placement_3d</p>	<p>10303-42</p>		<pre> next_assembly_usage_occurrence&lt;=   product_definition_relationship characterized_product_definition = product_definition_relationship characterized_definition = characterized_product_definition characterized_definition &lt;-   property_definition.definition   #1:(property_definition   {property_definition =&gt; product_definition_shape}   represented_definition = property_definition   represented_definition &lt;-   property_definition.definition   property_definition_representation   {property_definition_representation =&gt;   shape_definition_representation}   property_definition_representation.used_representation -&gt;   {representation =&gt; shape_representation}   representation   representation.items[i]-&gt;   mapped_item   mapped_item.mapping_source-&gt;   representation_map   representation_map.mapping_origin-&gt;   representation_definition =&gt; product_definition_shape &lt;-   context_dependent_shape_representation.-   represented_product_relation   context_dependent_shape_representation   context_dependent_shape_representation.representation_relation -&gt;   [ shape_representation_relationship ]   [ representation_relationship_with_transformation ]   representation_relationship_with_transformation.-   transformation_operator -&gt;   transformation   transformation = item_defined_transformation   item_defined_transformation   item_defined_transformation.item_1 -&gt;   representation_item=&gt; axis2_placement_3d                     </pre>



**Table 3 — Mapping table for workpiece UoF (continued)**

Application element	AIM element	Source	Rules	Reference path
<p>resulting_orientation</p> <p>#1: if component is placed using mapped_item</p> <p>#2: if component is placed using context_dependent_shape_representation</p> <p>See NOTE 8</p>	<p>axis2_placement_3d</p>	<p>10303-42</p>		<pre> next_assembly_usage_occurrence&lt;=   product_definition_relationship characterized_product_definition = product_definition_relationship characterized_definition = characterized_product_definition characterized_definition &lt;-   property_definition.definition   #1:(property_definition   {property_definition =&gt; product_definition_shape}   represented_definition = property_definition   represented_definition &lt;-   property_definition.definition   property_definition_representation   {property_definition_representation =&gt;   shape_definition_representation}   shape_definition_representation property_definition_representation.used_representation -&gt;   {representation =&gt; shape_representation}   representation   representation.items[i]-&gt;   mapped_item   mapped_item.mapping_target-&gt; #2: (property_definition =&gt; product_definition_shape &lt;-   context_dependent_shape_representation.-   represented_product_relation   context_dependent_shape_representation   context_dependent_shape_representation.relationship_relation -&gt;   [ shape_representation_relationship ]   [ representation_relationship_with_transformation ]   representation_relationship_with_transformation.-   transformation_operator -&gt;   transformation   transformation = item_defined_transformation   item_defined_transformation   item_defined_transformation.transform_item_2 -&gt; )   representation_item=&gt; axis2_placement_3d                     </pre>

**Table 3 — Mapping table for workpiece UoF (continued)**

Application element	AIM element	Source	Rules	Reference path
reference_designator	assembly_component_usage\ reference_designator	10303-44		next_assembly_usage_occurrence\ assembly_component_usage assembly_component_usage.reference_designator

**Table 4 — Mapping table for manufacturing features UoF**

Application element	AIM element	Source	Rules	Reference path
ANGLE_TAPER	taper	10303-522		<pre>taper &lt;=   shape_aspect   {shape_aspect.description = 'angle taper'}   {shape_aspect.of_shape-&gt;     product_definition_shape &lt;=       property_definition       property_definition.definition-&gt;         characterized_definition         characterized_definition         characterized_object =&gt;           characterized_object =&gt;             feature_component_definition }</pre>
angle	plane_angle_measure_with_unit	10303-41		<pre>taper &lt;=   shape_aspect   shape_definition = shape_aspect   shape_definition   characterized_definition = shape_definition   characterized_definition &lt;-     property_definition.definition     property_definition &lt;-       property_definition.definition       property_definition.definition       {property_definition_representation =&gt;         shape_definition_representation }     property_definition_representation     property_definition_representation.used_representation -&gt;       {representation =&gt;         shape_representation =&gt;           shape_representation_with_parameters }     representation     representation.items[i] -&gt;       {representation_item.name = 'taper angle' }       representation_item =&gt;         measure_representation_item &lt;=           measure_with_unit =&gt;             plane_angle_measure_with_unit</pre>

**Table 4 — Mapping table for manufacturing features UoF (continued)**

Application element	AIM element	Source	Rules	Reference path
BLIND_BOTTOM_CONDITION	hole_bottom	10303-522		<pre> hole_bottom &lt;=   shape_aspect   {(shape_aspect.description = 'conical')    (shape_aspect.description = 'flat')} (shape_aspect.description = 'flat with radius') (shape_aspect.description = 'flat with taper') (shape_aspect.description = 'spherical')}} {shape_aspect.of_shape -&gt;  product_definition_shape &lt;=   property_definition   property_definition.definition -&gt;   characterized_definition   characterized_definition = characterized_object   characterized_definition =&gt;   feature_component_definition} </pre>
BOSS	boss	10303-522		<pre> boss &lt;=   {feature_definition =&gt;    instantiated_feature} feature_definition &lt;=   characterized_object   {(characterized_object.description = 'circular')    (characterized_object.description = 'complex')} (characterized_object.description = 'rectangular')}} </pre>

**Table 4 — Mapping table for manufacturing features UoF (continued)**

Application element	AIM element	Source	Rules	Reference path
boss to closed_profile (as its_boundary)	PATH			<pre> boss &lt;=&lt; feature_definition &lt;= characterized_object #1: { (characterized_object.description = 'circular') #2: (characterized_object.description = 'complex') #3: (characterized_object.description = 'rectangular')} characterized_definition = characterized_object characterized_definition &lt;- property_definition.definition property_definition =&gt; product_definition_shape &lt;- shape_aspect.of_shape #1: { (shape_aspect.description = 'circular profile occurrence') #2: (shape_aspect.description = 'enclosed profile occurrence') #3: (shape_aspect.description = 'rectangular profile occurrence')} shape_aspect &lt;- shape_aspect_relationship.related_shape_aspect { shape_aspect_relationship =&gt; shape_defining_relationship } { shape_aspect_relationship.description = 'profile usage' } shape_aspect_relationship shape_aspect_relationship.relatng_shape_aspect -&gt; shape_aspect =&gt; #1: (circular_closed_profile) #2: (closed_path_profile) #2: (ngon_closed_profile) #3: (rectangular_closed_profile) </pre>

**Table 4 — Mapping table for manufacturing features UoF (continued)**

Application element	AIM element	Source	Rules	Reference path
slope	plane_angle_measure_with_unit	10303-41		<pre> boss &lt;= feature_definition &lt;= characterized_object characterized_definition = characterized_object characterized_definition &lt;- property_definition.definition property_definition =&gt; product_definition_shape &lt;- shape_aspect.of_shape {shape_aspect.description = 'change in boundary occurrence'} shape_aspect &lt;- shape_aspect.related_shape_aspect {shape_aspect.relationship =&gt; feature_component_relationship} {shape_aspect.relationship.description = 'taper usage'} shape_aspect.relationship shape_aspect.relationship.relatng_shape_aspect -&gt; {shape_aspect.description = 'angle taper'} shape_aspect =&gt; taper                     </pre> <p>NOTE See mapping for ANGLE_TAPER.angle for path from here to plane_angle_measure</p>

**Table 4 — Mapping table for manufacturing features UoF (continued)**

Application element	AIM element	Source	Rules	Reference path
boss to linear_profile (as boss_height)	PATH			<pre>                     boss &lt;=                     feature_definition &lt;=                     characterized_object                     characterized_definition = characterized_object                     characterized_definition &lt;-                     property_definition.definition                     property_definition =&gt;                     product_definition_shape &lt;-                     shape_aspect.of_shape                     { shape_aspect.description = 'boss height occurrence' }                     shape_aspect &lt;-                     shape_aspect.related_shape_aspect                     { shape_aspect.relationship =&gt;                     shape_defining_relationship }                     { shape_aspect.relationship.name = 'boss height' }                     { shape_aspect.relationship.description = \                     'path feature component usage' }                     shape_aspect.relationship                     shape_aspect.relationship.relatng_shape_aspect -&gt;                     { shape_aspect.description = 'linear' }                     shape_aspect =&gt;                     path_feature_component                     </pre>

**Table 4 — Mapping table for manufacturing features UoF (continued)**

Application element	AIM element	Source	Rules	Reference path
CATALOGUE_THREAD	externally_defined_feature_definition	10303-522		<pre> externally_defined_feature_definition &lt;=   [externally_defined_item   {externally_defined_item.item_id-&gt;     source_item     source_item = 'external thread'}   {externally_defined_item.source-&gt;     external_source     external_source.source_id-&gt;     source_item     source_item = 'external feature specification'}]   [{feature_definition =&gt;     instanced_feature}   feature_definition &lt;=   characterized_object   {characterized_object.description = 'thread'}] </pre>



**Table 4 — Mapping table for manufacturing features UoF (continued)**

Application element	AIM element	Source	Rules	Reference path
<p>catalogue_thread to specification (as documentation)</p> <p>#1: (if specification has zero constraints)</p> <p>#2: (if specification has one or more constraints)</p>	<p>PATH</p>			<p>#1: (externally_defined_feature_definition document_reference_item = externally_defined_feature_definition document_reference_item &lt;- applied_document_reference.items[i] applied_document_reference &lt;= document_reference document_reference.assigned_document -&gt; document) #2:( externally_defined_feature_definition document_reference_item = externally_defined_feature_definition document_reference_item &lt;- applied_document_usage_constraint_assignment.items[i] applied_document_usage_constraint_assignment &lt;= document_usage_constraint_assignment document_usage_constraint_assignment.- assigned_document_usage -&gt; document_usage_constraint document_usage_constraint.source-&gt; document) {document &lt;- document_representation_type.represented_document document_representation_type} {document =&gt; document_file &lt;= characterized_object}</p>
<p>CHAMFER</p>	<p>chamfer</p>	<p>10303-522</p>		<p>chamfer &lt;= transition_feature &lt;= shape_aspect</p>

**Table 4 — Mapping table for manufacturing features UoF (continued)**

Application element	AIM element	Source	Rules	Reference path
angle_to_plane	plane_angle_measure_with_unit	10303-41		<pre> chamfer &lt;=   transition_feature &lt;=     shape_aspect &lt;-       shape_aspect_relationship.relatng_shape_aspect       {shape_aspect_relationship =&gt;         feature_component_relationship}       shape_aspect_relationship shape_aspect_relationship.related_shape_aspect -&gt; { shape_aspect.description = 'second offset' } { shape_aspect =&gt;   chamfer_offset }   shape_aspect   shape_definition = shape_aspect   shape_definition characterized_definition = shape_definition characterized_definition &lt;-   property_definition.definition   property_definition &lt;-     property_definition.definition     { property_definition_representation.definition       shape_definition_representation =&gt;         shape_definition_representation }     property_definition_representation     property_definition_representation.used_representation -&gt;       {representation =&gt;         shape_representation =&gt;           shape_representation_with_parameters}           representation           representation.items[i] -&gt;             {representation_item.name = 'offset angle' }             representation_item =&gt;               measure_representation_item &lt;=                 measure_with_unit =&gt;                   plane_angle_measure_with_unit </pre>

**Table 4 — Mapping table for manufacturing features UoF (continued)**

Application element	AIM element	Source	Rules	Reference path
first_offset_amount	length_measure_with_unit	10303-41		<pre> chamfer &lt;=   transition_feature &lt;=     shape_aspect &lt;-       shape_aspect_relationship.relatng_shape_aspect       {shape_aspect_relationship =&gt;         feature_component_relationship}       shape_aspect_relationship shape_aspect_relationship.related_shape_aspect -&gt;   {shape_aspect.description = 'first offset' }   { shape_aspect =&gt;     chamfer_offset }     shape_aspect       shape_definition = shape_aspect         shape_definition characterized_definition = shape_definition characterized_definition &lt;-   property_definition.definition   property_definition &lt;-     property_definition_representation.definition     { property_definition_representation =&gt;       shape_definition_representation }       property_definition_representation property_definition_representation.used_representation -&gt;   {representation =&gt;     shape_representation =&gt;       shape_representation_with_parameters}       representation       representation.items[i] -&gt;         {representation_item.name = 'offset amount' }         representation_item =&gt;           measure_representation_item &lt;=             measure_with_unit =&gt;               length_measure_with_unit           </pre>

**Table 4 — Mapping table for manufacturing features UoF (continued)**

Application element	AIM element	Source	Rules	Reference path
chamfer_face	face	10303-42	3	<pre> chamfer &lt;=   transition_feature &lt;=     shape_aspect   shape_definition = shape_aspect   shape_definition characterized_definition = shape_definition characterized_definition &lt;-   property_definition.definition   property_definition &lt;-   property_definition_representation.definition { property_definition_representation =&gt;   shape_definition_representation } property_definition_representation property_definition_representation.used_representation -&gt; { representation =&gt;   shape_representation=&gt;   face_shape_representation } representation {representation.name = 'chamfer face'} representation.items[i] -&gt;   representation_item =&gt; topological_representation_item =&gt;   face                     </pre>

**Table 4 — Mapping table for manufacturing features UoF (continued)**

Application element	AIM element	Source	Rules	Reference path
first_face_shape	face	10303-42	3	<pre> chamfer &lt;=   transition_feature &lt;=     shape_aspect &lt;-       shape_aspect.relationship.relatng_shape_aspect       {shape_aspect_relationship =&gt;         feature_component_relationship}       shape_aspect_relationship shape_aspect_relationship.related_shape_aspect -&gt;   {shape_aspect.description = 'first offset' }   { shape_aspect =&gt;     chamfer_offset }     shape_aspect       shape_definition = shape_aspect         shape_definition characterized_definition = shape_definition characterized_definition &lt;-   property_definition.definition   property_definition &lt;-     property_definition.definition     property_definition_representation.definition     property_definition_representation   property_definition_representation.used_representation -&gt;     { representation =&gt;       shape_representation =&gt;         face_shape_representation }         representation       {representation.name = 'first face shape' }       representation.items[i] -&gt;         representation_item =&gt;           topological_representation_item =&gt;             face           </pre>

**Table 4 — Mapping table for manufacturing features UoF (continued)**

Application element	AIM element	Source	Rules	Reference path
second_face_shape	face	10303-42	3	chamfer <= transition_feature <= shape_aspect < shape_aspect.relationship.relatng_shape_aspect {shape_aspect_relationship => feature_component_relationship} shape_aspect_relationship shape_aspect.relationship.related_shape_aspect -> {shape_aspect.description = 'second offset' { shape_aspect => chamfer_offset } shape_aspect shape_definition = shape_aspect shape_definition characterized_definition = shape_definition characterized_definition <- property_definition.definition property_definition <- property_definition.definition property_definition_representation.definition property_definition_representation property_definition_representation.used_representation -> { representation => shape_representation => face_shape_representation } representation {representation.name = 'second face shape' representation.items[i] -> representation_item => topological_representation_item => face circular_closed_profile <= shape_aspect
CIRCULAR_CLOSED_PROFILE	circular_closed_profile	10303-522		

**Table 4 — Mapping table for manufacturing features UoF (continued)**

Application element	AIM element	Source	Rules	Reference path
diameter	length_measure_with_unit	10303-41		<pre> circular_closed_profile &lt;=   shape_aspect   shape_definition = shape_aspect   shape_definition characterized_definition = shape_definition characterized_definition &lt;-   property_definition.definition   property_definition &lt;-   property_definition_representation.definition { property_definition_representation =&gt;   shape_definition_representation } property_definition_representation property_definition_representation.used_representation -&gt;   {representation =&gt;   shape_representation =&gt;   shape_representation_with_parameters}   representation   representation.items[i] -&gt;   {representation_item.name = 'diameter'}   representation_item =&gt;   measure_representation_item &lt;=   measure_with_unit =&gt;   length_measure_with_unit </pre>

**Table 4 — Mapping table for manufacturing features UoF (continued)**

Application element	AIM element	Source	Rules	Reference path
CIRCULAR_CLOSED_SHAPE_PROFILE	outside_profile	10303-522		<pre> outside_profile &lt;= {feature_definition =&gt;   instantiated_feature} feature_definition &lt;=   characterized_object characterized_definition = characterized_object characterized_definition &lt;-   property_definition.definition property_definition =&gt;   product_definition_shape &lt;-   shape_aspect.of_shape   shape_aspect {shape_aspect.description = 'closed circular boundary occurrence'}</pre>
circular_closed_shape_profile to circular_closed_profile (as closed_boundary)	PATH			<pre> outside_profile &lt;= feature_definition &lt;=   characterized_object characterized_definition = characterized_object characterized_definition &lt;-   property_definition.definition property_definition =&gt;   product_definition_shape &lt;-   shape_aspect.of_shape   shape_aspect {shape_aspect.description = 'closed circular boundary occurrence'} shape_aspect &lt;-   shape_aspect.related_shape_aspect   {shape_aspect.relationship =&gt;   shape_defining_relationship} {shape_aspect.relationship.description = 'profile usage'} shape_aspect.relationship   shape_aspect.relationship.relatng_shape_aspect -&gt;   shape_aspect =&gt;   circular_closed_profile</pre>



**Table 4 — Mapping table for manufacturing features UoF (continued)**

Application element	AIM element	Source	Rules	Reference path
CIRCULAR_OFFSET	shape_aspect	10303-41		<pre> shape_aspect.related_shape_aspect   shape_aspect.relationship =&gt;     feature_component_relationship =&gt;       pattern_offset_membership]     [shape_aspect &lt;-       shape_aspect.related_shape_aspect         {shape_aspect.relationship =&gt;           feature_component_relationship}       shape_aspect.related_shape_aspect-&gt;         shape_aspect =&gt;           modified_pattern]                     </pre>
angular_offset	plane_angle_measure_with_unit	10303-41		<pre> shape_aspect   shape_definition = shape_aspect     shape_definition characterized_definition = shape_definition   characterized_definition &lt;-     property_definition.definition     property_definition &lt;-       property_definition_representation.definition     { property_definition_representation =&gt;       shape_definition_representation }   property_definition_representation   property_definition_representation.used_representation -&gt;     {representation =&gt;       shape_representation =&gt;         shape_representation_with_parameters}     representation     representation.items[i] -&gt;       {representation_item.name = 'offset' }       representation_item =&gt;         measure_representation_item &lt;=           measure_with_unit =&gt;             plane_angle_measure_with_unit                     </pre>

**Table 4 — Mapping table for manufacturing features UoF (continued)**

Application element	AIM element	Source	Rules	Reference path
index	count_measure	10303-41		<pre> shape_definition = shape_aspect shape_definition characterized_definition = shape_definition characterized_definition &lt;- property_definition.definition property_definition &lt;- property_definition_representation.definition { property_definition_representation =&gt; shape_definition_representation } property_definition_representation property_definition_representation.used_representation -&gt; {representation =&gt; shape_representation =&gt; shape_representation_with_parameters} representation representation.items[i] -&gt; {representation_item name = 'offset index?'} representation_item =&gt; measure_representation_item &lt;= measure_with_unit measure_with_unit.value_component -&gt; measure_value measure_value = count_measure count_measure                     </pre>

**Table 4 — Mapping table for manufacturing features UoF (continued)**

Application element	AIM element	Source	Rules	Reference path
CIRCULAR_OMIT	shape_aspect	10303-41		<pre> [shape_aspect &lt;- shape_aspect_relationship.related_shape_aspect shape_aspect_relationship =&gt; feature_component_relationship =&gt; pattern_omit_memberships] [shape_aspect &lt;- shape_aspect_relationship.related_shape_aspect {shape_aspect_relationship =&gt; feature_component_relationship} shape_aspect_relationship.relatng_shape_aspect-&gt; shape_aspect =&gt; modified_pattern]                     </pre>

**Table 4 — Mapping table for manufacturing features UoF (continued)**

Application element	AIM element	Source	Rules	Reference path
index	count_measure	10303-41		<pre> shape_definition = shape_aspect shape_definition characterized_definition = shape_definition characterized_definition &lt;- property_definition.definition property_definition &lt;- property_definition_representation.definition { property_definition_representation =&gt; shape_definition_representation } property_definition_representation property_definition_representation.used_representation -&gt; { representation =&gt; shape_representation =&gt; shape_representation_with_parameters} representation representation.items[i] -&gt; { representation_item.name = 'omit index' } representation_item =&gt; measure_representation_item &lt;= measure_with_unit measure_with_unit.value_component -&gt; measure_value measure_value = count_measure count_measure                     </pre>
CIRCULAR_PATH	path_feature_component	10303-522		<pre> path_feature_component &lt;= shape_aspect { (shape_aspect.description = 'partial circular') (shape_aspect.description = 'complete circular') }                     </pre>

**Table 4 — Mapping table for manufacturing features UoF (continued)**

Application element	AIM element	Source	Rules	Reference path
radius	length_measure_with_unit	10303-41		<pre> path_feature_component &lt;=   shape_aspect   shape_definition = shape_aspect   shape_definition characterized_definition = shape_definition characterized_definition &lt;-   property_definition.definition   property_definition &lt;-   property_definition_representation.definition { property_definition_representation =&gt;   shape_definition_representation } property_definition_representation property_definition_representation.used_representation -&gt;   {representation =&gt;   shape_representation =&gt;   shape_representation_with_parameters}   representation   representation.items[i] -&gt;   {representation_item.name = 'radius'}   representation_item =&gt;   measure_representation_item &lt;=   measure_with_unit =&gt;   length_measure_with_unit </pre>
CIRCULAR_PATTERN	circular_pattern	10303-522		<pre> circular_pattern &lt;=   replicate_feature &lt;=   {feature_definition =&gt;   instanced_feature}   feature_definition &lt;=   characterized_object </pre>

**Table 4 — Mapping table for manufacturing features UoF (continued)**

Application element	AIM element	Source	Rules	Reference path
angle_increment	plane_angle_measure_with_unit	10303-41		<pre> circular_pattern &lt;=   replicate_feature &lt;=     feature_definition &lt;=       characterized_object         characterized_definition = characterized_object           characterized_definition &lt;-             property_definition.definition               { property_definition =&gt;                 product_definition_shape }             property_definition &lt;-               property_definition_representation.definition                 { property_definition_representation =&gt;                   shape_definition_representation }               property_definition_representation                 { property_definition_representation.used_representation -&gt;                   {representation =&gt;                     shape_representation =&gt;                       shape_representation_with_parameters}                     representation                       representation.items[] -&gt;                         {representation_item.name = 'angular spacing'}                     representation_item =&gt;                       measure_representation_item &lt;=                         measure_with_unit =&gt;                           plane_angle_measure_with_unit                 </pre>

**Table 4 — Mapping table for manufacturing features UoF (continued)**

Application element	AIM element	Source	Rules	Reference path
number_of_feature	count_measure	10303-41		<pre> circular_pattern &lt;= replicate_feature &lt;= feature_definition &lt;= characterized_object characterized_definition = characterized_object characterized_definition &lt;- property_definition.definition { property_definition =&gt; product_definition_shape } property_definition &lt;- property_definition.definition { property_definition_representation =&gt; shape_definition_representation } property_definition_representation { property_definition_representation.used_representation -&gt; {representation =&gt; shape_representation =&gt; shape_representation_with_parameters} representation representation.items[i] -&gt; {representation_item.name = 'number of features' } representation_item =&gt; measure_representation_item &lt;= measure_with_unit measure_with_unit_value_component -&gt; measure_value measure_value = count_measure count_measure                     </pre>

**Table 4 — Mapping table for manufacturing features UoF (continued)**

Application element	AIM element	Source	Rules	Reference path
circular_pattern to circular_offset (as relocated_base_feature)	PATH			<pre> circular_pattern &lt;= replicate_feature &lt;= feature_definition &lt;= characterized_object characterized_definition = characterized_object characterized_definition &lt;- property_definition.definition property_definition =&gt; product_definition_shape &lt;- shape_aspect.of_shape shape_aspect &lt;- [shape_aspect_relationship.relatng_shape_aspect {shape_aspect_relationship =&gt; feature_component_membership =&gt; pattern_offset_membership} shape_aspect_relationship shape_aspect_relationship.related_shape_aspect -&gt; shape_aspect] [shape_aspect_relationship.related_shape_aspect {shape_aspect_relationship =&gt; feature_component_membership} shape_aspect_relationship.description = 'base pattern' } shape_aspect_relationship.relatng_shape_aspect-&gt; shape_aspect &lt;- {shape_aspect =&gt; modified_pattern} shape_aspect_relationship.relatng_shape_aspect {shape_aspect_relationship =&gt; feature_component_membership} {shape_aspect_relationship.description = 'modified pattern' } shape_aspect_relationship.related_shape_aspect-&gt; shape_aspect]                     </pre>



**Table 4 — Mapping table for manufacturing features UoF (continued)**

Application element	AIM element	Source	Rules	Reference path
circular_pattern to circular_omit (as missing_base_feature)	PATH			<pre> circular_pattern &lt;=   replicate_feature &lt;=   feature_definition &lt;=   characterized_object   characterized_definition = characterized_object   characterized_definition &lt;-   property_definition.definition   property_definition =&gt;   product_definition_shape &lt;-   shape_aspect.of_shape   shape_aspect &lt;-   [shape_aspect_relationship.relatng_shape_aspect   {shape_aspect_relationship =&gt;   feature_component_relationship =&gt;   pattern_omit_membership}   shape_aspect_relationship   shape_aspect_relationship.related_shape_aspect -&gt;   shape_aspect]   [ shape_aspect_relationship.related_shape_aspect   {shape_aspect_relationship =&gt;   feature_component_relationship}   {shape_aspect_relationship.description = 'base pattern'}   shape_aspect_relationship.relatng_shape_aspect-&gt;   shape_aspect &lt;-   {shape_aspect =&gt;   modified_pattern}   shape_aspect_relationship.relatng_shape_aspect   {shape_aspect_relationship =&gt;   feature_component_relationship}   {shape_aspect_relationship.description = 'modified pattern'}   shape_aspect_relationship.related_shape_aspect-&gt;   shape_aspect]                     </pre>

**Table 4 — Mapping table for manufacturing features UoF (continued)**

Application element	AIM element	Source	Rules	Reference path
base_feature_diameter	length_measure_with_unit	10303-41		<pre> circular_pattern &lt;= replicate_feature &lt;= feature_definition &lt;= characterized_object characterized_definition = characterized_object characterized_definition &lt;- property_definition.definition { property_definition =&gt; product_definition_shape } property_definition &lt;- property_definition_representation.definition { property_definition_representation =&gt; shape_definition_representation } property_definition_representation property_definition_representation.used_representation -&gt; {representation =&gt; shape_representation =&gt; shape_representation_with_parameters} representation representation.items[] -&gt; {representation_item.name = 'diameter'} representation_item =&gt; measure_representation_item &lt;= measure_with_unit =&gt; length_measure_with_unit                     </pre>

**Table 4 — Mapping table for manufacturing features UoF (continued)**

Application element	AIM element	Source	Rules	Reference path
base_feature_rotation	plane_angle_measure_with_unit	10303-41		<pre> circular_pattern &lt;= replicate_feature &lt;= feature_definition &lt;= characterized_object characterized_definition = characterized_object characterized_definition &lt;- property_definition.definition { property_definition =&gt; product_definition_shape } property_definition &lt;- property_definition.definition { property_definition_representation =&gt; shape_definition_representation } property_definition_representation { property_definition_representation =&gt; property_definition_representation.used_representation -&gt; {representation =&gt; shape_representation =&gt; shape_representation_with_parameters} representation representation.items[i] -&gt; {representation_item.name = 'base feature rotation'} representation_item =&gt; measure_representation_item &lt;= measure_with_unit =&gt; plane_angle_measure_with_unit                     </pre>
CLOSED_POCKET	pocket	10303-522		<pre> pocket &lt;= {feature_definition =&gt; instance_feature } feature_definition &lt;= characterized_object                     </pre>

**Table 4 — Mapping table for manufacturing features UoF (continued)**

Application element	AIM element	Source	Rules	Reference path
<p>closed_pocket to closed_profile (as feature_boundary)</p> <p>#1: preferred #2: alternate, compatible with AP 224 rectangular_closed_pocket usage</p> <p>See NOTE 9</p>	<p>PATH</p>			<pre> pocket &lt;= feature_definition &lt;= characterized_object #2: { characterized_object.description = 'closed rectangular' } characterized_definition = characterized_object characterized_definition &lt;- property_definition.definition property_definition =&gt; product_definition_shape &lt;- shape_aspect.of_shape #1: {shape_aspect.description = 'boundary occurrence'} #2: {shape_aspect.description = 'closed boundary occurrence'} shape_aspect &lt;- shape_aspect.related_shape_aspect {shape_aspect.relationship =&gt; shape_defining_relationship} {shape_aspect.relationship.description = 'profile usage'} shape_aspect.relationship shape_aspect.relationship.relatng_shape_aspect -&gt; #1: {shape_aspect.description = 'boundary'} shape_aspect =&gt; #1: (circular_closed_profile) #1: (closed_path_profile) #1: (ngon_closed_profile) #1,#2: (rectangular_closed_profile) </pre>
<p>CLOSED_PROFILE</p>	<p>(circular_closed_profile) (closed_path_profile) (ngon_closed_profile) (rectangular_closed_profile)</p>	<p>10303-522 10303-522 10303-522 10303-522</p>		<pre> (circular_closed_profile &lt;=) (closed_path_profile &lt;=) (ngon_closed_profile &lt;=) (rectangular_closed_profile &lt;=) shape_aspect </pre>
<p>COMPLETE_CIRCULAR_PATH</p>	<p>path_feature_component</p>	<p>10303-522</p>		<pre> path_feature_component &lt;= shape_aspect { shape_aspect.description = 'complete circular' } </pre>

**Table 4 — Mapping table for manufacturing features UoF (continued)**

Application element	AIM element	Source	Rules	Reference path
COMPOUND_FEATURE	compound_feature	10303-522		<pre> compound_feature &lt;= {feature_definition =&gt;   instantiated_feature} feature_definition &lt;=   characterized_object characterized_definition = characterized_object characterized_definition &lt;-   property_definition.definition property_definition =&gt;   product_definition_shape &lt;-   shape_aspect.of_shape   shape_aspect {shape_aspect.name = 'compound feature in solid' }</pre>
compound_feature to compound_feature_select (as elements) #1: as machining_feature #2: as transition_feature	PATH			<pre> compound_feature &lt;= feature_definition &lt;=   characterized_object characterized_definition = characterized_object characterized_definition &lt;-   property_definition.definition   property_definition =&gt;   product_definition_shape &lt;-   shape_aspect.of_shape   {shape_aspect =&gt;   composite_shape_aspect}   shape_aspect &lt;-   shape_aspect.relationship.relatng_shape_aspect   {shape_aspect_relationship=&gt;   feature_component_relationship}   shape_aspect_relationship.related_shape_aspect-&gt;   shape_aspect =&gt;   #1: (instantced_feature)   #2: (transition_feature)</pre>

**Table 4 — Mapping table for manufacturing features UoF (continued)**

Application element	AIM element	Source	Rules	Reference path
feature_description	characterized_object.description	10303-41		compound_feature <= feature_definition <= characterized_object characterized_object.description
feature_name	characterized_object.name	10303-41		compound_feature <= feature_definition <= characterized_object characterized_object.name
CONICAL_HOLE_BOTTOM	hole_bottom	10303-522		hole_bottom <= shape_aspect { shape_aspect.description = 'conical' }

**Table 4 — Mapping table for manufacturing features UoF (continued)**

Application element	AIM element	Source	Rules	Reference path
tip_angle	plane_angle_measure_with_unit	10303-41		<pre> hole_bottom &lt;=   shape_aspect   shape_definition = shape_aspect   shape_definition characterized_definition = shape_definition characterized_definition &lt;-   property_definition.definition   property_definition &lt;-   property_definition_representation.definition { property_definition_representation =&gt;   shape_definition_representation } property_definition_representation property_definition_representation.used_representation -&gt;   {representation =&gt;   shape_representation =&gt;   shape_representation_with_parameters}   representation   representation.items[i] -&gt;   {representation_item.name = 'tip_angle'}   representation_item =&gt;   measure_representation_item &lt;=   measure_with_unit =&gt;   plane_angle_measure_with_unit                     </pre>

**Table 4 — Mapping table for manufacturing features UoF (continued)**

Application element	AIM element	Source	Rules	Reference path
tip_radius	length_measure_with_unit	10303-41		<pre> hole_bottom &lt;=   shape_aspect   shape_definition = shape_aspect   shape_definition characterized_definition = shape_definition characterized_definition &lt;-   property_definition.definition   property_definition &lt;-   property_definition_representation.definition { property_definition_representation =&gt;   shape_definition_representation } property_definition_representation property_definition_representation.used_representation -&gt;   {representation =&gt;   shape_representation =&gt;   shape_representation_with_parameters}   representation   representation.items[j] -&gt;   {representation_item.name = 'tip radius'}   representation_item =&gt;   measure_representation_item &lt;=   measure_with_unit =&gt;   length_measure_with_unit                     </pre>



**Table 4 — Mapping table for manufacturing features UoF (continued)**

Application element	AIM element	Source	Rules	Reference path
COUNTERBORE_HOLE	composite_hole	10303-522		<pre> composite_hole &lt;= compound_feature &lt;= { feature_definition =&gt;   instantiated_feature } feature_definition &lt;= characterized_object { characterized_object.description = 'counterbore' } { characterized_definition = characterized_object   characterized_definition &lt;-   property_definition.definition   property_definition =&gt;   product_definition_shape &lt;-   shape_aspect.of_shape   { shape_aspect =&gt;   composite_shape_aspect }   shape_aspect &lt;-   shape_aspect_relationship.relatng_shape_aspect   { shape_aspect_relationship.name = 'large hole' }   shape_aspect_relationship=&gt;   feature_component_relationship } { characterized_definition = characterized_object   characterized_definition &lt;-   property_definition.definition   property_definition =&gt;   product_definition_shape &lt;-   shape_aspect.of_shape   { shape_aspect =&gt;   composite_shape_aspect }   shape_aspect &lt;-   shape_aspect_relationship.relatng_shape_aspect   { shape_aspect_relationship.name = 'small hole' }   shape_aspect_relationship=&gt;   feature_component_relationship } </pre>

**Table 4 — Mapping table for manufacturing features UoF (continued)**

Application element	AIM element	Source	Rules	Reference path
COUNTERSUNK_HOLE	composite_hole	10303-522		<pre> composite_hole &lt;= compound_feature &lt;= { feature_definition =&gt;   instantiated_feature } feature_definition &lt;= characterized_object { characterized_object.description = 'countersunk' } { characterized_definition = characterized_object   characterized_definition &lt;-   property_definition.definition   property_definition =&gt;   product_definition_shape &lt;-   shape_aspect.of_shape   { shape_aspect =&gt;   composite_shape_aspect }   shape_aspect &lt;-   shape_aspect.relationship.relatng_shape_aspect { shape_aspect_relationship.name = 'tapered hole' }   shape_aspect_relationship=&gt;   feature_component_relationship } { characterized_definition = characterized_object   characterized_definition &lt;-   property_definition.definition   property_definition =&gt;   product_definition_shape &lt;-   shape_aspect.of_shape   { shape_aspect =&gt;   composite_shape_aspect }   shape_aspect &lt;-   shape_aspect.relationship.relatng_shape_aspect { shape_aspect_relationship.name = 'constant diameter hole' }   shape_aspect_relationship=&gt;   feature_component_relationship } </pre>

**Table 4 — Mapping table for manufacturing features UoF (continued)**

Application element	AIM element	Source	Rules	Reference path
DEFINED_THREAD	thread	10303-522		<pre> thread &lt;= {feature_definition =&gt;   instantiated_feature} feature_definition &lt;= characterized_object                     </pre>
pitch_diameter	length_measure_with_unit	10303-41		<pre> thread &lt;= feature_definition &lt;= characterized_object characterized_definition &lt;= characterized_definition &lt;- property_definition.definition {property_definition =&gt;   product_definition_shape } property_definition &lt;- property_definition.definition {property_definition_representation.definition   property_definition_representation =&gt;   shape_definition_representation } property_definition_representation property_definition_representation.used_representation -&gt; {representation =&gt;   shape_representation =&gt;   shape_representation_with_parameters} representation representation.items[] -&gt; {representation_item.name = 'pitch diameter'} representation_item =&gt; measure_representation_item &lt;= measure_with_unit =&gt; length_measure_with_unit                     </pre>

**Table 4 — Mapping table for manufacturing features UoF (continued)**

Application element	AIM element	Source	Rules	Reference path
minor_diameter	length_measure_with_unit	10303-41		<pre> thread &lt;= feature_definition &lt;= characterized_object characterized_definition = characterized_object characterized_definition &lt;- property_definition.definition { property_definition =&gt; product_definition_shape } property_definition &lt;- property_definition_representation.definition { property_definition_representation =&gt; shape_definition_representation } property_definition_representation property_definition_representation.used_representation -&gt; {representation =&gt; shape_representation =&gt; shape_representation_with_parameters} representation representation.items[i] -&gt; {representation_item.name = 'minor diameter'} representation_item =&gt; measure_representation_item &lt;= measure_with_unit =&gt; length_measure_with_unit                     </pre>

**Table 4 — Mapping table for manufacturing features UoF (continued)**

Application element	AIM element	Source	Rules	Reference path
crest	length_measure_with_unit	10303-41		<pre> thread &lt;= feature_definition &lt;= characterized_object characterized_definition = characterized_object characterized_definition &lt;- property_definition.definition { property_definition =&gt; product_definition_shape } property_definition &lt;- property_definition.definition { property_definition_representation =&gt; shape_definition_representation } property_definition_representation property_definition_representation.used_representation -&gt; {representation =&gt; shape_representation =&gt; shape_representation_with_parameters} representation representation.items[i] -&gt; {representation_item.name = 'crest' } representation_item =&gt; measure_representation_item &lt;= measure_with_unit =&gt; length_measure_with_unit                     </pre>
DIAMETER_TAPER	taper	10303-522		<pre> taper &lt;= shape_aspect shape_aspect.description = 'diameter taper' } { shape_aspect.description = 'diameter taper'-&gt; product_definition_shape &lt;= property_definition property_definition.definition-&gt; characterized_definition characterized_definition = characterized_object feature_component_definition }                     </pre>

**Table 4 — Mapping table for manufacturing features UoF (continued)**

Application element	AIM element	Source	Rules	Reference path
final_diameter	length_measure_with_unit	10303-41		<pre> taper &lt;=   shape_aspect   shape_definition = shape_aspect   shape_definition   characterized_definition = shape_definition   characterized_definition &lt;-   property_definition.definition   property_definition &lt;-   property_definition_representation.definition   { property_definition_representation =&gt;   shape_definition_representation }   property_definition_representation   property_definition_representation.used_representation -&gt;   {representation =&gt;   shape_representation =&gt;   shape_representation_with_parameters}   representation   representation.items[j] -&gt;   {representation_item.name = 'final diameter'}   representation_item =&gt;   measure_representation_item &lt;=   measure_with_unit =&gt;   length_measure_with_unit </pre>
EDGE_ROUND	edge_round	10303-522		<pre> edge_round &lt;=   transition_feature &lt;=   shape_aspect   {shape_aspect.description = 'constant radius'} </pre>

**Table 4 — Mapping table for manufacturing features UoF (continued)**

Application element	AIM element	Source	Rules	Reference path
radius	length_measure_with_unit	10303-41		<pre> edge_round &lt;= transition_feature &lt;= shape_aspect shape_definition = shape_aspect shape_definition characterized_definition = shape_definition characterized_definition &lt;- property_definition.definition property_definition &lt;- property_definition_representation.definition { property_definition_representation =&gt; shape_definition_representation } property_definition_representation property_definition_representation.used_representation -&gt; {representation =&gt; shape_representation =&gt; shape_representation_with_parameters} representation representation.items[i] -&gt; {representation_item.name = 'radius' } representation_item =&gt; measure_representation_item &lt;= measure_with_unit =&gt; length_measure_with_unit                     </pre>

**Table 4 — Mapping table for manufacturing features UoF (continued)**

Application element	AIM element	Source	Rules	Reference path
first_offset_amount	length_measure_with_unit	10303-41		<pre> edge_round &lt;= transition_feature &lt;= shape_aspect shape_definition = shape_aspect shape_definition characterized_definition = shape_definition characterized_definition &lt;- property_definition.definition property_definition &lt;- property_definition_representation.definition { property_definition_representation =&gt; shape_definition_representation } property_definition_representation property_definition_representation.used_representation -&gt; {representation =&gt; shape_representation =&gt; shape_representation_with_parameters} representation representation.items[i] -&gt; {representation_item.name = 'first offset'} representation_item =&gt; measure_representation_item &lt;= measure_with_unit =&gt; length_measure_with_unit                     </pre>



**Table 4 — Mapping table for manufacturing features UoF (continued)**

Application element	AIM element	Source	Rules	Reference path
second_offset_amount	length_measure_with_unit	10303-41		<pre> edge_round &lt;= transition_feature &lt;= shape_aspect shape_definition = shape_aspect shape_definition characterized_definition = shape_definition characterized_definition &lt;- property_definition.definition property_definition &lt;- property_definition_representation.definition { property_definition_representation =&gt; shape_definition_representation } property_definition_representation property_definition_representation.used_representation -&gt; {representation =&gt; shape_representation =&gt; shape_representation_with_parameters} representation representation.items[i] -&gt; {representation_item.name = 'second offset'} representation_item =&gt; measure_representation_item &lt;= measure_with_unit =&gt; length_measure_with_unit                     </pre>

**Table 4 — Mapping table for manufacturing features UoF (continued)**

Application element	AIM element	Source	Rules	Reference path
edge_round_face	face	10303-42	7	<pre> edge_round &lt;= transition_feature &lt;= shape_aspect shape_definition = shape_aspect shape_definition characterized_definition = shape_definition characterized_definition &lt;- property_definition.definition property_definition &lt;- property_definition_representation.definition { property_definition_representation =&gt; shape_definition_representation } property_definition_representation property_definition_representation.used_representation -&gt; { representation =&gt; shape_representation=&gt; face_shape_representation } representation { representation.name = 'edge round face' } representation.items[i] -&gt; representation_item =&gt; topological_representation_item =&gt; face                     </pre>

**Table 4 — Mapping table for manufacturing features UoF (continued)**

Application element	AIM element	Source	Rules	Reference path
first_face_shape	face	10303-42	7	<pre> edge_round &lt;= transition_feature &lt;= shape_aspect shape_definition = shape_aspect shape_definition characterized_definition = shape_definition characterized_definition &lt;- property_definition.definition property_definition &lt;- property_definition_representation.definition property_definition_representation property_definition_representation.used_representation -&gt; { representation =&gt; shape_representation=&gt; face_shape_representation } representation.name = 'first face shape' } representation.items[i] -&gt; representation_item =&gt; topological_representation_item =&gt; face                     </pre>

**Table 4 — Mapping table for manufacturing features UoF (continued)**

Application element	AIM element	Source	Rules	Reference path
second_face_shape	face	10303-42	7	<pre> edge_round &lt;= transition_feature &lt;= shape_aspect shape_definition = shape_aspect shape_definition characterized_definition = shape_definition characterized_definition &lt;- property_definition.definition property_definition &lt;- property_definition_representation.definition property_definition_representation property_definition_representation.used_representation -&gt; { representation =&gt; shape_representation=&gt; face_shape_representation } representation { representation.name = 'second face shape' } representation.items[i] -&gt; representation_item =&gt; topological_representation_item =&gt; face                     </pre>
FLAT_HOLE_BOTTOM	hole_bottom	10303-522		<pre> hole_bottom &lt;= shape_aspect { shape_aspect.description = 'flat' }                     </pre>
FLAT_SLOT_END_TYPE	slot_end	10303-522		<pre> slot_end &lt;= shape_aspect { shape_aspect.description = 'flat' }                     </pre>

**Table 4 — Mapping table for manufacturing features UoF (continued)**

Application element	AIM element	Source	Rules	Reference path
corner_radius1	length_measure_with_unit	10303-41		<pre> slot_end &lt;= shape_aspect shape_definition = shape_aspect shape_definition characterized_definition = shape_definition characterized_definition &lt;- property_definition.definition property_definition &lt;- property_definition_representation.definition { property_definition_representation =&gt; shape_definition_representation } property_definition_representation property_definition_representation.used_representation -&gt; {representation =&gt; shape_representation_with_parameters} representation representation.items[i] -&gt; {representation_item.name = 'first radius' } representation_item =&gt; measure_representation_item &lt;= measure_with_unit =&gt; length_measure_with_unit                     </pre>

**Table 4 — Mapping table for manufacturing features UoF (continued)**

Application element	AIM element	Source	Rules	Reference path
corner_radius2	length_measure_with_unit	10303-41		<pre> slot_end &lt;= shape_aspect shape_definition = shape_aspect shape_definition characterized_definition = shape_definition characterized_definition &lt;- property_definition.definition property_definition &lt;- property_definition_representation.definition { property_definition_representation =&gt; shape_definition_representation } property_definition_representation property_definition_representation.used_representation -&gt; {representation =&gt; shape_representation_with_parameters} representation representation.items[i] -&gt; {representation_item.name = 'second radius'} representation_item =&gt; measure_representation_item &lt;= measure_with_unit =&gt; length_measure_with_unit </pre>
FLAT_WITH_RADIUS_HOLE_BOTTOM	hole_bottom	10303-522		<pre> hole_bottom &lt;= shape_aspect { shape_aspect.description = 'flat with radius' } </pre>

**Table 4 — Mapping table for manufacturing features UoF (continued)**

Application element	AIM element	Source	Rules	Reference path
corner_radius	length_measure_with_unit	10303-41		hole_bottom <= shape_aspect shape_definition = shape_aspect shape_definition characterized_definition = shape_definition characterized_definition <= property_definition.definition property_definition <= property_definition_representation.definition { property_definition_representation => shape_definition_representation } property_definition_representation property_definition_representation.used_representation -> {representation => shape_representation => shape_representation_with_parameters} representation representation.items[i] -> {representation_item.name = 'corner radius'} representation_item => measure_representation_item <= measure_with_unit => length_measure_with_unit
GENERAL_CLOSED_PROFILE	closed_path_profile	10303-522		closed_path_profile <= shape_aspect

**Table 4 — Mapping table for manufacturing features UoF (continued)**

Application element	AIM element	Source	Rules	Reference path
<p>closed_profile_shape                      #1: if a bounded_curve                      #2: if an edge_curve                      #3: if a path</p>	<p>#1: (bounded_curve)                      #2: (edge_curve)                      #3: (path)</p>	<p>10303-42                      10303-42                      10303-42</p>		<pre> closed_path_profile &lt;=   shape_aspect   shape_definition = shape_aspect   shape_definition   characterized_definition = shape_definition   characterized_definition &lt;-   property_definition.definition   property_definition &lt;-   property_definition_representation.definition   property_definition_representation   property_definition_representation.used_representation -&gt;   { representation =&gt;     shape_representation=&gt;     path_shape_representation }   representation   representation.items[i] -&gt;   representation_item =&gt;   #1: (geometric_representation_item =&gt;     curve =&gt;     bounded_curve)   #2: (geometric_representation_item =&gt;     edge_curve)   #3: (topological_representation_item =&gt;     path)                     </pre>



**Table 4 — Mapping table for manufacturing features UoF (continued)**

Application element	AIM element	Source	Rules	Reference path
GENERAL_OUTSIDE_PROFILE	outside_profile	10303-522		<pre> outside_profile &lt;= {   feature_definition =&gt;   {     instanced_feature }   feature_definition &lt;=   characterized_object   characterized_definition = characterized_object   characterized_definition &lt;-   property_definition.definition   property_definition =&gt;   product_definition_shape &lt;-   shape_aspect.of_shape   shape_aspect } shape_aspect.description = 'outside boundary' </pre>

**Table 4 — Mapping table for manufacturing features UoF (continued)**

Application element	AIM element	Source	Rules	Reference path
general_outside_profile to profile (as feature_boundary)	PATH			<pre> outside_profile &lt;= feature_definition &lt;= characterized_object characterized_definition = characterized_object characterized_definition &lt;- property_definition.definition property_definition =&gt; product_definition_shape &lt;- shape_aspect.of_shape {shape_aspect.description = 'boundary occurrence'} shape_aspect &lt;- shape_aspect_relationship.related_shape_aspect {shape_aspect_relationship =&gt; shape_defining_relationship} {shape_aspect_relationship.description = 'profile usage'} shape_aspect_relationship shape_aspect_relationship.relatng_shape_aspect -&gt; {shape_aspect.description = 'outside boundary'} shape_aspect =&gt; (circular_closed_profile) (closed_path_profile) (ngon_closed_profile) (rectangular_closed_profile) (linear_profile) (open_path_profile) (partial_circular_profile) (rounded_u_profile) (square_u_profile) (tee_profile) (vee_profile) </pre>
GENERAL_PATH	path_feature_component	10303-522		<pre> path_feature_component &lt;= shape_aspect { shape_aspect.description = 'complex' } </pre>

**Table 4 — Mapping table for manufacturing features UoF (continued)**

Application element	AIM element	Source	Rules	Reference path
swept_path #1: if a bounded_curve #2: if an edge_curve #3: if a path	#1: (bounded_curve) #2: (edge_curve) #3: (path)	10303-42 10303-42 10303-42		<pre> shape_aspect shape_definition = shape_aspect shape_definition characterized_definition = shape_definition characterized_definition &lt;= property_definition.definition property_definition &lt;= property_definition.definition property_definition.definition property_definition_representation property_definition_representation property_definition_representation.used_representation -&gt; {representation.name = 'sweep path'} { representation =&gt; shape_representation=&gt; path_shape_representation } representation representation.items[i] -&gt; representation_item =&gt; #1: (geometric_representation_item =&gt; curve =&gt; bounded_curve) #2: (geometric_representation_item =&gt; edge_curve) #3: (topological_representation_item =&gt; path)                     </pre>
GENERAL_PATTERN	feature_pattern	10303-522		<pre> feature_pattern &lt;= replicate_feature &lt;= {feature_definition =&gt; instance_feature} feature_definition &lt;= characterized_object                     </pre>

**Table 4 — Mapping table for manufacturing features UoF (continued)**

Application element	AIM element	Source	Rules	Reference path
replicate_locations	axis2_placement_3d	10303-42		<pre> feature_pattern &lt;=   replicate_feature &lt;=     feature_definition &lt;=       characterized_object         characterized_definition = characterized_object           characterized_definition &lt;-             property_definition.definition               { property_definition =&gt;                 product_definition_shape }             property_definition &lt;-               property_definition_representation.definition                 { property_definition_representation =&gt;                   shape_definition_representation }             property_definition_representation               property_definition_representation.used_representation -&gt;                 {representation =&gt;                   shape_representation =&gt;                     shape_representation_with_parameters}                     representation                       representation.items[i] -&gt;                         {representation_item.name = 'base feature placement'}                           representation_item =&gt;                             geometric_representation_item =&gt;                               placement =&gt;                                 axis2_placement_3d </pre>
GENERAL_POCKET_BOTTOM_CONDITION	pocket_bottom	10303-522		<pre> pocket_bottom &lt;=   shape_aspect     { shape_aspect.description = 'complex' } </pre>

**Table 4 — Mapping table for manufacturing features UoF (continued)**

Application element	AIM element	Source	Rules	Reference path
general_pocket_bottom_condition to region (as shape)	PATH			<pre>                     pocket_bottom &lt;=                     shape_aspect                     shape_definition = shape_aspect                     shape_definition                     characterized_definition = shape_definition                     characterized_definition &lt;-                     property_definition.definition                     property_definition &lt;-                     property_definition_representation.definition                     property_definition_representation                     property_definition_representation.used_representation -&gt;                     {representation.name = 'floor face'}                     representation =&gt;                     shape_representation=&gt;                     face_shape_representation                     </pre>
GENERAL_PROFILE	open_path_profile	10303-522		See NOTE 11  open_path_profile <=                     shape_aspect

**Table 4 — Mapping table for manufacturing features UoF (continued)**

Application element	AIM element	Source	Rules	Reference path
its_profile #1: if a bounded_curve #2: if an edge_curve #3: if a path	#1: (bounded_curve) #2: (edge_curve) #3: (path)	10303-42 10303-42 10303-42		<pre> open_path_profile &lt;=   shape_aspect   shape_definition = shape_aspect   shape_definition   characterized_definition = shape_definition   characterized_definition &lt;-   property_definition.definition   property_definition &lt;-   property_definition_representation.definition   property_definition_representation   property_definition_representation.used_representation -&gt;   { representation =&gt;     shape_representation=&gt;     path_shape_representation }   representation   representation.items[i] -&gt;   representation_item =&gt;   #1: (geometric_representation_item =&gt;     curve =&gt;     bounded_curve)   #2: (geometric_representation_item =&gt;     edge_curve)   #3: (topological_representation_item =&gt;     path)                     </pre>
GENERAL_PROFILE_FLOOR	profile_floor	10303-522		<pre> profile_floor &lt;=   shape_aspect   { shape_aspect.description = 'complex' }                     </pre>

**Table 4 — Mapping table for manufacturing features UoF (continued)**

Application element	AIM element	Source	Rules	Reference path
floor	face	10303-42		<pre> profile_floor &lt;=   shape_aspect   shape_definition = shape_aspect   shape_definition characterized_definition = shape_definition characterized_definition &lt;-   property_definition.definition   property_definition &lt;-   property_definition_representation.definition   property_definition_representation property_definition_representation.used_representation -&gt;   { representation =&gt;     shape_representation=&gt;     face_shape_representation }   representation.name = 'floor' }   representation.items[i] -&gt;   representation_item =&gt;   topological_representation_item =&gt;     face                     </pre>
GENERAL_SHAPE_PROFILE	outside_profile	10303-522		<pre> outside_profile &lt;=   {feature_definition =&gt;     instanced_feature}   feature_definition &lt;=     characterized_object   characterized_definition = characterized_object   characterized_definition &lt;-   property_definition.definition   property_definition =&gt;   product_definition_shape &lt;-   shape_aspect.of_shape   shape_aspect   {shape_aspect.description = 'complex boundary occurrence'}                     </pre>

**Table 4 — Mapping table for manufacturing features UoF (continued)**

Application element	AIM element	Source	Rules	Reference path
general_shape_profile to profile (as profile_boundary)	PATH			<pre> outside_profile &lt;= feature_definition &lt;= characterized_object characterized_definition = characterized_object characterized_definition &lt;- property_definition.definition property_definition =&gt; product_definition_shape &lt;- shape_aspect.of_shape {shape_aspect.description = 'complex boundary occurrence'} shape_aspect &lt;- shape_aspect.related_shape_aspect {shape_aspect.relationship =&gt; shape_defining_relationship } { shape_aspect.relationship.description = 'profile usage' } shape_aspect.relationship shape_aspect.relationship.relatng_shape_aspect -&gt; {shape_aspect.description = 'boundary'} shape_aspect =&gt; (circular_closed_profile) (closed_path_profile) (ngon_closed_profile) (rectangular_closed_profile) (open_path_profile) (partial_circular_profile) (rounded_u_profile) (square_u_profile) (tee_profile) (vee_profile) hole_bottom &lt;= shape_aspect </pre>
HOLE_BOTTOM_CONDITION	hole_bottom	10303-522		
LINEAR_PATH	path_feature_component	10303-522		<pre> path_feature_component &lt;= shape_aspect { shape_aspect.description = 'linear' } </pre>



**Table 4 — Mapping table for manufacturing features UoF (continued)**

Application element	AIM element	Source	Rules	Reference path
distance	length_measure_with_unit	10303-41		<pre> path_feature_component &lt;=   shape_aspect   shape_definition = shape_aspect   shape_definition characterized_definition = shape_definition characterized_definition &lt;-   property_definition.definition   property_definition &lt;-   property_definition_representation.definition { property_definition_representation =&gt;   shape_definition_representation } property_definition_representation property_definition_representation.used_representation -&gt;   {representation =&gt;   shape_representation =&gt;   shape_representation_with_parameters}   representation   representation.items[i] -&gt;   {representation_item.name = 'distance'}   representation_item =&gt;   measure_representation_item &lt;=   measure_with_unit =&gt;   length_measure_with_unit                     </pre>

**Table 4 — Mapping table for manufacturing features UoF (continued)**

Application element	AIM element	Source	Rules	Reference path
its_direction	direction	10303-42		path_feature_component <= shape_aspect shape_definition = shape_aspect shape_definition characterized_definition = shape_definition characterized_definition <= property_definition.definition property_definition <= property_definition_representation.definition property_definition_representation property_definition_representation.used_representation -> representation { representation => shape_representation=> direction_shape_representation } representation.items[i] -> representation_item => geometric_representation_item => direction
LINEAR_PROFILE	linear_profile	10303-522		linear_profile <= shape_aspect

**Table 4 — Mapping table for manufacturing features UoF (continued)**

Application element	AIM element	Source	Rules	Reference path
profile_length	length_measure_with_unit	10303-41		<pre> linear_profile &lt;=   shape_aspect   shape_definition = shape_aspect   shape_definition characterized_definition = shape_definition characterized_definition &lt;-   property_definition.definition   property_definition &lt;-   property_definition_representation.definition   { property_definition_representation =&gt;   shape_definition_representation } property_definition_representation property_definition_representation.used_representation -&gt;   {representation =&gt;   shape_representation =&gt;   shape_representation_with_parameters}   representation   representation.items[j] -&gt;   representation_item.name = 'profile length' }   representation_item =&gt;   measure_representation_item &lt;=   measure_with_unit =&gt;   length_measure_with_unit </pre>
LOOP_SLOT_END_TYPE	slot_end	10303-522		<pre> slot_end &lt;=   shape_aspect   { shape_aspect.description = 'loop' } </pre>
MACHINED_SURFACE	property_definition	10303-41		<pre> property_definition property_definition.name { (property_definition.name = 'bottom surface condition') (property_definition.name = 'bottom and side surface condition') (property_definition.name = 'side surface condition') } </pre>

**Table 4 — Mapping table for manufacturing features UoF (continued)**

Application element	AIM element	Source	Rules	Reference path
machined_surface to machining_feature (as its_machining_feature)	PATH			<pre> property_definition property_definition.definition -&gt; characterized_definition characterized_definition = shape_definition shape_definition shape_definition = shape_aspect shape_aspect =&gt; instanced_feature                     </pre>
surface_element	property_definition.name	10303-41		<pre> property_definition property_definition.name { (property_definition.name = 'bottom surface condition') (property_definition.name = 'bottom and side surface condition') (property_definition.name = 'side surface condition') }                     </pre>
MACHINING_FEATURE	instanced_feature	10303-522		<pre> instanced_feature &lt;= [shape_aspect] [feature_definition &lt;= characterized_object]                     </pre>

**Table 4 — Mapping table for manufacturing features UoF (continued)**

Application element	AIM element	Source	Rules	Reference path
<p>depth</p> <p>NOTE This is an optional attribute. See 5.2.1.2.1.1 and 4.2.194 for the procedure to determine the depth of features.</p>	<p>elementary_surface</p>	<p>10303-42</p>		<pre> instantiated_feature &lt;=   shape_aspect   shape_definition = shape_aspect   shape_definition characterized_definition = shape_definition characterized_definition &lt;-   property_definition.definition   { property_definition =&gt;   product_definition_shape }   property_definition &lt;-   property_definition_representation.definition   { property_definition_representation =&gt;   shape_definition_representation }   property_definition_representation   property_definition_representation.used_representation-&gt;   { representation =&gt;   shape_representation }   {representation.name = 'maximum feature limit' }   representation   representation.items[i] -&gt;   representation_item =&gt;   elementary_surface </pre>
<p>NGON_PROFILE</p>	<p>ngon_closed_profile</p>	<p>10303-522</p>		<pre> ngon_closed_profile &lt;=   shape_aspect </pre>

**Table 4 — Mapping table for manufacturing features UoF (continued)**

Application element	AIM element	Source	Rules	Reference path
diameter	length_measure_with_unit	10303-41		<pre> ngon_closed_profile &lt;=   shape_aspect   shape_definition = shape_aspect   shape_definition characterized_definition = shape_definition characterized_definition &lt;-   property_definition.definition   property_definition &lt;-   property_definition_representation.definition   { property_definition_representation =&gt;   shape_definition_representation }   property_definition_representation property_definition_representation.used_representation -&gt;   {representation =&gt;   shape_representation =&gt;   shape_representation_with_parameters}   representation   representation.items[i] -&gt;   { (representation_item.name = 'circumscribed diameter')   (representation_item.name = 'diameter across flats') }   representation_item =&gt;   measure_representation_item &lt;=   measure_with_unit =&gt;   length_measure_with_unit                     </pre>

**Table 4 — Mapping table for manufacturing features UoF (continued)**

Application element	AIM element	Source	Rules	Reference path
number_of_sides	count_measure	10303-41		<pre> ngon_closed_profile &lt;=   shape_aspect   shape_definition = shape_aspect   shape_definition characterized_definition = shape_definition characterized_definition &lt;-   property_definition.definition   property_definition &lt;-   property_definition_representation.definition   { property_definition_representation =&gt;   shape_definition_representation }   property_definition_representation property_definition_representation.used_representation -&gt;   {representation =&gt;   shape_representation =&gt;   shape_representation_with_parameters}   representation   representation.items[j] -&gt;   {representation_item.name = 'number of sides'}   representation_item =&gt;   measure_representation_item &lt;=   measure_with_unit   measure_with_unit.value_component -&gt;   measure_value   measure_value = count_measure   count_measure </pre>

**Table 4 — Mapping table for manufacturing features UoF (continued)**

Application element	AIM element	Source	Rules	Reference path
circumscribed_or_across_flats	(representation_item.name = 'circumscribed diameter') (representation_item.name = 'diameter across flats')	10303-41 10303-41		<pre> ngon_closed_profile &lt;=   shape_aspect   shape_definition = shape_aspect   shape_definition characterized_definition = shape_definition characterized_definition &lt;-   property_definition.definition   property_definition &lt;-   property_definition_representation.definition   { property_definition_representation =&gt;   shape_definition_representation }   property_definition_representation property_definition_representation.used_representation -&gt;   {representation =&gt;   shape_representation =&gt;   shape_representation_with_parameters}   representation   representation.items[i] -&gt;   representation_item   { (representation_item.name = 'circumscribed diameter')   (representation_item.name = 'diameter across flats') }</pre>
OPEN_POCKET	pocket	10303-522		<pre> pocket &lt;=   {feature_definition =&gt;   instantiated_feature}   feature_definition &lt;=   characterized_object</pre>



**Table 4 — Mapping table for manufacturing features UoF (continued)**

Application element	AIM element	Source	Rules	Reference path
<p>open_pocket to open_profile (as open_boundary)</p> <p>#1: preferred</p> <p>#2: alternate, compatible with AP 224 rectangular_open_pocket usage</p> <p>See NOTE 9</p>	<p>PATH</p>			<pre> pocket &lt;= feature_definition &lt;= characterized_object #2: { characterized_object.description = 'open rectangular' } characterized_definition = characterized_object characterized_definition &lt;- property_definition.definition property_definition =&gt; product_definition_shape &lt;- shape_aspect.of_shape #1: {shape_aspect.description = 'boundary occurrence'} #2: {shape_aspect.description = 'open boundary occurrence'} shape_aspect &lt;- shape_aspect.related_shape_aspect {shape_aspect.relationship =&gt; shape_defining_relationship} {shape_aspect.relationship.description = 'profile usage'} shape_aspect.relationship shape_aspect.relationship.relatng_shape_aspect -&gt; #1: {shape_aspect.description = 'boundary'} } shape_aspect =&gt; #1: (open_path_profile) #1: (partial_circular_profile) #1: (rounded_u_profile) #1, #2: (square_u_profile) #1: (tee_profile) #1: (vee_profile) </pre>

**Table 4 — Mapping table for manufacturing features UoF (continued)**

Application element	AIM element	Source	Rules	Reference path
open_pocket to open_profile (as wall_boundary)	PATH			<pre> pocket &lt;= feature_definition &lt;= characterized_object characterized_definition = characterized_object characterized_definition &lt;- property_definition.definition property_definition =&gt; product_definition_shape &lt;- shape_aspect.of_shape {shape_aspect.description = 'wall boundary occurrence'} shape_aspect &lt;- shape_aspect.relationship.related_shape_aspect {shape_aspect.relationship =&gt; shape_defining_relationship} shape_aspect.relationship.description = 'wall boundary usage'} shape_aspect.relationship.relatng_shape_aspect -&gt; {shape_aspect.description = 'wall boundary'} shape_aspect =&gt; (open_path_profile) (partial_circular_profile) (rounded_u_profile) (square_u_profile) (tee_profile) (vee_profile) </pre>
OPEN_PROFILE	<pre> (linear_profile) (open_path_profile) (partial_circular_profile) (rounded_u_profile) (square_u_profile) (tee_profile) (vee_profile) </pre>	<p>10303-522 10303-522 10303-522 10303-522 10303-522 10303-522</p>		<pre> (linear_profile &lt;=) (open_path_profile &lt;=) (partial_circular_profile &lt;=) (rounded_u_profile &lt;=) (square_u_profile &lt;=) (tee_profile &lt;=) (vee_profile &lt;=) shape_aspect </pre>

**Table 4 — Mapping table for manufacturing features UoF (continued)**

Application element	AIM element	Source	Rules	Reference path
OPEN_SLOT_END_TYPE	slot_end	10303-522		<pre> slot_end &lt;= shape_aspect { shape_aspect.description = 'open' }                     </pre>
PARTIAL_AREA_DEFINITION	applied_area	10303-522		<pre> applied_area &lt;= shape_aspect { shape_aspect shape_aspect.of_shape-&gt; product_definition_shape }                     </pre>
effective_length	length_measure_with_unit	10303-41		<pre> applied_area &lt;= shape_aspect shape_definition = shape_aspect shape_definition characterized_definition = shape_definition characterized_definition &lt;- property_definition.definition property_definition &lt;- property_definition_representation.definition { property_definition_representation =&gt; shape_definition_representation } property_definition_representation property_definition_representation.used_representation -&gt; { representation =&gt; shape_representation =&gt; shape_representation_with_parameters } representation representation.items[i] -&gt; { representation_item.name = 'effective length' } representation_item =&gt; measure_with_unit &lt;= length_measure_with_unit                     </pre>

**Table 4 — Mapping table for manufacturing features UoF (continued)**

Application element	AIM element	Source	Rules	Reference path
placement	axis2_placement_3d	10303-42		<pre> applied_area &lt;=   shape_aspect   shape_definition = shape_aspect   shape_definition characterized_definition = shape_definition characterized_definition &lt;-   property_definition.definition   property_definition &lt;-   property_definition_representation.definition { property_definition_representation =&gt;   shape_definition_representation } property_definition_representation property_definition_representation.used_representation -&gt;   {representation =&gt;   shape_representation =&gt;   shape_representation_with_parameters}   representation   representation.items[i] -&gt;   {representation_item.name = 'orientation'}   representation_item =&gt;   geometric_representation_item =&gt;   placement =&gt;   axis2_placement_3d                     </pre>

**Table 4 — Mapping table for manufacturing features UoF (continued)**

Application element	AIM element	Source	Rules	Reference path
maximum_length	length_measure_with_unit	10303-41		<pre> applied_area &lt;=   shape_aspect   shape_definition = shape_aspect   shape_definition characterized_definition = shape_definition characterized_definition &lt;-   property_definition.definition   property_definition &lt;-   property_definition_representation.definition { property_definition_representation =&gt;   shape_definition_representation } property_definition_representation property_definition_representation.used_representation -&gt;   {representation =&gt;   shape_representation =&gt;   shape_representation_with_parameters} representation representation.items[i] -&gt;   {representation_item.name = 'maximum length'}   representation_item =&gt;   measure_representation_item &lt;=   measure_with_unit =&gt;   length_measure_with_unit </pre>
PARTIAL_CIRCULAR_PATH	path_feature_component	10303-522		<pre> path_feature_component &lt;=   shape_aspect { shape_aspect.description = 'partial circular' } </pre>

**Table 4 — Mapping table for manufacturing features UoF (continued)**

Application element	AIM element	Source	Rules	Reference path
sweep_angle	plane_angle_measure_with_unit	10303-41		path_feature_component <= shape_aspect shape_definition = shape_aspect shape_definition characterized_definition = shape_definition characterized_definition <= property_definition.definition property_definition <= property_definition_representation.definition { property_definition_representation => shape_definition_representation } property_definition_representation property_definition_representation.used_representation -> {representation => shape_representation => shape_representation_with_parameters} representation representation.items[i] -> {representation_item.name = 'sweep_angle'} representation_item => measure_representation_item <= measure_with_unit => plane_angle_measure_with_unit
PARTIAL_CIRCULAR_PROFILE	partial_circular_profile	10303-522		partial_circular_profile <= shape_aspect

**Table 4 — Mapping table for manufacturing features UoF (continued)**

Application element	AIM element	Source	Rules	Reference path
radius	length_measure_with_unit	10303-41		<pre> partial_circular_profile &lt;=   shape_aspect   shape_definition = shape_aspect   shape_definition characterized_definition = shape_definition characterized_definition &lt;-   property_definition.definition   property_definition &lt;-   property_definition_representation.definition { property_definition_representation =&gt;   shape_definition_representation } property_definition_representation property_definition_representation.used_representation -&gt;   {representation =&gt;   shape_representation =&gt;   shape_representation_with_parameters}   representation   representation.items[j] -&gt;   {representation_item.name = 'radius'}   representation_item =&gt;   measure_representation_item &lt;=   measure_with_unit =&gt;   length_measure_with_unit </pre>

**Table 4 — Mapping table for manufacturing features UoF (continued)**

Application element	AIM element	Source	Rules	Reference path
sweep_angle	plane_angle_measure_with_unit	10303-41		<pre> partial_circular_profile &lt;=   shape_aspect   shape_definition = shape_aspect   shape_definition characterized_definition = shape_definition characterized_definition &lt;-   property_definition.definition   property_definition &lt;-   property_definition_representation.definition { property_definition_representation =&gt;   shape_definition_representation } property_definition_representation property_definition_representation.used_representation -&gt;   {representation =&gt;   shape_representation =&gt;   shape_representation_with_parameters}   representation   representation.items[i] -&gt;   {representation_item.name = 'sweep_angle'}   representation_item =&gt;   measure_representation_item &lt;=   measure_with_unit =&gt;   plane_angle_measure_with_unit </pre>



**Table 4 — Mapping table for manufacturing features UoF (continued)**

Application element	AIM element	Source	Rules	Reference path
PARTIAL_CIRCULAR_SHAPE_PROFILE	outside_profile	10303-522		<pre> outside_profile &lt;= {feature_definition =&gt;   instantiated_feature} feature_definition &lt;=   characterized_object characterized_definition = characterized_object characterized_definition &lt;-   property_definition.definition property_definition =&gt;   product_definition_shape &lt;-   shape_aspect.of_shape   shape_aspect {shape_aspect.description = 'partial circular boundary occurrence'}</pre>
partial_circular_shape_profile to partial_circular_profile (as open_boundary)	PATH			<pre> outside_profile &lt;= feature_definition &lt;=   characterized_object characterized_definition = characterized_object characterized_definition &lt;-   property_definition.definition   property_definition =&gt;   product_definition_shape &lt;-   shape_aspect.of_shape   shape_aspect {shape_aspect.description = 'partial circular boundary occurrence'} shape_aspect.related_shape_aspect {shape_aspect.relationship =&gt;   shape_defining_relationship} {shape_aspect.relationship.description = 'profile usage'} shape_aspect.relationship shape_aspect.relationship.relatng_shape_aspect -&gt;   shape_aspect =&gt;   partial_circular_profile</pre>

**Table 4 — Mapping table for manufacturing features UoF (continued)**

Application element	AIM element	Source	Rules	Reference path
PLANAR_FACE	flat_face	10303-522		<pre> flat_face &lt;= {feature_definition =&gt;   instantiated_feature} feature_definition &lt;= characterized_object                     </pre>
planar_face to linear_path (as course_of_travel)	PATH			<pre> flat_face &lt;= feature_definition &lt;= characterized_object characterized_definition &lt;- property_definition.definition product_definition_shape &lt;- shape_aspect.of_shape {shape_aspect.description = 'course of travel occurrence'} shape_aspect &lt;- shape_aspect.related_shape_aspect {shape_aspect.relationship =&gt;   shape_defining_relationship} {shape_aspect.relationship.name = 'course of travel'} {shape_aspect.relationship.description = \   'path feature component usage'} shape_aspect.relationship shape_aspect.relationship.related_shape_aspect -&gt; {shape_aspect.description = 'linear'} path_feature_component                     </pre>

**Table 4 — Mapping table for manufacturing features UoF (continued)**

Application element	AIM element	Source	Rules	Reference path
planar_face to linear_profile (as removal_boundary)	PATH			<pre> flat_face &lt;= feature_definition &lt;= characterized_object characterized_definition = characterized_object characterized_definition &lt;- property_definition.definition property_definition =&gt; product_definition_shape &lt;- shape_aspect.of_shape {shape_aspect.description = 'removal boundary occurrence'} shape_aspect &lt;- shape_aspect.related_shape_aspect {shape_aspect.relationship =&gt; shape_defining_relationship} {shape_aspect.relationship.name = 'removal boundary'} {shape_aspect.relationship.description = 'profile usage'} shape_aspect.relationship shape_aspect.relationship.relatng_shape_aspect -&gt; shape_aspect =&gt; linear_profile                     </pre>

**Table 4 — Mapping table for manufacturing features UoF (continued)**

Application element	AIM element	Source	Rules	Reference path
planar_face_to_closed_profile (as face_boundary)	PATH			<pre> flat_face &lt;= feature_definition &lt;= characterized_object characterized_definition = characterized_object characterized_definition &lt;- property_definition.definition property_definition =&gt; product_definition_shape &lt;- shape_aspect.of_shape {shape_aspect.description = 'enclosed boundary occurrence'} shape_aspect &lt;- shape_aspect.related_shape_aspect {shape_aspect.relationship =&gt; shape_defining_relationship} {shape_aspect.relationship.name = 'boundary'} {shape_aspect.relationship.description = 'profile usage'} shape_aspect.relationship shape_aspect.relationship.relatng_shape_aspect -&gt; shape_aspect =&gt; (circular_closed_profile) (ngon_closed_profile) (rectangular_closed_profile) (closed_path_profile)                     </pre>

**Table 4 — Mapping table for manufacturing features UoF (continued)**

Application element	AIM element	Source	Rules	Reference path
planar_face_to_boss (as its_boss)	PATH			<pre> flat_face &lt;= feature_definition &lt;= characterized_object characterized_definition = characterized_object characterized_definition &lt;- property_definition.definition property_definition =&gt; product_definition_shape &lt;- shape_aspect.of_shape {shape_aspect =&gt; composite_shape_aspect} shape_aspect &lt;- shape_aspect_relatng_shape_aspect shape_aspect_relationship.description = 'uncut volume'} {shape_aspect_relationship=&gt; feature_component_relationship} shape_aspect_relationship shape_aspect_relationship.related_shape_aspect-&gt; shape_aspect =&gt; instanced_feature &lt;= feature_definition =&gt; boss                     </pre>

**Table 4 — Mapping table for manufacturing features UoF (continued)**

Application element	AIM element	Source	Rules	Reference path
removal_depth	length_measure_with_unit	10303-41		<pre> flat_face &lt;= feature_definition &lt;= characterized_object characterized_definition = characterized_object characterized_definition &lt;- property_definition.definition { property_definition =&gt; product_definition_shape } property_definition &lt;- property_definition_representation.definition { property_definition_representation =&gt; shape_definition_representation } property_definition_representation property_definition_representation.used_representation -&gt; {representation =&gt; shape_representation =&gt; shape_representation_with_parameters} representation representation.items[i] -&gt; {representation_item.name = 'removal depth' } representation_item =&gt; measure_representation_item &lt;= measure_with_unit =&gt; length_measure_with_unit                     </pre>

**Table 4 — Mapping table for manufacturing features UoF (continued)**

Application element	AIM element	Source	Rules	Reference path
removal_direction	direction	10303-42		<pre> flat_face &lt;= feature_definition &lt;= characterized_object characterized_definition = characterized_object characterized_definition &lt;- property_definition.definition property_definition &lt;- {property_definition =&gt; product_definition_shape} property_definition.definition property_definition_representation property_definition_representation.used_representation -&gt; representation { representation.name = 'removal direction' } { representation =&gt; shape_representation=&gt; direction_shape_representation } representation.items[i] -&gt; representation_item =&gt; geometric_representation_item =&gt; direction                     </pre>
PLANAR_POCKET_BOTTOM_CONDITION	pocket_bottom	10303-522		<pre> pocket_bottom &lt;= shape_aspect { shape_aspect.description = 'planar' }                     </pre>
PLANAR_PROFILE_FLOOR	profile_floor	10303-522		<pre> profile_floor &lt;= shape_aspect { shape_aspect.description = 'planar' }                     </pre>

**Table 4 — Mapping table for manufacturing features UoF (continued)**

Application element	AIM element	Source	Rules	Reference path
floor	plane	10303-42		<pre> profile_floor &lt;=   shape_aspect   shape_definition = shape_aspect   shape_definition characterized_definition = shape_definition characterized_definition &lt;-   property_definition.definition   property_definition &lt;-   property_definition_representation.definition   property_definition_representation   property_definition_representation.used_representation -&gt;   { representation =&gt;     shape_representation=&gt;     planar_shape_representation }   representation.name = 'floor' }   representation.items[i] -&gt;   representation_item =&gt;   geometric_representation_item =&gt;     surface =&gt;     elementary_surface =&gt;     plane </pre>
POCKET	pocket	10303-522		<pre> pocket &lt;=   {feature_definition =&gt;     instantiated_feature}   feature_definition &lt;=   characterized_object </pre>



**Table 4 — Mapping table for manufacturing features UoF (continued)**

Application element	AIM element	Source	Rules	Reference path
<p>pocket to boss (as its_boss)</p>	<p>PATH</p>			<pre> pocket &lt;= feature_definition &lt;= characterized_object characterized_definition = characterized_object characterized_definition &lt;- property_definition.definition property_definition =&gt; product_definition_shape &lt;- shape_aspect.of_shape {shape_aspect =&gt; composite_shape_aspect} shape_aspect &lt;- shape_aspect_relatng_shape_aspect shape_aspect_relatng_shape_aspect {shape_aspect_relatng_shape_aspect = 'uncut volume'} {shape_aspect_relatng_shape_aspect =&gt; feature_component_relatng_shape_aspect} shape_aspect_relatng_shape_aspect_relatng_shape_aspect-&gt; shape_aspect =&gt; instanced_feature &lt;= feature_definition =&gt; boss                     </pre>

**Table 4 — Mapping table for manufacturing features UoF (continued)**

Application element	AIM element	Source	Rules	Reference path
<p>pocket to angle_taper (as slope)</p>	<p>PATH</p>			<pre> pocket &lt;= feature_definition &lt;= characterized_object characterized_definition = characterized_object characterized_definition &lt;- property_definition.definition property_definition =&gt; product_definition_shape &lt;- shape_aspect.of_shape {shape_aspect.description = 'change in boundary occurrence'} shape_aspect &lt;- shape_aspect.related_shape_aspect {shape_aspect.relationship =&gt; feature_component_relationship} {shape_aspect.relationship.description = 'taper usage'} shape_aspect.relationship shape_aspect.relationship.relation_shape_aspect -&gt; {shape_aspect.description = 'angle taper'} shape_aspect =&gt; taper                     </pre>

**Table 4 — Mapping table for manufacturing features UoF (continued)**

Application element	AIM element	Source	Rules	Reference path
<p>pocket to pocket_bottom_condition (as bottom_condition)</p>	<p>PATH</p>			<pre> pocket &lt;= feature_definition &lt;= characterized_object characterized_definition = characterized_object characterized_definition &lt;- property_definition.definition property_definition =&gt; product_definition_shape &lt;- shape_aspect.of_shape { shape_aspect.description = 'bottom condition occurrence' } shape_aspect &lt;- shape_aspect.related_shape_aspect { shape_aspect.relationship =&gt; feature_component_relationship } { shape_aspect.relationship.description = 'pocket bottom usage' } shape_aspect.relationship shape_aspect.relationship.relatng_shape_aspect -&gt; shape_aspect =&gt; pocket_bottom                     </pre>

**Table 4 — Mapping table for manufacturing features UoF (continued)**

Application element	AIM element	Source	Rules	Reference path
<p>planar_radius</p> <p>See NOTE 10.</p>	<p>length_measure_with_unit</p>	<p>10303-41</p>		<pre> pocket &lt;= characterized_object characterized_definition = characterized_object characterized_definition &lt;- property_definition.definition property_definition =&gt; product_definition_shape &lt;- shape_aspect.of_shape shape_aspect &lt;- shape_aspect.related_shape_shape_aspect shape_aspect_relationship.related_shape_shape_aspect { shape_aspect_relationship =&gt; feature_component_relationship } shape_aspect_relationship shape_aspect_relationship.relatng_shape_shape_aspect -&gt; { shape_aspect =&gt; pocket_bottom } shape_aspect shape_definition = shape_aspect shape_definition characterized_definition = shape_definition characterized_definition &lt;- property_definition.definition property_definition &lt;- property_definition.definition property_definition_representation.definition { property_definition_representation =&gt; shape_definition_representation } property_definition_representation property_definition_representation.used_representation -&gt; {representation =&gt; shape_representation_with_parameters} representation representation.items[i] -&gt; {representation_item.name = 'radius' } representation_item =&gt; measure_representation_item &lt;= length_measure_with_unit                     </pre>

**Table 4 — Mapping table for manufacturing features UoF (continued)**

Application element	AIM element	Source	Rules	Reference path
orthogonal_radius	length_measure_with_unit	10303-41		<pre> pocket &lt;= feature_definition &lt;= characterized_object characterized_definition = characterized_object characterized_definition &lt;- property_definition.definition { property_definition =&gt; product_definition_shape } property_definition &lt;- property_definition_representation.definition { property_definition_representation =&gt; shape_definition_representation } property_definition_representation property_definition_representation.used_representation -&gt; {representation =&gt; shape_representation =&gt; shape_representation_with_parameters} representation representation.items[i] -&gt; {representation_item.name = 'orthogonal fillet radius'} representation_item =&gt; measure_representation_item &lt;= measure_with_unit =&gt; length_measure_with_unit                     </pre>

**Table 4 — Mapping table for manufacturing features UoF (continued)**

Application element	AIM element	Source	Rules	Reference path
bottom_at_path_end  See NOTE 12, preferred mapping  #1: if value is true  #2: if value is false	shape_aspect_relationship.name	10303-41		<pre>                     pocket &lt;=                     feature_definition &lt;=                     characterized_object                     characterized_definition = characterized_object                     characterized_definition &lt;-                     property_definition.definition                     property_definition =&gt;                     product_definition_shape &lt;-                     shape_aspect.of_shape                     {shape_aspect.description = 'bottom condition occurrence'}                     shape_aspect &lt;-                     shape_aspect_related_shape_aspect                     {shape_aspect_relationship =&gt;                     feature_component_relationship}                     shape_aspect_relationship                     shape_aspect_relationship.name                     { #1: (shape_aspect_relationship.name = 'pocket depth end')                     #2: (shape_aspect_relationship.name = 'pocket depth start') }                 </pre>

**Table 4 — Mapping table for manufacturing features UoF (continued)**

Application element	AIM element	Source	Rules	Reference path
<p>bottom_at_path_end</p> <p>See NOTE 12, alternate mapping based on observed AP 224 usage</p> <p>#1: if value is true</p> <p>#2: if value is false</p>	<p>descriptive_representation_item.-description</p>	<p>10303-45</p>		<pre> pocket &lt;=   characterized_object   characterized_definition = characterized_object   characterized_definition &lt;-   property_definition.definition   product_definition_shape &lt;-   shape_definition_shape &lt;-   shape_aspect.of_shape   {shape_aspect.description = 'bottom condition occurrence'}   shape_aspect &lt;-   shape_aspect.related_shape_aspect   {shape_aspect_relationship =&gt; feature_component_relationship}   shape_aspect_relationship   shape_aspect_relationship.relatng_shape_aspect -&gt;   shape_aspect   {shape_aspect =&gt; pocket_bottom}   shape_definition = shape_aspect   shape_definition   characterized_definition = shape_definition   characterized_definition &lt;-   property_definition.definition   property_definition &lt;-   property_definition.definition   property_definition_representation.definition   property_definition_representation   property_definition_representation.used_representation -&gt;   {representation =&gt; shape_representation_with_parameters}   representation   representation.items[i] -&gt;   {representation_item.name = 'pocket bottom orientation'}   representation_item =&gt;   descriptive_representation_item   descriptive_representation_item.description   {#1: (descriptive_representation_item.description = \   'pocket depth end')   #2: (descriptive_representation_item.description = \   'pocket depth start') }                     </pre>

**Table 4 — Mapping table for manufacturing features UoF (continued)**

Application element	AIM element	Source	Rules	Reference path
<p>pocket to linear_path (as course_of_travel)</p>	<p>PATH</p>			<pre> pocket &lt;= feature_definition &lt;= characterized_object characterized_definition = characterized_object characterized_definition &lt;- property_definition.definition property_definition =&gt; product_definition_shape &lt;- shape_aspect.of_shape { shape_aspect.description = 'pocket depth occurrence' } shape_aspect &lt;- shape_aspect.related_shape_aspect { shape_aspect.relationship =&gt; shape_defining_relationship } { shape_aspect.relationship.name = 'pocket depth' } { shape_aspect.relationship.description = \ 'path feature component usage' } shape_aspect.relationship shape_aspect.relationship.relatng_shape_aspect -&gt; { shape_aspect.description = 'linear' } shape_aspect =&gt; path_feature_component                     </pre>



**Table 4 — Mapping table for manufacturing features UoF (continued)**

Application element	AIM element	Source	Rules	Reference path
top_fillet_radius	length_measure_with_unit	10303-41		<pre> pocket &lt;= feature_definition &lt;= characterized_object characterized_definition = characterized_object characterized_definition &lt;- property_definition.definition { property_definition =&gt; product_definition_shape } property_definition &lt;- property_definition.definition { property_definition_representation =&gt; shape_definition_representation } property_definition_representation property_definition_representation.used_representation -&gt; {representation =&gt; shape_representation =&gt; shape_representation_with_parameters} representation representation.items[i] -&gt; {representation_item.name = 'fillet radius'} representation_item =&gt; measure_representation_item &lt;= measure_with_unit =&gt; length_measure_with_unit                     </pre>
POCKET_BOTTOM_CONDITION	pocket_bottom	10303-522		<pre> pocket_bottom &lt;= shape_aspect { shape_aspect_of_shape -&gt; product_definition_shape &lt;= property_definition property_definition.definition -&gt; characterized_definition characterized_definition =&gt; feature_component_definition }                     </pre>

**Table 4 — Mapping table for manufacturing features UoF (continued)**

Application element	AIM element	Source	Rules	Reference path
PROFILE	(circular_closed_profile) (closed_path_profile) (ngon_closed_profile) (rectangular_closed_profile) (linear_profile) (open_path_profile) (partial_circular_profile) (rounded_u_profile) (square_u_profile) (tee_profile) (vee_profile)	10303-522 10303-522 10303-522 10303-522 10303-522 10303-522 10303-522 10303-522 10303-522 10303-522		(circular_closed_profile <=>) (closed_path_profile <=>) (ngon_closed_profile <=>) (rectangular_closed_profile <=>) (linear_profile <=>) (open_path_profile <=>) (partial_circular_profile <=>) (rounded_u_profile <=>) (square_u_profile <=>) (tee_profile <=>) (vee_profile <=>) shape_aspect {shape_aspect shape_aspect.of_shape-> product_definition_shape <=> property_definition property_definition.definition-> characterized_definition characterized_definition = characterized_object characterized_object => feature_component_definition}

**Table 4 — Mapping table for manufacturing features UoF (continued)**

Application element	AIM element	Source	Rules	Reference path
placement	axis2_placement_3d	10303-42		<pre> (circular_closed_profile &lt;=&gt;) (closed_path_profile &lt;=&gt;) (ngon_closed_profile &lt;=&gt;) (rectangular_closed_profile &lt;=&gt;)   (linear_profile &lt;=&gt;)   (open_path_profile &lt;=&gt;)   (partial_circular_profile &lt;=&gt;)   (rounded_u_profile &lt;=&gt;)   (square_u_profile &lt;=&gt;)   (tee_profile &lt;=&gt;)   (vee_profile &lt;=&gt;)   shape_aspect   shape_definition = shape_aspect   shape_definition characterized_definition = shape_definition characterized_definition &lt;-   property_definition.definition   property_definition &lt;-   property_definition_representation.definition   { property_definition_representation =&gt;   shape_definition_representation }   property_definition_representation   property_definition_representation.used_representation -&gt;   {representation =&gt;   shape_representation =&gt;   shape_representation_with_parameters}   representation   representation.items[i] -&gt;   {representation_item.name = 'orientation'? }   representation_item =&gt;   geometric_representation_item =&gt;   placement =&gt;   axis2_placement_3d </pre>

**Table 4 — Mapping table for manufacturing features UoF (continued)**

Application element	AIM element	Source	Rules	Reference path
PROFILE_FEATURE	outside_profile	10303-522		outside_profile <= {feature_definition => instanced_feature} feature_definition <= characterized_object

**Table 4 — Mapping table for manufacturing features UoF (continued)**

Application element	AIM element	Source	Rules	Reference path
<p>profile_feature to linear_path (as profile_swept_shape)</p> <p>#1: if profile_feature is a general_outside_profile</p> <p>#2: if profile_feature is general_shape_profile</p> <p>#3: if profile_feature is a partial_circular_shape_profile</p> <p>#4: if profile_feature is a circular_closed_shape_profile</p> <p>#5: if profile_feature is a rectangular_open_shape_profile</p> <p>#6: if profile_feature is a rectangular_closed_shape_profile</p> <p>See NOTE 13</p>	<p>PATH</p>			<pre> outside_profile&lt;= feature_definition &lt;= characterized_object characterized_definition = characterized_object characterized_definition &lt;- property_definition.definition property_definition =&gt; product_definition_shape &lt;- shape_aspect.of_shape shape_aspect.description = 'outside boundary' { #1: (shape_aspect.description = 'outside boundary') #2: (shape_aspect.description = 'complex boundary occurrence') #3: (shape_aspect.description = \ 'partial circular boundary occurrence') #4: (shape_aspect.description = \ 'closed circular boundary occurrence') #5: (shape_aspect.description = \ 'open rectangular boundary occurrence') #6: (shape_aspect.description = \ 'closed rectangular boundary occurrence')} shape_aspect &lt;- shape_aspect.related_shape_aspect {shape_aspect.relationship =&gt; shape_defining_relationship} {shape_aspect.relationship.name = 'profile swept shape'} {shape_aspect.relationship.description = \ 'path feature component usage'} shape_aspect.relationship shape_aspect.relationship.related_shape_aspect -&gt; { shape_aspect.description = 'linear' } shape_aspect =&gt; path_feature_component                     </pre>

**Table 4 — Mapping table for manufacturing features UoF (continued)**

Application element	AIM element	Source	Rules	Reference path
PROFILE_FLOOR	profile_floor	10303-522		<pre> profile_floor &lt;=   shape_aspect   {shape_aspect.of_shape -&gt;     product_definition_shape &lt;=       property_definition       property_definition.definition -&gt;         characterized_definition         characterized_definition = characterized_object         characterized_object =&gt;           feature_component_definition} </pre>
floor_radius	length_measure_with_unit	10303-41		<pre> profile_floor &lt;=   shape_aspect   shape_definition = shape_aspect   shape_definition   characterized_definition = shape_definition   characterized_definition &lt;-     property_definition.definition     property_definition &lt;-       property_definition.definition       {property_definition_representation.definition         {property_definition_representation =&gt;           shape_definition_representation }         property_definition_representation         property_definition_representation.used_representation -&gt;           {representation =&gt;             shape_representation =&gt;               shape_representation_with_parameters}           representation           representation.items[i] -&gt;             {representation_item.name = 'radius'}             representation_item =&gt;               measure_representation_item &lt;=                 measure_with_unit =&gt;                   length_measure_with_unit </pre>

**Table 4 — Mapping table for manufacturing features UoF (continued)**

Application element	AIM element	Source	Rules	Reference path
start_or_end #1: if value is true #2: if value is false	descriptive_representation_- item.description	10303-45		<pre> profile_floor &lt;=   shape_aspect   shape_definition = shape_aspect   shape_definition characterized_definition = shape_definition characterized_definition &lt;-   property_definition.definition   property_definition &lt;-   property_definition_representation.definition   { property_definition_representation =&gt;   shape_definition_representation }   property_definition_representation property_definition_representation.used_representation -&gt;   {representation =&gt;   shape_representation =&gt;   shape_representation_with_parameters}   representation   representation.items[i] -&gt;   {representation_item.name = 'shape profile floor orientation'}   representation_item =&gt;   descriptive_representation_item   descriptive_representation_item.description   {#1: (descriptive_representation_item.description = \   'shape profile end')   #2: (descriptive_representation_item.description = \   'shape profile start') }</pre>
RADIUSED_POCKET_BOTTOM_- CONDITION	pocket_bottom	10303-522		<pre> pocket_bottom &lt;=   shape_aspect   { shape_aspect.description = 'radiused' }</pre>

**Table 4 — Mapping table for manufacturing features UoF (continued)**

Application element	AIM element	Source	Rules	Reference path
floor_radius	length_measure_with_unit	10303-41		<pre> pocket_bottom &lt;=   shape_aspect   shape_definition = shape_aspect   shape_definition characterized_definition = shape_definition characterized_definition &lt;-   property_definition.definition   property_definition &lt;-   property_definition_representation.definition   { property_definition_representation =&gt;   shape_definition_representation }   property_definition_representation property_definition_representation.used_representation -&gt;   {representation =&gt;   shape_representation_with_parameters}   representation   representation.items[i] -&gt;   {representation_item.name = 'pocket bottom radius'}   representation_item =&gt;   measure_representation_item &lt;=   measure_with_unit =&gt;   length_measure_with_unit                     </pre>



**Table 4 — Mapping table for manufacturing features UoF (continued)**

Application element	AIM element	Source	Rules	Reference path
floor_radius_center	cartesian_point	10303-42		<pre> pocket_bottom &lt;=   shape_aspect   shape_definition = shape_aspect   shape_definition characterized_definition = shape_definition characterized_definition &lt;-   property_definition.definition   property_definition &lt;-   property_definition_representation.definition   { property_definition_representation =&gt;   shape_definition_representation } property_definition_representation property_definition_representation.used_representation -&gt;   representation   {representation.name = 'pocket bottom radius location' }   { representation =&gt;   shape_representation=&gt;   location_shape_representation }   representation.items[i] -&gt;   representation_item =&gt;   geometric_representation_item =&gt;   point =&gt;   cartesian_point </pre>
RADIUSED_SLOT_END_TYPE	slot_end	10303-522		<pre> slot_end &lt;=   shape_aspect   { shape_aspect.description = 'radiused' } </pre>
RECTANGULAR_CLOSED_PROFILE	rectangular_closed_profile	10303-522		<pre> rectangular_closed_profile &lt;=   shape_aspect </pre>

**Table 4 — Mapping table for manufacturing features UoF (continued)**

Application element	AIM element	Source	Rules	Reference path
profile_width	length_measure_with_unit	10303-41		<pre> rectangular_closed_profile &lt;=   shape_aspect   shape_definition = shape_aspect   shape_definition characterized_definition = shape_definition characterized_definition &lt;-   property_definition.definition   property_definition &lt;-   property_definition_representation.definition   { property_definition_representation =&gt;   shape_definition_representation }   property_definition_representation property_definition_representation.used_representation -&gt;   {representation =&gt;   shape_representation =&gt;   shape_representation_with_parameters}   representation   representation.items[i] -&gt;   {representation_item.name = 'width'}   representation_item =&gt;   measure_representation_item &lt;=   measure_with_unit =&gt;   length_measure_with_unit                     </pre>

**Table 4 — Mapping table for manufacturing features UoF (continued)**

Application element	AIM element	Source	Rules	Reference path
profile_length	length_measure_with_unit	10303-41		<pre> rectangular_closed_profile &lt;=   shape_aspect   shape_definition = shape_aspect   shape_definition characterized_definition = shape_definition characterized_definition &lt;-   property_definition.definition   property_definition &lt;-   property_definition_representation.definition   { property_definition_representation =&gt;   shape_definition_representation }   property_definition_representation property_definition_representation.used_representation -&gt;   {representation =&gt;   shape_representation =&gt;   shape_representation_with_parameters}   representation   representation.items[j] -&gt;   {representation_item.name = 'length'}   representation_item =&gt;   measure_representation_item &lt;=   measure_with_unit =&gt;   length_measure_with_unit </pre>

**Table 4 — Mapping table for manufacturing features UoF (continued)**

Application element	AIM element	Source	Rules	Reference path
RECTANGULAR_CLOSED_SHAPE_PROFILE	outside_profile	10303-522		<pre> outside_profile &lt;= {feature_definition =&gt;   instantiated_feature} feature_definition &lt;=   characterized_object characterized_definition = characterized_object characterized_definition &lt;-   property_definition.definition property_definition =&gt;   product_definition_shape &lt;-   shape_aspect.of_shape   shape_aspect   shape_aspect {shape_aspect.description = \ 'closed rectangular boundary occurrence'}</pre>
rectangular_closed_shape_profile to rectangular_closed_profile (as closed_boundary)	PATH			<pre> outside_profile &lt;= feature_definition &lt;=   characterized_object characterized_definition = characterized_object characterized_definition &lt;-   property_definition.definition property_definition =&gt;   product_definition_shape &lt;-   shape_aspect.of_shape   shape_aspect.description = \ 'closed rectangular boundary occurrence' }   shape_aspect &lt;-   shape_aspect.relationship.related_shape_aspect   {shape_aspect.relationship =&gt;   shape_defining_relationship} {shape_aspect.relationship.description = 'profile usage' }   shape_aspect.relationship   shape_aspect.relationship.relatng_shape_aspect -&gt;   shape_aspect =&gt;   rectangular_closed_profile</pre>

**Table 4 — Mapping table for manufacturing features UoF (continued)**

Application element	AIM element	Source	Rules	Reference path
RECTANGULAR_OFFSET	shape_aspect	10303-41		<pre> shape_aspect.related_shape_aspect   shape_aspect.relationship =&gt;     feature_component_relationship =&gt;       pattern_offset_membership]     [shape_aspect &lt;-       shape_aspect.relationship.related_shape_aspect         {shape_aspect.relationship =&gt;           feature_component_relationship}       shape_aspect.relationship.related_shape_aspect-&gt;         shape_aspect =&gt;           modified_pattern]                     </pre>
offset_direction	direction	10303-42		<pre> shape_aspect   shape_definition = shape_aspect     shape_definition   characterized_definition = shape_definition     characterized_definition &lt;-       property_definition.definition     property_definition &lt;-       property_definition.definition   property_definition_representation.definition   property_definition_representation   property_definition_representation.used_representation -&gt;     representation     {representation.name = 'offset direction'}     { representation =&gt;       shape_representation=&gt;         direction_shape_representation }     representation.items[] -&gt;       representation_item =&gt;         geometric_representation_item =&gt;           direction                     </pre>

**Table 4 — Mapping table for manufacturing features UoF (continued)**

Application element	AIM element	Source	Rules	Reference path
offset_distance	length_measure_with_unit	10303-41		<pre> shape_definition = shape_aspect shape_definition characterized_definition = shape_definition characterized_definition &lt;- property_definition.definition property_definition &lt;- property_definition_representation.definition { property_definition_representation =&gt; shape_definition_representation } property_definition_representation property_definition_representation.used_representation -&gt; {representation =&gt; shape_representation =&gt; shape_representation_with_parameters} representation representation.items[i] -&gt; {representation_item name = 'offset distance'} representation_item =&gt; measure_representation_item &lt;= measure_with_unit =&gt; length_measure_with_unit                     </pre>

**Table 4 — Mapping table for manufacturing features UoF (continued)**

Application element	AIM element	Source	Rules	Reference path
row_index	count_measure	10303-41		<pre> shape_definition = shape_aspect shape_definition characterized_definition = shape_definition characterized_definition &lt;- property_definition.definition property_definition &lt;- property_definition_representation.definition { property_definition_representation =&gt; shape_definition_representation } property_definition_representation property_definition_representation.used_representation -&gt; {representation =&gt; shape_representation =&gt; shape_representation_with_parameters} representation representation.items[i] -&gt; {representation_item.name = 'row index'} representation_item =&gt; measure_representation_item &lt;= measure_with_unit measure_with_unit.value_component -&gt; measure_value measure_value = count_measure count_measure                     </pre>

**Table 4 — Mapping table for manufacturing features UoF (continued)**

Application element	AIM element	Source	Rules	Reference path
column_index	count_measure	10303-41		<pre> shape_definition = shape_aspect shape_definition characterized_definition = shape_definition characterized_definition &lt;- property_definition.definition property_definition &lt;- property_definition_representation.definition { property_definition_representation =&gt; shape_definition_representation } property_definition_representation property_definition_representation.used_representation -&gt; { representation =&gt; shape_representation =&gt; shape_representation_with_parameters} representation representation.items[i] -&gt; { representation_item.name = 'column index'? representation_item =&gt; measure_representation_item &lt;= measure_with_unit measure_with_unit.value_component -&gt; measure_value measure_value = count_measure count_measure                     </pre>



**Table 4 — Mapping table for manufacturing features UoF (continued)**

Application element	AIM element	Source	Rules	Reference path
RECTANGULAR_OMIT	shape_aspect	10303-41		<pre> [shape_aspect &lt;- shape_aspect.relationship.related_shape_aspect shape_aspect.relationship =&gt; feature_component.relationship =&gt; pattern.omit.membership] [shape_aspect &lt;- shape_aspect.relationship.related_shape_aspect {shape_aspect.relationship =&gt; feature_component.relationship} shape_aspect.relationship.relatng_shape_aspect-&gt; shape_aspect =&gt; modified_pattern]                     </pre>

**Table 4 — Mapping table for manufacturing features UoF (continued)**

Application element	AIM element	Source	Rules	Reference path
row_index	count_measure	10303-41		<pre> shape_definition = shape_aspect shape_definition characterized_definition = shape_definition characterized_definition &lt;- property_definition.definition property_definition &lt;- property_definition_representation.definition { property_definition_representation =&gt; shape_definition_representation } property_definition_representation property_definition_representation.used_representation -&gt; {representation =&gt; shape_representation =&gt; shape_representation_with_parameters} representation representation.items[i] -&gt; {representation_item.name = 'row index'} representation_item =&gt; measure_representation_item &lt;= measure_with_unit measure_with_unit.value_component -&gt; measure_value measure_value = count_measure count_measure                     </pre>

**Table 4 — Mapping table for manufacturing features UoF (continued)**

Application element	AIM element	Source	Rules	Reference path
column_index	count_measure	10303-41		<pre> shape_definition = shape_aspect shape_definition characterized_definition = shape_definition characterized_definition &lt;- property_definition.definition property_definition &lt;- property_definition_representation.definition { property_definition_representation =&gt; shape_definition_representation } property_definition_representation property_definition_representation.used_representation -&gt; {representation =&gt; shape_representation =&gt; shape_representation_with_parameters} representation representation.items[i] -&gt; {representation_item.name = 'column index'? representation_item =&gt; measure_representation_item &lt;= measure_with_unit measure_with_unit.value_component -&gt; measure_value measure_value = count_measure count_measure                     </pre>

**Table 4 — Mapping table for manufacturing features UoF (continued)**

Application element	AIM element	Source	Rules	Reference path
RECTANGULAR_OPEN_SHAPE_PROFILE	outside_profile	10303-522		<pre> outside_profile &lt;= {feature_definition =&gt;   instantiated_feature} feature_definition &lt;=   characterized_object characterized_definition = characterized_object characterized_definition &lt;-   property_definition.definition property_definition =&gt;   product_definition_shape &lt;-   shape_aspect.of_shape   shape_aspect   shape_aspect {shape_aspect.description = \ 'open rectangular boundary occurrence'}</pre>
rectangular_open_shape_profile to square_u_profile (as open_boundary)	PATH			<pre> outside_profile &lt;= feature_definition &lt;=   characterized_object characterized_definition = characterized_object characterized_definition &lt;-   property_definition.definition   property_definition =&gt;   product_definition_shape &lt;-   shape_aspect.of_shape   shape_aspect.description = \ 'open rectangular boundary occurrence'   shape_aspect &lt;-   shape_aspect.related_shape_aspect   {shape_aspect_relationship =&gt;   shape_defining_relationship} {shape_aspect_relationship.description = 'profile usage'}   shape_aspect_relationship   shape_aspect_relationship.relatng_shape_aspect -&gt;   shape_aspect =&gt;   square_u_profile</pre>

**Table 4 — Mapping table for manufacturing features UoF (continued)**

Application element	AIM element	Source	Rules	Reference path
RECTANGULAR_PATTERN	rectangular_pattern	10303-522		<pre> rectangular_pattern &lt;=   replicate_feature &lt;=     {feature_definition =&gt;       instantiated_feature} feature_definition &lt;=   characterized_object           </pre>
spacing	length_measure_with_unit	10303-41		<pre> rectangular_pattern &lt;=   replicate_feature &lt;=     feature_definition &lt;=       characterized_object characterized_definition = characterized_object characterized_definition &lt;-   property_definition.definition   { &gt;property_definition =&gt;     product_definition_shape }   property_definition &lt;-     property_definition_representation.definition   { &gt;property_definition_representation =&gt;     shape_definition_representation }   property_definition_representation property_definition_representation.used_representation -&gt;   {representation =&gt;     shape_representation =&gt;     shape_representation_with_parameters}   representation   {representation.items[j] -&gt;     representation_item =&gt;     measure_representation_item &lt;=     measure_with_unit =&gt;     length_measure_with_unit           </pre>

**Table 4 — Mapping table for manufacturing features UoF (continued)**

Application element	AIM element	Source	Rules	Reference path
its_direction	direction	10303-42		<pre> rectangular_pattern &lt;=   replicate_feature &lt;=     feature_definition &lt;=       characterized_object         characterized_definition = characterized_object           characterized_definition &lt;-             property_definition.definition               property_definition &lt;-                 {property_definition =&gt;                   product_definition_shape}                 property_definition_representation.definition                   property_definition_representation                     property_definition_representation.used_representation -&gt;                       representation                         {representation.name = 'column layout direction'}                           {representation =&gt;                             shape_representation=&gt;                               direction_shape_representation }                                 representation.items[i] -&gt;                                   representation_item =&gt;                                     geometric_representation_item =&gt;                                       direction                     </pre>

**Table 4 — Mapping table for manufacturing features UoF (continued)**

Application element	AIM element	Source	Rules	Reference path
number_of_rows	count_measure	10303-41		<pre> rectangular_pattern &lt;=   replicate_feature &lt;=     feature_definition &lt;=       characterized_object         characterized_definition = characterized_object           characterized_definition &lt;-             property_definition.definition               { property_definition =&gt;                 product_definition_shape }             property_definition &lt;-               property_definition.definition                 { property_definition_representation =&gt;                   shape_definition_representation }               property_definition_representation                 { property_definition_representation.used_representation -&gt;                   {representation =&gt;                     shape_representation =&gt;                       shape_representation_with_parameters}                     representation                       representation.items[i] -&gt;                         {representation_item.name = 'number of rows'}                       representation_item =&gt;                         measure_representation_item                           {measure_representation_item &lt;=                             measure_with_unit                               measure_with_unit_value_component -&gt;                                 measure_value                                   measure_value = count_measure                                     count_measure} </pre>

**Table 4 — Mapping table for manufacturing features UoF (continued)**

Application element	AIM element	Source	Rules	Reference path
number_of_columns	count_measure	10303-41		<pre> rectangular_pattern &lt;=   replicate_feature &lt;=     feature_definition &lt;=       characterized_object         characterized_definition = characterized_object           characterized_definition &lt;-             property_definition.definition               { property_definition =&gt;                 product_definition_shape }                 property_definition &lt;-                   property_definition.definition                     { property_definition_representation =&gt;                       shape_definition_representation }                     property_definition_representation                       property_definition_representation.used_representation -&gt;                         {representation =&gt;                           shape_representation =&gt;                             shape_representation_with_parameters}                             representation                               representation.items[i] -&gt;                                 {representation_item.name = 'number of columns'}                                   representation_item =&gt;                                     measure_representation_item                                       {measure_representation_item &lt;=   measure_with_unit   measure_with_unit.value_component -&gt;   measure_value   measure_value = count_measure   count_measure} </pre>



**Table 4 — Mapping table for manufacturing features UoF (continued)**

Application element	AIM element	Source	Rules	Reference path
row_spacing	length_measure_with_unit	10303-41		<pre> rectangular_pattern &lt;=   replicate_feature &lt;=     feature_definition &lt;=       characterized_object         characterized_definition = characterized_object           characterized_definition &lt;-             property_definition.definition               { property_definition =&gt;                 product_definition_shape }             property_definition &lt;-               property_definition_representation.definition                 { property_definition_representation =&gt;                   shape_definition_representation }               property_definition_representation                 property_definition_representation.used_representation -&gt;                   {representation =&gt;                     shape_representation =&gt;                       shape_representation_with_parameters}                     representation                       representation.items[i] -&gt;                         {representation_item.name = 'row spacing'}                           representation_item =&gt;                             measure_representation_item &lt;=                               measure_with_unit =&gt;                                 length_measure_with_unit                     </pre>

**Table 4 — Mapping table for manufacturing features UoF (continued)**

Application element	AIM element	Source	Rules	Reference path
row_layout_direction	direction	10303-42		<pre> rectangular_pattern &lt;=   replicate_feature &lt;=     feature_definition &lt;=       characterized_object         characterized_definition = characterized_object           characterized_definition &lt;-             property_definition.definition               {property_definition =&gt;                 product_definition_shape }             property_definition &lt;-               property_definition_representation.definition                 property_definition_representation                   property_definition_representation.used_representation -&gt;                     representation                       {representation.name = 'row layout direction'}                         { representation =&gt;                           shape_representation =&gt;                             direction_shape_representation }                           representation.items[i] -&gt;                             representation_item =&gt;                               geometric_representation_item =&gt;                                 direction                     </pre>

**Table 4 — Mapping table for manufacturing features UoF (continued)**

Application element	AIM element	Source	Rules	Reference path
rectangular_pattern to rectangular_offset (as relocated_base_feature)	PATH			<pre>                     rectangular_pattern &lt;=                     replicate_feature &lt;=                     feature_definition &lt;=                     characterized_object                     characterized_definition = characterized_object                     characterized_definition &lt;-                     property_definition.definition                     property_definition =&gt;                     product_definition_shape &lt;-                     shape_aspect.of_shape                     shape_aspect &lt;-                     [shape_aspect_relationship.relatng_shape_aspect                     {shape_aspect_relationship =&gt;                     feature_component_relationship =&gt;                     pattern_offset_membership}                     shape_aspect_relationship                     shape_aspect_relationship.related_shape_aspect -&gt;                     shape_aspect]                     [shape_aspect_relationship.related_shape_aspect                     {shape_aspect_relationship =&gt;                     feature_component_relationship}                     {shape_aspect_relationship.description = 'base pattern'}                     shape_aspect_relationship.related_shape_aspect-&gt;                     shape_aspect &lt;-                     {shape_aspect =&gt;                     modified_pattern}                     shape_aspect_relationship.relatng_shape_aspect                     {shape_aspect_relationship =&gt;                     feature_component_relationship}                     {shape_aspect_relationship.description = 'modified pattern'}                     shape_aspect_relationship.related_shape_aspect-&gt;                     shape_aspect]                     </pre>

**Table 4 — Mapping table for manufacturing features UoF (continued)**

Application element	AIM element	Source	Rules	Reference path
rectangular_pattern to rectangular_omit (as missing_base_feature)	PATH			<pre>                     rectangular_pattern &lt;=                     replicate_feature &lt;=                     feature_definition &lt;=                     characterized_object                     characterized_definition = characterized_object                     characterized_definition &lt;-                     property_definition.definition                     property_definition =&gt;                     product_definition_shape &lt;-                     shape_aspect.of_shape                     shape_aspect &lt;-                     [shape_aspect_relationship.relatng_shape_aspect                     {shape_aspect_relationship =&gt;                     feature_component_relationship =&gt;                     pattern_omit_membership}                     shape_aspect_relationship                     shape_aspect_relationship.related_shape_aspect -&gt;                     shape_aspect]                     [shape_aspect_relationship.related_shape_aspect                     {shape_aspect_relationship =&gt;                     feature_component_relationship}                     {shape_aspect_relationship.description = 'base pattern'}                     shape_aspect_relationship.related_shape_aspect-&gt;                     shape_aspect &lt;-                     {shape_aspect =&gt;                     modified_pattern}                     shape_aspect_relationship.relatng_shape_aspect                     {shape_aspect_relationship =&gt;                     feature_component_relationship}                     {shape_aspect_relationship.description = 'modified pattern'}                     shape_aspect_relationship.related_shape_aspect-&gt;                     shape_aspect]                     </pre>

**Table 4 — Mapping table for manufacturing features UoF (continued)**

Application element	AIM element	Source	Rules	Reference path
REGION	removal_volume	10303-522		<pre> removal_volume &lt;= {feature_definition =&gt;   instantiated_feature} feature_definition &lt;= characterized_object                     </pre>
feature_placement	axis2_placement_3d	10303-42		<pre> characterized_definition = characterized_object characterized_definition &lt;- property_definition.definition { property_definition =&gt;   product_definition_shape } property_definition &lt;- property_definition_representation.definition { property_definition_representation =&gt;   shape_definition_representation } property_definition_representation property_definition_representation.used_representation -&gt; {representation =&gt;   shape_representation =&gt;   shape_representation_with_parameters} representation representation.items[i] -&gt; {representation_item.name = 'orientation'? } representation_item =&gt; geometric_representation_item =&gt;   placement =&gt;   axis2_placement_3d                     </pre>

**Table 4 — Mapping table for manufacturing features UoF (continued)**

Application element	AIM element	Source	Rules	Reference path
REGION_PROJECTION	shape_representation	10303-41		<pre> shape_representation &lt;=   representation &lt;-   property_definition.used_representation   property_definition_representation   { property_definition_representation =&gt;   shape_definition_representation }   property_definition_representation.definition -&gt;   property_definition   property_definition.definition -&gt;   characterized_definition   characterized_definition = shape_definition   shape_definition   shape_definition = shape_aspect   { shape_aspect.description = 'volume shape' }   shape_aspect &lt;-   shape_aspect.relationship.relatng_shape_aspect   { shape_aspect_relationship =&gt;   shape_defining_relationship }   { shape_aspect_relationship.description = 'volume shape usage' }   shape_aspect_relationship   shape_aspect_relationship.related_shape_aspect -&gt;   shape_aspect   { shape_aspect.description = 'shape volume occurrence' }   shape_aspect.of_shape -&gt;   product_definition_shape &lt;=   property_definition   property_definition.definition -&gt;   characterized_definition   characterized_definition = characterized_object   characterized_object =&gt;   removal_volume                     </pre>

**Table 4 — Mapping table for manufacturing features UoF (continued)**

Application element	AIM element	Source	Rules	Reference path
proj_curve	surface_of_linear_extrusion.- swept_curve	10303-42		shape_representation <= representation representation.items[i] -> representation_item=> geometric_representation_item=> surface=> swept_surface {swept_surface => surface_of_linear_extrusion} swept_surface.swept_curve
proj_dir	vector.orientation	10303-42		shape_representation <= representation representation.items[i] -> representation_item=> surface_of_linear_extrusion surface_of_linear_extrusion.axis -> vector vector.orientation
depth	vector.magnitude	10303-42		shape_representation <= representation representation.items[i] -> representation_item=> surface_of_linear_extrusion surface_of_linear_extrusion.axis -> vector vector.magnitude

**Table 4 — Mapping table for manufacturing features UoF (continued)**

Application element	AIM element	Source	Rules	Reference path
REGION_SURFACE_LIST	geometric_set	10303-507		<pre> geometric_set &lt;= representation_item &lt;- representation.items[i] {representation =&gt; geometrically_bounded_surface_shape_representation } representation &lt;- property_definition_representation.used_representation property_definition_representation { property_definition_representation =&gt; shape_definition_representation } property_definition_representation.definition -&gt; property_definition property_definition.definition -&gt; characterized_definition characterized_definition = shape_definition shape_definition shape_definition = shape_aspect { shape_aspect.description = 'volume shape' } shape_aspect &lt;- shape_aspect.relationship.relationing_shape_aspect { shape_aspect.relationship =&gt; shape_defining_relationship } { shape_aspect.relationship.description = 'volume shape usage' } shape_aspect.relationship shape_aspect.relationship.related_shape_aspect -&gt; shape_aspect { shape_aspect.description = 'shape volume occurrence' } shape_aspect.of_shape -&gt; product_definition_shape &lt;= property_definition property_definition.definition -&gt; characterized_definition characterized_definition = characterized_object characterized_object =&gt; removal_volume                     </pre>



**Table 4 — Mapping table for manufacturing features UoF (continued)**

Application element	AIM element	Source	Rules	Reference path
region_surface_list to bounded_surface (as surface_list)	bounded_surface	10303-42		geometric_set geometric_set.elements[i] -> geometric_set_select geometric_set_select = surface surface => bounded_surface
REPLICATE_FEATURE	replicate_feature			replicate_feature <= {feature_definition <= instanced_feature} feature_definition <= characterized_object
replicate_feature to twoSD_manufacturing_feature (as replicate_base_feature)	PATH			replicate_feature <= feature_definition => instanced_feature <= shape_aspect <- shape_aspect.relationship.relatng_shape_aspect {shape_aspect_relationship.name = 'pattern basis'} {shape_aspect_relationship => feature_component_relationship} shape_aspect_relationship shape_aspect_relationship.related_shape_aspect -> shape_aspect => instanced_feature
ROUND_HOLE	round_hole	10303-522		round_hole <= {feature_definition => instanced_feature} feature_definition <= characterized_object

**Table 4 — Mapping table for manufacturing features UoF (continued)**

Application element	AIM element	Source	Rules	Reference path
diameter	length_measure_with_unit	10303-41		<pre> round_hole &lt;= feature_definition &lt;= characterized_object characterized_definition = characterized_object characterized_definition &lt;- property_definition.definition property_definition =&gt; product_definition_shape &lt;- shape_aspect.of_shape {shape_aspect.description = 'diameter occurrence'} shape_aspect &lt;- shape_aspect.related_shape_aspect {shape_aspect.relationship =&gt; shape_defining_relationship} {shape_aspect.relationship.name = 'diameter'} {shape_aspect.relationship.description = 'profile usage'} shape_aspect.relationship shape_aspect.relationship.relatng_shape_aspect -&gt; shape_aspect =&gt; circular_closed_profile                     </pre> <p>NOTE See mapping for CIRCULAR_CLOSED_PROFILE.- diameter for the path from here to diameter measure</p>

**Table 4 — Mapping table for manufacturing features UoF (continued)**

Application element	AIM element	Source	Rules	Reference path
<p>round_hole to taper_select (as change_in_diameter)</p> <p>#1: as angle_taper</p> <p>#2: as diameter_taper</p>	<p>PATH</p>			<pre> round_hole &lt;= feature_definition &lt;= characterized_object characterized_definition = characterized_object characterized_definition &lt;- property_definition.definition property_definition =&gt; product_definition_shape &lt;- shape_aspect.of_shape {shape_aspect.description = 'change in diameter occurrence'} shape_aspect &lt;- shape_aspect &lt;- shape_aspect.related_shape_aspect {shape_aspect.relationship =&gt; feature_component_relationship} {shape_aspect.relationship.description = 'taper usage'} shape_aspect.relationship shape_aspect.relationship.relatng_shape_aspect -&gt; { #1: (shape_aspect.description = 'angle taper') #2: (shape_aspect.description = 'diameter taper') } shape_aspect =&gt; taper                     </pre>

**Table 4 — Mapping table for manufacturing features UoF (continued)**

Application element	AIM element	Source	Rules	Reference path
<p>round_hole to hole_bottom_condition (as bottom_condition)</p>	<p>PATH</p>			<pre> round_hole &lt;= feature_definition &lt;= characterized_object characterized_definition = characterized_object characterized_definition &lt;- property_definition.definition property_definition =&gt; product_definition_shape &lt;- shape_aspect.of_shape {shape_aspect.description = 'bottom condition occurrence'} shape_aspect &lt;- shape_aspect.related_shape_aspect {shape_aspect.relationship =&gt; feature_component_relationship} {shape_aspect.relationship.description = 'hole bottom usage'} shape_aspect.relationship shape_aspect.relationship.relatng_shape_aspect -&gt; {(shape_aspect.description = 'conical') (shape_aspect.description = 'flat')} (shape_aspect.description = 'flat with radius') (shape_aspect.description = 'flat with taper') (shape_aspect.description = 'spherical') (shape_aspect.description = 'through')}} shape_aspect =&gt; hole_bottom                     </pre>

**Table 4 — Mapping table for manufacturing features UoF (continued)**

Application element	AIM element	Source	Rules	Reference path
bottom_at_path_end  See NOTE 12, preferred mapping  #1: if value is true  #2: if value is false	shape_aspect_relationship.name	10303-41		<pre> round_hole &lt;= feature_definition &lt;= characterized_object characterized_definition = characterized_object characterized_definition &lt;- property_definition.definition property_definition =&gt; product_definition_shape &lt;- shape_aspect.of_shape {shape_aspect.description = 'bottom condition occurrence'} shape_aspect &lt;- shape_aspect_relationship.related_shape_aspect {shape_aspect_relationship =&gt; feature_component_relationship} shape_aspect_relationship shape_aspect_relationship.name { #1: (shape_aspect_relationship.name = 'hole depth end') #2: (shape_aspect_relationship.name = 'hole depth start') }</pre>

**Table 4 — Mapping table for manufacturing features UoF (continued)**

Application element	AIM element	Source	Rules	Reference path
<p>bottom_at_path_end</p> <p>See NOTE 12, alternate mapping based on observed AP 224 usage</p> <p>#1: if value is true</p> <p>#2: if value is false</p>	<p>descriptive_representation_item.-description</p>	<p>10303-45</p>		<pre> round_hole &lt;=   characterized_object   characterized_definition = characterized_object   characterized_definition &lt;-   property_definition.definition   property_definition =&gt;   product_definition_shape &lt;-   shape_aspect.of_shape   shape_aspect.description = 'bottom condition occurrence'   shape_aspect &lt;-   shape_aspect &lt;-   shape_aspect_relationship =&gt; feature_component_relationship   shape_aspect_relationship   shape_aspect_relationship.relatng_shape_aspect -&gt;   shape_aspect   {shape_aspect =&gt; hole_bottom}   shape_definition = shape_aspect   shape_definition   characterized_definition = shape_definition   characterized_definition &lt;-   property_definition.definition   property_definition &lt;-   property_definition.definition   property_definition_representation.definition   property_definition_representation   property_definition_representation.used_representation -&gt;   {representation =&gt; shape_representation_with_parameters}   representation   representation.items[i] -&gt;   {representation_item.name = 'blind bottom orientation'}   representation_item =&gt;   descriptive_representation_item   descriptive_representation_item.description   {#1: (descriptive_representation_item.description = \   'hole depth end'   #2: (descriptive_representation_item.description = \   'hole depth start')}                     </pre>

**Table 4 — Mapping table for manufacturing features UoF (continued)**

Application element	AIM element	Source	Rules	Reference path
round_hole to linear_path (as course_of_travel)	PATH			<pre> round_hole &lt;= feature_definition &lt;= characterized_object characterized_definition = characterized_object characterized_definition &lt;- property_definition.definition property_definition =&gt; product_definition_shape &lt;- shape_aspect.of_shape {shape_aspect.description = 'hole depth occurrence'} shape_aspect &lt;- shape_aspect.related_shape_aspect {shape_aspect.relationship =&gt; shape_defining_relationship} {shape_aspect.relationship.name = 'hole depth'} {shape_aspect.relationship.description = \ 'path feature component usage'} shape_aspect.relationship shape_aspect.relationship.relatng_shape_aspect -&gt; {shape_aspect.description = 'linear'} shape_aspect =&gt; path_feature_component                     </pre>
ROUNDED_END	rounded_end	10303-522		<pre> rounded_end &lt;= {feature_definition =&gt; instanced_feature} feature_definition &lt;= characterized_object                     </pre>

**Table 4 — Mapping table for manufacturing features UoF (continued)**

Application element	AIM element	Source	Rules	Reference path
rounded_end to linear_path (as course_of_travel)	PATH			<pre> rounded_end &lt;= feature_definition &lt;= characterized_object characterized_definition = characterized_object characterized_definition &lt;- property_definition.definition property_definition =&gt; product_definition_shape &lt;- shape_aspect.of_shape {shape_aspect.description = 'course of travel occurrence'} shape_aspect &lt;- shape_aspect.related_shape_aspect {shape_aspect.relationship =&gt; shape_defining_relationship} {shape_aspect.relationship.description = \ 'path feature component usage'} shape_aspect.relationship shape_aspect.relationship.relatng_shape_aspect -&gt; {shape_aspect.description = 'linear'} shape_aspect =&gt; path_feature_component                     </pre>



**Table 4 — Mapping table for manufacturing features UoF (continued)**

Application element	AIM element	Source	Rules	Reference path
rounded_end to partial_circular_profile (as partial_circular_boundary)	PATH			<pre> rounded_end &lt;= feature_definition &lt;= characterized_object characterized_definition = characterized_object characterized_definition &lt;- property_definition.definition property_definition =&gt; product_definition_shape &lt;- shape_aspect.of_shape {shape_aspect.description = 'partial circular boundary occurrence'} shape_aspect &lt;- shape_aspect.related_shape_aspect {shape_aspect.relationship =&gt; shape_defining_relationship} {shape_aspect.relationship.description = 'profile usage'} shape_aspect.relationship shape_aspect.relationship.relatng_shape_aspect -&gt; shape_aspect =&gt; partial_circular_profile </pre>
ROUNDED_U_PROFILE	rounded_u_profile	10303-522		<pre> rounded_u_profile &lt;= shape_aspect </pre>

**Table 4 — Mapping table for manufacturing features UoF (continued)**

Application element	AIM element	Source	Rules	Reference path
width	length_measure_with_unit	10303-41		<pre> rounded_u_profile &lt;=   shape_aspect   shape_definition = shape_aspect   shape_definition characterized_definition = shape_definition characterized_definition &lt;-   property_definition.definition   property_definition &lt;-   property_definition_representation.definition   { property_definition_representation =&gt;   shape_definition_representation }   property_definition_representation property_definition_representation.used_representation -&gt;   {representation =&gt;   shape_representation =&gt;   shape_representation_with_parameters}   representation   representation.items[j] -&gt;   {representation_item.name = 'width'}   representation_item =&gt;   measure_representation_item &lt;=   measure_with_unit =&gt;   length_measure_with_unit                     </pre>

**Table 4 — Mapping table for manufacturing features UoF (continued)**

Application element	AIM element	Source	Rules	Reference path
depth	length_measure_with_unit	10303-41		<pre> rounded_u_profile &lt;=   shape_aspect   shape_definition = shape_aspect   shape_definition characterized_definition = shape_definition characterized_definition &lt;-   property_definition.definition   property_definition &lt;-   property_definition_representation.definition   { property_definition_representation =&gt;   shape_definition_representation }   property_definition_representation property_definition_representation.used_representation -&gt;   {representation =&gt;   shape_representation =&gt;   shape_representation_with_parameters}   representation   representation.items[i] -&gt;   {representation_item.name = 'depth'}   representation_item =&gt;   measure_representation_item &lt;=   measure_with_unit =&gt;   length_measure_with_unit </pre>
SHAPE_PROFILE	outside_profile	10303-522		<pre> outside_profile &lt;=   {feature_definition =&gt;   instantiated_feature}   feature_definition &lt;=   characterized_object </pre>

**Table 4 — Mapping table for manufacturing features UoF (continued)**

Application element	AIM element	Source	Rules	Reference path
shape_profile to profile_select (as floor_condition) #1: as profile_floor #2: as through_profile_floor	PATH			<pre> outside_profile &lt;= feature_definition &lt;= characterized_object characterized_definition = characterized_object characterized_definition &lt;- property_definition.definition property_definition =&gt; product_definition_shape &lt;- shape_aspect.of_shape {{shape_aspect.description = 'complex boundary occurrence'} (shape_aspect.description = 'partial circular boundary occurrence')} (shape_aspect.description = 'closed circular boundary occurrence')} (shape_aspect.description = \ 'open rectangular boundary occurrence') (shape_aspect.description = \ 'closed rectangular boundary occurrence')} shape_aspect &lt;- shape_aspect.related_shape_aspect {shape_aspect.relationship =&gt; feature_component_relationship} {shape_aspect.relationship.description = 'profile floor usage'} shape_aspect.relationship { #1: (shape_aspect.description = 'planar') #1: (shape_aspect.description = 'complex') #2: (shape_aspect.description = 'through') } shape_aspect =&gt; profile_floor                     </pre>

**Table 4 — Mapping table for manufacturing features UoF (continued)**

Application element	AIM element	Source	Rules	Reference path
removal_direction	direction	10303-42		<pre> outside_profile &lt;= feature_definition &lt;= characterized_object characterized_definition = characterized_object characterized_definition &lt;- property_definition.definition property_definition &lt;- {property_definition =&gt; product_definition_shape &lt;- shape_aspect.of_shape shape_aspect (shape_aspect.description = 'complex boundary occurrence') (shape_aspect.description = 'partial circular boundary occurrence') (shape_aspect.description = 'closed circular boundary occurrence') (shape_aspect.description = \ 'open rectangular boundary occurrence') (shape_aspect.description = \ 'closed rectangular boundary occurrence') } property_definition.definition property_definition_representation property_definition_representation.used_representation -&gt; representation {representation.name = 'removal direction'} { representation =&gt; shape_representation=&gt; direction_shape_representation } representation.items[i] -&gt; representation_item =&gt; geometric_representation_item =&gt; direction </pre>
SLOT	slot	10303-522		<pre> slot &lt;= {feature_definition =&gt; instance.feature } feature_definition &lt;= characterized_object </pre>

**Table 4 — Mapping table for manufacturing features UoF (continued)**

Application element	AIM element	Source	Rules	Reference path
slot to travel_path (as course_of_travel)	PATH			<pre>                     slot &lt;=                     feature_definition &lt;=                     characterized_object                     characterized_definition = characterized_object                     characterized_definition &lt;-                     property_definition.definition                     property_definition =&gt;                     product_definition_shape &lt;-                     shape_aspect.of_shape                     {shape_aspect.description = 'course of travel occurrence'}                     shape_aspect &lt;-                     shape_aspect.related_shape_aspect                     {shape_aspect.relationship =&gt;                     shape_defining_relationship}                     {shape_aspect.relationship.name = 'course of travel'}                     {shape_aspect.relationship.description = \                     'path feature component usage'}                     shape_aspect.relationship                     shape_aspect.relationship.relatng_shape_aspect -&gt;                     shape_aspect =&gt;                     path_feature_component                     </pre>

**Table 4 — Mapping table for manufacturing features UoF (continued)**

Application element	AIM element	Source	Rules	Reference path
slot to open_profile (as swept_shape)	PATH			<pre> slot &lt;= feature_definition &lt;= characterized_object characterized_definition = characterized_object characterized_definition &lt;- property_definition.definition property_definition =&gt; product_definition_shape &lt;- shape_aspect.of_shape {shape_aspect.description = 'swept shape occurrence'} shape_aspect &lt;- shape_aspect.relationship.related_shape_aspect {shape_aspect.relationship =&gt; shape_defining_relationship} {shape_aspect.relationship.description = 'profile usage'} shape_aspect.relationship shape_aspect.relationship.relatng_shape_aspect -&gt; shape_aspect =&gt; (open_path_profile) (partial_circular_profile) (rounded_u_profile) (square_u_profile) (tee_profile) (vee_profile)                     </pre>

**Table 4 — Mapping table for manufacturing features UoF (continued)**

Application element	AIM element	Source	Rules	Reference path
slot to slot_end_type (as end_conditions)	PATH			<pre> slot &lt;= feature_definition &lt;= characterized_object characterized_definition = characterized_object characterized_definition &lt;- property_definition.definition property_definition =&gt; product_definition_shape &lt;- shape_aspect.of_shape {shape_aspect.description = 'end condition occurrence'} shape_aspect &lt;- shape_aspect.related_shape_aspect {shape_aspect.relationship =&gt; feature_component_relationship} {shape_aspect.relationship.description = 'slot end usage'} {(shape_aspect.relationship.name = 'course of travel start') (shape_aspect.relationship.name = 'course of travel end')} shape_aspect.relationship shape_aspect.relationship.relatng_shape_aspect -&gt; shape_aspect =&gt; slot_end                     </pre>
SLOT_END_TYPE	slot_end	10303-522		<pre> slot_end &lt;= shape_aspect {shape_aspect.of_shape -&gt; product_definition_shape &lt;= property_definition property_definition.definition -&gt; characterized_definition characterized_definition = characterized_object characterized_object =&gt; feature_component_definition}                     </pre>
SPECIFICATION	document	10303-41		



**Table 4 — Mapping table for manufacturing features UoF (continued)**

Application element	AIM element	Source	Rules	Reference path
specification to specification_usage_constraint (as constraint)	PATH			document <- document_usage_constraint.source document_usage_constraint
specification_id	document.id	10303-41		
specification_description	document.description	10303-41		
specification_class	document_with_class.class	10303-41		document=> document_with_class document_with_class.class
SPECIFICATION_USAGE_- CONSTRAINT	document_usage_constraint	10303-41		
element	document_usage_constraint.- subject_element	10303-41		
class_id	document_usage_constraint.- subject_element_value	10303-41		
SPHERICAL_CAP	spherical_cap	10303-522		spherical_cap <= {feature_definition => instanced_feature} feature_definition <= characterized_object

**Table 4 — Mapping table for manufacturing features UoF (continued)**

Application element	AIM element	Source	Rules	Reference path
internal_angle	plane_angle_measure_with_unit	10303-41		<pre> spherical_cap &lt;= feature_definition &lt;= characterized_object characterized_definition = characterized_object characterized_definition &lt;- property_definition.definition { property_definition =&gt; product_definition_shape } property_definition &lt;- property_definition_representation.definition { property_definition_representation =&gt; shape_definition_representation } property_definition_representation property_definition_representation.used_representation -&gt; {representation =&gt; shape_representation =&gt; shape_representation_with_parameters} representation representation.items[i] -&gt; {representation_item.name = 'internal_angle'} representation_item =&gt; measure_representation_item &lt;= measure_with_unit =&gt; plane_angle_measure_with_unit                     </pre>

**Table 4 — Mapping table for manufacturing features UoF (continued)**

Application element	AIM element	Source	Rules	Reference path
radius	length_measure_with_unit	10303-41		<pre> spherical_cap &lt;= feature_definition &lt;= characterized_object characterized_definition = characterized_object characterized_definition &lt;- property_definition.definition { property_definition =&gt; product_definition_shape } property_definition &lt;- property_definition.definition { property_definition_representation =&gt; shape_definition_representation } property_definition_representation property_definition_representation.used_representation -&gt; {representation =&gt; shape_representation =&gt; shape_representation_with_parameters} representation representation.items[i] -&gt; {representation_item.name = 'radius' } representation_item =&gt; measure_representation_item &lt;= measure_with_unit =&gt; length_measure_with_unit </pre>
SPHERICAL_HOLE_BOTTOM	hole_bottom	10303-522		<pre> hole_bottom &lt;= shape_aspect { shape_aspect.description = 'spherical' } </pre>

**Table 4 — Mapping table for manufacturing features UoF (continued)**

Application element	AIM element	Source	Rules	Reference path
radius	length_measure_with_unit	10303-41		hole_bottom <= shape_aspect shape_definition = shape_aspect shape_definition characterized_definition = shape_definition characterized_definition <= property_definition.definition property_definition <= property_definition_representation.definition { property_definition_representation => shape_definition_representation } property_definition_representation property_definition_representation.used_representation -> {representation => shape_representation => shape_representation_with_parameters} representation representation.items[i] -> {representation_item.name = 'radius'} representation_item => measure_representation_item <= measure_with_unit => length_measure_with_unit
SQUARE_U_PROFILE	square_u_profile	10303-522		square_u_profile <= shape_aspect

**Table 4 — Mapping table for manufacturing features UoF (continued)**

Application element	AIM element	Source	Rules	Reference path
width	length_measure_with_unit	10303-41		<pre> square_u_profile &lt;=   shape_aspect   shape_definition = shape_aspect   shape_definition characterized_definition = shape_definition characterized_definition &lt;-   property_definition.definition   property_definition &lt;-   property_definition_representation.definition { property_definition_representation =&gt;   shape_definition_representation } property_definition_representation property_definition_representation.used_representation -&gt;   {representation =&gt;   shape_representation =&gt;   shape_representation_with_parameters}   representation   representation.items[i] -&gt;   {representation_item.name = 'width'}   representation_item =&gt;   measure_representation_item &lt;=   measure_with_unit =&gt;   length_measure_with_unit                     </pre>

**Table 4 — Mapping table for manufacturing features UoF (continued)**

Application element	AIM element	Source	Rules	Reference path
first_radius	length_measure_with_unit	10303-41		<pre> square_u_profile &lt;=   shape_aspect   shape_definition = shape_aspect   shape_definition characterized_definition = shape_definition characterized_definition &lt;-   property_definition.definition   property_definition &lt;-   property_definition_representation.definition   { property_definition_representation =&gt;   shape_definition_representation }   property_definition_representation property_definition_representation.used_representation -&gt;   {representation =&gt;   shape_representation =&gt;   shape_representation_with_parameters}   representation   representation.items[i] -&gt;   {representation_item.name = 'first radius'}   representation_item =&gt;   measure_representation_item &lt;=   measure_with_unit =&gt;   length_measure_with_unit </pre>

**Table 4 — Mapping table for manufacturing features UoF (continued)**

Application element	AIM element	Source	Rules	Reference path
first_angle	plane_angle_measure_with_unit	10303-41		<pre> square_u_profile &lt;=   shape_aspect   shape_definition = shape_aspect   shape_definition characterized_definition = shape_definition characterized_definition &lt;-   property_definition.definition   property_definition &lt;-   property_definition_representation.definition { property_definition_representation =&gt;   shape_definition_representation } property_definition_representation property_definition_representation.used_representation -&gt;   {representation =&gt;   shape_representation =&gt;   shape_representation_with_parameters} representation representation.items[i] -&gt; {representation_item.name = 'first_angle'} representation_item =&gt; measure_representation_item &lt;= measure_with_unit =&gt; plane_angle_measure_with_unit                     </pre>

**Table 4 — Mapping table for manufacturing features UoF (continued)**

Application element	AIM element	Source	Rules	Reference path
second_radius	length_measure_with_unit	10303-41		<pre> square_u_profile &lt;=   shape_aspect   shape_definition = shape_aspect   shape_definition characterized_definition = shape_definition characterized_definition &lt;-   property_definition.definition   property_definition &lt;-   property_definition_representation.definition   { property_definition_representation =&gt;   shape_definition_representation }   property_definition_representation property_definition_representation.used_representation -&gt;   {representation =&gt;   shape_representation =&gt;   shape_representation_with_parameters}   representation   representation.items[i] -&gt;   {representation_item.name = 'second radius'}   representation_item =&gt;   measure_representation_item &lt;=   measure_with_unit =&gt;   length_measure_with_unit                     </pre>



**Table 4 — Mapping table for manufacturing features UoF (continued)**

Application element	AIM element	Source	Rules	Reference path
second_angle	plane_angle_measure_with_unit	10303-41		<pre> square_u_profile &lt;=   shape_aspect   shape_definition = shape_aspect   shape_definition characterized_definition = shape_definition characterized_definition &lt;-   property_definition.definition   property_definition &lt;-   property_definition_representation.definition   { property_definition_representation =&gt;   shape_definition_representation }   property_definition_representation property_definition_representation.used_representation -&gt;   {representation =&gt;   shape_representation =&gt;   shape_representation_with_parameters}   representation   representation.items[i] -&gt;   {representation_item.name = 'second_angle'}   representation_item =&gt;   measure_representation_item &lt;=   measure_with_unit =&gt;   plane_angle_measure_with_unit                     </pre>

**Table 4 — Mapping table for manufacturing features UoF (continued)**

Application element	AIM element	Source	Rules	Reference path
depth	length_measure_with_unit	10303-41		<pre> square_u_profile &lt;=   shape_aspect   shape_definition = shape_aspect   shape_definition characterized_definition = shape_definition characterized_definition &lt;-   property_definition.definition   property_definition &lt;-   property_definition_representation.definition   { property_definition_representation =&gt;   shape_definition_representation }   property_definition_representation property_definition_representation.used_representation -&gt;   {representation =&gt;   shape_representation =&gt;   shape_representation_with_parameters}   representation   representation.items[i] -&gt;   {representation_item.name = 'depth'}   representation_item =&gt;   measure_representation_item &lt;=   measure_with_unit =&gt;   length_measure_with_unit </pre>
STEP	step	10303-522		<pre> step &lt;=   {feature_definition =&gt;   instantiated_feature}   feature_definition &lt;=   characterized_object </pre>

**Table 4 — Mapping table for manufacturing features UoF (continued)**

Application element	AIM element	Source	Rules	Reference path
step to linear_path (as open_boundary)	PATH			<pre> step &lt;= feature_definition &lt;= characterized_object characterized_definition = characterized_object characterized_definition &lt;- property_definition.definition property_definition =&gt; product_definition_shape &lt;- shape_aspect.of_shape {shape_aspect.description = 'course of travel occurrence'} shape_aspect &lt;- shape_aspect.related_shape_aspect {shape_aspect.relationship =&gt; shape_defining_relationship} {shape_aspect.relationship.description = \ 'path feature component usage'} shape_aspect.relationship shape_aspect.relationship.relatng_shape_aspect -&gt; {shape_aspect.description = 'linear'} shape_aspect =&gt; path_feature_component                     </pre>

**Table 4 — Mapping table for manufacturing features UoF (continued)**

Application element	AIM element	Source	Rules	Reference path
step to vee_profile (as wall_boundary)	PATH			<pre> step &lt;= feature_definition &lt;= characterized_object characterized_definition = characterized_object characterized_definition &lt;- property_definition.definition property_definition =&gt; product_definition_shape &lt;- shape_aspect.of_shape {shape_aspect.description = 'removal boundary occurrence'} shape_aspect &lt;- shape_aspect.related_shape_aspect {shape_aspect.relationship =&gt; shape_defining_relationship} {shape_aspect.relationship.description = 'profile usage'} shape_aspect.relationship shape_aspect.relationship.relatng_shape_aspect -&gt; shape_aspect =&gt; vee_profile                     </pre>

**Table 4 — Mapping table for manufacturing features UoF (continued)**

Application element	AIM element	Source	Rules	Reference path
step to boss (as its_boss)	PATH			<pre> step &lt;= feature_definition &lt;= characterized_object characterized_definition = characterized_object characterized_definition &lt;- property_definition.definition property_definition =&gt; product_definition_shape &lt;- shape_aspect.of_shape {shape_aspect =&gt; composite_shape_aspect} shape_aspect &lt;- shape_aspect &lt;- shape_aspect.relationship.relatng_shape_aspect shape_aspect.relationship.description = 'uncut volume' {shape_aspect.relationship=&gt; feature_component_relationship} shape_aspect_relationship shape_aspect_relationship.related_shape_aspect-&gt; shape_aspect =&gt; instanced_feature &lt;= feature_definition =&gt; boss                     </pre>
SURFACE_TEXTURE_PARAMETER	surface_texture_representation	10303-238		<pre> surface_texture_representation &lt;= representation                     </pre>
surface_texture_parameter to parameter_value (as its_value)	measure_representation_item	10303-45		<pre> surface_texture_representation &lt;= representation representation.items[i] -&gt; representation_item =&gt; measure_representation_item                     </pre>

**Table 4 — Mapping table for manufacturing features UoF (continued)**

Application element	AIM element	Source	Rules	Reference path
parameter_name	representation_item.name	10303-43		<pre> surface_texture_representation &lt;=   representation   representation.items[i] -&gt;   { representation_item =&gt;     measure_representation_item }     representation_item }     representation_item.name                     </pre>
measuring_method	descriptive_representation_item.-description	10303-45		<pre> surface_texture_representation &lt;=   representation   representation.items[i] -&gt;   representation_item =&gt;   {representation_item.name = 'measuring method' }     descriptive_representation_item     {(descriptive_representation_item.description       (descriptive_representation_item.description = 'ISO 4287')       (descriptive_representation_item.description = 'ISO 12085')       (descriptive_representation_item.description = 'ISO 13565'))}                     </pre>
parameter_index	representation_item.name	10303-43		<pre> surface_texture_representation &lt;=   representation   representation.items[i] -&gt;   { representation_item =&gt;     measure_representation_item }     representation_item     representation_item.name                     </pre> <p style="text-align: center;">See NOTE 14</p>
surface_texture_parameter to machined_surface (as applied_surfaces)	PATH			<pre> surface_texture_representation &lt;=   representation &lt;-   property_definition_representation.used_representation   property_definition_representation   property_definition_representation.definition -&gt;   property_definition                     </pre>

**Table 4 — Mapping table for manufacturing features UoF (continued)**

Application element	AIM element	Source	Rules	Reference path
TEE_PROFILE	tee_profile	10303-522		tee_profile <= shape_aspect
first_angle	plane_angle_measure_with_unit	10303-41		tee_profile <= shape_aspect shape_definition = shape_aspect shape_definition characterized_definition = shape_definition characterized_definition <= property_definition.definition property_definition <= property_definition <= property_definition_representation.definition { property_definition_representation => shape_definition_representation } property_definition_representation property_definition_representation.used_representation -> {representation => shape_representation => shape_representation_with_parameters} representation representation.items[j] -> representation_item.name = 'first angle'} representation_item => measure_representation_item <= measure_with_unit => plane_angle_measure_with_unit

**Table 4 — Mapping table for manufacturing features UoF (continued)**

Application element	AIM element	Source	Rules	Reference path
second_angle	plane_angle_measure_with_unit	10303-41		<pre> tee_profile &lt;=   shape_aspect   shape_definition = shape_aspect   shape_definition characterized_definition = shape_definition characterized_definition &lt;-   property_definition.definition   property_definition &lt;-   property_definition_representation.definition   { property_definition_representation =&gt;   shape_definition_representation }   property_definition_representation property_definition_representation.used_representation -&gt;   {representation =&gt;   shape_representation =&gt;   shape_representation_with_parameters}   representation   representation.items[i] -&gt;   {representation_item.name = 'second_angle'}   representation_item =&gt;   measure_representation_item &lt;=   measure_with_unit =&gt;   plane_angle_measure_with_unit                     </pre>



**Table 4 — Mapping table for manufacturing features UoF (continued)**

Application element	AIM element	Source	Rules	Reference path
cross_bar_width	length_measure_with_unit	10303-41		<pre> tee_profile &lt;=   shape_aspect   shape_definition = shape_aspect   shape_definition characterized_definition = shape_definition characterized_definition &lt;-   property_definition.definition   property_definition &lt;-   property_definition_representation.definition   { property_definition_representation =&gt;   shape_definition_representation }   property_definition_representation property_definition_representation.used_representation -&gt;   {representation =&gt;   shape_representation =&gt;   shape_representation_with_parameters}   representation   representation.items[i] -&gt;   {representation_item.name = 'cross bar width'}   representation_item =&gt;   measure_representation_item &lt;=   measure_with_unit =&gt;   length_measure_with_unit </pre>

**Table 4 — Mapping table for manufacturing features UoF (continued)**

Application element	AIM element	Source	Rules	Reference path
cross_bar_depth	length_measure_with_unit	10303-41		<pre> tee_profile &lt;=   shape_aspect   shape_definition = shape_aspect   shape_definition characterized_definition = shape_definition characterized_definition &lt;-   property_definition.definition   property_definition &lt;-   property_definition_representation.definition   { property_definition_representation =&gt;   shape_definition_representation }   property_definition_representation property_definition_representation.used_representation -&gt;   {representation =&gt;   shape_representation =&gt;   shape_representation_with_parameters}   representation   representation.items[i] -&gt;   {representation_item.name = 'cross bar depth'}   representation_item =&gt;   measure_representation_item &lt;=   measure_with_unit =&gt;   length_measure_with_unit                     </pre>

**Table 4 — Mapping table for manufacturing features UoF (continued)**

Application element	AIM element	Source	Rules	Reference path
radius	length_measure_with_unit	10303-41		<pre> tee_profile &lt;=   shape_aspect   shape_definition = shape_aspect   shape_definition characterized_definition = shape_definition characterized_definition &lt;-   property_definition.definition   property_definition &lt;-   property_definition_representation.definition { property_definition_representation =&gt;   shape_definition_representation } property_definition_representation property_definition_representation.used_representation -&gt;   {representation =&gt;   shape_representation =&gt;   shape_representation_with_parameters} representation representation.items[j] -&gt; {representation_item.name = 'radius'} representation_item =&gt; measure_representation_item &lt;= measure_with_unit =&gt; length_measure_with_unit                     </pre>

**Table 4 — Mapping table for manufacturing features UoF (continued)**

Application element	AIM element	Source	Rules	Reference path
width	length_measure_with_unit	10303-41		<pre> tee_profile &lt;=   shape_aspect   shape_definition = shape_aspect   shape_definition characterized_definition = shape_definition characterized_definition &lt;-   property_definition.definition   property_definition &lt;-   property_definition_representation.definition { property_definition_representation =&gt;   shape_definition_representation } property_definition_representation property_definition_representation.used_representation -&gt;   {representation =&gt;   shape_representation =&gt;   shape_representation_with_parameters} representation representation.items[i] -&gt; {representation_item.name = 'width'} representation_item =&gt; measure_representation_item &lt;= measure_with_unit =&gt; length_measure_with_unit                     </pre>

**Table 4 — Mapping table for manufacturing features UoF (continued)**

Application element	AIM element	Source	Rules	Reference path
first_offset	length_measure_with_unit	10303-41		<pre> tee_profile &lt;=   shape_aspect   shape_definition = shape_aspect   shape_definition characterized_definition = shape_definition characterized_definition &lt;-   property_definition.definition   property_definition &lt;-   property_definition_representation.definition { property_definition_representation =&gt;   shape_definition_representation } property_definition_representation property_definition_representation.used_representation -&gt;   {representation =&gt;   shape_representation =&gt;   shape_representation_with_parameters} representation representation.items[j] -&gt; {representation_item.name = 'first_offset'} representation_item =&gt; measure_representation_item &lt;= measure_with_unit =&gt; length_measure_with_unit                     </pre>

**Table 4 — Mapping table for manufacturing features UoF (continued)**

Application element	AIM element	Source	Rules	Reference path
second_offset	length_measure_with_unit	10303-41		<pre> tee_profile &lt;=   shape_aspect   shape_definition = shape_aspect   shape_definition   characterized_definition = shape_definition   characterized_definition &lt;-   property_definition.definition   property_definition &lt;-   property_definition_representation.definition   { property_definition_representation =&gt;   shape_definition_representation }   property_definition_representation   property_definition_representation.used_representation -&gt;   {representation =&gt;   shape_representation =&gt;   shape_representation_with_parameters}   representation   representation.items[i] -&gt;   representation_item.name = 'second_offset'}   representation_item =&gt;   measure_representation_item &lt;=   measure_with_unit =&gt;   length_measure_with_unit                     </pre>
THREAD	(thread) (externally_defined_feature_ - definition)	10303-522 10303-522		<pre> (thread &lt;=   {feature_definition =&gt;   instantiated_feature}   feature_definition &lt;=   characterized_object)   (externally_defined_feature_definition &lt;=   [externally_defined_item]   [{feature_definition =&gt;   instantiated_feature}   feature_definition &lt;=   characterized_object   {characterized_object.description = 'thread'}])                     </pre>

**Table 4 — Mapping table for manufacturing features UoF (continued)**

Application element	AIM element	Source	Rules	Reference path
thread to partial_area_definition (as partial_profile)	PATH			<pre> (thread &lt;=) (externally_defined_feature_definition &lt;=) feature_definition &lt;= characterized_object characterized_definition = characterized_object characterized_definition &lt;- property_definition.definition property_definition =&gt; product_definition_shape &lt;- shape_aspect.of_shape shape_aspect &lt;- shape_aspect.related_shape_aspect shape_aspect.relationship.description = 'applied area usage' {shape_aspect.relationship =&gt; shape_defining_relationship} shape_aspect.relationship shape_aspect.relationship.relatng_shape_aspect -&gt; shape_aspect =&gt; applied_area                     </pre>

**Table 4 — Mapping table for manufacturing features UoF (continued)**

Application element	AIM element	Source	Rules	Reference path
thread to machining_feature (as applied_shape)	PATH			<pre> (thread &lt;=) (externally_defined_feature_definition &lt;=) feature_definition &lt;= characterized_object characterized_definition = characterized_object characterized_definition &lt;- property_definition.definition property_definition =&gt; product_definition_shape &lt;- shape_aspect.of_shape shape_aspect &lt;- shape_aspect.relationship.related_shape_aspect shape_aspect.relationship.description = 'applied shape' } { shape_aspect.relationship =&gt; shape_defining_relationship } shape_aspect.relationship shape_aspect.relationship.relatng_shape_aspect -&gt; shape_aspect =&gt; instanced_feature                     </pre>



**Table 4 — Mapping table for manufacturing features UoF (continued)**

Application element	AIM element	Source	Rules	Reference path
inner_or_outer_thread	descriptive_representation_- item.description	10303-45		<pre> (thread &lt;=&gt;) (externally_defined_feature_definition &lt;=&gt;) feature_definition &lt;=&gt; characterized_object characterized_definition = characterized_object characterized_definition &lt;- property_definition.definition { property_definition =&gt; product_definition_shape } property_definition &lt;- property_definition_representation.definition { property_definition_representation =&gt; shape_definition_representation } property_definition_representation property_definition_representation.used_representation -&gt; {representation =&gt; shape_representation =&gt; shape_representation_with_parameters} representation representation.items[i] -&gt; {representation_item.name = 'thread side'} representation_item =&gt; descriptive_representation_item descriptive_representation_item.description {(descriptive_representation_item.description = 'internal') (descriptive_representation_item.description = 'external')}}                     </pre>

**Table 4 — Mapping table for manufacturing features UoF (continued)**

Application element	AIM element	Source	Rules	Reference path
qualifier	descriptive_representation_item	10303-45		<pre> (thread &lt;=) (externally_defined_feature_definition &lt;=) feature_definition &lt;= characterized_object characterized_definition = characterized_object characterized_definition &lt;- property_definition.definition { property_definition =&gt; product_definition_shape } property_definition &lt;- property_definition_representation.definition { property_definition_representation =&gt; shape_definition_representation } property_definition_representation { property_definition_representation.used_representation -&gt; {representation =&gt; shape_representation =&gt; shape_representation_with_parameters} representation representation.items[i] -&gt; {representation_item.name = 'qualifier'} representation_item =&gt; descriptive_representation_item                     </pre>

**Table 4 — Mapping table for manufacturing features UoF (continued)**

Application element	AIM element	Source	Rules	Reference path
fit_class	descriptive_representation_item	10303-45		<pre> (thread &lt;=) (externally_defined_feature_definition &lt;=) feature_definition &lt;= characterized_object characterized_definition = characterized_object characterized_definition &lt;- property_definition.definition { property_definition =&gt; product_definition_shape } property_definition &lt;- property_definition_representation.definition { property_definition_representation =&gt; shape_definition_representation } property_definition_representation { property_definition_representation.used_representation -&gt; {representation =&gt; shape_representation =&gt; shape_representation_with_parameters} representation representation.items[i] -&gt; {representation_item.name = 'fit class'} representation_item =&gt; descriptive_representation_item </pre>

**Table 4 — Mapping table for manufacturing features UoF (continued)**

Application element	AIM element	Source	Rules	Reference path
form	descriptive_representation_item	10303-45		<pre> (thread &lt;=) (externally_defined_feature_definition &lt;=) feature_definition &lt;= characterized_object characterized_definition = characterized_object characterized_definition &lt;- property_definition.definition { property_definition =&gt; product_definition_shape } property_definition &lt;- property_definition_representation.definition { property_definition_representation =&gt; shape_definition_representation } property_definition_representation { property_definition_representation =&gt; shape_definition_representation } property_definition_representation.used_representation -&gt; {representation =&gt; shape_representation =&gt; shape_representation_with_parameters} representation representation.items[i] -&gt; {representation_item.name = 'form'} representation_item =&gt; descriptive_representation_item                     </pre>

**Table 4 — Mapping table for manufacturing features UoF (continued)**

Application element	AIM element	Source	Rules	Reference path
major_diameter	length_measure_with_unit	10303-41		<pre> (thread &lt;=) (externally_defined_feature_definition &lt;=) feature_definition &lt;= characterized_object characterized_definition = characterized_object characterized_definition &lt;- property_definition.definition { property_definition =&gt; product_definition_shape } property_definition &lt;- property_definition_representation.definition { property_definition_representation =&gt; shape_definition_representation } property_definition_representation property_definition_representation.used_representation -&gt; {representation =&gt; shape_representation =&gt; shape_representation_with_parameters} representation representation.items[i] -&gt; {representation_item.name = 'major diameter'} representation_item =&gt; measure_representation_item &lt;= measure_with_unit =&gt; length_measure_with_unit                     </pre>

**Table 4 — Mapping table for manufacturing features UoF (continued)**

Application element	AIM element	Source	Rules	Reference path
number_of_threads	ratio_measure_with_unit			<pre> (thread &lt;=) (externally_defined_feature_definition &lt;=) feature_definition &lt;= characterized_object characterized_definition = characterized_object characterized_definition &lt;- property_definition.definition { property_definition =&gt; product_definition_shape } property_definition &lt;- property_definition_representation.definition { property_definition_representation =&gt; shape_definition_representation } property_definition_representation property_definition_representation.used_representation -&gt; {representation =&gt; shape_representation =&gt; shape_representation_with_parameters} representation representation.items[i] -&gt; {representation_item.name = 'number of threads'} representation_item =&gt; measure_representation_item &lt;= measure_with_unit =&gt; ratio_measure_with_unit                     </pre>

**Table 4 — Mapping table for manufacturing features UoF (continued)**

Application element	AIM element	Source	Rules	Reference path
thread_hand	descriptive_representation_item.description	10303-45		<pre> (thread &lt;=&gt;) (externally_defined_feature_definition &lt;=&gt;) feature_definition &lt;=&gt; characterized_object characterized_definition = characterized_object characterized_definition &lt;- property_definition.definition { property_definition =&gt; product_definition_shape } property_definition &lt;- property_definition_representation.definition { property_definition_representation =&gt; shape_definition_representation } property_definition_representation property_definition_representation.used_representation -&gt; {representation =&gt; shape_representation =&gt; shape_representation_with_parameters} representation representation.items[i] -&gt; { representation_item.name = 'hand' } representation_item =&gt; descriptive_representation_item descriptive_representation_item.description {(descriptive_representation_item.description = 'left') (descriptive_representation_item.description = 'right')}                     </pre>

**Table 4 — Mapping table for manufacturing features UoF (continued)**

Application element	AIM element	Source	Rules	Reference path
THROUGH_BOTTOM_CONDITION	hole_bottom	10303-522		<pre> hole_bottom &lt;=   shape_aspect   { shape_aspect.description = 'through' }   { shape_aspect.of_shape -&gt;     product_definition_shape &lt;=       property_definition       property_definition.definition -&gt;         characterized_definition         characterized_definition = characterized_object         characterized_object =&gt;           feature_component_definition} </pre>
THROUGH_POCKET_BOTTOM_CONDITION	pocket_bottom	10303-522		<pre> pocket_bottom &lt;=   shape_aspect   { shape_aspect.description = 'through' } </pre>
THROUGH_PROFILE_FLOOR	profile_floor	10303-522		<pre> profile_floor &lt;=   shape_aspect   { shape_aspect.description = 'through' }   { shape_aspect.of_shape -&gt;     product_definition_shape &lt;=       property_definition       property_definition.definition -&gt;         characterized_definition         characterized_definition = characterized_object         characterized_object =&gt;           feature_component_definition} </pre>
TOOLPATH_FEATURE	instanced_feature	10303-522		<pre> instanced_feature &lt;=   feature_definition &lt;=     characterized_object     { characterized_object.description = 'toolpath' } </pre>



**Table 4 — Mapping table for manufacturing features UoF (continued)**

Application element	AIM element	Source	Rules	Reference path
TOPOLOGICAL_REGION	open_shell	10303-42		<pre> shell_based_surface_model.sbsm_boundary[1] shell_based_surface_model &lt;=   representation_item &lt;-   representation.items[i]   {representation =&gt;     manifold_surface_shape_representation }   representation &lt;-   property_definition.used_representation   property_definition_representation   { property_definition_representation =&gt;     shape_definition_representation }   property_definition_representation.definition -&gt;     property_definition   property_definition.definition -&gt;     characterized_definition   characterized_definition = shape_definition   shape_definition = shape_aspect   { shape_aspect.description = 'volume shape' }     shape_aspect &lt;-   shape_aspect.relationship.relatng_shape_aspect   { shape_aspect.relationship =&gt;     shape_defining_relationship }   { shape_aspect.relationship.description = 'volume shape usage' }     shape_aspect.relationship   shape_aspect.relationship.related_shape_aspect -&gt;     shape_aspect   { shape_aspect.description = 'shape volume occurrence' }     shape_aspect.of_shape -&gt;     product_definition_shape &lt;=     property_definition   property_definition.definition -&gt;     characterized_object =&gt;     removal_volume </pre>

**Table 4 — Mapping table for manufacturing features UoF (continued)**

Application element	AIM element	Source	Rules	Reference path
TRANSITION_FEATURE	transition_feature	10303-522		transition_feature <=> shape_aspect
transition_feature to machining_feature (as first_feature)	PATH		3, 7	transition_feature <=> shape_aspect shape_definition = shape_aspect shape_definition characterized_definition = shape_definition characterized_definition <= property_definition.definition property_definition => product_definition_shape <= shape_aspect.of_shape {shape_aspect => composite_shape_aspect} shape_aspect <= shape_aspect_relationship.relationing_shape_aspect { shape_aspect_relationship.name = 'first feature' } {shape_aspect_relationship=> feature_component_relationship} shape_aspect_relationship.related_shape_aspect-> shape_aspect => (instanced_feature) (transition_feature)

**Table 4 — Mapping table for manufacturing features UoF (continued)**

Application element	AIM element	Source	Rules	Reference path
transition_feature to machining_feature (as second_feature)	PATH		3, 7	<pre> transition_feature &lt;=   shape_aspect   shape_definition = shape_aspect   shape_definition   characterized_definition = shape_definition   characterized_definition &lt;-   property_definition.definition   property_definition =&gt;   product_definition_shape &lt;-   shape_aspect.of_shape   {shape_aspect =&gt;   composite_shape_aspect}   shape_aspect &lt;-   shape_aspect.relationship.relatng_shape_aspect   { shape_aspect.relationship.name = 'second feature' }   {shape_aspect.relationship=&gt;   feature_component_relationship}   shape_aspect.relationship.related_shape_aspect-&gt;   shape_aspect =&gt;   (instanced_feature)   (transition_feature)                     </pre>
TRAVEL_PATH	path_feature_component	10303-522		<pre> path_feature_component &lt;=   shape_aspect   {shape_aspect   shape_aspect.of_shape-&gt;   product_definition_shape &lt;=   property_definition   property_definition.definition-&gt;   characterized_definition   characterized_definition = characterized_object   characterized_object =&gt;   feature_component_definition}                     </pre>

**Table 4 — Mapping table for manufacturing features UoF (continued)**

Application element	AIM element	Source	Rules	Reference path
placement	axis2_placement_3d	10303-42		<pre> path_feature_component &lt;=   shape_aspect   shape_definition = shape_aspect   shape_definition characterized_definition = shape_definition characterized_definition &lt;-   property_definition.definition   property_definition &lt;-   property_definition_representation.definition   { property_definition_representation =&gt;   shape_definition_representation }   property_definition_representation property_definition_representation.used_representation -&gt;   {representation =&gt;   shape_representation =&gt;   shape_representation_with_parameters}   representation   representation.items[i] -&gt;   {representation_item.name = 'orientation'}   representation_item =&gt;   geometric_representation_item =&gt;   placement =&gt;   axis2_placement_3d </pre>
TWO5D_MANUFACTURING_- FEATURE	instanced_feature	10303-522		<pre> instanced_feature &lt;=   [shape_aspect]   [feature_definition &lt;=   characterized_object] </pre>

**Table 4 — Mapping table for manufacturing features UoF (continued)**

Application element	AIM element	Source	Rules	Reference path
feature_placement	axis2_placement_3d	10303-42		<pre> instantiated_feature &lt;= feature_definition &lt;= characterized_object characterized_definition = characterized_object characterized_definition &lt;- property_definition.definition { property_definition =&gt; product_definition_shape } property_definition &lt;- property_definition_representation.definition { property_definition_representation =&gt; shape_definition_representation } property_definition_representation property_definition_representation.used_representation -&gt; {representation =&gt; shape_representation =&gt; shape_representation_with_parameters} representation representation.items[i] -&gt; {representation_item.name = 'orientation' } representation_item =&gt; geometric_representation_item =&gt; placement =&gt; axis2_placement_3d See NOTE 15 </pre>
VEE_PROFILE	vee_profile	10303-522		<pre> vee_profile &lt;= shape_aspect </pre>

**Table 4 — Mapping table for manufacturing features UoF (continued)**

Application element	AIM element	Source	Rules	Reference path
profile_radius	length_measure_with_unit	10303-41		<pre> vee_profile &lt;=   shape_aspect   shape_definition = shape_aspect   shape_definition characterized_definition = shape_definition characterized_definition &lt;-   property_definition.definition   property_definition &lt;-   property_definition_representation.definition   { property_definition_representation =&gt;   shape_definition_representation }   property_definition_representation property_definition_representation.used_representation -&gt;   {representation =&gt;   shape_representation =&gt;   shape_representation_with_parameters}   representation   representation.items[j] -&gt;   {representation_item.name = 'profile radius'}   representation_item =&gt;   measure_representation_item &lt;=   measure_with_unit =&gt;   length_measure_with_unit </pre>

**Table 4 — Mapping table for manufacturing features UoF (continued)**

Application element	AIM element	Source	Rules	Reference path
profile_angle	plane_angle_measure_with_unit	10303-41		<pre> vee_profile &lt;=   shape_aspect   shape_definition = shape_aspect   shape_definition characterized_definition = shape_definition characterized_definition &lt;-   property_definition.definition   property_definition &lt;-   property_definition_representation.definition { property_definition_representation =&gt;   shape_definition_representation } property_definition_representation property_definition_representation.used_representation -&gt;   {representation =&gt;   shape_representation =&gt;   shape_representation_with_parameters}   representation   representation.items[i] -&gt;   {representation_item.name = 'profile angle'}   representation_item =&gt;   measure_representation_item &lt;=   measure_with_unit =&gt;   plane_angle_measure_with_unit                     </pre>

**Table 4 — Mapping table for manufacturing features UoF (continued)**

Application element	AIM element	Source	Rules	Reference path
tilt_angle	plane_angle_measure_with_unit	10303-41		<pre> vee_profile &lt;=   shape_aspect   shape_definition = shape_aspect   shape_definition characterized_definition = shape_definition characterized_definition &lt;-   property_definition.definition   property_definition &lt;-   property_definition_representation.definition { property_definition_representation =&gt;   shape_definition_representation } property_definition_representation property_definition_representation.used_representation -&gt;   {representation =&gt;   shape_representation =&gt;   shape_representation_with_parameters}   representation   representation.items[i] -&gt;   {representation_item.name = 'tilt_angle'}   representation_item =&gt;   measure_representation_item &lt;=   measure_with_unit =&gt;   plane_angle_measure_with_unit                     </pre>



**Table 4 — Mapping table for manufacturing features UoF (continued)**

Application element	AIM element	Source	Rules	Reference path
first_side_length	length_measure_with_unit	10303-41		<pre> vee_profile &lt;=   shape_aspect   shape_definition = shape_aspect   shape_definition characterized_definition = shape_definition characterized_definition &lt;-   property_definition.definition   property_definition &lt;-   property_definition_representation.definition { property_definition_representation =&gt;   shape_definition_representation } property_definition_representation property_definition_representation.used_representation -&gt;   {representation =&gt;   shape_representation =&gt;   shape_representation_with_parameters}   representation   representation.items[j] -&gt;   {representation_item.name = 'first side length'}   representation_item =&gt;   measure_representation_item &lt;=   measure_with_unit =&gt;   length_measure_with_unit </pre>

**Table 4 — Mapping table for manufacturing features UoF (continued)**

Application element	AIM element	Source	Rules	Reference path
second_side_length	length_measure_with_unit	10303-41		<pre> vee_profile &lt;=   shape_aspect   shape_definition = shape_aspect   shape_definition characterized_definition = shape_definition characterized_definition &lt;-   property_definition.definition   property_definition &lt;-   property_definition_representation.definition   { property_definition_representation =&gt;   shape_definition_representation }   property_definition_representation property_definition_representation.used_representation -&gt;   {representation =&gt;   shape_representation =&gt;   shape_representation_with_parameters}   representation   representation.items[j] -&gt;   {representation_item.name = 'second side length'}   representation_item =&gt;   measure_representation_item &lt;=   measure_with_unit =&gt;   length_measure_with_unit </pre>
WOODRUFF_SLOT_END_TYPE	slot_end	10303-522		<pre> slot_end &lt;=   shape_aspect   { shape_aspect.description = 'woodruff' } </pre>

**Table 4 — Mapping table for manufacturing features UoF (continued)**

Application element	AIM element	Source	Rules	Reference path
radius	length_measure_with_unit	10303-41		<pre> slot_end &lt;= shape_aspect shape_definition = shape_aspect shape_definition characterized_definition = shape_definition characterized_definition &lt;- property_definition.definition property_definition &lt;- property_definition_representation.definition { property_definition_representation =&gt; shape_definition_representation } property_definition_representation property_definition_representation.used_representation -&gt; {representation =&gt; shape_representation_with_parameters} representation representation.items[i] -&gt; {representation_item.name = 'radius'} representation_item =&gt; measure_representation_item &lt;= measure_with_unit =&gt; length_measure_with_unit                     </pre>

**Table 5 — Mapping table for executable UoF**

Application element	AIM element	Source	Rules	Reference path
AND_EXPRESSION	and_expression	13584-20		<pre> and_expression &lt;= multiple_arity_boolean_expression &lt;= [ boolean_expression &lt;=   expression &lt;= ] [ multiple_arity_generic_expression &lt;= ] generic_expression                     </pre>
ASSIGNMENT	machining_process_executable	10303-238		<pre> machining_process_executable &lt;= action_method { action_method.description = 'assignment' }                     </pre>
assignment to nc_variable (as its_lvalue)	PATH			<pre> machining_process_executable &lt;= action_method characterized_action_definition = action_method characterized_action_definition &lt;-   action_property.definition   { action_property.name = 'lvalue' }   action_property &lt;-     action_property_representation.property     action_property_representation     action_property_representation.representation -&gt;       representation       representation.items[i] -&gt;         representation_item =&gt;           expression_representation_item                     </pre>

**Table 5 — Mapping table for executable UoF (continued)**

Application element	AIM element	Source	Rules	Reference path
assignment to rvalve (as its_rvalue)	PATH			<pre> machining_process_executable &lt;=   action_method characterized_action_definition = action_method characterized_action_definition &lt;-   action_property_definition { action_property.name = 'rvalue' }   action_property &lt;- action_property_representation.property action_property_representation action_property_representation.representation -&gt;   representation representation.items[i] -&gt;   representation_item =&gt; expression_representation_item                     </pre>
BINARY_BOOLEAN_EXPRESSION	binary_boolean_expression	13584-20		<pre> binary_boolean_expression &lt;= [ boolean_expression &lt;=   expression &lt;= ] [ binary_generic_expression &lt;= ]   generic_expression                     </pre>
binary_boolean_expression to boolean_expression (as operand1)	PATH			<pre> binary_boolean_expression &lt;=   binary_generic_expression binary_generic_expression.operands[1] -&gt;   generic_expression =&gt;   expression =&gt;   boolean_expression                     </pre>
binary_boolean_expression to boolean_expression (as operand2)	PATH			<pre> binary_boolean_expression &lt;=   binary_generic_expression binary_generic_expression.operands[2] -&gt;   generic_expression =&gt;   expression =&gt;   boolean_expression                     </pre>

**Table 5 — Mapping table for executable UoF (continued)**

Application element	AIM element	Source	Rules	Reference path
BOOLEAN_EXPRESSION	boolean_expression	13584-20		boolean_expression <= expression <= generic_expression
CHANNEL	representation	10303-43		representation { representation.name = 'channel' }
its_id	descriptive_representation_item.- description	10303-45		representation representation.items[] -> representation_item => descriptive_representation_item descriptive_representation_item.description
COMPARISON_EQUAL	comparison_equal	13584-20		comparison_equal <= comparison_expression <= [ boolean_expression <= expression <= ] [ binary_generic_expression <= ] generic_expression
COMPARISON_EXPRESSION	comparison_expression	13584-20		comparison_expression <= [ boolean_expression <= expression <= ] [ binary_generic_expression <= ] generic_expression
comparison_expression to nc_variable (as operand1)	PATH			comparison_expression <= binary_generic_expression binary_generic_expression.operands[] -> generic_expression => expression => numeric_expression => simple_numeric_expression => numeric_variable

Table 5 — Mapping table for executable UoF (continued)

Application element	AIM element	Source	Rules	Reference path
comparison_expression to rvalve (as operand2)	PATH			comparison_expression <= binary_generic_expression binary_generic_expression.operands[2] -> generic_expression => expression => numeric_expression => simple_numeric_expression => (numeric_variable) (literal_number)
COMPARISON_GREATER	comparison_greater	13584-20		comparison_greater <= comparison_expression <= [ boolean_expression <= expression <= ] [ binary_generic_expression <= generic_expression
COMPARISON_GREATER_EQUAL	comparison_greater_equal	13584-20		comparison_greater_equal <= comparison_expression <= [ boolean_expression <= expression <= ] [ binary_generic_expression <= generic_expression
COMPARISON_LESS	comparison_less	13584-20		comparison_less <= comparison_expression <= [ boolean_expression <= expression <= ] [ binary_generic_expression <= generic_expression
COMPARISON_LESS_EQUAL	comparison_less_equal	13584-20		comparison_less_equal <= comparison_expression <= [ boolean_expression <= expression <= ] [ binary_generic_expression <= generic_expression

**Table 5 — Mapping table for executable UoF (continued)**

Application element	AIM element	Source	Rules	Reference path
COMPARISON_NOT_EQUAL	comparison_not_equal	13584-20		comparison_not_equal <= comparison_expression <= [ boolean_expression <= expression <= ] [ binary_generic_expression <= ] generic_expression
DISPLAY_MESSAGE	machining_nc_function	10303-238		machining_nc_function <= machining_process_executable <= action_method { action_method.description = 'display message' }
its_text	descriptive_representation_item.- description	10303-45		machining_nc_function <= machining_process_executable <= action_method characterized_action_definition = action_method characterized_action_definition <- action_property_definition { action_property.name = 'message text' } action_property <- action_property_representation.property action_property_representation action_property_representation.representation -> representation representation.items[i] -> representation_item => descriptive_representation_item descriptive_representation_item.description
EXECUTABLE	machining_process_executable	10303-238		machining_process_executable <= action_method
its_id	action_method.name	10303-41		machining_process_executable <= action_method action_method.name



**Table 5 — Mapping table for executable UoF (continued)**

Application element	AIM element	Source	Rules	Reference path
EXTENDED_NC_FUNCTION	machining_nc_function	10303-238		<pre> machining_nc_function &lt;= machining_process_executable &lt;= action_method { action_method.description = 'extended function' }</pre>
description	descriptive_representation_item.-description	10303-45		<pre> machining_nc_function &lt;= machining_process_executable &lt;= action_method characterized_action_definition = action_method characterized_action_definition &lt;- action_property.definition { action_property.name = 'description' } action_property &lt;- action_property_representation.property action_property_representation action_property_representation.representation -&gt; representation representation.items[i] -&gt; representation_item =&gt; descriptive_representation_item descriptive_representation_item.description</pre>
IF_STATEMENT	machining_process_executable	10303-238		<pre> machining_process_executable &lt;= action_method { action_method.description = 'if statement' }</pre>

**Table 5 — Mapping table for executable UoF (continued)**

Application element	AIM element	Source	Rules	Reference path
if_statement to boolean_expression (as condition)	PATH			machining_process_executable <= action_method characterized_action_definition = action_method characterized_action_definition <- action_property_definition { action_property.name = 'condition' } action_property <- action_property_representation.property action_property_representation action_property_representation.representation -> representation representation.items[i] -> representation_item => expression_representation_item <= generic_expression => expression => boolean_expression
if_statement to executable (as true_branch)	PATH			machining_process_executable <= action_method <- action_method_relationship.relation_method { action_method_relationship => machining_process_body_relationship => machining_process_branch_relationship } { action_method_relationship.name = 'true branch' } action_method_relationship.related_method -> action_method => machining_process_executable

**Table 5 — Mapping table for executable UoF (continued)**

Application element	AIM element	Source	Rules	Reference path
if_statement to executable (as false_branch)	PATH			<pre> machining_process_executable &lt;=   action_method &lt;-     action_method_relatining_method     { action_method_relatining_method =&gt;       machining_process_body_relatining_method =&gt;       machining_process_branch_relatining_method }     { action_method_relatining_method.name = 'false branch' }   action_method_relatining_method_relatining_method -&gt;     action_method =&gt;       machining_process_executable </pre>
IN_PROCESS_GEOMETRY	<action_property>	10303-49	10303-49	<pre> &lt; action_property { action_property.name = 'as-is shape' } &gt; &lt; action_property { action_property.name = 'to-be shape' } &gt; &lt; action_property { action_property.name = 'removal shape' } &gt; </pre>

**Table 5 — Mapping table for executable UoF (continued)**

Application element	AIM element	Source	Rules	Reference path
as_is	shape_representation	10303-41		<pre> action_property &lt;- { action_property.name = 'as-is shape' } action_property_representation.property action_property_representation action_property_representation.representation -&gt; representation =&gt; shape_representation { shape_representation =&gt; (advanced_brep_shape_representation) (edge_based_wireframe_shape_representation) (faceted_brep_shape_representation) (geometrically_bounded_surface_shape_representation) (geometrically_bounded_wireframe_shape_representation) (manifold_surface_shape_representation) (non_manifold_surface_shape_representation) (shell_based_wireframe_shape_representation) }                     </pre>
to_be	shape_representation	10303-41		<pre> action_property &lt;- { action_property.name = 'to-be shape' } action_property_representation.property action_property_representation action_property_representation.representation -&gt; representation =&gt; shape_representation { shape_representation =&gt; (advanced_brep_shape_representation) (edge_based_wireframe_shape_representation) (faceted_brep_shape_representation) (geometrically_bounded_surface_shape_representation) (geometrically_bounded_wireframe_shape_representation) (manifold_surface_shape_representation) (non_manifold_surface_shape_representation) (shell_based_wireframe_shape_representation) }                     </pre>

Table 5 — Mapping table for executable UoF (continued)

Application element	AIM element	Source	Rules	Reference path
removal	shape_representation	10303-41		<pre> action_property &lt;- { action_property.name = 'removal shape' } action_property_representation.property action_property_representation action_property_representation-&gt; representation =&gt; shape_representation { shape_representation =&gt; (advanced_brep_shape_representation) (edge_based_wireframe_shape_representation) (faceted_brep_shape_representation) (geometrically_bounded_surface_shape_representation) (geometrically_bounded_wireframe_shape_representation) (manifold_surface_shape_representation) (non_manifold_surface_shape_representation) (shell_based_wireframe_shape_representation) } </pre>
MACHINE_AXIS_TRAVEL	measure_with_unit	10303-41		<pre> measure_with_unit =&gt; measure_representation_item &lt;= representation_item { representation_item &lt;- representation.items[j] representation &lt;- resource_property_representation.representation resource_property_representation resource_property_representation.property -&gt; resource_property resource_property.name = 'axis travel' } </pre>
axis_identifier	representation_item.name	10303-41		<pre> measure_with_unit measure_representation_item &lt;= representation_item representation_item.name </pre>
travel_distance	measure_with_unit	10303-41		IDENTICAL MAPPING

**Table 5 — Mapping table for executable UoF (continued)**

Application element	AIM element	Source	Rules	Reference path
MACHINE_PARAMETERS	machining_execution_resource	10303-238		machining_execution_resource <= action_resource
machine_parameters to machine_axis_travel (as axis_travel)	PATH			machining_execution_resource <= action_resource characterized_resource_definition = action_resource characterized_resource_definition <- resource_property.resource { resource_property.name = 'axis travel' } resource_property <- resource_property_representation.property resource_property_representation resource_property_representation.representation -> representation representation.items[i] -> representation_item => measure_representation_item <= measure_with_unit => length_measure_with_unit

**Table 5 — Mapping table for executable UoF (continued)**

Application element	AIM element	Source	Rules	Reference path
feedrate	measure_with_unit	10303-41		<pre> maching_execution_resource &lt;=   action_resource characterized_resource_definition = action_resource characterized_resource_definition &lt;-   resource_property.resource { resource_property.name = 'feedrate' } resource_property &lt;-   resource_property_representation.property resource_property_representation resource_property_representation.representation -&gt;   { representation =&gt;     machining_feed_speed_representation } representation { representation.name = 'feed speed' } representation.items[i] -&gt; { representation_item.name = 'feed speed' } representation_item =&gt;   measure_representation_item &lt;=     measure_with_unit measure_value { measure_with_unit.value_component -&gt;   measure_value   numeric_measure } </pre>

**Table 5 — Mapping table for executable UoF (continued)**

Application element	AIM element	Source	Rules	Reference path
number_of_control_axis	count_measure	10303-41		<pre> maching_execution_resource &lt;=   action_resource characterized_resource_definition = action_resource characterized_resource_definition &lt;-   resource_property.resource { resource_property.name = 'number of control axis' }   resource_property &lt;-     resource_property_representation.property   resource_property_representation resource_property_representation &lt;-&gt;   representation   representation.items[i] -&gt;     representation_item =&gt;       measure_representation_item &lt;=         measure_with_unit =&gt;           measure_with_unit.value_component -&gt;             measure_value             measure_value = count_measure             count_measure </pre>



**Table 5 — Mapping table for executable UoF (continued)**

Application element	AIM element	Source	Rules	Reference path
number_of_simultaneous_axis	count_measure	10303-41		<pre> machining_execution_resource &lt;=   action_resource characterized_resource_definition = action_resource characterized_resource_definition &lt;-   resource_property.resource { resource_property.name = 'number of simultaneous axis' } resource_property &lt;-   resource_property_representation.property resource_property_representation resource_property_representation.representation -&gt;   representation representation.items[i] -&gt;   representation_item =&gt;   measure_representation_item &lt;=   measure_with_unit =&gt;   measure_with_unit.value_component -&gt;   measure_value measure_value = count_measure count_measure                     </pre>
positioning_accuracy	length_measure_with_unit	10303-41		<pre> machining_execution_resource &lt;=   action_resource characterized_resource_definition = action_resource characterized_resource_definition &lt;-   resource_property.resource { resource_property.name = 'positioning accuracy' } resource_property &lt;-   resource_property_representation.property resource_property_representation resource_property_representation.representation -&gt;   representation representation.items[i] -&gt;   representation_item =&gt;   measure_representation_item &lt;=   length_measure_with_unit length_measure_with_unit                     </pre>

**Table 5 — Mapping table for executable UoF (continued)**

Application element	AIM element	Source	Rules	Reference path
spindle_power	measure_with_unit	10303-41		<pre> maching_execution_resource &lt;=   action_resource characterized_resource_definition = action_resource characterized_resource_definition &lt;-   resource_property.resource { resource_property.name = 'spindle power' } resource_property &lt;- resource_property_representation.property resource_property_representation resource_property_representation.representation -&gt;   representation representation.items[i] -&gt;   representation_item =&gt;   measure_representation_item &lt;=   measure_with_unit { measure_with_unit.value_component -&gt;   measure_value   measure_value = numeric_measure   numeric_measure } </pre>

**Table 5 — Mapping table for executable UoF (continued)**

Application element	AIM element	Source	Rules	Reference path
spindle_torque	measure_with_unit	10303-41		<pre> maching_execution_resource &lt;=   action_resource characterized_resource_definition = action_resource characterized_resource_definition &lt;-   resource_property.resource { resource_property.name = 'spindle torque' } resource_property &lt;-   resource_property_representation.property resource_property_representation resource_property_representation-&gt;   representation representation.items[i] -&gt;   representation_item =&gt;   measure_representation_item &lt;=   measure_with_unit { measure_with_unit.value_component -&gt;   measure_value   measure_value = numeric_measure   numeric_measure } </pre>

**Table 5 — Mapping table for executable UoF (continued)**

Application element	AIM element	Source	Rules	Reference path
spindle_speed	measure_with_unit	10303-41		<pre> maching_execution_resource &lt;=   action_resource characterized_resource_definition = action_resource characterized_resource_definition &lt;-   resource_property.resource { resource_property.name = 'spindle' } resource_property &lt;-   resource_property_representation.property resource_property_representation resource_property_representation.representation -&gt;   { representation =&gt;     machining_spindle_speed_representation } { representation.name = 'spindle speed' } representation.items[i] -&gt; { representation_item.name = 'rotational speed' } representation_item =&gt;   measure_representation_item &lt;=     measure_with_unit measure_with_unit.value_component -&gt;   measure_value measure_value = numeric_measure numeric_measure } </pre>

**Table 5 — Mapping table for executable UoF (continued)**

Application element	AIM element	Source	Rules	Reference path
table_indexing	descriptive_representation_item.-description	10303-45		<pre> maching_execution_resource &lt;=   action_resource characterized_resource_definition = action_resource characterized_resource_definition &lt;-   resource_property.resource { resource_property.name = 'table indexing' } resource_property &lt;-   resource_property_representation.property resource_property_representation resource_property_representation-&gt;   representation representation.items[i] -&gt;   representation_item =&gt;   descriptive_representation_item descriptive_representation_item.description { (descriptive_representation_item.description = 'required' ) (descriptive_representation_item.description = 'not required' ) } </pre>
table_length	length_measure_with_unit	10303-41		<pre> maching_execution_resource &lt;=   action_resource characterized_resource_definition = action_resource characterized_resource_definition &lt;-   resource_property.resource { resource_property.name = 'table length' } resource_property &lt;-   resource_property_representation.property resource_property_representation resource_property_representation-&gt;   representation representation.items[i] -&gt;   representation_item =&gt;   measure_representation_item &lt;=   measure_with_unit =&gt;   length_measure_with_unit </pre>

**Table 5 — Mapping table for executable UoF (continued)**

Application element	AIM element	Source	Rules	Reference path
table_width	length_measure_with_unit	10303-41		<pre> maching_execution_resource &lt;=   action_resource characterized_resource_definition = action_resource characterized_resource_definition &lt;-   resource_property.resource   { resource_property.name = 'table width' } resource_property &lt;-   resource_property_representation.property resource_property_representation resource_property_representation.representation -&gt;   representation representation.items[i] -&gt;   representation_item =&gt; measure_representation_item &lt;=   measure_with_unit =&gt; length_measure_with_unit                     </pre>
work_volume_height	length_measure_with_unit	10303-41		<pre> maching_execution_resource &lt;=   action_resource characterized_resource_definition = action_resource characterized_resource_definition &lt;-   resource_property.resource   { resource_property.name = 'work volume height' } resource_property &lt;-   resource_property_representation.property resource_property_representation resource_property_representation.representation -&gt;   representation representation.items[i] -&gt;   representation_item =&gt; measure_representation_item &lt;=   measure_with_unit =&gt; length_measure_with_unit                     </pre>

**Table 5 — Mapping table for executable UoF (continued)**

Application element	AIM element	Source	Rules	Reference path
work_volume_length	length_measure_with_unit	10303-41		<pre> machining_execution_resource &lt;=   action_resource characterized_resource_definition = action_resource characterized_resource_definition &lt;-   resource_property.resource { resource_property.name = 'work volume length' }   resource_property &lt;- resource_property_representation.property resource_property_representation resource_property_representation.representation -&gt;   representation representation.items[i] -&gt;   representation_item =&gt; measure_representation_item &lt;=   measure_with_unit =&gt; length_measure_with_unit </pre>
work_volume_width	length_measure_with_unit	10303-41		<pre> machining_execution_resource &lt;=   action_resource characterized_resource_definition = action_resource characterized_resource_definition &lt;-   resource_property.resource { resource_property.name = 'work volume width' }   resource_property &lt;- resource_property_representation.property resource_property_representation resource_property_representation.representation -&gt;   representation representation.items[i] -&gt;   representation_item =&gt; measure_representation_item &lt;=   measure_with_unit =&gt; length_measure_with_unit </pre>
MACHINING_TOOL	machining_tool	10303-238		<pre> machining_tool &lt;=   action_resource </pre>

**Table 5 — Mapping table for executable UoF (continued)**

Application element	AIM element	Source	Rules	Reference path
its_id	action_resource.name	10303-41		<pre> machining_tool &lt;= action_resource action_resource.name                     </pre>
machining_tool to tool_usage (as its_usage)	PATH			<pre> machining_tool &lt;= action_resource &lt;- requirement_for_action_resource &lt;= action_resource_requirement action_resource_requirement.operations[] -&gt; characterized_action_definition characterized_action_definition.action_method action_method =&gt; machining_tool_usage                     </pre>
MACHINING_WORKINGSTEP	machining_workingstep	10303-238		<pre> machining_workingstep &lt;= machining_process_executable &lt;= action_method { action_method.description = 'machining' }                     </pre>



**Table 5 — Mapping table for executable UoF (continued)**

Application element	AIM element	Source	Rules	Reference path
machining_workingstep to manufacturing_feature (as its_feature)	PATH		8	<pre> machining_workingstep &lt;= machining_process_executable &lt;=   action_method &lt;- action_method_relationship.relatng_method   action_method_relationship { action_method_relationship =&gt;   machining_feature_relationship } action_method_relationship.related_method -&gt;   { action_method =&gt;     machining_process_executable =&gt;     machining_feature_process }   action_method &lt;-   action_chosen_method   { action.name = 'machining' }   action =&gt;     property_process &lt;-     process_property_association.process     process_property_association process_property_association.property_or_shape -&gt;   property_or_shape_select   property_or_shape_select = shape_definition   shape_definition = shape_aspect   shape_aspect                     </pre>

**Table 5 — Mapping table for executable UoF (continued)**

Application element	AIM element	Source	Rules	Reference path
<p>machining_workingstep to manufacturing_feature (as final_features)</p>	<p>PATH</p>		<p>8</p>	<pre> machining_workingstep &lt;= machining_process_executable &lt;=   action_method &lt;- action_method_relationship.relatng_method   action_method_relationship   { action_method_relationship =&gt; machining_final_feature_relationship } action_method_relationship.related_method -&gt;   { action_method =&gt; machining_process_executable =&gt; machining_feature_process }   action_method &lt;-   action_chosen_method   { action.name = 'machining' }     action =&gt;   property_process &lt;-   process_property_association.process   process_property_association   process_property_association.property_or_shape -&gt;   property_or_shape_select   property_or_shape_select = shape_definition   shape_definition   shape_definition = shape_aspect   shape_aspect </pre>
<p>machining_workingstep to machining_operation (as its_operation)</p>	<p>PATH</p>			<pre> machining_workingstep &lt;= machining_process_executable &lt;=   action_method &lt;- action_method_relationship.relatng_method   { action_method_relationship =&gt; machining_operation_relationship }   action_method_relationship.related_method -&gt;   action_method =&gt;   machining_operation </pre>

Table 5 — Mapping table for executable UoF (continued)

Application element	AIM element	Source	Rules	Reference path
machining_workingstep to in_process_geometry (as its_effect)	PATH			<pre> machining_workingstep &lt;= machining_process_executable &lt;=   action_method characterized_action_definition = action_method characterized_action_definition &lt;-   action_property.definition   &lt; action_property   { action_property.name = 'as-is shape' } &gt;   &lt; action_property   { action_property.name = 'to-be shape' } &gt;   &lt; action_property   { action_property.name = 'removal shape' } &gt; </pre>
toolpath_orientation	axis2_placement_3d	10303-42		<pre> machining_workingstep &lt;= machining_process_executable &lt;=   action_method characterized_action_definition = action_method characterized_action_definition &lt;-   action_property.definition   { action_property.name = 'toolpath orientation' }   &lt; action_property &lt;-   action_property_representation.property   action_property_representation   action_property_representation.representation -&gt;   representation.items[i] -&gt;   representation_item =&gt;   geometric_representation_item =&gt;   placement =&gt;   axis2_placement_3d </pre>
MULTIPLE_ARITY_BOOLEAN_- EXPRESSION	multiple_arity_boolean_expression	13584-20		<pre> multiple_arity_boolean_expression &lt;=   [ boolean_expression &lt;=   expression &lt;= ]   [ multiple_arity_generic_expression &lt;= ]   generic_expression </pre>

**Table 5 — Mapping table for executable UoF (continued)**

Application element	AIM element	Source	Rules	Reference path
multiple_arity_boolean_expression to boolean_expression (as operands)	PATH			multiple_arity_boolean_expression <= multiple_arity_generic_expression multiple_arity_generic_expression.operands[i] -> generic_expression => expression => boolean_expression
NC_CONSTANT	[ literal_number ] [ expression_representation_item ]	13584-20 10303-238		expression_representation_item <= generic_expression => expression => numeric_expression => simple_numeric_expression => literal_number => (int_literal) (real_literal)
its_name	representation_item.name	10303-41		expression_representation_item <= representation_item representation_item.name
its_value	literal_number.the_value	13584-20		
NC_FUNCTION	machining_nc_function	10303-238		machining_nc_function <= machining_process_executable <= action_method
NC_VARIABLE	[ numeric_variable ] [ expression_representation_item ]	13584-20 10303-238	9	expression_representation_item <= generic_expression => expression => numeric_expression => simple_numeric_expression => numeric_variable => (int_numeric_variable) (real_numeric_variable)

**Table 5 — Mapping table for executable UoF (continued)**

Application element	AIM element	Source	Rules	Reference path
its_name	representation_item.name	10303-41		expression_representation_item <= representation_item representation_item.name
initial_value  See NOTE 16	literal_number.the_value	13584-20	9	expression_representation_item <= representation_item <= representation_item.relation.relation.relation_item { representation_item.relation.description = 'initial value' } representation_item.relation.relation.relation_item <=> representation_item <=> expression_representation_item <= generic_expression => literal_number { literal_number => (int_literal) (real_literal) } literal_number.the_value
NON_SEQUENTIAL	machining_process_executable	10303-238		machining_process_executable <= action_method { action_method.description = 'non-sequential' }
non_sequential_to_executable (as its_elements)	PATH			machining_process_executable <= action_method <= action_method.relation.relation.relation_item { action_method.relation.relation.relation_item => machining_process_body.relation.relation_item action_method.relation.relation.relation_item <=> action_method => machining_process_executable

**Table 5 — Mapping table for executable UoF (continued)**

Application element	AIM element	Source	Rules	Reference path
NOT_EXPRESSION	not_expression	13584-20		<pre> not_expression &lt;= unary_boolean_expression &lt;= [ boolean_expression &lt;= expression &lt;= ] [ unary_generic_expression &lt;= ] generic_expression                     </pre>
OFFSET_VECTOR	machining_offset_vector_ - representation	10303-43		<pre> machining_offset_vector_representation &lt;= representation                     </pre>
offset_vector to nc_variable (as translate)	PATH			<pre> machining_offset_vector_representation &lt;= representation.items[i] -&gt; { representation.item.name = 'translate' } representation_item =&gt; compound_representation_item compound_representation_item.item_element -&gt; compound_item_definition compound_item_definition = list_representation_item list_representation_item[i] -&gt; representation_item =&gt; expression_representation_item                     </pre>
offset_vector to nc_variable (as rotate)	PATH			<pre> machining_offset_vector_representation &lt;= representation representation.items[i] -&gt; { representation.item.name = 'rotate' } representation_item =&gt; compound_representation_item compound_representation_item.item_element -&gt; compound_item_definition compound_item_definition = list_representation_item list_representation_item[i] -&gt; representation_item =&gt; expression_representation_item                     </pre>

Table 5 — Mapping table for executable UoF (continued)

Application element	AIM element	Source	Rules	Reference path
OPTIONAL_STOP	machining_nc_function	10303-238		<pre> machining_nc_function &lt;= machining_process_executable &lt;= action_method { action_method.description = 'optional stop' } </pre>
OR_EXPRESSION	or_expression	13584-20		<pre> or_expression &lt;= multiple_arity_boolean_expression &lt;= [ boolean_expression &lt;= expression &lt;= ] [ multiple_arity_generic_expression &lt;= ] generic_expression </pre>
PARALLEL	machining_process_executable	10303-238		<pre> machining_process_executable &lt;= action_method { action_method.description = 'parallel' } </pre>
parallel to executable (as branches)	PATH			<pre> machining_process_executable &lt;= action_method &lt;- action_method_relationship.relatng_method { action_method_relationship =&gt; [ machining_process_body_relationship =&gt; ] [ concurrent_action_method =&gt; ] machining_process_concurrent_relationship } action_method_relationship.related_method -&gt; action_method =&gt; machining_process_executable </pre>
PROGRAM_STOP	machining_nc_function	10303-238		<pre> machining_nc_function &lt;= machining_process_executable &lt;= action_method { action_method.description = 'program stop' } </pre>
PROGRAM_STRUCTURE	machining_process_executable	10303-238		<pre> machining_process_executable &lt;= action_method </pre>

**Table 5 — Mapping table for executable UoF (continued)**

Application element	AIM element	Source	Rules	Reference path
RAPID_MOVEMENT	machining_rapid_movement	10303-238		<pre> machining_rapid_movement &lt;= [ machining_operation &lt;= ] [ machining_process_executable &lt;= ] action_method                     </pre>
RETURN_HOME	machining_rapid_movement	10303-238		<pre> machining_rapid_movement &lt;= [ machining_operation &lt;= ] [ machining_process_executable &lt;= ] action_method { action_method.description = 'return home' }                     </pre>
SELECTIVE	machining_process_executable	10303-238		<pre> machining_process_executable &lt;= action_method { action_method.description = 'selective' }                     </pre>
selective to executable (as its_elements)	PATH			<pre> machining_process_executable &lt;= action_method &lt;- action_method.relationship.relatng_method { action_method_relationship =&gt; machining_process_body_relationship =&gt; machining_process_branch_relationship } action_method.relationship.related_method -&gt; action_method =&gt; machining_process_executable                     </pre>
SET_MARK	machining_nc_function	10303-238		<pre> machining_nc_function &lt;= machining_process_executable &lt;= action_method { action_method.description = 'set mark' }                     </pre>
SETUP	product_definition_formation	10303-41		<pre> product_definition_formation { product_definition_formation.of_product -&gt; product =&gt; machining_setup }                     </pre>



**Table 5 — Mapping table for executable UoF (continued)**

Application element	AIM element	Source	Rules	Reference path
its_id	product.id	10303-41		<pre> product_definition_formation product_definition_formation.of_product-&gt; product product.id                     </pre>
its_origin	axis2_placement_3d	10303-42		<pre> product_definition_formation &lt;- product_definition.formation product_definition characterized_product_definition = product_definition characterized_definition = characterized_product_definition characterized_definition &lt;- property_definition.definition { property_definition =&gt; product_definition_shape } property_definition represented_definition = property_definition represented_definition &lt;- property_definition_representation.definition {property_definition_representation =&gt; shape_definition_representation } property_definition_representation property_definition_representation.used_representation -&gt; representation representation.items[i] -&gt; {representation_item.name = 'orientation' } representation_item =&gt; geometric_representation_item =&gt; placement =&gt; axis2_placement_3d                     </pre>

**Table 5 — Mapping table for executable UoF (continued)**

Application element	AIM element	Source	Rules	Reference path
setup to elementary_surface (as its_secpplane)	elementary_surface	10303-42		<pre> product_definition_formation &lt;- product_definition.formation product_definition characterized_product_definition = product_definition characterized_product_definition characterized_definition = characterized_product_definition characterized_definition &lt;- characterized_definition &lt;- property_definition.definition { property_definition.name = 'security plane' } property_definition represented_definition = property_definition represented_definition &lt;- property_definition_representation.definition property_definition_representation property_definition_representation.used_representation -&gt; representation representation.items[i] -&gt; representation_item =&gt; geometric_representation_item =&gt; surface =&gt; elementary_surface                     </pre>
setup to workpiece_setup (as its_workpiece_setup)	PATH			<pre> product_definition_formation &lt;- product_definition.formation product_definition &lt;- product_definition.relationship.relatng_product_definition product_definition_relationship =&gt; machining_setup_workpiece_relationship                     </pre>
SETUP_INSTRUCTION	machining_operator_instruction	10303-238		<pre> machining_operator_instruction &lt;= action_method_with_associated_documents &lt;= action_method                     </pre>

Table 5 — Mapping table for executable UoF (continued)

Application element	AIM element	Source	Rules	Reference path
description	action_method.description	10303-41		<pre> machining_operator_instruction &lt;= action_method_with_associated_documents &lt;= action_method action_method.description </pre>
external_document	document.id	10303-41		<pre> machining_operator_instruction &lt;= action_method_with_associated_documents action_method_with_associated_documents.documents[i] -&gt; document document.id </pre>
TOOL_LENGTH_PROBING	machining_touch_probing	10303-238		<pre> machining_touch_probing &lt;= [ machining_operation &lt;= ] [ machining_process_executable &lt;= ] action_method { action_method.description = 'tool length probing' } </pre>
TOOL_PROBING	machining_touch_probing	10303-238		<pre> machining_touch_probing &lt;= [ machining_operation &lt;= ] [ machining_process_executable &lt;= ] action_method { (action_method.description = 'tool length probing') (action_method.description = 'tool radius probing') } </pre>

**Table 5 — Mapping table for executable UoF (continued)**

Application element	AIM element	Source	Rules	Reference path
offset	cartesian_point	10303-42		<pre> machining_touch_probing &lt;= [ machining_operation &lt;= ] [ machining_process_executable &lt;= ] action_method characterized_action_definition = action_method characterized_action_definition &lt;- action_property.definition { action_property.name = 'offset' } action_property &lt;- action_property_representation.property action_property_representation action_property_representation.representation -&gt; representation representation.items[i] -&gt; representation_item =&gt; geometric_representation_item =&gt; point =&gt; cartesian_point                     </pre>

**Table 5 — Mapping table for executable UoF (continued)**

Application element	AIM element	Source	Rules	Reference path
max_wear	positive_length_measure	10303-41		<pre> maching_touch_probing &lt;= [ machining_operation &lt;= ] [ machining_process_executable &lt;= ] action_method characterized_action_definition = action_method characterized_action_definition &lt;- action_property.definition { action_property.name = 'maximum wear' } action_property &lt;- action_property_representation.property action_property_representation action_property_representation.representation -&gt; representation representation.items[i] -&gt; representation_item =&gt; measure_representation_item &lt;= measure_with_unit measure_with_unit.value_component -&gt; measure_value measure_value = positive_length_measure positive_length_measure                     </pre>
tool_probing_to_machining_tool (as its_tool)	PATH			<pre> maching_touch_probing &lt;= [ machining_operation &lt;= ] [ machining_process_executable &lt;= ] action_method supported_item = action_method supported_item &lt;- action_resource.usage[i] action_resource =&gt; machining_tool                     </pre>

**Table 5 — Mapping table for executable UoF (continued)**

Application element	AIM element	Source	Rules	Reference path
TOOL_RADIUS_PROBING	machining_touch_probing	10303-238		<pre> machining_tool_usage &lt;= [ machining_operation &lt;= ] [ machining_process_executable &lt;= ] action_method { action_method.description = 'tool radius probing' }</pre>
TOOL_USAGE	machining_tool_usage	10303-238		<pre> machining_tool_usage &lt;= action_method</pre>
its_carousel	descriptive_representation_item.-description	10303-45		<pre> machining_tool_usage &lt;= action_method characterized_action_definition = action_method characterized_action_definition &lt;- action_property.definition { action_property.name = 'tool carousel' } action_property &lt;- action_property_representation action_property_representation action_property_representation.representation -&gt; representation representation.items[i] -&gt; representation_item =&gt; descriptive_representation_item descriptive_representation_item.description</pre>
its_id	action_method.name	10303-41		<pre> machining_tool_usage &lt;= action_method action_method.name</pre>

**Table 5 — Mapping table for executable UoF (continued)**

Application element	AIM element	Source	Rules	Reference path
<p>tool_usage to externally defined representation (as its_library_reference)</p>	<p>PATH</p>			<pre> machining_tool_usage &lt;=   action_method characterized_action_definition = action_method characterized_action_definition &lt;-   action_property.definition { action_property.name = 'library reference' }   action_property &lt;-   action_property_representation.property   action_property_representation   action_property_representation-&gt;   representation =&gt;   externally_defined_representation_with_parameters                     </pre>
<p>its_position</p>	<p>descriptive_representation_item.-description</p>	<p>10303-45</p>		<pre> machining_tool_usage &lt;=   action_method characterized_action_definition = action_method characterized_action_definition &lt;-   action_property.definition { action_property.name = 'tool position' }   action_property &lt;-   action_property_representation.property   action_property_representation   action_property_representation-&gt;   representation   representation.items[i] -&gt;   representation_item =&gt;   descriptive_representation_item   descriptive_representation_item.description                     </pre>

**Table 5 — Mapping table for executable UoF (continued)**

Application element	AIM element	Source	Rules	Reference path
tool_usage to workpiece (as its_product)	PATH			<pre> machining_tool_usage &lt;=   action_method &lt;-     action.chosen_method   { action.name = 'tool usage' }   action =&gt;     product_definition_process &lt;-       process_product_association.process       process_product_association       process_product_association.defined_product -&gt;       characterized_product_definition       characterized_product_definition = product_definition       product_definition           </pre>
TOUCH_PROBE	representation	10303-43		<pre> representation { representation.name = 'touch probe' }           </pre>
its_id	descriptive_representation_item.- description	10303-45		<pre> representation   representation.items[i] -&gt;   representation_item =&gt;   descriptive_representation_item   descriptive_representation_item.description           </pre>
TOUCH_PROBING	machining_touch_probing	10303-238		<pre> machining_touch_probing &lt;=   [ machining_operation &lt;= ]   [ machining_process_executable &lt;= ]   action_method           </pre>



Table 5 — Mapping table for executable UoF (continued)

Application element	AIM element	Source	Rules	Reference path
touch_probing to nc_variable (as measured_offset)	PATH			<pre> machining_touch_probing &lt;= [ machining_operation &lt;= ] [ machining_process_executable &lt;= ] action_method characterized_action_definition = action_method characterized_action_definition &lt;- action_property.definition { action_property.name = 'measured offset' } action_property &lt;- action_property_representation.property action_property_representation action_property_representation.representation -&gt; representation representation.items[] -&gt; representation_item =&gt; expression_representation_item </pre>
UNARY_BOOLEAN_EXPRESSION	unary_boolean_expression	13584-20		<pre> unary_boolean_expression &lt;= [ boolean_expression &lt;= ] expression &lt;= ] [ unary_generic_expression &lt;= ] generic_expression </pre>
unary_boolean_expression to boolean_expression (as operand)	PATH			<pre> unary_boolean_expression &lt;= unary_generic_expression unary_generic_expression.operand -&gt; generic_expression =&gt; expression =&gt; boolean_expression </pre>
WAIT_FOR_MARK	machining_nc_function	10303-238		<pre> machining_nc_function &lt;= machining_process_executable &lt;= action_method { action_method.description = 'wait for mark' } </pre>

**Table 5 — Mapping table for executable UoF (continued)**

Application element	AIM element	Source	Rules	Reference path
wait_for_mark_to_channel (as its_channel)	PATH			<pre> machining_process_executable &lt;= machining_process_executable &lt;= action_method characterized_action_definition = action_method characterized_action_definition &lt;- action_property.definition { action_property.name = 'channel' } action_property &lt;- action_property_representation.property action_property_representation action_property_representation.representation -&gt; representation                     </pre>
WHILE_STATEMENT	machining_process_executable	10303-238		<pre> machining_process_executable &lt;= action_method { action_method.description = 'while statement' }                     </pre>
while_statement_to_boolean_expression (as condition)	PATH			<pre> machining_process_executable &lt;= action_method characterized_action_definition = action_method characterized_action_definition &lt;- action_property.definition { action_property.name = 'condition' } action_property &lt;- action_property_representation.property action_property_representation action_property_representation.representation -&gt; representation representation.items[j] -&gt; representation_item =&gt; expression_representation_item &lt;= generic_expression =&gt; expression =&gt; boolean_expression                     </pre>

**Table 5 — Mapping table for executable UoF (continued)**

Application element	AIM element	Source	Rules	Reference path
while_statement to executable (as body)	PATH			machining_process_executable <= action_method <- action_method_relationship.relatng_method action_method_relationship { action_method_relationship => machining_process_body_relationship } action_method_relationship.related_method -> action_method => machining_process_executable
WORKINGSTEP #1: if workingstep is a machining_workingstep or turning_workingstep #2: if workingstep is a rapid_movement #3: if workingstep is a touch_probing	#1: (machining_workingstep) #2: (machining_rapid_movement) #3: (machining_touch_probing)	10303-238 10303-238 10303-238		#1: (machining_workingstep <=) #2: (machining_rapid_movement <=) #3: (machining_touch_probing <=) machining_process_executable <= action_method

**Table 5 — Mapping table for executable UoF (continued)**

Application element	AIM element	Source	Rules	Reference path
<p>its_sceplane</p> <p>#1: if workingstep is a machining_workingstep or turning_workingstep</p> <p>#2: if workingstep is a rapid_movement</p> <p>#3: if workingstep is a touch_probing</p>	<p>elementary_surface</p>	<p>10303-42</p>		<pre>#1: (machining_workingstep &lt;=) #2: (machining_rapid_movement &lt;=) #3: (machining_touch_probing &lt;=) machining_process_executable &lt;=   action_method characterized_action_definition = action_method characterized_action_definition &lt;-   action_property.definition { action_property.name = 'security plane' }   action_property &lt;- action_property_representation.property action_property_representation action_property_representation.representation -&gt;   representation representation.items[i] -&gt;   representation_item =&gt; geometric_representation_item =&gt;   surface =&gt;   elementary_surface</pre>
<p>WORKPIECE_COMPLETE_PROBING</p>	<p>machining_touch_probing</p>	<p>10303-238</p>		<pre>machining_touch_probing &lt;= [ machining_operation &lt;= ] [ machining_process_executable &lt;= ]   action_method { action_method.description = 'workpiece complete probing' }</pre>

**Table 5 — Mapping table for executable UoF (continued)**

Application element	AIM element	Source	Rules	Reference path
workpiece_complete_probing to workpiece (as its_workpiece)	PATH			<pre> machining_touch_probing &lt;= [ machining_operation &lt;= ] [ machining_process_executable &lt;= ]   action_method &lt;-   action.chosen_method   { action.name = 'workpiece complete probing' }   action =&gt;   product_definition_process &lt;-   process_product_association.process   process_product_association   process_product_association.defined_product -&gt;   characterized_product_definition   characterized_product_definition = product_definition   product_definition                     </pre>
probing_distance	length_measure_with_unit	10303-41		<pre> machining_touch_probing &lt;= [ machining_operation &lt;= ] [ machining_process_executable &lt;= ]   action_method   characterized_action_definition = action_method   characterized_action_definition &lt;-   action_property.definition   { action_property.name = 'probing distance' }   action_property &lt;-   action_property_representation.property   action_property_representation   action_property_representation.representation -&gt;   representation   representation.items[i] -&gt;   representation_item =&gt;   measure_representation_item &lt;=   measure_with_unit =&gt;   length_measure_with_unit                     </pre>

**Table 5 — Mapping table for executable UoF (continued)**

Application element	AIM element	Source	Rules	Reference path
workpiece_complete_probing to touch_probe (as its_probe)	PATH			<pre> machining_touch_probing &lt;= [ machining_operation &lt;= ] [ machining_process_executable &lt;= ] action_method characterized_action_definition = action_method characterized_action_definition &lt;- action_property.definition { action_property.name = 'probe' } action_property &lt;- action_property_representation.property action_property_representation action_property_representation.representation -&gt; representation                     </pre>
workpiece_complete_probing to offset_vector (as computed_offset)	PATH			<pre> machining_touch_probing &lt;= [ machining_operation &lt;= ] [ machining_process_executable &lt;= ] action_method characterized_action_definition = action_method characterized_action_definition &lt;- action_property.definition { action_property.name = 'computed offset' } action_property &lt;- action_property_representation.property action_property_representation action_property_representation.representation -&gt; representation =&gt; machining_offset_vector_representation                     </pre>
WORKPIECE_PROBING	machining_touch_probing	10303-238		<pre> machining_touch_probing &lt;= [ machining_operation &lt;= ] [ machining_process_executable &lt;= ] action_method { action_method.description = 'workpiece probing' }                     </pre>

**Table 5 — Mapping table for executable UoF (continued)**

Application element	AIM element	Source	Rules	Reference path
start_position	axis2_placement_3d	10303-42		<pre> machining_touch_probing &lt;= [ machining_operation &lt;= ] [ machining_process_executable &lt;= ] action_method characterized_action_definition = action_method characterized_action_definition &lt;- action_property.definition { action_property.name = 'start position' } action_property &lt;- action_property_representation.property action_property_representation action_property_representation.representation -&gt; representation representation.items[] -&gt; representation_item =&gt; geometric_representation_item =&gt; placement =&gt; axis2_placement_3d                     </pre>
workpiece_probing to workpiece (as its_workpiece)	PATH			<pre> machining_touch_probing &lt;= [ machining_operation &lt;= ] [ machining_process_executable &lt;= ] action_method &lt;- action_chosen_method { action.name = 'workpiece probing' } action =&gt; product_definition_process &lt;- process_product_association.process process_product_association process_product_association.defined_product -&gt; characterized_product_definition characterized_product_definition = product_definition product_definition                     </pre>

**Table 5 — Mapping table for executable UoF (continued)**

Application element	AIM element	Source	Rules	Reference path
its_direction	direction	10303-42		<pre> maching_touch_probing &lt;= [ machining_operation &lt;= ] [ machining_process_executable &lt;= ] action_method characterized_action_definition = action_method characterized_action_definition &lt;- action_property.definition { action_property.name = 'direction' } action_property &lt;- action_property_representation.property action_property_representation action_property_representation.representation -&gt; representation representation.items[i] -&gt; representation_item =&gt; geometric_representation_item =&gt; direction                     </pre>
expected_value	length_measure_with_unit	10303-41		<pre> maching_touch_probing &lt;= [ machining_operation &lt;= ] [ machining_process_executable &lt;= ] action_method characterized_action_definition = action_method characterized_action_definition &lt;- action_property.definition { action_property.name = 'expected value' } action_property &lt;- action_property_representation.property action_property_representation action_property_representation.representation -&gt; representation representation.items[i] -&gt; representation_item =&gt; measure_representation_item &lt;= measure_with_unit =&gt; length_measure_with_unit                     </pre>



**Table 5 — Mapping table for executable UoF (continued)**

Application element	AIM element	Source	Rules	Reference path
workpiece_probing to touch_probe (as its_probe)	PATH			<pre> machining_touch_probing &lt;= [ machining_operation &lt;= ] [ machining_process_executable &lt;= ] action_method characterized_action_definition = action_method characterized_action_definition &lt;- action_property.definition { action_property.name = 'probe' } action_property &lt;- action_property_representation.property action_property_representation action_property_representation.representation -&gt; representation                     </pre>
WORKPIECE_SETUP	product_definition_relationship	10303-41		<pre> machining_setup_workpiece_relationship &lt;= product_definition_relationship                     </pre>
workpiece_setup to workpiece (as its_workpiece)	PATH			<pre> machining_setup_workpiece_relationship &lt;= product_definition_relationship product_definition_relationship.related_product_definition -&gt; product_definition                     </pre>

**Table 5 — Mapping table for executable UoF (continued)**

Application element	AIM element	Source	Rules	Reference path
its_origin	axis2_placement_3d	10303-42		machining_setup_workpiece_relationship <= product_definition_relationship product_definition = product_definition_relationship characterized_product_definition characterized_definition = characterized_product_definition characterized_definition <= property_definition.definition property_definition => product_definition_shape <= context_dependent_shape_representation.- represented_product_relation context_dependent_shape_representation context_dependent_shape_representation.- representation_relation -> [ shape_representation_relationship ] [ representation_relationship_with_transformation ] representation_relationship_with_transformation.- transformation_operator -> transformation transformation = item_defined_transformation item_defined_transformation item_defined_transformation.transformation_item_2 -> representation_item => axis2_placement_3d  See NOTE 17

**Table 5 — Mapping table for executable UoF (continued)**

Application element	AIM element	Source	Rules	Reference path
workpiece_setup to offset_vector (as its_offset)	PATH			<pre> machining_setup_workpiece_relationship &lt;=   product_definition_relationship characterized_product_definition = product_definition_relationship characterized_product_definition characterized_definition = characterized_product_definition characterized_definition &lt;-   property_definition.definition { property_definition.name = 'computed offset' }   property_definition   represented_definition = property_definition   represented_definition &lt;-   property_definition.definition   property_definition_representation   property_definition_representation.used_representation -&gt;   representation =&gt;   machining_offset_vector_representation </pre>

**Table 5 — Mapping table for executable UoF (continued)**

Application element	AIM element	Source	Rules	Reference path
<p>workpiece_setup to restricted_area_select (as its_restricted_area)</p> <p>#1: if restricted_area is a block</p> <p>#2: if restricted_area is a right_circular_cylinder</p> <p>#3: if restricted_area is an advanced_brep_shape_representation</p> <p>#4: if restricted_area is a bounded_surface</p>	<p>PATH</p>			<pre> machining_setup_workpiece_relationship &lt;=   product_definition_relationship characterized_product_definition = product_definition_relationship characterized_product_definition characterized_definition = characterized_product_definition characterized_definition &lt;-   property_definition.definition   { property_definition.name = 'restricted area' }   property_definition   represented_definition = property_definition   represented_definition &lt;-   property_definition.definition   property_definition_representation   property_definition_representation.used_representation -&gt;   representation =&gt;   shape_representation =&gt;  #1: (shape_representation_with_parameters =&gt;   block_shape_representation)  #2: (shape_representation_with_parameters =&gt;   cylindrical_shape_representation)  #3: (advanced_brep_shape_representation)  #4: ( geometrically_bounded_surface_shape_representation &lt;=   representation   representation.items[i] -&gt;   representation_item =&gt;   geometric_set   geometric_set.elements[i] -&gt;   geometric_set_select   geometric_set_select = surface   surface =&gt;   bounded_surface) </pre>

**Table 5 — Mapping table for executable UoF (continued)**

Application element	AIM element	Source	Rules	Reference path
workpiece_setup to setup_instruction (as its_instructions)	PATH			<pre> machining_setup_workpiece_relationship &lt;= product_definition_relationship characterized_product_definition = product_definition_relationship characterized_product_definition &lt;- process_product_association.defined_product process_product_association product_definition_process -&gt; product_definition_process &lt;= action { action.name = 'setup instructions' } action.chosen_method -&gt; { action_method =&gt; machining_process_executable } { action_method.description = 'setup instructions' } action_method &lt;- action_method_relatng_method action_method_relatng_method { action_method_relatng_method =&gt; serial_action_method =&gt; sequential_method =&gt; machining_operator_instruction_relationship } action_method_relatng_method_relatng_method -&gt; action_method_relatng_method =&gt; machining_operator_instruction </pre>
WORKPLAN	machining_workplan	10303-238		<p>See NOTE 18</p> <pre> machining_workplan &lt;= machining_process_executable &lt;= action_method </pre>

**Table 5 — Mapping table for executable UoF (continued)**

Application element	AIM element	Source	Rules	Reference path
workplan to executable (as its_elements)	PATH			<pre> machining_workplan &lt;= machining_process_executable &lt;= action_method &lt;- action_method_relationship.relatng_method action_method_relationship { action_method_relationship =&gt; [ machining_process_body_relationship =&gt; ] [ serial_action_method =&gt; sequential_method =&gt; ] machining_process_sequence_relationship } action_method_relationship.related_method -&gt; action_method =&gt; machining_process_executable </pre> <p style="text-align: center;">See NOTE 18</p>
workplan to channel (as its_channel)	PATH			<pre> machining_workplan &lt;= machining_process_executable &lt;= action_method characterized_action_definition = action_method characterized_action_definition &lt;- action_property.definition { action_property.name = 'channel' } action_property &lt;- action_property_representation.property action_property_representation action_property_representation.representation -&gt; representation </pre>

**Table 5 — Mapping table for executable UoF (continued)**

Application element	AIM element	Source	Rules	Reference path
workplan to setup (as its_setup)	PATH			<pre> machining_workplan &lt;= machining_process_executable &lt;=   action_method &lt;-   action.chosen_method   { action.name = 'setup' }   action =&gt;   product_definition_process &lt;-   process_product_association.process   process_product_association   process_product_association.defined_product -&gt;   characterized_product_definition   characterized_product_definition = product_definition   product_definition   product_definition.formation -&gt;   product_definition_formation           </pre>
workplan to in_process_geometry (as its_effect)	PATH			<pre> machining_workplan &lt;= machining_process_executable &lt;=   action_method   characterized_action_definition = action_method   characterized_action_definition &lt;-   action_property.definition   action_property           </pre>
workplan to machine_parameters (as its_minimum_machine_params)	PATH			<pre> machining_workplan &lt;= machining_process_executable &lt;=   action_method   supported_item = action_method   supported_item &lt;-   action_resource.usage[i]   action_resource =&gt;   machining_execution_resource           </pre>

**Table 5 — Mapping table for executable UoF (continued)**

Application element	AIM element	Source	Rules	Reference path
XOR_EXPRESSION	xor_expression	13584-20		xor_expression <= binary_boolean_expression <= [ boolean_expression <= expression <= ] [ binary_generic_expression <= generic_expression



**Table 6 — Mapping table for operation UoF**

Application element	AIM element	Source	Rules	Reference path
MACHINE_FUNCTIONS	machining_functions	10303-238		machining_functions <= action_method
MACHINING_OPERATION	machining_operation	10303-238		machining_operation <= action_method
its_id	action_method.name	10303-49		machining_operation <= action_method action_method.name
retract_plane	length_measure_with_unit	10303-41		machining_operation <= action_method characterized_action_definition = action_method characterized_action_definition <- action_property.definition { action_property.name = 'retract plane' } action_property <- action_property_representation.property action_property_representation action_property_representation.representation -> representation representation.items[j] -> representation_item => measure_representation_item <= measure_with_unit => length_measure_with_unit

**Table 6 — Mapping table for operation UoF (continued)**

Application element	AIM element	Source	Rules	Reference path
start_point	cartesian_point	10303-42		<pre> machining_operation &lt;=   action_method characterized_action_definition = action_method characterized_action_definition &lt;-   action_property_definition { action_property.name = 'cut start point' }   action_property &lt;-   action_property_representation.property   action_property_representation   action_property_representation.representation -&gt;   representation   representation.items[i] -&gt;   representation_item =&gt;   geometric_representation_item =&gt;   point =&gt;   cartesian_point                     </pre>
machining_operation to machining_tool (as its_tool)	PATH			<pre> machining_operation &lt;=   action_method supported_item = action_method   supported_item &lt;-   action_resource.usage[i]   action_resource =&gt;   machining_tool                     </pre>
machining_operation to technology (as its_technology)	PATH			<pre> machining_operation &lt;=   action_method &lt;-   action_method_relationship.relatng_method   action_method_relationship   { action_method_relationship =&gt;   machining_technology_relationship }   action_method_relationship.related_method -&gt;   action_method =&gt;   machining_technology                     </pre>

**Table 6 — Mapping table for operation UoF (continued)**

Application element	AIM element	Source	Rules	Reference path
machining_operation to machine_functions (as its_machine_functions)	PATH			<pre>                     machining_operation &lt;=                     action_method &lt;-                     action_method_relationship.relatng_method                     { action_method_relationship =&gt;                     machining_functions_relationship }                     action_method_relationship.related_method -&gt;                     action_method =&gt;                     machining_functions                     </pre>
OPERATION	machining_operation	10303-238		<pre>                     machining_operation &lt;=                     action_method                     </pre>
operation to toolpath (as its_toolpath)  See NOTE 19	PATH			<pre>                     machining_operation &lt;=                     action_method &lt;-                     action_method_relationship.relatng_method                     { action_method_relationship =&gt;                     serial_action_method =&gt;                     sequential_method =&gt;                     machining_toolpath_sequence_relationship }                     action_method_relationship.related_method -&gt;                     action_method =&gt;                     machining_toolpath                     </pre>

**Table 6 — Mapping table for operation UoF (continued)**

Application element	AIM element	Source	Rules	Reference path
operation to tool_direction (as its_tool_direction)	PATH			machining_operation <= action_method characterized_action_definition = action_method characterized_action_definition <- action_property_definition { action_property.name = 'tool direction' } action_property <- action_property_representation.property action_property_representation action_property_representation.representation -> representation => machining_tool_direction_representation
TECHNOLOGY	machining_technology	10303-238		machining_technology <= action_method

**Table 6 — Mapping table for operation UoF (continued)**

Application element	AIM element	Source	Rules	Reference path
feedrate	measure_with_unit	10303-41		<pre> machining_technology &lt;=   action_method characterized_action_definition = action_method characterized_action_definition &lt;-   action_property_definition { action_property.name = 'feedrate' }   action_property &lt;-   action_property_representation.property   action_property_representation   action_property_representation.representation -&gt;   { representation =&gt;     machining_feed_speed_representation }   representation   { representation.name = 'feed speed' }   representation.items[i] -&gt;   { representation_item.name = 'feed speed' }   representation_item =&gt;   measure_representation_item &lt;=   measure_with_unit   measure_value   { measure_with_unit.value_component -&gt;     measure_value = numeric_measure     numeric_measure } </pre>

**Table 6 — Mapping table for operation UoF (continued)**

Application element	AIM element	Source	Rules	Reference path
feedrate_reference #1: if value is tool center point (mapping may also be omitted if value is tool center point) #2: if value is cutter contact point	descriptive_representation_item	10303-45		<pre> machining_technology &lt;=   action_method characterized_action_definition = action_method characterized_action_definition &lt;-   action_property_definition { action_property.name = 'feedrate reference' }   action_property &lt;-   action_property_representation.property   action_property_representation   action_property_representation.representation -&gt;   representation   representation.items[i] -&gt;   representation_item =&gt;   descriptive_representation_item   descriptive_representation_item.description {#1: ( descriptive_representation_item.description = \ 'tool center point' ) #2: ( descriptive_representation_item.description = \ 'cutter contact point' )}}</pre>
THREE_AXES	machining_tool_direction_- representation	10303-238		<pre> machining_tool_direction_representation &lt;=   representation {representation.name = 'three axes' }</pre>
TOOL_DIRECTION	machining_tool_direction_- representation	10303-238		<pre> machining_tool_direction_representation &lt;=   representation</pre>
TOOLPATH_LIST	NOT MAPPED See NOTE 19			
TWO_AXES	machining_tool_direction_- representation	10303-238		<pre> machining_tool_direction_representation &lt;=   representation {representation.name = 'two axes' }</pre>

**Table 7 — Mapping table for toolpath UoF**

Application element	AIM element	Source	Rules	Reference path
AP_LIFT_PATH_ANGLE	machining_toolpath	10303-238		<pre> machining_toolpath &lt;=   action_method { action_method.description = 'approach lift path angle' }</pre>
angle	plane_angle_measure_with_unit	10303-41		<pre> machining_toolpath &lt;=   action_method characterized_action_definition = action_method characterized_action_definition &lt;-   action_property.definition { action_property.name = 'angle' } action_property &lt;-   action_property_representation.property action_property_representation action_property_representation.representation -&gt;   representation representation.items[i] -&gt;   representation_item =&gt;   measure_representation_item &lt;=   measure_with_unit =&gt;   plane_angle_measure_with_unit</pre>

**Table 7 — Mapping table for toolpath UoF (continued)**

Application element	AIM element	Source	Rules	Reference path
benddist	length_measure_with_unit	10303-41		machining_toolpath <= action_method characterized_action_definition = action_method characterized_action_definition <- action_property_definition { action_property.name = 'bend distance' } action_property <- action_property_representation.property action_property_representation action_property_representation.representation -> representation representation.items[i] -> representation_item => measure_representation_item <= measure_with_unit => length_measure_with_unit
AP_LIFT_PATH_TANGENT	machining_toolpath	10303-238		machining_toolpath <= action_method { action_method.description = 'approach lift path tangent' }



**Table 7 — Mapping table for toolpath UoF (continued)**

Application element	AIM element	Source	Rules	Reference path
radius	length_measure_with_unit	10303-41		<pre> maching_toolpath &lt;=   action_method characterized_action_definition = action_method characterized_action_definition &lt;-   action_property_definition { action_property.name = 'radius' }   action_property &lt;- action_property_representation.property action_property_representation action_property_representation.representation -&gt;   representation representation.items[i] -&gt;   representation_item =&gt; measure_representation_item &lt;=   measure_with_unit =&gt; length_measure_with_unit </pre>
APPROACH_LIFT_PATH	maching_toolpath	10303-238		<pre> maching_toolpath &lt;=   action_method { (action_method.description = 'approach lift path angle') (action_method.description = 'approach lift path tangent') } </pre>

**Table 7 — Mapping table for toolpath UoF (continued)**

Application element	AIM element	Source	Rules	Reference path
fix_point	cartesian_point	10303-42		<pre> maching_toolpath &lt;=   action_method characterized_action_definition = action_method characterized_action_definition &lt;-   action_property_definition { action_property.name = 'fix point' }   action_property &lt;- action_property_representation.property action_property_representation action_property_representation.representation -&gt;   representation representation.items[i] -&gt;   representation_item =&gt; geometric_representation_item =&gt;   point =&gt;   cartesian_point                     </pre>
fix_point_dir	direction	10303-42		<pre> maching_toolpath &lt;=   action_method characterized_action_definition = action_method characterized_action_definition &lt;-   action_property_definition { action_property.name = 'fix point direction' }   action_property &lt;- action_property_representation.property action_property_representation action_property_representation.representation -&gt;   representation representation.items[i] -&gt;   representation_item =&gt; geometric_representation_item =&gt;   direction                     </pre>
AXIS_TRAJECTORY	maching_toolpath	10303-238		<pre> maching_toolpath &lt;=   action_method { action_method.description = 'axis trajectory' }                     </pre>

**Table 7 — Mapping table for toolpath UoF (continued)**

Application element	AIM element	Source	Rules	Reference path
axis_list  See NOTE 20	representation_item.name	10303-43		<pre> machining_toolpath &lt;=   action_method characterized_action_definition = action_method characterized_action_definition &lt;-   action_property.definition { action_property.name = 'axis commands' }   action_property &lt;-   action_property_representation.property   action_property_representation   action_property_representation.representation -&gt;   representation   representation.items[i] -&gt;   { representation_item =&gt;   geometric_representation_item =&gt;     curve =&gt;       bounded_curve }   representation_item   representation_item.name                     </pre>
commands  See NOTE 20	bounded_curve	10303-42		<pre> machining_toolpath &lt;=   action_method characterized_action_definition = action_method characterized_action_definition &lt;-   action_property.definition { action_property.name = 'axis commands' }   action_property &lt;-   action_property_representation.property   action_property_representation   action_property_representation.representation -&gt;   representation   representation.items[i] -&gt;   representation_item =&gt;   geometric_representation_item =&gt;     curve =&gt;       bounded_curve                     </pre>

**Table 7 — Mapping table for toolpath UoF (continued)**

Application element	AIM element	Source	Rules	Reference path
CONNECT_DIRECT	machining_toolpath	10303-238		<pre> machining_toolpath &lt;=   action_method   { action_method.description = 'connect direct' } </pre>
CONNECT_SECPANE	machining_toolpath	10303-238		<pre> machining_toolpath &lt;=   action_method   { action_method.description = 'connect security plane' } </pre>
up_dir	direction	10303-42		<pre> machining_toolpath &lt;=   action_method   characterized_action_definition = action_method   characterized_action_definition &lt;-     action_property.definition     { action_property.name = 'up direction' }     action_property &lt;-       action_property_representation.property       action_property_representation       action_property_representation.representation -&gt;         representation         representation.items[i] -&gt;           representation_item =&gt;             geometric_representation_item =&gt;               direction </pre>

**Table 7 — Mapping table for toolpath UoF (continued)**

Application element	AIM element	Source	Rules	Reference path
down_dir	direction	10303-42		<pre> machining_toolpath &lt;=   action_method characterized_action_definition = action_method characterized_action_definition &lt;-   action_property_definition { action_property.name = 'down direction' }   action_property &lt;- action_property_representation.property action_property_representation action_property_representation-&gt;   representation   representation.items[i] -&gt;   representation_item =&gt; geometric_representation_item =&gt;   direction </pre>
CONNECTOR	machining_toolpath	10303-238		<pre> machining_toolpath &lt;=   action_method { (action_method.description = 'connect direct') (action_method.description = 'connect security plane') } </pre>

**Table 7 — Mapping table for toolpath UoF (continued)**

Application element	AIM element	Source	Rules	Reference path
CURVE_WITH_NORMAL_VECTOR	[ bounded_curve ] [ bounded_curve ]	10303-42 10303-42		<pre>[ bounded_curve &lt;= representation_item &lt;- representation.items[i] representation &lt;- action_property_representation.representation action_property_representation action_property_representation.property -&gt; action_property { action_property.name = 'basic curve' } ]  [ bounded_curve &lt;= representation_item &lt;- representation.items[i] representation &lt;- action_property_representation.representation action_property_representation action_property_representation.property -&gt; action_property { action_property.name = 'surface normal' } ]</pre>
basiccurve	bounded_curve	10303-42		<pre>bounded_curve &lt;= representation_item &lt;- representation.items[i] representation &lt;- action_property_representation.representation action_property_representation action_property_representation.property -&gt; action_property { action_property.name = 'basic curve' }</pre>

Table 7 — Mapping table for toolpath UoF (continued)

Application element	AIM element	Source	Rules	Reference path
surface_normal	bounded_curve	10303-42		<pre> bounded_curve &lt;= representation_item &lt;- representation.items[i] representation &lt;- action_property_representation.representation action_property_representation action_property_representation.property -&gt; action_property { action_property.name = 'surface normal' } </pre>
CUTTER_CONTACT_TRAJECTORY	machining_toolpath	10303-238		<pre> machining_toolpath &lt;= action_method { action_method.description = 'cutter contact trajectory' } </pre>

**Table 7 — Mapping table for toolpath UoF (continued)**

Application element	AIM element	Source	Rules	Reference path
<p>basiccurve</p> <p>#1: if the basiccurve is a bounded_pcurve</p> <p>#2: if the basiccurve is a curve_with_normal_vector</p>	<p>#1: ( bounded_pcurve )</p> <p>#2: ( [ bounded_curve ] [ bounded_curve ] )</p>	<p>10303-42</p> <p>10303-42</p> <p>10303-42</p>		<pre> machining_toolpath &lt;=   action_method characterized_action_definition = action_method characterized_action_definition &lt;-   #1: ( action_property.definition     { action_property.name = 'basic curve' }     action_property &lt;-       action_property_representation.property     action_property_representation   action_property_representation.representation -&gt;     representation   representation.items[i] -&gt;     representation_item =&gt;       bounded_curve =&gt;         bounded_pcurve )  #2: ( [ action_property.definition     { action_property.name = 'basic curve' }     action_property &lt;-       action_property_representation.property     action_property_representation   action_property_representation.representation -&gt;     representation   representation.items[i] -&gt;     representation_item =&gt;       bounded_curve ]   [ action_property.definition     { action_property.name = 'surface normal' }     action_property &lt;-       action_property_representation.property     action_property_representation   action_property_representation.representation -&gt;     representation   representation.items[i] -&gt;     representation_item =&gt;       bounded_curve ] ) </pre>



**Table 7 — Mapping table for toolpath UoF (continued)**

Application element	AIM element	Source	Rules	Reference path
its_toolaxis	bounded_curve	10303-42		<pre> machining_toolpath &lt;=   action_method characterized_action_definition = action_method characterized_action_definition &lt;-   action_property_definition { action_property.name = 'tool axis' }   action_property &lt;-   action_property_representation.property   action_property_representation   action_property_representation-&gt;   representation   representation.items[i] -&gt;   representation_item =&gt;   geometric_representation_item =&gt;   curve =&gt;   bounded_curve </pre>
its_contact_type	descriptive_representation_item	10303-45		<pre> machining_toolpath &lt;=   action_method characterized_action_definition = action_method characterized_action_definition &lt;-   action_property_definition { action_property.name = 'contact type' }   action_property &lt;-   action_property_representation.property   action_property_representation   action_property_representation-&gt;   representation   representation.items[i] -&gt;   representation_item =&gt;   descriptive_representation_item   descriptive_representation_item.description { (descriptive_representation_item.description = 'side' ) (descriptive_representation_item.description = 'front' ) } </pre>

**Table 7 — Mapping table for toolpath UoF (continued)**

Application element	AIM element	Source	Rules	Reference path
path_maximum_deviation	length_measure_with_unit	10303-41		<pre> machining_toolpath &lt;=   action_method characterized_action_definition = action_method characterized_action_definition &lt;-   action_property_definition { action_property.name = 'path maximum deviation' }   action_property &lt;-   action_property_representation.property   action_property_representation   action_property_representation.representation -&gt;   representation   representation.items[i] -&gt;   representation_item =&gt;   measure_representation_item &lt;=   measure_with_unit =&gt;   length_measure_with_unit </pre>
tool_axis_maximum_deviation	plane_angle_measure_with_unit	10303-41		<pre> machining_toolpath &lt;=   action_method characterized_action_definition = action_method characterized_action_definition &lt;-   action_property_definition { action_property.name = 'tool axis maximum deviation' }   action_property &lt;-   action_property_representation.property   action_property_representation   action_property_representation.representation -&gt;   representation   representation.items[i] -&gt;   representation_item =&gt;   measure_representation_item &lt;=   measure_with_unit =&gt;   plane_angle_measure_with_unit </pre>

**Table 7 — Mapping table for toolpath UoF (continued)**

Application element	AIM element	Source	Rules	Reference path
CUTTER_LOCATION_TRAJECTORY	machining_toolpath	10303-238		<pre> machining_toolpath &lt;=   action_method   { action_method.description = 'cutter location trajectory' } </pre>
basiccurve	bounded_curve	10303-42		<pre> machining_toolpath &lt;=   action_method   characterized_action_definition = action_method   characterized_action_definition &lt;-     action_property.definition     { action_property.name = 'basic curve' }     action_property &lt;-       action_property_representation.property       action_property_representation       action_property_representation.representation -&gt;         representation         representation.items[i] -&gt;           representation_item =&gt;             geometric_representation_item =&gt;               curve =&gt;                 bounded_curve </pre>

**Table 7 — Mapping table for toolpath UoF (continued)**

Application element	AIM element	Source	Rules	Reference path
its_toolaxis	bounded_curve	10303-42		<pre> machining_toolpath &lt;=   action_method characterized_action_definition = action_method characterized_action_definition &lt;-   action_property_definition { action_property.name = 'tool axis' }   action_property &lt;- action_property_representation.property action_property_representation action_property_representation-&gt;   representation representation.items[i] -&gt;   representation_item =&gt; geometric_representation_item =&gt;   curve =&gt;   bounded_curve </pre>
surface_normal	bounded_curve	10303-42		<pre> machining_toolpath &lt;=   action_method characterized_action_definition = action_method characterized_action_definition &lt;-   action_property_definition { action_property.name = 'surface normal' }   action_property &lt;- action_property_representation.property action_property_representation action_property_representation-&gt;   representation representation.items[i] -&gt;   representation_item =&gt; geometric_representation_item =&gt;   curve =&gt;   bounded_curve </pre>

**Table 7 — Mapping table for toolpath UoF (continued)**

Application element	AIM element	Source	Rules	Reference path
path_maximum_deviation	length_measure_with_unit	10303-41		<pre> machining_toolpath &lt;=   action_method characterized_action_definition = action_method characterized_action_definition &lt;-   action_property_definition { action_property.name = 'path maximum deviation' }   action_property &lt;-   action_property_representation.property   action_property_representation   action_property_representation.representation -&gt;   representation   representation.items[i] -&gt;   representation_item =&gt;   measure_representation_item &lt;=   measure_with_unit =&gt;   length_measure_with_unit </pre>
tool_axis_maximum_deviation	plane_angle_measure_with_unit	10303-41		<pre> machining_toolpath &lt;=   action_method characterized_action_definition = action_method characterized_action_definition &lt;-   action_property_definition { action_property.name = 'tool axis maximum deviation' }   action_property &lt;-   action_property_representation.property   action_property_representation   action_property_representation.representation -&gt;   representation   representation.items[i] -&gt;   representation_item =&gt;   measure_representation_item &lt;=   measure_with_unit =&gt;   plane_angle_measure_with_unit </pre>

**Table 7 — Mapping table for toolpath UoF (continued)**

Application element	AIM element	Source	Rules	Reference path
FEEDSTOP	machining_toolpath	10303-238		<pre> machining_toolpath &lt;=   action_method   { action_method.description = 'feedstop' } </pre>
dwel	time_measure_with_unit	10303-41		<pre> machining_toolpath &lt;=   action_method   characterized_action_definition = action_method   characterized_action_definition &lt;-     action_property.definition     { action_property.name = 'dwell' }     action_property &lt;-     action_property_representation.property     action_property_representation     action_property_representation.representation -&gt;     { representation =&gt;       machining_dwell_time_representation }     representation     { representation.name = 'dwell time' }     representation.items[i] -&gt;     { representation_item.name = 'dwell time' }     representation_item =&gt;     measure_representation_item &lt;=     measure_with_unit =&gt;     time_measure_with_unit </pre>
PARAMETERISED_PATH	machining_toolpath	10303-238		<pre> machining_toolpath &lt;=   action_method   { (action_method.description = 'approach lift path angle')     (action_method.description = 'approach lift path tangent')     (action_method.description = 'connect direct')     (action_method.description = 'connect security plane') } </pre>
TOOLPATH	machining_toolpath	10303-238		<pre> machining_toolpath &lt;=   action_method </pre>

**Table 7 — Mapping table for toolpath UoF (continued)**

Application element	AIM element	Source	Rules	Reference path
<p>its_priority</p> <p>#1: if value is true</p> <p>#2: if value is false (mapping may also be omitted if value is false)</p>	<p>descriptive_representation_item</p>	<p>10303-45</p>		<pre> machinging_toolpath &lt;=   action_method characterized_action_definition = action_method characterized_action_definition &lt;-   action_property_definition { action_property.name = 'priority' }   action_property &lt;- action_property_representation.property action_property_representation action_property_representation.representation -&gt;   representation   representation.items[i] -&gt;   representation_item =&gt;   descriptive_representation_item   descriptive_representation_item.description {#1: (descriptive_representation_item.description = 'required' ) #2: (descriptive_representation_item.description = 'suggested' ) }                     </pre>

**Table 7 — Mapping table for toolpath UoF (continued)**

Application element	AIM element	Source	Rules	Reference path
<p>its_type</p> <p>#1: if value is approach</p> <p>#2: if value is lift</p> <p>#3: if value is connect</p> <p>#4: if value is non-contact</p> <p>#5: if value is contact</p> <p>#6: if value is trajectory path (mapping may also be omitted if value is trajectory path)</p>				<pre> machining_toolpath &lt;=   action_method characterized_action_definition = action_method characterized_action_definition &lt;-   action_property_definition { action_property.name = 'trajectory type' }   action_property &lt;-   action_property_representation.property   action_property_representation   action_property_representation &lt;-&gt;   representation   representation.items[i] -&gt;   representation_item =&gt;   descriptive_representation_item   descriptive_representation_item.description   descriptive_representation_item.description = 'approach' ) #1: (descriptive_representation_item.description = 'lift' ) #2: (descriptive_representation_item.description = 'connect' ) #3: (descriptive_representation_item.description = 'non-contact' ) #4: (descriptive_representation_item.description = 'contact' ) #5: (descriptive_representation_item.description = \ 'descriptive_representation_item.description = \ 'trajectory path' ) } </pre>



**Table 7 — Mapping table for toolpath UoF (continued)**

Application element	AIM element	Source	Rules	Reference path
its_speed	(descriptive_representation_item) (ratio_measure_with_unit) (bounded_curve)	10303-45 10303-41 10303-42		<pre> machining_toolpath &lt;=   action_method characterized_action_definition = action_method characterized_action_definition &lt;-   action_property_definition { action_property.name = 'speed profile' }   action_property &lt;- action_property_representation.property action_property_representation action_property_representation.representation -&gt; { representation =&gt;   machining_toolpath_speed_profile_representation }   representation   representation.items[i] -&gt; ( representation_item =&gt;   descriptive_representation_item   descriptive_representation_item.description { descriptive_representation_item.description = 'rapid' } ) ( representation_item =&gt;   measure_representation_item &lt;=   measure_with_unit =&gt;   ratio_measure_with_unit ) ( representation_item =&gt;   geometric_representation_item =&gt;   curve =&gt;   bounded_curve ) </pre>

**Table 7 — Mapping table for toolpath UoF (continued)**

Application element	AIM element	Source	Rules	Reference path
toolpath to technology (as its_technology)	PATH			<pre> machining_toolpath &lt;= action_method &lt;- action_method_relationship.relatng_method action_method_relationship { action_method_relationship =&gt; machining_technology_relationship } action_method_relationship.related_method -&gt; action_method =&gt; machining_technology                     </pre>
toolpath to machine_functions (as its_machine_functions)	PATH			<pre> machining_toolpath &lt;= action_method &lt;- action_method_relationship.relatng_method action_method_relationship { action_method_relationship =&gt; machining_functions_relationship } action_method_relationship.related_method -&gt; action_method =&gt; machining_functions                     </pre>
its_id	action_method.name	10303-49		<pre> machining_toolpath &lt;= action_method action_method.name                     </pre>
TOOLPATH_SPEED	bounded_curve	10303-42		<pre> bounded_curve { bounded_curve &lt;- representation.items[i] representation =&gt; machining_toolpath_speed_profile_representation }                     </pre>
speed	IDENTICAL MAPPING			
TRAJECTORY	machining_toolpath	10303-238		<pre> machining_toolpath &lt;= action_method { (action_method.description = 'axis trajectory') (action_method.description = 'cutter contact trajectory') (action_method.description = 'cutter location trajectory') }                     </pre>

**Table 7 — Mapping table for toolpath UoF (continued)**

Application element	AIM element	Source	Rules	Reference path
<p>its_direction</p> <p>#1: if value is true (mapping may also be omitted if value is true)</p> <p>#2: if value is false</p>	<p>descriptive_representation_item</p>	<p>10303-45</p>		<pre> machining_toolpath &lt;=   action_method characterized_action_definition = action_method characterized_action_definition &lt;-   action_property_definition { action_property.name = 'direction' }   action_property &lt;- action_property_representation.property action_property_representation action_property_representation.representation -&gt;   representation   representation.items[i] -&gt;   representation_item =&gt;   descriptive_representation_item   descriptive_representation_item.description { #1: (descriptive_representation_item.description = \   'beginning to end' ) #2: (descriptive_representation_item.description = \   'end to beginning' ) }</pre>

**Table 7 — Mapping table for toolpath UoF (continued)**

Application element	AIM element	Source	Rules	Reference path
<p>its_material_removal_depth</p> <p>#1: if the depth value is described as a constant length</p> <p>#2: if the depth value is described as a curve specifying a length at each point along the toolpath.</p>	<p>(length_measure_with_unit (bounded_curve)</p>	<p>10303-41 10303-42</p>		<pre> machining_toolpath &lt;=   action_method characterized_action_definition = action_method characterized_action_definition &lt;-   action_property_definition { action_property.name = 'material removal depth' }   action_property &lt;-     action_property_representation.property   action_property_representation   action_property_representation-&gt;     representation   representation.items[i] -&gt;     #1: (representation_item =&gt;       measure_representation_item &lt;=         measure_with_unit =&gt;           length_measure_with_unit)     #2: ( representation_item =&gt;       geometric_representation_item =&gt;         curve =&gt;           bounded_curve ) </pre>

**Table 7 — Mapping table for toolpath UoF (continued)**

Application element	AIM element	Source	Rules	Reference path
<p>its_material_removal_overcut</p> <p>#1: if the overcut value is described as a constant length</p> <p>#2: if the overcut value is described as a curve specifying a length at each point along the toolpath.</p>	<p>(length_measure_with_unit (bounded_curve)</p>	<p>10303-41 10303-42</p>		<pre> machinging_toolpath &lt;=   action_method characterized_action_definition = action_method characterized_action_definition &lt;-   action_property_definition { action_property.name = 'material removal overcut' }   action_property &lt;-     action_property_representation.property   action_property_representation   action_property_representation   action_property_representation.representation -&gt;     representation     representation.items[i] -&gt;       #1: (representation_item =&gt;         measure_representation_item &lt;=           measure_with_unit =&gt;             length_measure_with_unit)       #2: ( representation_item =&gt;         geometric_representation_item =&gt;           curve =&gt;             bounded_curve )           </pre>

**Table 7 — Mapping table for toolpath UoF (continued)**

Application element	AIM element	Source	Rules	Reference path
its_material_removal_total_volume	measure_with_unit	10303-41		<pre> machinging_toolpath &lt;=   action_method characterized_action_definition = action_method characterized_action_definition &lt;-   action_property_definition { action_property.name = 'material removal total volume' }   action_property &lt;-   action_property_representation.property   action_property_representation   action_property_representation.representation -&gt;   representation   representation.items[i] -&gt;   representation_item =&gt;   measure_representation_item &lt;=   measure_with_unit   { measure_with_unit.value_component -&gt;   measure_value   measure_value = volume_measure   volume_measure } </pre>

Table 8 — Mapping table for process data for milling UoF

Application element	AIM element	Source	Rules	Reference path
ADAPTIVE_CONTROL	machining_technology	10303-238		machining_technology <= action_method { action_method.description = 'adaptive control' }
AIR_STRATEGY	machining_approach_retract_strategy	10303-238		machining_approach_retract_strategy <= machining_strategy <= action_method { {action_method.description = 'approach retract angle' (action_method.description = 'approach retract tangent') } }
ALONG_PATH	machining_approach_retract_strategy	10303-238		machining_approach_retract_strategy <= machining_strategy <= action_method { action_method.description = 'along path' }
along_path to toolpath (as path) See NOTE 19	PATH			machining_approach_retract_strategy <= machining_strategy <= action_method <= action_method.relationship.relatng_method { action_method.relationship => machining_toolpath_sequence_relationship } action_method.relationship.related_method -> action_method => machining_toolpath
AP_RETRACT_ANGLE	machining_approach_retract_strategy	10303-238		machining_approach_retract_strategy <= machining_strategy <= action_method { action_method.description = 'approach retract angle' }

**Table 8 — Mapping table for process data for milling UoF (continued)**

Application element	AIM element	Source	Rules	Reference path
angle	plane_angle_measure_with_unit	10303-41		<pre> machining_approach_retract_strategy &lt;=   machining_strategy &lt;=     action_method characterized_action_definition = action_method characterized_action_definition &lt;-   action_property.definition { action_property.name = 'travel angle' }   action_property &lt;- action_property_representation.property action_property_representation action_property_representation.representation -&gt;   representation representation.items[i] -&gt;   representation_item =&gt; measure_representation_item &lt;=   measure_with_unit =&gt; plane_angle_measure_with_unit </pre>
travel_length	length_measure_with_unit	10303-41		<pre> machining_approach_retract_strategy &lt;=   machining_strategy &lt;=     action_method characterized_action_definition = action_method characterized_action_definition &lt;-   action_property.definition { action_property.name = 'travel length' }   action_property &lt;- action_property_representation.property action_property_representation action_property_representation.representation -&gt;   representation representation.items[i] -&gt;   representation_item =&gt; measure_representation_item &lt;=   measure_with_unit =&gt; length_measure_with_unit </pre>



**Table 8 — Mapping table for process data for milling UoF (continued)**

Application element	AIM element	Source	Rules	Reference path
AP_RETRACT_TANGENT	machining_approach_retract_strategy	10303-238		<pre> machining_approach_retract_strategy &lt;=   machining_strategy &lt;=     action_method   { action_method.description = 'approach retract tangent' } </pre>
radius	length_measure_with_unit	10303-41		<pre> machining_approach_retract_strategy &lt;=   machining_strategy &lt;=     action_method   characterized_action_definition = action_method   characterized_action_definition &lt;-     action_property.definition   { action_property.name = 'travel radius' }   action_property &lt;-     action_property_representation.property   action_property_representation   action_property_representation.representation -&gt;     representation   representation.items[i] -&gt;     representation_item =&gt;       measure_representation_item &lt;=         measure_with_unit =&gt;           length_measure_with_unit </pre>
APPROACH_RETRACT_STRATEGY	machining_approach_retract_strategy	10303-238		<pre> machining_approach_retract_strategy &lt;=   machining_strategy &lt;=     action_method </pre>

**Table 8 — Mapping table for process data for milling UoF (continued)**

Application element	AIM element	Source	Rules	Reference path
tool_orientation	direction	10303-42		<pre> machining_approach_retract_strategy &lt;=   machining_strategy &lt;=     action_method characterized_action_definition = action_method characterized_action_definition &lt;-   action_property.definition { action_property.name = 'tool orientation' }   action_property &lt;- action_property_representation.property action_property_representation action_property_representation.representation -&gt;   representation   representation.items[i] -&gt;   representation_item =&gt;   geometric_representation_item =&gt;     direction </pre>
BACK_BORING	back_boring_operation	10303-238		<pre> back_boring_operation &lt;= drilling_type_operation &lt;=   machining_operation &lt;=     action_method </pre>
BIDIRECTIONAL	milling_type_strategy	10303-238		<pre> milling_type_strategy &lt;=   machining_strategy &lt;=     action_method { action_method.description = 'bidirectional' } </pre>

**Table 8 — Mapping table for process data for milling UoF (continued)**

Application element	AIM element	Source	Rules	Reference path
feed_direction	direction	10303-42		milling_type_strategy <= machining_strategy <= action_method characterized_action_definition = action_method characterized_action_definition <- action_property.definition { action_property.name = 'feed direction' } action_property <- action_property_representation.property action_property_representation action_property_representation.representation -> representation representation.items[i] -> representation_item => geometric_representation_item => direction
stepover_direction	descriptive_representation_item.- description	10303-45		milling_type_strategy <= machining_strategy <= action_method characterized_action_definition = action_method characterized_action_definition <- action_property.definition { action_property.name = 'stepover direction' } action_property <- action_property_representation.property action_property_representation action_property_representation.representation -> representation representation.items[i] -> representation_item => descriptive_representation_item descriptive_representation_item.description { (descriptive_representation_item.description = 'left' ) (descriptive_representation_item.description = 'right' ) }

**Table 8 — Mapping table for process data for milling UoF (continued)**

Application element	AIM element	Source	Rules	Reference path
its_stroke_connection_strategy	descriptive_representation_item.-description	10303-45		<pre> milling_type_strategy &lt;= machining_strategy &lt;=   action_method characterized_action_definition = action_method characterized_action_definition &lt;-   action_property.definition { action_property.name = 'connection strategy' }   action_property &lt;-   action_property_representation.property   action_property_representation   action_property_representation.representation -&gt;   representation   representation.items[i] -&gt;   representation_item =&gt;   descriptive_representation_item   descriptive_representation_item.description { (descriptive_representation_item.description = 'straight line' ) (descriptive_representation_item.description = 'lift shift plunge' ) (descriptive_representation_item.description = 'degouge' ) (descriptive_representation_item.description = 'loop back' ) } </pre>
BIDIRECTIONAL_CONTOUR	milling_type_strategy	10303-238		<pre> milling_type_strategy &lt;= machining_strategy &lt;=   action_method { action_method.description = 'bidirectional contour' } </pre>

**Table 8 — Mapping table for process data for milling UoF (continued)**

Application element	AIM element	Source	Rules	Reference path
feed_direction	direction	10303-42		milling_type_strategy <= machining_strategy <= action_method characterized_action_definition = action_method characterized_action_definition <- action_property.definition { action_property.name = 'feed direction' } action_property <- action_property_representation.property action_property_representation action_property_representation.representation -> representation representation.items[i] -> representation_item => geometric_representation_item => direction
stepover_direction	descriptive_representation_item.- description	10303-45		milling_type_strategy <= machining_strategy <= action_method characterized_action_definition = action_method characterized_action_definition <- action_property.definition { action_property.name = 'stepover direction' } action_property <- action_property_representation.property action_property_representation action_property_representation.representation -> representation representation.items[i] -> representation_item => descriptive_representation_item descriptive_representation_item.description { (descriptive_representation_item.description = 'left' ) (descriptive_representation_item.description = 'right' ) }

**Table 8 — Mapping table for process data for milling UoF (continued)**

Application element	AIM element	Source	Rules	Reference path
rotation_direction	descriptive_representation_item.description	10303-45		<pre> milling_type_strategy &lt;= machining_strategy &lt;= action_method characterized_action_definition = action_method characterized_action_definition &lt;- action_property.definition { action_property.name = 'rotation direction' } action_property &lt;- action_property_representation.property action_property_representation action_property_representation.representation -&gt; representation representation.items[i] -&gt; representation_item =&gt; descriptive_representation_item descriptive_representation_item.description { (descriptive_representation_item.description = \ 'clockwise' ) } (descriptive_representation_item.description = \ 'counterclockwise' ) }                     </pre>

**Table 8 — Mapping table for process data for milling UoF (continued)**

Application element	AIM element	Source	Rules	Reference path
spiral_cutmode	descriptive_representation_item.-description	10303-45		milling_type_strategy <= machining_strategy <= action_method characterized_action_definition = action_method characterized_action_definition <- action_property.definition { action_property.name = 'spiral cutmode' } action_property <- action_property_representation.property action_property_representation action_property_representation.representation -> representation representation.items[i] -> representation_item => descriptive_representation_item descriptive_representation_item.description { (descriptive_representation_item.description = 'climb' ) (descriptive_representation_item.description = 'conventional' ) }
BORING	boring_operation	10303-238		boring_operation <= drilling_type_operation <= machining_operation <= action_method { action_method.description = 'boring' }
BORING_OPERATION	boring_operation	10303-238		boring_operation <= drilling_type_operation <= machining_operation <= action_method

**Table 8 — Mapping table for process data for milling UoF (continued)**

Application element	AIM element	Source	Rules	Reference path
<p>spindle_stop_at_bottom</p> <p>#1: if value is true</p> <p>#2: if value is false (mapping may also be omitted if value is false)</p>	<p>descriptive_representation_item.-description</p>	<p>10303-45</p>		<pre> boring_operation &lt;= drilling_type_operation &lt;= machining_operation &lt;= action_method characterized_action_definition = action_method characterized_action_definition &lt;- action_property.definition { action_property.name = 'spindle stop' } action_property &lt;- action_property_representation.property action_property_representation action_property_representation.representation -&gt; representation representation.items[] -&gt; representation_item =&gt; descriptive_representation_item descriptive_representation_item.description { #1: (descriptive_representation_item.description = \ 'spindle stop at bottom' ) #2: (descriptive_representation_item.description = \ 'spindle nonstop' ) }                     </pre>



**Table 8 — Mapping table for process data for milling UoF (continued)**

Application element	AIM element	Source	Rules	Reference path
depth_of_testcut	length_measure_with_unit	10303-41		boring_operation <= drilling_type_operation <= machining_operation <= action_method characterized_action_definition = action_method characterized_action_definition <= action_property.definition { action_property.name = 'testcut depth' } action_property <= action_property_representation.property action_property_representation action_property_representation.representation -> representation representation.items[] -> representation_item => measure_representation_item <= measure_with_unit => length_measure_with_unit

**Table 8 — Mapping table for process data for milling UoF (continued)**

Application element	AIM element	Source	Rules	Reference path
waiting_position	cartesian_point	10303-42		boring_operation <= drilling_type_operation <= machining_operation <= action_method characterized_action_definition = action_method characterized_action_definition <- action_property.definition { action_property.name = 'waiting position' } action_property <- action_property_representation.property action_property_representation action_property_representation.representation -> representation representation.items[] -> representation_item => geometric_representation_item => point => cartesian_point
BOTTOM_AND_SIDE_FINISH_- MILLING	bottom_and_side_milling_operation	10303-238		bottom_and_side_milling_operation <= milling_type_operation <= machining_operation <= action_method { action_method.description = 'finishing' }
BOTTOM_AND_SIDE_MILLING	bottom_and_side_milling_operation	10303-238		bottom_and_side_milling_operation <= milling_type_operation <= machining_operation <= action_method

**Table 8 — Mapping table for process data for milling UoF (continued)**

Application element	AIM element	Source	Rules	Reference path
axial_cutting_depth	length_measure_with_unit	10303-41		<pre> bottom_and_side_milling_operation &lt;=   milling_type_operation &lt;=     machining_operation &lt;=       action_method characterized_action_definition = action_method characterized_action_definition &lt;-   action_property.definition { action_property.name = 'axial cutting depth' }   action_property &lt;-     action_property_representation.property   action_property_representation action_property_representation.representation -&gt;   representation   representation.items[] -&gt;     representation_item =&gt;       measure_representation_item &lt;=         measure_with_unit =&gt;           length_measure_with_unit </pre>

**Table 8 — Mapping table for process data for milling UoF (continued)**

Application element	AIM element	Source	Rules	Reference path
radial_cutting_depth	length_measure_with_unit	10303-41		<pre> bottom_and_side_milling_operation &lt;=   milling_type_operation &lt;=     machining_operation &lt;=       action_method characterized_action_definition = action_method characterized_action_definition &lt;-   action_property.definition { action_property.name = 'radial cutting depth' }   action_property &lt;-     action_property_representation.property   action_property_representation action_property_representation.representation -&gt;   representation   representation.items[i] -&gt;     representation_item =&gt;       measure_representation_item &lt;=         measure_with_unit =&gt;           length_measure_with_unit                     </pre>

**Table 8 — Mapping table for process data for milling UoF (continued)**

Application element	AIM element	Source	Rules	Reference path
allowance_side	length_measure_with_unit	10303-41		<pre> bottom_and_side_milling_operation &lt;=   milling_type_operation &lt;=   machining_operation &lt;=   action_method characterized_action_definition = action_method characterized_action_definition &lt;-   action_property.definition { action_property.name = 'allowance side' }   action_property &lt;-   action_property_representation.property   action_property_representation   action_property_representation.representation -&gt;   representation   representation.items[] -&gt;   representation_item =&gt;   measure_representation_item &lt;=   measure_with_unit =&gt;   length_measure_with_unit                     </pre>

**Table 8 — Mapping table for process data for milling UoF (continued)**

Application element	AIM element	Source	Rules	Reference path
allowance_bottom	length_measure_with_unit	10303-41		<pre> bottom_and_side_milling_operation &lt;=   milling_type_operation &lt;=   machining_operation &lt;=   action_method characterized_action_definition = action_method characterized_action_definition &lt;-   action_property.definition   { action_property.name = 'allowance bottom' }   action_property &lt;-   action_property_representation.property   action_property_representation   action_property_representation.representation -&gt;   representation   representation.items[] -&gt;   representation_item =&gt;   measure_representation_item &lt;=   measure_with_unit =&gt;   length_measure_with_unit                     </pre>
BOTTOM_AND_SIDE_ROUGH_MILLING	bottom_and_side_milling_operation	10303-238		<pre> bottom_and_side_milling_operation &lt;=   milling_type_operation &lt;=   machining_operation &lt;=   action_method   { action_method.description = 'roughing' }                     </pre>
CENTER_DRILLING	drilling_operation	10303-238		<pre> drilling_operation &lt;=   drilling_type_operation &lt;=   machining_operation &lt;=   action_method   { action_method.description = 'center drilling' }                     </pre>
CENTER_MILLING	milling_type_strategy	10303-238		<pre> milling_type_strategy &lt;=   machining_strategy &lt;=   action_method   { action_method.description = 'center milling' }                     </pre>

**Table 8 — Mapping table for process data for milling UoF (continued)**

Application element	AIM element	Source	Rules	Reference path
CONTOUR_BIDIRECTIONAL	milling_type_strategy	10303-238		<pre> milling_type_strategy &lt;= maching_strategy &lt;= action_method { action_method.description = 'contour bidirectional' } </pre>
feed_direction	direction	10303-42		<pre> milling_type_strategy &lt;= maching_strategy &lt;= action_method characterized_action_definition = action_method characterized_action_definition &lt;- action_property.definition { action_property.name = 'feed direction' } action_property &lt;- action_property_representation.property action_property_representation action_property_representation.representation -&gt; representation representation.items[i] -&gt; representation_item =&gt; geometric_representation_item =&gt; direction </pre>

**Table 8 — Mapping table for process data for milling UoF (continued)**

Application element	AIM element	Source	Rules	Reference path
stepover_direction	descriptive_representation_item.-description	10303-45		<pre> milling_type_strategy &lt;= machining_strategy &lt;= action_method characterized_action_definition = action_method characterized_action_definition &lt;- action_property.definition { action_property.name = 'stepover direction' } action_property &lt;- action_property_representation.property action_property_representation action_property_representation.representation -&gt; representation representation.items[i] -&gt; representation_item =&gt; descriptive_representation_item descriptive_representation_item.description { (descriptive_representation_item.description = 'left' ) (descriptive_representation_item.description = 'right' ) }                     </pre>



**Table 8 — Mapping table for process data for milling UoF (continued)**

Application element	AIM element	Source	Rules	Reference path
rotation_direction	descriptive_representation_item.description	10303-45		<pre> milling_type_strategy &lt;= machining_strategy &lt;= action_method characterized_action_definition = action_method characterized_action_definition &lt;- action_property.definition { action_property.name = 'rotation direction' } action_property &lt;- action_property_representation.property action_property_representation action_property_representation.representation -&gt; representation representation.items[i] -&gt; representation_item =&gt; descriptive_representation_item descriptive_representation_item.description { (descriptive_representation_item.description = \ 'clockwise' ) (descriptive_representation_item.description = \ 'counterclockwise' ) }                     </pre>

**Table 8 — Mapping table for process data for milling UoF (continued)**

Application element	AIM element	Source	Rules	Reference path
spiral_cutmode	descriptive_representation_item.-description	10303-45		<pre> milling_type_strategy &lt;= machining_strategy &lt;=   action_method characterized_action_definition = action_method characterized_action_definition &lt;-   action_property.definition   { action_property.name = 'spiral cutmode' }   action_property &lt;- action_property_representation.property action_property_representation action_property_representation.representation -&gt;   representation   representation.items[i] -&gt;   representation_item =&gt;   descriptive_representation_item   descriptive_representation_item.description   { (descriptive_representation_item.description = 'climb' ) (descriptive_representation_item.description = 'conventional' ) } </pre>
CONTOUR_PARALLEL	milling_type_strategy	10303-238		<pre> milling_type_strategy &lt;= machining_strategy &lt;=   action_method   { action_method.description = 'contour parallel' } </pre>

**Table 8 — Mapping table for process data for milling UoF (continued)**

Application element	AIM element	Source	Rules	Reference path
rotation_direction	descriptive_representation_item.description	10303-45		<pre> milling_type_strategy &lt;= machining_strategy &lt;= action_method characterized_action_definition = action_method characterized_action_definition &lt;- action_property.definition { action_property.name = 'rotation direction' } action_property &lt;- action_property_representation.property action_property_representation action_property_representation.representation -&gt; representation representation.items[i] -&gt; representation_item =&gt; descriptive_representation_item descriptive_representation_item.description { (descriptive_representation_item.description = \ 'clockwise' ) (descriptive_representation_item.description = \ 'counterclockwise' ) }</pre>

**Table 8 — Mapping table for process data for milling UoF (continued)**

Application element	AIM element	Source	Rules	Reference path
cutmode	descriptive_representation_item.-description	10303-45		<pre> milling_type_strategy &lt;= machining_strategy &lt;=   action_method characterized_action_definition = action_method characterized_action_definition &lt;-   action_property.definition { action_property.name = 'cutmode' }   action_property &lt;- action_property_representation.property action_property_representation action_property_representation.representation -&gt;   representation   representation.items[i] -&gt;   representation_item =&gt;   descriptive_representation_item   descriptive_representation_item.description { (descriptive_representation_item.description = 'climb' ) (descriptive_representation_item.description = 'conventional' ) } </pre>
CONTOUR_SPIRAL	milling_type_strategy	10303-238		<pre> milling_type_strategy &lt;= machining_strategy &lt;=   action_method { action_method.description = 'contour spiral' } </pre>

**Table 8 — Mapping table for process data for milling UoF (continued)**

Application element	AIM element	Source	Rules	Reference path
rotation_direction	descriptive_representation_item.description	10303-45		<pre> milling_type_strategy &lt;= machining_strategy &lt;= action_method characterized_action_definition = action_method characterized_action_definition &lt;- action_property.definition { action_property.name = 'rotation direction' } action_property &lt;- action_property_representation.property action_property_representation action_property_representation.representation -&gt; representation representation.items[i] -&gt; representation_item =&gt; descriptive_representation_item descriptive_representation_item.description { (descriptive_representation_item.description = \ 'clockwise' ) } (descriptive_representation_item.description = \ 'counterclockwise' ) }</pre>

**Table 8 — Mapping table for process data for milling UoF (continued)**

Application element	AIM element	Source	Rules	Reference path
cutmode	descriptive_representation_item.-description	10303-45		<pre> milling_type_strategy &lt;= machining_strategy &lt;=   action_method characterized_action_definition = action_method characterized_action_definition &lt;-   action_property.definition   { action_property.name = 'cutmode' }   action_property &lt;- action_property_representation.property action_property_representation action_property_representation.representation -&gt;   representation   representation.items[i] -&gt;   representation_item =&gt;   descriptive_representation_item   descriptive_representation_item.description   { (descriptive_representation_item.description = 'climb' ) (descriptive_representation_item.description = 'conventional' ) } </pre>
COUNTER_SINKING	drilling_operation	10303-238		<pre> drilling_operation &lt;= drilling_type_operation &lt;= machining_operation &lt;=   action_method   { action_method.description = 'counter sinking' } </pre>
DRILLING	drilling_operation	10303-238		<pre> drilling_operation &lt;= drilling_type_operation &lt;= machining_operation &lt;=   action_method   { action_method.description = 'drilling' } </pre>
DRILLING_OPERATION	drilling_operation	10303-238		<pre> drilling_operation &lt;= drilling_type_operation &lt;= machining_operation &lt;=   action_method </pre>

**Table 8 — Mapping table for process data for milling UoF (continued)**

Application element	AIM element	Source	Rules	Reference path
DRILLING_TYPE_OPERATION	drilling_type_operation	10303-238		drilling_type_operation <= machining_operation <= action_method
cutting_depth	length_measure_with_unit	10303-41		drilling_type_operation <= machining_operation <= action_method characterized_action_definition = action_method characterized_action_definition <= action_property.definition { action_property.name = 'cutting depth' } action_property <= action_property_representation.property action_property_representation action_property_representation.representation -> representation representation.items[i] -> representation_item => measure_representation_item <= measure_with_unit => length_measure_with_unit

**Table 8 — Mapping table for process data for milling UoF (continued)**

Application element	AIM element	Source	Rules	Reference path
previous_diameter	length_measure_with_unit	10303-41		<pre> drilling_type_operation &lt;= machining_operation &lt;=   action_method characterized_action_definition = action_method characterized_action_definition &lt;-   action_property.definition { action_property.name = 'previous diameter' }   action_property &lt;-   action_property_representation.property   action_property_representation   action_property_representation.representation -&gt;   representation   representation.items[i] -&gt;   representation_item =&gt;   measure_representation_item &lt;=   measure_with_unit =&gt;   length_measure_with_unit                     </pre>



**Table 8 — Mapping table for process data for milling UoF (continued)**

Application element	AIM element	Source	Rules	Reference path
dwell_time_bottom	time_measure_with_unit	10303-41		<pre> drilling_type_operation &lt;= machining_operation &lt;=   action_method characterized_action_definition = action_method characterized_action_definition &lt;-   action_property.definition { action_property.name = 'dwell time bottom' }   action_property &lt;-   action_property_representation.property   action_property_representation   action_property_representation.representation -&gt;     { representation =&gt;       machining_dwell_time_representation }       representation     { representation.name = 'dwell time' }       representation.items[i] -&gt;     { representation_item.name = 'dwell time' }       representation_item =&gt;       measure_representation_item &lt;=       measure_with_unit =&gt;       time_measure_with_unit                     </pre>

**Table 8 — Mapping table for process data for milling UoF (continued)**

Application element	AIM element	Source	Rules	Reference path
feed_on_retract	ratio_measure_with_unit	10303-41		<pre> drilling_type_operation &lt;= machining_operation &lt;= action_method characterized_action_definition = action_method characterized_action_definition &lt;- action_property.definition { action_property.name = 'feedrate on retract' } action_property &lt;- action_property_representation.property action_property_representation action_property_representation.representation -&gt; { representation =&gt; machining_feed_speed_representation } representation { representation.name = 'relative speed' } representation.items[i] -&gt; { representation_item.name = 'relative speed' } representation_item =&gt; measure_representation_item &lt;= measure_with_unit =&gt; ratio_measure_with_unit                     </pre>
drilling_type_operation to drilling_type_strategy (as its_machining_strategy)	PATH			<pre> drilling_type_operation &lt;= machining_operation &lt;= action_method &lt;- action_method_relationship.relatng_method action_method_relationship { action_method_relationship =&gt; machining_strategy_relationship } machining_strategy_relationship } { action_method_relationship.name = 'machining' } action_method_relationship.related_method -&gt; action_method =&gt; machining_strategy =&gt; drilling_type_strategy                     </pre>

**Table 8 — Mapping table for process data for milling UoF (continued)**

Application element	AIM element	Source	Rules	Reference path
DRILLING_TYPE_STRATEGY	drilling_type_strategy	10303-238		drilling_type_strategy <= machining_strategy <= action_method
reduced_cut_at_start	ratio_measure_with_unit	10303-41		drilling_type_strategy <= machining_strategy <= action_method characterized_action_definition = action_method characterized_action_definition <- action_property.definition { action_property.name = 'reduced cut at start' } action_property <- action_property_representation.property action_property_representation action_property_representation.representation -> { representation => machining_spindle_speed_representation } representation { representation.name = 'relative speed' } representation.items[j] -> { representation_item.name = 'relative speed' } representation_item => measure_representation_item <= measure_with_unit => ratio_measure_with_unit

**Table 8 — Mapping table for process data for milling UoF (continued)**

Application element	AIM element	Source	Rules	Reference path
reduced_feed_at_start	ratio_measure_with_unit	10303-41		<pre> drilling_type_strategy &lt;= machining_strategy &lt;=   action_method characterized_action_definition = action_method characterized_action_definition &lt;-   action_property.definition { action_property.name = 'reduced feedrate at start' }   action_property &lt;-   action_property_representation.property   action_property_representation   action_property_representation.representation -&gt;   { representation =&gt;     machining_feed_speed_representation }   representation   { representation.name = 'relative speed' }   representation.items[i] -&gt;   { representation_item.name = 'relative speed' }   representation_item =&gt;   measure_representation_item &lt;=   measure_with_unit =&gt;   ratio_measure_with_unit                     </pre>

**Table 8 — Mapping table for process data for milling UoF (continued)**

Application element	AIM element	Source	Rules	Reference path
depth_of_start	length_measure_with_unit	10303-41		drilling_type_strategy <= machining_strategy <= action_method characterized_action_definition = action_method characterized_action_definition <- action_property.definition { action_property.name = 'depth of start' } action_property <- action_property_representation.property action_property_representation action_property_representation.representation -> representation representation.items[i] -> representation_item => measure_representation_item <= measure_with_unit => length_measure_with_unit

**Table 8 — Mapping table for process data for milling UoF (continued)**

Application element	AIM element	Source	Rules	Reference path
reduced_cut_at_end	ratio_measure_with_unit	10303-41		<pre> drilling_type_strategy &lt;= machining_strategy &lt;=   action_method characterized_action_definition = action_method characterized_action_definition &lt;-   action_property.definition { action_property.name = 'reduced cut at end' }   action_property &lt;-   action_property_representation.property   action_property_representation   action_property_representation.representation -&gt;     { representation =&gt;       machining_spindle_speed_representation }     representation     { representation.name = 'relative speed' }     representation.items[i] -&gt;     { representation_item.name = 'relative speed' }       representation_item =&gt;       measure_representation_item &lt;=       measure_with_unit =&gt;       ratio_measure_with_unit                     </pre>

**Table 8 — Mapping table for process data for milling UoF (continued)**

Application element	AIM element	Source	Rules	Reference path
reduced_feed_at_end	ratio_measure_with_unit	10303-41		<pre> drilling_type_strategy &lt;= machining_strategy &lt;= action_method characterized_action_definition = action_method characterized_action_definition &lt;- action_property.definition { action_property.name = 'reduced feedrate at end' } action_property &lt;- action_property_representation.property action_property_representation action_property_representation.representation -&gt; { representation =&gt; machining_feed_speed_representation } representation { representation.name = 'relative speed' } representation.items[i] -&gt; { representation_item.name = 'relative speed' } representation_item =&gt; measure_representation_item &lt;= measure_with_unit =&gt; ratio_measure_with_unit                     </pre>

**Table 8 — Mapping table for process data for milling UoF (continued)**

Application element	AIM element	Source	Rules	Reference path
depth_of_end	length_measure_with_unit	10303-41		drilling_type_strategy <= machining_strategy <= action_method characterized_action_definition = action_method characterized_action_definition <- action_property.definition { action_property.name = 'depth of end' } action_property <- action_property_representation.property action_property_representation action_property_representation.representation -> representation representation.items[i] -> representation_item => measure_representation_item <= measure_with_unit => length_measure_with_unit
EXCHANGE_PALLET	machining_nc_function	10303-238		machining_nc_function <= machining_process_executable <= action_method { action_method.description = 'exchange pallet' }
EXPLICIT_STRATEGY	milling_type_strategy	10303-238		milling_type_strategy <= machining_strategy <= action_method { action_method.description = 'explicit' }
FIVE_AXES_CONST_TILT_YAW	machining_tool_direction_representation	10303-238		machining_tool_direction_representation <= representation { representation.name = 'five axes const tilt yaw' }



Table 8 — Mapping table for process data for milling UoF (continued)

Application element	AIM element	Source	Rules	Reference path
tilt_angle	plane_angle_measure_with_unit	10303-41		<pre> maching_tool_direction_representation &lt;=   representation   representation.items[i] -&gt;   { representation_item.name = 'tool direction tilt angle' }   representation_item =&gt;   measure_representation_item &lt;=   measure_with_unit =&gt;   plane_angle_measure_with_unit </pre>
yaw_angle	plane_angle_measure_with_unit	10303-41		<pre> maching_tool_direction_representation &lt;=   representation   representation.items[i] -&gt;   { representation_item.name = 'tool direction yaw angle' }   representation_item =&gt;   measure_representation_item &lt;=   measure_with_unit =&gt;   plane_angle_measure_with_unit </pre>
FIVE_AXES_VAR_TILT_YAW	maching_tool_direction_ - representation	10303-238		<pre> maching_tool_direction_representation &lt;=   representation   {representation.name = 'five axes var tilt yaw' } </pre>
FREEFORM_FINISH_MILLING	freeform_milling_operation	10303-238		<pre> freeform_milling_operation &lt;=   milling_type_operation &lt;=   machining_operation &lt;=   action_method   { action_method.description = 'finishing' } </pre>
FREEFORM_OPERATION	freeform_milling_operation	10303-238		<pre> freeform_milling_operation &lt;=   milling_type_operation &lt;=   machining_operation &lt;=   action_method </pre>

**Table 8 — Mapping table for process data for milling UoF (continued)**

Application element	AIM element	Source	Rules	Reference path
freeform_operation to freeform_strategy (as its_machining_strategy)	PATH			<pre> freeform_milling_operation &lt;= milling_type_operation &lt;= machining_operation &lt;= action_method &lt;- action_method_relationship.relatng_method action_method_relationship { action_method_relationship =&gt; machining_strategy_relationship } machining_strategy_relationship { action_method_relationship.name = 'machining' } action_method_relationship.related_method -&gt; action_method =&gt; machining_strategy =&gt; milling_type_strategy =&gt; freeform_milling_strategy                     </pre>
FREEFORM_ROUGH_MILLING	freeform_milling_operation	10303-238		<pre> freeform_milling_operation &lt;= milling_type_operation &lt;= machining_operation &lt;= action_method { action_method.description = 'roughing' }                     </pre>
FREEFORM_STRATEGY	freeform_milling_strategy	10303-238		<pre> freeform_milling_strategy &lt;= milling_type_strategy &lt;= machining_strategy &lt;= action_method                     </pre>

**Table 8 — Mapping table for process data for milling UoF (continued)**

Application element	AIM element	Source	Rules	Reference path
pathmode	descriptive_representation_item.-description	10303-45		<pre> freeform_milling_strategy &lt;= milling_type_strategy &lt;= machining_strategy &lt;= action_method characterized_action_definition = action_method characterized_action_definition &lt;- action_property.definition { action_property.name = 'pathmode' } action_property &lt;- action_property_representation.property action_property_representation action_property_representation.representation -&gt; representation representation.items[] -&gt; representation_item =&gt; descriptive_representation_item descriptive_representation_item.description { (descriptive_representation_item.description = 'forward' ) (descriptive_representation_item.description = 'zigzag' ) } </pre>

**Table 8 — Mapping table for process data for milling UoF (continued)**

Application element	AIM element	Source	Rules	Reference path
cutmode	descriptive_representation_item.-description	10303-45		<pre> freeform_milling_strategy &lt;= milling_type_strategy &lt;= machining_strategy &lt;= action_method characterized_action_definition = action_method characterized_action_definition &lt;- action_property.definition { action_property.name = 'cutmode' } action_property &lt;- action_property_representation.property action_property_representation action_property_representation.representation -&gt; representation representation.items[] -&gt; representation_item =&gt; descriptive_representation_item descriptive_representation_item.description { (descriptive_representation_item.description = 'climb' ) (descriptive_representation_item.description = 'conventional' ) }                     </pre>
freeform_strategy to tolerances (as its_milling_tolerances)	PATH			<pre> freeform_milling_strategy &lt;= milling_type_strategy &lt;= machining_strategy &lt;= action_method characterized_action_definition = action_method characterized_action_definition &lt;- action_property.definition { action_property.name = 'milling tolerances' } action_property &lt;- action_property_representation.property action_property_representation action_property_representation.representation -&gt; representation =&gt; freeform_milling_tolerance_representation                     </pre>

**Table 8 — Mapping table for process data for milling UoF (continued)**

Application element	AIM element	Source	Rules	Reference path
stepover	length_measure_with_unit	10303-41		<pre>                     freeform_milling_strategy &lt;=                     milling_type_strategy &lt;=                     machining_strategy &lt;=                     action_method                     characterized_action_definition = action_method                     characterized_action_definition &lt;-                     action_property.definition                     { action_property.name = 'stepover length' }                     action_property &lt;-                     action_property_representation.property                     action_property_representation                     action_property_representation.representation -&gt;                     representation                     representation.items[] -&gt;                     representation_item =&gt;                     measure_representation_item &lt;=                     measure_with_unit =&gt;                     length_measure_with_unit                 </pre>
INDEX_PALLET	machining_nc_function	10303-238		<pre>                     machining_nc_function &lt;=                     machining_process_executable &lt;=                     action_method                     { action_method.description = 'index pallet' }                 </pre>

**Table 8 — Mapping table for process data for milling UoF (continued)**

Application element	AIM element	Source	Rules	Reference path
its_index	count_measure	10303-41		<pre> machining_nc_function &lt;= machining_process_executable &lt;= action_method characterized_action_definition = action_method characterized_action_definition &lt;- action_property.definition { action_property.name = 'pallet index' } action_property &lt;- action_property_representation.property action_property_representation action_property_representation.representation -&gt; representation representation.items[i] -&gt; representation_item =&gt; measure_representation_item &lt;= measure_with_unit =&gt; measure_with_unit.value_component -&gt; measure_value measure_value = count_measure count_measure                     </pre>
INDEX_TABLE	machining_nc_function	10303-238		<pre> machining_nc_function &lt;= machining_process_executable &lt;= action_method { action_method.description = 'index table' }                     </pre>

**Table 8 — Mapping table for process data for milling UoF (continued)**

Application element	AIM element	Source	Rules	Reference path
its_index	count_measure	10303-41		<pre> machining_nc_function &lt;= machining_process_executable &lt;=   action_method characterized_action_definition = action_method characterized_action_definition &lt;-   action_property.definition   { action_property.name = 'table index' }   action_property &lt;- action_property_representation.property action_property_representation action_property_representation.representation -&gt;   representation   representation.items[i] -&gt;   representation_item =&gt;   measure_representation_item &lt;=   measure_with_unit =&gt;   measure_with_unit.value_component -&gt;   measure_value   measure_value = count_measure   count_measure </pre>
LEADING_LINE_STRATEGY	freeform_milling_strategy	10303-238		<pre> freeform_milling_strategy &lt;= milling_type_strategy &lt;=   machining_strategy &lt;=   action_method   { action_method.description = 'leading line' } </pre>

**Table 8 — Mapping table for process data for milling UoF (continued)**

Application element	AIM element	Source	Rules	Reference path
its_line	bounded_curve	10303-42		<pre> freeform_milling_strategy &lt;= milling_type_strategy &lt;= machining_strategy &lt;= action_method characterized_action_definition = action_method characterized_action_definition &lt;- action_property.definition { action_property.name = 'leading line' } action_property &lt;- action_property_representation.property action_property_representation action_property_representation.representation -&gt; representation representation.items[i] -&gt; representation_item =&gt; geometric_representation_item =&gt; curve =&gt; bounded_curve                     </pre>
LOAD_TOOL	machining_nc_function	10303-238		<pre> machining_nc_function &lt;= machining_process_executable &lt;= action_method { action_method.description = 'load tool' }                     </pre>
load_tool to machining_tool (as its_tool)	PATH			<pre> machining_nc_function &lt;= machining_process_executable &lt;= action_method supported_item = action_method supported_item &lt;- action_resource.usage[i] action_resource =&gt; machining_tool                     </pre>



**Table 8 — Mapping table for process data for milling UoF (continued)**

Application element	AIM element	Source	Rules	Reference path
MACHINE_AXIS_CONSTRAINT	value_range	10303-238		<pre> value_range &lt;= compound_representation_item &lt;=   representation_item   { representation_item &lt;-     representation.items[i]     representation &lt;- action_property_representation.representation action_property_representation action_property_representation.property -&gt; action_property action_property.name = 'axis constraint' } </pre>
axis_identifier	representation_item.name	10303-41		<pre> value_range &lt;= compound_representation_item &lt;=   representation_item   representation_item.name </pre>
machine_axis_constraint_to_value_range (as axis_range)	PATH			IDENTICAL MAPPING
MILLING_MACHINE_FUNCTIONS	machining_functions	10303-238		<pre> machining_functions &lt;=   action_method   { action_method.description = 'milling' } </pre>

**Table 8 — Mapping table for process data for milling UoF (continued)**

Application element	AIM element	Source	Rules	Reference path
coolant #1: if value is true #2: if value is false	descriptive_representation_item.- description	10303-45		<pre>                     machining_functions &lt;=                     action_method                     characterized_action_definition = action_method                     characterized_action_definition &lt;-                     action_property_definition                     { action_property.name = 'coolant' }                     action_property &lt;-                     action_property_representation.property                     action_property_representation                     action_property_representation.representation -&gt;                     representation                     representation.items[i] -&gt;                     representation_item =&gt;                     descriptive_representation_item                     descriptive_representation_item.description                     {#1: (descriptive_representation_item.description = 'coolant on')                     #2: (descriptive_representation_item.description = 'coolant off')} }                     </pre>

**Table 8 — Mapping table for process data for milling UoF (continued)**

Application element	AIM element	Source	Rules	Reference path
coolant_pressure	measure_with_unit	10303-41		<pre> maching_functions &lt;=   action_method characterized_action_definition = action_method characterized_action_definition &lt;-   action_property_definition { action_property.name = 'coolant pressure' }   action_property &lt;-     action_property_representation.property   action_property_representation   action_property_representation-&gt;     representation   representation.items[i] -&gt;     representation_item =&gt;       measure_representation_item &lt;=         measure_with_unit         { measure_with_unit.value_component -&gt;           measure_value           measure_value = numeric_measure           numeric_measure } </pre>

**Table 8 — Mapping table for process data for milling UoF (continued)**

Application element	AIM element	Source	Rules	Reference path
mist #1: if value is true #2: if value is false (mapping may also be omitted if value is false)	descriptive_representation_item.-description	10303-45		<pre> machining_functions &lt;=   action_method characterized_action_definition = action_method characterized_action_definition &lt;-   action_property_definition   { action_property.name = 'mist' }   action_property &lt;-     action_property_representation.property     action_property_representation     action_property_representation.representation -&gt;       representation       representation.items[i] -&gt;         representation_item =&gt;           descriptive_representation_item           descriptive_representation_item.description           { #1: (descriptive_representation_item.description = 'mist on' )             #2: (descriptive_representation_item.description = 'mist off' ) }                     </pre>

**Table 8 — Mapping table for process data for milling UoF (continued)**

Application element	AIM element	Source	Rules	Reference path
<p>through_spindle_coolant</p> <p>#1: if value is true</p> <p>#2: if value is false (mapping may also be omitted if value is false)</p>	<p>descriptive_representation_item.-description</p>	<p>10303-45</p>		<pre> maching_functions &lt;=   action_method characterized_action_definition = action_method characterized_action_definition &lt;-   action_property_definition { action_property.name = 'through spindle coolant' }   action_property &lt;-     action_property_representation.property   action_property_representation   action_property_representation.representation -&gt;     representation   representation.items[i] -&gt;     representation_item =&gt;       descriptive_representation_item       descriptive_representation_item.description { #1: (descriptive_representation_item.description = \   'through spindle coolant on' ) #2: (descriptive_representation_item.description = \   'through spindle coolant off' ) } </pre>

**Table 8 — Mapping table for process data for milling UoF (continued)**

Application element	AIM element	Source	Rules	Reference path
through_pressure	measure_with_unit	10303-41		<pre> maching_functions &lt;=   action_method characterized_action_definition = action_method characterized_action_definition &lt;-   action_property_definition { action_property.name = 'through spindle pressure' }   action_property &lt;-     action_property_representation.property   action_property_representation   action_property_representation.representation -&gt;     representation   representation.items[i] -&gt;     representation_item =&gt;       measure_representation_item &lt;=         measure_with_unit         { measure_with_unit.value_component -&gt;           measure_value           measure_value = numeric_measure           numeric_measure } </pre>

**Table 8 — Mapping table for process data for milling UoF (continued)**

Application element	AIM element	Source	Rules	Reference path
axis_clamping	descriptive_representation_item.-description	10303-45		<pre> maching_functions &lt;=   action_method characterized_action_definition = action_method characterized_action_definition &lt;-   action_property.definition { action_property.name = 'axis clamping' }   action_property &lt;-   action_property_representation.property   action_property_representation   action_property_representation.representation -&gt;   representation   representation.items[i] -&gt;   representation_item =&gt;   compound_representation_item   compound_representation_item.item_element -&gt;   compound_item_definition   compound_item_definition = list_representation_item   list_representation_item[i] -&gt;   representation_item =&gt;   descriptive_representation_item   descriptive_representation_item.description </pre>

**Table 8 — Mapping table for process data for milling UoF (continued)**

Application element	AIM element	Source	Rules	Reference path
<p>chip_removal</p> <p>#1: if value is true</p> <p>#2: if value is false (mapping may also be omitted if value is false)</p>	<p>descriptive_representation_item.- description</p>	<p>10303-45</p>		<pre> machining_functions &lt;=   action_method characterized_action_definition = action_method characterized_action_definition &lt;-   action_property_definition { action_property.name = 'chip removal' }   action_property &lt;-   action_property_representation.property   action_property_representation   action_property_representation.representation -&gt;   representation   representation.items[i] -&gt;   representation_item =&gt;   descriptive_representation_item   descriptive_representation_item.description { #1: (descriptive_representation_item.description = \ 'chip removal on' ) #2: (descriptive_representation_item.description = \ 'chip removal off' ) } </pre>
<p>oriented_spindle_stop</p>	<p>direction</p>	<p>10303-42</p>		<pre> machining_functions &lt;=   action_method characterized_action_definition = action_method characterized_action_definition &lt;-   action_property_definition { action_property.name = 'oriented spindle stop' }   action_property &lt;-   action_property_representation.property   action_property_representation   action_property_representation.representation -&gt;   representation   representation.items[i] -&gt;   representation_item =&gt;   geometric_representation_item =&gt;   direction </pre>



**Table 8 — Mapping table for process data for milling UoF (continued)**

Application element	AIM element	Source	Rules	Reference path
milling_machine_functions to process_model (as its_process_model)  See NOTE 21	PATH			<pre>                     machining_functions &lt;=                     action_method &lt;-                     action_method_relationship.relatng_method                     action_method_relationship                     { action_method_relationship =&gt;                     serial_action_method =&gt;                     sequential_method =&gt;                     machining_process_model.relationship }                     action_method_relationship.related_method -&gt;                     action_method =&gt;                     machining_process_model                     </pre>
milling_machine_functions to property_parameter (as other_functions)	PATH			<pre>                     machining_functions &lt;=                     action_method                     characterized_action_definition = action_method                     characterized_action_definition &lt;-                     action_property.definition                     { action_property.name = 'other functions' }                     action_property &lt;-                     action_property_representation.property                     action_property_representation                     action_property_representation.representation -&gt;                     representation                     representation.items[i] -&gt;                     representation_item =&gt;                     compound_representation_item                     compound_representation_item_element -&gt;                     compound_item_definition                     compound_item_definition = set representation_item                     set_representation_item[i] -&gt;                     representation_item                     </pre>

**Table 8 — Mapping table for process data for milling UoF (continued)**

Application element	AIM element	Source	Rules	Reference path
axis_constraints	value_range	10303-238		<pre> maching_functions &lt;=   action_method characterized_action_definition = action_method characterized_action_definition &lt;-   action_property_definition { action_property.name = 'axis constraint' }   action_property &lt;-   action_property_representation.property   action_property_representation   action_property_representation-&gt;   representation   representation.items[i] -&gt;   representation_item =&gt;   compound_representation_item =&gt;   value_range </pre>
MILLING_MACHINING_OPERATION	maching_operation	10303-238		<pre> maching_operation &lt;= { machining_operation =&gt; (milling_type_operation) (drilling_type_operation) }   action_method </pre>

**Table 8 — Mapping table for process data for milling UoF (continued)**

Application element	AIM element	Source	Rules	Reference path
overcut_length	length_measure_with_unit	10303-41		machining_operation <= action_method characterized_action_definition = action_method characterized_action_definition <- action_property_definition { action_property.name = 'overcut length' } action_property <- action_property_representation.property action_property_representation action_property_representation.representation -> representation representation.items[i] -> representation_item => measure_representation_item <= measure_with_unit => length_measure_with_unit
MILLING_TECHNOLOGY	machining_technology	10303-238		machining_technology <= action_method { action_method.description = 'milling' }

**Table 8 — Mapping table for process data for milling UoF (continued)**

Application element	AIM element	Source	Rules	Reference path
cutspeed	measure_with_unit	10303-41		<pre> maching_technology &lt;=   action_method characterized_action_definition = action_method characterized_action_definition &lt;-   action_property_definition { action_property.name = 'spindle' }   action_property &lt;-   action_property_representation.property   action_property_representation action_property_representation.representation -&gt; { representation =&gt;   machining_spindle_speed_representation }   representation { representation.name = 'cutting speed' }   representation.items[i] -&gt; { representation_item.name = 'surface speed' }   representation_item =&gt;   measure_representation_item &lt;=   measure_with_unit { measure_with_unit.value_component -&gt;   measure_value   measure_value = numeric_measure   numeric_measure } </pre>

**Table 8 — Mapping table for process data for milling UoF (continued)**

Application element	AIM element	Source	Rules	Reference path
spindle	measure_with_unit	10303-41		<pre> machining_technology &lt;=   action_method characterized_action_definition = action_method characterized_action_definition &lt;-   action_property_definition { action_property.name = 'spindle' }   action_property &lt;-     action_property_representation.property   action_property_representation   action_property_representation-&gt;     { representation =&gt;       machining_spindle_speed_representation }       representation     { representation.name = 'spindle speed' }       representation.items[i] -&gt;     { representation_item.name = 'rotational speed' }       representation_item =&gt;         measure_representation_item &lt;=           measure_with_unit         measure_value         { measure_with_unit.value_component -&gt;           measure_value = numeric_measure             numeric_measure } </pre>

**Table 8 — Mapping table for process data for milling UoF (continued)**

Application element	AIM element	Source	Rules	Reference path
feedrate_per_tooth	length_measure_with_unit	10303-41		<pre> machining_technology &lt;=   action_method characterized_action_definition = action_method characterized_action_definition &lt;-   action_property_definition { action_property.name = 'feedrate' }   action_property &lt;-     action_property_representation.property   action_property_representation   action_property_representation action_property_representation.representation -&gt;   { representation =&gt;     machining_feed_speed_representation }     representation   { representation.name = 'feed per tooth' }   representation.items[i] -&gt;   { representation_item.name = 'feed per tooth' }     representation_item =&gt;       measure_representation_item &lt;=         measure_with_unit =&gt;           length_measure_with_unit </pre>

**Table 8 — Mapping table for process data for milling UoF (continued)**

Application element	AIM element	Source	Rules	Reference path
<p>synchronize_spindle_with_feed</p> <p>#1: if value is true</p> <p>#2: if value is false (mapping may also be omitted if value is false)</p>	<p>descriptive_representation_item.-description</p>	<p>10303-45</p>		<pre> maching_technology &lt;=   action_method characterized_action_definition = action_method characterized_action_definition &lt;-   action_property_definition { action_property.name = 'synchronize spindle with feed' }   action_property &lt;-     action_property_representation.property   action_property_representation   action_property_representation.representation -&gt;     representation   representation.items[i] -&gt;     representation_item =&gt;       descriptive_representation_item   descriptive_representation_item.description   {#1: (descriptive_representation_item.description = \     'synchronized' )     #2: (descriptive_representation_item.description = \     'not synchronized' ) }</pre>

**Table 8 — Mapping table for process data for milling UoF (continued)**

Application element	AIM element	Source	Rules	Reference path
<p>inhibit_feedrate_override</p> <p>#1: if value is true</p> <p>#2: if value is false (mapping may also be omitted if value is false)</p>	<p>descriptive_representation_item.-description</p>	<p>10303-45</p>		<pre> machining_technology &lt;=   action_method characterized_action_definition = action_method characterized_action_definition &lt;-   action_property_definition { action_property.name = 'inhibit feedrate override' }   action_property &lt;-     action_property_representation.property   action_property_representation   action_property_representation.representation -&gt;     representation   representation.items[i] -&gt;     representation_item =&gt;       descriptive_representation_item   descriptive_representation_item.description { #1: (descriptive_representation_item.description = \   'override not allowed' )   #2: (descriptive_representation_item.description = \   'override allowed' ) } </pre>



Table 8 — Mapping table for process data for milling UoF (continued)

Application element	AIM element	Source	Rules	Reference path
inhibit_spindle_override #1: if value is true #2: if value is false (mapping may also be omitted if value is false)	descriptive_representation_item.-description	10303-45		<pre> maching_technology &lt;=   action_method characterized_action_definition = action_method characterized_action_definition &lt;-   action_property_definition { action_property.name = 'inhibit spindle override' }   action_property &lt;-   action_property_representation.property   action_property_representation   action_property_representation.related_method -&gt;   representation   representation.items[i] -&gt;   representation_item =&gt;   descriptive_representation_item   descriptive_representation_item.description { #1: (descriptive_representation_item.description = \   'override not allowed' )   #2: (descriptive_representation_item.description = \   'override allowed' ) } </pre>
milling_technology to adaptive_control (as its adaptive_control)	PATH			<pre> maching_technology &lt;=   action_method &lt;-   action_method_relationship.related_method   action_method_relationship   { action_method_relationship =&gt;   machining_adaptive_control_relationship }   action_method_relationship.related_method -&gt;   action_method =&gt;   machining_technology </pre>
MILLING_TYPE_OPERATION	milling_type_operation	10303-238		<pre> milling_type_operation &lt;=   machining_operation &lt;=   action_method </pre>

**Table 8 — Mapping table for process data for milling UoF (continued)**

Application element	AIM element	Source	Rules	Reference path
milling_type_operation to approach_retract_strategy (as approach)	PATH			milling_type_operation <= machining_operation <= action_method <- action_method_relationship.relatiing_method action_method_relationship { action_method_relationship => machining_strategy_relationship } { action_method_relationship.name = 'approach' } action_method_relationship.related_method -> action_method => machining_strategy => machining_approach_retract_strategy
milling_type_operation to approach_retract_strategy (as retract)	PATH			milling_type_operation <= machining_operation <= action_method <- action_method_relationship.relatiing_method action_method_relationship { action_method_relationship => machining_strategy_relationship } { action_method_relationship.name = 'retract' } action_method_relationship.related_method -> action_method => machining_strategy => machining_approach_retract_strategy
MULTISTEP_DRILLING	drilling_operation	10303-238		drilling_operation <= drilling_type_operation <= machining_operation <= action_method { action_method.description = 'multistep drilling' }

**Table 8 — Mapping table for process data for milling UoF (continued)**

Application element	AIM element	Source	Rules	Reference path
retract_distance	length_measure_with_unit	10303-41		<pre> drilling_operation &lt;= drilling_type_operation &lt;= machining_operation &lt;= action_method characterized_action_definition = action_method characterized_action_definition &lt;- action_property.definition { action_property.name = 'retract distance' } action_property &lt;- action_property_representation.property action_property_representation action_property_representation.representation -&gt; representation representation.items[] -&gt; representation_item =&gt; measure_representation_item &lt;= measure_with_unit =&gt; length_measure_with_unit                     </pre>

**Table 8 — Mapping table for process data for milling UoF (continued)**

Application element	AIM element	Source	Rules	Reference path
first_depth	length_measure_with_unit	10303-41		<pre> drilling_operation &lt;= drilling_type_operation &lt;= machining_operation &lt;= action_method characterized_action_definition = action_method characterized_action_definition &lt;- action_property.definition { action_property.name = 'first depth' } action_property &lt;- action_property_representation.property action_property_representation action_property_representation.representation -&gt; representation representation.items[i] -&gt; representation_item =&gt; measure_representation_item &lt;= measure_with_unit =&gt; length_measure_with_unit                     </pre>

**Table 8 — Mapping table for process data for milling UoF (continued)**

Application element	AIM element	Source	Rules	Reference path
depth_of_step	length_measure_with_unit	10303-41		<pre> drilling_operation &lt;= drilling_type_operation &lt;= machining_operation &lt;= action_method characterized_action_definition = action_method characterized_action_definition &lt;- action_property.definition { action_property.name = 'depth of step' } action_property &lt;- action_property_representation.property action_property_representation action_property_representation.representation -&gt; representation representation.items[] -&gt; representation_item =&gt; measure_representation_item &lt;= measure_with_unit =&gt; length_measure_with_unit                     </pre>

**Table 8 — Mapping table for process data for milling UoF (continued)**

Application element	AIM element	Source	Rules	Reference path
dwell_time_step	time_measure_with_unit	10303-41		<pre> drilling_operation &lt;= drilling_type_operation &lt;= machining_operation &lt;= action_method characterized_action_definition = action_method characterized_action_definition &lt;- action_property.definition { action_property.name = 'dwell time step' } action_property &lt;- action_property_representation.property action_property_representation action_property_representation.representation -&gt; { representation =&gt; machining_dwell_time_representation } { representation.name = 'dwell time' } representation.items[i] -&gt; { representation_item.name = 'dwell time?' } representation_item =&gt; measure_representation_item &lt;= measure_with_unit =&gt; time_measure_with_unit </pre>
PLANE_CC_STRATEGY	freeform_milling_strategy	10303-238		<pre> freeform_milling_strategy &lt;= milling_type_strategy &lt;= machining_strategy &lt;= action_method { action_method.description = 'plane cutter contact' } </pre>

**Table 8 — Mapping table for process data for milling UoF (continued)**

Application element	AIM element	Source	Rules	Reference path
its_plane_normal	direction	10303-42		<pre> freeform_milling_strategy &lt;= milling_type_strategy &lt;= machining_strategy &lt;= action_method characterized_action_definition = action_method characterized_action_definition &lt;- action_property.definition { action_property.name = 'plane normal' } action_property &lt;- action_property_representation.property action_property_representation action_property_representation.representation -&gt; representation representation.items[i] -&gt; representation_item =&gt; geometric_representation_item =&gt; direction                     </pre>
PLANE_CL_STRATEGY	freeform_milling_strategy	10303-238		<pre> freeform_milling_strategy &lt;= milling_type_strategy &lt;= machining_strategy &lt;= action_method { action_method.description = 'plane cutter location' }                     </pre>

**Table 8 — Mapping table for process data for milling UoF (continued)**

Application element	AIM element	Source	Rules	Reference path
its_plane_normal	direction	10303-42		<pre> freeform_milling_strategy &lt;= milling_type_strategy &lt;= machining_strategy &lt;= action_method characterized_action_definition = action_method characterized_action_definition &lt;- action_property.definition { action_property.name = 'plane normal' } action_property &lt;- action_property_representation.property action_property_representation action_property_representation.representation -&gt; representation representation.items[i] -&gt; representation_item =&gt; geometric_representation_item =&gt; direction                     </pre>
PLANE_FINISH_MILLING	plane_milling_operation	10303-238		<pre> plane_milling_operation &lt;= milling_type_operation &lt;= machining_operation &lt;= action_method { action_method.description = 'finishing' }                     </pre>
PLANE_MILLING	plane_milling_operation	10303-238		<pre> plane_milling_operation &lt;= milling_type_operation &lt;= machining_operation &lt;= action_method                     </pre>



**Table 8 — Mapping table for process data for milling UoF (continued)**

Application element	AIM element	Source	Rules	Reference path
axial_cutting_depth	length_measure_with_unit	10303-41		<pre> plane_milling_operation &lt;= milling_type_operation &lt;= machining_operation &lt;= action_method characterized_action_definition = action_method characterized_action_definition &lt;- action_property.definition { action_property.name = 'axial cutting depth' } action_property &lt;- action_property_representation.property action_property_representation action_property_representation.representation -&gt; representation representation.items[] -&gt; representation_item =&gt; measure_representation_item &lt;= measure_with_unit =&gt; length_measure_with_unit                     </pre>

**Table 8 — Mapping table for process data for milling UoF (continued)**

Application element	AIM element	Source	Rules	Reference path
allowance_bottom	length_measure_with_unit	10303-41		<pre> plane_milling_operation &lt;= milling_type_operation &lt;= machining_operation &lt;= action_method characterized_action_definition = action_method characterized_action_definition &lt;- action_property.definition { action_property.name = 'allowance bottom' } action_property &lt;- action_property_representation.property action_property_representation action_property_representation.representation -&gt; representation representation.items[] -&gt; representation_item =&gt; measure_representation_item &lt;= measure_with_unit =&gt; length_measure_with_unit                     </pre>
PLANE_ROUGH_MILLING	plane_milling_operation	10303-238		<pre> plane_milling_operation &lt;= milling_type_operation &lt;= machining_operation &lt;= action_method { action_method.description = 'roughing' }                     </pre>
PLUNGE_HELIX	machining_approach_retract_strategy	10303-238		<pre> machining_approach_retract_strategy &lt;= machining_strategy &lt;= action_method { action_method.description = 'plunge helix' }                     </pre>

**Table 8 — Mapping table for process data for milling UoF (continued)**

Application element	AIM element	Source	Rules	Reference path
radius	length_measure_with_unit	10303-41		<pre> machining_approach_retract_strategy &lt;=   machining_strategy &lt;=     action_method characterized_action_definition = action_method characterized_action_definition &lt;-   action_property.definition { action_property.name = 'plunge radius' }   action_property &lt;-     action_property_representation.property   action_property_representation action_property_representation.representation -&gt;   representation   representation.items[i] -&gt;     representation_item =&gt;       measure_representation_item &lt;=         measure_with_unit =&gt;           length_measure_with_unit </pre>
angle	plane_angle_measure_with_unit	10303-41		<pre> machining_approach_retract_strategy &lt;=   machining_strategy &lt;=     action_method characterized_action_definition = action_method characterized_action_definition &lt;-   action_property.definition { action_property.name = 'plunge angle' }   action_property &lt;-     action_property_representation.property   action_property_representation action_property_representation.representation -&gt;   representation   representation.items[i] -&gt;     representation_item =&gt;       measure_representation_item &lt;=         measure_with_unit =&gt;           plane_angle_measure_with_unit </pre>

**Table 8 — Mapping table for process data for milling UoF (continued)**

Application element	AIM element	Source	Rules	Reference path
PLUNGE_RAMP	machining_approach_retract_strategy	10303-238		<pre> machining_approach_retract_strategy &lt;=   machining_strategy &lt;=     action_method   { action_method.description = 'plunge ramp' } </pre>
angle	plane_angle_measure_with_unit	10303-41		<pre> machining_approach_retract_strategy &lt;=   machining_strategy &lt;=     action_method   characterized_action_definition = action_method   characterized_action_definition &lt;-     action_property.definition   { action_property.name = 'plunge angle' }   action_property &lt;-     action_property_representation.property   action_property_representation   action_property_representation.representation -&gt;     representation   representation.items[i] -&gt;     representation_item =&gt;       measure_representation_item &lt;=         measure_with_unit =&gt;           plane_angle_measure_with_unit </pre>
PLUNGE_STRATEGY	machining_approach_retract_strategy	10303-238		<pre> machining_approach_retract_strategy &lt;=   machining_strategy &lt;=     action_method   { (action_method.description = 'plunge helix')     (action_method.description = 'plunge ramp')     (action_method.description = 'plunge toolaxis')     (action_method.description = 'plunge zigzag') } </pre>
PLUNGE_TOOLAXIS	machining_approach_retract_strategy	10303-238		<pre> machining_approach_retract_strategy &lt;=   machining_strategy &lt;=     action_method   { action_method.description = 'plunge toolaxis' } </pre>

**Table 8 — Mapping table for process data for milling UoF (continued)**

Application element	AIM element	Source	Rules	Reference path
PLUNGE_ZIGZAG	machining_approach_retract_strategy	10303-238		<pre> machining_approach_retract_strategy &lt;=   machining_strategy &lt;=     action_method     { action_method.description = 'plunge zigzag' } </pre>
angle	plane_angle_measure_with_unit	10303-41		<pre> machining_approach_retract_strategy &lt;=   machining_strategy &lt;=     action_method characterized_action_definition = action_method characterized_action_definition &lt;-   action_property.definition   { action_property.name = 'plunge angle' }   action_property &lt;-     action_property_representation.property     action_property_representation     action_property_representation.representation -&gt;       representation       representation.items[i] -&gt;         representation_item =&gt;           measure_representation_item &lt;=             measure_with_unit =&gt;               plane_angle_measure_with_unit </pre>

**Table 8 — Mapping table for process data for milling UoF (continued)**

Application element	AIM element	Source	Rules	Reference path
width	length_measure_with_unit	10303-41		machining_approach_retract_strategy <= machining_strategy <= action_method characterized_action_definition = action_method characterized_action_definition <- action_property.definition { action_property.name = 'plunge width' } action_property <- action_property_representation.property action_property_representation action_property_representation.representation -> representation representation.items[i] -> representation_item => measure_representation_item <= measure_with_unit => length_measure_with_unit
PROCESS_MODEL	machining_process_model	10303-238		machining_process_model <= action_method
ini_data_file	descriptive_representation_item	10303-45		machining_process_model <= action_method characterized_action_definition = action_method characterized_action_definition <- action_property.definition { action_property.name = 'initialization data' } action_property <- action_property_representation.property action_property_representation action_property_representation.representation -> representation representation.items[i] -> representation_item => descriptive_representation_item descriptive_representation_item.description

**Table 8 — Mapping table for process data for milling UoF (continued)**

Application element	AIM element	Source	Rules	Reference path
its_type	action_method.description	10303-49		machining_process_model <= action_method action_method.description
PROCESS_MODEL_LIST	NOT MAPPED See NOTE 21			
REAMING	boring_operation	10303-238		boring_operation <= drilling_type_operation <= machining_operation <= action_method { action_method.description = 'reaming' }
SIDE_FINISH_MILLING	side_milling_operation	10303-238		side_milling_operation <= milling_type_operation <= machining_operation <= action_method { action_method.description = 'finishing' }
SIDE_MILLING	side_milling_operation	10303-238		side_milling_operation <= milling_type_operation <= machining_operation <= action_method

**Table 8 — Mapping table for process data for milling UoF (continued)**

Application element	AIM element	Source	Rules	Reference path
axial_cutting_depth	length_measure_with_unit	10303-41		<pre> side_milling_operation &lt;= milling_type_operation &lt;= machining_operation &lt;= action_method characterized_action_definition = action_method characterized_action_definition &lt;- action_property.definition { action_property.name = 'axial cutting depth' } action_property &lt;- action_property_representation.property action_property_representation action_property_representation.representation -&gt; representation representation.items[] -&gt; representation_item =&gt; measure_representation_item &lt;= measure_with_unit =&gt; length_measure_with_unit                     </pre>



**Table 8 — Mapping table for process data for milling UoF (continued)**

Application element	AIM element	Source	Rules	Reference path
radial_cutting_depth	length_measure_with_unit	10303-41		<pre> side_milling_operation &lt;= milling_type_operation &lt;= machining_operation &lt;= action_method characterized_action_definition = action_method characterized_action_definition &lt;- action_property.definition { action_property.name = 'radial cutting depth' } action_property &lt;- action_property_representation.property action_property_representation action_property_representation.representation -&gt; representation representation.items[] -&gt; representation_item =&gt; measure_representation_item &lt;= measure_with_unit =&gt; length_measure_with_unit                     </pre>

**Table 8 — Mapping table for process data for milling UoF (continued)**

Application element	AIM element	Source	Rules	Reference path
allowance_side	length_measure_with_unit	10303-41		side_milling_operation <= milling_type_operation <= machining_operation <= action_method characterized_action_definition = action_method characterized_action_definition <- action_property.definition { action_property.name = 'allowance side' } action_property_representation.property action_property_representation action_property_representation.representation -> representation representation.items[i] -> representation_item => measure_representation_item <= measure_with_unit => length_measure_with_unit
SIDE_ROUGH_MILLING	side_milling_operation	10303-238		side_milling_operation <= milling_type_operation <= machining_operation <= action_method { action_method.description = 'roughing' }
TAPPING	tapping_operation	10303-238		tapping_operation <= drilling_type_operation <= machining_operation <= action_method { action_method.description = 'tapping' }

**Table 8 — Mapping table for process data for milling UoF (continued)**

Application element	AIM element	Source	Rules	Reference path
compensation_chuck #1: if value is true #2: if value is false (mapping may also be omitted if value is false)	descriptive_representation_item.-description	10303-45		<pre>                     tapping_operation &lt;=                     drilling_type_operation &lt;=                     machining_operation &lt;=                     action_method                     characterized_action_definition = action_method                     characterized_action_definition &lt;-                     action_property.definition                     { action_property.name = 'compensation chuck' }                     action_property &lt;-                     action_property_representation.property                     action_property_representation                     action_property_representation.representation -&gt;                     representation                     representation.items[] -&gt;                     representation_item =&gt;                     descriptive_representation_item                     descriptive_representation_item.description                     { #1: (descriptive_representation_item.description = \                     'compensation chuck used' )                     #2: (descriptive_representation_item.description = \                     'compensation chuck not used' ) }                 </pre>
THREAD_DRILLING	tapping_operation	10303-238		<pre>                     tapping_operation &lt;=                     drilling_type_operation &lt;=                     machining_operation &lt;=                     action_method                     { action_method.description = 'thread drilling' }                 </pre>

**Table 8 — Mapping table for process data for milling UoF (continued)**

Application element	AIM element	Source	Rules	Reference path
<p>helical_movement_on_forward</p> <p>#1: if value is true</p> <p>#2: if value is false (mapping may also be omitted if value is false)</p>	<p>descriptive_representation_item.-description</p>	<p>10303-45</p>		<pre>tapping_operation &lt;= drilling_type_operation &lt;= machining_operation &lt;= action_method characterized_action_definition = action_method characterized_action_definition &lt;- action_property.definition action_property &lt;- action_property_representation.property action_property_representation action_property_representation.representation -&gt; representation representation.items[i] -&gt; representation_item =&gt; descriptive_representation_item descriptive_representation_item.description { #1: (descriptive_representation_item.description = \ 'helical movement on forward' ) #2: (descriptive_representation_item.description = \ 'no helical movement on forward' ) }</pre>
<p>THREE_AXES_TILTED_TOOL</p>	<p>machining_tool_direction_-representation</p>	<p>10303-238</p>		<pre>machining_tool_direction_representation &lt;= representation {representation.name = 'three axes tilted tool' }</pre>
<p>its_tool_direction</p>	<p>direction</p>	<p>10303-42</p>		<pre>machining_tool_direction_representation &lt;= representation representation.items[i] -&gt; { representation_item.name = 'tool direction orientation' } representation_item =&gt; geometric_representation_item =&gt; direction</pre>
<p>TOLERANCES</p>	<p>freeform_milling_tolerance_-representation</p>	<p>10303-238</p>		<pre>freeform_milling_tolerance_representation &lt;= representation</pre>

**Table 8 — Mapping table for process data for milling UoF (continued)**

Application element	AIM element	Source	Rules	Reference path
chordal_tolerance	length_measure_with_unit	10303-41		<pre> freeform_milling_tolerance_representation &lt;=   representation   representation.items[i] -&gt;   { representation_item.name = 'chordal tolerance' }   representation_item =&gt;   measure_representation_item &lt;=   measure_with_unit =&gt;   length_measure_with_unit                     </pre>
scallop_height	length_measure_with_unit	10303-41		<pre> freeform_milling_tolerance_representation &lt;=   representation   representation.items[i] -&gt;   { representation_item.name = 'scallop height' }   representation_item =&gt;   measure_representation_item &lt;=   measure_with_unit =&gt;   length_measure_with_unit                     </pre>
TOOL_DIRECTION_FOR_MILLING	machining_tool_direction_ - representation	10303-238		<pre> machining_tool_direction_representation &lt;=   representation                     </pre>
TWO5D_MILLING_OPERATION	milling_type_operation	10303-238		<pre> milling_type_operation &lt;=   machining_operation &lt;=   action_method &lt;-   action_method_relationship.relatng_method   action_method_relationship   { action_method_relationship =&gt;   machining_strategy_relationship }   machining_strategy_relationship }   action_method_relationship.name = 'machining' }   action_method_relationship.related_method -&gt;   action_method =&gt;   machining_strategy =&gt;   milling_type_strategy                     </pre>
two5d_milling_operation to two5d_milling_strategy (as its_machining_strategy)	PATH			

**Table 8 — Mapping table for process data for milling UoF (continued)**

Application element	AIM element	Source	Rules	Reference path
TWO5D_MILLING_STRATEGY	milling_type_strategy	10303-238		<pre> milling_type_strategy &lt;= maching_strategy &lt;= action_method { (action_method.description = 'bidirectional') (action_method.description = 'bidirectional contour') (action_method.description = 'center milling') (action_method.description = 'contour bidirectional') (action_method.description = 'contour parallel') (action_method.description = 'contour spiral') (action_method.description = 'explicit') (action_method.description = 'unidirectional') }                     </pre>
overlap	ratio_measure_with_unit	10303-41		<pre> milling_type_strategy &lt;= maching_strategy &lt;= action_method characterized_action_definition = action_method characterized_action_definition &lt;- action_property.definition { action_property.name = 'overlap ratio' } action_property &lt;- action_property_representation.property action_property_representation action_property_representation.representation -&gt; representation representation.items[i] -&gt; representation_item =&gt; measure_representation_item &lt;= measure_with_unit =&gt; ratio_measure_with_unit                     </pre>

**Table 8 — Mapping table for process data for milling UoF (continued)**

Application element	AIM element	Source	Rules	Reference path
<p>allow_multiple_passes</p> <p>#1: if value is true (mapping may also be omitted if value is true)</p> <p>#2: if value is false</p>	<p>descriptive_representation_item.-description</p>	<p>10303-45</p>		<pre> milling_type_strategy &lt;= machining_strategy &lt;=   action_method characterized_action_definition = action_method characterized_action_definition &lt;-   action_property.definition { action_property.name = 'multiple passes' }   action_property &lt;- action_property_representation.property action_property_representation action_property_representation.representation -&gt;   representation   representation.items[i] -&gt;   representation_item =&gt;   descriptive_representation_item   descriptive_representation_item.description { #1: (descriptive_representation_item.description = \ 'multiple passes allowed' ) #2: (descriptive_representation_item.description = \ 'multiple passes not allowed' ) } </pre>
<p>UNIDIRECTIONAL</p>	<p>milling_type_strategy</p>	<p>10303-238</p>		<pre> milling_type_strategy &lt;= machining_strategy &lt;=   action_method { action_method.description = 'unidirectional' } </pre>

**Table 8 — Mapping table for process data for milling UoF (continued)**

Application element	AIM element	Source	Rules	Reference path
feed_direction	direction	10303-42		<pre> milling_type_strategy &lt;= machining_strategy &lt;= action_method characterized_action_definition = action_method characterized_action_definition &lt;- action_property.definition { action_property.name = 'feed direction' } action_property &lt;- action_property_representation.property action_property_representation action_property_representation.representation -&gt; representation representation.items[i] -&gt; representation_item =&gt; geometric_representation_item =&gt; direction                     </pre>
cutmode	descriptive_representation_item.-description	10303-45		<pre> milling_type_strategy &lt;= machining_strategy &lt;= action_method characterized_action_definition = action_method characterized_action_definition &lt;- action_property.definition { action_property.name = 'cutmode' } action_property &lt;- action_property_representation.property action_property_representation action_property_representation.representation -&gt; representation representation.items[i] -&gt; representation_item =&gt; descriptive_representation_item descriptive_representation_item.description { (descriptive_representation_item.description = 'climb' ) (descriptive_representation_item.description = 'conventional' ) }                     </pre>



**Table 8 — Mapping table for process data for milling UoF (continued)**

Application element	AIM element	Source	Rules	Reference path
UNLOAD_TOOL	machining_nc_function	10303-238		<pre>                     machining_nc_function &lt;=                     machining_process_executable &lt;=                     action_method                     { action_method.description = 'unload tool' }                 </pre>
unload_tool to machining_tool (as its_tool)	PATH			<pre>                     machining_nc_function &lt;=                     machining_process_executable &lt;=                     action_method                     supported_item = action_method                     supported_item &lt;-                     action_resource.usage[i]                     action_resource =&gt;                     machining_tool                 </pre>
UV_STRATEGY	freeform_milling_strategy	10303-238		<pre>                     freeform_milling_strategy &lt;=                     milling_type_strategy &lt;=                     machining_strategy &lt;=                     action_method                     { action_method.description = 'uv' }                 </pre>

**Table 8 — Mapping table for process data for milling UoF (continued)**

Application element	AIM element	Source	Rules	Reference path
forward_direction	direction	10303-42		<pre> freeform_milling_strategy &lt;= milling_type_strategy &lt;= machining_strategy &lt;= action_method characterized_action_definition = action_method characterized_action_definition &lt;- action_property.definition { action_property.name = 'forward direction' } action_property &lt;- action_property_representation.property action_property_representation action_property_representation.representation -&gt; representation representation.items[i] -&gt; representation_item =&gt; geometric_representation_item =&gt; direction                     </pre>
sideward_direction	direction	10303-42		<pre> freeform_milling_strategy &lt;= milling_type_strategy &lt;= machining_strategy &lt;= action_method characterized_action_definition = action_method characterized_action_definition &lt;- action_property.definition { action_property.name = 'sideward direction' } action_property &lt;- action_property_representation.property action_property_representation action_property_representation.representation -&gt; representation representation.items[i] -&gt; representation_item =&gt; geometric_representation_item =&gt; direction                     </pre>

Table 9 — Mapping table for cutting tools for milling UoF

Application element	AIM element	Source	Rules	Reference path
BALLNOSE_ENDMILL	machining_tool	10303-238		machining_tool <= action_resource { action_resource.description = 'ballnose endmill' }
BULLNOSE_ENDMILL	machining_tool	10303-238		machining_tool <= action_resource { action_resource.description = 'bullnose endmill' }
COMBINED_DRILL_AND_REAMER	machining_tool	10303-238		machining_tool <= action_resource { action_resource.description = 'combined drill and reamer' }
drill_length	length_measure_with_unit	10303-41		machining_tool <= action_resource characterized_resource_definition = action_resource characterized_resource_definition <- resource_property.resource { resource_property.name = 'tool body' } resource_property <- resource_property_representation.property resource_property_representation resource_property_representation.representation -> { representation => machining_tool_body_representation } representation representation.items[i] -> { representation_item.name = 'drill length' } representation_item => measure_representation_item <= measure_with_unit => length_measure_with_unit
COMBINED_DRILL_AND_TAP	machining_tool	10303-238		machining_tool <= action_resource { action_resource.description = 'combined drill and tap' }

**Table 9 — Mapping table for cutting tools for milling UoF (continued)**

Application element	AIM element	Source	Rules	Reference path
drill_length	length_measure_with_unit	10303-41		<pre> machining_tool &lt;=   action_resource   characterized_resource_definition = action_resource   characterized_resource_definition &lt;-     resource_property.resource   { resource_property.name = 'tool body' }   resource_property &lt;-     resource_property_representation.property   resource_property_representation   resource_property_representation.representation -&gt;     { representation =&gt;       machining_tool_body_representation }   representation   representation.items[i] -&gt;     { representation_item.name = 'drill length' }   representation_item =&gt;     measure_representation_item &lt;=       measure_with_unit =&gt;         length_measure_with_unit </pre>
COUNTERBORE	machining_tool	10303-238		<pre> machining_tool &lt;=   action_resource   { action_resource.description = 'counterbore' } </pre>
COUNTERSINK	machining_tool	10303-238		<pre> machining_tool &lt;=   action_resource   { action_resource.description = 'countersink' } </pre>

**Table 9 — Mapping table for cutting tools for milling UoF (continued)**

Application element	AIM element	Source	Rules	Reference path
minimum_cutting_diameter	length_measure_with_unit	10303-41		<pre> machining_tool &lt;=   action_resource characterized_resource_definition = action_resource characterized_resource_definition &lt;-   resource_property.resource { resource_property.name = 'tool body' } resource_property &lt;-   resource_property_representation.property resource_property_representation resource_property_representation.representation -&gt; { representation =&gt;   machining_tool_body_representation }   representation   representation.items[i] -&gt; { representation_item.name = 'minimum cutting diameter' }   representation_item =&gt;   measure_representation_item &lt;=   measure_with_unit =&gt;   length_measure_with_unit </pre>

**Table 9 — Mapping table for cutting tools for milling UoF (continued)**

Application element	AIM element	Source	Rules	Reference path
maximum_usable_length	length_measure_with_unit	10303-41		<pre> machining_tool &lt;=   action_resource characterized_resource_definition = action_resource characterized_resource_definition &lt;-   resource_property.resource { resource_property.name = 'tool body' } resource_property &lt;-   resource_property_representation.property resource_property_representation resource_property_representation.representation -&gt; { representation =&gt;   machining_tool_body_representation }   representation   representation.items[] -&gt; { representation_item.name = 'maximum usable length' }   representation_item =&gt;   measure_representation_item &lt;=   measure_with_unit =&gt;   length_measure_with_unit </pre>
CUTTING_COMPONENT	machining_cutting_component	10303-238		<pre> machining_cutting_component &lt;=   [action_resource]   [characterized_object]   { action_resource.kind -&gt;     action_resource_type     action_resource_type.name = 'milling cutting edge' } </pre>

**Table 9 — Mapping table for cutting tools for milling UoF (continued)**

Application element	AIM element	Source	Rules	Reference path
tool_functional_length	length_measure_with_unit	10303-41		<pre> machining_cutting_component &lt;=   action_resource characterized_resource_definition = action_resource characterized_resource_definition &lt;-   resource_property.resource { resource_property.name = 'functional length' } resource_property &lt;-   resource_property_representation.property resource_property_representation resource_property_representation.representation -&gt;   representation representation.items[i] -&gt;   representation_item =&gt;   measure_representation_item &lt;=   measure_with_unit =&gt;   length_measure_with_unit </pre>
cutting_component to material (as its_material)	PATH			<pre> machining_cutting_component &lt;=   characterized_object characterized_definition = characterized_object characterized_definition &lt;-   material_designation.definitions[i]   material_designation </pre>

**Table 9 — Mapping table for cutting tools for milling UoF (continued)**

Application element	AIM element	Source	Rules	Reference path
expected_tool_life	time_measure_with_unit	10303-41		<pre> maching_cutting_component &lt;=   action_resource characterized_resource_definition = action_resource characterized_resource_definition &lt;-   resource_property.resource { resource_property.name = 'expected life' } resource_property &lt;- resource_property_representation.property resource_property_representation resource_property_representation-&gt;   representation representation.items[i] -&gt;   representation_item =&gt;   measure_representation_item &lt;=   measure_with_unit =&gt;   time_measure_with_unit </pre>
cutting_component to milling_technology (as its_technology)	PATH			<pre> maching_cutting_component &lt;=   action_resource &lt;-   requirement_for_action_resource.resources[i]   requirement_for_action_resource &lt;=   action_resource_requirement   { action_resource_requirement.kind -&gt;     resource_requirement_type     resource_requirement_type.name = 'cutting component' }   action_resource_requirement.operations[i] -&gt;   characterized_action_definition   characterized_action_definition = action_method   action_method =&gt;   machining_technology </pre>
DOVETAIL_MILL	machining_tool	10303-238		<pre> machining_tool &lt;=   action_resource { action_resource.description = 'dovetail mill' } </pre>



**Table 9 — Mapping table for cutting tools for milling UoF (continued)**

Application element	AIM element	Source	Rules	Reference path
included_angle	plane_angle_measure_with_unit	10303-41		<pre> machining_tool &lt;=   action_resource   characterized_resource_definition = action_resource   characterized_resource_definition &lt;-     resource_property.resource   { resource_property.name = 'tool body' }   resource_property &lt;-     resource_property_representation.property   resource_property_representation   resource_property_representation.representation -&gt;     { representation =&gt;       machining_tool_body_representation }   representation   representation.items[i] -&gt;     { representation_item.name = 'included angle' }   representation_item =&gt;     measure_representation_item &lt;=       measure_with_unit =&gt;         plane_angle_measure_with_unit </pre>
DRILLING_CUTTING_TOOL	machining_tool	10303-238		<pre> machining_tool &lt;=   action_resource   { (action_resource.description = 'drill')     (action_resource.description = 'counterbore')     (action_resource.description = 'countersink')     (action_resource.description = 'spade drill')     (action_resource.description = 'spot drill')     (action_resource.description = 'step drill')     (action_resource.description = 'tapered drill')     (action_resource.description = 'twist drill') } </pre>

**Table 9 — Mapping table for cutting tools for milling UoF (continued)**

Application element	AIM element	Source	Rules	Reference path
point_angle	plane_angle_measure_with_unit	10303-41		<pre> machining_tool &lt;=   action_resource   characterized_resource_definition = action_resource   characterized_resource_definition &lt;-     resource_property.resource   { resource_property.name = 'tool body' }   resource_property &lt;-     resource_property_representation.property   resource_property_representation   resource_property_representation.representation -&gt;     { representation =&gt;       machining_tool_body_representation }   representation   representation.items[i] -&gt;     representation_item.name = 'point angle' }   representation_item =&gt;     measure_representation_item &lt;=       measure_with_unit =&gt;         plane_angle_measure_with_unit </pre>
ENDMILL	machining_tool	10303-238		<pre> machining_tool &lt;=   action_resource   { (action_resource.description = 'endmill')     (action_resource.description = 'ballnose endmill')     (action_resource.description = 'bullnose endmill')     (action_resource.description = 'profiled endmill') } </pre>

**Table 9 — Mapping table for cutting tools for milling UoF (continued)**

Application element	AIM element	Source	Rules	Reference path
tool_cutting_edge_angle	plane_angle_measure_with_unit	10303-41		<pre> machining_tool &lt;=   action_resource characterized_resource_definition = action_resource characterized_resource_definition &lt;-   resource_property.resource { resource_property.name = 'tool body' } resource_property &lt;-   resource_property_representation.property resource_property_representation resource_property_representation.representation -&gt; { representation =&gt;   machining_tool_body_representation }   representation   representation.items[] -&gt; { representation_item.name = 'tool cutting edge angle' }   representation_item =&gt;   measure_representation_item &lt;=   measure_with_unit =&gt;   plane_angle_measure_with_unit </pre>
FACEMILL	machining_tool	10303-238		<pre> machining_tool &lt;=   action_resource { action_resource.description = 'facemill' } </pre>

**Table 9 — Mapping table for cutting tools for milling UoF (continued)**

Application element	AIM element	Source	Rules	Reference path
tool_cutting_edge_angle	plane_angle_measure_with_unit	10303-41		<pre> machining_tool &lt;=   action_resource   characterized_resource_definition = action_resource   characterized_resource_definition &lt;-     resource_property.resource   { resource_property.name = 'tool body' }   resource_property &lt;-     resource_property_representation.property   resource_property_representation   resource_property_representation.representation -&gt;     { representation =&gt;       machining_tool_body_representation }   representation   representation.items[] -&gt;     { representation_item.name = 'tool cutting edge angle' }     representation_item =&gt;       measure_representation_item &lt;=         measure_with_unit =&gt;           plane_angle_measure_with_unit </pre>
MILLING_CUTTING_TOOL	machining_tool	10303-238		<pre> machining_tool &lt;=   action_resource   { (action_resource.description = 'ballnose endmill')     (action_resource.description = 'bullnose endmill')     (action_resource.description = 'dovetail mill')     (action_resource.description = 'endmill')     (action_resource.description = 'facemill')     (action_resource.description = 'profiled endmill')     (action_resource.description = 'shoulder mill')     (action_resource.description = 'tee slot mill')     (action_resource.description = 'thread mill')     (action_resource.description = 'side mill') } </pre>

**Table 9 — Mapping table for cutting tools for milling UoF (continued)**

Application element	AIM element	Source	Rules	Reference path
number_of_effective_teeth	count_measure	10303-41		<pre> machining_tool &lt;=   action_resource characterized_resource_definition = action_resource characterized_resource_definition &lt;-   resource_property.resource { resource_property.name = 'tool body' } resource_property &lt;-   resource_property_representation.property resource_property_representation resource_property_representation.representation -&gt; { representation =&gt;   machining_tool_body_representation } representation representation.items[i] -&gt; { representation_item.name = 'number of effective teeth' } representation_item =&gt;   measure_representation_item &lt;=   measure_with_unit =&gt;   measure_with_unit_value_component -&gt;   measure_value measure_value = count_measure count_measure </pre>

**Table 9 — Mapping table for cutting tools for milling UoF (continued)**

Application element	AIM element	Source	Rules	Reference path
edge_radius	length_measure_with_unit	10303-41		<pre> machining_tool &lt;=   action_resource characterized_resource_definition = action_resource characterized_resource_definition &lt;-   resource_property.resource { resource_property.name = 'tool body' } resource_property &lt;-   resource_property_representation.property resource_property_representation resource_property_representation-&gt;   { representation =&gt;     machining_tool_body_representation } representation representation.items[i] -&gt;   representation_item.name = 'edge radius' } representation_item =&gt;   measure_representation_item &lt;=   measure_with_unit =&gt;   length_measure_with_unit </pre>
MILLING_MACHINE_CUTTING_TOOL	machining_tool	10303-238		<pre> machining_tool &lt;=   action_resource { action_resource.kind -&gt;   action_resource_type action_resource_type.name = 'milling cutting tool' } </pre>
milling_machine_cutting_tool to cutting_component (as its_cutting_edges)	PATH			<pre> machining_tool &lt;=   action_resource &lt;- action_resource.relationship.relatng_resource action_resource_relationship action_resource_relationship.related_resource -&gt;   action_resource =&gt;   machining_cutting_component </pre>

**Table 9 — Mapping table for cutting tools for milling UoF (continued)**

Application element	AIM element	Source	Rules	Reference path
overall_assembly_length	length_measure_with_unit	10303-41		<pre> machining_tool &lt;=   action_resource characterized_resource_definition = action_resource characterized_resource_definition &lt;-   resource_property.resource { resource_property.name = 'tool body' } resource_property &lt;-   resource_property_representation.property resource_property_representation resource_property_representation.representation -&gt; { representation =&gt;   machining_tool_body_representation }   representation   representation.items[i] -&gt; { representation_item.name = 'overall assembly length' }   representation_item =&gt;   measure_representation_item &lt;=   measure_with_unit =&gt;   length_measure_with_unit </pre>

**Table 9 — Mapping table for cutting tools for milling UoF (continued)**

Application element	AIM element	Source	Rules	Reference path
effective_cutting_diameter	length_measure_with_unit	10303-41		<pre> machining_tool &lt;=   action_resource characterized_resource_definition = action_resource characterized_resource_definition &lt;-   resource_property.resource { resource_property.name = 'tool body' } resource_property &lt;-   resource_property_representation.property resource_property_representation resource_property_representation.representation -&gt; { representation =&gt;   machining_tool_body_representation }   representation   representation.items[] -&gt; { representation_item.name = 'effective cutting diameter' }   representation_item =&gt;   measure_representation_item &lt;=   measure_with_unit =&gt;   length_measure_with_unit </pre>



**Table 9 — Mapping table for cutting tools for milling UoF (continued)**

Application element	AIM element	Source	Rules	Reference path
maximum_depth_of_cut	length_measure_with_unit	10303-41		<pre> machining_tool &lt;=   action_resource characterized_resource_definition = action_resource   characterized_resource_definition &lt;-     resource_property.resource   { resource_property.name = 'tool body' }   resource_property &lt;-     resource_property_representation.property   resource_property_representation   resource_property_representation &lt;-&gt;     { representation =&gt;       machining_tool_body_representation }     representation     representation.items[i] -&gt;       { representation_item.name = 'maximum depth of cut' }       representation_item =&gt;         measure_representation_item &lt;=           measure_with_unit =&gt;             length_measure_with_unit </pre>

**Table 9 — Mapping table for cutting tools for milling UoF (continued)**

Application element	AIM element	Source	Rules	Reference path
hand_of_cut	descriptive_representation_item.-description	10303-45		<pre> machining_tool &lt;= action_resource characterized_resource_definition = action_resource characterized_resource_definition &lt;- resource_property.resource { resource_property.name = 'tool body' } resource_property &lt;- resource_property_representation.property resource_property_representation resource_property_representation.representation -&gt; { representation =&gt; machining_tool_body_representation } representation representation.items[i] -&gt; { representation_item.name = 'hand of cut' } representation_item =&gt; descriptive_representation_item descriptive_representation_item.description { (descriptive_representation_item.description = 'left' ) (descriptive_representation_item.description = 'right' ) (descriptive_representation_item.description = 'neutral' ) } </pre>

**Table 9 — Mapping table for cutting tools for milling UoF (continued)**

Application element	AIM element	Source	Rules	Reference path
coolant_through_tool	descriptive_representation_item.-description	10303-45		<pre> machining_tool &lt;=   action_resource   characterized_resource_definition = action_resource   characterized_resource_definition &lt;-     resource_property.resource   { resource_property.name = 'tool body' }   resource_property &lt;-     resource_property_representation.property   resource_property_representation   resource_property_representation.representation -&gt;     { representation =&gt;       machining_tool_body_representation }   representation   representation.items[] -&gt;     { representation_item.name = 'coolant through tool' }   representation_item =&gt;     descriptive_representation_item   descriptive_representation_item.description   { (descriptive_representation_item.description = 'supported' )     (descriptive_representation_item.description = 'not supported' ) } </pre>
PROFILED_END_MILL	machining_tool	10303-238		<pre> machining_tool &lt;=   action_resource   { action_resource.description = 'profiled endmill' } </pre>
REAMING_CUTTING_TOOL	machining_tool	10303-238		<pre> machining_tool &lt;=   action_resource   { (action_resource.description = 'reamer')     (action_resource.description = 'combined drill and reamer')     (action_resource.description = 'tapered reamer') } </pre>

**Table 9 — Mapping table for cutting tools for milling UoF (continued)**

Application element	AIM element	Source	Rules	Reference path
taper_length	length_measure_with_unit	10303-41		<pre> machining_tool &lt;= action_resource characterized_resource_definition = action_resource characterized_resource_definition &lt;- resource_property.resource { resource_property.name = 'tool body' } resource_property &lt;- resource_property_representation.property resource_property_representation resource_property_representation.representation -&gt; { representation =&gt; machining_tool_body_representation } representation representation.items[i] -&gt; { representation_item.name = 'taper length' } representation_item =&gt; measure_representation_item &lt;= measure_with_unit =&gt; length_measure_with_unit </pre>
ROTATING_BORING_CUTTING_TOOL	machining_tool	10303-238		<pre> machining_tool &lt;= action_resource { action_resource.description = 'boring tool' } </pre>

**Table 9 — Mapping table for cutting tools for milling UoF (continued)**

Application element	AIM element	Source	Rules	Reference path
retract_movement_forbidden	descriptive_representation_item.-description	10303-45		<pre> machining_tool &lt;=   action_resource characterized_resource_definition = action_resource characterized_resource_definition &lt;-   resource_property.resource { resource_property.name = 'tool body' } resource_property &lt;-   resource_property_representation.property resource_property_representation resource_property_representation.representation -&gt; { representation =&gt;   machining_tool_body_representation } representation representation.items[] -&gt; { representation_item.name = 'retract movement' } representation_item =&gt;   descriptive_representation_item descriptive_representation_item.description { (descriptive_representation_item.description = 'permitted' ) (descriptive_representation_item.description = 'forbidden' ) } </pre>
SHOULDERMILL	machining_tool	10303-238		<pre> machining_tool &lt;=   action_resource { action_resource.description = 'shoulder mill' } </pre>
SIDE_MILL	machining_tool	10303-238		<pre> machining_tool &lt;=   action_resource { action_resource.description = 'side mill' } </pre>

**Table 9 — Mapping table for cutting tools for milling UoF (continued)**

Application element	AIM element	Source	Rules	Reference path
cutter_width	length_measure_with_unit	10303-41		<pre> machining_tool &lt;= action_resource characterized_resource_definition = action_resource characterized_resource_definition &lt;- resource_property.resource { resource_property.name = 'tool body' } resource_property &lt;- resource_property_representation.property resource_property_representation resource_property_representation.representation -&gt; { representation =&gt; machining_tool_body_representation } representation representation.items[i] -&gt; { representation_item.name = 'cutter width' } representation_item =&gt; measure_representation_item &lt;= measure_with_unit =&gt; length_measure_with_unit </pre>
SPADE_DRILL	machining_tool	10303-238		<pre> machining_tool &lt;= action_resource { action_resource.description = 'spade drill' } </pre>
SPOTDRILL	machining_tool	10303-238		<pre> machining_tool &lt;= action_resource { action_resource.description = 'spot drill' } </pre>
STEP_DRILL	machining_tool	10303-238		<pre> machining_tool &lt;= action_resource { action_resource.description = 'step drill' } </pre>

**Table 9 — Mapping table for cutting tools for milling UoF (continued)**

Application element	AIM element	Source	Rules	Reference path
diameters	length_measure_with_unit	10303-41		<pre> machining_tool &lt;=   action_resource characterized_resource_definition = action_resource characterized_resource_definition &lt;-   resource_property.resource { resource_property.name = 'tool body' } resource_property &lt;-   resource_property_representation.property resource_property_representation resource_property_representation.representation -&gt; { representation =&gt;   machining_tool_body_representation }   representation   representation.items[i] -&gt; { representation_item.name = 'step diameters' }   representation_item =&gt;   compound_representation_item compound_representation_item_element -&gt;   compound_item_definition compound_item_definition = list_representation_item -&gt;   list_representation_item[i] -&gt;   representation_item =&gt;   measure_representation_item &lt;=   measure_with_unit =&gt;   length_measure_with_unit </pre>

Table 9 — Mapping table for cutting tools for milling UoF (continued)

Application element	AIM element	Source	Rules	Reference path
step_length	length_measure_with_unit	10303-41		<pre> machining_tool &lt;= action_resource characterized_resource_definition = action_resource characterized_resource_definition &lt;- resource_property.resource { resource_property.name = 'tool body' } resource_property &lt;- resource_property_representation.property resource_property_representation resource_property_representation.representation -&gt; { representation =&gt; machining_tool_body_representation } representation representation.items[i] -&gt; { representation_item.name = 'step lengths' } representation_item =&gt; compound_representation_item compound_representation_item.item_element -&gt; compound_item_definition compound_item_definition = list_representation_item list_representation_item[i] -&gt; representation_item =&gt; measure_representation_item &lt;= measure_with_unit =&gt; length_measure_with_unit </pre>
T_SLOT_MILL	machining_tool	10303-238		<pre> machining_tool &lt;= action_resource { action_resource.description = 'tee slot mill' } </pre>



**Table 9 — Mapping table for cutting tools for milling UoF (continued)**

Application element	AIM element	Source	Rules	Reference path
cutting_width	length_measure_with_unit	10303-41		<pre> machining_tool &lt;=   action_resource characterized_resource_definition = action_resource characterized_resource_definition &lt;-   resource_property.resource { resource_property.name = 'tool body' } resource_property &lt;-   resource_property_representation.property resource_property_representation resource_property_representation.representation -&gt; { representation =&gt;   machining_tool_body_representation }   representation   representation.items[i] -&gt; { representation_item.name = 'cutting width' }   representation_item =&gt;   measure_representation_item &lt;=   measure_with_unit =&gt;   length_measure_with_unit </pre>
TAPERED_DRILL	machining_tool	10303-238		<pre> machining_tool &lt;=   action_resource { action_resource.description = 'tapered drill' } </pre>

**Table 9 — Mapping table for cutting tools for milling UoF (continued)**

Application element	AIM element	Source	Rules	Reference path
taper_angle	plane_angle_measure_with_unit	10303-41		<pre> machining_tool &lt;=   action_resource   characterized_resource_definition = action_resource   characterized_resource_definition &lt;-     resource_property.resource     { resource_property.name = 'tool body' }     resource_property &lt;-       resource_property_representation.property       resource_property_representation       resource_property_representation.representation -&gt;         { representation =&gt;           machining_tool_body_representation }           representation           representation.items[i] -&gt;             { representation_item.name = 'taper angle' }             representation_item =&gt;               measure_representation_item &lt;=                 measure_with_unit =&gt;                   plane_angle_measure_with_unit </pre>
TAPERED_REAMER	machining_tool	10303-238		<pre> machining_tool &lt;=   action_resource   { action_resource.description = 'tapered reamer' } </pre>

**Table 9 — Mapping table for cutting tools for milling UoF (continued)**

Application element	AIM element	Source	Rules	Reference path
taper_angle	plane_angle_measure_with_unit	10303-41		<pre> machining_tool &lt;=   action_resource   characterized_resource_definition = action_resource   characterized_resource_definition &lt;-     resource_property.resource     { resource_property.name = 'tool body' }     resource_property &lt;-       resource_property_representation.property       resource_property_representation       resource_property_representation.representation -&gt;         { representation =&gt;           machining_tool_body_representation }           representation           representation.items[] -&gt;             { representation_item.name = 'taper angle' }             representation_item =&gt;               measure_representation_item &lt;=                 measure_with_unit =&gt;                   plane_angle_measure_with_unit </pre>
TAPPING_CUTTING_TOOL	machining_tool	10303-238		<pre> machining_tool &lt;=   action_resource   { (action_resource.description = 'tapping tool')     (action_resource.description = 'combined drill and tap') } } </pre>

**Table 9 — Mapping table for cutting tools for milling UoF (continued)**

Application element	AIM element	Source	Rules	Reference path
thread_form_type	descriptive_representation_item.-description	10303-45		<pre> machining_tool &lt;=   action_resource   characterized_resource_definition = action_resource   characterized_resource_definition &lt;-     resource_property.resource     { resource_property.name = 'tool body' }     resource_property &lt;-       resource_property_representation.property       resource_property_representation       resource_property_representation.representation -&gt;       { representation =&gt;         machining_tool_body_representation }         representation         representation.items[i] -&gt;         { representation_item.name = 'thread form type' }         representation_item =&gt;         descriptive_representation_item         descriptive_representation_item.description </pre>

**Table 9 — Mapping table for cutting tools for milling UoF (continued)**

Application element	AIM element	Source	Rules	Reference path
thread_size	length_measure_with_unit	10303-41		<pre> machining_tool &lt;=   action_resource characterized_resource_definition = action_resource characterized_resource_definition &lt;-   resource_property.resource { resource_property.name = 'tool body' } resource_property &lt;-   resource_property_representation.property resource_property_representation resource_property_representation.representation -&gt; { representation =&gt;   machining_tool_body_representation }   representation   representation.items[] -&gt; { representation_item.name = 'thread size' }   representation_item =&gt;   measure_representation_item &lt;=   measure_with_unit =&gt;   length_measure_with_unit </pre>

**Table 9 — Mapping table for cutting tools for milling UoF (continued)**

Application element	AIM element	Source	Rules	Reference path
thread_pitch	length_measure_with_unit	10303-41		<pre> machining_tool &lt;=   action_resource characterized_resource_definition = action_resource characterized_resource_definition &lt;-   resource_property.resource { resource_property.name = 'tool body' }   resource_property &lt;- resource_property_representation.property resource_property_representation resource_property_representation.representation -&gt; { representation =&gt;   machining_tool_body_representation }   representation   representation.items[i] -&gt; { representation_item.name = 'thread pitch' }   representation_item =&gt; measure_representation_item &lt;= measure_with_unit =&gt; length_measure_with_unit </pre>

**Table 9 — Mapping table for cutting tools for milling UoF (continued)**

Application element	AIM element	Source	Rules	Reference path
taper_thread_count	count_measure	10303-41		<pre> maching_tool &lt;=   action_resource characterized_resource_definition = action_resource characterized_resource_definition &lt;-   resource_property.resource { resource_property.name = 'tool body' } resource_property &lt;- resource_property_representation.property resource_property_representation resource_property_representation.representation -&gt; { representation =&gt;   machining_tool_body_representation } representation representation.items[] -&gt; { representation_item.name = 'taper thread count' } representation_item =&gt;   measure_representation_item &lt;=   measure_with_unit measure_with_unit.value_component -&gt;   measure_value measure_value = count_measure count_measure </pre>
THREAD_MILL	machining_tool	10303-238		<pre> machining_tool &lt;=   action_resource { action_resource.description = 'thread mill' } </pre>

**Table 9 — Mapping table for cutting tools for milling UoF (continued)**

Application element	AIM element	Source	Rules	Reference path
thread_form_type	descriptive_representation_item.-description	10303-45		<pre> machining_tool &lt;=   action_resource characterized_resource_definition = action_resource characterized_resource_definition &lt;-   resource_property.resource { resource_property.name = 'tool body' } resource_property &lt;-   resource_property_representation.property resource_property_representation resource_property_representation.representation -&gt; { representation =&gt;   machining_tool_body_representation }   representation   representation.items[i] -&gt; { representation_item.name = 'thread form type' }   representation_item =&gt;   descriptive_representation_item   descriptive_representation_item.description </pre>



**Table 9 — Mapping table for cutting tools for milling UoF (continued)**

Application element	AIM element	Source	Rules	Reference path
thread_size	length_measure_with_unit	10303-41		<pre> machining_tool &lt;=   action_resource characterized_resource_definition = action_resource characterized_resource_definition &lt;-   resource_property.resource { resource_property.name = 'tool body' } resource_property &lt;-   resource_property_representation.property resource_property_representation resource_property_representation.representation -&gt; { representation =&gt;   machining_tool_body_representation }   representation   representation.items[] -&gt; { representation_item.name = 'thread size' }   representation_item =&gt;   measure_representation_item &lt;=   measure_with_unit =&gt;   length_measure_with_unit </pre>

**Table 9 — Mapping table for cutting tools for milling UoF (continued)**

Application element	AIM element	Source	Rules	Reference path
thread_pitch	length_measure_with_unit	10303-41		<pre> machining_tool &lt;=   action_resource characterized_resource_definition = action_resource characterized_resource_definition &lt;-   resource_property.resource { resource_property.name = 'tool body' } resource_property &lt;-   resource_property_representation.property resource_property_representation resource_property_representation.representation -&gt;   { representation =&gt;     machining_tool_body_representation } representation representation.items[i] -&gt;   { representation_item.name = 'thread pitch' } representation_item =&gt;   measure_representation_item &lt;=   measure_with_unit =&gt;   length_measure_with_unit </pre>
TWIST_DRILL	machining_tool	10303-238		<pre> machining_tool &lt;=   action_resource { (action_resource.description = 'twist drill')   (action_resource.description = 'tapered drill') } </pre>
USER_DEFINED_MILLING_TOOL	machining_tool	10303-238		<pre> machining_tool &lt;=   action_resource { action_resource.description = 'user defined milling tool' } </pre>

**Table 9 — Mapping table for cutting tools for milling UoF (continued)**

Application element	AIM element	Source	Rules	Reference path
corner_radius	length_measure_with_unit	10303-41		<pre> machining_tool &lt;= action_resource characterized_resource_definition = action_resource characterized_resource_definition &lt;- resource_property.resource { resource_property.name = 'tool body' } resource_property &lt;- resource_property_representation.property resource_property_representation resource_property_representation.representation -&gt; { representation =&gt; machining_tool_body_representation } representation representation.items[i] -&gt; { representation_item.name = 'corner radius' } representation_item =&gt; measure_representation_item &lt;= measure_with_unit =&gt; length_measure_with_unit </pre>

**Table 9 — Mapping table for cutting tools for milling UoF (continued)**

Application element	AIM element	Source	Rules	Reference path
corner_radius_center_horizontal	length_measure_with_unit	10303-41		<pre> maching_tool &lt;= action_resource characterized_resource_definition = action_resource characterized_resource_definition &lt;- resource_property.resource { resource_property.name = 'tool body' } resource_property &lt;- resource_property_representation.property resource_property_representation resource_property_representation.representation -&gt; { representation =&gt; maching_tool_body_representation } representation representation.items[] -&gt; { representation_item.name = 'corner radius center horizontal' } representation_item =&gt; measure_representation_item &lt;= measure_with_unit =&gt; length_measure_with_unit                     </pre>

**Table 9 — Mapping table for cutting tools for milling UoF (continued)**

Application element	AIM element	Source	Rules	Reference path
corner_radius_center_vertical	length_measure_with_unit	10303-41		<pre> maching_tool &lt;= action_resource characterized_resource_definition = action_resource characterized_resource_definition &lt;- resource_property.resource { resource_property.name = 'tool body' } resource_property &lt;- resource_property_representation.property resource_property_representation resource_property_representation.representation -&gt; { representation =&gt; maching_tool_body_representation } representation representation.items[i] -&gt; { representation_item.name = 'corner radius center vertical' } representation_item =&gt; measure_representation_item &lt;= measure_with_unit =&gt; length_measure_with_unit                     </pre>

**Table 9 — Mapping table for cutting tools for milling UoF (continued)**

Application element	AIM element	Source	Rules	Reference path
description	descriptive_representation_item.-description	10303-45		<pre> machining_tool &lt;=   action_resource characterized_resource_definition = action_resource characterized_resource_definition &lt;-   resource_property.resource { resource_property.name = 'tool body' } resource_property &lt;-   resource_property_representation.property resource_property_representation resource_property_representation.representation -&gt; { representation =&gt;   machining_tool_body_representation }   representation   representation.items[] -&gt; { representation_item.name = 'tool description' }   representation_item =&gt;   descriptive_representation_item   descriptive_representation_item.description </pre>

**Table 9 — Mapping table for cutting tools for milling UoF (continued)**

Application element	AIM element	Source	Rules	Reference path
taper_angle	plane_angle_measure_with_unit	10303-41		<pre> machining_tool &lt;=   action_resource characterized_resource_definition = action_resource characterized_resource_definition &lt;-   resource_property.resource { resource_property.name = 'tool body' } resource_property &lt;-   resource_property_representation.property resource_property_representation resource_property_representation.representation -&gt; { representation =&gt;   machining_tool_body_representation }   representation   representation.items[i] -&gt; { representation_item.name = 'taper angle' }   representation_item =&gt;   measure_representation_item &lt;=   measure_with_unit =&gt;   plane_angle_measure_with_unit </pre>

**Table 9 — Mapping table for cutting tools for milling UoF (continued)**

Application element	AIM element	Source	Rules	Reference path
tip_outer_angle	plane_angle_measure_with_unit	10303-41		<pre> maching_tool &lt;= action_resource characterized_resource_definition = action_resource characterized_resource_definition &lt;- resource_property.resource { resource_property.name = 'tool body' } resource_property &lt;- resource_property_representation.property resource_property_representation resource_property_representation.representation -&gt; { representation =&gt; maching_tool_body_representation } representation representation.items[] -&gt; { representation_item.name = 'tip outer angle' } representation_item =&gt; measure_representation_item &lt;= measure_with_unit =&gt; plane_angle_measure_with_unit                     </pre>



**Table 10 — Mapping table for turning features UoF**

Application element	AIM element	Source	Rules	Reference path
DIAGONAL_KNURL	turned_knurl	10303-522		<pre> turned_knurl &lt;= { feature_definition =&gt;   { instantiated_feature }   feature_definition &lt;=   characterized_object   characterized_object.description = 'diagonal' } </pre>
helix_angle	plane_angle_measure_with_unit	10303-41		<pre> turned_knurl &lt;= feature_definition &lt;= characterized_object characterized_definition = characterized_object characterized_definition &lt;- property_definition.definition { property_definition =&gt;   product_definition_shape } property_definition &lt;- property_definition.definition { property_definition_representation =&gt;   shape_definition_representation } property_definition_representation property_definition_representation.used_representation -&gt; { representation =&gt;   shape_representation =&gt;   shape_representation_with_parameters } representation representation.items[i] -&gt; { representation_item.name = 'helix angle' } representation_item =&gt; measure_representation_item &lt;= measure_with_unit =&gt; plane_angle_measure_with_unit </pre>

**Table 10 — Mapping table for turning features UoF (continued)**

Application element	AIM element	Source	Rules	Reference path
DIAMOND_KNURL	turned_knurl	10303-522		<pre> turned_knurl &lt;= {   feature_definition =&gt;   {     instanced_feature }   feature_definition &lt;=   characterized_object   {     characterized_object.description = 'diamond' } } </pre>
helix_angle	plane_angle_measure_with_unit	10303-41		<pre> turned_knurl &lt;= feature_definition &lt;= characterized_object characterized_definition = characterized_object characterized_definition &lt;- property_definition.definition {   property_definition =&gt;   {     product_definition_shape }   property_definition &lt;-   property_definition.definition   property_definition_representation.definition   {     property_definition_representation =&gt;     shape_definition_representation }   property_definition_representation   property_definition_representation.used_representation -&gt;   {     representation =&gt;     shape_representation =&gt;     shape_representation_with_parameters }   representation   representation.items[i] -&gt;   {     representation_item.name = 'helix angle' }   representation_item =&gt;   {     measure_representation_item &lt;=     measure_with_unit =&gt;     plane_angle_measure_with_unit   } } </pre>

**Table 10 — Mapping table for turning features UoF (continued)**

Application element	AIM element	Source	Rules	Reference path
helix2_angle	plane_angle_measure_with_unit	10303-41		<pre> turned_knurll &lt;= feature_definition &lt;= characterized_object characterized_definition = characterized_object characterized_definition &lt;- property_definition.definition { property_definition =&gt; product_definition_shape } property_definition &lt;- property_definition.definition { property_definition_representation =&gt; shape_definition_representation } property_definition_representation property_definition_representation.used_representation -&gt; { representation =&gt; shape_representation =&gt; shape_representation_with_parameters } representation representation.items[i] -&gt; { representation_item.name = 'helix second angle' } representation_item =&gt; measure_representation_item &lt;= measure_with_unit =&gt; plane_angle_measure_with_unit                     </pre>
GENERAL_REVOLUTION	revolved_profile	10303-522		<pre> revolved_profile &lt;= { feature_definition =&gt; instanced_feature } feature_definition &lt;= characterized_object characterized_object.description = 'open profile' }                     </pre>

**Table 10 — Mapping table for turning features UoF (continued)**

Application element	AIM element	Source	Rules	Reference path
general_revolution to general_profile (as outer_edge_profile)	PATH			<pre>                     revolved_profile &lt;=                     feature_definition &lt;=                     characterized_object                     characterized_definition = characterized_object                     characterized_definition &lt;-                     property_definition.definition                     property_definition =&gt;                     product_definition_shape &lt;-                     shape_aspect.of_shape                     { shape_aspect.description = 'outer edge shape occurrence' }                     shape_aspect &lt;-                     shape_aspect.related_shape_aspect                     shape_aspect.relationship.description = 'profile usage' }                     { shape_aspect.relationship =&gt;                     shape_defining_relationship }                     shape_aspect.relationship                     shape_aspect.relationship.relation = 'outer edge shape' -&gt;                     { shape_aspect.description = 'outer edge shape' }                     shape_aspect =&gt;                     open_path_profile                 </pre>
GROOVE	revolved_profile	10303-522		<pre>                     revolved_profile &lt;=                     { feature_definition =&gt;                     instanced_feature }                     feature_definition &lt;=                     characterized_object                     { characterized_object.description = 'groove' }                 </pre>

**Table 10 — Mapping table for turning features UoF (continued)**

Application element	AIM element	Source	Rules	Reference path
groove to open_profile (as sweep)	PATH			<pre> revolved_profile &lt;= feature_definition &lt;= characterized_object characterized_definition = characterized_object characterized_definition &lt;- property_definition.definition property_definition =&gt; product_definition_shape &lt;- shape_aspect.of_shape { shape_aspect.description = 'sweep occurrence' } shape_aspect &lt;- shape_aspect.related_shape_aspect shape_aspect.relationship.description = 'profile usage' } { shape_aspect.relationship =&gt; shape_defining_relationship } shape_aspect.relationship shape_aspect.relationship.relatng_shape_aspect -&gt; { shape_aspect.description = 'sweep' } shape_aspect =&gt; (open_path_profile) (partial_circular_profile) (rounded_u_profile) (square_u_profile) (tee_profile) (vee_profile) </pre>
KNURL	turned_knur1	10303-522		<pre> turned_knur1 &lt;= { feature_definition =&gt; instanced_feature } feature_definition &lt;= characterized_object </pre>

**Table 10 — Mapping table for turning features UoF (continued)**

Application element	AIM element	Source	Rules	Reference path
knurl to turning_feature (as base_feature)	PATH			<pre> turned_knurl &lt;= feature_definition &lt;= characterized_object characterized_definition = characterized_object characterized_definition &lt;- property_definition.definition property_definition =&gt; product_definition_shape &lt;- shape_aspect.of_shape shape_aspect &lt;- shape_aspect.related_shape_aspect shape_aspect_relationship.description = 'applied shape' } { shape_aspect_relationship =&gt; shape_defining_relationship } shape_aspect_relationship shape_aspect_relationship.relatng_shape_aspect -&gt; shape_aspect =&gt; instanced_feature &lt;= feature_definition =&gt; (out_round) (revolved_profile) (turned_knurl)                     </pre>

**Table 10 — Mapping table for turning features UoF (continued)**

Application element	AIM element	Source	Rules	Reference path
knurl to partial_area_definition (as partial_profile)	PATH			<pre> turned_knurl &lt;= feature_definition &lt;= characterized_object characterized_definition = characterized_object characterized_definition &lt;- property_definition.definition property_definition =&gt; product_definition_shape &lt;- shape_aspect.of_shape shape_aspect &lt;- shape_aspect.related_shape_aspect shape_aspect.relationship.description = 'applied area usage' } { shape_aspect_relationship =&gt; shape_defining_relationship } shape_aspect_relationship shape_aspect_relationship.relatng_shape_aspect -&gt; shape_aspect =&gt; applied_area                     </pre>

**Table 10 — Mapping table for turning features UoF (continued)**

Application element	AIM element	Source	Rules	Reference path
tooth_depth	length_measure_with_unit	10303-41		<pre> tuned_knur1 &lt;= feature_definition &lt;= characterized_object characterized_definition = characterized_object characterized_definition &lt;- property_definition.definition { property_definition =&gt; product_definition_shape } property_definition &lt;- property_definition_representation.definition { property_definition_representation =&gt; shape_definition_representation } property_definition_representation property_definition_representation.used_representation -&gt; { representation =&gt; shape_representation =&gt; shape_representation_with_parameters } representation representation.items[i] -&gt; { representation_item.name = 'tooth depth' } representation_item =&gt; measure_representation_item &lt;= measure_with_unit =&gt; length_measure_with_unit                     </pre>



**Table 10 — Mapping table for turning features UoF (continued)**

Application element	AIM element	Source	Rules	Reference path
diametral_pitch	plane_angle_measure_with_unit	10303-41		<pre> tuned_knur1 &lt;= feature_definition &lt;= characterized_object characterized_definition = characterized_object characterized_definition &lt;- property_definition.definition { property_definition =&gt; product_definition_shape } property_definition &lt;- property_definition_representation.definition { property_definition_representation =&gt; shape_definition_representation } property_definition_representation property_definition_representation.used_representation -&gt; { representation =&gt; shape_representation =&gt; shape_representation_with_parameters } representation representation.items[i] -&gt; { representation_item.name = 'diametral_pitch' } representation_item =&gt; measure_representation_item &lt;= measure_with_unit =&gt; plane_angle_measure_with_unit                     </pre>

**Table 10 — Mapping table for turning features UoF (continued)**

Application element	AIM element	Source	Rules	Reference path
root_fillet	length_measure_with_unit	10303-41		<pre> tuned_knur1 &lt;= feature_definition &lt;= characterized_object characterized_definition = characterized_object characterized_definition &lt;- property_definition.definition { property_definition =&gt; product_definition_shape } property_definition &lt;- property_definition_representation.definition { property_definition_representation =&gt; shape_definition_representation } property_definition_representation property_definition_representation.used_representation -&gt; { representation =&gt; shape_representation =&gt; shape_representation_with_parameters } representation representation.items[i] -&gt; { representation_item.name = 'root fillet' } representation_item =&gt; measure_representation_item &lt;= measure_with_unit =&gt; length_measure_with_unit                     </pre>

**Table 10 — Mapping table for turning features UoF (continued)**

Application element	AIM element	Source	Rules	Reference path
number_of_teeth	count_measure	10303-41		<pre> turned_knurrl &lt;= feature_definition &lt;= characterized_object characterized_definition = characterized_object characterized_definition &lt;- property_definition.definition { property_definition =&gt; product_definition_shape } property_definition &lt;- property_definition_representation.definition { property_definition_representation =&gt; shape_definition_representation } property_definition_representation property_definition_representation.used_representation -&gt; { representation =&gt; shape_representation =&gt; shape_representation_with_parameters } representation representation.items[i] -&gt; { representation_item.name = 'number of teeth' } representation_item =&gt; measure_representation_item &lt;= measure_with_unit measure_with_unit_value_component -&gt; measure_value count_measure count_measure                     </pre>

**Table 10 — Mapping table for turning features UoF (continued)**

Application element	AIM element	Source	Rules	Reference path
major_diameter	length_measure_with_unit	10303-41		<pre> tuned_knur1 &lt;= feature_definition &lt;= characterized_object characterized_definition = characterized_object characterized_definition &lt;- property_definition.definition { property_definition =&gt; product_definition_shape } property_definition &lt;- property_definition_representation.definition { property_definition_representation =&gt; shape_definition_representation } property_definition_representation property_definition_representation.used_representation -&gt; { representation =&gt; shape_representation =&gt; shape_representation_with_parameters } representation representation.items[i] -&gt; { representation_item.name = 'major diameter' } representation_item =&gt; measure_representation_item &lt;= measure_with_unit =&gt; length_measure_with_unit                     </pre>

**Table 10 — Mapping table for turning features UoF (continued)**

Application element	AIM element	Source	Rules	Reference path
nominal_diameter	length_measure_with_unit	10303-41		<pre> tuned_knurrl &lt;= feature_definition &lt;= characterized_object characterized_definition = characterized_object characterized_definition &lt;- property_definition.definition { property_definition =&gt; product_definition_shape } property_definition &lt;- property_definition_representation.definition { property_definition_representation =&gt; shape_definition_representation } property_definition_representation property_definition_representation.used_representation -&gt; { representation =&gt; shape_representation =&gt; shape_representation_with_parameters } representation representation.items[i] -&gt; { representation_item.name = 'nominal diameter' } representation_item =&gt; measure_representation_item &lt;= measure_with_unit =&gt; length_measure_with_unit                     </pre>
OUTER_DIAMETER	outer_round	10303-522		<pre> outer_round &lt;= { feature_definition =&gt; instanced_feature } feature_definition &lt;= characterized_object { characterized_object.description = 'outer diameter' }                     </pre>

**Table 10 — Mapping table for turning features UoF (continued)**

Application element	AIM element	Source	Rules	Reference path
diameter_at_placement	length_measure_with_unit	10303-41		<pre> outer_round &lt;= feature_definition &lt;= characterized_object characterized_definition = characterized_object characterized_definition &lt;- property_definition.definition { property_definition =&gt; product_definition_shape } property_definition &lt;- property_definition_representation.definition { property_definition_representation =&gt; shape_definition_representation } property_definition_representation property_definition_representation.used_representation -&gt; { representation =&gt; shape_representation =&gt; shape_representation_with_parameters } representation representation.items[i] -&gt; { representation_item.name = 'diameter' } representation_item =&gt; measure_representation_item &lt;= measure_with_unit =&gt; length_measure_with_unit                     </pre>

**Table 10 — Mapping table for turning features UoF (continued)**

Application element	AIM element	Source	Rules	Reference path
feature_length	length_measure_with_unit	10303-41		<pre> outer_round &lt;= feature_definition &lt;= characterized_object characterized_definition = characterized_object characterized_definition &lt;- property_definition.definition { property_definition =&gt; product_definition_shape } property_definition &lt;- property_definition_representation.definition { property_definition_representation =&gt; shape_definition_representation } property_definition_representation property_definition_representation.used_representation -&gt; { representation =&gt; shape_representation =&gt; shape_representation_with_parameters } representation representation.items[i] -&gt; { representation_item.name = 'length' } representation_item =&gt; measure_representation_item &lt;= measure_with_unit =&gt; length_measure_with_unit                     </pre>

**Table 10 — Mapping table for turning features UoF (continued)**

Application element	AIM element	Source	Rules	Reference path
outer_diameter to taper_select (as reduced_size) #1: as angle_taper #2: as diameter_taper	PATH			<pre> outer_round &lt;= feature_definition &lt;= characterized_object characterized_definition = characterized_object characterized_definition &lt;- property_definition.definition property_definition =&gt; product_definition_shape &lt;- shape_aspect.of_shape { shape_aspect.description = 'reduced size occurrence' } shape_aspect &lt;- shape_aspect.related_shape_aspect { shape_aspect.relationship =&gt; feature_component_relationship } { shape_aspect.relationship.name = 'reduced size' } { shape_aspect.relationship.description = 'taper usage' } shape_aspect.relationship shape_aspect.relationship.relation_shape_aspect -&gt; { #1: (shape_aspect.description = 'angle taper') #2: (shape_aspect.description = 'diameter taper') } shape_aspect =&gt; taper                     </pre>
OUTER_DIAMETER_TO_SHOULDER	outer_round	10303-522		<pre> outer_round &lt;= { feature_definition =&gt; instanced_feature } feature_definition &lt;= characterized_object { characterized_object.description = 'outer diameter to shoulder' }                     </pre>



**Table 10 — Mapping table for turning features UoF (continued)**

Application element	AIM element	Source	Rules	Reference path
diameter_at_placement	length_measure_with_unit	10303-41		<pre> outer_round &lt;= feature_definition &lt;= characterized_object characterized_definition = characterized_object characterized_definition &lt;- property_definition.definition { property_definition =&gt; product_definition_shape } property_definition &lt;- property_definition_representation.definition { property_definition_representation =&gt; shape_definition_representation } property_definition_representation property_definition_representation.used_representation -&gt; { representation =&gt; shape_representation =&gt; shape_representation_with_parameters } representation representation.items[i] -&gt; { representation_item.name = 'diameter' } representation_item =&gt; measure_representation_item &lt;= measure_with_unit =&gt; length_measure_with_unit                     </pre>

**Table 10 — Mapping table for turning features UoF (continued)**

Application element	AIM element	Source	Rules	Reference path
outer_diameter_to_shoulder_to_vee_profile (as v_shape_boundary)	PATH			<pre> outer_round &lt;= feature_definition &lt;= characterized_object characterized_definition = characterized_object characterized_definition &lt;- property_definition.definition property_definition =&gt; product_definition_shape &lt;- shape_aspect.of_shape { shape_aspect.description = 'v-shape boundary occurrence' } shape_aspect &lt;- shape_aspect.related_shape_aspect shape_aspect.relationship.description = 'profile usage' } { shape_aspect.relationship =&gt; shape_defining_relationship } shape_aspect.relationship shape_aspect.relationship.relatng_shape_aspect -&gt; { shape_aspect.description = 'v-shape' } shape_aspect =&gt; vee_profile                     </pre>
OUTER_ROUND	outer_round	10303-522		<pre> outer_round &lt;= { feature_definition =&gt; instanced_feature } feature_definition &lt;= characterized_object                     </pre>
REVOLVED_FEATURE	revolved_profile	10303-522		<pre> revolved_profile &lt;= { feature_definition =&gt; instanced_feature } feature_definition &lt;= characterized_object                     </pre>

**Table 10 — Mapping table for turning features UoF (continued)**

Application element	AIM element	Source	Rules	Reference path
material_side	direction	10303-42		<pre> revolved_profile &lt;= feature_definition &lt;= characterized_object characterized_definition = characterized_object characterized_definition &lt;- property_definition.definition { property_definition =&gt; product_definition_shape } property_definition &lt;- property_definition_representation.definition property_definition_representation property_definition_representation.used_representation -&gt; { representation.name = 'removal direction' } representation { representation =&gt; shape_representation =&gt; direction_shape_representation } representation.items[i] -&gt; representation_item =&gt; geometric_representation_item =&gt; direction                     </pre>

**Table 10 — Mapping table for turning features UoF (continued)**

Application element	AIM element	Source	Rules	Reference path
radius	length_measure_with_unit	10303-41		<pre> revolved_profile &lt;= feature_definition &lt;= characterized_object characterized_definition = characterized_object characterized_definition &lt;- property_definition.definition { property_definition =&gt; product_definition_shape } property_definition &lt;- property_definition_representation.definition { property_definition_representation =&gt; shape_definition_representation } property_definition_representation property_definition_representation.used_representation -&gt; { representation =&gt; shape_representation =&gt; shape_representation_with_parameters } representation representation.items[i] -&gt; { representation_item.name = 'radius' } representation_item =&gt; measure_representation_item &lt;= measure_with_unit =&gt; length_measure_with_unit                     </pre>
REVOLVED_FLAT	revolved_profile	10303-522		<pre> revolved_profile &lt;= { feature_definition =&gt; instanced_feature } feature_definition &lt;= characterized_object { characterized_object.description = 'flat' }                     </pre>

**Table 10 — Mapping table for turning features UoF (continued)**

Application element	AIM element	Source	Rules	Reference path
revolved_flat to linear_profile (as flat_edge_shape)	PATH			<pre>                     revolved_profile &lt;=                     feature_definition &lt;=                     characterized_object                     characterized_definition = characterized_object                     characterized_definition &lt;-                     property_definition.definition                     product_definition_shape &lt;-                     shape_aspect.of_shape                     { shape_aspect.description = 'flat edge shape occurrence' }                     shape_aspect &lt;-                     shape_aspect.related_shape_aspect                     shape_aspect.relationship.description = 'profile usage' }                     { shape_aspect.relationship =&gt;                     shape_defining_relationship }                     shape_aspect.relationship                     shape_aspect.relationship.relatng_shape_aspect -&gt;                     { shape_aspect.description = 'flat edge shape' } }                     shape_aspect =&gt;                     linear_profile                 </pre>
REVOLVED_ROUND	revolved_profile	10303-522		<pre>                     revolved_profile &lt;=                     { feature_definition =&gt;                     instanced_feature }                     feature_definition &lt;=                     characterized_object                     { characterized_object.description = 'round' } }                 </pre>

**Table 10 — Mapping table for turning features UoF (continued)**

Application element	AIM element	Source	Rules	Reference path
revolved_round to partial_circular_profile (as rounded_edge_shape)	PATH			<pre>                     revolved_profile &lt;=                     feature_definition &lt;=                     characterized_object                     characterized_definition = characterized_object                     characterized_definition &lt;-                     property_definition.definition                     property_definition =&gt;                     product_definition_shape &lt;-                     shape_aspect.of_shape                     shape_aspect.description = 'rounded edge shape occurrence' }                     shape_aspect &lt;-                     shape_aspect.related_shape_aspect                     shape_aspect.relationship.description = 'profile usage' }                     { shape_aspect.relationship =&gt;                     shape_defining_relationship }                     shape_aspect.relationship                     shape_aspect.relationship.relatng_shape_aspect -&gt;                     { shape_aspect.description = 'rounded edge shape' }                     shape_aspect =&gt;                     partial_circular_profile                 </pre>
STRAIGHT_KNURL	turned_knurl	10303-522		<pre>                     turned_knurl &lt;=                     { feature_definition =&gt;                     instanced_feature }                     feature_definition &lt;=                     characterized_object                     { characterized_object.description = 'straight' }                 </pre>
TOOL_KNURL	turned_knurl	10303-522		<pre>                     turned_knurl &lt;=                     { feature_definition =&gt;                     instanced_feature }                     feature_definition &lt;=                     characterized_object                     { characterized_object.description = 'tool' }                 </pre>

**Table 10 — Mapping table for turning features UoF (continued)**

Application element	AIM element	Source	Rules	Reference path
TURNING_FEATURE	(outer_round) (revolved_profile) (turned_knur1)	10303-522 10303-522 10303-522		(outer_round <= (revolved_profile <= (turned_knur1 <= { feature_definition => instanced_feature } feature_definition <= characterized_object

**Table 11 — Mapping table for process data for turning UoF**

Application element	AIM element	Source	Rules	Reference path
BIDIRECTIONAL_TURNING	turning_type_strategy	10303-238		turning_type_strategy <= machining_strategy <= action_method { action_method.description = 'bidirectional' }
feed_direction	direction	10303-42		turning_type_strategy <= machining_strategy <= action_method characterized_action_definition = action_method characterized_action_definition <- action_property.definition { action_property.name = 'feed direction' } action_property <- action_property_representation.property action_property_representation action_property_representation.representation -> representation representation.items[i] -> representation_item => geometric_representation_item => direction



Table 11 — Mapping table for process data for turning UoF (continued)

Application element	AIM element	Source	Rules	Reference path
stepover_direction	direction	10303-42		<pre> turning_type_strategy &lt;= machining_strategy &lt;= action_method characterized_action_definition = action_method characterized_action_definition &lt;- action_property.definition { action_property.name = 'stepover direction' } action_property &lt;- action_property_representation.property action_property_representation action_property_representation.representation -&gt; representation representation.items[i] -&gt; representation_item =&gt; geometric_representation_item =&gt; direction </pre>
stepover_feed	machining_feed_speed_- representation	10303-238		<pre> turning_type_strategy &lt;= machining_strategy &lt;= action_method characterized_action_definition = action_method characterized_action_definition &lt;- action_property.definition { action_property.name = 'stepover feedrate' } action_property &lt;- action_property_representation.property action_property_representation action_property_representation.representation -&gt; { (representation.name = 'feed speed') (representation.name = 'feed per revolution') } representation =&gt; machining_feed_speed_representation </pre>
CONST_CUTTING_SPEED	machining_spindle_speed_- representation	10303-238		<pre> machining_spindle_speed_representation &lt;= representation { representation.name = 'cutting speed' } </pre>

**Table 11 — Mapping table for process data for turning UoF (continued)**

Application element	AIM element	Source	Rules	Reference path
speed	measure_with_unit	10303-41		<pre> machining_spindle_speed_representation &lt;=   representation   representation.items[i] -&gt;   { representation_item.name = 'surface speed' }   representation_item =&gt;   measure_representation_item &lt;=   measure_with_unit   { measure_with_unit.value_component -&gt;   measure_value   measure_value = numeric_measure   numeric_measure } </pre>
max_speed	measure_with_unit	10303-41		<pre> machining_spindle_speed_representation &lt;=   representation   { representation_item.name = 'maximum rotational speed' }   representation_item =&gt;   measure_representation_item &lt;=   measure_with_unit   { measure_with_unit.value_component -&gt;   measure_value   measure_value = numeric_measure   numeric_measure } </pre>
CONST_SPINDLE_SPEED	machining_spindle_speed_representation	10303-238		<pre> machining_spindle_speed_representation &lt;=   representation   {representation.name = 'spindle speed' } </pre>

**Table 11 — Mapping table for process data for turning UoF (continued)**

Application element	AIM element	Source	Rules	Reference path
rot_speed	measure_with_unit	10303-41		<pre> machining_spindle_speed_representation &lt;=   representation   representation.items[i] -&gt;   { representation_item.name = 'rotational speed' }   representation_item =&gt;   measure_representation_item &lt;=   measure_with_unit   { measure_with_unit.value_component -&gt;   measure_value   measure_value = numeric_measure   numeric_measure } </pre>
CONTOUR_TURNING	turning_type_strategy	10303-238		<pre> turning_type_strategy &lt;=   machining_strategy &lt;=   action_method   { action_method.description = 'contour' } </pre>
feed_direction	direction	10303-42		<pre> turning_type_strategy &lt;=   machining_strategy &lt;=   action_method   characterized_action_definition = action_method   characterized_action_definition &lt;-   action_property.definition   { action_property.name = 'feed direction' }   action_property &lt;-   action_property_representation.property   action_property_representation   action_property_representation.representation -&gt;   representation   representation.items[i] -&gt;   representation_item =&gt;   geometric_representation_item =&gt;   direction </pre>

**Table 11 — Mapping table for process data for turning UoF (continued)**

Application element	AIM element	Source	Rules	Reference path
back_path_direction	direction	10303-42		<pre> turning_type_strategy &lt;= machining_strategy &lt;= action_method characterized_action_definition = action_method characterized_action_definition &lt;- action_property.definition { action_property.name = 'back path direction' } action_property &lt;- action_property_representation.property action_property_representation action_property_representation.representation -&gt; representation representation.items[i] -&gt; representation_item =&gt; geometric_representation_item =&gt; direction                     </pre>
lift_direction	direction	10303-42		<pre> turning_type_strategy &lt;= machining_strategy &lt;= action_method characterized_action_definition = action_method characterized_action_definition &lt;- action_property.definition { action_property.name = 'lift direction' } action_property &lt;- action_property_representation.property action_property_representation action_property_representation.representation -&gt; representation representation.items[i] -&gt; representation_item =&gt; geometric_representation_item =&gt; direction                     </pre>

**Table 11 — Mapping table for process data for turning UoF (continued)**

Application element	AIM element	Source	Rules	Reference path
stepover_direction	direction	10303-42		<pre> turning_type_strategy &lt;= machining_strategy &lt;= action_method characterized_action_definition = action_method characterized_action_definition &lt;- action_property.definition { action_property.name = 'stepover direction' } action_property &lt;- action_property_representation.property action_property_representation action_property_representation.representation -&gt; representation representation.items[i] -&gt; representation_item =&gt; geometric_representation_item =&gt; direction                     </pre>
lift_height	length_measure_with_unit	10303-41		<pre> turning_type_strategy &lt;= machining_strategy &lt;= action_method characterized_action_definition = action_method characterized_action_definition &lt;- action_property.definition { action_property.name = 'lift height' } action_property &lt;- action_property_representation.property action_property_representation action_property_representation.representation -&gt; representation representation.items[i] -&gt; representation_item =&gt; measure_representation_item &lt;= measure_with_unit =&gt; length_measure_with_unit                     </pre>

**Table 11 — Mapping table for process data for turning UoF (continued)**

Application element	AIM element	Source	Rules	Reference path
lift_feed	machining_feed_speed_- representation	10303-238		<pre> turning_type_strategy &lt;= machining_strategy &lt;= action_method characterized_action_definition = action_method characterized_action_definition &lt;- action_property.definition { action_property.name = 'lift feedrate' } action_property &lt;- action_property_representation.property action_property_representation action_property_representation.representation -&gt; { (representation.name = 'feed speed') (representation.name = 'feed per revolution') } representation =&gt; machining_feed_speed_representation                     </pre>
stepover_feed	machining_feed_speed_- representation	10303-238		<pre> turning_type_strategy &lt;= machining_strategy &lt;= action_method characterized_action_definition = action_method characterized_action_definition &lt;- action_property.definition { action_property.name = 'stepover feedrate' } action_property &lt;- action_property_representation.property action_property_representation action_property_representation.representation -&gt; { (representation.name = 'feed speed') (representation.name = 'feed per revolution') } representation =&gt; machining_feed_speed_representation                     </pre>

**Table 11 — Mapping table for process data for turning UoF (continued)**

Application element	AIM element	Source	Rules	Reference path
variable_stepover_feed	ratio_measure_with_unit	10303-41		<pre> turning_type_strategy &lt;= machining_strategy &lt;= action_method characterized_action_definition = action_method characterized_action_definition &lt;- action_property.definition { action_property.name = 'variable stepover feedrate' } action_property &lt;- action_property_representation.property action_property_representation action_property_representation.representation -&gt; { representation =&gt; machining_feed_speed_representation } representation { representation.name = 'relative speed' } representation.items[i] -&gt; { representation_item.name = 'relative speed' } representation_item =&gt; measure_representation_item &lt;= measure_with_unit =&gt; ratio_measure_with_unit </pre>
CONTOURING	contouring_turning_operation	10303-238		<pre> contouring_turning_operation &lt;= turning_type_operation &lt;= machining_operation &lt;= action_method </pre>

**Table 11 — Mapping table for process data for turning UoF (continued)**

Application element	AIM element	Source	Rules	Reference path
allowance	length_measure_with_unit	10303-41		contouring_turning_operation <= turning_type_operation <= machining_operation <= action_method characterized_action_definition = action_method characterized_action_definition <- action_property.definition { action_property.name = 'allowance' } action_property_representation.property action_property_representation action_property_representation.representation -> representation representation.items[] -> representation_item => measure_representation_item <= measure_with_unit => length_measure_with_unit
CONTOURING_FINISH	contouring_turning_operation	10303-238		contouring_turning_operation <= turning_type_operation <= machining_operation <= action_method { action_method.description = 'finishing' }
CONTOURING_ROUGH	contouring_turning_operation	10303-238		contouring_turning_operation <= turning_type_operation <= machining_operation <= action_method { action_method.description = 'roughing' }
CUTTING_IN	grooving_turning_operation	10303-238		grooving_turning_operation <= turning_type_operation <= machining_operation <= action_method { action_method.description = 'cutting in' }



**Table 11 — Mapping table for process data for turning UoF (continued)**

Application element	AIM element	Source	Rules	Reference path
EXPLICIT_TURNING_STRATEGY	turning_type_strategy	10303-238		turning_type_strategy <= machining_strategy <= action_method { action_method.description = 'explicit' }
FACING	facing_turning_operation	10303-238		facing_turning_operation <= turning_type_operation <= machining_operation <= action_method
allowance	length_measure_with_unit	10303-41		facing_turning_operation <= turning_type_operation <= machining_operation <= action_method characterized_action_definition = action_method characterized_action_definition <- action_property_definition { action_property.name = 'allowance' } action_property <- action_property_representation.property action_property_representation action_property_representation.representation -> representation representation.items[i] -> representation_item => measure_representation_item <= measure_with_unit => length_measure_with_unit
FACING_FINISH	facing_turning_operation	10303-238		facing_turning_operation <= turning_type_operation <= machining_operation <= action_method { action_method.description = 'finishing' }

**Table 11 — Mapping table for process data for turning UoF (continued)**

Application element	AIM element	Source	Rules	Reference path
FACING_ROUGH	facing_turning_operation	10303-238		facing_turning_operation <= turning_type_operation <= machining_operation <= action_method { action_method.description = 'roughing' }
GROOVING	grooving_turning_operation	10303-238		grooving_turning_operation <= turning_type_operation <= machining_operation <= action_method
dwell	machining_dwell_time_ - representation	10303-238		grooving_turning_operation <= turning_type_operation <= machining_operation <= action_method characterized_action_definition = action_method characterized_action_definition <- action_property_definition { action_property.name = 'dwell' } action_property <- action_property_representation.property action_property_representation action_property_representation.representation -> { (representation.name = 'dwell time') (representation.name = 'dwell revolution') } representation => machining_dwell_time_representation

**Table 11 — Mapping table for process data for turning UoF (continued)**

Application element	AIM element	Source	Rules	Reference path
allowance	length_measure_with_unit	10303-41		<pre> grooving_turning_operation &lt;= turning_type_operation &lt;= machining_operation &lt;= action_method characterized_action_definition = action_method characterized_action_definition &lt;- action_property.definition { action_property.name = 'allowance' } action_property &lt;- action_property_representation.property action_property_representation action_property_representation.representation -&gt; representation representation.items[i] -&gt; representation_item =&gt; measure_representation_item &lt;= measure_with_unit =&gt; length_measure_with_unit </pre>
GROOVING_FINISH	grooving_turning_operation	10303-238		<pre> grooving_turning_operation &lt;= turning_type_operation &lt;= machining_operation &lt;= action_method { action_method.description = 'finishing' } </pre>
GROOVING_ROUGH	grooving_turning_operation	10303-238		<pre> grooving_turning_operation &lt;= turning_type_operation &lt;= machining_operation &lt;= action_method { action_method.description = 'roughing' } </pre>
GROOVING_STRATEGY	turning_type_strategy	10303-238		<pre> turning_type_strategy &lt;= machining_strategy &lt;= action_method { ( action_method.description = 'grooving' ) ( action_method.description = 'multistep grooving' ) } </pre>

**Table 11 — Mapping table for process data for turning UoF (continued)**

Application element	AIM element	Source	Rules	Reference path
grooving_direction	direction	10303-42		<pre> turning_type_strategy &lt;= machining_strategy &lt;= action_method characterized_action_definition = action_method characterized_action_definition &lt;- action_property.definition { action_property.name = 'grooving direction' } action_property &lt;- action_property_representation.property action_property_representation action_property_representation.representation -&gt; representation representation.items[i] -&gt; representation_item =&gt; geometric_representation_item =&gt; direction                     </pre>
travel_distance	length_measure_with_unit	10303-41		<pre> turning_type_strategy &lt;= machining_strategy &lt;= action_method characterized_action_definition = action_method characterized_action_definition &lt;- action_property.definition { action_property.name = 'travel distance' } action_property &lt;- action_property_representation.property action_property_representation action_property_representation.representation -&gt; representation representation.items[i] -&gt; representation_item =&gt; measure_representation_item &lt;= measure_with_unit =&gt; length_measure_with_unit                     </pre>

Table 11 — Mapping table for process data for turning UoF (continued)

Application element	AIM element	Source	Rules	Reference path
KNURLING	knurling_turning_operation	10303-238		knurling_turning_operation <= turning_type_operation <= machining_operation <= action_method
MULTISTEP_GROOVING_STRATEGY	turning_type_strategy	10303-238		turning_type_strategy <= machining_strategy <= action_method { action_method.description = 'multistep grooving' }
retract_distance	length_measure_with_unit	10303-41		turning_type_strategy <= machining_strategy <= action_method characterized_action_definition = action_method characterized_action_definition <- action_property.definition { action_property.name = 'retract distance' } action_property <- action_property_representation.property action_property_representation action_property_representation.representation -> representation representation.items[j] -> representation_item => measure_representation_item <= measure_with_unit => length_measure_with_unit
THREAD_STRATEGY	turning_type_strategy	10303-238		turning_type_strategy <= machining_strategy <= action_method { action_method.description = 'thread' }

**Table 11 — Mapping table for process data for turning UoF (continued)**

Application element	AIM element	Source	Rules	Reference path
cut_in_amount_function	descriptive_representation_item.-description	10303-45		<pre> turning_type_strategy &lt;= machining_strategy &lt;=   action_method characterized_action_definition = action_method characterized_action_definition &lt;-   action_property.definition   { action_property.name = 'cut in amount' }   action_property &lt;-   action_property_representation.property   action_property_representation   action_property_representation.representation -&gt;   representation   representation.items[i] -&gt;   representation_item =&gt;   descriptive_representation_item   descriptive_representation_item.description   { (descriptive_representation_item.description = 'constant depth' ) (descriptive_representation_item.description = 'variable depth' ) (descriptive_representation_item.description = \ 'constant removal amount' ) } </pre>

**Table 11 — Mapping table for process data for turning UoF (continued)**

Application element	AIM element	Source	Rules	Reference path
threading_direction	descriptive_representation_item.description	10303-45		<pre> turning_type_strategy &lt;= machining_strategy &lt;=   action_method characterized_action_definition = action_method characterized_action_definition &lt;-   action_property.definition { action_property.name = 'threading direction' }   action_property &lt;-   action_property_representation.property   action_property_representation   action_property_representation.representation -&gt;   representation   representation.items[i] -&gt;   representation_item =&gt;   descriptive_representation_item   descriptive_representation_item.description { (descriptive_representation_item.description = 'left' ) (descriptive_representation_item.description = 'right' ) (descriptive_representation_item.description = 'center' ) (descriptive_representation_item.description = 'left zigzag' ) (descriptive_representation_item.description = 'right zigzag' ) } </pre>

**Table 11 — Mapping table for process data for turning UoF (continued)**

Application element	AIM element	Source	Rules	Reference path
path_return_angle	plane_angle_measure_with_unit	10303-41		<pre> turning_type_strategy &lt;= machining_strategy &lt;= action_method characterized_action_definition = action_method characterized_action_definition &lt;- action_property.definition { action_property.name = 'path return angle' } action_property &lt;- action_property_representation.property action_property_representation action_property_representation.representation -&gt; representation representation.items[i] -&gt; representation_item =&gt; measure_representation_item &lt;= measure_with_unit =&gt; plane_angle_measure_with_unit                     </pre>
lift_height	length_measure_with_unit	10303-41		<pre> turning_type_strategy &lt;= machining_strategy &lt;= action_method characterized_action_definition = action_method characterized_action_definition &lt;- action_property.definition { action_property.name = 'lift height' } action_property &lt;- action_property_representation.property action_property_representation action_property_representation.representation -&gt; representation representation.items[i] -&gt; representation_item =&gt; measure_representation_item &lt;= measure_with_unit =&gt; length_measure_with_unit                     </pre>



**Table 11 — Mapping table for process data for turning UoF (continued)**

Application element	AIM element	Source	Rules	Reference path
THREADING	threading_turning_operation	10303-238		threading_turning_operation <= turning_type_operation <= machining_operation <= action_method
allowance	length_measure_with_unit	10303-41		threading_turning_operation <= turning_type_operation <= machining_operation <= action_method characterized_action_definition = action_method characterized_action_definition <- action_property.definition { action_property.name = 'allowance' } action_property <- action_property_representation.property action_property_representation action_property_representation.representation -> representation representation.items[i] -> representation_item => measure_representation_item <= measure_with_unit => length_measure_with_unit
THREADING_FINISH	threading_turning_operation	10303-238		threading_turning_operation <= turning_type_operation <= machining_operation <= action_method { action_method.description = 'finishing' }
THREADING_ROUGH	threading_turning_operation	10303-238		threading_turning_operation <= turning_type_operation <= machining_operation <= action_method { action_method.description = 'roughing' }

**Table 11 — Mapping table for process data for turning UoF (continued)**

Application element	AIM element	Source	Rules	Reference path
TURNING_MACHINE_FUNCTIONS	machining_functions	10303-238		<pre> machining_functions &lt;=   action_method   { action_method.description = 'turning' } </pre>
coolant #1: if value is true #2: if value is false	descriptive_representation_item.-description	10303-45		<pre> machining_functions &lt;=   action_method   characterized_action_definition = action_method   characterized_action_definition &lt;-     action_property.definition     { action_property.name = 'coolant' }     action_property &lt;-       action_property_representation.property       action_property_representation       action_property_representation.representation -&gt;         representation         representation.items[i] -&gt;           representation_item =&gt;             descriptive_representation_item             descriptive_representation_item.description             { #1: (descriptive_representation_item.description = 'coolant on' )               #2: (descriptive_representation_item.description = 'coolant off' ) } </pre>

Table 11 — Mapping table for process data for turning UoF (continued)

Application element	AIM element	Source	Rules	Reference path
coolant_type	descriptive_representation_item.- description	10303-45		<pre> maching_functions &lt;=   action_method characterized_action_definition = action_method characterized_action_definition &lt;-   action_property.definition { action_property.name = 'coolant type' }   action_property &lt;- action_property_representation.property action_property_representation action_property_representation.representation -&gt;   representation representation.items[i] -&gt;   representation_item =&gt;   descriptive_representation_item descriptive_representation_item.description { (descriptive_representation_item.description = 'flood' ) (descriptive_representation_item.description = 'mist' ) (descriptive_representation_item.description = 'through tool' ) } </pre>
coolant_pressure	measure_with_unit	10303-41		<pre> maching_functions &lt;=   action_method characterized_action_definition = action_method characterized_action_definition &lt;-   action_property.definition { action_property.name = 'coolant pressure' }   action_property &lt;- action_property_representation.property action_property_representation action_property_representation.representation -&gt;   representation representation.items[i] -&gt;   representation_item =&gt;   measure_representation_item &lt;=   measure_with_unit </pre>

**Table 11 — Mapping table for process data for turning UoF (continued)**

Application element	AIM element	Source	Rules	Reference path
axis_clamping	descriptive_representation_item.-description	10303-45		<pre> maching_functions &lt;=   action_method characterized_action_definition = action_method characterized_action_definition &lt;-   action_property_definition { action_property.name = 'axis clamping' }   action_property &lt;-     action_property_representation.property   action_property_representation   action_property_representation &lt;-&gt;     representation   representation.items[i] -&gt;     representation_item =&gt;       compound_representation_item   compound_representation_item.item_element -&gt;     compound_item_definition   compound_item_definition = list_representation_item   list_representation_item[i] -&gt;     representation_item =&gt;       descriptive_representation_item   descriptive_representation_item.description </pre>

**Table 11 — Mapping table for process data for turning UoF (continued)**

Application element	AIM element	Source	Rules	Reference path
<p>chip_removal</p> <p>#1: if value is true</p> <p>#2: if value is false (mapping may also be omitted if value is false)</p>	<p>descriptive_representation_item.-description</p>	<p>10303-45</p>		<pre> machining_functions &lt;=   action_method characterized_action_definition = action_method characterized_action_definition &lt;-   action_property_definition { action_property.name = 'chip removal' }   action_property &lt;-   action_property_representation.property   action_property_representation   action_property_representation.representation -&gt;   representation   representation.items[i] -&gt;   representation_item =&gt;   descriptive_representation_item   descriptive_representation_item.description {#1: (descriptive_representation_item.description = \ 'chip removal on' ) #2: (descriptive_representation_item.description = \ 'chip removal off' ) } </pre>
<p>oriented_spindle_stop</p>	<p>direction</p>	<p>10303-42</p>		<pre> machining_functions &lt;=   action_method characterized_action_definition = action_method characterized_action_definition &lt;-   action_property_definition { action_property.name = 'oriented spindle stop' }   action_property &lt;-   action_property_representation.property   action_property_representation   action_property_representation.representation -&gt;   representation   representation.items[i] -&gt;   representation_item =&gt;   geometric_representation_item =&gt;   direction </pre>

**Table 11 — Mapping table for process data for turning UoF (continued)**

Application element	AIM element	Source	Rules	Reference path
turning_machine_functions to process_model (as its_process_model)  See NOTE 21	PATH			<pre>                     machining_functions &lt;=                     action_method &lt;-                     action_method_relationship.relatng_method                     action_method_relationship                     { action_method_relationship =&gt;                     serial_action_method =&gt;                     sequential_method =&gt;                     machining_process_model.relationship }                     action_method_relationship.related_method -&gt;                     action_method =&gt;                     machining_process_model                     </pre>
turning_machine_functions to property_parameter (as other_functions)	PATH			<pre>                     machining_functions &lt;=                     action_method                     characterized_action_definition = action_method                     characterized_action_definition &lt;-                     action_property.definition                     { action_property.name = 'other functions' }                     action_property &lt;-                     action_property_representation.property                     action_property_representation                     action_property_representation.representation -&gt;                     representation                     representation.items[i] -&gt;                     representation_item =&gt;                     compound_representation_item                     compound_representation_item_element -&gt;                     compound_item_definition                     compound_item_definition = set representation_item                     set_representation_item[i] -&gt;                     representation_item                     </pre>

**Table 11 — Mapping table for process data for turning UoF (continued)**

Application element	AIM element	Source	Rules	Reference path
<p>tail_stock</p> <p>#1: if value is true</p> <p>#2: if value is false (mapping may also be omitted if value is false)</p>	<p>descriptive_representation_item.-description</p>	<p>10303-45</p>		<pre> maching_functions &lt;=   action_method characterized_action_definition = action_method characterized_action_definition &lt;-   action_property_definition { action_property.name = 'tail stock' }   action_property &lt;-     action_property_representation.property   action_property_representation   action_property_representation.representation -&gt;     representation   representation.items[i] -&gt;     representation_item =&gt;       descriptive_representation_item   descriptive_representation_item.description { #1: (descriptive_representation_item.description = \ 'tail stock used' ) #2: (descriptive_representation_item.description = \ 'tail stock not used' ) }</pre>

**Table 11 — Mapping table for process data for turning UoF (continued)**

Application element	AIM element	Source	Rules	Reference path
<p>steady_rest</p> <p>#1: if value is true</p> <p>#2: if value is false (mapping may also be omitted if value is false)</p>	<p>descriptive_representation_item.-description</p>	<p>10303-45</p>		<pre> maching_functions &lt;=   action_method characterized_action_definition = action_method characterized_action_definition &lt;-   action_property_definition { action_property.name = 'steady rest' }   action_property &lt;-     action_property_representation.property   action_property_representation   action_property_representation   action_property_representation.representation -&gt;     representation   representation.items[i] -&gt;     representation_item =&gt;       descriptive_representation_item   descriptive_representation_item.description { #1: (descriptive_representation_item.description = \ 'steady rest used' ) #2: (descriptive_representation_item.description = \ 'steady rest not used' ) }                     </pre>



**Table 11 — Mapping table for process data for turning UoF (continued)**

Application element	AIM element	Source	Rules	Reference path
<p>follow_rest</p> <p>#1: if value is true</p> <p>#2: if value is false (mapping may also be omitted if value is false)</p>	<p>descriptive_representation_item.-description</p>	<p>10303-45</p>		<pre> maching_functions &lt;=   action_method characterized_action_definition = action_method characterized_action_definition &lt;-   action_property_definition { action_property.name = 'follow rest' }   action_property &lt;- action_property_representation.property action_property_representation action_property_representation.representation -&gt;   representation   representation.items[i] -&gt;   representation_item =&gt;   descriptive_representation_item   descriptive_representation_item.description { #1: (descriptive_representation_item.description = \ 'follow rest used' ) #2: (descriptive_representation_item.description = \ 'follow rest not used' ) } </pre>
<p>TURNING_MACHINING_OPERATION</p>	<p>turning_type_operation</p>	<p>10303-238</p>		<pre> turning_type_operation &lt;=   machining_operation &lt;=   action_method </pre>
<p>turning_type_operation to approach_retract_strategy (as approach)</p>	<p>PATH</p>			<pre> turning_type_operation &lt;=   machining_operation &lt;=   action_method &lt;-   action_method_relationship.relatng_method   { action_method_relationship =&gt;   machining_strategy_relationship }   { action_method_relationship.name = 'approach' }   action_method_relationship.related_method -&gt;   action_method =&gt;   machining_strategy =&gt;   machining_approach_retract_strategy </pre>

**Table 11 — Mapping table for process data for turning UoF (continued)**

Application element	AIM element	Source	Rules	Reference path
turning_type_operation to approach_retract_strategy (as retract)	PATH			turning_type_operation <= machining_operation <= action_method <- action_method_relationship.relatiing_method action_method_relationship { action_method_relationship => machining_strategy_relationship } { action_method_relationship.name = 'retract' } action_method_relationship.related_method -> action_method => machining_strategy => machining_approach_retract_strategy
turning_type_operation to turning_machining_strategy (as its_machining_strategy)	PATH			turning_type_operation <= machining_operation <= action_method <- action_method_relationship.relatiing_method action_method_relationship { action_method_relationship => machining_strategy_relationship } { action_method_relationship.name = 'machining' } action_method_relationship.related_method -> action_method => machining_strategy => turning_type_strategy
TURNING_MACHINING_STRATEGY	turning_type_strategy	10303-238		turning_type_strategy <= machining_strategy <= action_method

**Table 11 — Mapping table for process data for turning UoF (continued)**

Application element	AIM element	Source	Rules	Reference path
overcut_length	length_measure_with_unit	10303-41		turning_type_strategy <= machining_strategy <= action_method characterized_action_definition = action_method characterized_action_definition <- action_property.definition { action_property.name = 'overcut length' } action_property <- action_property_representation.property action_property_representation action_property_representation.representation -> representation representation.items[i] -> representation_item => measure_representation_item <= measure_with_unit => length_measure_with_unit

**Table 11 — Mapping table for process data for turning UoF (continued)**

Application element	AIM element	Source	Rules	Reference path
<p>allow_multiple_passes</p> <p>#1: if value is true (mapping may also be omitted if value is true)</p> <p>#2: if value is false</p>	<p>descriptive_representation_item.-description</p>	<p>10303-45</p>		<pre> turning_type_strategy &lt;=   machining_strategy &lt;=     action_method characterized_action_definition = action_method characterized_action_definition &lt;-   action_property.definition   { action_property.name = 'multiple passes' }   action_property &lt;-     action_property_representation.property   action_property_representation   action_property_representation.representation -&gt;     representation   representation.items[i] -&gt;     representation_item =&gt;       descriptive_representation_item   descriptive_representation_item.description   { #1: (descriptive_representation_item.description = \     'multiple passes allowed' )     #2: (descriptive_representation_item.description = \     'multiple passes not allowed' ) } </pre>

**Table 11 — Mapping table for process data for turning UoF (continued)**

Application element	AIM element	Source	Rules	Reference path
cutting_depth	length_measure_with_unit	10303-41		<pre> turning_type_strategy &lt;= machining_strategy &lt;=   action_method characterized_action_definition = action_method characterized_action_definition &lt;-   action_property.definition   { action_property.name = 'cutting depth' }   action_property &lt;- action_property_representation.property action_property_representation action_property_representation.representation -&gt;   representation   representation.items[i] -&gt;   representation_item =&gt;   compound_representation_item   compound_representation_item.item_element -&gt;   compound_item_definition   compound_item_definition = list_representation_item   list_representation_item[i] -&gt;   representation_item =&gt;   measure_representation_item &lt;=   measure_with_unit =&gt;   length_measure_with_unit                     </pre>

**Table 11 — Mapping table for process data for turning UoF (continued)**

Application element	AIM element	Source	Rules	Reference path
variable_feedrate	ratio_measure_with_unit	10303-41		<pre> turning_type_strategy &lt;=   machining_strategy &lt;=     action_method characterized_action_definition = action_method characterized_action_definition &lt;-   action_property.definition { action_property.name = 'variable feedrate' }   action_property &lt;-     action_property_representation.property   action_property_representation   action_property_representation.representation -&gt;     { representation =&gt;       machining_feed_speed_representation }     representation     { representation.name = 'relative speed' }     representation.items[i] -&gt;       { representation_item.name = 'relative speed' }       representation_item =&gt;         measure_representation_item &lt;=           measure_with_unit =&gt;             ratio_measure_with_unit </pre>
TURNING_TECHNOLOGY	machining_technology	10303-238		<pre> machining_technology &lt;=   action_method { action_method.description = 'turning' } </pre>

**Table 11 — Mapping table for process data for turning UoF (continued)**

Application element	AIM element	Source	Rules	Reference path
spindle_speed	PATH			<pre> machining_technology &lt;=   action_method characterized_action_definition = action_method characterized_action_definition &lt;-   action_property_definition { action_property.name = 'spindle' } action_property &lt;-   action_property_representation.property action_property_representation action_property_representation.representation -&gt; { (representation.name = 'spindle speed')   (representation.name = 'cutting speed') } representation =&gt; machining_spindle_speed_representation                     </pre>
feed_per_revolution	measure_with_unit	10303-41		<pre> machining_technology &lt;=   action_method characterized_action_definition = action_method characterized_action_definition &lt;-   action_property_definition { action_property.name = 'feedrate' } action_property &lt;-   action_property_representation.property action_property_representation action_property_representation.representation -&gt; { representation =&gt;   machining_feed_speed_representation } representation { representation.name = 'feed per revolution' } representation.items[i] -&gt; { representation_item.name = 'feed per revolution' } representation_item =&gt;   measure_representation_item &lt;=   measure_with_unit                     </pre>

**Table 11 — Mapping table for process data for turning UoF (continued)**

Application element	AIM element	Source	Rules	Reference path
<p>sync_spindle_and_z_feed</p> <p>#1: if value is true</p> <p>#2: if value is false (mapping may also be omitted if value is false)</p>	<p>descriptive_representation_item.-description</p>	<p>10303-45</p>		<pre> machining_technology &lt;=   action_method characterized_action_definition = action_method characterized_action_definition &lt;-   action_property_definition { action_property.name = 'synchronize spindle with z feed' }   action_property &lt;-     action_property_representation.property   action_property_representation   action_property_representation.representation -&gt;     representation   representation.items[i] -&gt;     representation_item =&gt;       descriptive_representation_item   descriptive_representation_item.description { #1: (descriptive_representation_item.description = \ 'synchronized' ) #2: (descriptive_representation_item.description = \ 'not synchronized' ) }</pre>



**Table 11 — Mapping table for process data for turning UoF (continued)**

Application element	AIM element	Source	Rules	Reference path
<p>inhibit_feedrate_override</p> <p>#1: if value is true</p> <p>#2: if value is false (mapping may also be omitted if value is false)</p>	<p>descriptive_representation_item.-description</p>	<p>10303-45</p>		<pre> machining_technology &lt;=   action_method characterized_action_definition = action_method characterized_action_definition &lt;-   action_property_definition { action_property.name = 'inhibit feedrate override' }   action_property &lt;-     action_property_representation.property   action_property_representation   action_property_representation.representation -&gt;     representation   representation.items[i] -&gt;     representation_item =&gt;       descriptive_representation_item   descriptive_representation_item.description { #1: (descriptive_representation_item.description = \   'override not allowed' )   #2: (descriptive_representation_item.description = \   'override allowed' ) }</pre>

**Table 11 — Mapping table for process data for turning UoF (continued)**

Application element	AIM element	Source	Rules	Reference path
inhibit_spindle_override #1: if value is true #2: if value is false (mapping may also be omitted if value is false)	descriptive_representation_item.-description	10303-45		<pre> machining_technology &lt;=   action_method characterized_action_definition = action_method characterized_action_definition &lt;-   action_property_definition { action_property.name = 'inhibit spindle override' }   action_property &lt;-   action_property_representation.property   action_property_representation   action_property_representation.representation -&gt;   representation   representation.items[i] -&gt;   representation_item =&gt;   descriptive_representation_item   descriptive_representation_item.description { #1: (descriptive_representation_item.description = \ 'override not allowed' ) #2: (descriptive_representation_item.description = \ 'override allowed' ) }</pre>
turning_technology_to_adaptive_control (as its_adaptive_control)	PATH			<pre> machining_technology &lt;=   action_method &lt;-   action_method_relationship.relatng_method   action_method_relationship   { action_method_relationship =&gt;   machining_adaptive_control_relationship }   action_method_relationship.related_method -&gt;   action_method =&gt;   machining_technology</pre>
TURNING_WORKINGSTEP	machining_workingstep	10303-238		<pre> machining_workingstep &lt;=   machining_process_executable &lt;=   action_method   { action_method.description = 'turning' }</pre>

**Table 11 — Mapping table for process data for turning UoF (continued)**

Application element	AIM element	Source	Rules	Reference path
turning_workingstep to manufacturing_feature (as its_features)	PATH			<pre> machining_workingstep &lt;= machining_process_executable &lt;=   action_method &lt;- action_method_relationship.relatng_method   action_method_relationship { action_method_relationship =&gt; machining_feature_relationship } machining_feature_sequence_relationship } action_method_relationship.related_method -&gt; { action_method =&gt; machining_process_executable =&gt; machining_feature_process }   action_method &lt;-   action_chosen_method   { action.name = 'machining' }   action =&gt;   property_process &lt;-   process_property_association.process   process_property_association   process_property_association.property_or_shape -&gt;   property_or_shape_select   property_or_shape_select = shape_definition   shape_definition = shape_aspect   shape_aspect </pre> <p>See NOTE 18</p>

**Table 11 — Mapping table for process data for turning UoF (continued)**

Application element	AIM element	Source	Rules	Reference path
turning_workingstep to turning_machining_operation (as its_operation)	PATH			<pre> machining_workingstep &lt;= machining_process_executable &lt;= action_method &lt;- action_method_relationship.relatng_method action_method_relationship { action_method_relationship =&gt; machining_operation_relationship } action_method_relationship.related_method -&gt; action_method =&gt; machining_operation =&gt; turning_type_operation </pre>
turning_workingstep to in_process_geometry (as its_effect)	PATH			<pre> machining_workingstep &lt;= machining_process_executable &lt;= action_method characterized_action_definition = action_method characterized_action_definition &lt;- action_property.definition action_property </pre>
UNIDIRECTIONAL_TURNING	turning_type_strategy	10303-238		<pre> turning_type_strategy &lt;= machining_strategy &lt;= action_method { action_method.description = 'unidirectional' } </pre>

**Table 11 — Mapping table for process data for turning UoF (continued)**

Application element	AIM element	Source	Rules	Reference path
feed_direction	direction	10303-42		<pre> turning_type_strategy &lt;= machining_strategy &lt;= action_method characterized_action_definition = action_method characterized_action_definition &lt;- action_property.definition { action_property.name = 'feed direction' } action_property &lt;- action_property_representation.property action_property_representation action_property_representation.representation -&gt; representation representation.items[i] -&gt; representation_item =&gt; geometric_representation_item =&gt; direction                     </pre>
back_path_direction	direction	10303-42		<pre> turning_type_strategy &lt;= machining_strategy &lt;= action_method characterized_action_definition = action_method characterized_action_definition &lt;- action_property.definition { action_property.name = 'back path direction' } action_property &lt;- action_property_representation.property action_property_representation action_property_representation.representation -&gt; representation representation.items[i] -&gt; representation_item =&gt; geometric_representation_item =&gt; direction                     </pre>

**Table 11 — Mapping table for process data for turning UoF (continued)**

Application element	AIM element	Source	Rules	Reference path
lift_direction	direction	10303-42		<pre> turning_type_strategy &lt;= machining_strategy &lt;= action_method characterized_action_definition = action_method characterized_action_definition &lt;- action_property.definition { action_property.name = 'lift direction' } action_property &lt;- action_property_representation.property action_property_representation action_property_representation.representation -&gt; representation representation.items[i] -&gt; representation_item =&gt; geometric_representation_item =&gt; direction                     </pre>
stepover_direction	direction	10303-42		<pre> turning_type_strategy &lt;= machining_strategy &lt;= action_method characterized_action_definition = action_method characterized_action_definition &lt;- action_property.definition { action_property.name = 'stepover direction' } action_property &lt;- action_property_representation.property action_property_representation action_property_representation.representation -&gt; representation representation.items[i] -&gt; representation_item =&gt; geometric_representation_item =&gt; direction                     </pre>

**Table 11 — Mapping table for process data for turning UoF (continued)**

Application element	AIM element	Source	Rules	Reference path
lift_height	length_measure_with_unit	10303-41		turning_type_strategy <= machining_strategy <= action_method characterized_action_definition = action_method characterized_action_definition <- action_property.definition { action_property.name = 'lift height' } action_property <- action_property_representation.property action_property_representation action_property_representation.representation -> representation representation.items[i] -> representation_item => measure_representation_item <= measure_with_unit => length_measure_with_unit
lift_feed	machining_feed_speed_- representation	10303-238		turning_type_strategy <= machining_strategy <= action_method characterized_action_definition = action_method characterized_action_definition <- action_property.definition { action_property.name = 'lift feedrate' } action_property <- action_property_representation.property action_property_representation action_property_representation.representation -> { (representation.name = 'feed speed') (representation.name = 'feed per revolution') } representation => machining_feed_speed_representation

**Table 11 — Mapping table for process data for turning UoF (continued)**

Application element	AIM element	Source	Rules	Reference path
stepover_feed	machining_feed_speed_- representation	10303-238		<pre> turning_type_strategy &lt;= machining_strategy &lt;=   action_method characterized_action_definition = action_method characterized_action_definition &lt;-   action_property.definition { action_property.name = 'stepover feedrate' }   action_property &lt;-   action_property_representation.property   action_property_representation action_property_representation.representation -&gt; { (representation.name = 'feed speed') (representation.name = 'feed per revolution') }   representation =&gt;   machining_feed_speed_representation                     </pre>



Table 12 — Mapping table for cutting tools for turning UoF

Application element	AIM element	Source	Rules	Reference path
CHAMFERED_CORNER	machining_cutting_corner_- representation	10303-238		machining_cutting_corner_representation <= representation { representation.name = 'chamfered corner' }
corner_chamfer_angle	plane_angle_measure_with_unit	10303-41		machining_cutting_corner_representation <= representation representation.items[] -> { representation_item.name = 'chamfer angle' } representation_item => measure_representation_item <= measure_with_unit => plane_angle_measure_with_unit
corner_chamfer_length	length_measure_with_unit	10303-41		machining_cutting_corner_representation <= representation representation.items[] -> { representation_item.name = 'chamfer length' } representation_item => measure_representation_item <= measure_with_unit => length_measure_with_unit
corner_chamfer_width	length_measure_with_unit	10303-41		machining_cutting_corner_representation <= representation representation.items[] -> { representation_item.name = 'chamfer width' } representation_item => measure_representation_item <= measure_with_unit => length_measure_with_unit
CORNER_TRANSITION	machining_cutting_corner_- representation	10303-238		machining_cutting_corner_representation <= representation

**Table 12 — Mapping table for cutting tools for turning UoF (continued)**

Application element	AIM element	Source	Rules	Reference path
corner_identity	count_measure	10303-41		<pre> machining_cutting_corner_representation &lt;=   representation   representation.items[i] -&gt;   { representation_item.name = 'corner identity' }   representation_item =&gt;   measure_representation_item &lt;=   measure_with_unit =&gt;   measure_with_unit.value_component -&gt;   measure_value   measure_value = count_measure   count_measure                     </pre>
corner_transition_to_chamfered_corner, rounded_corner, or profiled_corner (as transition)	IDENTICAL MAPPING			
CUTTING_EDGE_PROPERTIES	machining_cutting_component	10303-238		<pre> machining_cutting_component &lt;=   [action_resource]   [characterized_object]   { action_resource.kind -&gt;   action_resource_type   action_resource_type.name = 'turning cutting edge' }                     </pre>
cutting_edge_properties_to_material (as its_material)	PATH			<pre> machining_cutting_component &lt;=   characterized_object   characterized_definition = characterized_object   characterized_definition &lt;-   material_designation.definitions[i]   material_designation                     </pre>

**Table 12 — Mapping table for turning UoF (continued)**

Application element	AIM element	Source	Rules	Reference path
<p>expected_tool_life</p>	<p>time_measure_with_unit</p>	<p>10303-41</p>		<pre> machining_cutting_component &lt;=   action_resource characterized_resource_definition = action_resource characterized_resource_definition &lt;-   resource_property.resource { resource_property.name = 'expected life' } resource_property &lt;- resource_property_representation.property resource_property_representation resource_property_representation.representation -&gt;   representation representation.items[i] -&gt;   representation_item =&gt;   measure_representation_item &lt;=   measure_with_unit =&gt;   time_measure_with_unit </pre>
<p>cutting_edge_properties_to_milling_technology (as its_technology)</p>	<p>PATH</p>			<pre> machining_cutting_component &lt;=   action_resource &lt;-   requirement_for_action_resource.resources[i]   requirement_for_action_resource &lt;=   action_resource_requirement   { action_resource_requirement.kind -&gt;     resource_requirement_type     resource_requirement_type.name = 'cutting component' }   action_resource_requirement.operations[i] -&gt;   characterized_action_definition   characterized_action_definition = action_method   action_method =&gt;   machining_technology </pre>

**Table 12 — Mapping table for cutting tools for turning UoF (continued)**

Application element	AIM element	Source	Rules	Reference path
cutting_edge_length	length_measure_with_unit	10303-41		<pre> machining_cutting_component &lt;=   action_resource characterized_resource_definition = action_resource characterized_resource_definition &lt;-   resource_property.resource { resource_property.name = 'cutting edge length' }   resource_property &lt;-     resource_property_representation.property   resource_property_representation resource_property_representation-&gt;   representation   representation.items[i] -&gt;   representation_item =&gt;   measure_representation_item &lt;=   measure_with_unit =&gt;   length_measure_with_unit </pre>
tool_cutting_edge_angle	plane_angle_measure_with_unit	10303-41		<pre> machining_cutting_component &lt;=   action_resource characterized_resource_definition = action_resource characterized_resource_definition &lt;-   resource_property.resource { resource_property.name = 'cutting edge angle' }   resource_property &lt;-     resource_property_representation.property   resource_property_representation resource_property_representation-&gt;   representation   representation.items[i] -&gt;   representation_item =&gt;   measure_representation_item &lt;=   measure_with_unit =&gt;   plane_angle_measure_with_unit </pre>

**Table 12 — Mapping table for cutting tools for turning UoF (continued)**

Application element	AIM element	Source	Rules	Reference path
cutting_edge_properties to corner_transition (as corner_transitions)	PATH			<pre> machining_cutting_component &lt;=   action_resource characterized_resource_definition = action_resource characterized_resource_definition &lt;-   resource_property.resource { resource_property.name = 'corner transitions' } resource_property &lt;-   resource_property_representation.property resource_property_representation resource_property_representation-&gt;   representation =&gt;   machining_cutting_corner_representation </pre> <p>See NOTE 22</p>
tool_included_angle	plane_angle_measure_with_unit	10303-41		<pre> machining_cutting_component &lt;=   action_resource characterized_resource_definition = action_resource characterized_resource_definition &lt;-   resource_property.resource { resource_property.name = 'tool included angle' } resource_property &lt;-   resource_property_representation.property resource_property_representation resource_property_representation-&gt;   representation   representation.items[j] -&gt;   representation_item =&gt;   measure_representation_item &lt;=   measure_with_unit =&gt;   plane_angle_measure_with_unit </pre>

**Table 12 — Mapping table for cutting tools for turning UoF (continued)**

Application element	AIM element	Source	Rules	Reference path
maximum_side_cutting_depth	length_measure_with_unit	10303-41		<pre> machining_cutting_component &lt;=   action_resource characterized_resource_definition = action_resource characterized_resource_definition &lt;-   resource_property.resource { resource_property.name = 'maximum side cutting depth' }   resource_property &lt;- resource_property_representation.property resource_property_representation resource_property_representation.representation -&gt;   representation representation.items[i] -&gt;   representation_item =&gt; measure_representation_item &lt;=   measure_with_unit =&gt; length_measure_with_unit                     </pre>
maximum_end_cutting_depth	length_measure_with_unit	10303-41		<pre> machining_cutting_component &lt;=   action_resource characterized_resource_definition = action_resource characterized_resource_definition &lt;-   resource_property.resource { resource_property.name = 'maximum end cutting depth' }   resource_property &lt;- resource_property_representation.property resource_property_representation resource_property_representation.representation -&gt;   representation representation.items[i] -&gt;   representation_item =&gt; measure_representation_item &lt;=   measure_with_unit =&gt; length_measure_with_unit                     </pre>

**Table 12 — Mapping table for cutting tools for turning UoF (continued)**

Application element	AIM element	Source	Rules	Reference path
GENERAL_TURNING_TOOL	machining_tool	10303-238		<pre> machining_tool &lt;= action_resource { action_resource.description = 'general turning tool' } </pre>
GROOVING_TOOL	machining_tool	10303-238		<pre> machining_tool &lt;= action_resource { action_resource.description = 'grooving tool' } </pre>
cutting_width	length_measure_with_unit	10303-41		<pre> machining_tool &lt;= action_resource characterized_resource_definition = action_resource characterized_resource_definition &lt;- resource_property.resource { resource_property.name = 'tool body' } resource_property &lt;- resource_property_representation.property resource_property_representation resource_property_representation.representation -&gt; { representation =&gt; machining_tool_body_representation } representation representation.items[i] -&gt; { representation_item.name = 'cutting width' } representation_item =&gt; measure_representation_item &lt;= measure_with_unit =&gt; length_measure_with_unit </pre>

**Table 12 — Mapping table for turning UoF (continued)**

Application element	AIM element	Source	Rules	Reference path
maximum_grooving_depth	length_measure_with_unit	10303-41		<pre> machining_tool &lt;=   action_resource characterized_resource_definition = action_resource characterized_resource_definition &lt;-   resource_property.resource { resource_property.name = 'tool body' } resource_property &lt;-   resource_property_representation.property resource_property_representation resource_property_representation.representation -&gt; { representation =&gt;   machining_tool_body_representation }   representation   representation.items[i] -&gt; { representation_item.name = 'maximum grooving depth' }   representation_item =&gt;   measure_representation_item &lt;=   measure_with_unit =&gt;   length_measure_with_unit </pre>



**Table 12 — Mapping table for cutting tools for turning UoF (continued)**

Application element	AIM element	Source	Rules	Reference path
corner_radius	length_measure_with_unit	10303-41		<pre> machining_tool &lt;=   action_resource characterized_resource_definition = action_resource characterized_resource_definition &lt;-   resource_property.resource { resource_property.name = 'tool body' } resource_property &lt;-   resource_property_representation.property resource_property_representation resource_property_representation.representation -&gt; { representation =&gt;   machining_tool_body_representation }   representation   representation.items[] -&gt; { representation_item.name = 'corner radius' }   representation_item =&gt;   measure_representation_item &lt;=   measure_with_unit =&gt;   length_measure_with_unit </pre>

**Table 12 — Mapping table for cutting tools for turning UoF (continued)**

Application element	AIM element	Source	Rules	Reference path
maximum_axial_grooving_diameter	length_measure_with_unit	10303-41		<pre> machining_tool &lt;=   action_resource characterized_resource_definition = action_resource characterized_resource_definition &lt;-   resource_property.resource { resource_property.name = 'tool body' } resource_property &lt;-   resource_property_representation.property resource_property_representation resource_property_representation.representation -&gt; { representation =&gt;   machining_tool_body_representation }   representation   representation.items[i] -&gt; {representation_item.name = 'maximum axial grooving diameter'}   representation_item =&gt;   measure_representation_item &lt;=   measure_with_unit =&gt;   length_measure_with_unit </pre>

**Table 12 — Mapping table for turning UoF (continued)**

Application element	AIM element	Source	Rules	Reference path
minimum_axial_grooving_diameter	length_measure_with_unit	10303-41		<pre> machining_tool &lt;=   action_resource characterized_resource_definition = action_resource characterized_resource_definition &lt;-   resource_property.resource { resource_property.name = 'tool body' } resource_property &lt;-   resource_property_representation.property resource_property_representation resource_property_representation.representation -&gt; { representation =&gt;   machining_tool_body_representation }   representation   representation.items[i] -&gt; {representation_item.name = 'minimum axial grooving diameter'}   representation_item =&gt;   measure_representation_item &lt;=   measure_with_unit =&gt;   length_measure_with_unit </pre>
KNURLING_TOOL	machining_tool	10303-238		<pre> machining_tool &lt;=   action_resource { action_resource.description = 'knurling tool' } </pre>

**Table 12 — Mapping table for cutting tools for turning UoF (continued)**

Application element	AIM element	Source	Rules	Reference path
knurl_pattern	descriptive_representation_item.-description	10303-45		<pre> machining_tool &lt;=   action_resource   characterized_resource_definition = action_resource   characterized_resource_definition &lt;-     resource_property.resource     { resource_property.name = 'tool body' }   resource_property &lt;-     resource_property_representation.property     resource_property_representation     resource_property_representation.representation -&gt;     { representation =&gt;       machining_tool_body_representation }       representation       representation.items[i] -&gt;       { representation_item.name = 'knurl pattern' }       representation_item =&gt;       descriptive_representation_item       descriptive_representation_item.description       { (descriptive_representation_item.description = 'straight' )         (descriptive_representation_item.description = 'diagonal' )         (descriptive_representation_item.description = 'diamond' ) } </pre>

**Table 12 — Mapping table for cutting tools for turning UoF (continued)**

Application element	AIM element	Source	Rules	Reference path
cutting_length	length_measure_with_unit	10303-41		<pre> machining_tool &lt;=   action_resource characterized_resource_definition = action_resource characterized_resource_definition &lt;-   resource_property.resource { resource_property.name = 'tool body' } resource_property &lt;-   resource_property_representation.property resource_property_representation resource_property_representation.representation -&gt; { representation =&gt;   machining_tool_body_representation }   representation   representation.items[] -&gt; { representation_item.name = 'cutting length' }   representation_item =&gt;   measure_representation_item &lt;=   measure_with_unit =&gt;   length_measure_with_unit </pre>

**Table 12 — Mapping table for cutting tools for turning UoF (continued)**

Application element	AIM element	Source	Rules	Reference path
angle	plane_angle_measure_with_unit	10303-41		<pre> machining_tool &lt;=   action_resource characterized_resource_definition = action_resource characterized_resource_definition &lt;-   resource_property.resource { resource_property.name = 'tool body' } resource_property &lt;-   resource_property_representation.property resource_property_representation resource_property_representation.representation -&gt; { representation =&gt;   machining_tool_body_representation }   representation   representation.items[i] -&gt; { representation_item.name = 'cutting angle' }   representation_item =&gt;   measure_representation_item &lt;=   measure_with_unit =&gt;   plane_angle_measure_with_unit </pre>

**Table 12 — Mapping table for cutting tools for turning UoF (continued)**

Application element	AIM element	Source	Rules	Reference path
pitch	length_measure_with_unit	10303-41		<pre> machining_tool &lt;=   action_resource characterized_resource_definition = action_resource characterized_resource_definition &lt;-   resource_property.resource { resource_property.name = 'tool body' } resource_property &lt;-   resource_property_representation.property resource_property_representation resource_property_representation.representation -&gt; { representation =&gt;   machining_tool_body_representation }   representation   representation.items[i] -&gt; { representation_item.name = 'cutting pitch' }   representation_item =&gt;   measure_representation_item &lt;=   measure_with_unit =&gt;   length_measure_with_unit </pre>
PROFILED_CORNER	machining_cutting_corner_ - representation	10303-238		<pre> machining_cutting_corner_representation &lt;=   representation { representation.name = 'profiled corner' } </pre>

**Table 12 — Mapping table for cutting tools for turning UoF (continued)**

Application element	AIM element	Source	Rules	Reference path
profiled_corner to open_profile (as transition_profile)	PATH			<pre> machining_cutting_corner_representation &lt;=   representation &lt;-   property_definition_representation.used_representation   property_definition_representation   property_definition_representation.definition -&gt;   represented_definition   represented_definition = shape_aspect   shape_aspect   (linear_profile)   (open_path_profile)   (partial_circular_profile)   (rounded_u_profile)   (square_u_profile)   (tee_profile)   (vee_profile)                     </pre>
ROUNDED_CORNER	machining_cutting_corner_ - representation	10303-238		<pre> machining_cutting_corner_representation &lt;=   representation   { representation.name = 'rounded corner' }                     </pre>
corner_radius	length_measure_with_unit	10303-41		<pre> machining_cutting_corner_representation &lt;=   representation   { representation.items[i] -&gt;     representation_item.name = 'radius' }   representation_item =&gt;   measure_representation_item &lt;=   measure_with_unit =&gt;   length_measure_with_unit                     </pre>
TURNING_MACHINE_CUTTING_ - TOOL	machining_tool	10303-238		<pre> machining_tool &lt;=   action_resource   { action_resource.kind -&gt;     action_resource_type     action_resource_type.name = 'turning cutting tool' }                     </pre>



**Table 12 — Mapping table for cutting tools for turning UoF (continued)**

Application element	AIM element	Source	Rules	Reference path
functional_length	length_measure_with_unit	10303-41		<pre> machining_tool &lt;=   action_resource characterized_resource_definition = action_resource characterized_resource_definition &lt;-   resource_property.resource { resource_property.name = 'tool body' } resource_property &lt;-   resource_property_representation.property resource_property_representation resource_property_representation.representation -&gt; { representation =&gt;   machining_tool_body_representation }   representation   representation.items[] -&gt; { representation_item.name = 'functional length' }   representation_item =&gt;   measure_representation_item &lt;=   measure_with_unit =&gt;   length_measure_with_unit </pre>

**Table 12 — Mapping table for cutting tools for turning UoF (continued)**

Application element	AIM element	Source	Rules	Reference path
f_dimension	length_measure_with_unit	10303-41		<pre> machining_tool &lt;=   action_resource characterized_resource_definition = action_resource characterized_resource_definition &lt;-   resource_property.resource { resource_property.name = 'tool body' } resource_property &lt;-   resource_property_representation.property resource_property_representation resource_property_representation.representation -&gt; { representation =&gt;   machining_tool_body_representation }   representation   representation.items[i] -&gt; { representation_item.name = 'f dimension' }   representation_item =&gt;   measure_representation_item &lt;=   measure_with_unit =&gt;   length_measure_with_unit </pre>

**Table 12 — Mapping table for cutting tools for turning UoF (continued)**

Application element	AIM element	Source	Rules	Reference path
minimum_cutting_diameter	length_measure_with_unit	10303-41		<pre> machining_tool &lt;=   action_resource characterized_resource_definition = action_resource characterized_resource_definition &lt;-   resource_property.resource { resource_property.name = 'tool body' } resource_property &lt;-   resource_property_representation.property resource_property_representation resource_property_representation.representation -&gt; { representation =&gt;   machining_tool_body_representation }   representation   representation.items[i] -&gt; { representation_item.name = 'minimum cutting diameter' }   representation_item =&gt;   measure_representation_item &lt;=   measure_with_unit =&gt;   length_measure_with_unit </pre>

**Table 12 — Mapping table for cutting tools for turning UoF (continued)**

Application element	AIM element	Source	Rules	Reference path
a_dimension_on_f	length_measure_with_unit	10303-41		<pre> machining_tool &lt;=   action_resource characterized_resource_definition = action_resource characterized_resource_definition &lt;-   resource_property.resource { resource_property.name = 'tool body' } resource_property &lt;-   resource_property_representation.property resource_property_representation resource_property_representation.representation -&gt; { representation =&gt;   machining_tool_body_representation }   representation   representation.items[] -&gt; { representation_item.name = 'a dimension on f' }   representation_item =&gt;   measure_representation_item &lt;=   measure_with_unit =&gt;   length_measure_with_unit </pre>

**Table 12 — Mapping table for cutting tools for turning UoF (continued)**

Application element	AIM element	Source	Rules	Reference path
a_dimension_on_if	length_measure_with_unit	10303-41		<pre> machining_tool &lt;= action_resource characterized_resource_definition = action_resource characterized_resource_definition &lt;- resource_property.resource { resource_property.name = 'tool body' } resource_property &lt;- resource_property_representation.property resource_property_representation resource_property_representation.representation -&gt; { representation =&gt; machining_tool_body_representation } representation representation.items[] -&gt; { representation_item.name = 'a dimension on lf' } representation_item =&gt; measure_representation_item &lt;= measure_with_unit =&gt; length_measure_with_unit </pre>
turning_machine_cutting_tool to cutting_edge_properties (as cutting_edge)	PATH			<pre> machining_tool &lt;= action_resource &lt;- action_resource_relationship.relation_resource action_resource_relationship action_resource_relationship.related_resource -&gt; action_resource =&gt; machining_cutting_component </pre>

**Table 12 — Mapping table for cutting tools for turning UoF (continued)**

Application element	AIM element	Source	Rules	Reference path
hand_of_tool	descriptive_representation_item.-description	10303-45		<pre> machining_tool &lt;=   action_resource characterized_resource_definition = action_resource characterized_resource_definition &lt;-   resource_property.resource { resource_property.name = 'tool body' } resource_property &lt;- resource_property_representation.property resource_property_representation resource_property_representation.representation -&gt; { representation =&gt;   machining_tool_body_representation } representation representation.items[i] -&gt; representation_item.name = 'hand of cut' } representation_item =&gt; descriptive_representation_item descriptive_representation_item.description { (descriptive_representation_item.description = 'left' ) (descriptive_representation_item.description = 'right' ) (descriptive_representation_item.description = 'neutral' ) } </pre>
TURNING_THREADING_TOOL	machining_tool	10303-238		<pre> machining_tool &lt;=   action_resource { action_resource.description = 'turning threading tool' } </pre>

**Table 12 — Mapping table for cutting tools for turning UoF (continued)**

Application element	AIM element	Source	Rules	Reference path
threading_pitch	length_measure_with_unit	10303-41		<pre> machining_tool &lt;=   action_resource characterized_resource_definition = action_resource characterized_resource_definition &lt;-   resource_property.resource { resource_property.name = 'tool body' } resource_property &lt;-   resource_property_representation.property resource_property_representation resource_property_representation.representation -&gt; { representation =&gt;   machining_tool_body_representation }   representation   representation.items[i] -&gt; { representation_item.name = 'thread pitch' }   representation_item =&gt;   measure_representation_item &lt;=   measure_with_unit =&gt;   length_measure_with_unit </pre>

**Table 12 — Mapping table for cutting tools for turning UoF (continued)**

Application element	AIM element	Source	Rules	Reference path
thread_hand	descriptive_representation_item.description	10303-45		<pre> machining_tool &lt;=   action_resource   characterized_resource_definition = action_resource   characterized_resource_definition &lt;-     resource_property.resource     { resource_property.name = 'tool body' }     resource_property &lt;-       resource_property_representation.property       resource_property_representation       resource_property_representation &lt;-&gt;       { representation =&gt;         machining_tool_body_representation }         representation         representation.items[i] -&gt;         { representation_item.name = 'thread hand' }         representation_item =&gt;         descriptive_representation_item         descriptive_representation_item.description         { (descriptive_representation_item.description = 'left' )         (descriptive_representation_item.description = 'right' ) } </pre>





**Table 12 — Mapping table for cutting tools for turning UoF (continued)**

Application element	AIM element	Source	Rules	Reference path
thread_profile	descriptive_representation_item.-description	10303-45		<pre> machining_tool &lt;=   action_resource   characterized_resource_definition = action_resource   characterized_resource_definition &lt;-     resource_property.resource     { resource_property.name = 'tool body' }     resource_property &lt;-       resource_property_representation.property       resource_property_representation       resource_property_representation &lt;-&gt;       { representation =&gt;         machining_tool_body_representation }         representation         representation.items[i] -&gt;         { representation_item.name = 'thread profile' }         representation_item =&gt;         descriptive_representation_item         descriptive_representation_item.description         { (descriptive_representation_item.description = 'full' )           (descriptive_representation_item.description = 'partial' ) } </pre>

**Table 12 — Mapping table for cutting tools for turning UoF (continued)**

Application element	AIM element	Source	Rules	Reference path
thread_form_type	descriptive_representation_item.-description	10303-45		<pre> machining_tool &lt;=   action_resource characterized_resource_definition = action_resource characterized_resource_definition &lt;-   resource_property.resource { resource_property.name = 'tool body' } resource_property &lt;-   resource_property_representation.property resource_property_representation resource_property_representation.representation -&gt; { representation =&gt;   machining_tool_body_representation }   representation   representation.items[] -&gt; { representation_item.name = 'thread form type' }   representation_item =&gt;   descriptive_representation_item   descriptive_representation_item.description </pre>
USER_DEFINED_TURNING_TOOL	machining_tool	10303-238		<pre> machining_tool &lt;=   action_resource { action_resource.description = 'user defined turning tool' } </pre>

**Table 12 — Mapping table for cutting tools for turning UoF (continued)**

Application element	AIM element	Source	Rules	Reference path
identifier	descriptive_representation_item.- description	10303-45		<pre> machining_tool &lt;=   action_resource   characterized_resource_definition = action_resource   characterized_resource_definition &lt;-     resource_property.resource     { resource_property.name = 'tool body' }     resource_property &lt;-       resource_property_representation.property       resource_property_representation       resource_property_representation.representation -&gt;         { representation =&gt;           machining_tool_body_representation }           representation           representation.items[i] -&gt;             { representation_item.name = 'tool identifier' }             representation_item =&gt;               descriptive_representation_item               descriptive_representation_item.description                     </pre>

[Blank page]

**Table 13 — Mapping table for geometric dimensioning and tolerancing UoF**

Application element	AIM element	Source	Rules	Reference path
ANGULAR_LOCATION_DIMENSION #1: If the directed attribute is 'false' #2: If the directed attribute is 'true'	#1:(angular_location) #2:([angular_location] [directed_dimensional_location])	10303-47 10303-47 10303-238		angular_location <= #2: { dimensional_location => directed_dimensional_location } dimensional_location <= shape_aspect_relationship
orientation	placement	10303-42		angular_location <= dimensional_location <= shape_aspect_relationship shape_definition = shape_aspect_relationship shape_definition characterized_definition = shape_definition characterized_definition <= property_definition.definition property_definition <= property_definition.definition property_definition_representation.definition property_definition_representation property_definition_representation.used_representation -> representation representation.items[i] -> { representation_item.name = 'orientation' } representation_item => geometric_representation_item => placement => (axis2_placement_2d) (axis2_placement_3d)
ANGULAR_SIZE_DIMENSION	angular_size	10303-47		

**Table 13 — Mapping table for geometric dimensioning and tolerancing UoF (continued)**

Application element	AIM element	Source	Rules	Reference path
full	descriptive_representation_item.- description	10303-45		angular_size <= dimensional_size dimensional_characteristic = dimensional_size dimensional_characteristic <= dimensional_characteristic_representation.dimensional_size dimensional_characteristic_representation dimensional_characteristic_representation.representation -> shape_dimension_representation.representation <= shape_representation <= representation representation.items[i] -> { representation_item.name = 'angle type' } representation_item => descriptive_representation_item descriptive_representation_item.description { (descriptive_representation_item.description = 'full angle' ) (descriptive_representation_item.description = 'half angle' ) }
major_angle	angular_size.angle_selection	10303-47		
ANGULARITY_TOLERANCE	angularity_tolerance	10303-519		angularity_tolerance <= geometric_tolerance_with_datum_reference <= geometric_tolerance
angularity_tolerance to datum_reference (as reference_datum)	PATH			angularity_tolerance <= geometric_tolerance_with_datum_reference geometric_tolerance_with_datum_reference.datum_system[i] -> datum_reference
CIRCULAR_RUNOUT_TOLERANCE	circular_runout_tolerance	10303-519		circular_runout_tolerance <= geometric_tolerance_with_datum_reference <= geometric_tolerance

**Table 13 — Mapping table for geometric dimensioning and tolerancing UoF (continued)**

Application element	AIM element	Source	Rules	Reference path
angle	measure_with_unit	10303-41		circular_runout_tolerance <= geometric_tolerance_with_datum_reference <= geometric_tolerance <- tolerance_zone.defining_tolerance[i] tolerance_zone <- tolerance_zone_definition.zone tolerance_zone_definition => runout_zone_definition runout_zone_definition.orientation -> runout_zone_orientation runout_zone_orientation.angle -> measure_with_unit
circular_runout_tolerance to datum_reference (as reference_datum)	PATH			circular_runout_tolerance <= geometric_tolerance_with_datum_reference geometric_tolerance_with_datum_reference.datum_system[i] -> datum_reference
COAXIALITY_TOLERANCE	coaxiality_tolerance	10303-519		coaxiality_tolerance <= geometric_tolerance_with_datum_reference <= geometric_tolerance
coaxiality_tolerance to datum_reference (as reference_datum)	PATH			coaxiality_tolerance <= geometric_tolerance_with_datum_reference geometric_tolerance_with_datum_reference.datum_system[i] -> datum_reference
COMMON_DATUM	common_datum	10303-519		common_datum <= datum <= shape_aspect <- shape_aspect.relationship.relatng_shape_aspect shape_aspect.relationship shape_aspect.relationship.related_shape_aspect -> shape_aspect => datum



Table 13 — Mapping table for geometric dimensioning and tolerancing UoF (continued)

Application element	AIM element	Source	Rules	Reference path
CONCENTRICITY_TOLERANCE	concentricity_tolerance	10303-519		concentricity_tolerance <= geometric_tolerance_with_datum_reference <= geometric_tolerance
concentricity_tolerance to datum_reference (as reference_datum)	PATH			concentricity_tolerance <= geometric_tolerance_with_datum_reference geometric_tolerance_with_datum_reference.datum_system[i] -> datum_reference
CURVED_DISTANCE_DIMENSION #1: If the directed attribute is 'false' #2: If the directed attribute is 'true'	#1:(dimensional_location_with_path) #2:( [dimensional_location_with_path] [directed_dimensional_location])	10303-47 10303-47 10303-238		dimensional_location_with_path <= dimensional_location <= #2: { dimensional_location => directed_dimensional_location } shape_aspect relationship { shape_aspect_relationship.name = 'curved distance' }
curved_distance_dimension to measurement_path (as used_path)	PATH			dimensional_location_with_path dimensional_location_with_path.path -> shape_aspect shape_definition = shape_aspect characterized_definition = shape_definition characterized_definition <- property_definition.definition property_definition <- property_definition_representation.definition property_definition_representation property_definition_representation.used_representation -> representation
CURVED_SIZE_DIMENSION	dimensional_size	10303-47		dimensional_size { dimensional_size.name = 'curve length' }
CYLINDRICITY_TOLERANCE	cylindricity_tolerance	10303-519		cylindricity_tolerance <= geometric_tolerance
DATUM	datum	10303-47		

**Table 13 — Mapping table for geometric dimensioning and tolerancing UoF (continued)**

Application element	AIM element	Source	Rules	Reference path
DATUM_DEFINED_BY_DERIVED_SHAPE	[datum] [derived_shape_aspect]	10303-47 10303-47		datum <= shape_aspect => derived_shape_aspect
DATUM_DEFINED_BY_FEATURE	datum	10303-47		
defined_by	datum_feature	10303-47		datum <= shape_aspect <= shape_aspect_relationship.related_shape_aspect shape_aspect_relationship shape_aspect_relationship.relatng_shape_aspect -> shape_aspect => datum_feature See NOTE 23
DATUM_DEFINED_BY_TARGETS	datum	10303-47		
datum_defined_by_targets to datum_target (as defined_by)	PATH			datum <= shape_aspect <= shape_aspect_relationship.related_shape_aspect shape_aspect_relationship shape_aspect_relationship.relatng_shape_aspect -> shape_aspect => datum_target
rule_description	shape_aspect.description	10303-41		datum <= shape_aspect shape_aspect.description
DATUM_REFERENCE	datum_reference	10303-47		
precedence	datum_reference.precedence	10303-47		datum_reference datum_reference.precedence
datum_reference to datum (as referenced_datum)	PATH			datum_reference datum_reference.referenced_datum -> datum

**Table 13 — Mapping table for geometric dimensioning and tolerancing UoF (continued)**

Application element	AIM element	Source	Rules	Reference path
DATUM_TARGET	datum_target	10303-47		
id	datum_target.target_id	10303-47		datum_target datum_target.target_id
DERIVED_GEOMETRY	derived_shape_aspect	10303-47		
derived_from	shape_aspect	10303-41		derived_shape_aspect <= shape_aspect <- shape_aspect_relationship.relatng_shape_aspect shape_aspect_relationship { shape_aspect_relationship => shape_aspect_deriving_relationship} shape_aspect_relationship.related_shape_aspect -> shape_aspect
role #1: if role is 'apex' #2: if role is 'centre of symmetry' #3: if role is 'extension' #4: if role is 'geometric alignment' #5: if role is 'geometric intersection' #6: if role is 'parallel offset' #7: if role is 'perpendicular to' #8: if role is 'tangent' #9: if otherwise	#1: (apex) #2: (centre_of_symmetry) #3: (extension) #4: (geometric_alignment) #5: (geometric_intersection) #6: (parallel_offset) #7: (perpendicular_to) #8: (tangent) #9: (shape_aspect.description)	10303-47 10303-47 10303-47 10303-47 10303-47 10303-47 10303-47 10303-47 10303-41		#1: (derived_shape_aspect => apex) #2: (derived_shape_aspect => centre_of_symmetry) #3: (derived_shape_aspect => extension) #4: (derived_shape_aspect => geometric_alignment) #5: (derived_shape_aspect => geometric_intersection) #6: (derived_shape_aspect => parallel_offset) #7: (derived_shape_aspect => perpendicular_to) #8: (derived_shape_aspect => tangent) #9: (derived_shape_aspect <= shape_aspect shape_aspect.description)

**Table 13 — Mapping table for geometric dimensioning and tolerancing UoF (continued)**

Application element	AIM element	Source	Rules	Reference path
DIAMETER_SIZE_DIMENSION	dimensional_size	10303-47		dimensional_size { dimensional_size.name = 'diameter' }
EXTERNALLY_DEFINED_SIZE_DIMENSION #1: If no measurement_path is specified #2: If a measurement_path is specified	#1: (externally_defined_dimension_definition) #2: ([externally_defined_dimension_definition] [dimensional_size_with_path])	10303-238 10303-238 10303-47		externally_defined_dimension_definition <= #2: { externally_defined_dimension_definition <= dimensional_size => dimensional_size_with_path } externally_defined_item { externally_defined_item.item_id -> source_item source_item = 'external size dimension' } { externally_defined_item.source -> external_source external_source.source_id-> source_item source_item = 'external size dimension specification' }
defining_document	document	10303-41		externally_defined_dimension_definition document_reference_item = \ externally_defined_dimension_definition document_reference_item <- applied_document_reference.items[i] applied_document_reference <= document_reference document_reference.assigned_document -> document { document.description = 'external size dimension specification' }
name	dimensional_size.name	10303-47		externally_defined_dimension_definition <= dimensional_size dimensional_size.name

**Table 13 — Mapping table for geometric dimensioning and tolerancing UoF (continued)**

Application element	AIM element	Source	Rules	Reference path
externally_defined_size_dimension to measurement_path (as used_path)	PATH			dimensional_size_with_path dimensional_size_with_path.path -> shape_aspect shape_definition = shape_aspect characterized_definition = shape_definition characterized_definition <- property_definition.definition property_definition <- property_definition_representation.definition property_definition_representation property_definition_representation.used_representation -> representation
FLATNESS_TOLERANCE	flatness_tolerance	10303-519		flatness_tolerance <= geometric_tolerance
GEOMETRIC_DIMENSION #1: if a location_dimension #2: if a size_dimension	#1:(dimensional_location) #2:(dimensional_size)	10303-47 10303-47		
geometric_dimension to value_with_tolerance or value_range (as dimension_value) #1: if to a value_range #2: if to a value_with_tolerance	PATH			(dimensional_location dimensional_characteristic = dimensional_location) (dimensional_size dimensional_characteristic = dimensional_size) dimensional_characteristic <- dimensional_characteristic_representation.dimension dimensional_characteristic_representation dimensional_characteristic_representation.representation -> #1: (shape_dimension_representation) #2: (shape_dimension_representation <= shape_representation <= representation representation.items[i] -> representation_item => measure_representation_item)

**Table 13 — Mapping table for geometric dimensioning and tolerancing UoF (continued)**

Application element	AIM element	Source	Rules	Reference path
id #1: if a location_dimension #2: if a size_dimension	#1:(shape_aspect_relationship.name) #2:(identification_assignment.-assigned_id)	10303-41 10303-41		#1: (dimensional_location <= shape_aspect_relationship shape_aspect_relationship.name)  #2: (dimensional_size identification_item = dimensional_size identification_item <- applied_identification_assignment.items[i] applied_identification_assignment <= identification_assignment { identification_assignment.role -> identification_role identification_role.name = 'size id' } identification_assignment.assigned_id)
notes	descriptive_representation_item.-description	10303-45		(dimensional_location dimensional_characteristic = dimensional_location) (dimensional_size dimensional_characteristic = dimensional_size) dimensional_characteristic <- dimensional_characteristic_representation.dimension dimensional_characteristic_representation dimensional_characteristic_representation.representation -> shape_dimension_representation <= shape_representation <= representation representation.items[i] -> representation_item { representation_item.name = 'dimensional note' } representation_item => descriptive_representation_item { (descriptive_representation_item.description = 'auxiliary') (descriptive_representation_item.description = 'theoretical') (descriptive_representation_item.description) }
GEOMETRIC_TOLERANCE	geometric_tolerance	10303-47		

Table 13 — Mapping table for geometric dimensioning and tolerancing UoF (continued)

Application element	AIM element	Source	Rules	Reference path
applied_to	shape_aspect	10303-41		geometric_tolerance geometric_tolerance.toleranced_shape_aspect -> shape_aspect
geometric_tolerance_to tolerance_condition (as modification)	PATH			geometric_tolerance => modified_geometric_tolerance modified_geometric_tolerance.modifier
name	geometric_tolerance.name	10303-47		
qualifying_note	geometric_tolerance.description	10303-47		
segment_size	length_measure_with_unit	10303-41		geometric_tolerance => geometric_tolerance_with_defined_unit geometric_tolerance_with_defined_unit.unit_size -> measure_with_unit => length_measure_with_unit
significant_digits	precision_qualifier.precision_value	10303-45		geometric_tolerance geometric_tolerance.magnitude -> measure_with_unit <- measure_qualification.qualified_measure measure_qualification.qualified_measure measure_qualification.qualifiers[i] -> value_qualifier value_qualifier = precision_qualifier precision_qualifier precision_qualifier.precision_value
tolerance_value	measure_with_unit	10303-41		geometric_tolerance geometric_tolerance.magnitude -> measure_with_unit => length_measure_with_unit
GEOMETRIC_TOLERANCE_- RELATIONSHIP	geometric_tolerance_relationship	10303-47		

**Table 13 — Mapping table for geometric dimensioning and tolerancing UoF (continued)**

Application element	AIM element	Source	Rules	Reference path
geometric_tolerance_relationship to geometric_tolerance (as relating)	PATH			geometric_tolerance.relationship geometric_tolerance.relationship-> geometric_tolerance
geometric_tolerance_relationship to geometric_tolerance (as related)	PATH			geometric_tolerance.relationship geometric_tolerance.relationship.related_geometric_tolerance-> geometric_tolerance
relation_type	geometric_tolerance_relationship.- name	10303-47		
HEIGHT_SIZE_DIMENSION #1: If no measurement_path is specified #2: If a measurement_path is specified	#1: (dimensional_size) #2: (dimensional_size_with_path)	10303-47 10303-47		dimensional_size #2: { dimensional_size => dimensional_size_with_path } { dimensional_size.name = 'height' }
height_size_dimension to measurement_path (as used_path)	PATH			dimensional_size_with_path dimensional_size_with_path_path-> shape_aspect shape_definition = shape_aspect characterized_definition = shape_definition characterized_definition <- property_definition.definition property_definition <- property_definition.definition property_definition_representation.definition property_definition_representation property_definition_representation.used_representation-> representation
LENGTH_SIZE_DIMENSION	#1: (dimensional_size) #2: (dimensional_size_with_path)	10303-47 10303-47		dimensional_size #2: { dimensional_size => dimensional_size_with_path } { dimensional_size.name = 'length' }



**Table 13 — Mapping table for geometric dimensioning and tolerancing UoF (continued)**

Application element	AIM element	Source	Rules	Reference path
length_size_dimension to measurement_path (as used_path)	PATH			dimensional_size_with_path dimensional_size_with_path.path -> shape_aspect shape_definition = shape_definition characterized_definition = shape_definition characterized_definition <- property_definition.definition property_definition <- property_definition.definition property_definition_representation.definition property_definition_representation property_definition_representation.used_representation -> representation
LINE_PROFILE_TOLERANCE	line_profile_tolerance	10303-519		line_profile_tolerance <= geometric_tolerance

**Table 13 — Mapping table for geometric dimensioning and tolerancing UoF (continued)**

Application element	AIM element	Source	Rules	Reference path
affected_plane	placement	10303-42		<pre> line_profile_tolerance &lt;= geometric_tolerance &lt;- tolerance_zone.defining_tolerance[i] tolerance_zone &lt;= shape_aspect &lt;- shape_aspect_relationship.relatng_shape_aspect shape_aspect_relationship shape_aspect_relationship.related_shape_aspect-&gt; shape_aspect { shape_aspect.description = 'affected plane' } shape_definition = shape_aspect shape_definition characterized_definition = shape_definition characterized_definition &lt;- property_definition.definition property_definition &lt;- property_definition.representation.definition property_definition.representation property_definition.representation.used_representation -&gt; representation representation.items[i] -&gt; { representation_item.name = 'affected plane' } representation_item =&gt; geometric_representation_item =&gt; placement                     </pre>
line_profile_tolerance to datum_reference (as reference_datum)	PATH			<pre> line_profile_tolerance &lt;= geometric_tolerance =&gt; geometric_tolerance_with_datum_reference geometric_tolerance_with_datum_reference.datum_system[i] -&gt; datum_reference                     </pre>
LINEAR_DISTANCE_DIMENSION #1: If the directed attribute is 'false' #2: If the directed attribute is 'true'	#1:(dimensional_location) #2:(directed_dimensional_location)	10303-47 10303-238		<pre> dimensional_location &lt;= #2: { dimensional_location =&gt; directed_dimensional_location } shape_aspect_relationship { shape_aspect_relationship.name = 'linear distance' }                     </pre>

**Table 13 — Mapping table for geometric dimensioning and tolerancing UoF (continued)**

Application element	AIM element	Source	Rules	Reference path
orientation	placement	10303-42		dimensional_location <= shape_aspect_relationship shape_definition = shape_aspect_relationship shape_definition characterized_definition = shape_definition characterized_definition <= property_definition.definition property_definition <= property_definition_representation.definition property_definition_representation property_definition_representation.used_representation -> representation representation.items[i] -> { representation_item.name = 'orientation' } representation_item => geometric_representation_item => placement => (axis2_placement_2d) (axis2_placement_3d)
LOCATION_DIMENSION #1: If the directed attribute is 'false' #2: If the directed attribute is 'true'	#1:(dimensional_location) #2:(directed_dimensional_location)	10303-47 10303-238		dimensional_location #2: { dimensional_location => directed_dimensional_location }
description	shape_aspect_relationship.- description	10303-41		dimensional_location <= shape_aspect_relationship shape_aspect_relationship.description
directed	IDENTICAL MAPPING			
origin	shape_aspect	10303-41		dimensional_location <= shape_aspect_relationship shape_aspect_relationship.relatng_shape_aspect -> shape_aspect

**Table 13 — Mapping table for geometric dimensioning and tolerancing UoF (continued)**

Application element	AIM element	Source	Rules	Reference path
target	shape_aspect	10303-41		dimensional_location <= shape_aspect_relationship shape_aspect_relationship.related_shape_aspect -> shape_aspect
MEASUREMENT_PATH	representation	10303-43		representation { representation.name = 'measuring direction' }
defined_by	curve	10303-42		representation representation.items[i] -> representation_item => geometric_representation_item => curve => { (pcurve) (surface_curve) }
defined_in	geometric_representation_context	10303-42		representation representation.context_of_items -> representation_context => geometric_representation_context
PARALLELISM_TOLERANCE	parallelism_tolerance	10303-519		parallelism_tolerance <= geometric_tolerance_with_datum_reference <= geometric_tolerance

**Table 13 — Mapping table for geometric dimensioning and tolerancing UoF (continued)**

Application element	AIM element	Source	Rules	Reference path
affected_plane	placement	10303-42		<pre> parallelism_tolerance &lt;= geometric_tolerance_with_datum_reference &lt;= geometric_tolerance &lt;- tolerance_zone.defining_tolerance[i] tolerance_zone &lt;= shape_aspect &lt;- shape_aspect_relationship.relatng_shape_aspect shape_aspect_relationship shape_aspect_relationship.related_shape_aspect-&gt; shape_aspect { shape_aspect.description = 'affected plane' } shape_definition = shape_aspect shape_definition characterized_definition = shape_definition characterized_definition &lt;- property_definition.definition property_definition &lt;- property_definition_representation.definition property_definition_representation property_definition_representation.used_representation -&gt; representation representation.items[i] -&gt; { representation_item.name = 'affected plane' } representation_item =&gt; geometric_representation_item =&gt; placement                     </pre>
parallelism_tolerance to datum_reference (as reference_datum)	PATH			<pre> parallelism_tolerance &lt;= geometric_tolerance_with_datum_reference geometric_tolerance_with_datum_reference.datum_system[i] -&gt; datum_reference                     </pre>
PERPENDICULARITY_TOLERANCE	perpendicularity_tolerance	10303-519		<pre> perpendicularity_tolerance &lt;= geometric_tolerance_with_datum_reference &lt;= geometric_tolerance                     </pre>

**Table 13 — Mapping table for geometric dimensioning and tolerancing UoF (continued)**

Application element	AIM element	Source	Rules	Reference path
affected_plane	placement	10303-42		<pre> perpendicularity_tolerance &lt;= geometric_tolerance_with_datum_reference &lt;= geometric_tolerance &lt;- tolerance_zone.defining_tolerance[i] tolerance_zone &lt;= shape_aspect &lt;- shape_aspect_relationship.relatng_shape_aspect shape_aspect_relationship shape_aspect_relationship.related_shape_aspect-&gt; shape_aspect { shape_aspect.description = 'affected plane' } shape_definition = shape_aspect shape_definition characterized_definition = shape_definition characterized_definition &lt;- property_definition.definition.property_definition &lt;- property_definition.definition.property_definition property_definition_representation.definition property_definition_representation property_definition_representation.used_representation -&gt; representation representation.items[i] -&gt; { representation_item.name = 'affected plane' } representation_item =&gt; geometric_representation_item =&gt; placement                     </pre>
perpendicularity_tolerance to datum_reference (as reference_datum)	PATH			<pre> perpendicularity_tolerance &lt;= geometric_tolerance_with_datum_reference geometric_tolerance_with_datum_reference.datum_system[i] -&gt; datum_reference                     </pre>
PLACED_TARGET	placed_datum_target_feature	10303-238		<pre> placed_datum_target_feature &lt;= datum_target                     </pre>

**Table 13 — Mapping table for geometric dimensioning and tolerancing UoF (continued)**

Application element	AIM element	Source	Rules	Reference path
defined_in	geometric_representation_context	10303-42		<pre> placed_datum_target_feature &lt;=   datum_target &lt;=     shape_aspect   shape_definition = shape_aspect   shape_definition characterized_definition = shape_definition   characterized_definition &lt;-     property_definition.definition   property_definition   represented_definition = property_definition   represented_definition &lt;-     property_definition_representation.definition   {property_definition_representation =&gt;     shape_definition_representation}   property_definition_representation   property_definition_representation.used_representation -&gt;     {representation =&gt;       shape_representation =&gt;         shape_representation_with_parameters}     representation   representation.context_of_items -&gt;     representation_context =&gt;       geometric_representation_context </pre>

**Table 13 — Mapping table for geometric dimensioning and tolerancing UoF (continued)**

Application element	AIM element	Source	Rules	Reference path
parameter_reference	placement	10303-42		<pre> placed_datum_target_feature &lt;=   datum_target &lt;=     shape_aspect   shape_definition = shape_aspect   shape_definition characterized_definition = shape_definition   characterized_definition &lt;-     property_definition.definition   property_definition represented_definition = property_definition   represented_definition &lt;- property_definition_representation.definition   { property_definition_representation =&gt;   shape_definition_representation } property_definition_representation property_definition_representation.used_representation -&gt;   { representation =&gt;   shape_representation =&gt;   shape_representation_with_parameters }   representation   representation.items[i] -&gt;   representation_item =&gt;   { representation_item.name = 'orientation' }   geometric_representation_item =&gt;   placement </pre>
POSITION_TOLERANCE	position_tolerance	10303-519		<pre> position_tolerance &lt;=   geometric_tolerance </pre>



**Table 13 — Mapping table for geometric dimensioning and tolerancing UoF (continued)**

Application element	AIM element	Source	Rules	Reference path
affected_plane	placement	10303-42		<pre> position_tolerance &lt;= geometric_tolerance &lt;- tolerance_zone.defining_tolerance[i] tolerance_zone &lt;= shape_aspect &lt;- shape_aspect_relationship.relatng_shape_aspect shape_aspect_relationship shape_aspect_relationship.related_shape_aspect-&gt; shape_aspect { shape_aspect.description = 'affected plane' } shape_definition = shape_aspect shape_definition characterized_definition = shape_definition characterized_definition &lt;- property_definition.definition property_definition &lt;- property_definition_representation.definition property_definition_representation property_definition_representation.used_representation -&gt; representation representation.items[i] -&gt; { representation_item.name = 'affected plane' } representation_item =&gt; geometric_representation_item =&gt; placement                     </pre>
position_tolerance to datum_reference (as reference_datum)	PATH			<pre> position_tolerance &lt;= geometric_tolerance =&gt; geometric_tolerance_with_datum_reference geometric_tolerance_with_datum_reference.datum_system[i] -&gt; datum_reference                     </pre>
PROJECTION	projected_zone_definition	10303-47		<pre> projected_zone_definition &lt;= tolerance_zone_definition                     </pre>

**Table 13 — Mapping table for geometric dimensioning and tolerancing UoF (continued)**

Application element	AIM element	Source	Rules	Reference path
projection_end	shape_aspect	10303-41		projected_zone_definition projected_zone_definition.projection_end -> shape_aspect
projection_length	measure_with_unit	10303-41		projected_zone_definition projected_zone_definition.projected_length -> measure_with_unit
RADIAL_SIZE_DIMENSION	dimensional_size	10303-47		dimensional_size { dimensional_size.name = 'radius' }
radius_type	descriptive_representation_item - description	10303-45		dimensional_size dimensional_characteristic = dimensional_size dimensional_characteristic <- dimensional_characteristic_representation.dimensional dimensional_characteristic_representation dimensional_characteristic_representation.representation -> shape_dimension_representation <= shape_representation <= representation { representation.items[i] -> representation_item.name = 'radius type' } representation_item => descriptive_representation_item descriptive_representation_item.description { (descriptive_representation_item.description = 'centred' ) (descriptive_representation_item.description = 'adjoining' ) }
ROUNDNESS_TOLERANCE	roundness_tolerance	10303-519		roundness_tolerance <= geometric_tolerance
SINGLE_DATUM	datum	10303-47		
datum_name	datum.identification	10303-47		

**Table 13 — Mapping table for geometric dimensioning and tolerancing UoF (continued)**

Application element	AIM element	Source	Rules	Reference path
single_datum_to_tolerance_condition (as modification)	referenced_modified_datum_modifier	10303-47		datum <- datum_reference.referenced_datum datum_reference datum_reference => referenced_modified_datum referenced_modified_datum_modifier
SIZE_DIMENSION	dimensional_size	10303-47		
applied_to	shape_aspect	10303-41		dimensional_size dimensional_size.applies_to -> shape_aspect
envelope_principle #1: if envelope_principle is true #2: if envelope_principle is false	representation.name	10303-43		dimensional_size dimensional_characteristic = dimensional_size dimensional_characteristic <- dimensional_characteristic_representation.dimensional_size dimensional_characteristic_representation dimensional_characteristic_representation.representation -> shape_dimension_representation <= shape_representation <= representation representation.name #1: ( { representation.name = 'envelope tolerance' } #2: { representation.name = '*' } )
STRAIGHTNESS_TOLERANCE	straightness_tolerance	10303-519		straightness_tolerance <= geometric_tolerance

**Table 13 — Mapping table for geometric dimensioning and tolerancing UoF (continued)**

Application element	AIM element	Source	Rules	Reference path
affected_plane	placement	10303-42		<pre> straightness_tolerance &lt;= geometric_tolerance &lt;- tolerance_zone.defining_tolerance[i] tolerance_zone &lt;= shape_aspect &lt;- shape_aspect_relationship.relatng_shape_aspect shape_aspect_relationship shape_aspect_relationship.related_shape_aspect-&gt; shape_aspect { shape_aspect.description = 'affected plane' } shape_definition = shape_aspect shape_definition characterized_definition = shape_definition characterized_definition &lt;- property_definition.definition property_definition &lt;- property_definition_representation.definition property_definition_representation property_definition_representation.used_representation -&gt; representation representation.items[i] -&gt; { representation_item.name = 'affected plane' } representation_item =&gt; geometric_representation_item =&gt; placement                     </pre>
SURFACE_PROFILE_TOLERANCE	surface_profile_tolerance	10303-519		<pre> surface_profile_tolerance &lt;= geometric_tolerance                     </pre>
surface_profile_tolerance to datum_reference (as reference_datum)	PATH			<pre> surface_profile_tolerance &lt;= geometric_tolerance =&gt; geometric_tolerance_with_datum_reference datum_system[i] -&gt; datum_reference                     </pre>

**Table 13 — Mapping table for geometric dimensioning and tolerancing UoF (continued)**

Application element	AIM element	Source	Rules	Reference path
SYMMETRY_TOLERANCE	symmetry_tolerance	10303-519		<pre> symmetry_tolerance &lt;= geometric_tolerance_with_datum_reference &lt;= geometric_tolerance                     </pre>
affected_plane	placement	10303-42		<pre> symmetry_tolerance &lt;= geometric_tolerance_with_datum_reference &lt;= geometric_tolerance &lt;- tolerance_zone.defining_tolerance[i] tolerance_zone &lt;= shape_aspect &lt;- shape_aspect_relationship.relatng_shape_aspect shape_aspect_relationship shape_aspect_relationship.related_shape_aspect-&gt; shape_aspect { shape_aspect.description = 'affected plane' } shape_definition = shape_aspect shape_definition characterized_definition = shape_definition characterized_definition &lt;- property_definition.definition.property_definition &lt;- property_definition.definition.property_definition property_definition_representation.definition property_definition_representation.used_representation -&gt; representation representation.items[i] -&gt; { representation_item.name = 'affected plane' } representation_item =&gt; geometric_representation_item =&gt; placement                     </pre>
symmetry_tolerance_to_datum_reference (as reference_datum)	PATH			<pre> symmetry_tolerance &lt;= geometric_tolerance_with_datum_reference geometric_tolerance_with_datum_reference.datum_system[i] -&gt; datum_reference                     </pre>
TARGET_AREA	datum_target	10303-47		

**Table 13 — Mapping table for geometric dimensioning and tolerancing UoF (continued)**

Application element	AIM element	Source	Rules	Reference path
TARGET_CIRCLE	placed_datum_target_feature	10303-238		placed_datum_target_feature <= datum_target <= shape_aspect { shape_aspect.description = 'circle' }
diameter	length_measure_with_unit	10303-41		placed_datum_target_feature <= datum_target <= shape_aspect shape_definition = shape_aspect shape_definition characterized_definition = shape_definition characterized_definition <= property_definition.definition property_definition represented_definition = property_definition represented_definition <= property_definition_representation.definition property_definition_representation => {property_definition_representation => shape_definition_representation} property_definition_representation property_definition_representation.used_representation -> {representation => shape_representation => shape_representation_with_parameters} representation representation.items[i] -> representation_item => { representation_item.name = 'target diameter' } measure_representation_item <= measure_with_unit => length_measure_with_unit
TARGET_POINT	placed_datum_target_feature	10303-238		placed_datum_target_feature <= datum_target <= shape_aspect { shape_aspect.description = 'point' }

**Table 13 — Mapping table for geometric dimensioning and tolerancing UoF (continued)**

Application element	AIM element	Source	Rules	Reference path
TARGET_RECTANGLE	placed_datum_target_feature	10303-238		<pre> placed_datum_target_feature &lt;=   datum_target &lt;=     shape_aspect   { shape_aspect.description = 'rectangle' } </pre>
target_length	length_measure_with_unit	10303-41		<pre> placed_datum_target_feature &lt;=   datum_target &lt;=     shape_aspect   shape_definition = shape_aspect   shape_definition characterized_definition = shape_definition characterized_definition &lt;-   property_definition.definition   property_definition represented_definition = property_definition represented_definition &lt;-   property_definition_representation.definition   {property_definition_representation =&gt;     shape_definition_representation}   property_definition_representation   property_definition_representation.used_representation -&gt;     {representation =&gt;       shape_representation =&gt;         shape_representation_with_parameters}       representation       representation.items[j] -&gt;         representation_item =&gt;           { representation_item.name = 'target length' }         measure_representation_item &lt;=           measure_with_unit =&gt;             length_measure_with_unit </pre>

**Table 13 — Mapping table for geometric dimensioning and tolerancing UoF (continued)**

Application element	AIM element	Source	Rules	Reference path
target_width	length_measure_with_unit	10303-41		<pre> placed_datum_target_feature &lt;= datum_target &lt;= shape_aspect shape_definition = shape_aspect shape_definition characterized_definition = shape_definition characterized_definition &lt;- property_definition.definition property_definition represented_definition = property_definition represented_definition &lt;- property_definition_representation.definition {property_definition_representation =&gt; shape_definition_representation} property_definition_representation property_definition_representation.used_representation -&gt; {representation =&gt; shape_representation =&gt; shape_representation_with_parameters} representation representation.items[i] -&gt; representation_item =&gt; { representation_item.name = 'target width' } measure_representation_item &lt;= measure_with_unit =&gt; length_measure_with_unit </pre>
TARGET_STRAIGHT_LINE	placed_datum_target_feature	10303-238		<pre> placed_datum_target_feature &lt;= datum_target &lt;= shape_aspect { shape_aspect.description = 'line' } </pre>



**Table 13 — Mapping table for geometric dimensioning and tolerancing UoF (continued)**

Application element	AIM element	Source	Rules	Reference path
target_length	length_measure_with_unit	10303-41		<pre> placed_datum_target_feature &lt;=   datum_target &lt;=     shape_aspect   shape_definition = shape_aspect   shape_definition characterized_definition = shape_definition   characterized_definition &lt;-     property_definition.definition   property_definition represented_definition = property_definition   represented_definition &lt;- property_definition_representation.definition   {property_definition_representation =&gt;   shape_definition_representation} property_definition_representation property_definition_representation.used_representation -&gt;   {representation =&gt;   shape_representation =&gt;   shape_representation_with_parameters}   representation   representation.items[i] -&gt;   representation_item =&gt;   { representation_item.name = 'target length' }   measure_representation_item &lt;=   measure_with_unit =&gt;   length_measure_with_unit </pre>
THICKNESS_SIZE_DIMENSION	#1: (dimensional_size) #2: (dimensional_size_with_path)	10303-47 10303-47		<pre> dimensional_size #2: { dimensional_size =&gt; dimensional_size_with_path } { dimensional_size.name = 'thickness size' } </pre>

**Table 13 — Mapping table for geometric dimensioning and tolerancing UoF (continued)**

Application element	AIM element	Source	Rules	Reference path
thickness_size_dimension to measurement_path (as used_path)	PATH			dimensional_size_with_path dimensional_size_with_path.path -> shape_aspect shape_definition = shape_definition characterized_definition = shape_definition characterized_definition <- property_definition.definition property_definition <- property_definition_representation.definition property_definition_representation property_definition_representation <- property_definition_representation.used_representation -> representation
TOLERANCE_CONDITION	#1: (modified_geometric_tolerance_modifier) #2: (referenced_modified_datum_modifier)	10303-47 10303-47		
#1: If the tolerance_condition is referenced by a geometric_tolerance. #2: If the tolerance_condition is referenced by a single_datum.				
condition	limit_condition	10303-47		#1: (modified_geometric_tolerance_modifier ->) #2: (referenced_modified_datum_modifier ->) limit_condition
TOLERANCE_ZONE	tolerance_zone	10303-47		
form_type	tolerance_zone_form.name	10303-47		tolerance_zone tolerance_zone.form -> tolerance_zone_form tolerance_zone_form.name
tolerance_zone to geometric_tolerance (as zone_for)	PATH			tolerance_zone tolerance_zone.defining_tolerance[i] -> geometric_tolerance
TOLERANCE_ZONE_DEFINITION	tolerance_zone_definition	10303-47		

Table 13 — Mapping table for geometric dimensioning and tolerancing UoF (continued)

Application element	AIM element	Source	Rules	Reference path
tolerance_zone_definition to tolerance_zone (as defining)	PATH			tolerance_zone_definition tolerance_zone_definition.zone -> tolerance_zone
first_element	shape_aspect	10303-41		tolerance_zone_definition tolerance_zone_definition.boundaries[i] -> shape_aspect
second_element	shape_aspect	10303-41		tolerance_zone_definition tolerance_zone_definition.boundaries[i] -> shape_aspect
TOTAL_RUNOUT_TOLERANCE	total_runout_tolerance	10303-519		total_runout_tolerance <= geometric_tolerance_with_datum_reference <= geometric_tolerance
angle	measure_with_unit	10303-41		total_runout_tolerance <= geometric_tolerance_with_datum_reference <= geometric_tolerance <- tolerance_zone.defining_tolerance[i] tolerance_zone <- tolerance_zone_definition.zone tolerance_zone_definition => runout_zone_definition runout_zone_definition.orientation -> runout_zone_orientation runout_zone_orientation.angle -> measure_with_unit
total_runout_tolerance to datum_reference (as reference_datum)	PATH			total_runout_tolerance <= geometric_tolerance_with_datum_reference geometric_tolerance_with_datum_reference.datum_system[i] -> datum_reference

**Table 13 — Mapping table for geometric dimensioning and tolerancing UoF (continued)**

Application element	AIM element	Source	Rules	Reference path
WIDTH_SIZE_DIMENSION	#1: (dimensional_size) #2: (dimensional_size_with_path)	10303-47 10303-47		dimensional_size #2: { dimensional_size => dimensional_size_with_path } { dimensional_size.name = 'width' }
width_size_dimension to measurement_path (as used_path)	PATH			dimensional_size_with_path dimensional_size_with_path_path -> shape_aspect shape_definition = shape_aspect characterized_definition = shape_definition characterized_definition <- property_definition.definition property_definition <- property_definition_representation.definition property_definition_representation property_definition_representation.used_representation -> representation

[Blank page]

**Table 14 — Mapping table for library reference UoF**

Application element	AIM element	Source	Rules	Reference path
BSU #1: if BSU is a Class_BSU #2: if BSU is a Property_BSU #3: if BSU is a Supplier_BSU	#1: (externally_defined_class) #2: (externally_defined_general_property) #3: (organization)	10303-238 10303-238 10303-41		#1: (externally_defined_class <= externally_defined_item)  #2: (externally_defined_general_property <= externally_defined_item)  #3: (organization)
code #1: if BSU is a Class_BSU #2: if BSU is a Property_BSU #3: if BSU is a Supplier_BSU	#1,2: (externally_defined_item.- item_id) #3: (organization.id)	10303-41 10303-41		#1: (externally_defined_class <= externally_defined_item externally_defined_item.item_id)  #2: (externally_defined_general_property <= externally_defined_item externally_defined_item.item_id)  #3: (organization.id)
CLASS_BSU	externally_defined_class	10303-238		[externally_defined_class <= class <= group] [externally_defined_class <= externally_defined_item {externally_defined_item.source -> external_source => known_source <= pre_defined_item pre_defined_item.name = 'ISO 13584 library'}]

Table 14 — Mapping table for library reference UoF (continued)

Application element	AIM element	Source	Rules	Reference path
class_bsu to supplier_bsu (as defined_by)	PATH			<pre> externally_defined_class &lt;= externally_defined_item externally_defined_item.source -&gt; external_source =&gt; known_source organization_item = known_source organization_item &lt;- applied_organization_assignment.items[i] applied_organization_assignment &lt;= organization_assignment {organization_assignment.role -&gt; organization_role organization_role.name = 'library supplier'} organization_assignment.assigned_organization -&gt; organization                     </pre>
version	identification_assignment.- assigned_id	10303-41		<pre> externally_defined_class external_identification_item = externally_defined_class external_identification_item &lt;- applied_external_identification_assignment.items[i] applied_external_identification_assignment &lt;= external_identification_assignment &lt;= identification_assignment {identification_assignment.role -&gt; identification_role identification_role.name = 'class version'} identification_assignment.assigned_id                     </pre>
EXTERNALLY_DEFINED_- REPRESENTATION	externally_defined_representation_- with_parameters	10303-238		<pre> externally_defined_representation_with_parameters &lt;= representation                     </pre>

**Table 14 — Mapping table for library reference UoF (continued)**

Application element	AIM element	Source	Rules	Reference path
externally_defined_representation_to_library_part_assignment (as identified_by)	PATH			externally_defined_representation_with_parameters classification_item = \ externally_defined_representation_with_parameters classification_item <- applied_classification_assignment.items[i] applied_classification_assignment
location	placement.location	10303-42		externally_defined_representation_with_parameters<= representation representation.items[i]-> representation_item=> geometric_representation_item=> placement placement.location
placement	placement	10303-42		externally_defined_representation_with_parameters<= representation representation.items[i]-> representation_item=> geometric_representation_item=> placement
<b>LIBRARY_PART_ASSIGNMENT</b>	applied_classification_assignment	10303-238		applied_classification_assignment <= classification_assignment
library part assignment to class_bsu (as definitional_class_bsu)	PATH			applied_classification_assignment <= classification_assignment {classification_assignment.role -> classification_role classification_role.name = 'definitional class membership'} classification_assignment.assigned_class -> group => {group.name = 'library identifier'} class => externally_defined_class



**Table 14 — Mapping table for library reference UoF (continued)**

Application element	AIM element	Source	Rules	Reference path
library_part_assignment to library_property_value (as definitional_property_value_pairs)	PATH			<pre>                     applied_classification_assignment &lt;=                     classification_assignment                     {classification_assignment.role -&gt;                     classification_role                     classification_role.name = 'definitional class membership'}                     classification_assignment.assigned_class -&gt;                     group =&gt;                     class =&gt;                     externally_defined_class &lt;=                     externally_defined_item &lt;-                     externally_defined_item_relationship.related_item                     externally_defined_item_relationship.name = 'name scope'}                     externally_defined_item_relationship.relation-&gt;                     externally_defined_item =&gt;                     externally_defined_general_property &lt;=                     general_property &lt;-                     general_property_association.base_definition                     general_property_association                     {general_property_association.name = 'definitional'}                     general_property_association.derived_definition-&gt;                     property_definition                     property_definition = represented_definition &lt;-                     represented_definition &lt;-                     property_definition_representation.definition                     property_definition_representation                     property_definition_representation.used_representation-&gt;                     representation                     {representation.name = 'property value'}                 </pre>
LIBRARY_PROPERTY_VALUE	representation	10303-43		<pre>                     representation                     {representation.name = 'property value'}                 </pre>

**Table 14 — Mapping table for library reference UoF (continued)**

Application element	AIM element	Source	Rules	Reference path
library_property_value to property_bsu (as value_property_bsu)	PATH			representation <- property_definition_representation.used_representation property_definition_representation property_definition_representation.definition -> represented_definition = general_property general_property => externally_defined_general_property

Table 14 — Mapping table for library reference UoF (continued)

Application element	AIM element	Source	Rules	Reference path
<p>value_amount</p> <p>#1: if boolean value</p> <p>#2: if integer value</p> <p>#3: if logical value</p> <p>#4: if number value</p> <p>#5: if real value</p> <p>#6: if string value</p>	<p>#1,#3,#6: (descriptive_ - representation_item)</p> <p>#2,#4,#5: (value_ - representation_item)</p>	<p>10303-45</p> <p>10303-43</p>		<pre> representation representation.items[i] -&gt; representation_item =&gt;  #1: (descriptive_representation_item {(descriptive_representation_item.description = 'TRUE') (descriptive_representation_item.description = 'FALSE')})  #2: (value_representation_item value_representation_item.value_component {value_representation_item.value_component-&gt; measure_value measure_value=count_measure})  #3: (descriptive_representation_item {(descriptive_representation_item.description = 'TRUE') (descriptive_representation_item.description = 'FALSE') (descriptive_representation_item.description = 'UNKNOWN')})  #4: (value_representation_item value_representation_item.value_component {value_representation_item.value_component-&gt; measure_value measure_value=count_measure})  #5: (value_representation_item value_representation_item.value_component {value_representation_item.value_component-&gt; measure_value measure_value=length_measure})  #6: (descriptive_representation_item descriptive_representation_item.description)                     </pre>

**Table 14 — Mapping table for library reference UoF (continued)**

Application element	AIM element	Source	Rules	Reference path
PROPERTY_BSU	externally_defined_general_property	10303-238		<pre>[externally_defined_general_property &lt;=   general_property] [externally_defined_general_property &lt;=   externally_defined_item   {externally_defined_item.source -&gt;     external_source =&gt;     known_source &lt;=     pre_defined_item     pre_defined_item.name = 'ISO 13584 library'}]}]</pre>
property_bsu to class_bsu (as name_scope)	PATH			<pre>externally_defined_general_property &lt;=   externally_defined_item &lt;-   externally_defined_item_relationship.relatng_item   externally_defined_item_relationship   {externally_defined_item_relationship.name = 'name scope'}   externally_defined_item_relationship.related_item -&gt;   externally_defined_item =&gt;   externally_defined_class</pre>
version	identification_assignment.- assigned_id	10303-41		<pre>externally_defined_general_property   external_identification_item = \   externally_defined_general_property   external_identification_item &lt;-   applied_external_identification_assignment.items[i]   applied_external_identification_assignment &lt;=   external_identification_assignment &lt;=   identification_assignment   {identification_assignment.role-&gt;   identification_role   identification_role.name = 'property_version'}   identification_assignment.assigned_id</pre>

**Table 14 — Mapping table for library reference UoF (continued)**

Application element	AIM element	Source	Rules	Reference path
SUPPLIER_BSU	organization	10303-41		<pre> externally_defined_class &lt;= externally_defined_item externally_defined_item.source -&gt; external_source =&gt; known_source organization_item = known_source organization_item &lt;- applied_organization_assignment.items[i] applied_organization_assignment &lt;= organization_assignment {organization_assignment.role -&gt; organization_role organization_role.name = 'library supplier'} organization_assignment organization_assignment.assigned_organization -&gt; organization                     </pre>

**Table 15 — Mapping table for management UoF**

Application element	AIM element	Source	Rules	Reference path
APPROVAL	approval	10303-41	1, 2	
actual_date	(date_and_time) (date)	10303-41 10303-41		approval <- approval_date_dated_approval approval_date_time {approval_date_time.role -> object_role object_role.name = 'actual'} approval_date_time.date_time -> date_time_select (date_time_select = date_and_time date_and_time) (date_time_select = date date)
planned_date	(date_and_time) (date)	10303-41 10303-41		approval <- approval_date_time.dated_approval approval_date_time {approval_date_time.role -> object_role object_role.name = 'planned'} approval_date_time.date_time -> date_time_select (date_time_select = date_and_time date_and_time) (date_time_select = date date)
purpose	approval.level	10303-41		
approval to approval_status (as status)	PATH			approval approval.status -> approval_status
APPROVAL_RELATIONSHIP	approval_relationship	10303-41		

**Table 15 — Mapping table for management UoF (continued)**

Application element	AIM element	Source	Rules	Reference path
description	approval_relationship.description	10303-41		
approval_relationship to approval (as related_approval)	PATH			approval_relationship approval_relationship.related_approval -> approval
approval_relationship to approval (as relating_approval)	PATH			approval_relationship approval_relationship.relatng_approval -> approval
relation_type	approval_relationship.name	10303-41		
APPROVAL_STATUS	approval_status	10303-41	4	
status_name	approval_status.name	10303-41		
APPROVING_PERSON_- ORGANIZATION	approval_person_organization	10303-41		
approval_date	date_and_time	10303-41		approval_person_organization date_and_time_item = approval_person_organization date_and_time_item <- applied_date_and_time_assignment.items[i] applied_date_and_time_assignment <= date_and_time_assignment {date_and_time_assignment.role -> date_time_role date_time_role.name = 'sign off'} date_and_time_assignment.assigned_date_and_time -> date_and_time
approving_person_organization to approval (as authorized_approval)	PATH			approval_person_organization approval_person_organization.authorized_approval -> approval

**Table 15 — Mapping table for management UoF (continued)**

Application element	AIM element	Source	Rules	Reference path
person_organization	(organization) (person_and_organization)	10303-41 10303-41		approval_person_organization approval_person_organization.person_organization -> person_organization_select (person_organization_select = organization organization) (person_organization_select = person_and_organization person_and_organization)
role	approval_role.role	10303-41		approval_person_organization approval_person_organization.role -> approval_role approval_role.role
ASSIGNED_DATE	applied_date_assignment	10303-238		
date_value	date	10303-41		applied_date_assignment <= date_assignment date_assignment.assigned_date -> date
role	date_role.name	10303-41		applied_date_assignment <= date_assignment date_assignment.role -> date_role date_role.name
ASSIGNED_ORGANIZATION	applied_organization_assignment	10303-238		
organization_value	organization	10303-41		applied_organization_assignment <= organization_assignment organization_assignment.assigned_organization -> organization



**Table 15 — Mapping table for management UoF (continued)**

Application element	AIM element	Source	Rules	Reference path
role	organization_role.name	10303-41		applied_organization_assignment <= organization_assignment organization_assignment.role -> organization_role organization_role.name
ASSIGNED_PERSON	applied_person_and_organization_- assignment	10303-238		
person_and_organization_value	person_and_organization	10303-41		applied_person_and_organization_assignment <= person_and_organization_assignment person_and_organization_assignment.assigned_person_- and_organization -> person_and_organization
role	person_and_organization_role.name	10303-41		applied_person_and_organization_assignment <= person_and_organization_assignment person_and_organization_assignment.role -> person_and_organization_role person_and_organization_role.name
ASSIGNED_TIME	applied_date_and_time_assignment	10303-238		
date_and_time_value	date_and_time	10303-41		applied_date_and_time_assignment <= date_and_time_assignment date_and_time_assignment.assigned_date_and_time -> date_and_time
role	date_time_role.name	10303-41		applied_date_and_time_assignment <= date_and_time_assignment date_and_time_assignment.role -> date_time_role date_time_role.name

**Table 15 — Mapping table for management UoF (continued)**

Application element	AIM element	Source	Rules	Reference path
LAST_MODIFIED_TIMESTAMP	applied_date_and_time_assignment	10303-238		<pre> applied_date_and_time_assignment &lt;= date_and_time_assignment.role -&gt; date_time_role { date_time_role.name = 'last modified' } </pre>
date_and_time_value	date_and_time	10303-41		<pre> applied_date_and_time_assignment &lt;= date_and_time_assignment date_and_time_assignment.assigned_date_and_time -&gt; date_and_time </pre>
last_modified_timestamp to executable, toolpath, operation, workpiece, or project (as items)	PATH			<pre> applied_date_and_time_assignment applied_date_and_time_assignment.items[i] -&gt; date_and_time_item ( date_and_time_item = machining_process_executable machining_process_executable ) ( date_and_time_item = machining_toolpath machining_toolpath ) ( date_and_time_item = machining_operation machining_operation ) ( date_and_time_item = product_definition product_definition ) ( date_and_time_item = product_definition_formation product_definition_formation ) { product_definition_formation.of_product -&gt; product =&gt; machining_project } ) </pre>
SECURITY_CLASSIFICATION	security_classification	10303-41		
classification_level	security_classification_level.name	10303-41		<pre> security_classification security_classification.security_level -&gt; security_classification_level security_classification_level.name </pre>
description	security_classification.purpose	10303-41		

**Table 15 — Mapping table for management UoF (continued)**

Application element	AIM element	Source	Rules	Reference path
SECURITY_CLASSIFICATION_ASSIGNMENT	applied_security_classification_assignment	10303-238		
security_classification_assignment to security_classification (as classification)	PATH			<pre> applied_security_classification_assignment &lt;= security_classification_assignment security_classification_assignment.assigned_security_classification -&gt; security_classification                     </pre>
security_classification_assignment to executable, toolpath, operation, workpiece, or project (as items)	PATH			<pre> applied_security_classification_assignment applied_security_classification_assignment.items[]-&gt; security_classification_item ( security_classification_item = machining_process_executable   machining_process_executable ) ( security_classification_item = machining_toolpath   machining_toolpath ) ( security_classification_item = machining_operation   machining_operation ) ( security_classification_item = product_definition   product_definition ) ( security_classification_item = product_definition_formation   product_definition_formation   { product_definition_formation.of_product -&gt;     product =&gt;     machining_project } )                     </pre>

The following rules are referenced in the preceding tables:

- 1) approval\_requires\_approval\_person\_organization
- 2) approval\_requires\_assignment
- 3) chamfer\_requires\_faces\_or\_features
- 4) dependent\_instantiable\_approval\_status
- 5) dependent\_instantiable\_derived\_unit
- 6) dependent\_instantiable\_named\_unit
- 7) edge\_round\_requires\_faces\_or\_features
- 8) feature\_optional\_machining\_property\_process
- 9) nc\_variable\_compatible\_initial\_value

The following notes are referenced in the preceding tables:

- 1) As part of the harmonization of GD&T definitions across AP 224, AP 214, and ISO 10303-1050, the mapping for plus/minus and limits and fits qualifications differ when they appear in a dimension tolerance versus other uses. As a result, these particular mappings are a bit convoluted. A complex instance of `measure_representation_item` and `qualified_representation_item` is normally used and the plus/minus, limits and fits, limit qualification, or significant digits are mapped as elements of the “qualifiers” attribute of `qualified_representation_item`. However, when a plus/minus or limits and fits qualifications appear in a dimension tolerance, they are mapped to the Part 47 `plus_minus_tolerance` type and a reference path links this to the `measure_representation_item`.
- 2) As part of the GD&T harmonization described in the note above, the mapping of value ranges differ when they appear in a dimension tolerance versus other uses. A range is normally mapped as a subtype of `compound_representation_item` containing `measure_representation_items` for the upper and lower bounds. However, in a dimension tolerance, the upper and lower bounds appear separately as items in a `shape_dimension_representation`.
- 3) AP 214 has both name and description for features while AP 224 only cares about a `usage_name` which maps to description. Here, `its_id` has a uniqueness constraint and seems semantically closer to name than description, so it is mapped to name.
- 4) The `its_operation` attribute is redundant. It combines the relationships established between `manufacturing_feature` and `machining/turning_workingstep` and the relationship between these workingstep types and `machining_operation`. The mapping path listed for this attribute simply concatenates the paths established for the other relationships.
- 5) AP 224 does not define a mapping for `explicit_representation`, but the usage observed in existing implementations corresponds to the alternate case given in this part of ISO 10303. This alternate is provided to allow the use of instance data that may have originated from an AP 224 process, but the preferred reference path should be used for any new instance data. See 5.2.1.2.2 for additional discussion on explicit feature geometry.
- 6) For bounding geometry that is either a block or cylinder, ISO 14649-10 references `block` and `right_circular_cylinder`. For harmonization with AP 224 and AP 214 these two cases have been mapped to the `shape_representation` subtypes `block_shape_representation` and `cylindrical_shape_representation` instead. Aside from these two cases, the mapping for `its_bounding_geometry` is simply the `its_geometry` parameter of the `its_rawpiece`.

7) The `product_definition_formation_with_specified_source` subtype of `product_definition_formation` is present in the integrated representation to simplify the use of workpiece descriptions that may have originated from an AP 203 process. This use of this subtype is not recommended in the general case.

8) Assembly information is likely to originate in upstream applications using AP 203 or AP 214, which permit assembly components to be placed using `mapped_item` or `item_defined_transformation`. The `originating_orientation` and `resulting_orientation` mappings allow either technique to be used for compatibility with existing APs and data sets. When using `item_defined_transformation`, some APs have not clearly stated which attribute refers to the component and which refers to the enclosing assembly, which has led to confusion. Here `transform_item_1` refers to the original workpiece placement and `transform_item_2` refers to the placement within the assembly. Additional discussion on the handling of shape in assemblies can be found in 5.2.1.6 of ISO 10303-214.

9) AP 224 defines special pocket subtypes for open and closed pockets with rectangular profiles. Within AP 224, pockets with rectangular profiles can be represented as a general pocket ARM object or as the rectangular specialization. Within this part of ISO 10303, no specialization exists, but the mappings have an alternate case to cover the AP 224 usage. This allows the use of pocket feature data that may have originated from an AP 224 process.

10) For harmonization with AP 224 and AP 214, the mapping path for `planar_radius` passes through the pocket bottom condition and should not be used for pockets with a `Through_pocket_bottom_condition`.

11) The pocket bottom condition has been mapped to a face surface representation rather than a region feature for harmonization with AP 224 and AP 214.

12) The preferred mapping table entry for Pocket and Round\_hole `bottom_at_path_end` matches the reference path given in the AP 224 specification and should be used for any new instance data. The alternate mapping table entry matches a non-conforming usage observed in existing AP 224 implementations and is provided to allow the use of instance data that may have originated from such a process.

13) The name of this attribute is confusing. This is the path along which the profile is swept, not a profile itself. The various ARM subtypes of `Profile_feature` specify the profiles that is swept. The usage of these attributes are described in 5.2.1.3.4.

14) The ARM attribute `parameter_index` maps to the same attribute of `representation_item` as the ARM attribute `parameter_name`. If the `parameter_index` is present, it shall be appended to the `representation_item.name` representing the `parameter_name`.

15) Although the `feature_placement` is represented as `axis2_placement3d` in both ISO 14649-10 and this part of ISO 10303, the numeric value of the placement will change due to the use of different reference points for measuring location in the ISO 14649 and ISO 10303 standards. See clause 5.2.1 for a complete description of the differences and instructions for converting between them.

16) Although the `initial_value` for `Nc_variable` is defined as a Number by ISO 14649, the mapping has been constructed as if it were actually of type `Nc_constant`, so as to avoid introducing a different way of handling essentially the same concept.

17) The `item_defined_transformation` locates the workpiece within a setup in a manner similar to an assembly. Here `transform_item_1` refers to the original workpiece placement and `transform_item_2`

refers to the placement within the setup. Previous APs have not clearly stated which side of the `item_defined_transform` refers to the enclosing assembly, which has led to confusion.

18) This ARM attribute is defined as a list. The mapping path shown in the table shows how to relate the elements of the list. Ordering is handled by the `sequence_position` attribute on the relationship, which is inherited from the `sequential_method` supertype. This attribute holds a number indicating the position within the list. For example, the fifth item in the list would have `sequence_position=5`.

19) The `Toolpath_list` application object is not mapped. Instead, the mapping goes directly to the tool-path objects. Ordering is handled by the `sequence_position` attribute on the relationship as described in NOTE 18.

20) The ARM models `Axis_trajectory` as two parallel lists, where `axis_list[1]` contains the axis name corresponding to the curve in `command[1]`. Then, `axis_list[2]` contains the axis name for `command[2]` and so on. In the AIM, parallel lists are not used. Instead, the `representation.items` set contains one bounded curve for each axis to be moved by the trajectory and the axis name is kept in the `representation_item.name` attribute of each curve.

21) The `process_model_list` application object is not mapped. Instead, the mapping goes directly to the process model objects. Ordering is handled by the `sequence_position` attribute on the relationship as described in NOTE 18.

22) The ARM attribute `corner_transitions` is defined as a list, but list ordering is not encoded by the mapping. If ordering is desired, the corner transitions shall be ordered by `corner_identity`.

23) If a manufacturing feature is used to establish a `Datum_defined_by_feature`, the `datum_feature` type must be added to the complex instance of `shape_aspect` subtypes used to represent the manufacturing features. A planar face manufacturing feature is normally mapped to a complex instance of `instanced_feature` and `flat_face`. If it is used as a datum, a complex instance of `instanced_feature`, `flat_face`, and `datum_feature` must be appear.

## 5.2 AIM EXPRESS short listing

This clause specifies the EXPRESS schema that uses elements from the integrated resources and the AICs and contains the types, entity specializations, rules, and functions that are specific to this part of ISO 10303. This clause also specifies modifications to the text for constructs that are imported from the integrated resources and the AICs. The definitions and EXPRESS provided in the integrated resources for constructs used in the AIM may include select list items and subtypes that are not imported into the AIM. Requirements stated in the integrated resources that refer to select list items and subtypes apply exclusively to those items that are imported into the AIM.

```

*)
SCHEMA integrated_cnc_schema;

USE FROM action_schema                                -- 10303-41
    (action,
     action_method,
     action_method_relationship,
     action_resource,
     action_resource_relationship,
     action_resource_type);

USE FROM aic_advanced_brep                            -- 10303-514
    (advanced_brep_shape_representation);

USE FROM aic_edge_based_wireframe                    -- 10303-501
    (edge_based_wireframe_shape_representation);

USE FROM aic_faceted_brep                            -- 10303-512
    (faceted_brep_shape_representation);

USE FROM aic_geometric_tolerances                    -- 10303-519
    (angularity_tolerance,
     circular_runout_tolerance,
     coaxiality_tolerance,
     common_datum,
     concentricity_tolerance,
     cylindricity_tolerance,
     flatness_tolerance,
     line_profile_tolerance,
     parallelism_tolerance,
     perpendicularity_tolerance,
     position_tolerance,
     roundness_tolerance,
     straightness_tolerance,
     surface_profile_tolerance,
     symmetry_tolerance,
     total_runout_tolerance);

USE FROM aic_geometrically_bounded_surface           -- 10303-507
    (geometrically_bounded_surface_shape_representation);

USE FROM aic_geometrically_bounded_wireframe        -- 10303-510

```

```
(geometrically_bounded_wireframe_shape_representation);
```

```
USE FROM aic_machining_feature                                -- 10303-522
(applied_area,
boss,
boss_top,
chamfer,
chamfer_offset,
circular_closed_profile,
circular_pattern,
closed_path_profile,
composite_hole,
compound_feature,
direction_shape_representation,
edge_round,
externally_defined_feature_definition,
face_shape_representation,
feature_component_definition,
feature_component_relationship,
feature_definition,
feature_pattern,
fillet,
flat_face,
gear,
hole_bottom,
instanced_feature,
linear_profile,
location_shape_representation,
marking,
modified_pattern,
ngon_closed_profile,
open_path_profile,
outer_round,
outside_profile,
partial_circular_profile,
path_feature_component,
path_shape_representation,
pattern_offset_membership,
pattern_omit_membership,
planar_shape_representation,
pocket,
pocket_bottom,
profile_floor,
protrusion,
rectangular_closed_profile,
rectangular_pattern,
removal_volume,
replicate_feature,
revolved_profile,
rib_top,
rib_top_floor,
round_hole,
rounded_end,
rounded_u_profile,
```



```

    shape_defining_relationship,
    shape_representation_with_parameters,
    slot,
    slot_end,
    spherical_cap,
    square_u_profile,
    step,
    taper,
    tee_profile,
    thread,
    thread_runout,
    transition_feature,
    turned_knurl,
    vee_profile);

USE FROM aic_manifold_surface -- 10303-509
    (manifold_surface_shape_representation);

USE FROM aic_non_manifold_surface -- 10303-508
    (non_manifold_surface_shape_representation);

USE FROM aic_shell_based_wireframe -- 10303-502
    (shell_based_wireframe_shape_representation);

USE FROM aic_topologically_bounded_surface -- 10303-511
    (advanced_face);

USE FROM application_context_schema -- 10303-41
    (application_context,
     application_context_element,
     application_protocol_definition,
     product_context,
     product_definition_context);

USE FROM approval_schema -- 10303-41
    (approval,
     approval_date_time,
     approval_person_organization,
     approval_relationship,
     approval_status);

USE FROM date_time_schema -- 10303-41
    (calendar_date,
     date,
     date_and_time,
     ordinal_date,
     week_of_year_and_day_date);

USE FROM document_schema -- 10303-41
    (document,
     document_usage_constraint,
     document_with_class);

USE FROM external_reference_schema -- 10303-41

```

ISO 10303-238:2007(E)

```
(externally_defined_item,  
externally_defined_item_relationship,  
pre_defined_item);
```

```
USE FROM geometric_model_schema -- 10303-42  
(block,  
right_circular_cylinder);
```

```
USE FROM geometry_schema -- 10303-42  
(bounded_curve,  
bounded_surface,  
elementary_surface,  
geometric_representation_context);
```

```
USE FROM group_schema -- 10303-41  
(group);
```

```
USE FROM iso13584_expressions_schema -- 13584-20  
(and_expression,  
binary_boolean_expression,  
boolean_expression,  
comparison_equal,  
comparison_expression,  
comparison_greater,  
comparison_greater_equal,  
comparison_less,  
comparison_less_equal,  
comparison_not_equal,  
expression,  
int_literal,  
int_numeric_variable,  
literal_number,  
multiple_arity_boolean_expression,  
not_expression,  
numeric_expression,  
numeric_variable,  
or_expression,  
real_literal,  
real_numeric_variable,  
simple_numeric_expression,  
unary_boolean_expression,  
xor_expression);
```

```
USE FROM iso13584_generic_expressions_schema -- 13584-20  
(binary_generic_expression,  
generic_expression);
```

```
USE FROM management_resources_schema -- 10303-41  
(approval_assignment,  
classification_assignment,  
classification_role,  
date_and_time_assignment,  
date_assignment,  
document_reference,
```

```

document_usage_constraint_assignment,
external_identification_assignment,
identification_assignment,
identification_role,
organization_assignment,
person_and_organization_assignment,
security_classification_assignment);

USE FROM material_property_definition_schema           -- 10303-45
(material_designation,
material_designation_characterization,
material_property);

USE FROM material_property_representation_schema       -- 10303-45
(material_property_representation);

USE FROM measure_schema                               -- 10303-41
(area_measure,
context_dependent_measure,
context_dependent_unit,
conversion_based_unit,
count_measure,
derived_unit,
descriptive_measure,
global_unit_assigned_context,
length_measure_with_unit,
length_unit,
mass_measure,
mass_measure_with_unit,
mass_unit,
measure_with_unit,
named_unit,
numeric_measure,
parameter_value,
plane_angle_measure_with_unit,
plane_angle_unit,
positive_plane_angle_measure,
ratio_measure,
ratio_measure_with_unit,
ratio_unit,
si_unit,
solid_angle_measure,
solid_angle_measure_with_unit,
solid_angle_unit,
time_measure,
time_measure_with_unit,
time_unit,
volume_measure);

USE FROM method_definition_schema                     -- 10303-49
(action_method_with_associated_documents,
concurrent_action_method,
sequential_method,
serial_action_method);

```

```
USE FROM person_organization_schema -- 10303-41
(organization,
 organization_role,
 organizational_address,
 person,
 person_and_organization,
 personal_address);

USE FROM process_property_representation_schema -- 10303-49
(action_property_representation,
 resource_property_representation);

USE FROM process_property_schema -- 10303-49
(action_property,
 action_resource_requirement,
 characterized_action_definition,
 characterized_resource_definition,
 process_product_association,
 process_property_association,
 property_process,
 requirement_for_action_resource,
 resource_property,
 resource_requirement_type);

USE FROM product_definition_schema -- 10303-41
(product,
 product_category,
 product_category_relationship,
 product_definition,
 product_definition_formation,
 product_definition_formation_with_specified_source,
 product_definition_relationship,
 product_definition_with_associated_documents,
 product_related_product_category);

USE FROM product_property_definition_schema -- 10303-41
(characterized_object,
 general_property,
 general_property_association,
 product_definition_shape,
 property_definition,
 shape_aspect,
 shape_aspect_relationship,
 shape_definition);

USE FROM product_property_representation_schema -- 10303-41
(context_dependent_shape_representation,
 property_definition_representation,
 shape_definition_representation,
 shape_representation,
 shape_representation_relationship);

USE FROM product_structure_schema -- 10303-44
```

```

(make_from_usage_option,
 next_assembly_usage_occurrence);

USE FROM qualified_measure_schema -- 10303-45
(descriptive_representation_item,
 expanded_uncertainty,
 measure_qualification,
 measure_representation_item,
 precision_qualifier,
 qualified_representation_item,
 qualitative_uncertainty,
 standard_uncertainty,
 uncertainty_qualifier,
 value_qualifier);

USE FROM representation_schema -- 10303-43
(compound_representation_item,
 global_uncertainty_assigned_context,
 item_defined_transformation,
 list_representation_item,
 mapped_item,
 representation,
 representation_item,
 representation_item_relationship,
 representation_relationship,
 representation_relationship_with_transformation,
 set_representation_item,
 value_representation_item);

USE FROM security_classification_schema -- 10303-41
(security_classification,
 security_classification_level);

USE FROM shape_aspect_definition_schema -- 10303-47
(apex,
 centre_of_symmetry,
 datum,
 datum_feature,
 datum_reference,
 datum_target,
 derived_shape_aspect,
 extension,
 geometric_alignment,
 geometric_intersection,
 parallel_offset,
 perpendicular_to,
 referenced_modified_datum,
 tangent);

USE FROM shape_dimension_schema -- 10303-47
(angular_location,
 angular_size,
 dimensional_characteristic_representation,
 dimensional_location,

```

```

        dimensional_location_with_path,
        dimensional_size,
        dimensional_size_with_path,
        shape_dimension_representation);

USE FROM shape_tolerance_schema                                -- 10303-47
    (limits_and_fits,
     modified_geometric_tolerance,
     plus_minus_tolerance,
     projected_zone_definition,
     runout_zone_definition,
     tolerance_value,
     tolerance_zone,
     tolerance_zone_definition,
     tolerance_zone_form);
(*

```

## 5.2.1 Fundamental concepts and assumptions

### 5.2.1.1 Introduction

The ISO 10303 application protocols describe various aspects of a product throughout the lifecycle from design to analysis to manufacturing and beyond. By mapping the information requirements to a common set of integrated resources these application protocols describe shared concepts in a consistent manner.

ISO 10303-238 is designed for representation and exchange of data for manufacture using numerically controlled machines. It begins with the information requirements set forth by the ISO 14649 data model for computerized numerical controllers and describes how to represent those within the larger view of product data defined by the combined set of ISO 10303 application protocols.

Where the ISO 14649 standards describe requirements not already handled by other APs, this integration process is straightforward. However, there are several areas where the ISO 14649 standards redefine concepts that have already been addressed by existing application protocols.

The first is the definition of manufacturing features. Requirements for manufacturing features are documented in AP 224 and AP 214, and the integrated resources used to describe them are documented in AIC 522. During development of the ISO 14649 standards, efforts were made to align ISO 14649 feature definitions with those already existing in ISO 10303. Progress was made, but a number of differences remain. See 5.2.1.2 for discussion of the general feature concepts and 5.2.1.3 for an explanation of how differences are handled for specific feature types within this part of ISO 10303.

The second is the use of units of measurement. The ISO 14649 standards constrain the usage of units to simplify their model. Within the context of ISO 10303 application protocols, this constraint is inappropriate because of the general unit handling mechanism of the ISO 10303 integrated resources. See 5.2.1.4 for discussion of measurement concepts in more detail.

In addition, there are several places where the ISO 14649 standards directly reference ISO 10303 integrated resources without giving any context as to how they should be used. To cover these situations, additional definitions have been added to Clause 4 to provide guidance. The ISO 10303 integrated rep-

resentation also requires additional context descriptions for some types of information. See 5.2.1.5 for discussion of these context descriptions.

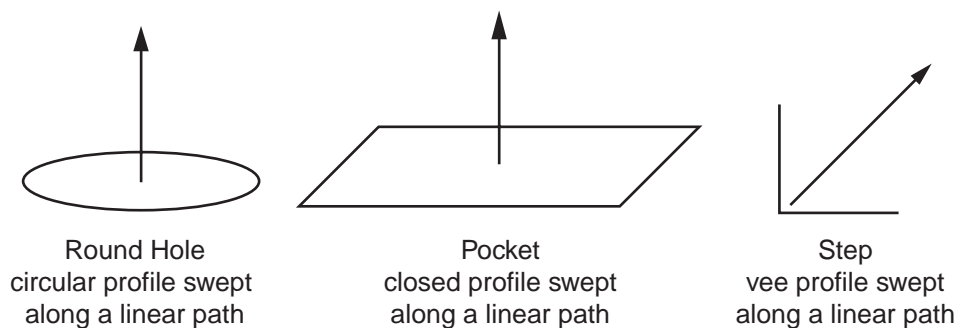
Finally, there are information requirements which were not considered by ISO 14649 for the isolated case of input to a CNC control, but which must be considered by this part of ISO 10303 for integrating across the lifecycle such as geometric dimensions and tolerances. Additional definitions have been added to Clause 4 to handle these.

## 5.2.1.2 Manufacturing feature concepts

### 5.2.1.2.1 Implicit shape by profile and travel path

In the ISO 10303 integrated representation, the shape of many manufacturing feature types can be described as a profile swept along a travel path. This implicit description of feature shape is controlled by characteristic parameters of the Profile (See 4.2.262) and Travel\_path (See 4.2.381) subtypes.

EXAMPLE 1 The profile and path representation of several feature types is shown in Figure 36. The shape of the features are controlled by such characteristic parameters as the length of the sweep path, the diameter of the swept circular profile, the length and width of the swept rectangular profile, etc.



**Figure 36 — Profile and path definition of features**

Most of the machining\_feature types defined by ISO 14649-10 use the same profile and path information requirements as the ISO 10303 integrated representation. However, in some, the authors of ISO 14649-10 chose to merge profile parameters into the feature definition, change orientations, or change conventions for reference points.

Several common cases are discussed below. See 5.2.1.3 for a systematic review of the profile and path conventions for feature types in the integrated representation, and an explanation of how to convert to the conventions used by ISO 14649.

EXAMPLE 2 The ISO 14649-10 definition of a round hole has a diameter measure. In the AIM mappings, we tie this to the diameter measure of a circular profile. The profile and path representation is still used at the AIM level for harmonization, even when the concepts are only tangentially represented in the ARM.

### 5.2.1.2.1.1 Feature placement and depth

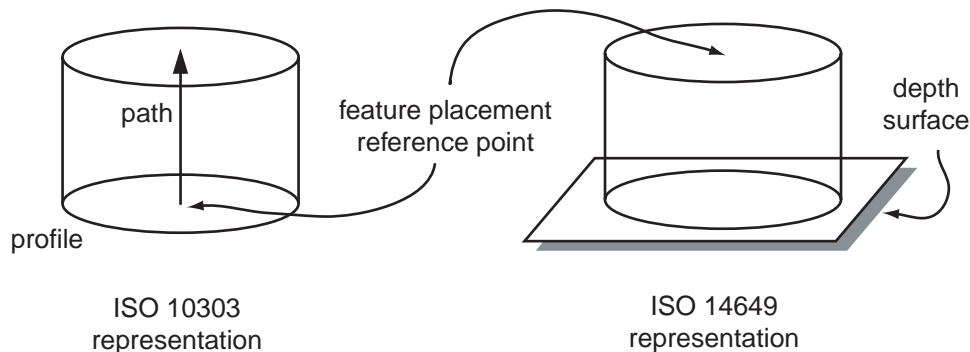
Each feature has a placement parameter that describes the location and orientation of the feature in space. The origin of the feature is the reference point for the placement. In the integrated representation, placement is conveyed as an instance of `axis2_placement3d`. A Cartesian point gives the location in space of the feature origin, and a pair of direction vectors gives the orientation of the Z and X axes of the feature.

To describe feature depth, the ISO 10303 integrated representation uses a parameter of the profile or path. This varies by feature type but is often the length of the sweep path. The origin of the feature is at the start of the sweep path, with the Z axis of the feature aligned along the path. This means that the feature origin is at the bottom of the feature with Z either pointed up and out of the material (pocket, round hole, outside profile), or along the material (slot, step, planar face).

The authors of ISO 14649 chose a different method and instead encode depth as a surface representing the deepest part of the feature. As part of this, ISO 14649 defines the origin of the feature at the top of the feature, so that depth can be computed geometrically as the distance between the feature placement and the depth surface.

Consequently, a feature may have different values for placement location, and possibly orientation, in the ISO 10303 integrated representation and the ISO 14649 representation.

**EXAMPLE** Consider Figure 37 and assume a round hole 2 units deep, with the bottom centre of the hole located at (0, 0, 0). In the ISO 10303 representation, the placement location of the hole is (0, 0, 0) and the length of the sweep path is 2 units. In the ISO 14649 representation, the placement location of the hole would be (0, 0, +2) and the feature would point to an instance of `elementary_surface` defining a plane at  $z=0$ ;



**Figure 37 — Feature placement differences**

ISO 14649 requires a depth surface for all `machining_feature` types, even where profile and path information is available. Within this part of ISO 10303, this constraint is relaxed since depth is already available from the profile and path parameters. The depth surface is represented by a parameter called "maximum feature depth," which is also an optional parameter in the AP 224 and AP 214 models.



**NOTE** Why were the reference points for features done this way? Before it is machined, the top of a feature often corresponds to a tangible location on the stock where a machinist could measure or make a mark. The bottom of the feature is usually buried within the stock.

The ISO 10303 standards originally defined features on the final form of the part as input to process planning. However, the features on the final part may not exactly match the features as machined. Consider a flat surface with a hole drilled in it. If the hole is drilled before the face is machined, the top of the hole will be higher than if it is drilled after the face is machined. The location in space of the bottom of the hole remains the same regardless of the sequence of operations.

Since planning activity may explore different operation sequences, describing the location from a reference point at the bottom of the feature allows the numeric value of the location to remain constant, even if the volume of the feature changes during process planning. Subsequent ISO 10303 standards continue to use this convention for compatibility.

ISO 14649 chose to use the top to more closely match the conventions used by machinists. Application software built around AP 238 may find it useful to present location information to a human using the ISO 14649 conventions, while still using the ISO 10303 convention for data exchange.

### 5.2.1.2.1.2 Orientation of profiles

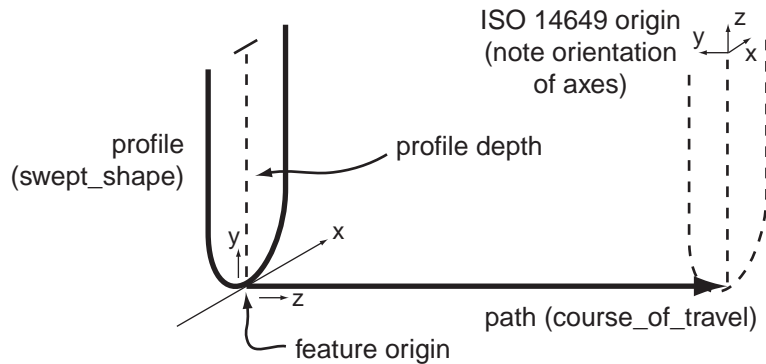
The placement of a feature is described by an `axis2_placement_3d`, which contains a pair of direction vectors that give the orientation of the Z and X axes of the feature. From these, the orientation of the Y axis is computed by vector cross product, and the orientation of the other feature aspects are determined by conventions established in the feature definitions.

In the ISO 10303 integrated representation, profiles are defined to exist in the XY plane. Most features sweep the profile in the Z direction (the one exception is planar face, which uses a linear profile defined to lie along the X axis and is swept along the Y axis). The origin of a feature, its profile, and its path are all at the same point in space. Within the AIM instance data, it is recommended that the "placement" parameters of all three share the same `axis2_placement_3d` instance.

In ISO 14649, profiles are also defined in the XY plane, but sometimes interpreted as lying in the XZ plane because of the way feature orientation is defined. In the ISO 14649 representation, the origin of the profile, path, and feature may lie at different points. See 5.2.1.3 for a listing of specific differences for each feature type.

**EXAMPLE** Figure 38 shows a slot made up of a rounded u profile. In the ISO 10303 representation, the feature placement gives the origin of both the sweep path and the profile, with the profile in the XY plane and the sweep along the Z axis.

In the ISO 14649 representation, the feature placement location defines the top centre of the slot, with the profile assumed to lie in the XZ plane, and swept along the Y axis. To find the origin of the profile, offset by the depth of the profile. Because of the change in axes, the direction of sweep is reversed, which means that the placement is also at the other end of the slot from the ISO 10303 representation.



**Figure 38 — Feature placement differences**

### 5.2.1.2.2 Explicit shape by geometry

In the ISO 10303 integrated representation, feature shape can be described implicitly using a collection of characteristic parameters like depth, width, etc. This is done using the profile and path representation discussed in previous sections. It is also possible to describe feature shape using an explicit representation based on faces from a boundary representation.

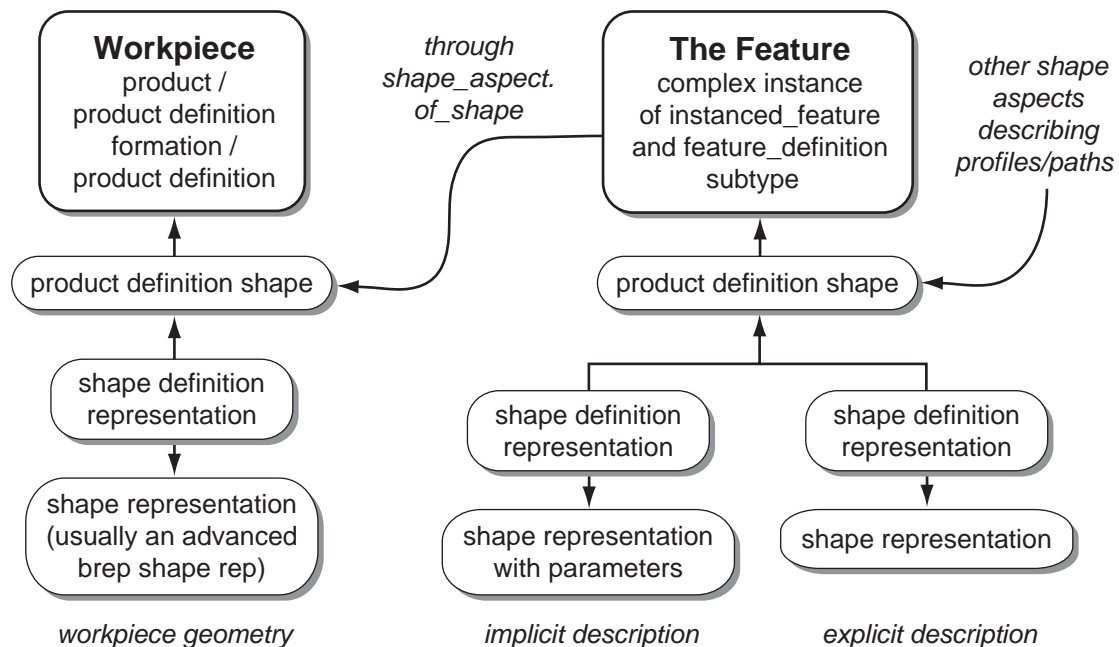
ISO 14649 only supports implicit representation of feature shape. For harmonization, an `explicit_representation` parameter has been added to `Manufacturing_feature` (See 4.2.198) support the explicit representation approach.

Within the AIM instance data, an explicit shape description appears as face instances in the items set of a `shape_representation`. The characteristic parameters for the implicit shape description appear as `measure_representation_item` instances in the items set of a `shape_representation_with_parameters`. The characteristic parameters for profile and path instances are handled in the same way.

Both of these representations are associated with the feature through `shape_definition_representation` instances which refer to a `property_definition`. The `property_definition` refers to the `shape_aspect` instances representing the feature. Features that inherit from `characterized_object` (all except for transition features) use the `product_definition_shape` subtype instead. Local rules permit only one `product_definition_shape` instance per feature, so the instance is shared by both implicit and explicit representations, as well as the reference paths for any profile and path instances.

**EXAMPLE 1** Figure 39 shows an instance diagram for a feature containing implicit and explicit representations. The instances describing the profile and path are not shown, but each is a `shape_aspect` subtype similar to the feature instance. The parameters describing each is held by a `shape_representation_with_parameters` instance and related to the profile or path using the same pattern of `shape_definition_representation` and `product_definition_shape` instances as shown below.

An alternate mapping path is given for the `explicit_representation` parameter that does not use the `shape_representation` or `shape_definition_representation` subtypes. This alternate should only be used for reading instance data that may have originated from an AP 224 process. The preferred mapping should be used for any new instance data. Examples 2 and 3 illustrate both mappings.



**Figure 39 — AIM Instances for implicit and explicit feature shape**

EXAMPLE 2 The preferred explicit\_representation encoding. In the exchange file fragment below, #10 describes a round hole feature on a workpiece (#100, not shown). The explicit shape description is given by the advanced\_face instances (#50, #60, #70) in a shape\_representation (#40) with a name of "explicit feature shape", and is related to the feature through a shape\_definition\_representation (#30) and product\_definition\_shape (#20).

```
#10=(
  CHARACTERIZED_OBJECT('', $)
  FEATURE_DEFINITION()
  INSTANCED_FEATURE()
  ROUND_HOLE()
  SHAPE_ASPECT('', $, #100, .T.)
);

#20=PRODUCT_DEFINITION_SHAPE('', '#10);
#30=SHAPE_DEFINITION_REPRESENTATION(#20, #40);
#40=SHAPE_REPRESENTATION('explicit feature shape', (#50, #60, #70), #200);
#50=ADVANCED_FACE( ... );
#60=ADVANCED_FACE( ... );
#70=ADVANCED_FACE( ... );

#100= [ ... to workpiece ... ]
#200= [ ... to geometric context ... ]
```

EXAMPLE 3 The alternate explicit\_representation encoding. The exchange file fragment below describes the same feature as the previous example, but the advanced\_face instances are in an instance of the representation base type (#40) with no name, and is related to the feature through a property\_definition\_representation (#30) and property\_definition (#20) with no name. Since other feature properties may have representations containing faces, there may be some ambiguity.

```

#10=(
  CHARACTERIZED_OBJECT('', $)
  FEATURE_DEFINITION()
  INSTANCED_FEATURE()
  ROUND_HOLE()
  SHAPE_ASPECT('', $, #100, .T.)
);

#20=PROPERTY_DEFINITION('', $, #10);
#30=PROPERTY_DEFINITION_REPRESENTATION(#20, #40);
#40=REPRESENTATION('', (#50, #60, #70), #200);
#50=ADVANCED_FACE( ... );
#60=ADVANCED_FACE( ... );
#70=ADVANCED_FACE( ... );

#100=PRODUCT_DEFINITION_SHAPE('', '#210);
#110=PRODUCT_DEFINITION( ... workpiece product definition ... );
#200= [ ... geometric context omitted ... ]

```

### 5.2.1.2.3 Features describing process or final form

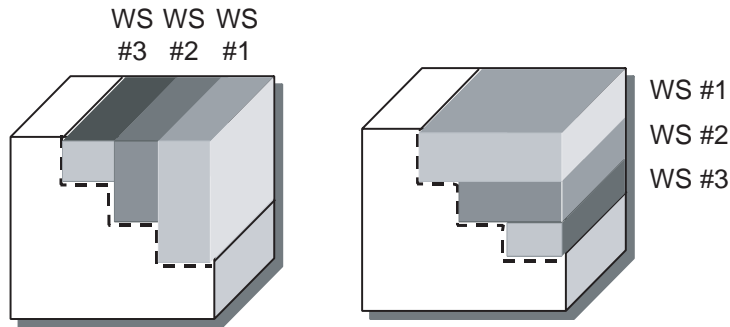
A machining workplan is composed of machining workingsteps, each of which refers to a feature that defines a volume of space acted upon by that workingstep. This volume of space is empty of material when the operation is finished, subject to any finishing allowance or overcut modifiers in the associated operation parameters. Furthermore, the workingstep shall not remove any material outside of the feature volume.

**NOTE** The volume defined by the feature may not be the exact removal volume since some of the material may have already been removed by previous workingsteps. Consider roughing and finishing of a pocket. Both workingsteps would refer to the pocket. The roughing step removes the entire volume except for a finishing allowance, while the finishing step removes only a thin shell.

These features are tightly tied to the machining process defined by the workplan. If a manufacturing engineer creates an alternate workplan to make the same workpiece, the new workplan may use a completely different set of features.

**EXAMPLE 1** Figure 40 shows a stairway-shaped workpiece and two different machining processes to produce that workpiece. The example on the right shows a depth-first machining workplan while the example on the left shows a breadth-first machining workplan. Both workplans produce the same result, but each calls out very different features.

AP 224 and other parts of ISO 10303 identify features on the final form of the workpiece that are not necessarily tied to a specific sequence of machining processes. These features are used as input to the process planning activity. The output of macro process-planning may be described as an AP 240 data set that will include these features but may identify additional intermediate features related to a particular process. This part of ISO 10303 describes the micro process-plan and is concerned with the features associated with a particular process, but it is desirable to link the features on the final form with the set of workingsteps that contribute to their manufacture. This associativity through the entire design to manufacturing path is useful for related downstream tasks, such as inspection, which could use the tracability to pinpoint critical areas of interest in the micro and macro process-plans.

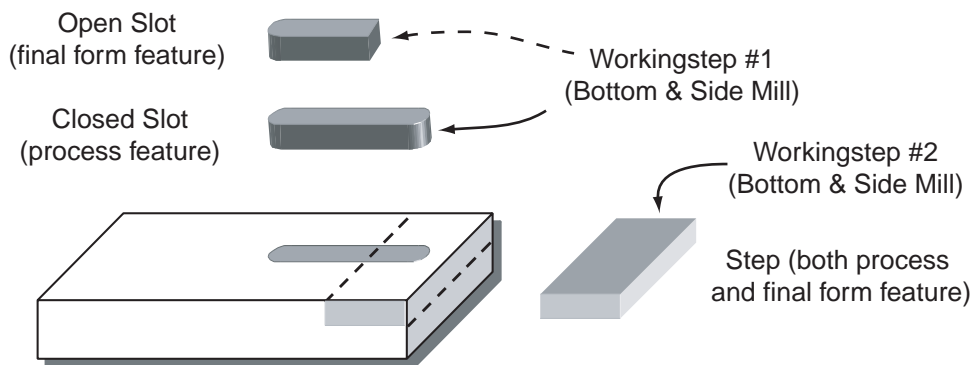


**Figure 40 — Alternate machining processes and features**

EXAMPLE 2 Figure 41 shows a workpiece whose final form contains a step and an open slot. The input to the process planner was an open slot and step, and for whatever reason, he decided to machine the slot first and the step second. The workplan contains two workingsteps, the first of which refers to a closed slot and the second of which refers to the step.

With the first workingstep, ISO 14649 is only concerned with the closed slot, and there is no way to trace back to the open slot feature on the final part. In the second workingstep, of course, the process and final form feature are the same thing.

A similar situation arises for "consumed" features such as entry holes, which are drilled to provide a starting point for an endmill to facilitate later machining operations. The entry hole feature never appears on the final workpiece because it is machined away by subsequent operations.



**Figure 41 — Example of process and final form features**

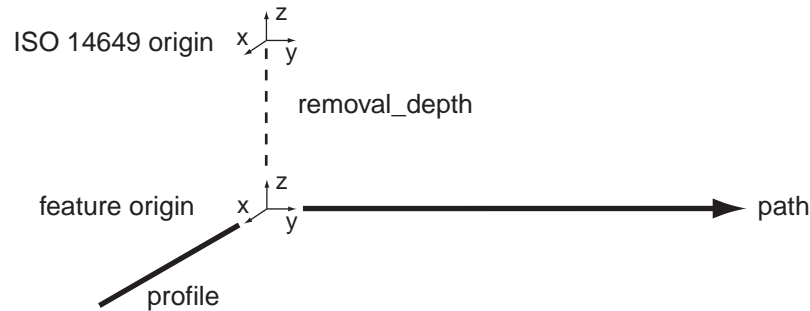
ISO 14649 links the machining\_workingstep application object to the feature that defines its removal volume through the its\_feature attribute. In this part of ISO 10303, an optional attribute called final\_features has been added to machining\_workingstep to support traceability back to the features used as input to the process planning activity.

If used, this attribute contains a set of one or more features visible on the final form of the workpiece that the process planner was targeting when he or she added the machining\_workingstep to the machining workplan.

### 5.2.1.3 Manufacturing feature details by type

#### 5.2.1.3.1 Planar face

In the ISO 10303 integrated representation, a planar face is represented by a linear profile swept along a linear path to form the plane that results after material has been removed. The origin of the feature lies on the plane. The depth of material removed is given by the `removal_depth` length parameter associated with the feature. Figure 42 illustrates the planar face parameters.



**Figure 42 — Planar face origin and parameters**

Two direction vectors are associated with the planar face. One is part of the linear path and defines the direction that the profile is swept along the path direction. This shall be aligned along the Y axis of the feature placement. The other direction vector is the `removal_direction`, which defines the surface normal of the plane. This shall be aligned with the Z axis of the feature placement. The profile is defined to extend along the X axis of the feature placement.

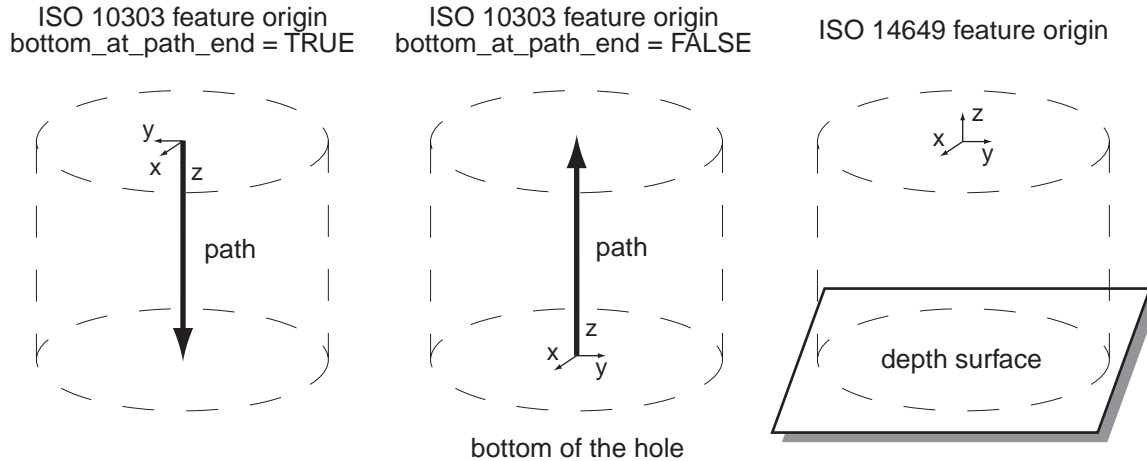
In ISO 14649, the placement of the feature is defined to lie at the top of the material to be removed. One must then geometrically evaluate the distance between this placement and the depth surface to determine the depth of material.

This part of ISO 10303 adds the `removal_depth` and `removal_direction` attributes to the `planar_face` application object. These attributes are present for harmonization with the other ISO 10303 parts and also simplify conversion between the two conventions.

To convert to the ISO 14649 representation, move the placement along the direction given by the `removal_direction` by the distance given by the `removal_depth` attribute.

#### 5.2.1.3.2 Round hole

In the ISO 10303 integrated representation, a round hole is represented by a circular closed profile swept along a linear path. The diameter of the profile is the diameter of the circle and the length of the travel path is the depth of the hole. The `Round_hole` (See 4.2.295) `bottom_at_path_end` parameter determines whether the placement is at the bottom of the hole with the Z axis pointing up out of the material or at the top of the hole with the Z axis pointing down into the material. Figure 43 illustrates the handling of round hole placement.



**Figure 43 — Round hole origin**

A direction vector is part of the linear path and defines the direction that the profile is swept. This shall be aligned along the Z axis of the feature placement. The profile lies in the XY plane of the feature placement with the feature placement at the centre of the profile.

In ISO 14649, a hole does not use profile or path definitions. Instead, the diameter is an attribute of the Round\_hole definition. To convey depth, the feature placement is assumed to be at the top of the hole with Z pointed away from the material. To determine the depth of the hole, one must geometrically evaluate the distance in the negative Z direction between this placement and the depth surface.

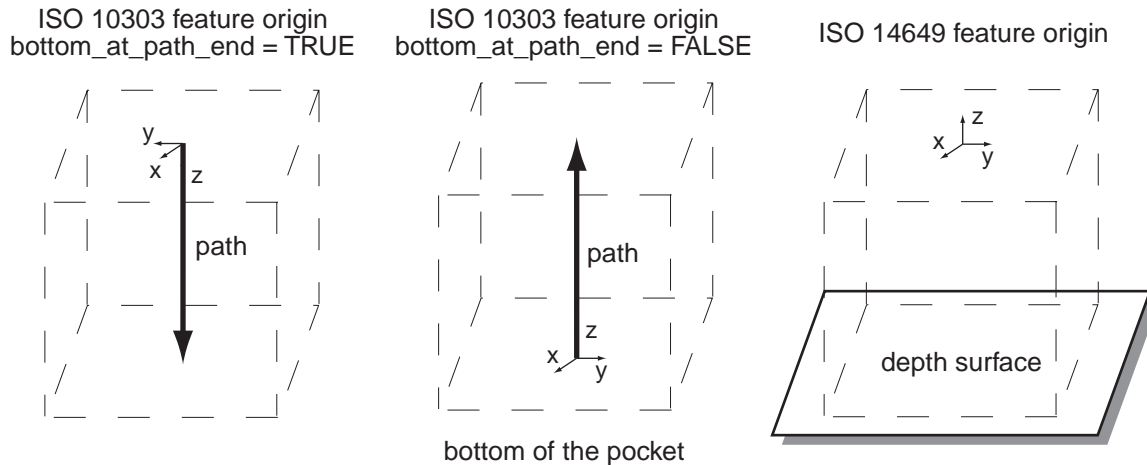
This part of ISO 10303 adds the course\_of\_travel attribute to the Round\_hole application object. This attribute represents the travel path for harmonization with the other ISO 10303 parts and simplifies conversion between the two conventions.

To convert to the ISO 14649 representation, construct the depth surface if it is not present and adjust the feature placement. For a placement is at the top of the hole (bottom\_at\_path\_end is TRUE), rotate the feature placement about the X axis so that  $Z \Rightarrow Y$  and  $Y \Rightarrow -Z$ . For a placement is at the bottom of the hole (bottom\_at\_path\_end is FALSE), move the placement in the Z direction by the length of the course\_of\_travel path.

### 5.2.1.3.3 Pocket

In the ISO 10303 integrated representation, a pocket is represented by a profile swept along a linear path. Material is removed on the inside of the profile, and the length of the travel path is the depth of the pocket. The Pocket (See 4.2.255) bottom\_at\_path\_end parameter determines whether the placement is at the bottom of the pocket with the Z axis pointing up out of the material or at the top of the pocket with the Z axis pointing down into the material. Figure 44 illustrates the handling of pocket placement.

A direction vector is part of the linear path and defines the direction that the profile is swept. This shall be aligned along the Z axis of the feature placement. The profile lies in the XY plane of the feature placement with the profile origin aligned with feature placement.



**Figure 44 — Pocket origin**

In ISO 14649, the pocket definitions have a profile but not a path attribute. In order to convey depth, the placement of the feature is assumed to be at the top of the feature with Z pointed away from the material. To determine the depth of the pocket, one must geometrically evaluate the distance in the negative Z direction between this placement and the depth surface.

This part of ISO 10303 adds the `course_of_travel` attribute to the Pocket application object. This attribute represents the travel path for harmonization with the other ISO 10303 parts and simplifies conversion between the two conventions.

To convert to the ISO 14649 representation, construct the depth surface if it is not present and adjust the feature placement. For a placement is at the top of the pocket (`bottom_at_path_end` is TRUE), rotate the feature placement about the X axis so that  $Z \Rightarrow Y$  and  $Y \Rightarrow -Z$ . For a placement is at the bottom of the pocket (`bottom_at_path_end` is FALSE), move the placement in the Z direction by the length of the `course_of_travel` path.

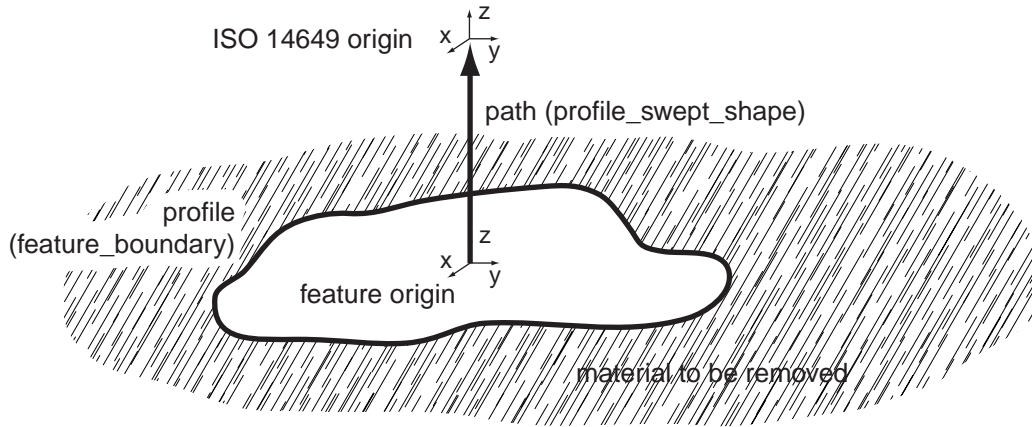
### 5.2.1.3.4 General outside and shape profile features

In the ISO 10303 integrated representation, a `Profile_feature` (`General_outside_profile` (See 4.2.145) or `Shape_profile` (See 4.2.306)) is represented by a profile swept along a linear path. Material is removed on the outside of the swept profile. The length of the travel path is the depth of the `profile_feature`.

For a general outside profile, the feature placement is at the bottom with the Z axis pointing up out of the material. Figure 45 illustrates the parameters associated with all `Profile_features` as well as the placement of a general outside profile.

Shape profiles have an additional floor condition that determines the feature placement. For shape profiles, the `Profile_floor` (`start_or_end` parameter) determines whether the feature placement is at the bottom of the profile with the Z axis pointing up out of the material (`start_or_end` is FALSE), or at the top of the profile with the Z axis pointing down into the material (`start_or_end` is TRUE). Figure 46 illustrates the placement of a shape profile.

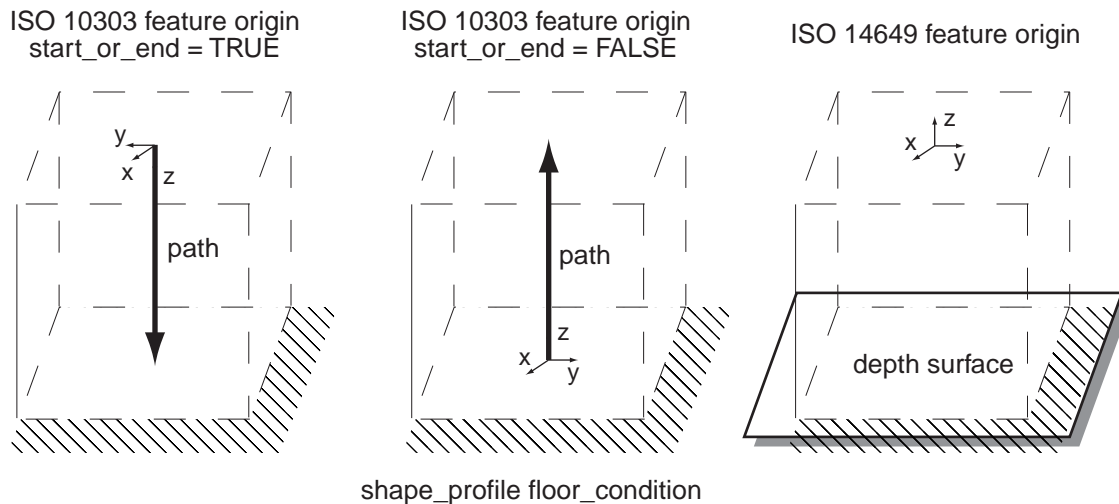




**Figure 45 — General Outside profile origin**

A direction vector is part of the linear path and defines the direction that the profile is swept. This shall be aligned along the Z axis of the feature placement. The swept profile lies in the XY plane of the feature placement with the origin of the swept profile aligned with feature placement.

In ISO 14649, the feature definitions have a profile and path, but use a different convention for placement. The placement of the feature is assumed to be at the top of the feature with Z pointed away from the material. To determine the depth of the Profile\_feature, one must geometrically evaluate the distance in the negative Z direction between this placement and the depth surface. However, the depth is also present in the length of the travel path, given by the profile\_swept\_shape attribute.



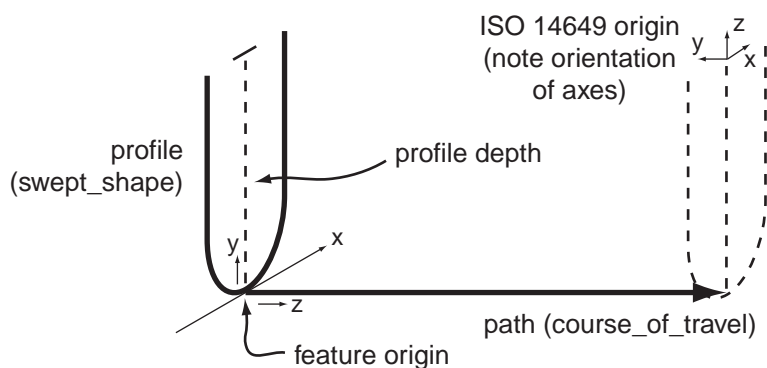
**Figure 46 — Shape profile origin**

To convert a General\_outside\_profile to the ISO 14649 representation, construct the depth surface if it is not present and move the placement in the Z direction by the length of the profile\_swept\_shape path.

To convert a Shape\_profile to the ISO 14649 representation, construct the depth surface if it is not present and adjust the feature placement. For a placement is at the top of the Shape\_profile (start\_or\_end is TRUE), rotate the feature placement about the X axis so that  $Z \Rightarrow Y$  and  $Y \Rightarrow -Z$ . For a placement is at the bottom of the Shape\_profile (start\_or\_end is FALSE), move the placement in the Z direction by the length of the profile\_swept\_shape path.

### 5.2.1.3.5 Slot

In the ISO 10303 integrated representation, a slot feature is represented by an open profile swept along a travel path. Material is removed on the inside of the swept profile. The depth of the open profile gives the depth of the slot feature. The feature placement is at the bottom of the feature with the Z axis pointing along the travel path. Figure 47 illustrates the slot parameters.



**Figure 47 — Slot origin and orientation**

A direction vector is part of the travel path and defines the direction that the profile is swept. This shall be aligned along the Z axis of the feature placement. The profile lies in the XY plane of the feature placement with the profile origin aligned with feature placement at the bottom of the slot feature.

In ISO 14649, the slot definition has a profile and path, but uses a different convention for the location and orientation of the feature placement. The placement is defined at the top of the material with the Z axis pointing up and the travel path is defined to extend along the Y axis. To determine the depth of the slot, one must geometrically evaluate the distance in the negative Z direction between this placement and the depth surface.

This part of ISO 10303 adds depth attributes to the Square\_u\_profile and Rounded\_u\_profile application objects. These attributes represent the depth of the profiles for harmonization with the other ISO 10303 parts and to simplify conversion between the two conventions. The depths of other open profile types can be computed from existing parameters.

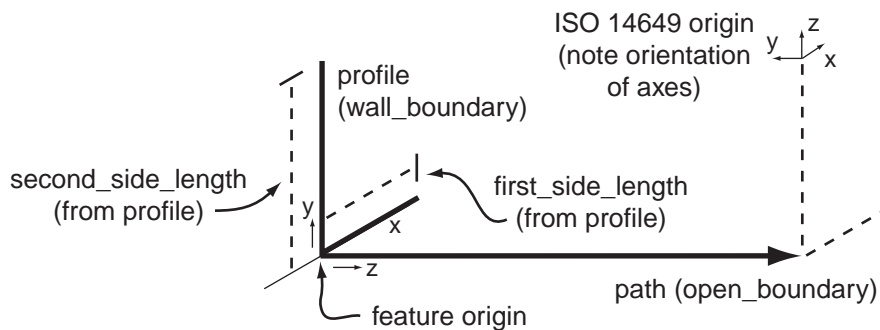
To convert to the ISO 14649 representation, rotate the feature placement about the X axis so that  $Z \Rightarrow Y$  and  $Y \Rightarrow -Z$ . Then move the placement along the length of the course\_of\_travel and depth of the swept profile.

Change the direction on the course\_of\_travel path so that it points along the new Y axis rather than the Z axis. The origin of the open profile is defined at the bottom of the profile, so it can no longer share

the placement of the feature. Assign it a separate placement offset by the profile depth. Finally, construct the depth surface if it is not present.

### 5.2.1.3.6 Step

In the ISO 10303 integrated representation, a step feature is represented by a vee profile swept along a linear path. Material is removed on the inside of the vee profile. The length of one arm of the vee profile gives the depth of the step feature. The length of the other arm gives the width of the step feature. The feature placement is at the point of the vee profile with the Z axis pointing along the travel path. Figure 48 illustrates the step parameters.



**Figure 48 — Step origin and orientation**

A direction vector is part of the travel path and defines the direction that the profile is swept. This shall be aligned along the Z axis of the feature placement. The profile lies in the XY plane of the feature placement with the profile origin aligned with feature placement at the point of the vee profile.

In ISO 14649, the step definition has a profile and path, but uses a different convention for the location and orientation of the feature placement. The placement is defined at the top of the material with the Z axis pointing up and the travel path is defined to extend along the Y axis. To determine the depth of the step, one must geometrically evaluate the distance in the negative Z direction between this placement and the depth surface.

This part of ISO 10303 adds the `first_side_length` and `second_side_length` attributes to the `Vee_profile` application object. These attributes represent the length of each arm of the vee for harmonization with the other ISO 10303 parts and to simplify conversion between the two conventions.

To convert to the ISO 14649 representation, rotate the feature placement about the X axis so that  $Z \Rightarrow Y$  and  $Y \Rightarrow -Z$ . Then move the placement along the length of the `course_of_travel` and the `second_side_length` arm of the vee profile.

Change the direction on the `course_of_travel` path so that it points along the new Y axis rather than the Z axis. The origin of the `vee_profile` is defined as the point of the vee, so it can no longer share the placement of the feature. Assign it a separate placement offset by the `second_side_length`. Finally, construct the depth surface if it is not present.

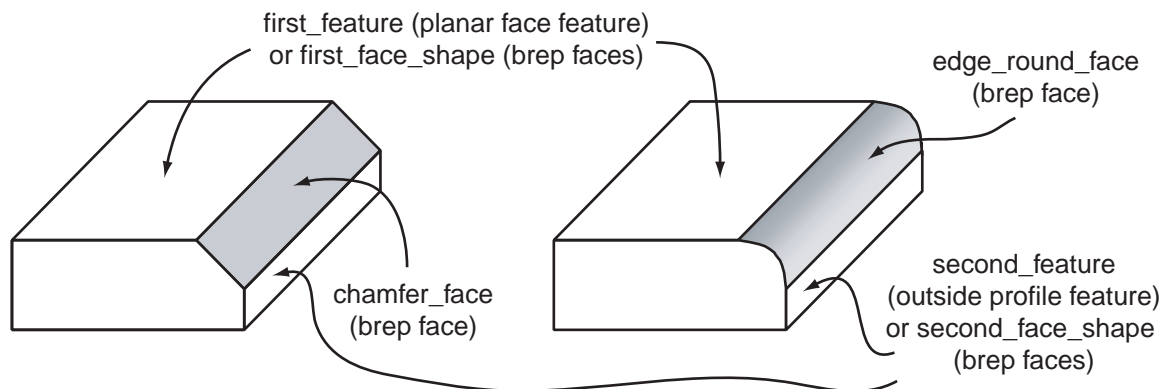
### 5.2.1.3.7 Transition Features

In the ISO 10303 application protocols, chamfers and edge rounds are defined as a relationship between two sets of geometric elements on the boundary representation of the workpiece. Each transition feature has a `first_face_shape` and a `second_face_shape` parameter. Each contains a set of `face_surface` or `oriented_face` instances taken from the `brep` description of the workpiece shape. In addition, several characteristic parameters are associated with each feature type. Chamfers have an offset and face angle, while edge rounds have two offsets and a radius to describe the transition surface.

ISO 14649 calls out the same characteristic parameters, but defines chamfers and edge rounds as a relationship between two features. Each transition feature has a `first_feature` and a `second_feature` parameter referring to the features on either side of the transition.

NOTE 1 Why were two approaches used? Historically, the ISO 10303 approach was defined first, but this requires that `brep` geometry be present in order to describe transition features. From the ISO 14649 perspective, geometry is optional and may be omitted, so it made sense to define transition features as a relationship between two features instead.

This part of ISO 10303 extends the `Chamfer` and `Edge_round` application objects to support the use of both approaches. This was done by adding `chamfer_face`, `first_face_shape` and `second_face_shape` attributes to `Chamfer` and adding `edge_round_face`, `first_face_shape` and `second_face_shape` attributes to `Edge_round`. These attributes are optional and represent the faces associated with the transition features for harmonization with the other ISO 10303 parts. Figure 49 shows both approaches for transition features.



**Figure 49 — Transition features relating faces or features**

The `chamfer_requires_faces_or_features` and `edge_round_requires_faces_or_features` rules have been added to require transition features to use at least one of the approaches.

NOTE 2 The AIC 522 rules originally required chamfers and edge rounds to have associated sets of faces. In order to accommodate either style, these rules were changed from required ("exactly one") to optional ("at most one") in AIC 522 Edition 2. APs that wish to permit only the face style can add a global rule to strengthen these constraints if desired.

As originally mapped in AP 224, `Edge_round` has three face sets, each mapped to a `face_shape_representation`. They are attached through the common `product_definition_shape` instance, but the mapping calls for the `edge_round_face` to be associated via a `shape_definition_representation` (and thus is also the feature's explicit representation) while the first and second `face_shapes` are called to be associated only by plain `property_definition_representation` instances.

## 5.2.1.4 Measurement concepts

### 5.2.1.4.1 Measurement values and units

In the ISO 10303 integrated representation, measurements such as length, angle, and time are represented as instances of the `measure_with_unit` type. A subtype is used when one exists for the particular type of measure value. The following sections discuss `measure_with_unit` subtypes in greater detail.

Within each instance, the `value_component` attribute holds the numeric value of a measure and the `unit_component` attribute holds a reference to an instance of `named_unit` or `derived_unit` defining the unit of measurement for the value. In this way, each numeric value is accompanied by a unit to provide context. In general, only one instance of each unit is needed, as a single unit instance may be shared by many `measure_with_unit` instances.

Measurements most often appear in the items set of the representation of an `action_property`, `resource_property`, or `property_definition`. The items set must refer to `representation_item` instances, so measurements are encoded as a `measure_representation_item`, which is a subtype of `measure_with_unit` and `representation_item`. The `measure_with_unit` subtypes for specific types of values are still used by creating a complex entity instance with `measure_representation_item`.

**EXAMPLE 1** No value-specific subtype of `measure_with_unit` exists for count measurements, so a count value is simply encoded as an instance of `measure_representation_item`. In the exchange file fragment below, #10 is an instance of this type describing a count of 5. The unit for the value is encoded by #20, which is a `context_dependent_unit` with a name of "count".

```
#10=MEASURE_REPRESENTATION_ITEM('', COUNT_MEASURE(5.),#20);
#20=CONTEXT_DEPENDENT_UNIT(#30,'count');
#30=DIMENSIONAL_EXPONENTS(0.,0.,0.,0.,0.,0.,0.);
```

**EXAMPLE 2** A length measurement would be encoded as a complex instance of `length_measure_with_unit` and `measure_representation_item`. In the exchange file fragment below, #10 is a complex instance of these types describing a value of 22.5mm. The millimetre unit is encoded by #20, which is also a complex instance of `length_unit` and `si_unit`. In general, each value-specific subtype of `measure_with_unit` has a corresponding subtypes of `named_unit` that is used in a complex instance with either `si_unit` or `conversion_based_unit` for units describing those types of values.

```
#40=(
  LENGTH_MEASURE_WITH_UNIT()
  MEASURE_REPRESENTATION_ITEM()
  MEASURE_WITH_UNIT(LENGTH_MEASURE(22.5),#50)
  REPRESENTATION_ITEM('')
);

#50=(
```

```

    LENGTH_UNIT ()
    NAMED_UNIT (*)
    SI_UNIT (.MILLI., .METRE.)
);

```

In ISO 14649 all basic measures are defined using specific, fixed units (all lengths are expressed in millimeters, all plane angles are expressed in degrees), so units do not appear explicitly in the data sets. ISO 14649 is unable to transmit measurements defined by other units without first numerically converting the values to the specified units.

To convert to the ISO 14649 representation, convert the numeric value of each measure from the unit description provided with the measure to the default unit specified by ISO 14649.

### 5.2.1.4.2 Tolerance qualifications

In the ISO 10303 integrated representation, qualifications such as plus/minus bounds, significant digits, limits and fits, or maximum/minimum may be applied to measurement values. This is encoded by creating a complex entity instance of `qualified_representation_item`, `measure_representation_item`, and, if one exists, a value-specific `measure_with_unit` subtype. The `qualified_representation_item` adds a set of value qualifiers to the instance that describe the conditions placed on the value.

**EXAMPLE 1** A length measurement with a plus/minus tolerance is encoded as a complex instance of `length_measure_with_unit`, `measure_representation_item`, and `qualified_representation_item`. In the exchange file fragment below, #10 describes a value of 80mm plus or minus 0.1, with 5 significant digits of precision. The upper and lower bounds (#20 and #30) are encoded using `standard_uncertainty` instances, while the digits of precision (#40) are encoded using a `precision_qualifier`.

```

#10= (
    LENGTH_MEASURE_WITH_UNIT ()
    MEASURE_REPRESENTATION_ITEM ()
    MEASURE_WITH_UNIT (LENGTH_MEASURE (80.), #50)
    QUALIFIED_REPRESENTATION_ITEM ((#20, #30, #40))
    REPRESENTATION_ITEM ('')
);
#20=STANDARD_UNCERTAINTY ('upper limit', '', 0.1);
#30=STANDARD_UNCERTAINTY ('lower limit', '', 0.1);
#40=PRECISION_QUALIFIER (5);

#50= (
    LENGTH_UNIT ()
    NAMED_UNIT (*)
    SI_UNIT (.MILLI., .METRE.)
);

```

**EXAMPLE 2** A length measurement with a value limitation is encoded in the same way, but a `type_qualifier` is used to indicate the type of limitation. In the exchange file fragment below, #10 describes a maximum value of 80mm.

```

#10= (
    LENGTH_MEASURE_WITH_UNIT ()
    MEASURE_REPRESENTATION_ITEM ()
    MEASURE_WITH_UNIT (LENGTH_MEASURE (80.), #30)
    QUALIFIED_REPRESENTATION_ITEM ((#20))
    REPRESENTATION_ITEM ('')
);

```

```

);
#20=TYPE_QUALIFIER('maximum');

#30=(
  LENGTH_UNIT()
  NAMED_UNIT(*)
  SI_UNIT(.MILLI.,.METRE.)
);

```

NOTE The qualified\_representation\_item encoding is used for all measure types, including lengths and plane angles, with one exception. When a length or plane angle measure is appears as the dimension\_value of a Geometric\_dimension (See 4.2.155), a plus/minus or limits and fits qualification is encoded differently for harmonization reasons. See the mapping specifications for Plus\_minus\_value and Limits\_and\_fits for details.

### 5.2.1.4.3 Angle (plane) measure

A plane angle measure is encoded using an instance of plane\_angle\_measure\_with\_unit. Local rules on this type require that the unit used to describe the measure be a plane\_angle\_unit, so a complex entity instance with si\_unit or a conversion\_based\_unit is used.

EXAMPLE A plane angle measurement used in a representation would be encoded as a complex instance of plane\_angle\_measure\_with\_unit and measure\_representation\_item. In the exchange file fragment below, #10 describes a value of 90 degrees.

```

#10=(
  MEASURE_REPRESENTATION_ITEM()
  MEASURE_WITH_UNIT(PLANE_ANGLE_MEASURE(90.),#30)
  PLANE_ANGLE_MEASURE_WITH_UNIT()
  REPRESENTATION_ITEM('')
);

```

The degree unit is encoded by #30, which is a complex instance of plane\_angle\_unit and conversion\_based\_unit that defines one degree as PI/180 radians. The name attribute has a value of "degree", which is not required, but is good form. The radian unit is encoded by #20, which is a complex instance of plane\_angle\_unit and si\_unit.

```

#20=(
  NAMED_UNIT(*)
  PLANE_ANGLE_UNIT()
  SI_UNIT($,.RADIAN.)
);

#30=(
  CONVERSION_BASED_UNIT('degree',#50)
  NAMED_UNIT(#40)
  PLANE_ANGLE_UNIT()
);
#40=DIMENSIONAL_EXPONENTS(0.,0.,0.,0.,0.,0.,0.);
#50=PLANE_ANGLE_MEASURE_WITH_UNIT(PLANE_ANGLE_MEASURE(0.01745329252),#20);

```

### 5.2.1.4.4 Angle (solid) measure

A solid angle measure is encoded using an instance of solid\_angle\_measure\_with\_unit. Local rules on this type require that the unit used to describe the measure be a solid\_angle\_unit, so a complex entity instance with si\_unit or a conversion\_based\_unit is used.

**EXAMPLE** A solid angle measurement used in a representation would be encoded as a complex instance of `solid_angle_measure_with_unit` and `measure_representation_item`. In the exchange file fragment below, #10 describes a value of 0.5 steradian.

```
#10= (
  MEASURE_REPRESENTATION_ITEM()
  MEASURE_WITH_UNIT(SOLID_ANGLE_MEASURE(0.5), #20)
  REPRESENTATION_ITEM('')
  SOLID_ANGLE_MEASURE_WITH_UNIT()
);
```

The steradian unit is encoded by #20, which is a complex instance of `solid_angle_unit` and `si_unit`. Conversion-based solid angle units, such as square degrees, are possible but not used in practice.

```
#20= (
  NAMED_UNIT(*)
  SI_UNIT($, .STERADIAN.)
  SOLID_ANGLE_UNIT()
);
```

### 5.2.1.4.5 Area measure

An area measure is encoded using an instance of `measure_with_unit` (or `measure_representation_item` when used in a representation). A `derived_unit` consisting of a length unit squared is used to describe the measure.

**NOTE** ISO 10303-41 defines value-specific subtypes `area_measure_with_unit` and `area_unit`, but the use of these are deprecated because they are not usable as defined. The unit for an area measure is described as a `derived_unit`, but a complex instance of `area_unit` and `derived_unit` is not permitted by the EXPRESS definition.

**EXAMPLE** An area measurement used in a representation would be encoded as a `measure_representation_item`. In the exchange file fragment below, #10 describes a value of 10 square millimetres.

```
#10=MEASURE_REPRESENTATION_ITEM('', AREA_MEASURE(10.), #20);
```

The square millimetre unit is encoded by #20, which is a `derived_unit` based on one `derived_unit_element` which references a millimetre unit (#50) with an exponent of 2. The `derived_unit` has an associated `name_attribute` instance with a value of "square millimetre", which is not required, but is good form.

```
#20=DERIVED_UNIT((#30));
#30=DERIVED_UNIT_ELEMENT(#50, 2.);
#40=NAME_ATTRIBUTE('square millimetre', #20);
#50= (
  LENGTH_UNIT()
  NAMED_UNIT(*)
  SI_UNIT(.MILLI., .METRE.)
);
```



### 5.2.1.4.6 Count measures

A count measure is encoded using an instance of `measure_with_unit` (or `measure_representation_item` when used in a representation). A `context_dependent_unit` with a name of "count" is used to describe the measure.

**EXAMPLE** A count measurement used in a representation would be encoded as a `measure_representation_item`. In the exchange file fragment below, #10 describes a count of 5. The count unit is encoded by #20.

```
#10=MEASURE_WITH_UNIT(COUNT_MEASURE(5.),#20);
#20=CONTEXT_DEPENDENT_UNIT(#30,'count');
#30=DIMENSIONAL_EXPONENTS(0.,0.,0.,0.,0.,0.,0.);
```

### 5.2.1.4.7 Force measure

A force measure is encoded using an instance of `measure_with_unit` (or `measure_representation_item` when used in a representation). The `value_component` of the instance is a `numeric_measure`. A `si_unit` or a `conversion_based_unit` is used to describe the measure.

**EXAMPLE** A force measurement used in a representation would be encoded as a `measure_representation_item`. In the exchange file fragment below, #10 describes a value of 20 Newtons (N) and #20 describes a value of 14 pounds force (lbf).

```
#10=MEASURE_REPRESENTATION_ITEM('',NUMERIC_MEASURE(20.),#30);
#20=MEASURE_REPRESENTATION_ITEM('',NUMERIC_MEASURE(14.),#40);
```

The Newton unit is encoded by #30, which is a simple entity instance of `si_unit`. The pound force unit is encoded as a simple entity instance of `conversion_based_unit` that defines one pound force equal to approximately 4.448221615 Newtons. The name attribute has a value of "pound-force", which is not required, but is good form. Note the dimensional exponents in #50 as pressure requires dimensions of (length \* mass)/time squared.

```
#30=SI_UNIT(*,$,.NEWTON.);
#40=CONVERSION_BASED_UNIT(#50,'pound-force',#60);
#50=DIMENSIONAL_EXPONENTS(1.,1.,-2.,0.,0.,0.,0.);
#60=MEASURE_WITH_UNIT(NUMERIC_MEASURE(4.448221615),#30);
```

### 5.2.1.4.8 Length measure

A length measure is encoded using an instance of `length_measure_with_unit`. Local rules on this type require that the unit used to describe the measure be a `length_unit`, so a complex entity instance with `si_unit` or a `conversion_based_unit` is used.

**EXAMPLE** A length measurement used in a representation would be encoded as a complex instance of `length_measure_with_unit` and `measure_representation_item`. In the exchange file fragment below, #10 describes a value of 12 inches.

```
#10=(
  LENGTH_MEASURE_WITH_UNIT()
  MEASURE_REPRESENTATION_ITEM()
  MEASURE_WITH_UNIT(TIME_MEASURE(12.),#30)
```

```

    REPRESENTATION_ITEM('')
);

```

The inch unit is encoded by #30, which is a complex instance of length\_unit and conversion\_based\_unit that defines one inch as 25.4 millimetres. The name attribute has a value of "inch", which is not required, but is good form. The millimetre unit is encoded by #20, which is a complex instance of length\_unit and si\_unit.

```

#20=(
    LENGTH_UNIT()
    NAMED_UNIT(*)
    SI_UNIT(.MILLI.,.METRE.)
);

#30=(
    CONVERSION_BASED_UNIT('inch',#50)
    LENGTH_UNIT()
    NAMED_UNIT(#40)
);
#40=DIMENSIONAL_EXPONENTS(1.,0.,0.,0.,0.,0.,0.);
#50=LENGTH_MEASURE_WITH_UNIT(LENGTH_MEASURE(25.4),#20);

```

### 5.2.1.4.9 Mass measure

A mass measure is encoded using an instance of mass\_measure\_with\_unit. Local rules on this type require that the unit used to describe the measure be a mass\_unit, so a complex entity instance with si\_unit or a conversion\_based\_unit is used.

**EXAMPLE** A mass measurement used in a representation would be encoded as a complex instance of mass\_measure\_with\_unit and measure\_representation\_item. In the exchange file fragment below, #10 describes a mass of 2 kilograms. The kilogram unit is encoded by #20, which is a complex instance of mass\_unit and si\_unit.

```

#10=(
    MASS_MEASURE_WITH_UNIT()
    MEASURE_REPRESENTATION_ITEM()
    MEASURE_WITH_UNIT(PLANE_ANGLE_MEASURE(2.),#20)
    REPRESENTATION_ITEM('')
);

#20=(
    MASS_UNIT()
    NAMED_UNIT(*)
    SI_UNIT(.KILO.,.GRAM.)
);

```

### 5.2.1.4.10 Power measure

A power measure is encoded using an instance of measure\_with\_unit (or measure\_representation\_item when used in a representation). The value\_component of the instance is a numeric\_measure. A si\_unit or a conversion\_based\_unit is used to describe the measure.

**EXAMPLE** A power measurement used in a representation would be encoded as a measure\_representation\_item. In the exchange file fragment below, #10 describes a value of 15 kilowatts (kW) and #20 describes a value of 14 horsepower (hp)

```
#10=MEASURE_REPRESENTATION_ITEM('',NUMERIC_MEASURE(15.),#30);
#20=MEASURE_REPRESENTATION_ITEM('',NUMERIC_MEASURE(14.),#40);
```

The kW unit is encoded by #30, which is a simple entity instance of si\_unit. The hp unit is encoded as a simple entity instance of conversion\_based\_unit that defines one horsepower equal to approximately 0.7456999 kilowatts. The name attribute has a value of "horsepower", which is not required, but is good form. Note the dimensional exponents in #50 as pressure requires dimensions of (length squared \* mass)/time cubed.

```
#30=SI_UNIT(*,.KILO.,.WATT.);
#40=CONVERSION_BASED_UNIT(#50,'horsepower',#60);
#50=DIMENSIONAL_EXPONENTS(2.,1.,-3.,0.,0.,0.);
#60=MEASURE_WITH_UNIT(NUMERIC_MEASURE(0.7456999),#30);
```

### 5.2.1.4.11 Pressure measure

A pressure measure is encoded using an instance of measure\_with\_unit (or measure\_representation\_item when used in a representation). The value\_component of the instance is a numeric\_measure. A si\_unit or a conversion\_based\_unit is used to describe the measure.

**EXAMPLE** A pressure measurement used in a representation would be encoded as a measure\_representation\_item. In the exchange file fragment below, #10 describes a value of 25 kilopascals (kPa) and #20 describes a value of 14 pounds per square inch (psi)

```
#10=MEASURE_REPRESENTATION_ITEM('',NUMERIC_MEASURE(25.),#30);
#20=MEASURE_REPRESENTATION_ITEM('',NUMERIC_MEASURE(14.),#40);
```

The kPa unit is encoded by #30, which is a simple entity instance of si\_unit. The psi unit is encoded as a simple entity instance of conversion\_based\_unit that defines one psi as 6.894757 kilopascals. The name attribute has a value of "pound/square inch", which is not required, but is good form. Note the dimensional exponents in #50 as pressure requires dimensions of mass/(length \* time squared).

```
#30=SI_UNIT(*,.KILO.,.PASCAL.);
#40=CONVERSION_BASED_UNIT(#50,'pound/square inch',#60);
#50=DIMENSIONAL_EXPONENTS(-1.,1.,-2.,0.,0.,0.);
#60=MEASURE_WITH_UNIT(NUMERIC_MEASURE(6.894757),#30);
```

### 5.2.1.4.12 Ratio and percentage measures

A ratio measure is encoded using an instance of ratio\_measure\_with\_unit. Local rules on this type require that the unit used to describe the measure be a ratio\_unit. Percentage measures are represented as an instance of ratio\_measure\_with\_unit with a numeric value of 0 representing 0/100 or 0% and a numeric value of 1 representing 100/100 or 100%.

**EXAMPLE** A ratio measurement used in a representation would be encoded as a complex instance of ratio\_measure\_with\_unit and measure\_representation\_item. In the exchange file fragment below, #10 describes a value of 25% (0.25). The ratio unit is encoded by #20.

```
#10=(
  MEASURE_REPRESENTATION_ITEM()
  MEASURE_WITH_UNIT(RATIO_MEASURE(0.25),#20)
  RATIO_MEASURE_WITH_UNIT()
```

```

    REPRESENTATION_ITEM('')
  );

  #20=RATIO_UNIT(#30);
  #30=DIMENSIONAL_EXPONENTS (0.,0.,0.,0.,0.,0.,0.);

```

### 5.2.1.4.13 Speed (linear) measure

A linear speed measure is encoded using an instance of `measure_with_unit` (or `measure_representation_item` when used in a representation). The `value_component` of the instance is a `numeric_measure`. A `derived_unit` consisting of a length unit per time unit is used to describe the measure.

**EXAMPLE** A linear speed measurement used in a representation would be encoded as a `measure_representation_item`. In the exchange file fragment below, #10 describes a value of 10 millimetres per second.

```
#10=MEASURE_REPRESENTATION_ITEM('', NUMERIC_MEASURE(10.), #20);
```

The mm/s unit is encoded by #20, which is a `derived_unit` based on a `derived_unit_element` which references a millimetre unit (#60) with an exponent of 1, and a `derived_unit_element` which references a second unit (#70) with an exponent of -1. The `derived_unit` has an associated `name_attribute` instance with a value of "millimetre/second", which is not required, but is good form.

To describe other velocity units, like meter per second or inch per minute, replace the length unit (#60) and the time unit (#70) with the appropriate meter, inch, or minute unit descriptions.

```

#20=DERIVED_UNIT((#30,#40));
#30=DERIVED_UNIT_ELEMENT(#60,1.);
#40=DERIVED_UNIT_ELEMENT(#70,-1.);
#50=NAME_ATTRIBUTE('millimetre/second',#20);

#60=(
  LENGTH_UNIT()
  NAMED_UNIT(*)
  SI_UNIT(.MILLI.,.METRE.)
);

#70=(
  NAMED_UNIT(*)
  SI_UNIT($,.SECOND.)
  TIME_UNIT()
);

```

### 5.2.1.4.14 Speed (linear, per tooth or revolution) measure

A linear speed that is described as a length per tool tooth, revolution, or other non-time quantity is encoded using an instance of `measure_with_unit` (or `measure_representation_item` when used in a representation). The `value_component` of the instance is a `numeric_measure`. A `derived_unit` consisting of a length unit per tooth, revolution, or other context-dependent unit is used to describe the measure.

**EXAMPLE** A length per tooth speed measure used in a representation would be encoded as a `measure_representation_item`. In the exchange file fragment below, #10 describes a value of 1 millimetre per tooth.

```
#10=MEASURE_REPRESENTATION_ITEM('', NUMERIC_MEASURE(1.), #20);
```

The mm/tooth unit is encoded by #20, which is a derived\_unit based on a derived\_unit\_element which references a millimetre unit (#60) with an exponent of 1, and a derived\_unit\_element which references a tooth context-dependent unit (#70) with an exponent of -1. The derived\_unit has an associated name\_attribute instance with a value of "millimetre/tooth", which is not required, but is good form.

To describe length per revolution units, like millimetre per revolution, replace the tooth context-dependent unit (#70) with a revolution context-dependent unit description. See 5.2.1.4.15 for an example of a revolution unit.

```
#20=DERIVED_UNIT((#30,#40));
#30=DERIVED_UNIT_ELEMENT(#60,1.);
#40=DERIVED_UNIT_ELEMENT(#70,-1.);
#50=NAME_ATTRIBUTE('millimetre/tooth',#20);

#60=(
  LENGTH_UNIT()
  NAMED_UNIT(*)
  SI_UNIT(.MILLI.,.METRE.)
);

#70=CONTEXT_DEPENDENT_UNIT(#80,'tooth');
#80=DIMENSIONAL_EXPONENTS(0.,0.,0.,0.,0.,0.,0.);
```

### 5.2.1.4.15 Speed (rotational) measure

A rotational speed measure is encoded using an instance of measure\_with\_unit (or measure\_representation\_item when used in a representation). The value\_component of the instance is a numeric\_measure. A derived\_unit consisting of a revolution context-dependent unit over a time unit is used to describe the measure.

**EXAMPLE** A rotational speed measurement used in a representation would be encoded as a measure\_representation\_item. In the exchange file fragment below, #10 describes a value of 5 revolutions per second.

```
#10=MEASURE_REPRESENTATION_ITEM('',NUMERIC_MEASURE(5.),#20);
```

The revolutions per second unit is encoded by #20, which is a derived\_unit based on a derived\_unit\_element which references a revolution unit (#60) with an exponent of 1 and a second unit (#80) with an exponent of -1. The derived\_unit has an associated name\_attribute instance with a value of "revolution/second", which is not required, but is good form.

To describe other rotational speed units, like revolutions per minute, replace the time unit (#80) with the appropriate minute unit description.

```
#20=DERIVED_UNIT((#30,#40));
#30=DERIVED_UNIT_ELEMENT(#60,1.);
#40=DERIVED_UNIT_ELEMENT(#80,-1.);
#50=NAME_ATTRIBUTE('revolution/second',#20);

#60=CONTEXT_DEPENDENT_UNIT(#70,'revolution');
#70=DIMENSIONAL_EXPONENTS(0.,0.,0.,0.,0.,0.,0.);

#80=(
  NAMED_UNIT(*)
  SI_UNIT($,.SECOND.)
```

```

    TIME_UNIT()
);

```

### 5.2.1.4.16 Time measure

A time measure is encoded using an instance of `time_measure_with_unit`. Local rules on this type require that the unit used to describe the measure be a `time_unit`, so a complex entity instance with `si_unit` or a `conversion_based_unit` is used.

**EXAMPLE** A time measurement used in a representation would be encoded as a complex instance of `time_measure_with_unit` and `measure_representation_item`. In the exchange file fragment below, #10 describes a value of 5 minutes.

```

#10=(
  MEASURE_REPRESENTATION_ITEM()
  MEASURE_WITH_UNIT(TIME_MEASURE(5.),#30)
  REPRESENTATION_ITEM('')
  TIME_MEASURE_WITH_UNIT()
);

```

The minute unit is encoded by #30, which is a complex instance of `time_unit` and `conversion_based_unit` that defines one minute as 60 seconds. The name attribute has a value of "minute", which is not required, but is good form. The second unit is encoded by #20, which is a complex instance of `time_unit` and `si_unit`.

```

#20=(
  NAMED_UNIT(*)
  SI_UNIT($,.SECOND.)
  TIME_UNIT()
);

#30=(
  CONVERSION_BASED_UNIT('minute',#50)
  NAMED_UNIT(#40)
  TIME_UNIT()
);
#40=DIMENSIONAL_EXPONENTS(0.,0.,1.,0.,0.,0.,0.);
#50=TIME_MEASURE_WITH_UNIT(TIME_MEASURE(60.),#20);

```

### 5.2.1.4.17 Torque measure

A torque measure is encoded using an instance of `measure_with_unit` (or `measure_representation_item` when used in a representation). The `value_component` of the instance is a `numeric_measure`. A `derived_unit` consisting of a length times a force unit is used to describe the measure.

**EXAMPLE 1** A torque measurement used in a representation would be encoded as a `measure_representation_item`. In the exchange file fragment below, #10 describes a value of 10 Newton meters.

```

#10=MEASURE_REPRESENTATION_ITEM('',NUMERIC_MEASURE(10.),#20);

```

The N-m unit is encoded by #20, which is a `derived_unit` based on a `derived_unit_element` which references a Newton unit (#60) with an exponent of 1, and a `derived_unit_element` which references a meter unit (#70) with an exponent of 1. The `derived_unit` has an associated `name_attribute` instance with a value of "newton meter", which is not required, but is good form.

```

#20=DERIVED_UNIT((#30,#40));
#30=DERIVED_UNIT_ELEMENT(#60,1.);
#40=DERIVED_UNIT_ELEMENT(#70,1.);
#50=NAME_ATTRIBUTE('newton meter',#20);

#60=SI_UNIT(*,$,.NEWTON.);
#70=(
  LENGTH_UNIT()
  NAMED_UNIT(*)
  SI_UNIT($,.METRE.)
);

```

**EXAMPLE 2** In the exchange file fragment below, #10 describes a value of 20 pound feet. To describe the pound foot torque unit, a derived\_unit is used as in the previous example. The force unit (#70) is given as a pound force unit description as in 5.2.1.4.7. The length unit (#110) is given as a foot unit.

```

#10=MEASURE_REPRESENTATION_ITEM('',NUMERIC_MEASURE(20.),#20);
#20=DERIVED_UNIT((#30,#40));
#30=DERIVED_UNIT_ELEMENT(#70,1.);
#40=DERIVED_UNIT_ELEMENT(#110,1.);
#50=NAME_ATTRIBUTE('pound foot',#20);

#60=SI_UNIT(*,$,.NEWTON.);
#70=CONVERSION_BASED_UNIT(#80,'pound-force',#90);
#80=DIMENSIONAL_EXPONENTS(1.,1.,-2.,0.,0.,0.,0.);
#90=MEASURE_WITH_UNIT(NUMERIC_MEASURE(4.448221615),#60);

#100=(
  LENGTH_UNIT()
  NAMED_UNIT(*)
  SI_UNIT(.MILLI.,.METRE.)
);
#110=(
  CONVERSION_BASED_UNIT('foot',#130)
  LENGTH_UNIT()
  NAMED_UNIT(#120)
);
#120=DIMENSIONAL_EXPONENTS(1.,0.,0.,0.,0.,0.,0.);
#130=LENGTH_MEASURE_WITH_UNIT(LENGTH_MEASURE(304.8),#100);

```

### 5.2.1.4.18 Volume measure

A volume measure is encoded using an instance of `measure_with_unit` (or `measure_representation_item` when used in a representation). A `derived_unit` consisting of a length unit cubed is used to describe the measure.

**NOTE** ISO 10303-41 defines value-specific subtypes `volume_measure_with_unit` and `volume_unit`, but the use of these are deprecated because they are not usable as defined. The unit for an volume measure is described as a `derived_unit`, but a complex instance of `volume_unit` and `derived_unit` is not permitted by the EXPRESS definition.

**EXAMPLE** A volume measurement used in a representation would be encoded as a `measure_representation_item`. In the exchange file fragment below, #10 describes a value of 20 cubic millimetres.

```

#10=MEASURE_REPRESENTATION_ITEM('',VOLUME_MEASURE(20.),#20);

```

The cubic millimetre unit is encoded by #20, which is a `derived_unit` based on a `derived_unit_element` which references a millimetre unit (#50) with an exponent of 3. The `derived_unit` has an associated `name_attribute` instance with a value of "cubic millimetre", which is not required, but is good form.

```
#20=DERIVED_UNIT((#30));
#30=DERIVED_UNIT_ELEMENT(#50,3.);
#40=NAME_ATTRIBUTE('cubic millimetre',#20);
#50=(
  LENGTH_UNIT()
  NAMED_UNIT(*)
  SI_UNIT(.MILLI.,.METRE.)
);
```

### 5.2.1.4.19 Feed, spindle, and dwell property representations

A number of properties on the technology and machining strategy application objects describe feedrate, spindle speed, or dwell time values. Several alternative types of measure value can be used to describe each of these values.

**EXAMPLE 1** A feedrate could be described either as a linear speed (length per unit of time), or as a length per tooth of the tool being used.

The ISO 14649 documents use different modeling styles to describe these alternatives. The ISO 14649-11 milling model frequently uses different attributes for each alternative with a local rule forbidding the use of more than one at a time. The ISO 14649-12 turning model frequently uses a `SELECT` type to model the alternatives.

**EXAMPLE 2** In ISO 14649-11, `Milling_technology` "spindle" and "cutspeed" are separate attributes that use different techniques (constant angular speed versus constant linear speed at the cutting point) to describe the machine tool spindle rotation. A local rule on `Milling_technology` prevents the use of both. ISO 14649-12 uses one attribute called "spindle\_speed" defined as a `Speed_select` `SELECT` type that models the same two different ways to describe spindle rotation.

In the integrated representation, all alternative description techniques for a particular kind of value (feed speed, spindle speed, or dwell time) are encoded using a single representation subtype.

These representation subtypes identifies the technique being used by with a particular value of the representation "description" attribute. Within the representation are representation items that give the numeric measure values. The uses and allowable combinations are described by the mapping specifications and local rules on the EXPRESS definition.

#### 5.2.1.4.19.1 Feed speeds

Feed speeds are encoded using `machining_feed_speed_representation` (See 5.2.3.1.45). This representation subtype handles four different ways of describing a feedrate:

- a linear speed (See 5.2.1.4.13), as used by the Technology "feedrate", and `Feed_velocity_type` application objects;



- a length per tooth of a tool (See 5.2.1.4.14), as used by the Milling\_technology "feedrate\_per\_tooth" application object;
- a length per spindle revolution (See 5.2.1.4.14), as used by the Turning\_technology "feedrate\_per\_revolution", and Feed\_per\_rev\_type application objects;
- a relative speed, expressed as a multiplier applied to a separate feed speed (See 5.2.1.4.12), as used by the Drilling\_type\_strategy "reduced\_feed\_at\_start" and "reduced\_feed\_at\_end", Drilling\_type\_operation "feed\_on\_retract", Turning\_machining\_strategy "variable\_feedrate", and Contour\_turning "variable\_stepover\_feed" application objects.

### 5.2.1.4.19.2 Spindle speeds

Spindle speeds are encoded using machining\_spindle\_speed\_representation (See 5.2.3.1.67). This representation subtype handles three different ways of describing a spindle speed:

- a rotational speed (See 5.2.1.4.15), as used by the Milling\_technology "spindle", and Const\_spindle\_speed application objects;
- a linear speed measured at the contact point between tool and surface (See 5.2.1.4.13), as used by the Milling\_technology "cutspeed", and Const\_cutting\_speed application objects;
- a relative speed, expressed as a multiplier applied to a separate spindle speed (See 5.2.1.4.12), as used by the Drilling\_type\_strategy "reduced\_cut\_at\_start" and "reduced\_feed\_at\_end" application object.

ISO 14649 defines the direction of spindle rotation to be counter-clockwise when described as a positive rotational speed value, and clockwise when described as a negative rotational speed value. However, ISO 14649-11 is silent on the direction of rotation when spindle speed is described as a linear speed value.

In this part of ISO 10303, the same sign convention shall be used for spindle speeds described as either rotational or linear speeds: positive linear speed describes counter-clockwise spindle rotation and negative linear speed describes clockwise spindle rotation. The rotational direction is as observed looking from spindle to workpiece. A zero rotational or linear speed shall indicate a stopped spindle.

NOTE Many cutting tools require clockwise motion so spindle speeds will typically be negative.

### 5.2.1.4.19.3 Dwell times

Dwell times are encoded using machining\_dwell\_time\_representation (See 5.2.3.1.40). This representation subtype handles two different ways of describing a dwell time:

- a time measure (See 5.2.1.4.16), as used by the Feedstop "dwell", Multistep\_drilling "dwell\_time\_step", Drilling\_type\_operation "dwell\_time\_bottom", and the Dwell\_time application objects;
- a count of spindle revolutions (See 5.2.1.4.6), as used by the Dwell\_revolution application object.

### 5.2.1.4.20 Boolean and symbolic property representations

A number of application object properties describe boolean or enumeration symbolic values. Each symbolic value is encoded using an instance of `descriptive_representation_item`. The description field of the instance holds the value.

Since the range of symbolic values is fixed, it is recommended to instantiate this entity exactly once for each unique symbolic value that appears in the data set. Properties that have the same symbolic value can share either the `descriptive_representation_item` or the enclosing representation.

**EXAMPLE** In the exchange file fragment below, #10 and #20 describe two `Milling_machine_functions` application objects, each with chip removal on and coolant on. Within the ARM, chip removal and coolant are both described as boolean parameters. In the integrated representation, these are represented as symbolic values 'chip removal on', 'chip removal off', 'coolant on', and 'coolant off'.

Only one `descriptive_representation_item` instance is needed to describe the 'chip removal on' value (#30), and it can be shared by all properties, along with its enclosing representation (#31). The instance describing 'coolant on' (#40) and its enclosing representation (#41) is shared as well.

```
#10=MACHINING_FUNCTIONS('functions one','milling','','');
#11=ACTION_PROPERTY('chip removal','','#10);
#12=ACTION_PROPERTY_REPRESENTATION('','',#11,#30);
#13=ACTION_PROPERTY('coolant','','#10);
#14=ACTION_PROPERTY_REPRESENTATION('','',#13,#40);

#20=MACHINING_FUNCTIONS('functions two','milling','','');
#21=ACTION_PROPERTY('chip removal','','#20);
#22=ACTION_PROPERTY_REPRESENTATION('','',#21,#30);
#23=ACTION_PROPERTY('coolant','','#20);
#24=ACTION_PROPERTY_REPRESENTATION('','',#23,#40);

#30=REPRESENTATION('constant',(#31),#50);
#31=DESCRIPTIVE_REPRESENTATION_ITEM('','chip removal on');

#40=REPRESENTATION('constant',(#41),#50);
#41=DESCRIPTIVE_REPRESENTATION_ITEM('','coolant on');
#50=REPRESENTATION_CONTEXT('','units not necessary');
```

### 5.2.1.5 Context concepts

#### 5.2.1.5.1 Representation contexts

Context forms an important part of the ISO 10303 integrated representation, particularly with respect to the description of geometric properties. The value of an `action_property`, `resource_property`, or `property_definition` is encoded as a set of `representation_items` within an instance of a representation. The `representation_context_of_items` attribute refers to a `representation_context` instance that supplies additional contextual information about the value.

Local rules on the ISO 10303 geometry definitions require that any enclosing representation must refer to a `geometric_representation_context` to identify the dimensionality (2D, 3D, etc.) of the geometry. The geometry definitions are unitless, so `global_unit_assigned_context` is also used to specify length, plane angle, and solid angle units. Finally, to enable solid model exchange between systems with dis-

similar geometric accuracy, `global_uncertainty_assigned_context` is often used to document an uncertainty distance below which two points are considered to be the same.

A representation can only refer to a single `representation_context` instance, so a complex entity instance of the types is normally used.

**EXAMPLE 1** In the exchange file fragment below, #10 is a representation containing an axis placement (#20, and #21) describing an origin location at (1.1, 2.2, 3.3). The representation context is given by #30 which indicates that the geometry described is three dimensional, lengths are measured in millimetres, angles in radians, solid angles in steradians, and points within 0.000006mm of each other are to be considered the same.

```
#10=SHAPE_REPRESENTATION('', (#20), #30);
#20=AXIS2_PLACEMENT_3D('orientation', #21, $, $);
#21=CARTESIAN_POINT('', (1.1, 2.2, 3.3));

#30=(
  GEOMETRIC_REPRESENTATION_CONTEXT(3)
  GLOBAL_UNCERTAINTY_ASSIGNED_CONTEXT((#40))
  GLOBAL_UNIT_ASSIGNED_CONTEXT((#50, #60, #70))
  REPRESENTATION_CONTEXT('ID1', '3D')
);

#40=UNCERTAINTY_MEASURE_WITH_UNIT(LENGTH_MEASURE(1.E-006), #50,
'DISTANCE_ACCURACY_VALUE',
'Maximum model space distance between geometric entities at asserted connectivities');

#50=( LENGTH_UNIT() NAMED_UNIT(*) SI_UNIT(.MILLI., .METRE.) );
#60=( NAMED_UNIT(*) PLANE_ANGLE_UNIT() SI_UNIT($, .RADIAN.) );
#70=( NAMED_UNIT(*) SI_UNIT($, .STERADIAN.) SOLID_ANGLE_UNIT() );
```

A context is still required for a representation containing non-geometric `representation_item` instances. In this case, an instance of the `representation_context` base type is sufficient.

In general, only one instance of each type of context is needed, as it may be shared by many representation instances.

**EXAMPLE 2** In the exchange file fragment below, #10 is a representation containing a description (#20) and a length measure (#21). The length measure is already completely described by its unit (#40) and neither it nor the description require additional context information. The representation context (#30) satisfies the EXPRESS definition requirement that the `representation_context_of_items` has a value.

```
#10=REPRESENTATION('', (#20, #21), #30);
#20=DESCRIPTIVE_REPRESENTATION_ITEM('', 'coolant on');
#21=(
  LENGTH_MEASURE_WITH_UNIT()
  MEASURE_REPRESENTATION_ITEM()
  MEASURE_WITH_UNIT(LENGTH_MEASURE(2.), #40)
  REPRESENTATION_ITEM('')
);

#30=REPRESENTATION_CONTEXT('', 'units not necessary');
#40=( LENGTH_UNIT() NAMED_UNIT(*) SI_UNIT(.MILLI., .METRE.) );
```

### 5.2.1.5.2 Product and product\_definition contexts

Within this part of ISO 10303, Project (See 4.2.269), Setup (See 4.2.304), and Workpiece (See 4.2.412) are encoded in the integrated representation as products. Like representations, additional context information is also required for these products.

A product is required to have a product\_context which identifies engineering discipline's point of view the data is being presented by the application protocol. This in turn refers to an application\_context and application\_protocol\_definition which describes the application protocol used to describe the product, the schema name, and status of the application protocol within the ISO standardization process. It is recommended to instantiate the product\_context, application\_context, and application\_protocol\_definition entities exactly once in the data set.

A product\_definition is required to have a product\_definition\_context which identifies the the life cycle stage or maturity of the data being presented and refers to an application context description. It is recommended to instantiate the product\_definition\_context entity exactly once in the data set.

NOTE A value of "manufacturing" is recommended for both product\_context discipline\_type and product\_definition\_context life\_cycle\_stage.

EXAMPLE In the exchange file fragment below, #10, #20, and #30 are the product structure instances encoding a workpiece with its\_id = "1234-K789" and a revision\_id = "1.0". The product\_context (#40) identified a design discipline, the product\_definition\_context (#70) identifies a life cycle stage, and instances #50 and #60 identify this part of ISO 10303.

```
#10=PRODUCT('1234-K789','widget','a fictional product',(#40));
#20=PRODUCT_DEFINITION_FORMATION('1.0','first version of our widget',#10);
#30=PRODUCT_DEFINITION('design','example product_definition',#20,#70);

#40=PRODUCT_CONTEXT('CNC Machining',#50,'manufacturing');
#50=APPLICATION_CONTEXT('Application protocol for the exchange of CNC data');
#60=APPLICATION_PROTOCOL_DEFINITION('international standard',
'integrated_cnc_schema',2006,#50);

#70=PRODUCT_DEFINITION_CONTEXT('CNC Machining',#50,'manufacturing');
```

### 5.2.1.6 Toolpath description concepts

#### 5.2.1.6.1 Matching curve parameterization

The definitions of Cutter\_contact\_trajectory (See 4.2.94), Cutter\_location\_trajectory (See 4.2.95), Axis\_trajectory (See 4.2.25), and Toolpath\_speed (See 4.2.374), require that the curves that describe location (basiccurve), tool axis, surface normal, and feed speed must have the same parameterization.

When the curves are b-splines, the intent of this requirement is that all curves are evaluated at the same U and V values to get the appropriate XYZ or IJK values. When the location curve is described using other types of bounded\_curve, such as a polyline, ISO 14649 does not describe how the corresponding tool axis, surface normal, and feed speed values are to be determined for specific location values.

NOTE Since these other types of curve have no explicit UV parameterization to synchronize, the simplest approach is to describe the tool axis, surface normal, or tool speed at the start and end of the curve, and then linearly interpolate between the two values as the tool moves along the basis curve. Polylines and composite curves are segmented, so the direction can be given at each segment.

Except for the cases described below, all supporting curves (tool axis, surface normal, or feed) shall be given as polyline with two points. The first point indicates the supporting value (tool axis, surface normal, or feed) at the start of the location curve, and the second point indicates the supporting value at the end of the location curve.

- given a location curve of type `b_spline_curve`, each supporting curve shall be either a `b_spline_curve` that evaluates to the appropriate supporting values (IJK or feed ratio) for a given UV pair, or as a polyline with a start and end point giving the appropriate supporting values;
- given a location curve of type `polyline`, each supporting curve shall be a polyline with the same number of points;
- given a location curve of type `composite_curve`, each supporting curve shall be a composite curve with the same number of curve segments. Each segment shall have a `parent_curve` of type as indicated herein for the `parent_curve` in the corresponding location curve segment;
- given a location curve of type `trimmed_curve`, `bounded_pcurve`, or `bounded_surface_curve`, each supporting curve shall be of type as indicated herein for the underlying location curve.

EXAMPLE The exchange file fragment below shows a sample `Cutter_location_trajectory` basiccurve (#10) and its `toolaxis` curve (#60). Both curves are polylines with the same number of points. At the locations described by #20 #30, and #40, the tool axis is as described by #70. At the location described by #50, the tool axis is as described by #80. The sharing of instance #70 is not required, but leads to a more space-efficient description than replicating the cartesian point values across three instances would.

```
#10=POLYLINE('basic curve for WS 12 TP 124',(#20,#30,#40,#50));
#20=CARTESIAN_POINT('',(2.9164976,0.4320305,-2.2));
#30=CARTESIAN_POINT('',(2.8524770,0.4960510,-3.2348622));
#40=CARTESIAN_POINT('',(-0.4960510,-2.8524770,-3.2348622));
#50=CARTESIAN_POINT('',(-0.4898882,-2.8586399,-3.1352428));

#60=POLYLINE('tool axis for WS 12 TP 124',(#70,#70,#70,#80));
#70=CARTESIAN_POINT('',(0.0616284,-0.0616284,0.9961947));
#80=CARTESIAN_POINT('',(-0.0616284,-0.0616284,0.9961947));
```

### 5.2.1.6.2 Toolpath direction vectors

The definitions of `Cutter_contact_trajectory` (See 4.2.94) and `Cutter_location_trajectory` (See 4.2.95) specify curves that describe the components of direction vectors for tool axis and surface normal. ISO 14649 does not indicate whether the direction vectors given by these curves shall be normalized (length equal to one).

It is recommended that these direction vectors be normalized.

### 5.2.1.6.3 Toolpath arcs

When describing a toolpath consisting of a circular arc, the `trimmed_curve` subtype of `bounded_curve` is used. The `trimmed_curve.basis_curve` attribute is an instance of `circle`, and the `trim_1` and `trim_2` attributes contain `cartesian_points` representing the start and end points respectively. The direction of traversal is indicated by comparing the `trimmed_curve.sense_agreement` attribute with the mathematical sense of the underlying circle.

**NOTE** Given a circle in the XY plane with an axis placement along the positive Z axis, a `sense_agreement` of true indicates counterclockwise motion (from 0,+X to +Y,0 to 0,-X to -Y,0), while a `sense_agreement` of false indicates clockwise motion.

**EXAMPLE** The exchange file fragment below shows a trimmed curve (#10), based on a circle located at (0,0,0) with a radius of 3.5. The arc starts (3.5,0,0) (#50) and traverses a 90 degree arc to (0,3.5,0) (#60).

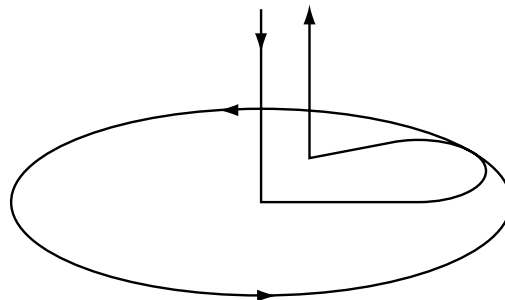
```
#10=TRIMMED_CURVE('', #20, (#50), (#60), .T., .CARTESIAN.);
#20=CIRCLE('', #30, 3.5);
#30=AXIS2_PLACEMENT_3D('centre placement', #40, $, $);
#40=CARTESIAN_POINT('centre location', (0., 0., 0.));
#50=CARTESIAN_POINT('start point', (3.5, 0., 0.));
#60=CARTESIAN_POINT('end point', (0., 3.5, 0.));
```

### 5.2.1.6.4 Complete circles

When describing a toolpath consisting of a complete circle, the `trimmed_curve` approach described in the previous section is used, but the `trim_1` (start) and `trim_2` (end) points shall be the same point in space, and specify where the cutter enters & exits the circle. The start and end may either reference the same `cartesian_point` instance or two instances with identical XYZ values.

**NOTE** Use of the same `cartesian_point` instance is preferred as this avoids numeric comparisons between coordinate values.

**EXAMPLE** Arcs and complete circles can occur when roughing out a circular pocket. An entry arc, full circle and then exit arc are illustrated in Figure 50.



**Figure 50 — Toolpath with complete circle**

## 5.2.2 Integrated CNC types

### 5.2.2.1 Integrated CNC type definitions

#### 5.2.2.1.1 approval\_item

An **approval\_item** identifies a **product**, **product\_definition**, **product\_definition\_formation**, or **security\_classification** to which an **approval** may be assigned.

EXPRESS specification:

```
*)
TYPE approval_item = SELECT (
    product,
    product_definition,
    product_definition_formation,
    security_classification
);
END_TYPE;
(*
```

#### 5.2.2.1.2 classification\_item

An **classification\_item** identifies a **externally\_defined\_representation\_with\_parameters** to which a **group** may be assigned.

EXPRESS specification:

```
*)
TYPE classification_item = SELECT (
    externally_defined_representation_with_parameters
);
END_TYPE;
(*
```

#### 5.2.2.1.3 date\_and\_time\_item

A **date\_and\_time\_item** identifies an **approval\_person\_organization**, **machining\_operation**, **machining\_process\_executable**, **machining\_toolpath**, **product**, **product\_definition**, **product\_definition\_formation**, or **security\_classification** to which a referenced **date\_and\_time** may be assigned.

EXPRESS specification:

```
*)
TYPE date_and_time_item = SELECT (
    approval_person_organization,
    machining_operation,
    machining_process_executable,
```

```

        machining_toolpath,
        product,
        product_definition,
        product_definition_formation,
        security_classification
    );
END_TYPE;
(*)

```

#### 5.2.2.1.4 date\_item

A **date\_item** identifies a **product**, **product\_definition**, or **product\_definition\_formation** to which a referenced **date** may be assigned.

EXPRESS specification:

```

*)
TYPE date_item = SELECT (
    product,
    product_definition,
    product_definition_formation
);
END_TYPE;
(*)

```

#### 5.2.2.1.5 document\_reference\_item

A **document\_reference\_item** identifies an **externally\_defined\_dimension\_definition**, **externally\_defined\_feature\_definition**, **material\_designation**, or **property\_definition** to which a referenced **document** may be assigned.

EXPRESS specification:

```

*)
TYPE document_reference_item = SELECT (
    externally_defined_dimension_definition,
    externally_defined_feature_definition,
    material_designation,
    property_definition
);
END_TYPE;
(*)

```

#### 5.2.2.1.6 external\_identification\_item

An **external\_identification\_item** identifies an **externally\_defined\_class** or **externally\_defined\_general\_property** to which an **identifier** and referenced **external\_source** may be assigned.



EXPRESS specification:

```

*)
TYPE external_identification_item = SELECT (
    externally_defined_class,
    externally_defined_general_property
);
END_TYPE;
(*

```

**5.2.2.1.7 identification\_item**

An **identification\_item** identifies a **dimensional\_size** to which an identifier may be assigned by means of an **applied\_identification\_assignment**.

EXPRESS specification:

```

*)
TYPE identification_item = SELECT (
    dimensional_size
);
END_TYPE;
(*

```

**5.2.2.1.8 organization\_item**

An **organization\_item** identifies a **product**, **product\_definition**, **product\_definition\_formation** or **known\_source** to which a referenced **organization** may be assigned.

EXPRESS specification:

```

*)
TYPE organization_item = SELECT (
    product,
    product_definition,
    product_definition_formation,
    known_source
);
END_TYPE;
(*

```

**5.2.2.1.9 person\_and\_organization\_item**

A **person\_and\_organization\_item** identifies a **product**, **product\_definition**, **product\_definition\_formation**, or **security\_classification** to which a referenced **person\_and\_organization** may be assigned.

EXPRESS specification:

```

*)

```

```
TYPE person_and_organization_item = SELECT (  
    product,  
    product_definition,  
    product_definition_formation,  
    security_classification  
);  
END_TYPE;  
(*
```

### 5.2.2.1.10 security\_classification\_item

A **security\_classification\_item** identifies a **machining\_operation**, **machining\_process\_executable**, **machining\_toolpath**, **product\_definition**, or **product\_definition\_formation** to which a referenced **security\_classification** may be assigned.

EXPRESS specification:

```
*)  
TYPE security_classification_item = SELECT (  
    machining_operation,  
    machining_process_executable,  
    machining_toolpath,  
    product_definition,  
    product_definition_formation  
);  
END_TYPE;  
(*
```

## 5.2.3 Integrated CNC entities

### 5.2.3.1 Integrated CNC entity definitions

#### 5.2.3.1.1 applied\_approval\_assignment

An **applied\_approval\_assignment** specifies those **approval\_item** instances to which a referenced **approval** is assigned.

EXPRESS specification:

```
*)  
ENTITY applied_approval_assignment  
    SUBTYPE OF (approval_assignment);  
    items : SET [1:?] OF approval_item;  
END_ENTITY;  
(*
```

Attribute definition:

**items**: the set of **approval\_item** instances to which a referenced **approval** is assigned.

### 5.2.3.1.2 applied\_classification\_assignment

An **applied\_classification\_assignment** specifies those **classification\_item** instances to which a referenced **group** is assigned.

EXPRESS specification:

```
*)
ENTITY applied_classification_assignment
  SUBTYPE OF (classification_assignment);
  items: SET[1:?] OF classification_item;
END_ENTITY;
(*
```

Attribute definition:

**items:** the set of **classification\_item** instances to which a referenced **group** is assigned.

### 5.2.3.1.3 applied\_date\_and\_time\_assignment

An **applied\_date\_and\_time\_assignment** specifies those **date\_and\_time\_item** instances to which a referenced **date\_and\_time** is assigned.

EXPRESS specification:

```
*)
ENTITY applied_date_and_time_assignment
  SUBTYPE OF (date_and_time_assignment);
  items : SET[1:?] OF date_and_time_item;
END_ENTITY;
(*
```

Attribute definition:

**items:** the set of **date\_and\_time\_item** instances to which a referenced **date\_and\_time** is assigned.

### 5.2.3.1.4 applied\_date\_assignment

An **applied\_date\_assignment** specifies those **date\_item** instances to which a referenced **date** is assigned.

EXPRESS specification:

```
*)
ENTITY applied_date_assignment
  SUBTYPE OF (date_assignment);
  items : SET[1:?] OF date_item;
END_ENTITY;
(*
```

Attribute definition:

**items:** the set of **date\_item** instances to which a referenced **date** is assigned.

### 5.2.3.1.5 applied\_document\_reference

An **applied\_document\_reference** specifies those **document\_reference\_item** instances to which a referenced **document** is assigned.

EXPRESS specification:

```
*)
ENTITY applied_document_reference
  SUBTYPE OF (document_reference);
  items : SET [1:?] OF document_reference_item;
END_ENTITY;
(*
```

Attribute definition:

**items:** the set of **document\_reference\_item** instances to which a referenced **document** is assigned.

### 5.2.3.1.6 applied\_document\_usage\_constraint\_assignment

An **applied\_document\_usage\_constraint\_assignment** specifies those **document\_reference\_item** instances to which a referenced **document** is assigned.

EXPRESS specification:

```
*)
ENTITY applied_document_usage_constraint_assignment
  SUBTYPE OF (document_usage_constraint_assignment);
  items : SET [1:?] OF document_reference_item;
END_ENTITY;
(*
```

Attribute definition:

**items:** the set of **document\_reference\_item** instances to which a referenced **document** is assigned.

### 5.2.3.1.7 applied\_external\_identification\_assignment

An **applied\_external\_identification\_assignment** specifies those **external\_identification\_item** instances to which an identifier and referenced **external\_source** is assigned.

EXPRESS specification:

```
*)
ENTITY applied_external_identification_assignment
  SUBTYPE OF (external_identification_assignment);
```

```

    items: SET[1:?] OF external_identification_item;
END_ENTITY;
(*)

```

Attribute definition:

**items:** the set of **external\_identification\_item** instances to which an identifier and referenced **external\_source** are assigned.

### 5.2.3.1.8 applied\_identification\_assignment

An **applied\_identification\_assignment** specifies those **identification\_item** instances to which the specified identifier is assigned.

EXPRESS specification:

```

*)
ENTITY applied_identification_assignment
  SUBTYPE OF (identification_assignment);
  items : SET [1:?] OF identification_item;
END_ENTITY;
(*)

```

Attribute definition:

**items:** the set of **identification\_item** instances to which a referenced identifier is assigned.

### 5.2.3.1.9 applied\_organization\_assignment

An **applied\_organization\_assignment** specifies those **organization\_item** instances to which a referenced **organization** is assigned.

EXPRESS specification:

```

*)
ENTITY applied_organization_assignment
  SUBTYPE OF (organization_assignment);
  items : SET [1:?] OF organization_item;
END_ENTITY;
(*)

```

Attribute definition:

**items:** the set of **organization\_item** instances to which a referenced **organization** is assigned.

### 5.2.3.1.10 applied\_person\_and\_organization\_assignment

An **applied\_person\_and\_organization\_assignment** specifies those **person\_and\_organization\_item** instances to which a referenced **person\_and\_organization** is assigned.

EXPRESS specification:

```
*)
ENTITY applied_person_and_organization_assignment
  SUBTYPE OF (person_and_organization_assignment);
  items : SET [1:?] OF person_and_organization_item;
END_ENTITY;
(*
```

Attribute definition:

**items:** the set of **person\_and\_organization\_item** instances to which a referenced **person\_and\_organization** is assigned.

### 5.2.3.1.11 applied\_security\_classification\_assignment

An **applied\_security\_classification\_assignment** specifies those **security\_classification\_item** instances to which a referenced **security\_classification** is assigned.

EXPRESS specification:

```
*)
ENTITY applied_security_classification_assignment
  SUBTYPE OF (security_classification_assignment);
  items : SET [1:?] OF security_classification_item;
END_ENTITY;
(*
```

Attribute definition:

**items:** the set of **security\_classification\_item** instances to which a referenced **security\_classification** is assigned.

### 5.2.3.1.12 back\_boring\_operation

A **back\_boring\_operation** is a type of **drilling\_type\_operation** that represents the details of a machining step in which a tool passes through an existing hole in the workpiece and enlarges the hole from the back of the workpiece. See the ARM definition for **Back\_boring\_operation** in ISO 14649-11 for more information.

EXPRESS specification:

```
*)
ENTITY back_boring_operation
  SUBTYPE OF (drilling_type_operation);
  WHERE
  WR1: (0 = SIZEOF (QUERY (amr <* get_relating_amr (SELF) |
    ('INTEGRATED_CNC_SCHEMA.MACHINING_FUNCTIONS_RELATIONSHIP'
      IN TYPEOF (amr)) AND NOT
    (verify_required_action_property
```

```

(amr.related_method, 'oriented spindle stop'))));
END_ENTITY;
(*

```

### Formal propositions:

**WR1:** All instances of **machining\_functions\_relationship** in which the **back\_boring\_operation** is the **relating\_method** shall have a **related\_method** which is the **definition** of exactly one **action\_property** with a **name** of 'oriented spindle stop'.

NOTE This corresponds to local constraint **WR1** on ARM entity Back\_boring in ISO 14649-11.

### 5.2.3.1.13 block\_shape\_representation

A **block\_shape\_representation** specifies the representation of a shape that is a rectangular volume defined as a rectangular area of a defined length. The enclosed area is defined by four straight sides with opposite sides equal in length.

NOTE This definition has been harmonized with the equivalent definition in ISO 10303-224.

### EXPRESS specification:

```

*)
ENTITY block_shape_representation
  SUBTYPE OF (shape_representation_with_parameters);
  WHERE
    wr1: (SIZEOF(SELF.items) = 4);
    wr2: (SIZEOF(QUERY ( it <* SELF.items |
      (('INTEGRATED_CNC_SCHEMA.PLACEMENT'
      IN TYPEOF(it)) AND (it.name = 'orientation')) )) = 1);
    wr3: (SIZEOF(QUERY ( it <* SELF.items |
      ((SIZEOF(
      ['INTEGRATED_CNC_SCHEMA.MEASURE_REPRESENTATION_ITEM',
      'INTEGRATED_CNC_SCHEMA.LENGTH_MEASURE_WITH_UNIT'] *
      TYPEOF(it)) = 2) AND (it.name = 'length')) )) = 1);
    wr4: (SIZEOF(QUERY ( it <* SELF.items |
      ((SIZEOF([
      'INTEGRATED_CNC_SCHEMA.MEASURE_REPRESENTATION_ITEM',
      'INTEGRATED_CNC_SCHEMA.LENGTH_MEASURE_WITH_UNIT'] *
      TYPEOF(it)) = 2) AND (it.name = 'width')) )) = 1);
    wr5: (SIZEOF(QUERY ( it <* SELF.items |
      ((SIZEOF([
      'INTEGRATED_CNC_SCHEMA.MEASURE_REPRESENTATION_ITEM',
      'INTEGRATED_CNC_SCHEMA.LENGTH_MEASURE_WITH_UNIT'] *
      TYPEOF(it)) = 2) AND (it.name = 'height')) )) = 1);
END_ENTITY; -- block_shape_representation
(*

```

Formal propositions:

**WR1:** The **block\_shape\_representation** shall contain exactly four **representation\_items** in its set of **items**.

**WR2:** One of the **representation\_items** used for the implicit representation of a **block\_shape\_representation** shall be of type **placement** with a **name** of 'orientation'.

**WR3:** One of the **representation\_items** used for the implicit representation of a **block\_shape\_representation** shall be of type **measure\_representation\_item** and **length\_measure\_with\_unit** with a **name** of 'length'.

**WR4:** One of the **representation\_items** used for the implicit representation of a **block\_shape\_representation** shall be of type **measure\_representation\_item** and **length\_measure\_with\_unit** with a **name** of 'width'.

**WR5:** One of the **representation\_items** used for the implicit representation of a **block\_shape\_representation** shall be of type **measure\_representation\_item** and **length\_measure\_with\_unit** with a **name** of 'height'.

Informal propositions:

**IP1:** The **block\_shape\_representation** shall be defined at the centre of the rectangular area in the X-Y plane with the width of the rectangle in the X direction, the height of the rectangle in the Y direction, and the length of the rectangle in the Z direction.

### 5.2.3.1.14 boring\_operation

A **boring\_operation** is a type of **drilling\_type\_operation** that represents the details of a drilling step in which in an existing hole is enlarged. See the ARM definitions for Boring\_operation, Boring, and Reaming in ISO 14649-11 for more information.

EXPRESS specification:

```
*)
ENTITY boring_operation
  SUBTYPE OF (drilling_type_operation);
  WHERE
  WR1: (SELF.description IN ['boring','reaming']);

  WR2: (verify_optional_action_property      (SELF, 'spindle stop')) AND
  (verify_enumeration_action_property      (SELF, 'spindle stop',
  ['spindle stop at bottom', 'spindle nonstop']));

  WR3: (verify_optional_action_property      (SELF, 'testcut depth')) AND
  (verify_length_measure_action_property    (SELF, 'testcut depth'));

  WR4: (verify_optional_action_property      (SELF, 'waiting position')) AND
  (verify_rep_item_for_action_property      (SELF, 'waiting position',
  ['INTEGRATED_CNC_SCHEMA.CARTESIAN_POINT']));
```



```
END_ENTITY;
(*
```

#### Formal propositions:

**WR1:** The **description** of the **boring\_operation** shall be either 'boring' or 'reaming'.

**WR2:** The **boring\_operation** shall be the **definition** of at most one **action\_property** with a **name** of 'spindle stop', and the **representation** used to describe the **action\_property** shall contain a **representation\_item** of type **descriptive\_representation\_item** with a **description** of either 'spindle stop at bottom' or 'spindle nonstop'.

**WR3:** The **boring\_operation** shall be the **definition** of at most one **action\_property** with a **name** of 'testcut depth', and the **representation** used to describe the **action\_property** shall contain a **representation\_item** of type **measure\_representation\_item** and **length\_measure\_with\_unit**.

**WR4:** The **boring\_operation** shall be the **definition** of at most one **action\_property** with a **name** of 'waiting position', and the **representation** used to describe the **action\_property** shall contain a **representation\_item** of type **cartesian\_point**.

### 5.2.3.1.15 bottom\_and\_side\_milling\_operation

A **bottom\_and\_side\_milling\_operation** is a **milling\_type\_operation** that represents a 2.5D milling step in which material is removed both parallel and perpendicular to the cutting tool axis. See the ARM definitions for **Bottom\_and\_side\_milling\_operation** and subtypes in ISO 14649-11 for more information.

#### EXPRESS specification:

```
*)
ENTITY bottom_and_side_milling_operation
  SUBTYPE OF (milling_type_operation);
  WHERE
    WR1: (SELF.description IN ['roughing','finishing']);

    WR2: (verify_optional_action_property (SELF, 'axial cutting depth')) AND
        (verify_length_measure_action_property (SELF, 'axial cutting depth'));

    WR3: (verify_optional_action_property (SELF, 'radial cutting depth')) AND
        (verify_length_measure_action_property (SELF, 'radial cutting depth'));

    WR4: (verify_optional_action_property (SELF, 'allowance side')) AND
        (verify_length_measure_action_property (SELF, 'allowance side'));

    WR5: (verify_optional_action_property (SELF, 'allowance bottom')) AND
        (verify_length_measure_action_property (SELF, 'allowance bottom'));

    WR6: NOT (SELF.description = 'roughing') OR
        ((verify_required_action_property (SELF, 'allowance side')) AND
         (verify_required_action_property (SELF, 'allowance bottom')));
```

END\_ENTITY;  
(\*

Formal propositions:

**WR1:** The **description** of the **bottom\_and\_side\_milling\_operation** shall be either 'roughing' or 'finishing'.

**WR2:** The **bottom\_and\_side\_milling\_operation** shall be the **definition** of at most one **action\_property** with a **name** of 'axial cutting depth', and the **representation** used to describe the **action\_property** shall contain a **representation\_item** of type **measure\_representation\_item** and **length\_measure\_with\_unit**.

**WR3:** The **bottom\_and\_side\_milling\_operation** shall be the **definition** of at most one **action\_property** with a **name** of 'radial cutting depth', and the **representation** used to describe the **action\_property** shall contain a **representation\_item** of type **measure\_representation\_item** and **length\_measure\_with\_unit**.

**WR4:** The **bottom\_and\_side\_milling\_operation** shall be the **definition** of at most one **action\_property** with a **name** of 'allowance side', and the **representation** used to describe the **action\_property** shall contain a **representation\_item** of type **measure\_representation\_item** and **length\_measure\_with\_unit**.

**WR5:** The **bottom\_and\_side\_milling\_operation** shall be the **definition** of at most one **action\_property** with a **name** of 'allowance bottom', and the **representation** used to describe the **action\_property** shall contain a **representation\_item** of type **measure\_representation\_item** and **length\_measure\_with\_unit**.

**WR6:** If the **description** of the **bottom\_and\_side\_milling\_operation** is 'roughing', the **bottom\_and\_side\_milling\_operation** shall be the **definition** of exactly one **action\_property** with a **name** of 'allowance side' and exactly one **action\_property** with a **name** of 'allowance bottom'.

NOTE This corresponds to local constraints **WR1** and **WR2** on the ARM entity **Bottom\_and\_side\_rough\_milling** in ISO 14649-11.

### 5.2.3.1.16 class

A **class** is a type of **group** that specifies a type of classification assignment.

NOTE This definition has been harmonized with the equivalent definition in ISO 10303-214, ISO 10303-224, and ISO 10303-240

EXPRESS specification:

```
*)  
ENTITY class  
  SUBTYPE OF (group);  
END_ENTITY;  
(*
```

### 5.2.3.1.17 **contouring\_turning\_operation**

A **contouring\_turning\_operation** is a **turning\_type\_operation**. See the ARM definitions for Contouring and subtypes in ISO 14649-12 for more information.

#### EXPRESS specification:

```

*)
ENTITY contouring_turning_operation
  SUBTYPE OF (turning_type_operation);
  WHERE
  WR1: (SELF.description IN ['roughing','finishing']);

  WR2: (verify_optional_action_property      (SELF, 'allowance')) AND
       (verify_length_measure_action_property (SELF, 'allowance'));

  WR3: NOT (SELF.description = 'roughing') OR
       (verify_required_action_property (SELF, 'allowance'));
END_ENTITY;
(*

```

#### Formal propositions:

**WR1:** The **description** of the **contouring\_turning\_operation** shall be either 'roughing' or 'finishing'.

**WR2:** The **contouring\_turning\_operation** shall be the **definition** of at most one **action\_property** with a **name** of 'allowance', and the **representation** used to describe the **action\_property** shall contain a **representation\_item** of type **measure\_representation\_item** and **length\_measure\_with\_unit**.

**WR3:** If the **description** of the **contouring\_turning\_operation** is 'roughing', the **contouring\_turning\_operation** shall be the **definition** of exactly one **action\_property** with a **name** of 'allowance'.

NOTE This corresponds to local constraints **WR1** on the ARM entity **Contouring\_rough** in ISO 14649-12.

### 5.2.3.1.18 **cylindrical\_shape\_representation**

A **cylindrical\_shape\_representation** specifies representation of a shape that is a cylindrical volume defined as a circular area of a defined length. The enclosed area is defined by a circle with a specified radius.

NOTE This definition has been harmonized with the equivalent definition in ISO 10303-224.

#### EXPRESS specification:

```

*)
ENTITY cylindrical_shape_representation
  SUBTYPE OF (shape_representation_with_parameters);
  WHERE
  WR1: (SIZEOF(SELF.items) = 3);
  WR2: (SIZEOF(QUERY ( it <* SELF.items | ((

```

```

        'INTEGRATED_CNC_SCHEMA.PLACEMENT'
        IN TYPEOF(it)) AND (it.name = 'orientation')) )) = 1);
WR3: (SIZEOF(QUERY ( it <* SELF.items | ((SIZEOF([
        'INTEGRATED_CNC_SCHEMA.MEASURE_REPRESENTATION_ITEM',
        'INTEGRATED_CNC_SCHEMA.LENGTH_MEASURE_WITH_UNIT'] *
        TYPEOF(it)) = 2) AND (it.name = 'length')) )) = 1);
WR4: (SIZEOF(QUERY ( it <* SELF.items | ((SIZEOF([
        'INTEGRATED_CNC_SCHEMA.MEASURE_REPRESENTATION_ITEM',
        'INTEGRATED_CNC_SCHEMA.LENGTH_MEASURE_WITH_UNIT'] *
        TYPEOF(it)) = 2) AND (it.name = 'diameter')) )) = 1);
END_ENTITY; -- cylindrical_shape_representation
(*

```

Formal propositions:

**WR1:** The **cylindrical\_shape\_representation** shall contain exactly three **representation\_items** in its set of **items**.

**WR2:** One of the **representation\_items** used for the implicit representation of a **cylindrical\_shape\_representation** shall be of type **placement** with a **name** of 'orientation'.

**WR3:** One of the **representation\_items** used for the implicit representation of a **cylindrical\_shape\_representation** shall be of type **measure\_representation\_item** and **length\_measure\_with\_unit** with a **name** of 'length'.

**WR4:** One of the **representation\_items** used for the implicit representation of a **cylindrical\_shape\_representation** shall be of type **measure\_representation\_item** and **length\_measure\_with\_unit** with a **name** of 'diameter'.

Informal propositions:

**IP1:** The location of the **cylindrical\_shape\_representation** shall be defined to be at the centre of the circle that defines the cylinder.

**IP2:** The **cylindrical\_shape\_representation** shall be defined by forming a circular profile in the X-Y plane, and the length along the z direction.

### 5.2.3.1.19 directed\_dimensional\_location

A **directed\_dimensional\_location** is a type of **dimensional\_location** that identifies the direction to measure the location dimension.

NOTE This definition has been harmonized with the equivalent definitions in ISO 10303-214, ISO 10303-224, and ISO 10303-1050.

EXPRESS specification:

```

*)
ENTITY directed_dimensional_location
    SUBTYPE OF (dimensional_location);

```

```
END_ENTITY;
(*
```

### 5.2.3.1.20 document\_file

A **document\_file** is a type of **document** and **characterized\_object** that is the representation of the physical document that contains the information about marking, knurl, or thread specifications.

NOTE This definition has been harmonized with the equivalent definition in ISO 10303-224.

#### EXPRESS specification:

\*)

```
ENTITY document_file
  SUBTYPE OF (characterized_object, document);
  WHERE
    WR1: (SIZEOF(QUERY(adr<* QUERY(dr <* USEDIN(SELF,
      'INTEGRATED_CNC_SCHEMA.DOCUMENT_REFERENCE.ASSIGNED_DOCUMENT') |
      'INTEGRATED_CNC_SCHEMA.APPLIED_DOCUMENT_REFERENCE'
      IN TYPEOF(dr)) |
      'INTEGRATED_CNC_SCHEMA.EXTERNALLY_DEFINED_FEATURE_DEFINITION'
      IN TYPEOF(adr.items)
      ))=1) OR
      (SIZEOF(QUERY (duc <* USEDIN(SELF,
      'INTEGRATED_CNC_SCHEMA.DOCUMENT_USAGE_CONSTRAINT.SOURCE') |
      NOT
      (SIZEOF(QUERY(aduc<* QUERY(duca <* USEDIN(duc,
      'INTEGRATED_CNC_SCHEMA.DOCUMENT_USAGE_CONSTRAINT_ASSIGNMENT.'+
      'ASSIGNED_DOCUMENT_USAGE') |
      'INTEGRATED_CNC_SCHEMA.'+
      'APPLIED_DOCUMENT_USAGE_CONSTRAINT_ASSIGNMENT'
      IN TYPEOF(duca)) |
      'INTEGRATED_CNC_SCHEMA.EXTERNALLY_DEFINED_FEATURE_DEFINITION'
      IN TYPEOF(aduc.items)
      ))=1))) = 0);
    WR2: (SIZEOF(QUERY(drt <* USEDIN(SELF,
      'INTEGRATED_CNC_SCHEMA.'+
      'DOCUMENT_REPRESENTATION_TYPE.REPRESENTED_DOCUMENT') |
      (drt.name='physical'))=1);
END_ENTITY; -- document_file
(*
```

#### Formal propositions:

**WR1:** The **document\_file** shall be either the **associated\_document** in exactly one **applied\_document\_reference** that contains one or more **external\_defined\_feature\_definition** in its set of items, or a source in exactly one **applied\_document\_usage\_constraint\_assignment** that contains one or more **external\_defined\_feature\_definition** in its set of items.

**WR2:** The **document\_file** shall be the **represented\_file** in exactly one **document\_representation\_type** with a **name** of 'physical'.

### 5.2.3.1.21 drilling\_operation

A **drilling\_operation** is a type of **drilling\_type\_operation** that represents the details of a machining step in which material is removed perpendicular to the cutting tool axis. See the ARM definitions for **Drilling\_operation** and subtypes in ISO 14649-11 for more information.

#### EXPRESS specification:

```

*)
ENTITY drilling_operation
  SUBTYPE OF (drilling_type_operation);
  WHERE
  WR1: (SELF.description IN ['drilling','counter sinking',
    'center drilling', 'multistep drilling']);

  WR2: NOT (SELF.description = 'multistep drilling') OR
    ((verify_required_action_property (SELF, 'retract distance')) AND
    (verify_length_measure_action_property (SELF, 'retract distance')) AND

    (verify_required_action_property (SELF, 'first depth')) AND
    (verify_length_measure_action_property (SELF, 'first depth')) AND

    (verify_required_action_property (SELF, 'depth of step')) AND
    (verify_length_measure_action_property (SELF, 'depth of step')) AND

    (verify_optional_action_property (SELF, 'dwell time step')) AND
    (verify_rep_type_for_action_property (SELF, 'dwell time step',
    ['INTEGRATED_CNC_SCHEMA.MACHINING_DWELL_TIME_REPRESENTATION'])) AND
    (verify_rep_name_for_action_property (SELF, 'dwell time step',
    ['dwell time']))
  );
END_ENTITY;
(*

```

#### Formal propositions:

**WR1:** The **description** of the **drilling\_operation** shall be either 'drilling','counter sinking', 'center drilling', or 'multistep drilling'.

**WR2:** If the **description** of the **drilling\_operation** is 'multistep drilling', **drilling\_operation** shall satisfy the following conditions:

— the **drilling\_operation** shall be the **definition** of exactly one **action\_property** with a **name** of 'retract distance', and the **representation** used to describe the **action\_property** shall contain a **representation\_item** of type **measure\_representation\_item** and **length\_measure\_with\_unit**;

- the **drilling\_operation** shall be the **definition** of exactly one **action\_property** with a **name** of 'first depth', and the **representation** used to describe the **action\_property** shall contain a **representation\_item** of type **measure\_representation\_item** and **length\_measure\_with\_unit**;
- the **drilling\_operation** shall be the **definition** of exactly one **action\_property** with a **name** of 'depth of step', and the **representation** used to describe the **action\_property** shall contain a **representation\_item** of type **measure\_representation\_item** and **length\_measure\_with\_unit**;
- the **drilling\_operation** shall be the **definition** of at most one **action\_property** with a **name** of 'dwell time step', and the **representation** used to describe the **action\_property** shall be of type **machining\_dwell\_time\_representation** with a **description** of 'dwell time'.

### 5.2.3.1.22 drilling\_type\_operation

A **drilling\_type\_operation** is a type of **machining\_operation** that represents the details of a machining step in which the machine axes are generally only moved parallel to the axis of rotation of the cutting tool. See the ARM definitions for **Drilling\_type\_operation** and subtypes in ISO 14649-11 for more information.

#### EXPRESS specification:

```

*)
ENTITY drilling_type_operation
  SUBTYPE OF (machining_operation);
  WHERE
  WR1: (verify_optional_action_property      (SELF, 'overcut length')) AND
        (verify_length_measure_action_property (SELF, 'overcut length'));

  WR2: (verify_optional_action_property      (SELF, 'cutting depth')) AND
        (verify_length_measure_action_property (SELF, 'cutting depth'));

  WR3: (verify_optional_action_property      (SELF, 'previous diameter')) AND
        (verify_length_measure_action_property (SELF, 'previous diameter'));

  WR4: (verify_optional_action_property      (SELF, 'dwell time bottom')) AND
        (verify_rep_type_for_action_property (SELF, 'dwell time bottom',
        ['INTEGRATED_CNC_SCHEMA.MACHINING_DWELL_TIME_REPRESENTATION'])) AND
        (verify_rep_name_for_action_property (SELF, 'dwell time bottom',
        ['dwell time']));

  WR5: (verify_optional_action_property      (SELF, 'feedrate on retract'))
AND
        (verify_rep_type_for_action_property (SELF, 'feedrate on retract',
        ['INTEGRATED_CNC_SCHEMA.MACHINING_FEED_SPEED_REPRESENTATION'])) AND
        (verify_rep_name_for_action_property (SELF, 'feedrate on retract',
        ['relative speed']));

  WR6: ((verify_optional_relating_amr_with_name (SELF, 'machining',
        ['INTEGRATED_CNC_SCHEMA.MACHINING_STRATEGY_RELATIONSHIP'])) AND
        (verify_related_type_for_amr_with_name (SELF, 'machining',
        ['INTEGRATED_CNC_SCHEMA.MACHINING_STRATEGY_RELATIONSHIP'],

```

```

        ['INTEGRATED_CNC_SCHEMA.DRILLING_TYPE_STRATEGY']))
    );
END_ENTITY;
(*

```

#### Formal propositions:

**WR1:** The **drilling\_type\_operation** shall be the **definition** of at most one **action\_property** with a **name** of 'overcut length', and the **representation** used to describe the **action\_property** shall contain a **representation\_item** of type **measure\_representation\_item** and **length\_measure\_with\_unit**.

**WR2:** The **drilling\_type\_operation** shall be the **definition** of at most one **action\_property** with a **name** of 'cutting depth', and the **representation** used to describe the **action\_property** shall contain a **representation\_item** of type **measure\_representation\_item** and **length\_measure\_with\_unit**.

**WR3:** The **drilling\_type\_operation** shall be the **definition** of at most one **action\_property** with a **name** of 'previous diameter', and the **representation** used to describe the **action\_property** shall contain a **representation\_item** of type **measure\_representation\_item** and **length\_measure\_with\_unit**.

**WR4:** The **drilling\_type\_operation** shall be the **definition** of at most one **action\_property** with a **name** of 'dwell time bottom', and the **representation** used to describe the **action\_property** shall be of type **machining\_dwell\_time\_representation** with a **description** of 'dwell time'.

**WR5:** The **drilling\_type\_operation** shall be the **definition** of at most one **action\_property** with a **name** of 'feedrate on retract', and the **representation** used to describe the **action\_property** shall be of type **machining\_feed\_speed\_representation** with a **description** of 'relative speed'.

**WR6:** The **drilling\_type\_operation** shall be the **relating\_method** of at most one **machining\_strategy\_relationship** with a **name** of 'machining', in which the **related\_method** shall be of type **drilling\_type\_strategy**.

### 5.2.3.1.23 drilling\_type\_strategy

A **drilling\_type\_strategy** is a type of **machining\_strategy** that represents the approach used to determine the motion of the cutting tool during a drilling operation. See the ARM definition for **Drilling\_type\_strategy** in ISO 14649-11 for more information.

#### EXPRESS specification:

```

*)
ENTITY drilling_type_strategy
  SUBTYPE OF (machining_strategy);
  WHERE
  WR1: (verify_optional_action_property (SELF, 'reduced cut at start')) AND
        (verify_rep_type_for_action_property(SELF, 'reduced cut at start',
        ['INTEGRATED_CNC_SCHEMA.MACHINING_SPINDLE_SPEED_REPRESENTATION'])) AND
        (verify_rep_name_for_action_property(SELF, 'reduced cut at start',
        ['relative speed']));

  WR2: (verify_optional_action_property(SELF, 'reduced feedrate at start')) AND

```



```

    (verify_rep_type_for_action_property(SELF, 'reduced feedrate at start',
    ['INTEGRATED_CNC_SCHEMA.MACHINING_FEED_SPEED_REPRESENTATION'])) AND
    (verify_rep_name_for_action_property(SELF, 'reduced feedrate at start',
    ['relative speed']));

WR3:  (verify_optional_action_property      (SELF, 'depth of start')) AND
      (verify_length_measure_action_property (SELF, 'depth of start'));

WR4:  (verify_optional_action_property (SELF, 'reduced cut at end')) AND
      (verify_rep_type_for_action_property (SELF, 'reduced cut at end',
      ['INTEGRATED_CNC_SCHEMA.MACHINING_SPINDLE_SPEED_REPRESENTATION'])) AND
      (verify_rep_name_for_action_property (SELF, 'reduced cut at end',
      ['relative speed']));

WR5:  (verify_optional_action_property (SELF, 'reduced feedrate at end')) AND
      (verify_rep_type_for_action_property(SELF, 'reduced feedrate at end',
      ['INTEGRATED_CNC_SCHEMA.MACHINING_FEED_SPEED_REPRESENTATION'])) AND
      (verify_rep_name_for_action_property(SELF, 'reduced feedrate at end',
      ['relative speed']));

WR6:  (verify_optional_action_property      (SELF, 'depth of end')) AND
      (verify_length_measure_action_property (SELF, 'depth of end'));

WR7:  (verify_required_action_property (SELF, 'depth of start')) OR
      ((0 = SIZEOF (get_action_property (SELF, 'reduced cut at start')) AND
      (0 = SIZEOF (get_action_property (SELF, 'reduced feedrate at start'))));

WR8:  (verify_required_action_property (SELF, 'depth of end')) OR
      ((0 = SIZEOF (get_action_property (SELF, 'reduced cut at end')) AND
      (0 = SIZEOF (get_action_property (SELF, 'reduced feedrate at end'))));
END_ENTITY;
(*

```

#### Formal propositions:

**WR1:** The **drilling\_type\_strategy** shall be the **definition** of at most one **action\_property** with a **name** of 'reduced cut at start', and the **representation** used to describe the **action\_property** shall be of type **machining\_spindle\_speed\_representation** with a **description** of 'relative speed'.

**WR2:** The **drilling\_type\_strategy** shall be the **definition** of at most one **action\_property** with a **name** of 'reduced feedrate at start', and the **representation** used to describe the **action\_property** shall be of type **machining\_feed\_speed\_representation** with a **description** of 'relative speed'.

**WR3:** The **drilling\_type\_strategy** shall be the **definition** of at most one **action\_property** with a **name** of 'depth of start', and the **representation** used to describe the **action\_property** shall contain a **representation\_item** of type **measure\_representation\_item** and **length\_measure\_with\_unit**.

**WR4:** The **drilling\_type\_strategy** shall be the **definition** of at most one **action\_property** with a **name** of 'reduced cut at end', and the **representation** used to describe the **action\_property** shall be of type **machining\_spindle\_speed\_representation** with a **description** of 'relative speed'.

**WR5:** The **drilling\_type\_strategy** shall be the **definition** of at most one **action\_property** with a **name** of 'reduced feedrate at end', and the **representation** used to describe the **action\_property** shall be of type **machining\_feed\_speed\_representation** with a **description** of 'relative speed'.

**WR6:** The **drilling\_type\_strategy** shall be the **definition** of at most one **action\_property** with a **name** of 'depth of end', and the **representation** used to describe the **action\_property** shall contain a **representation\_item** of type **measure\_representation\_item** and **length\_measure\_with\_unit**.

**WR7:** Either the **drilling\_type\_strategy** shall be the **definition** of exactly one **action\_property** with a **name** of 'depth of start', or the **drilling\_type\_strategy** shall be the **definition** of no **action\_properties** with a **name** of either 'reduced cut at start' or 'reduced feedrate at start'.

NOTE This corresponds to local constraint **WR1** on ARM entity **Drilling\_type\_strategy** in ISO 14649-11.

**WR8:** Either the **drilling\_type\_strategy** shall be the **definition** of exactly one **action\_property** with a **name** of 'depth of end', or the **drilling\_type\_strategy** shall be the **definition** of no **action\_properties** with a **name** of either 'reduced cut at end' or 'reduced feedrate at end'.

NOTE This corresponds to local constraint **WR2** on ARM entity **Drilling\_type\_strategy** in ISO 14649-11.

#### 5.2.3.1.24 **expression\_representation\_item**

An **expression\_representation\_item** is a **representation\_item** and **generic\_expression** where a particular expression value is represented.

NOTE The **expression\_representation\_item** definition ties together **representation\_item** and the PLIB ISO 13584-20 expression definitions for use in representations. Using a complex instance, one can combine a subtype of **generic\_expression** with **expression\_representation\_item** to produce a expression that can appear in the representation of a property. This technique is analogous to the way **measure\_representation\_item** is combined with a **measure\_with\_unit** subtype, such as **length\_measure\_with\_unit**, in the representation of a property.

#### EXPRESS specification:

```
*)  
ENTITY expression_representation_item  
  SUBTYPE OF (representation_item, generic_expression);  
END_ENTITY;  
(*
```

#### 5.2.3.1.25 **externally\_defined\_class**

An **externally\_defined\_class** is a type of **externally\_defined\_item** and **class** that represents classification information whose identification and definition is defined externally, i.e., not within this part of ISO 10303.

NOTE This definition has been harmonized with the equivalent definitions in ISO 10303-214, ISO 10303-224, and ISO 10303-240.

EXPRESS specification:

```

*)
ENTITY externally_defined_class
  SUBTYPE OF (externally_defined_item,class);
  WHERE
  WR1: 'INTEGRATED_CNC_SCHEMA.KNOWN_SOURCE' IN TYPEOF(SELF.source);
  WR2: SELF.source.name = 'ISO 13584 library';

  WR3: ( SIZEOF ( QUERY ( aoa <* USEDIN ( SELF.source,
    'INTEGRATED_CNC_SCHEMA.APPLIED_ORGANIZATION_ASSIGNMENT.ITEMS' ) |
    (aoa.role.name = 'library supplier')))=1);

  WR4: (SIZEOF ( QUERY ( aoa <* USEDIN ( SELF, 'INTEGRATED_CNC_SCHEMA.'+
    'APPLIED_EXTERNAL_IDENTIFICATION_ASSIGNMENT.ITEMS' ) |
    (aoa.role.name = 'class version')))=1);
END_ENTITY;
(*

```

Formal propositions:

**WR1:** The **externally\_defined\_class** shall have as **source** an instance of **known\_source**.

**WR2:** The **externally\_defined\_class** shall have as **source** an instance of **known\_source** with a **name** of 'ISO 13584 library'.

**WR3:** The **externally\_defined\_class** shall have as **source** attribute an instance that is referenced by the **items** set of exactly one **applied\_organization\_assignment** that has an **organization\_role** with a **name** of 'library supplier'.

**WR4:** The **externally\_defined\_class** shall be referenced by the **items** set of exactly one **applied\_external\_identification\_assignment** with an **identification\_role** with **name** of 'class version'.

**5.2.3.1.26 externally\_defined\_dimension\_definition**

An **externally\_defined\_dimension\_definition** is a **dimensional\_size** and **externally\_defined\_item** that represents a type of size dimension that is defined by an external document.

**NOTE** This definition has been harmonized with the equivalent definitions in ISO 10303-214, ISO 10303-224, and ISO 10303-1050.

EXPRESS specification:

```

*)
ENTITY externally_defined_dimension_definition
  SUBTYPE OF (externally_defined_item, dimensional_size);
  WHERE
  WR1: (SELF\externally_defined_item.item_id =
    'external size dimension') AND
    (SELF\externally_defined_item.source.source_id =

```

```

        'external size dimension specification');

WR2: 1 >= SIZEOF(QUERY ( adr <* USEDIN(SELF,
    'INTEGRATED_CNC_SCHEMA.APPLIED_DOCUMENT_REFERENCE.ITEMS') |
    (adr.assigned_document.description =
    'external size dimension specification')
    ));
END_ENTITY;
(*

```

#### Formal propositions:

**WR1:** The **externally\_defined\_dimension\_definition** shall have an **item\_id** of 'external size dimension' and shall have as **source** an instance of **external\_source** with a **source\_id** of 'external size dimension specification'.

**WR2:** The **externally\_defined\_dimension\_definition** shall appear in the **items** set of at most one **applied\_document\_reference** in which the **assigned\_document** has a **description** of 'external size dimension specification'.

### 5.2.3.1.27 externally\_defined\_general\_property

An **externally\_defined\_general\_property** is a type of **general\_property** and **externally\_defined\_item** that represents general property definition information which is defined externally, i.e., not within this part of ISO 10303.

NOTE This definition has been harmonized with the equivalent definitions in ISO 10303-214, ISO 10303-224, and ISO 10303-240.

#### EXPRESS specification:

```

*)
ENTITY externally_defined_general_property
  SUBTYPE OF (general_property, externally_defined_item);
  WHERE
  WR1: 'INTEGRATED_CNC_SCHEMA.KNOWN_SOURCE' IN TYPEOF(SELF.source);
  WR2: SELF.source.name = 'ISO 13584 library';

  WR3: (SIZEOF (QUERY ( aoa <* USEDIN ( SELF, 'INTEGRATED_CNC_SCHEMA.'+
    'APPLIED_EXTERNAL_IDENTIFICATION_ASSIGNMENT.ITEMS' ) |
    (aoa.role.name = 'property version' )))=1);

  WR4: (SIZEOF(QUERY ( ap <* USEDIN(SELF, 'INTEGRATED_CNC_SCHEMA.'+
    'EXTERNALLY_DEFINED_ITEM_RELATIONSHIP.RELATING_ITEM') |
    ((ap.name='name scope') AND
    ('INTEGRATED_CNC_SCHEMA.EXTERNALLY_DEFINED_CLASS' IN
    TYPEOF(ap.related_item) )))>=1);

END_ENTITY;
(*

```

Formal propositions:

**WR1:** The **externally\_defined\_general\_property** shall have as **source** an instance of **known\_source**.

**WR2:** The **externally\_defined\_general\_property** shall have as **source** an instance of **known\_source** with a **name** of 'ISO 13584 library'.

**WR3:** The **externally\_defined\_general\_property** shall be referenced by the **items** set of exactly one **applied\_external\_identification\_assignment** with an **identification\_role** with **name** of 'property version'.

**WR4:** The **externally\_defined\_general\_property** shall be referenced as the **relating\_item** of at least one **externally\_defined\_item\_relationship** with **name** of 'name scope' and **related\_item** of type **externally\_defined\_class**.

### 5.2.3.1.28 externally\_defined\_representation\_with\_parameters

An **externally\_defined\_representation\_with\_parameters** is a type of **representation** that defines placement and orientation for an external reference.

NOTE This definition has been harmonized with the equivalent definitions in ISO 10303-224 and ISO 10303-240.

EXPRESS specification:

```

*)
ENTITY externally_defined_representation_with_parameters
  SUBTYPE OF (representation);
  WHERE
  WR1: (SIZEOF(USEDIN(SELF, 'INTEGRATED_CNC_SCHEMA.'+
    'APPLIED_CLASSIFICATION_ASSIGNMENT.ITEMS')) = 1);

  WR2: (SIZEOF (QUERY(adr <* SELF.items|
    'INTEGRATED_CNC_SCHEMA.PLACEMENT' IN TYPEOF(adr))) <=1);
END_ENTITY;
(*

```

Formal propositions:

**WR1:** The **externally\_defined\_representation\_with\_parameters** shall be referenced by the **items** set of exactly one **applied\_classification\_assignment**.

**WR2:** The **externally\_defined\_representation\_with\_parameters items** set shall contain at most one **placement** instance.

### 5.2.3.1.29 facing\_turning\_operation

A **facing\_turning\_operation** is a **turning\_type\_operation**. See the ARM definitions for Facing and subtypes in ISO 14649-12 for more information.

EXPRESS specification:

```

*)
ENTITY facing_turning_operation
  SUBTYPE OF (turning_type_operation);
  WHERE
  WR1: (SELF.description IN ['roughing','finishing']);

  WR2: (verify_optional_action_property (SELF, 'allowance')) AND
        (verify_length_measure_action_property (SELF, 'allowance'));

  WR3: NOT (SELF.description = 'roughing') OR
        (verify_required_action_property (SELF, 'allowance'));
END_ENTITY;
(*

```

Formal propositions:

**WR1:** The **description** of the **facing\_turning\_operation** shall be either 'roughing' or 'finishing'.

**WR2:** The **facing\_turning\_operation** shall be the **definition** of at most one **action\_property** with a **name** of 'allowance', and the **representation** used to describe the **action\_property** shall contain a **representation\_item** of type **measure\_representation\_item** and **length\_measure\_with\_unit**.

**WR3:** If the **description** of the **facing\_turning\_operation** is 'cutting in', the **facing\_turning\_operation** shall be the **definition** of exactly one **action\_property** with a **name** of 'allowance'.

NOTE This corresponds to local constraints **WR1** on the ARM entity **Facing\_rough** in ISO 14649-12.

### 5.2.3.1.30 freeform\_milling\_operation

A **freeform\_milling\_operation** is a **milling\_type\_operation** that describes a milling step in which material is removed to create freeform surface geometry. See the ARM definition for **Freeform\_milling\_operation** in ISO 14649-11 for more information.

EXPRESS specification:

```

*)
ENTITY freeform_milling_operation
  SUBTYPE OF (milling_type_operation);
  WHERE
  WR1: ((verify_optional_relatng_amr_with_name (SELF, 'machining',
        ['INTEGRATED_CNC_SCHEMA.MACHINING_STRATEGY_RELATIONSHIP'])) AND
        (verify_related_type_for_amr_with_name (SELF, 'machining',
        ['INTEGRATED_CNC_SCHEMA.MACHINING_STRATEGY_RELATIONSHIP'],
        ['INTEGRATED_CNC_SCHEMA.FREEFORM_MILLING_STRATEGY'])))
        );
END_ENTITY;
(*

```

Formal propositions:

**WR1:** The **freeform\_milling\_operation** shall be the **relating\_method** of at most one **machining\_strategy\_relationship** with a **name** of 'machining', in which the **related\_method** shall be of type **freeform\_milling\_strategy**.

**5.2.3.1.31 freeform\_milling\_strategy**

A **freeform\_milling\_strategy** is a type of **milling\_type\_strategy** that represents the approach used to determine the motion of the cutting tool during a freeform milling operation. See the ARM definitions for **Freeform\_strategy** and subtypes in ISO 14649-11 for more information.

EXPRESS specification:

\*)

```

ENTITY freeform_milling_strategy
  SUBTYPE OF (milling_type_strategy);
  WHERE
    WR1: NOT (SELF.description IN ['leading line', 'plane cutter contact',
      'plane cutter location', 'uv']) OR
      ((verify_required_action_property      (SELF, 'pathmode')) AND
      (verify_enumeration_action_property    (SELF, 'pathmode',
        ['forward', 'zigzag']))) AND

      (verify_required_action_property      (SELF, 'cutmode')) AND
      (verify_enumeration_action_property    (SELF, 'cutmode',
        ['climb', 'conventional']))) AND

      (verify_required_action_property      (SELF, 'milling tolerances')) AND
      (verify_rep_type_for_action_property   (SELF, 'milling tolerances',
        ['INTEGRATED_CNC_SCHEMA.FREEFORM_MILLING_TOLERANCE_REPRESENTATION'])) AND

      (verify_optional_action_property      (SELF, 'stepover length')) AND
      (verify_length_measure_action_property (SELF, 'stepover length')) );

    WR2: NOT (SELF.description = 'leading line') OR
      ((verify_required_action_property      (SELF, 'leading line')) AND
      (verify_rep_item_for_action_property   (SELF, 'leading line',
        ['INTEGRATED_CNC_SCHEMA.BOUNDED_CURVE']))) );

    WR3: NOT (SELF.description IN ['plane cutter contact',
      'plane cutter location']) OR
      ((verify_required_action_property      (SELF, 'plane normal')) AND
      (verify_rep_item_for_action_property   (SELF, 'plane normal',
        ['INTEGRATED_CNC_SCHEMA.DIRECTION']))) );

    WR4: NOT (SELF.description = 'uv') OR
      ((verify_required_action_property      (SELF, 'forward direction')) AND
      (verify_rep_item_for_action_property   (SELF, 'forward direction',
        ['INTEGRATED_CNC_SCHEMA.DIRECTION']))) AND

      (verify_required_action_property      (SELF, 'sideward direction')) AND

```

```
(verify_rep_item_for_action_property (SELF, 'sideward direction',
    ['INTEGRATED_CNC_SCHEMA.DIRECTION'])) );
END_ENTITY;
(*
```

Formal propositions:

**WR1:** If the **description** of the **freeform\_milling\_strategy** is either 'leading line', 'plane cutter contact', 'plane cutter location', or 'uv', the **freeform\_milling\_strategy** shall satisfy the following conditions:

- the **freeform\_milling\_strategy** shall be the **definition** of exactly one **action\_property** with a **name** of 'pathmode', and the **representation** used to describe the **action\_property** shall contain a **representation\_item** of type **descriptive\_representation\_item** with a **description** of 'forward' or 'zigzag';
- the **freeform\_milling\_strategy** shall be the **definition** of exactly one **action\_property** with a **name** of 'cutmode', and the **representation** used to describe the **action\_property** shall contain a **representation\_item** of type **descriptive\_representation\_item** with a **description** of 'climb' or 'conventional';
- the **freeform\_milling\_strategy** shall be the **definition** of exactly one **action\_property** with a **name** of 'milling tolerances', and the **representation** used to describe the **action\_property** shall be of type **freeform\_milling\_tolerance\_representation**;
- the **freeform\_milling\_strategy** shall be the **definition** of at most one **action\_property** with a **name** of 'stepover length', and the **representation** used to describe the **action\_property** shall contain a **representation\_item** of type **measure\_representation\_item** and **length\_measure\_with\_unit**.

**WR2:** If the **description** of the **freeform\_milling\_strategy** is 'leading line', the **freeform\_milling\_strategy** shall be the **definition** of exactly one **action\_property** with a **name** of 'leading line', and the **representation** used to describe the **action\_property** shall contain a **representation\_item** of type **bounded\_curve**.

**WR3:** If the **description** of the **freeform\_milling\_strategy** is either 'plane cutter contact' or 'plane cutter location', the **freeform\_milling\_strategy** shall be the **definition** of exactly one **action\_property** with a **name** of 'plane normal', and the **representation** used to describe the **action\_property** shall contain a **representation\_item** of type **direction**.

**WR4:** If the **description** of the **freeform\_milling\_strategy** is 'uv', the **freeform\_milling\_strategy** shall satisfy the following conditions:

- the **freeform\_milling\_strategy** shall be the **definition** of exactly one **action\_property** with a **name** of 'forward direction', and the **representation** used to describe the **action\_property** shall contain a **representation\_item** of type **direction**;
- the **freeform\_milling\_strategy** shall be the **definition** of exactly one **action\_property** with a **name** of 'sideward direction', and the **representation** used to describe the **action\_property** shall contain a **representation\_item** of type **direction**.



### 5.2.3.1.32 freeform\_milling\_tolerance\_representation

A **freeform\_milling\_tolerance\_representation** is a type of **representation** that represents surface approximation tolerance parameters for freeform machining. See the ARM definition for Tolerances in ISO 14649-11 for more information.

#### EXPRESS specification:

```
*)
ENTITY freeform_milling_tolerance_representation
  SUBTYPE OF (representation);
  WHERE
  WR1:  (verify_required_rep_item      (SELF, 'chordal tolerance')) AND
        (verify_length_measure_rep_item (SELF, 'chordal tolerance'));

  WR2:  (verify_required_rep_item      (SELF, 'scallop height')) AND
        (verify_length_measure_rep_item (SELF, 'scallop height'));
END_ENTITY;
(*
```

#### Formal propositions:

**WR1:** The **items** set shall contain exactly one **representation\_item** with a **name** of 'chordal tolerance', which shall be of type **measure\_representation\_item** and **length\_measure\_with\_unit**.

**WR2:** The **items** set shall contain exactly one **representation\_item** with a **name** of 'scallop height', which shall be of type **measure\_representation\_item** and **length\_measure\_with\_unit**.

### 5.2.3.1.33 grooving\_turning\_operation

A **grooving\_turning\_operation** is a **turning\_type\_operation**. See the ARM definitions for Grooving and subtypes in ISO 14649-12 for more information.

#### EXPRESS specification:

```
*)
ENTITY grooving_turning_operation
  SUBTYPE OF (turning_type_operation);
  WHERE
  WR1:  (SELF.description IN ['roughing', 'finishing', 'cutting in']);

  WR2:  (verify_optional_action_property      (SELF, 'dwell')) AND
        (verify_rep_type_for_action_property (SELF, 'dwell',
        ['INTEGRATED_CNC_SCHEMA.MACHINING_DWELL_TIME_REPRESENTATION']));

  WR3:  (verify_optional_action_property      (SELF, 'allowance')) AND
        (verify_length_measure_action_property (SELF, 'allowance'));

  -- allowance property required for roughing
  WR4:  NOT (SELF.description = 'roughing') OR
        (verify_required_action_property (SELF, 'allowance'));
```

ISO 10303-238:2007(E)

```
-- allowance property forbidden for cutting in
WR5: NOT (SELF.description = 'cutting in') OR
      (0 = SIZEOF (get_action_property (SELF, 'allowance')));
END_ENTITY;
(*
```

Formal propositions:

**WR1:** The **description** of the **grooving\_turning\_operation** shall be either 'roughing', 'finishing' or 'cutting in'.

**WR2:** The **grooving\_turning\_operation** shall be the **definition** of at most one **action\_property** with a **name** of 'dwell', and the **representation** used to describe the **action\_property** shall be of type **turning\_dwell\_time\_representation**.

**WR3:** The **grooving\_turning\_operation** shall be the **definition** of at most one **action\_property** with a **name** of 'allowance', and the **representation** used to describe the **action\_property** shall contain a **representation\_item** of type **measure\_representation\_item** and **length\_measure\_with\_unit**.

**WR4:** If the **description** of the **grooving\_turning\_operation** is 'roughing', the **grooving\_turning\_operation** shall be the **definition** of exactly one **action\_property** with a **name** of 'allowance'.

NOTE This corresponds to local constraints **WR1** on the ARM entity **Grooving\_rough** in ISO 14649-12.

**WR5:** If the **description** of the **grooving\_turning\_operation** is 'cutting in', the **grooving\_turning\_operation** shall be the **definition** of no **action\_property** with a **name** of 'allowance'.

NOTE This corresponds to local constraints **WR1** on the ARM entity **Cutting\_in** in ISO 14649-12.

### 5.2.3.1.34 known\_source

A **known\_source** is a type of **external\_source** and of **pre\_defined\_item** that is a source of information whose name and content are predetermined. It provides a mechanism to refer to an entry in an external library.

NOTE This definition has been harmonized with the equivalent definition in ISO 10303-214, ISO 10303-224, and ISO 10303-240

EXPRESS specification:

```
*)
ENTITY known_source
  SUBTYPE OF (external_source,pre_defined_item);
END_ENTITY;
(*
```

### 5.2.3.1.35 knurling\_turning\_operation

A **knurling\_turning\_operation** is a **turning\_type\_operation**. See the ARM definitions for Knurling in ISO 14649-12 for more information.

#### EXPRESS specification:

```
*)
ENTITY knurling_turning_operation
  SUBTYPE OF (turning_type_operation);
END_ENTITY;
(*
```

### 5.2.3.1.36 machining\_adaptive\_control\_relationship

A **machining\_adaptive\_control\_relationship** is a type of **action\_method\_relationship** that represents the use of an Adaptive\_control description in some context. See the ARM definitions for the Technology subtypes in ISO 14649-11 and ISO 14649-12 for more information.

#### EXPRESS specification:

```
*)
ENTITY machining_adaptive_control_relationship
  SUBTYPE OF (action_method_relationship);
END_ENTITY;
(*
```

### 5.2.3.1.37 machining\_approach\_retract\_strategy

A **machining\_approach\_retract\_strategy** is a type of **machining\_strategy** that represents the manner in which a cutting tool approaches the workpiece at the beginning of a machining process step or retracts from the workpiece at the end of a machining process step. See the ARM definitions for Approach\_retract\_strategy and subtypes in ISO 14649-11 for more information.

#### EXPRESS specification:

```
*)
ENTITY machining_approach_retract_strategy
  SUBTYPE OF (machining_strategy);
  WHERE
    WR1: (SELF.description IN ['along path',
      'approach retract angle', 'approach retract tangent',
      'plunge helix', 'plunge ramp', 'plunge toolaxis',
      'plunge zigzag']);

    WR2: (verify_optional_action_property (SELF, 'tool orientation')) AND
      (verify_rep_item_for_action_property (SELF, 'tool orientation',
        ['INTEGRATED_CNC_SCHEMA.DIRECTION']));

    WR3: NOT (SELF.description = 'along path') OR
```

```

        ((1 <= get_count_of_relating_amr (SELF,
            ['INTEGRATED_CNC_SCHEMA.MACHINING_TOOLPATH_SEQUENCE_RELATIONSHIP']))
AND
        (verify_related_type_for_amr (SELF,
            ['INTEGRATED_CNC_SCHEMA.MACHINING_TOOLPATH_SEQUENCE_RELATIONSHIP'],
            ['INTEGRATED_CNC_SCHEMA.MACHINING_TOOLPATH']))
        );

WR4: NOT (SELF.description = 'approach retract angle') OR
        ((verify_required_action_property (SELF, 'travel angle') AND
            (verify_angle_measure_action_property (SELF, 'travel angle') AND

            (verify_required_action_property (SELF, 'travel length') AND
            (verify_length_measure_action_property (SELF, 'travel length'))));

WR5: NOT (SELF.description = 'approach retract tangent') OR
        ((verify_required_action_property (SELF, 'travel radius') AND
            (verify_length_measure_action_property (SELF, 'travel radius')));

WR6: NOT (SELF.description IN ['plunge helix', 'plunge ramp', 'plunge
zigzag']) OR
        ((verify_required_action_property (SELF, 'plunge angle') AND
            (verify_angle_measure_action_property (SELF, 'plunge angle')));

WR7: NOT (SELF.description = 'plunge helix') OR
        ((verify_required_action_property (SELF, 'plunge radius') AND
            (verify_length_measure_action_property (SELF, 'plunge radius')));

WR8: NOT (SELF.description = 'plunge zigzag') OR
        ((verify_required_action_property (SELF, 'plunge width') AND
            (verify_length_measure_action_property (SELF, 'plunge width')));
END_ENTITY;
(*

```

Formal propositions:

**WR1:** The **description** of the **machining\_approach\_retract\_strategy** shall be either 'along path', 'approach retract angle', 'approach retract tangent', 'plunge helix', 'plunge ramp', 'plunge toolaxis', or 'plunge zigzag'.

**WR2:** The **machining\_approach\_retract\_strategy** shall be the **definition** of at most one **action\_property** with a **name** of 'tool orientation', and the **representation** used to describe the **action\_property** shall contain a **representation\_item** of type **direction**.

**WR3:** If the **description** of the **machining\_approach\_retract\_strategy** is 'along path', the **machining\_approach\_retract\_strategy** shall be the **relating\_method** of at least one **machining\_toolpath\_sequence\_relationship**, in which **related\_method** is of type **machining\_toolpath**.

**WR4:** If the **description** of the **machining\_approach\_retract\_strategy** is 'approach retract angle', the **machining\_approach\_retract\_strategy** shall satisfy the following conditions:

- the **machining\_approach\_retract\_strategy** shall be the **definition** of exactly one **action\_property** with a **name** of 'travel angle', and the **representation** used to describe the **action\_property** shall contain a **representation\_item** of type **measure\_representation\_item** and **plane\_angle\_measure\_with\_unit**;
- the **machining\_approach\_retract\_strategy** shall be the **definition** of exactly one **action\_property** with a **name** of 'travel length', and the **representation** used to describe the **action\_property** shall contain a **representation\_item** of type **measure\_representation\_item** and **length\_measure\_with\_unit**.

**WR5:** If the **description** of the **machining\_approach\_retract\_strategy** is 'approach retract tangent', the **machining\_approach\_retract\_strategy** shall be the **definition** of exactly one **action\_property** with a **name** of 'travel radius', and the **representation** used to describe the **action\_property** shall contain a **representation\_item** of type **measure\_representation\_item** and **length\_measure\_with\_unit**.

**WR6:** If the **description** of the **machining\_approach\_retract\_strategy** is either 'plunge helix', 'plunge ramp', or 'plunge zigzag', the **machining\_approach\_retract\_strategy** shall be the **definition** of exactly one **action\_property** with a **name** of 'plunge angle', and the **representation** used to describe the **action\_property** shall contain a **representation\_item** of type **measure\_representation\_item** and **plane\_angle\_measure\_with\_unit**.

**WR7:** If the **description** of the **machining\_approach\_retract\_strategy** is 'plunge helix', the **machining\_approach\_retract\_strategy** shall be the **definition** of exactly one **action\_property** with a **name** of 'plunge radius', and the **representation** used to describe the **action\_property** shall contain a **representation\_item** of type **measure\_representation\_item** and **length\_measure\_with\_unit**.

**WR8:** If the **description** of the **machining\_approach\_retract\_strategy** is 'plunge zigzag', the **machining\_approach\_retract\_strategy** shall be the **definition** of exactly one **action\_property** with a **name** of 'plunge width', and the **representation** used to describe the **action\_property** shall contain a **representation\_item** of type **measure\_representation\_item** and **length\_measure\_with\_unit**.

#### Informal propositions:

**IP1:** All **machining\_toolpath\_sequence\_relationship** instances which refer to the same **machining\_approach\_retract\_strategy** through **relating\_method** shall have unique **sequence\_position** values.

### 5.2.3.1.38 machining\_cutting\_component

A **machining\_cutting\_component** is a type of **action\_resource** and **characterized\_object** that represents the cutting edge characteristics of a tool for machining. See the ARM definitions for **Cutting\_component** in ISO 14649-111 and **Cutting\_edge\_properties** in ISO 14649-121 for more information.

#### EXPRESS specification:

```
*)
ENTITY machining_cutting_component
  SUBTYPE OF (action_resource, characterized_object);
  WHERE
```

```

WR1:  (1 >= SIZEOF (USEDIN (SELF, 'INTEGRATED_CNC_SCHEMA.' +
      'MATERIAL_DESIGNATION.DEFINITIONS')));

WR2:  (1 >= SIZEOF (QUERY (arr <* USEDIN (SELF,
      'INTEGRATED_CNC_SCHEMA.REQUIREMENT_FOR_ACTION_RESOURCE.RESOURCES') |
      (arr.kind.name = 'cutting component') AND
      (0 < SIZEOF (QUERY (mt <* arr.operations |
      'INTEGRATED_CNC_SCHEMA.MACHINING_TECHNOLOGY' IN TYPEOF (mt))))
      )));

WR3:  (verify_optional_resource_property      (SELF, 'expected life')) AND
      (verify_time_measure_resource_property (SELF, 'expected life'));

WR4:  NOT (SELF.kind.name = 'milling cutting edge') OR
      ((verify_required_resource_property
        (SELF, 'functional length')) AND
        (verify_length_measure_resource_property
        (SELF, 'functional length'))
      );

WR5:  NOT (SELF.kind.name = 'turning cutting edge') OR
      ((verify_optional_resource_property
        (SELF, 'cutting edge length')) AND
        (verify_length_measure_resource_property
        (SELF, 'cutting edge length')) AND

        (verify_optional_resource_property
        (SELF, 'cutting edge angle')) AND
        (verify_angle_measure_resource_property
        (SELF, 'cutting edge angle')) AND

        (verify_optional_resource_property
        (SELF, 'cutting edge angle type')) AND
        (verify_rep_item_for_resource_property
        (SELF, 'cutting edge angle type',
        ['INTEGRATED_CNC_SCHEMA.DESRIPTIVE_REPRESENTATION_ITEM'])) AND

        (verify_optional_resource_property
        (SELF, 'tool included angle')) AND
        (verify_angle_measure_resource_property
        (SELF, 'tool included angle')) AND

        (verify_rep_type_for_resource_property
        (SELF, 'corner transitions',
        ['INTEGRATED_CNC_SCHEMA.' +
        'MACHINING_CUTTING_CORNER_REPRESENTATION'])) AND

        (verify_optional_resource_property
        (SELF, 'maximum side cutting depth')) AND
        (verify_length_measure_resource_property
        (SELF, 'maximum side cutting depth')) AND

        (verify_optional_resource_property

```

```

        (SELF, 'maximum end cutting depth')) AND
        (verify_length_measure_resource_property
         (SELF, 'maximum end cutting depth'))
    );
END_ENTITY;
(*

```

#### Formal propositions:

**WR1:** The **machining\_cutting\_component** appears in the set of **definitions** of at most one **material\_designation**.

**WR2:** The **machining\_cutting\_component** appears in the set of **resources** in at least one **action\_resource\_requirement** in which the **resource\_requirement\_type** has a **name** of 'cutting component' and the set of **operations** contains exactly one **machining\_technology**

**WR3:** The **machining\_cutting\_component** is the **resource** of at most one **resource\_property** with a **name** of 'expected life', and the **representation** used to describe the **resource\_property** shall contain a **representation\_item** of type **measure\_representation\_item** and **time\_measure\_with\_unit**.

**WR4:** If the **kind** of the **machining\_cutting\_component** is an **action\_resource\_type** with a **name** of 'milling cutting edge', the **machining\_cutting\_component** shall satisfy the following conditions:

— the **machining\_cutting\_component** is the **resource** of exactly one **resource\_property** with a **name** of 'functional length', and the **representation** used to describe the **resource\_property** shall contain a **representation\_item** of type **measure\_representation\_item** and **length\_measure\_with\_unit**.

**WR5:** If the **kind** of the **machining\_cutting\_component** is an **action\_resource\_type** with a **name** of 'turning cutting edge', the **machining\_cutting\_component** shall satisfy the following conditions:

— the **machining\_cutting\_component** is the **resource** of at most one **resource\_property** with a **name** of 'cutting edge length', and the **representation** used to describe the **resource\_property** shall contain a **representation\_item** of type **measure\_representation\_item** and **length\_measure\_with\_unit**;

— the **machining\_cutting\_component** is the **resource** of at most one **resource\_property** with a **name** of 'cutting edge angle', and the **representation** used to describe the **resource\_property** shall contain a **representation\_item** of type **measure\_representation\_item** and **plane\_angle\_measure\_with\_unit**;

— the **machining\_cutting\_component** is the **resource** of at most one **resource\_property** with a **name** of 'cutting edge angle type', and the **representation** used to describe the **resource\_property** shall contain a **representation\_item** of type **descriptive\_representation\_item**;

— the **machining\_cutting\_component** is the **resource** of at most one **resource\_property** with a **name** of 'tool included angle', and the **representation** used to describe the **resource\_property** shall contain a **representation\_item** of type **measure\_representation\_item** and **plane\_angle\_measure\_with\_unit**;

- the **machining\_cutting\_component** is the **resource** of zero or more **resource\_property** with a **name** of 'corner transitions', and the **representation** used to describe the **resource\_property** shall be of type **machining\_cutting\_corner\_representation**;
- the **machining\_cutting\_component** is the **resource** of at most one **resource\_property** with a **name** of 'maximum side cutting depth', and the **representation** used to describe the **resource\_property** shall contain a **representation\_item** of type **measure\_representation\_item** and **length\_measure\_with\_unit**;
- the **machining\_cutting\_component** is the **resource** of at most one **resource\_property** with a **name** of 'maximum end cutting depth', and the **representation** used to describe the **resource\_property** shall contain a **representation\_item** of type **measure\_representation\_item** and **length\_measure\_with\_unit**.

### 5.2.3.1.39 machining\_cutting\_corner\_representation

A **machining\_cutting\_corner\_representation** is a type of **representation** that represents the corner transitions of a cutting edge of a tool for machining. See the ARM definition for **Corner\_transition** in ISO 14649-12 for more information.

#### EXPRESS specification:

```

*)
ENTITY machining_cutting_corner_representation
  SUBTYPE OF (representation);
  WHERE
  WR1: ((verify_required_rep_item      (SELF, 'corner identity')) AND
        (verify_count_measure_rep_item (SELF, 'corner identity'))
        );

  WR2: NOT (SELF.name = 'chamfered corner') OR
        ((verify_required_rep_item      (SELF, 'chamfer angle')) AND
         (verify_angle_measure_rep_item  (SELF, 'chamfer angle')) AND

         (verify_optional_rep_item      (SELF, 'chamfer length')) AND
         (verify_length_measure_rep_item (SELF, 'chamfer length')) AND

         (verify_optional_rep_item      (SELF, 'chamfer width')) AND
         (verify_length_measure_rep_item (SELF, 'chamfer width'))
        );

  WR3: NOT (SELF.name = 'rounded corner') OR
        ((verify_required_rep_item      (SELF, 'radius')) AND
         (verify_length_measure_rep_item (SELF, 'radius'))
        );

  WR4: NOT (SELF.name = 'profiled corner') OR
        (1 = SIZEOF (QUERY (prep <* USEDIN (SELF, 'INTEGRATED_CNC_SCHEMA.' +
        'PROPERTY_DEFINITION_REPRESENTATION.USED_REPRESENTATION') |
        (('INTEGRATED_CNC_SCHEMA.LINEAR_PROFILE'
         IN TYPEOF(prepare.definition)) OR

```



```

('INTEGRATED_CNC_SCHEMA.OPEN_PATH_PROFILE'
 IN TYPEOF(prepare.definition)) OR
('INTEGRATED_CNC_SCHEMA.PARTIAL_CIRCULAR_PROFILE'
 IN TYPEOF(prepare.definition)) OR
('INTEGRATED_CNC_SCHEMA.ROUNDED_U_PROFILE'
 IN TYPEOF(prepare.definition)) OR
('INTEGRATED_CNC_SCHEMA.SQUARE_U_PROFILE'
 IN TYPEOF(prepare.definition)) OR
('INTEGRATED_CNC_SCHEMA.TEE_PROFILE'
 IN TYPEOF(prepare.definition)) OR
('INTEGRATED_CNC_SCHEMA.VEE_PROFILE'
 IN TYPEOF(prepare.definition))
));
END_ENTITY;
(*

```

### Formal propositions:

**WR1:** The **items** set shall contain exactly one **representation\_item** with a **name** of 'corner identity', which shall be of type **measure\_representation\_item** with a **value\_component** of type **count\_measure**.

**WR2:** If the **name** of the **machining\_cutting\_corner\_representation** is 'chamfered corner', the **items** set shall contain the following items:

- exactly one **representation\_item** with a **name** of 'chamfer angle', which shall be of type **measure\_representation\_item** and **plane\_angle\_measure\_with\_unit**;
- at most one **representation\_item** with a **name** of 'chamfer length', which shall be of type **measure\_representation\_item** and **length\_measure\_with\_unit**;
- at most one **representation\_item** with a **name** of 'chamfer width', which shall be of type **measure\_representation\_item** and **length\_measure\_with\_unit**.

**WR3:** If the **name** of the **machining\_cutting\_corner\_representation** is 'rounded corner', the **items** set shall contain exactly one **representation\_item** with a **name** of 'radius', which shall be of type **measure\_representation\_item** and **length\_measure\_with\_unit**;

**WR4:** If the **name** of the **machining\_cutting\_corner\_representation** is 'profiled corner', the **machining\_cutting\_corner\_representation** shall be the **used\_representation** of exactly one **property\_definition\_representation** in which the **definition** refers to a **shape\_aspect** which shall be of type **linear\_profile**, **open\_path\_profile**, **partial\_circular\_profile**, **rounded\_u\_profile**, **square\_u\_profile**, **tee\_profile**, or **vee\_profile**.

### **5.2.3.1.40 machining\_dwell\_time\_representation**

A **machining\_dwell\_time\_representation** is a type of **representation** that represents the duration of time that a machine tool performs some action. The dwell time is described as one of the following:

— as a time measure, as described by the ARM definitions for the Feedstop "dwell" attribute in ISO 14649-10, the Multistep\_drilling "dwell\_time\_step" and Drilling\_type\_operation "dwell\_time\_bottom" attributes in ISO 14649-11, and Dwell\_time in ISO 14649-12;

— as a count of spindle revolutions, as described by the ARM definitions for Dwell\_revolution in ISO 14649-12.

EXPRESS specification:

```

*)
ENTITY machining_dwell_time_representation
  SUBTYPE OF (representation);
  WHERE
  WR1: (SELF.name IN ['dwell time', 'dwell revolution']);

  WR2: NOT (SELF.name = 'dwell time') OR
        ((verify_required_rep_item      (SELF, 'dwell time')) AND
         (verify_time_measure_rep_item   (SELF, 'dwell time'))
        );

  WR3: NOT (SELF.name = 'dwell revolution') OR
        ((verify_required_rep_item      (SELF, 'dwell revolution')) AND
         (verify_count_measure_rep_item  (SELF, 'dwell revolution'))
        );
END_ENTITY;
(*)

```

Formal propositions:

**WR1:** The **name** of the **machining\_dwell\_time\_representation** shall be either 'dwell time' or 'dwell revolution'.

**WR2:** If the **name** of the **machining\_dwell\_time\_representation** is 'dwell time', the **items** set shall contain exactly one **representation\_item** with a **name** of 'dwell time', which shall be of type **measure\_representation\_item** and **time\_measure\_with\_unit**.

**WR3:** If the **name** of the **machining\_dwell\_time\_representation** is 'dwell revolution', the **items** set shall contain exactly one **representation\_item** with a **name** of 'dwell revolution', which shall be of type **measure\_representation\_item** with a **value\_component** of type **count\_measure**.

### 5.2.3.1.41 machining\_execution\_resource

A **machining\_execution\_resource** is a type of **action\_resource** that represents machine tool capability requirements for machining. See the ARM definition for Machine\_parameters in 4.2.192 for more information.

EXPRESS specification:

```

*)
ENTITY machining_execution_resource
  SUBTYPE OF (action_resource);

```

WHERE

```

WR1: ((verify_optional_resource_property      (SELF, 'feedrate')) AND
      (verify_rep_type_for_resource_property (SELF, 'feedrate',
        ['INTEGRATED_CNC_SCHEMA.MACHINING_FEED_SPEED_REPRESENTATION'])));

WR2: ((verify_optional_resource_property      (SELF, 'spindle')) AND
      (verify_rep_type_for_resource_property (SELF, 'spindle',
        ['INTEGRATED_CNC_SCHEMA.MACHINING_SPINDLE_SPEED_REPRESENTATION'])));

WR3: ((verify_optional_resource_property      (SELF, 'spindle power')) AND
      (verify_rep_item_for_resource_property (SELF, 'spindle power',
        ['INTEGRATED_CNC_SCHEMA.MEASURE_REPRESENTATION_ITEM'])));

WR4: ((verify_optional_resource_property      (SELF, 'spindle torque')) AND
      (verify_rep_item_for_resource_property (SELF, 'spindle torque',
        ['INTEGRATED_CNC_SCHEMA.MEASURE_REPRESENTATION_ITEM'])));

WR5: ((verify_optional_resource_property
      (SELF, 'number of control axis')) AND
      (verify_count_measure_resource_property
      (SELF, 'number of control axis')));

WR6: ((verify_optional_resource_property
      (SELF, 'number of simultaneous axis')) AND
      (verify_count_measure_resource_property
      (SELF, 'number of simultaneous axis')));

WR7: ((verify_optional_resource_property
      (SELF, 'positioning accuracy')) AND
      (verify_length_measure_resource_property
      (SELF, 'positioning accuracy')));

WR8: ((verify_optional_resource_property      (SELF, 'table indexing')) AND
      (verify_enumeration_resource_property (SELF, 'table indexing',
        ['required', 'not required'])));

WR9: ((verify_optional_resource_property
      (SELF, 'table length')) AND
      (verify_length_measure_resource_property
      (SELF, 'table length')) AND

      (verify_optional_resource_property
      (SELF, 'table width')) AND
      (verify_length_measure_resource_property
      (SELF, 'table width')));

WR10: ((verify_optional_resource_property (SELF, 'axis travel')) AND
      (0 = SIZEOF (QUERY (prop <* get_resource_property
        (SELF, 'axis travel') | NOT
        ((0 < SIZEOF (QUERY (prep <* USEDIN (prop,
          'INTEGRATED_CNC_SCHEMA.RESOURCE_PROPERTY_REPRESENTATION.PROPERTY') |
          (1 <= SIZEOF (QUERY ( it <* prep.representation.items |
            (SIZEOF([
              'INTEGRATED_CNC_SCHEMA.MEASURE_REPRESENTATION_ITEM',

```

```

        'INTEGRATED_CNC_SCHEMA.LENGTH_MEASURE_WITH_UNIT'] *
        TYPEOF(it) = 2)))
    )))
)))
);

WR11: ((verify_optional_resource_property
        (SELF, 'work volume length')) AND
        (verify_length_measure_resource_property
        (SELF, 'work volume length')) AND

        (verify_optional_resource_property
        (SELF, 'work volume width')) AND
        (verify_length_measure_resource_property
        (SELF, 'work volume width')) AND

        (verify_optional_resource_property
        (SELF, 'work volume height')) AND
        (verify_length_measure_resource_property
        (SELF, 'work volume height'))
);

WR12: (0 = SIZEOF (get_action_property (SELF, 'axis travel'))) OR
        ((0 = SIZEOF (get_action_property (SELF, 'work volume length'))) AND
        (0 = SIZEOF (get_action_property (SELF, 'work volume width'))) AND
        (0 = SIZEOF (get_action_property (SELF, 'work volume height'))));

END_ENTITY;
(*

```

#### Formal propositions:

**WR1:** The **machining\_execution\_resource** is the **resource** of at most one **resource\_property** with a **name** of 'feedrate', and the **representation** used to describe the **resource\_property** shall be of type **machining\_feed\_speed\_representation**.

**WR2:** The **machining\_execution\_resource** is the **resource** of at most one **resource\_property** with a **name** of 'spindle', and the **representation** used to describe the **resource\_property** shall be of type **machining\_spindle\_speed\_representation**.

**WR3:** The **machining\_execution\_resource** is the **resource** of at most one **resource\_property** with a **name** of 'spindle power', and the **representation** used to describe the **resource\_property** shall contain a **representation\_item** of type **measure\_representation\_item**.

**WR4:** The **machining\_execution\_resource** is the **resource** of at most one **resource\_property** with a **name** of 'spindle torque', and the **representation** used to describe the **resource\_property** shall contain a **representation\_item** of type **measure\_representation\_item**.

**WR5:** The **machining\_execution\_resource** is the **resource** of at most one **resource\_property** with a **name** of 'number of control axis', and the **representation** used to describe the **resource\_property** shall contain a **representation\_item** of type **measure\_representation\_item** in which the **value\_component** is of type **count\_measure**.

**WR6:** The **machining\_execution\_resource** is the **resource** of at most one **resource\_property** with a **name** of 'number of simultaneous axis', and the **representation** used to describe the **resource\_property** shall contain a **representation\_item** of type **measure\_representation\_item** in which the **value\_component** is of type **count\_measure**.

**WR7:** The **machining\_execution\_resource** is the **resource** of at most one **resource\_property** with a **name** of 'positioning accuracy', and the **representation** used to describe the **resource\_property** shall contain a **representation\_item** of type **measure\_representation\_item** and **length\_measure\_with\_unit**.

**WR8:** The **machining\_execution\_resource** is the **resource** of at most one **resource\_property** with a **name** of 'table indexing', and the **representation** used to describe the **resource\_property** shall contain a **representation\_item** of type **descriptive\_representation\_item** with a **description** of 'required' or 'not required'.

**WR9:** The **machining\_execution\_resource** shall satisfy the following conditions:

- the **machining\_execution\_resource** shall be the **resource** of at most one **resource\_property** with a **name** of 'table length', and the **representation** used to describe the **resource\_property** shall contain a **representation\_item** of type **measure\_representation\_item** and **length\_measure\_with\_unit**;
- the **machining\_execution\_resource** shall be the **resource** of at most one **resource\_property** with a **name** of 'table width', and the **representation** used to describe the **resource\_property** shall contain a **representation\_item** of type **measure\_representation\_item** and **length\_measure\_with\_unit**.

**WR10:** The **machining\_execution\_resource** is the **resource** of at most one **resource\_property** with a **name** of 'axis travel', and the **representation** used to describe the **resource\_property** shall contain at least one **representation\_item** of type **measure\_representation\_item** and **length\_measure\_with\_unit**.

**WR11:** The **machining\_execution\_resource** shall satisfy the following conditions:

- the **machining\_execution\_resource** shall be the **resource** of at most one **resource\_property** with a **name** of 'work volume length', and the **representation** used to describe the **resource\_property** shall contain a **representation\_item** of type **measure\_representation\_item** and **length\_measure\_with\_unit**;
- the **machining\_execution\_resource** shall be the **resource** of at most one **resource\_property** with a **name** of 'work volume width', and the **representation** used to describe the **resource\_property** shall contain a **representation\_item** of type **measure\_representation\_item** and **length\_measure\_with\_unit**;
- the **machining\_execution\_resource** shall be the **resource** of at most one **resource\_property** with a **name** of 'work volume height', and the **representation** used to describe the **resource\_property** shall contain a **representation\_item** of type **measure\_representation\_item** and **length\_measure\_with\_unit**.

**WR12:** The **machining\_execution\_resource** is the **resource** of no **resource\_property** with a **name** of 'axis travel', or else the **machining\_execution\_resource** is the **resource** of no **resource\_property** with a **name** of 'work volume length', 'work volume width', or 'work volume height'.

### 5.2.3.1.42 machining\_feature\_process

A **machining\_feature\_process** is a type of **machining\_process\_executable** that represents a set of steps in a machining process that result in a manufacturing feature. See the ARM definition for **Manufacturing\_feature** in ISO 14649-10 for more information.

#### EXPRESS specification:

```

*)
ENTITY machining_feature_process
  SUBTYPE OF (machining_process_executable);
  WHERE
  WR1: (1 = SIZEOF (QUERY (act < *
    USEDIN (SELF, 'INTEGRATED_CNC_SCHEMA.ACTION.CHOSEN_METHOD') |
    (act.name = 'machining')))) AND
    (0 = SIZEOF (QUERY (act < *
    USEDIN (SELF, 'INTEGRATED_CNC_SCHEMA.ACTION.CHOSEN_METHOD') |
    (act.name = 'machining') AND NOT
    ('INTEGRATED_CNC_SCHEMA.PROPERTY_PROCESS' IN TYPEOF (act))
    ))));
END_ENTITY;
(*

```

#### Formal propositions:

**WR1:** The **machining\_feature\_process** shall be the **chosen\_method** of exactly one **property\_process** with a **name** of 'machining'.

### 5.2.3.1.43 machining\_feature\_relationship

A **machining\_feature\_relationship** is a type of **action\_method\_relationship** that represents use of a feature as the manufacturing target of a workingstep. See the ARM definitions for **Workingstep** and **Turning\_workingstep** in ISO 14649-10 and ISO 14649-12 for more information.

#### EXPRESS specification:

```

*)
ENTITY machining_feature_relationship
  SUBTYPE OF (action_method_relationship);
END_ENTITY;
(*

```

### 5.2.3.1.44 machining\_feature\_sequence\_relationship

A **machining\_feature\_sequence\_relationship** is a type of **machining\_feature\_relationship** and **sequential\_method** that represents use of a feature as an element of a sequence of manufacturing tar-

gets of a workingstep. See the ARM definition for Turning\_workingstep in ISO 14649-12 for more information.

EXPRESS specification:

```
*)
ENTITY machining_feature_sequence_relationship
  SUBTYPE OF (machining_feature_relationship, sequential_method);
END_ENTITY;
(*
```

### 5.2.3.1.45 machining\_feed\_speed\_representation

A **machining\_feed\_speed\_representation** is a type of **representation** that represents the speed at which a tool is moved through material. The feed speed is described as one of the following:

- as a linear speed, as described by the ARM definitions for the Technology "feedrate" attribute in ISO 14649-10 and Feed\_velocity\_type in ISO 14649-12;
- as a length measure, which is the distance moved per tooth of a tool, as described by the ARM definition for the Milling\_technology "feedrate\_per\_tooth" attribute in ISO 14649-11;
- as a length measure, which is the distance moved per spindle revolution, as described by the ARM definitions for Turning\_technology "feedrate\_per\_revolution" and Feed\_per\_rev\_type in ISO 14649-12;
- as relative speed, expressed as a multiplier applied to a separate feed speed, as described by ARM definitions for the Drilling\_type\_strategy "reduced\_feed\_at\_start", "reduced\_feed\_at\_end", and Drilling\_type\_operation "feed\_on\_retract" attributes in ISO 14649-11, as well as definitions for the Turning\_machining\_strategy "variable\_feedrate" and Contour\_turning "variable\_stepover\_feed" attributes in ISO 14649-12.

EXPRESS specification:

```
*)
ENTITY machining_feed_speed_representation
  SUBTYPE OF (representation);
  WHERE
  WR1: (SELF.name IN ['feed speed', 'feed per revolution',
    'feed per tooth', 'relative speed']);

  WR2: NOT (SELF.name = 'feed speed') OR
    ((verify_required_rep_item (SELF, 'feed speed')) AND
    (verify_linear_speed_measure_rep_item (SELF, 'feed speed'))
    );

  WR3: NOT (SELF.name = 'feed per revolution') OR
    ((verify_required_rep_item (SELF, 'feed per revolution')) AND
    (0 = SIZEOF (QUERY ( it <* SELF.items |
    (it.name = 'feed per revolution') AND NOT (
    'INTEGRATED_CNC_SCHEMA.MEASURE_REPRESENTATION_ITEM' IN
```

```

        TYPEOF(it))))
    );

WR4: NOT (SELF.name = 'feed per tooth') OR
    ((verify_required_rep_item      (SELF, 'feed per tooth')) AND
    (0 = SIZEOF (QUERY ( it <* SELF.items |
    (it.name = 'feed per tooth') AND NOT (
    'INTEGRATED_CNC_SCHEMA.MEASURE_REPRESENTATION_ITEM' IN
    TYPEOF(it)))))
    );

WR5: NOT (SELF.name = 'relative speed') OR
    ((verify_required_rep_item      (SELF, 'relative speed')) AND
    (verify_ratio_measure_rep_item  (SELF, 'relative speed'))
    );
END_ENTITY;
(*

```

#### Formal propositions:

**WR1:** The **name** of the **machining\_feed\_speed\_representation** shall be either 'feed speed', 'feed per revolution', 'feed per tooth', or 'relative speed'.

**WR2:** If the **name** of the **machining\_feed\_speed\_representation** is 'feed speed', the **items** set shall contain exactly one **representation\_item** with a **name** of 'feed speed', which shall be of type **measure\_representation\_item** with a **value\_component** of type **numeric\_measure**.

**WR3:** If the **name** of the **machining\_feed\_speed\_representation** is 'feed per revolution', the **items** set shall contain exactly one **representation\_item** with a **name** of 'feed per revolution', which shall be of type **measure\_representation\_item**.

**WR4:** If the **name** of the **machining\_feed\_speed\_representation** is 'feed per tooth', the **items** set shall contain exactly one **representation\_item** with a **name** of 'feed per tooth', which shall be of type **measure\_representation\_item**.

**WR5:** If the **name** of the **machining\_feed\_speed\_representation** is 'relative speed', the **items** set shall contain exactly one **representation\_item** with a **name** of 'relative speed', which shall be of type **measure\_representation\_item** and **ratio\_measure\_with\_unit**.

### 5.2.3.1.46 machining\_final\_feature\_relationship

A **machining\_final\_feature\_relationship** is a type of **action\_method\_relationship** that represents a feature visible on the final form of the workpiece that a workingstep may not manufacture directly, but in some way contributes to the creation of. See 4.2.197.1 for more information.

#### EXPRESS specification:

```

*)
ENTITY machining_final_feature_relationship
    SUBTYPE OF (action_method_relationship);
END_ENTITY;
(*

```



### 5.2.3.1.47 machining\_functions

A **machining\_functions** instance is a type of **action\_method** that represents settings on the machine tool which is to execute a machining process. See the ARM definitions for **Machine\_functions** in ISO 14649-10, **Milling\_machine\_functions** in ISO 14649-11, and **Turning\_machine\_functions** in ISO 14649-12 for more information.

#### EXPRESS specification:

```

*)
ENTITY machining_functions
  SUBTYPE OF (action_method);
  WHERE
  WR1: NOT (SELF.description = 'milling') OR
        ((verify_required_action_property      (SELF, 'coolant')) AND
         (verify_enumeration_action_property    (SELF, 'coolant',
         ['coolant on', 'coolant off'])) AND

         (verify_optional_action_property      (SELF, 'coolant pressure')) AND
         (verify_pressure_measure_action_property
         (SELF, 'coolant pressure')) AND

         (verify_optional_action_property      (SELF, 'mist')) AND
         (verify_enumeration_action_property    (SELF, 'mist',
         ['mist on', 'mist off'])) AND

         (verify_optional_action_property      (SELF, 'through spindle coolant')) AND
         (verify_enumeration_action_property    (SELF, 'through spindle coolant',
         ['through spindle coolant on', 'through spindle coolant off'])) AND

         (verify_optional_action_property      (SELF, 'through spindle pressure')) AND
         (verify_pressure_measure_action_property
         (SELF, 'through spindle pressure')) AND

        -- axis constraints property must contain zero or more ranges
        (0 = SIZEOF (QUERY (prop <* get_action_property
        (SELF, 'axis constraints') | NOT
        ((0 < SIZEOF (QUERY (prep <* USEDIN (prop,
        'INTEGRATED_CNC_SCHEMA.ACTION_PROPERTY_REPRESENTATION.PROPERTY') |
        (0 <= SIZEOF (QUERY (it <* prep.representation.items |
        ('INTEGRATED_CNC_SCHEMA.VALUE_RANGE' in TYPEOF(it))))
        ))))))))
  );

  WR2: NOT (SELF.description = 'turning') OR
        ((verify_required_action_property      (SELF, 'coolant')) AND

```

```

    (verify_enumeration_action_property      (SELF, 'coolant',
      ['coolant on', 'coolant off'])) AND

    (verify_optional_action_property        (SELF, 'coolant type')) AND
    (verify_enumeration_action_property      (SELF, 'coolant type',
      ['flood', 'mist', 'through tool'])) AND

    (verify_optional_action_property        (SELF, 'coolant pressure')) AND
    (verify_pressure_measure_action_property (SELF, 'coolant pressure')) AND

    (verify_optional_action_property        (SELF, 'tail stock')) AND
    (verify_enumeration_action_property      (SELF, 'tail stock',
      ['tail stock used', 'tail stock not used'])) AND

    (verify_optional_action_property        (SELF, 'steady rest')) AND
    (verify_enumeration_action_property      (SELF, 'steady rest',
      ['steady rest used', 'steady rest not used'])) AND

    (verify_optional_action_property        (SELF, 'follow rest')) AND
    (verify_enumeration_action_property      (SELF, 'follow rest',
      ['follow rest used', 'follow rest not used']))
  );

WR3: NOT (SELF.description IN ['milling', 'turning']) OR
((verify_optional_action_property          (SELF, 'axis clamping')) AND
(0 = SIZEOF (QUERY (prop <*
  get_action_property (SELF, 'axis clamping') | NOT
  (0 < SIZEOF (QUERY (prep <* USEDIN (prop, 'INTEGRATED_CNC_SCHEMA.' +
    'ACTION_PROPERTY_REPRESENTATION.PROPERTY') |
  (1 = SIZEOF (QUERY (it <* prep.representation.items |
    (('INTEGRATED_CNC_SCHEMA.COMPOUND_REPRESENTATION_ITEM'
    IN TYPEOF(it)) AND
    ('INTEGRATED_CNC_SCHEMA.LIST_REPRESENTATION_ITEM'
    IN TYPEOF(it.item_element)) AND
    (0 = SIZEOF (QUERY (ie <* it.item_element | NOT
    ('INTEGRATED_CNC_SCHEMA.DESRIPTIVE_REPRESENTATION_ITEM'
    IN TYPEOF(ie)) )))
  ))))
  ))) AND

    (verify_optional_action_property        (SELF, 'chip removal')) AND
    (verify_enumeration_action_property      (SELF, 'chip removal',
      ['chip removal on', 'chip removal off'])) AND

    (verify_optional_action_property        (SELF, 'oriented spindle stop'))

AND

    (verify_rep_item_for_action_property     (SELF, 'oriented spindle stop',
      ['INTEGRATED_CNC_SCHEMA.DIRECTION'])) AND

    (verify_related_type_for_amr            (SELF,
      ['INTEGRATED_CNC_SCHEMA.MACHINING_PROCESS_MODEL_RELATIONSHIP'],

```

```

(['INTEGRATED_CNC_SCHEMA.MACHINING_PROCESS_MODEL'])) AND

(verify_optional_action_property (SELF, 'other functions')) AND
(0 = SIZEOF (QUERY (prop <* get_action_property
                    (SELF, 'other functions') | NOT
                    (0 < SIZEOF (QUERY (prep <* USEDIN (prop, 'INTEGRATED_CNC_SCHEMA.' +
                    'ACTION_PROPERTY_REPRESENTATION.PROPERTY') |
                    (1 = SIZEOF (QUERY (it <* prep.representation.items |
                    (('INTEGRATED_CNC_SCHEMA.COMPOUND_REPRESENTATION_ITEM'
                    IN TYPEOF(it)) AND
                    ('INTEGRATED_CNC_SCHEMA.SET_REPRESENTATION_ITEM'
                    IN TYPEOF(it.item_element))))
                    )))
                    )))
);
END_ENTITY;
>(*

```

#### Formal propositions:

**WR1:** If the **description** of the **machining\_functions** is 'milling', the **machining\_functions** shall satisfy the following conditions:

- the **machining\_functions** shall be the **definition** of exactly one **action\_property** with a **name** of 'coolant', and the **representation** used to describe the **action\_property** shall contain a **representation\_item** of type **descriptive\_representation\_item** with a **description** of 'coolant on' or 'coolant off';
- the **machining\_functions** shall be the **definition** of at most one **action\_property** with a **name** of 'coolant pressure', and the **representation** used to describe the **action\_property** shall contain a **representation\_item** that is of type **measure\_representation\_item** and have a **value\_component** of type **numeric\_measure**;
- the **machining\_functions** shall be the **definition** of at most one **action\_property** with a **name** of 'mist', and the **representation** used to describe the **action\_property** shall contain a **representation\_item** of type **descriptive\_representation\_item** with a **description** of 'mist on' or 'mist off';
- the **machining\_functions** shall be the **definition** of at most one **action\_property** with a **name** of 'through spindle coolant', and the **representation** used to describe the **action\_property** shall contain a **representation\_item** of type **descriptive\_representation\_item** with a **description** of 'through spindle coolant on' or 'through spindle coolant off';
- the **machining\_functions** shall be the **definition** of at most one **action\_property** with a **name** of 'through spindle pressure', and the **representation** used to describe the **action\_property** shall contain a **representation\_item** that is of type **measure\_representation\_item** and have a **value\_component** of type **numeric\_measure**.

— the **machining\_functions** shall be the **definition** of at most one **action\_property** with a **name** of 'axis constraints', and the **representation** used to describe the **action\_property** shall contain zero or more **representation\_items** that are of type **value\_range**.

**WR2:** If the **description** of the **machining\_functions** is 'turning', the **machining\_functions** shall satisfy the following conditions:

— the **machining\_functions** shall be the **definition** of exactly one **action\_property** with a **name** of 'coolant', and the **representation** used to describe the **action\_property** shall contain a **representation\_item** of type **descriptive\_representation\_item** with a **description** of 'coolant on' or 'coolant off';

— the **machining\_functions** shall be the **definition** of at most one **action\_property** with a **name** of 'coolant type', and the **representation** used to describe the **action\_property** shall contain a **representation\_item** of type **descriptive\_representation\_item** with a **description** of 'flood', 'mist', or 'through tool';

— the **machining\_functions** shall be the **definition** of at most one **action\_property** with a **name** of 'coolant pressure', and the **representation** used to describe the **action\_property** shall contain a **representation\_item** that is of type **measure\_representation\_item** and have a **value\_component** of type **numeric\_measure**;

— the **machining\_functions** shall be the **definition** of at most one **action\_property** with a **name** of 'tail stock', and the **representation** used to describe the **action\_property** shall contain a **representation\_item** of type **descriptive\_representation\_item** with a **description** of 'tail stock used' or 'tail stock not used';

— the **machining\_functions** shall be the **definition** of at most one **action\_property** with a **name** of 'steady rest', and the **representation** used to describe the **action\_property** shall contain a **representation\_item** of type **descriptive\_representation\_item** with a **description** of 'steady rest used' or 'steady rest not used';

— the **machining\_functions** shall be the **definition** of at most one **action\_property** with a **name** of 'follow rest', and the **representation** used to describe the **action\_property** shall contain a **representation\_item** of type **descriptive\_representation\_item** with a **description** of 'follow rest used' or 'follow rest not used'.

**WR3:** If the **description** of the **machining\_functions** is either 'milling' or 'turning', the **machining\_functions** shall satisfy the following conditions:

— the **machining\_functions** shall be the **definition** of at most one **action\_property** with a **name** of 'axis clamping', and the **representation** used to describe the **action\_property** shall contain exactly one **compound\_representation\_item**, in which the **item\_element** is of type **list\_representation\_item** and contains only instances of type **descriptive\_representation\_item**;

— the **machining\_functions** shall be the **definition** of at most one **action\_property** with a **name** of 'chip removal', and the **representation** used to describe the **action\_property** shall contain a **representation\_item** of type **descriptive\_representation\_item** with a **description** of 'chip removal on' or 'chip removal off';

- the **machining\_functions** shall be the **definition** of at most one **action\_property** with a **name** of 'oriented spindle stop', and the **representation** used to describe the **action\_property** shall contain a **representation\_item** of type **direction**;
- the **machining\_functions** shall be the **relating\_method** of zero or more **machining\_process\_model\_relationship**, in which **related\_method** shall be of type **machining\_process\_model**;
- the **machining\_functions** shall be the **definition** of at most one **action\_property** with a **name** of 'other functions', and the **representation** used to describe the **action\_property** shall contain exactly one **compound\_representation\_item**, in which the **item\_element** is of type **set\_representation\_item**.

Informal propositions:

**IP1:** All **machining\_process\_model\_relationship** instances which refer to the same **machining\_functions** through **relating\_method** shall have unique **sequence\_position** values.

### 5.2.3.1.48 machining\_functions\_relationship

A **machining\_functions\_relationship** is a type of **action\_method\_relationship** that represents use of a Machine\_functions description in some context. See the ARM definitions for Operation, Toolpath and their subtypes in ISO 14649-10, ISO 14649-11 and ISO 14649-12 for more information.

EXPRESS specification:

```
*)
ENTITY machining_functions_relationship
  SUBTYPE OF (action_method_relationship);
END_ENTITY;
(*
```

### 5.2.3.1.49 machining\_nc\_function

A **machining\_nc\_function** is a type of **machining\_process\_executable** that represents a step in a machining process. See the ARM definitions for NC\_function and subtypes in ISO 14649-10 and ISO 14649-11 for more information.

EXPRESS specification:

```
*)
ENTITY machining_nc_function
  SUBTYPE OF (machining_process_executable);
  WHERE
  WR1: (SELF.description IN ['display message',
    'optional stop', 'program stop', 'set mark', 'wait for mark',
    'exchange pallet', 'index pallet', 'load tool', 'unload tool',
    'legacy function']);

  WR2: NOT (SELF.description = 'display message') OR
    ((verify_required_action_property (SELF, 'message text')) AND
```

```

        (verify_descriptive_action_property      (SELF, 'message text')));

WR3: NOT (SELF.description = 'wait for mark') OR
      ((verify_required_action_property        (SELF, 'channel')));

WR4: NOT (SELF.description = 'index pallet') OR
      ((verify_required_action_property        (SELF, 'pallet index')) AND
       (verify_count_measure_action_property   (SELF, 'pallet index')));

WR5: NOT (SELF.description = 'index table') OR
      ((verify_required_action_property        (SELF, 'table index')) AND
       (verify_count_measure_action_property   (SELF, 'table index')));

WR6: NOT (SELF.description = 'load tool') OR
      (1 = SIZEOF (QUERY (mt <*
        USEDIN (SELF, 'INTEGRATED_CNC_SCHEMA.ACTION_RESOURCE.USAGE') |
        ('INTEGRATED_CNC_SCHEMA.MACHINING_TOOL' in TYPEOF(mt))));

WR7: NOT (SELF.description = 'unload tool') OR
      (1 >= SIZEOF (QUERY (mt <*
        USEDIN (SELF, 'INTEGRATED_CNC_SCHEMA.ACTION_RESOURCE.USAGE') |
        ('INTEGRATED_CNC_SCHEMA.MACHINING_TOOL' in TYPEOF(mt))));

WR8: NOT (SELF.description = 'legacy function') OR
      ((verify_required_action_property        (SELF, 'function text')) AND
       (verify_descriptive_action_property     (SELF, 'function text')));
END_ENTITY;
(*

```

### Formal propositions:

**WR1:** The **description** of the **machining\_nc\_function** shall be either 'display message', 'optional stop', 'program stop', 'set mark', 'wait for mark', 'exchange pallet', 'index pallet', 'index table', 'load tool', 'unload tool', or 'legacy function'.

**WR2:** If the **description** of the **machining\_nc\_function** is 'display message', the **machining\_nc\_function** shall be the **definition** of exactly one **action\_property** with a **name** of 'message text', and the **representation** used to describe the **action\_property** shall contain a **representation\_item** of type **descriptive\_representation\_item**.

**WR3:** If the **description** of the **machining\_nc\_function** is 'wait for mark', the **machining\_nc\_function** shall be the **definition** of exactly one **action\_property** with a **name** of 'channel'.

**WR4:** If the **description** of the **machining\_nc\_function** is 'index pallet', the **machining\_nc\_function** shall be the **definition** of exactly one **action\_property** with a **name** of 'pallet index', and the **representation** used to describe the **action\_property** shall contain a **representation\_item** of type **measure\_representation\_item** in which the **value\_component** is of type **count\_measure**.

**WR5:** If the **description** of the **machining\_nc\_function** is 'index table', the **machining\_nc\_function** shall be the **definition** of exactly one **action\_property** with a **name** of 'table index', and the **representation** used to describe the **action\_property** shall contain a **representation\_item** of type **measure\_representation\_item** in which the **value\_component** is of type **count\_measure**.

**WR6:** If the **description** of the **machining\_nc\_function** is 'load tool', the **machining\_nc\_function** shall appear in the **usage** set of exactly one **machining\_tool**.

**WR7:** If the **description** of the **machining\_nc\_function** is 'unload tool', the **machining\_nc\_function** shall appear in the **usage** set of at most one **machining\_tool**.

**WR8:** If the **description** of the **machining\_nc\_function** is 'legacy function', the **machining\_nc\_function** shall be the **definition** of exactly one **action\_property** with a **name** of 'function text', and the **representation** used to describe the **action\_property** shall contain a **representation\_item** of type **descriptive\_representation\_item**.

### 5.2.3.1.50 machining\_offset\_vector\_representation

A **machining\_offset\_vector\_representation** is a type of **representation** that identifies NC variables that will hold the translation and rotation of a machining workpiece. See the ARM definitions for **Offset\_vector** and **NC\_variable** in ISO 14649-10 for more information.

#### EXPRESS specification:

```

*)
ENTITY machining_offset_vector_representation
  SUBTYPE OF (representation);
  WHERE
  WR1: (1 = SIZEOF (QUERY ( it <* SELF.items | (it.name = 'translate')))) AND
        (0 = SIZEOF (QUERY ( it <* SELF.items | (it.name = 'translate') AND NOT
          (('INTEGRATED_CNC_SCHEMA.COMPOUND_REPRESENTATION_ITEM'
            IN TYPEOF(it)) AND
            ('INTEGRATED_CNC_SCHEMA.LIST_REPRESENTATION_ITEM'
            IN TYPEOF(it.item_element)) AND
            (SIZEOF(it.item_element) = 3) AND
            (0 = SIZEOF (QUERY (ie <* it.item_element | NOT
              (('INTEGRATED_CNC_SCHEMA.EXPRESSION_REPRESENTATION_ITEM'
                IN TYPEOF(ie)) AND
                ('INTEGRATED_CNC_SCHEMA.NUMERIC_VARIABLE' IN TYPEOF(ie))))))
          )
        )))
  WR2: (1 >= SIZEOF (QUERY ( it <* SELF.items | (it.name = 'rotate')))) AND
        (0 = SIZEOF (QUERY ( it <* SELF.items | (it.name = 'rotate') AND NOT
          (('INTEGRATED_CNC_SCHEMA.COMPOUND_REPRESENTATION_ITEM' IN TYPEOF(it))
          AND
          ('INTEGRATED_CNC_SCHEMA.LIST_REPRESENTATION_ITEM'
            IN TYPEOF(it.item_element)) AND
            (SIZEOF(it.item_element) = 3) AND
            (0 = SIZEOF (QUERY (ie <* it.item_element | NOT
              (('INTEGRATED_CNC_SCHEMA.EXPRESSION_REPRESENTATION_ITEM' IN
                TYPEOF(ie)) AND
                ('INTEGRATED_CNC_SCHEMA.NUMERIC_VARIABLE' IN TYPEOF(ie))))))
          )
        )))
END_ENTITY;
(*

```

Formal propositions:

**WR1:** The **items** set shall contain exactly one **representation\_item** with a **name** of 'translate', which shall be of type **compound\_representation\_item** with a **item\_element** of type **list\_representation\_item**. This list shall contain exactly three members, and all members shall be of type **expression\_representation\_item** and **numeric\_variable**.

**WR2:** The **items** set shall contain at most one **representation\_item** with a **name** of 'rotate', which shall be of type **compound\_representation\_item** with a **item\_element** of type **list\_representation\_item**. This list shall contain exactly three members, and all members shall be of type **expression\_representation\_item** and **numeric\_variable**.

### 5.2.3.1.51 machining\_operation

A **machining\_operation** is a type of **action\_method** that represents the manufacturing details of a step of a machining process. See the ARM definitions for Operation and subtypes in ISO 14649-10 and ISO 14649-11 for more information.

EXPRESS specification:

\*)

```

ENTITY machining_operation
  SUBTYPE OF (action_method);
  WHERE
    WR1: ((verify_related_type_for_amr      (SELF,
      ['INTEGRATED_CNC_SCHEMA.MACHINING_TOOLPATH_SEQUENCE_RELATIONSHIP'],
      ['INTEGRATED_CNC_SCHEMA.MACHINING_TOOLPATH']))
    );

    WR2: (verify_optional_action_property  (SELF, 'tool direction')) AND
    (verify_rep_type_for_action_property  (SELF, 'tool direction',
      ['INTEGRATED_CNC_SCHEMA.MACHINING_TOOL_DIRECTION_REPRESENTATION']));

    WR3: ('INTEGRATED_CNC_SCHEMA.MACHINING_RAPID_MOVEMENT' IN TYPEOF(SELF)) OR
    ('INTEGRATED_CNC_SCHEMA.MACHINING_TOUCH_PROBING' IN TYPEOF(SELF)) OR
    ((verify_optional_action_property      (SELF, 'retract plane')) AND
    (verify_length_measure_action_property (SELF, 'retract plane')) AND

    (verify_optional_action_property      (SELF, 'cut start point')) AND
    (verify_rep_item_for_action_property  (SELF, 'cut start point',
      ['INTEGRATED_CNC_SCHEMA.CARTESIAN_POINT'])) AND

    (1 = SIZEOF (QUERY (mt < *
      USEDIN (SELF, 'INTEGRATED_CNC_SCHEMA.ACTION_RESOURCE.USAGE') |
      ('INTEGRATED_CNC_SCHEMA.MACHINING_TOOL' in TYPEOF(mt)))))) AND

    (verify_required_relatng_amr (SELF,
      ['INTEGRATED_CNC_SCHEMA.MACHINING_TECHNOLOGY_RELATIONSHIP'])) AND
    (verify_related_type_for_amr  (SELF,
      ['INTEGRATED_CNC_SCHEMA.MACHINING_TECHNOLOGY_RELATIONSHIP'],
      ['INTEGRATED_CNC_SCHEMA.MACHINING_TECHNOLOGY'])) AND

```



```

        (verify_required_relating_amr (SELF,
          ['INTEGRATED_CNC_SCHEMA.MACHINING_FUNCTIONS_RELATIONSHIP'])) AND
        (verify_related_type_for_amr (SELF,
          ['INTEGRATED_CNC_SCHEMA.MACHINING_FUNCTIONS_RELATIONSHIP'],
          ['INTEGRATED_CNC_SCHEMA.MACHINING_FUNCTIONS']))
      );
END_ENTITY;
(*

```

#### Formal propositions:

**WR1:** The **machining\_operation** shall be the **relating\_method** of zero or more instances of **machining\_toolpath\_sequence\_relationship**, in which the **related\_method** shall be of type **machining\_toolpath**.

**WR2:** The **machining\_operation** shall be the **definition** of at most one **action\_property** with a **name** of 'tool direction', and the **representation** used to describe the **action\_property** shall be of type **machining\_tool\_direction\_representation**.

**WR3:** If the **machining\_operation** is not also a instance of either **machining\_rapid\_movement** or **machining\_touch\_probing**, the **machining\_operation** shall satisfy the following conditions:

- the **machining\_operation** shall be the **definition** of at most one **action\_property** with a **name** of 'retract plane', and the **representation** used to describe the **action\_property** shall contain a **representation\_item** of type **measure\_representation\_item** and **length\_measure\_with\_unit**;
- the **machining\_operation** shall be the **definition** of at most one **action\_property** with a **name** of 'cut start point', and the **representation** used to describe the **action\_property** shall contain a **representation\_item** of type **cartesian\_point**;
- the **machining\_operation** shall appear in the **usage** set of exactly one **machining\_tool**;
- the **machining\_operation** shall be the **relating\_method** of exactly one **machining\_technology\_relationship**, in which the **related\_method** shall be of type **machining\_technology**;
- the **machining\_operation** shall be the **relating\_method** of exactly one **machining\_functions\_relationship**, in which the **related\_method** shall be of type **machining\_functions**.

#### Informal propositions:

**IP1:** All **machining\_toolpath\_sequence\_relationship** instances which refer to the same **machining\_operation** through **relating\_method** shall have unique **sequence\_position** values.

### 5.2.3.1.52 machining\_operation\_relationship

A **machining\_operation\_relationship** is a type of **action\_method\_relationship** that represents use of an Operation to describe the action performed by a workingstep. See the ARM definitions for Workingstep and Turning\_workingstep in ISO 14649-10 and ISO 14649-12 for more information.

EXPRESS specification:

```
*)
ENTITY machining_operation_relationship
  SUBTYPE OF (action_method_relationship);
END_ENTITY;
(*
```

### 5.2.3.1.53 machining\_operator\_instruction

A **machining\_operator\_instruction** is a type of **action\_method\_with\_associated\_documents** that represents instructions to the human operator of a machining process. See the ARM definition for **Setup\_instruction** in ISO 14649-10 for more information.

EXPRESS specification:

```
*)
ENTITY machining_operator_instruction
  SUBTYPE OF (action_method_with_associated_documents);
  WHERE
    WR1: EXISTS (self.description) OR (0 < SIZEOF(self.documents));
END_ENTITY;
(*
```

Formal propositions:

**WR1:** Either the **description** of the **machining\_operator\_instruction** shall have a value, or the **documents** attribute shall contain at least one element.

NOTE This corresponds to local constraint **WR1** on the ARM entity **Setup\_instruction** in ISO 14649-10.

### 5.2.3.1.54 machining\_operator\_instruction\_relationship

A **machining\_operator\_instruction\_relationship** is a type of **sequential\_method** that represents use of a **Setup\_instruction** as an element of a sequence of instructions in a **Workpiece\_setup**. See the ARM definitions for **Workpiece\_setup** in ISO 14649-10 for more information.

EXPRESS specification:

```
*)
ENTITY machining_operator_instruction_relationship
  SUBTYPE OF (sequential_method);
END_ENTITY;
(*
```

### 5.2.3.1.55 machining\_process\_body\_relationship

A **machining\_process\_body\_relationship** is a type of **action\_method\_relationship** that represents use of an Executable as an element in the control flow described by another Executable. See the ARM definitions for the Executable subtypes in ISO 14649-10 for more information.

EXPRESS specification:

```

*)
ENTITY machining_process_body_relationship
  SUBTYPE OF (action_method_relationship);
END_ENTITY;
(*

```

**5.2.3.1.56 machining\_process\_branch\_relationship**

A **machining\_process\_branch\_relationship** is a type of **machining\_process\_body\_relationship** that represents use of an Executable as an element in the branching control flow described by another Executable. See the ARM definitions for *If\_statement*, *Selective*, and other Executable subtypes in ISO 14649-10 for more information.

EXPRESS specification:

```

*)
ENTITY machining_process_branch_relationship
  SUBTYPE OF (machining_process_body_relationship);
END_ENTITY;
(*

```

**5.2.3.1.57 machining\_process\_concurrent\_relationship**

A **machining\_process\_branch\_relationship** is a type of **machining\_process\_body\_relationship** and **concurrent\_action\_method** that represents use of an Executable as one of possibly several simultaneous elements in the control flow described by another Executable. See the ARM definitions for *Parallel* and other Executable subtypes in ISO 14649-10 for more information.

EXPRESS specification:

```

*)
ENTITY machining_process_concurrent_relationship
  SUBTYPE OF (machining_process_body_relationship, concurrent_action_method);
END_ENTITY;
(*

```

**5.2.3.1.58 machining\_process\_executable**

A **machining\_process\_executable** is a type of **action\_method** that represents an executable step in a machining process. See the ARM definitions for Executable and subtypes in ISO 14649-10 for more information

EXPRESS specification:

```

*)
ENTITY machining_process_executable
  SUBTYPE OF (action_method);
  WHERE

```

```

WR1: NOT (0 = SIZEOF (TYPEOF (SELF) *
    ['INTEGRATED_CNC_SCHEMA.MACHINING_FEATURE_PROCESS',
     'INTEGRATED_CNC_SCHEMA.MACHINING_NC_FUNCTION',
     'INTEGRATED_CNC_SCHEMA.MACHINING_RAPID_MOVEMENT',
     'INTEGRATED_CNC_SCHEMA.MACHINING_TOUCH_PROBING',
     'INTEGRATED_CNC_SCHEMA.MACHINING_WORKINGSTEP',
     'INTEGRATED_CNC_SCHEMA.MACHINING_WORKPLAN']
)) OR
(SELF.description IN ['assignment', 'if statement',
    'non-sequential', 'parallel', 'selective',
    'while statement', 'setup instructions']);

WR2: NOT (SELF.description = 'assignment') OR
((verify_required_action_property      (SELF, 'lvalue')) AND
 (verify_rep_item_for_action_property  (SELF, 'lvalue',
    ['INTEGRATED_CNC_SCHEMA.EXPRESSION_REPRESENTATION_ITEM',
     'INTEGRATED_CNC_SCHEMA.NUMERIC_VARIABLE'])) AND

 (verify_required_action_property      (SELF, 'rvalue')) AND
 (verify_rep_item_for_action_property  (SELF, 'rvalue',
    ['INTEGRATED_CNC_SCHEMA.EXPRESSION_REPRESENTATION_ITEM'])));

WR3: NOT (SELF.description = 'if statement') OR
((verify_required_action_property      (SELF, 'condition')) AND
 (verify_rep_item_for_action_property  (SELF, 'condition',
    ['INTEGRATED_CNC_SCHEMA.EXPRESSION_REPRESENTATION_ITEM',
     'INTEGRATED_CNC_SCHEMA.BOOLEAN_EXPRESSION'])) AND

 (verify_required_relatng_amr_with_name (SELF, 'true branch',
    ['INTEGRATED_CNC_SCHEMA.MACHINING_PROCESS_BRANCH_RELATIONSHIP'])) AND
 (verify_related_type_for_amr_with_name (SELF, 'true branch',
    ['INTEGRATED_CNC_SCHEMA.MACHINING_PROCESS_BRANCH_RELATIONSHIP'],
    ['INTEGRATED_CNC_SCHEMA.MACHINING_PROCESS_EXECUTABLE'])) AND

 (verify_optional_relatng_amr_with_name (SELF, 'false branch',
    ['INTEGRATED_CNC_SCHEMA.MACHINING_PROCESS_BRANCH_RELATIONSHIP'])) AND
 (verify_related_type_for_amr_with_name (SELF, 'false branch',
    ['INTEGRATED_CNC_SCHEMA.MACHINING_PROCESS_BRANCH_RELATIONSHIP'],
    ['INTEGRATED_CNC_SCHEMA.MACHINING_PROCESS_EXECUTABLE']))
);

WR4: NOT (SELF.description = 'while statement') OR
((verify_required_action_property      (SELF, 'condition')) AND
 (verify_rep_item_for_action_property  (SELF, 'condition',
    ['INTEGRATED_CNC_SCHEMA.EXPRESSION_REPRESENTATION_ITEM',
     'INTEGRATED_CNC_SCHEMA.BOOLEAN_EXPRESSION'])) AND

 (verify_required_relatng_amr      (SELF,
    ['INTEGRATED_CNC_SCHEMA.MACHINING_PROCESS_BODY_RELATIONSHIP'])) AND
 (verify_related_type_for_amr      (SELF,
    ['INTEGRATED_CNC_SCHEMA.MACHINING_PROCESS_BODY_RELATIONSHIP'],
    ['INTEGRATED_CNC_SCHEMA.MACHINING_PROCESS_EXECUTABLE']))
);

```

```

WR5: NOT (SELF.description = 'parallel') OR
      ((2 <= get_count_of_relating_amr (SELF,
        ['INTEGRATED_CNC_SCHEMA.MACHINING_PROCESS_CONCURRENT_RELATIONSHIP']))
      AND
      (verify_related_type_for_amr (SELF,
        ['INTEGRATED_CNC_SCHEMA.MACHINING_PROCESS_CONCURRENT_RELATIONSHIP'],
        ['INTEGRATED_CNC_SCHEMA.MACHINING_PROCESS_EXECUTABLE'])))
      );

WR6: NOT (SELF.description = 'non-sequential') OR
      ((2 <= get_count_of_relating_amr (SELF,
        ['INTEGRATED_CNC_SCHEMA.MACHINING_PROCESS_BODY_RELATIONSHIP'])) AND
      (verify_related_type_for_amr (SELF,
        ['INTEGRATED_CNC_SCHEMA.MACHINING_PROCESS_BODY_RELATIONSHIP'],
        ['INTEGRATED_CNC_SCHEMA.MACHINING_PROCESS_EXECUTABLE'])))
      );

WR7: NOT (SELF.description = 'selective') OR
      ((2 <= get_count_of_relating_amr (SELF,
        ['INTEGRATED_CNC_SCHEMA.MACHINING_PROCESS_BRANCH_RELATIONSHIP'])) AND
      (verify_related_type_for_amr (SELF,
        ['INTEGRATED_CNC_SCHEMA.MACHINING_PROCESS_BRANCH_RELATIONSHIP'],
        ['INTEGRATED_CNC_SCHEMA.MACHINING_PROCESS_EXECUTABLE'])))
      );

WR8: NOT (SELF.description = 'setup instructions') OR
      ((verify_related_type_for_amr (SELF,
        ['INTEGRATED_CNC_SCHEMA.MACHINING_OPERATOR_INSTRUCTION_RELATIONSHIP'],
        ['INTEGRATED_CNC_SCHEMA.MACHINING_OPERATOR_INSTRUCTION'])))
      );
END_ENTITY;
(*

```

### Formal propositions:

**WR1:** If the **machining\_process\_executable** is exactly of type **machining\_process\_executable** and not an instance of any of the subtypes **machining\_workingstep**, **machining\_workplan**, **machining\_feature\_process**, **machining\_rapid\_movement**, **machining\_touch\_probing**, or **machining\_nc\_function**, the **description** of the **machining\_process\_executable** shall be either 'assignment', 'if statement', 'non-sequential', 'parallel', 'selective', 'while statement', or 'setup instructions'.

**WR2:** If the **description** of the **machining\_process\_executable** is 'assignment', the **machining\_process\_executable** shall satisfy the following conditions:

- the **machining\_process\_executable** shall be the **definition** of exactly one **action\_property** with a **name** of 'lvalue', and the **representation** used to describe the **action\_property** shall contain a **representation\_item** of type **expression\_representation\_item** and **numeric\_variable**;
- the **machining\_process\_executable** shall be the **definition** of exactly one **action\_property** with a **name** of 'rvalue', and the **representation** used to describe the **action\_property** shall contain a **representation\_item** of type **expression\_representation\_item**.

**WR3:** If the **description** of the **machining\_process\_executable** is 'if statement', the **machining\_process\_executable** shall satisfy the following conditions:

- the **machining\_process\_executable** shall be the **definition** of exactly one **action\_property** with a **name** of 'condition', and the **representation** used to describe the **action\_property** shall contain a **representation\_item** of type **expression\_representation\_item** and **boolean\_expression**;
- the **machining\_process\_executable** shall be the **relating\_method** of exactly one **machining\_process\_branch\_relationship** with a **name** of 'true branch', in which the **related\_method** is of type **machining\_process\_executable**;
- the **machining\_process\_executable** shall be the **relating\_method** of at most one **machining\_process\_branch\_relationship** with a **name** of 'false branch', in which the **related\_method** is of type **machining\_process\_executable**.

**WR4:** If the **description** of the **machining\_process\_executable** is 'while statement', the **machining\_process\_executable** shall satisfy the following conditions:

- the **machining\_process\_executable** shall be the **definition** of exactly one **action\_property** with a **name** of 'condition', and the **representation** used to describe the **action\_property** shall contain a **representation\_item** of type **expression\_representation\_item** and **boolean\_expression**;
- the **machining\_process\_executable** shall be the **relating\_method** of exactly one **machining\_process\_body\_relationship**, in which the **related\_method** is of type **machining\_process\_executable**.

**WR5:** If the **description** of the **machining\_process\_executable** is 'parallel', the **machining\_process\_executable** shall be the **relating\_method** of at least two instances of **machining\_process\_concurrent\_relationship**, in which the **related\_method** is of type **machining\_process\_executable**.

**WR6:** If the **description** of the **machining\_process\_executable** is 'non-sequential', the **machining\_process\_executable** shall be the **relating\_method** of at least two instances of **machining\_process\_body\_relationship**, in which the **related** is of type **machining\_process\_executable**.

**WR7:** If the **description** of the **machining\_process\_executable** is 'selective', the **machining\_process\_executable** shall be the **relating\_method** of at least two instances of **machining\_process\_branch\_relationship**, in which the **related\_method** is of type **machining\_process\_executable**.

**WR8:** If the **description** of the **machining\_process\_executable** is 'setup instructions', the **machining\_process\_executable** shall be the **relating\_method** of zero or more instances of **machining\_operator\_instruction\_relationship**, in which the **related\_method** is of type **machining\_operator\_instruction**.

Informal propositions:

**IP1:** The **name** of a **machining\_process\_executable** shall be unique within the machining process.

### 5.2.3.1.59 machining\_process\_model

A **machining\_process\_model** is a type of **action\_method** that represents process control settings on the machine tool which is to execute a machining process. See the ARM definition for **Process\_model** in ISO 14649-11 for more information.

#### EXPRESS specification:

```
*)
ENTITY machining_process_model
  SUBTYPE OF (action_method);
  WHERE
    WR1: (verify_required_action_property (SELF, 'initialization data')) AND
          (verify_descriptive_action_property (SELF, 'initialization data'));
END_ENTITY;
(*
```

#### Formal propositions:

**WR1:** The **machining\_process\_model** shall be the **definition** of exactly one **action\_property** with a **name** of 'initialization data', and the **representation** used to describe the **action\_property** shall contain a **representation\_item** of type **descriptive\_representation\_item**.

### 5.2.3.1.60 machining\_process\_model\_relationship

A **machining\_process\_model\_relationship** is a type of **sequential\_method** that represents use of a **Process\_model** as an element of a sequence of models in a **Machine\_functions** description. See the ARM definitions for the **Machine\_functions** subtypes in ISO 14649-11 and ISO 14649-12 for more information.

#### EXPRESS specification:

```
*)
ENTITY machining_process_model_relationship
  SUBTYPE OF (sequential_method);
END_ENTITY;
(*
```

### 5.2.3.1.61 machining\_process\_sequence\_relationship

A **machining\_process\_sequence\_relationship** is a type of **machining\_process\_body\_relationship** and **sequential\_method** that represents use of an Executable as an element of a sequence in the control flow described by another Executable. See the ARM definitions for **Workplan** and other Executable subtypes in ISO 14649-10 for more information.

#### EXPRESS specification:

```
*)
ENTITY machining_process_sequence_relationship
  SUBTYPE OF (machining_process_body_relationship, sequential_method);
```

```
END_ENTITY;
(*
```

### 5.2.3.1.62 machining\_project

A **machining\_project** is a type of **product** that represents a Project. See the ARM definitions for Project in ISO 14649-10 for more information.

#### EXPRESS specification:

```
*)
ENTITY machining_project
    SUBTYPE OF (product);
    WHERE
    WR1: (0 = SIZEOF (QUERY (pdf <* USEDIN (SELF,
        'INTEGRATED_CNC_SCHEMA.' +
        'PRODUCT_DEFINITION_FORMATION.OF_PRODUCT') | NOT

        -- it has at most one associated owner.
        (1 >= SIZEOF (QUERY (poa <* USEDIN (pdf,
            'INTEGRATED_CNC_SCHEMA.' +
            'APPLIED_PERSON_AND_ORGANIZATION_ASSIGNMENT.ITEMS') |
            (poa.role.name = 'owner'))))
        )))

    WR2: (0 = SIZEOF (QUERY (pdf <* USEDIN (SELF,
        'INTEGRATED_CNC_SCHEMA.' +
        'PRODUCT_DEFINITION_FORMATION.OF_PRODUCT') | NOT

        -- it has at most one associated release date.
        (1 >= SIZEOF (QUERY (dta <* USEDIN (pdf,
            'INTEGRATED_CNC_SCHEMA.' +
            'APPLIED_DATE_AND_TIME_ASSIGNMENT.ITEMS') |
            (dta.role.name = 'release date'))))
        )))

    WR3: (0 = SIZEOF (QUERY (pdf <* USEDIN (SELF,
        'INTEGRATED_CNC_SCHEMA.' +
        'PRODUCT_DEFINITION_FORMATION.OF_PRODUCT') | NOT

        (0 = SIZEOF (QUERY (pd <* USEDIN (pdf,
            'INTEGRATED_CNC_SCHEMA.PRODUCT_DEFINITION.FORMATION') | NOT

            -- it has one associated workplan.
            (1 = SIZEOF (QUERY (ppa <* USEDIN (pd,
                'INTEGRATED_CNC_SCHEMA.' +
                'PROCESS_PRODUCT_ASSOCIATION.DEFINED_PRODUCT') |
                (ppa.process.name = 'machining') AND
                ('INTEGRATED_CNC_SCHEMA.MACHINING_WORKPLAN'
                 IN TYPEOF (ppa.process.chosen_method))))))
            )))
    )))
```



```

    ));
END_ENTITY;
(*

```

#### Formal propositions:

**WR1:** Each **product\_definition\_formation** that refers to the **machining\_project** as **of\_product**, shall itself appear in the **items** set of at most one **applied\_person\_and\_organization\_assignment** instance in which **role** refers to a **person\_and\_organization\_role** with a **name** of 'owner'.

**WR2:** Each **product\_definition\_formation** that refers to the **machining\_project** as **of\_product**, shall itself appear in the **items** set of at most one **applied\_date\_and\_time\_assignment** instance in which **role** refers to a **date\_and\_time\_role** with a **name** of 'release date'.

**WR3:** Each **product\_definition** that refers to a **product\_definition\_formation** that refers to the **machining\_project** as **of\_product**, shall itself appear as the **defined\_product** of exactly one **process\_product\_association** instance in which **process** shall have a **name** of 'machining' and a **chosen\_method** of type **machining\_workplan**.

### 5.2.3.1.63 machining\_project\_workpiece\_relationship

A **machining\_project\_workpiece\_relationship** is a type of **product\_definition\_relationship** that represents use of an Workpiece as an element of a Project. See the ARM definitions for Project in ISO 14649-10 for more information.

#### EXPRESS specification:

```

*)
ENTITY machining_project_workpiece_relationship
  SUBTYPE OF (product_definition_relationship);
END_ENTITY;
(*

```

### 5.2.3.1.64 machining\_rapid\_movement

A **machining\_rapid\_movement** is a type of **machining\_process\_executable** and **machining\_operation** that represents a rapid motion of the machine axes in a machining process. See the ARM definitions for Rapid\_movement and subtypes in ISO 14649-10 for more information.

#### EXPRESS specification:

```

*)
ENTITY machining_rapid_movement
  SUBTYPE OF (machining_process_executable, machining_operation);
  WHERE
  WR1: ((verify_required_action_property (SELF, 'security plane')) AND
        (verify_rep_item_for_action_property (SELF, 'security plane',
        ['INTEGRATED_CNC_SCHEMA.ELEMENTARY_SURFACE'])));
END_ENTITY;
(*

```

Formal propositions:

**WR1:** The **machining\_rapid\_movement** shall be the **definition** of exactly one **action\_property** with a **name** of 'security plane', and the **representation** used to describe the **action\_property** shall contain a **representation\_item** of type **elementary\_surface**.

### 5.2.3.1.65 machining\_setup

A **machining\_setup** is a type of **product** that represents a Setup. See the ARM definitions for Setup in ISO 14649-10 for more information.

EXPRESS specification:

```

*)
ENTITY machining_setup
  SUBTYPE OF (product);
  WHERE
  WR1: (0 = SIZEOF (QUERY (pdf <* USEDIN (SELF,
    'INTEGRATED_CNC_SCHEMA.' +
    'PRODUCT_DEFINITION_FORMATION.OF_PRODUCT') | NOT

    (0 = SIZEOF (QUERY (pd <* USEDIN (pdf,
    'INTEGRATED_CNC_SCHEMA.PRODUCT_DEFINITION.FORMATION') | NOT

    -- it has one associated security plane.
    (1 = SIZEOF (QUERY (prop <* USEDIN (pd,
    'INTEGRATED_CNC_SCHEMA.PROPERTY_DEFINITION.DEFINITION') |
    (prop.name = 'security plane'))))
    )))
  ));

END_ENTITY;
(*

```

Formal propositions:

**WR1:** Each **product\_definition** that refers to a **product\_definition\_formation** that refers to the **machining\_setup** shall be the **definition** of exactly one **property\_definition** with a **name** of 'security plane'.

### 5.2.3.1.66 machining\_setup\_workpiece\_relationship

A **machining\_setup\_workpiece\_relationship** is a type of **product\_definition\_relationship** that represents use of an Workpiece as an element of a Setup in a Workpiece\_setup. See the ARM definitions for Setup and Workpiece\_setup in ISO 14649-10 for more information.

EXPRESS specification:

```

*)
ENTITY machining_setup_workpiece_relationship
  SUBTYPE OF (product_definition_relationship);

```

```
END_ENTITY;
(*)
```

### 5.2.3.1.67 machining\_spindle\_speed\_representation

A **machining\_spindle\_speed\_representation** is a type of **representation** that represents the speed at which a machine tool spindle rotates. The spindle speed is described as one of the following:

- as a rotational speed, as described by the ARM definitions for the Milling\_technology "spindle" attribute in ISO 14649-11 and Const\_spindle\_speed in ISO 14649-12;
- as a linear speed measured at the contact point between tool and surface, as described by the ARM definition for Milling\_technology "cutspeed" attribute in ISO 14649-11 and Const\_cutting\_speed in ISO 14649-12;
- as relative speed, expressed as a multiplier applied to a separate spindle speed, as described by the ARM definitions for the Drilling\_type\_strategy "reduced\_cut\_at\_start" and "reduced\_feed\_at\_end" attributes in ISO 14649-11.

#### EXPRESS specification:

```
*)
ENTITY machining_spindle_speed_representation
  SUBTYPE OF (representation);
  WHERE
    WR1: (SELF.name IN ['spindle speed', 'cutting speed', 'relative speed']);

    WR2: NOT (SELF.name = 'spindle speed') OR
      ((verify_required_rep_item (SELF, 'rotational speed')) AND
       (verify_rotary_speed_measure_rep_item (SELF, 'rotational speed'))
      );

    WR3: NOT (SELF.name = 'cutting speed') OR
      ((verify_required_rep_item (SELF, 'surface speed')) AND
       (verify_linear_speed_measure_rep_item (SELF, 'surface speed')) AND

       (verify_optional_rep_item
        (SELF, 'maximum rotational speed')) AND
       (verify_rotary_speed_measure_rep_item
        (SELF, 'maximum rotational speed'))
      );

    WR4: NOT (SELF.name = 'relative speed') OR
      ((verify_required_rep_item (SELF, 'relative speed')) AND
       (verify_ratio_measure_rep_item (SELF, 'relative speed'))
      );
END_ENTITY;
(*)
```

Formal propositions:

**WR1:** The **name** of the **machining\_spindle\_speed\_representation** shall be either 'spindle speed', 'cutting speed', or 'relative speed'.

**WR2:** If the **name** of the **machining\_spindle\_speed\_representation** is 'spindle speed', the **items** set shall contain exactly one **representation\_item** with a **name** of 'rotational speed', which shall be of type **measure\_representation\_item** with a **value\_component** of type **numeric\_measure**.

**WR3:** If the **name** of the **machining\_spindle\_speed\_representation** is 'cutting speed', the **items** set shall contain the following items:

- exactly one **representation\_item** with a **name** of 'surface speed', which shall be type **measure\_representation\_item** with a **value\_component** of type **numeric\_measure**;
- at most one **representation\_item** with a **name** of 'maximum rotational speed', which shall be type **measure\_representation\_item** with a **value\_component** of type **numeric\_measure**.

**WR4:** If the **name** of the **machining\_spindle\_speed\_representation** is 'relative speed', the **items** set shall contain exactly one **representation\_item** with a **name** of 'relative speed', which shall be of type **measure\_representation\_item** and **ratio\_measure\_with\_unit**.

### 5.2.3.1.68 machining\_strategy

A **machining\_strategy** is a type of **action\_method** that represents a particular approach used to perform some aspect of a step in a machining process.

EXPRESS specification:

```
*)  
ENTITY machining_strategy  
    SUBTYPE OF (action_method);  
END_ENTITY;  
(*
```

### 5.2.3.1.69 machining\_strategy\_relationship

A **machining\_strategy\_relationship** is a type of **action\_method\_relationship** that represents use of a **Two5d\_milling\_strategy**, **Drilling\_type\_strategy**, **Freeform\_strategy**, **Turning\_machining\_strategy**, or **Approach\_retract\_strategy** description in some context. See the ARM definitions for the Operation subtypes in ISO 14649-11 and ISO 14649-12 for more information.

EXPRESS specification:

```
*)  
ENTITY machining_strategy_relationship  
    SUBTYPE OF (action_method_relationship);  
END_ENTITY;  
(*
```

### 5.2.3.1.70 machining\_technology

A **machining\_technology** is a type of **action\_method** that represents technological parameters that govern a portion of a machining process. See the ARM definitions for Technology in ISO 14649-10 Milling\_technology in ISO 14649-11, and Turning\_technology in ISO 14649-12 for more information.

#### EXPRESS specification:

```

*)
ENTITY machining_technology
  SUBTYPE OF (action_method);
  WHERE
  WR1: (verify_optional_action_property      (SELF, 'feedrate')) AND
        (verify_rep_type_for_action_property (SELF, 'feedrate',
          ['INTEGRATED_CNC_SCHEMA.MACHINING_FEED_SPEED_REPRESENTATION']));

  WR2: (verify_optional_action_property      (SELF, 'feedrate reference')) AND
        (verify_enumeration_action_property (SELF, 'feedrate reference',
          ['tool center point', 'cutter contact point']));

  WR3: NOT (SELF.description = 'milling') OR
        ((verify_optional_action_property      (SELF, 'spindle')) AND
         (verify_rep_type_for_action_property (SELF, 'spindle',
          ['INTEGRATED_CNC_SCHEMA.MACHINING_SPINDLE_SPEED_REPRESENTATION'])) AND

         (verify_optional_action_property
          (SELF, 'synchronize spindle with feed')) AND
         (verify_enumeration_action_property
          (SELF, 'synchronize spindle with feed',
          ['synchronized', 'not synchronized'])) AND

         (verify_optional_action_property
          (SELF, 'inhibit feedrate override')) AND
         (verify_enumeration_action_property
          (SELF, 'inhibit feedrate override',
          ['override allowed', 'override not allowed'])) AND

         (verify_optional_action_property
          (SELF, 'inhibit spindle override')) AND
         (verify_enumeration_action_property
          (SELF, 'inhibit spindle override',
          ['override allowed', 'override not allowed'])) AND

         (verify_optional_relating_amr      (SELF,
          ['INTEGRATED_CNC_SCHEMA.MACHINING_ADAPTIVE_CONTROL_RELATIONSHIP']));

  AND

        (verify_related_type_for_amr      (SELF,
          ['INTEGRATED_CNC_SCHEMA.MACHINING_ADAPTIVE_CONTROL_RELATIONSHIP'],
          ['INTEGRATED_CNC_SCHEMA.MACHINING_TECHNOLOGY']));

  );

  WR4: NOT (SELF.description = 'milling') OR
        ((verify_required_relating_amr      (SELF,

```

```

(['INTEGRATED_CNC_SCHEMA.MACHINING_ADAPTIVE_CONTROL_RELATIONSHIP'])) OR

(verify_required_action_property (SELF, 'spindle') AND
verify_rep_name_for_action_property (SELF, 'spindle',
['spindle speed', 'cutting speed']))
);

WR5: NOT (SELF.description = 'milling') OR
((verify_required_relatng_amr (SELF,
['INTEGRATED_CNC_SCHEMA.MACHINING_ADAPTIVE_CONTROL_RELATIONSHIP'])) OR

(verify_required_action_property (SELF, 'feedrate') AND
verify_rep_name_for_action_property (SELF, 'feedrate',
['feed speed', 'feed per tooth']))
);

WR6: NOT (SELF.description = 'turning') OR
((verify_optional_action_property (SELF, 'spindle')) AND
(verify_rep_type_for_action_property (SELF, 'spindle',
['INTEGRATED_CNC_SCHEMA.MACHINING_SPINDLE_SPEED_REPRESENTATION'])) AND
(verify_rep_name_for_action_property (SELF, 'spindle',
['spindle speed', 'cutting speed'])) AND

(verify_rep_name_for_action_property (SELF, 'feedrate',
['feed speed', 'feed per revolution'])) AND

(verify_optional_action_property
(SELF, 'synchronize spindle with z feed')) AND
(verify_enumeration_action_property
(SELF, 'synchronize spindle with z feed',
['synchronized', 'not synchronized'])) AND

(verify_optional_action_property
(SELF, 'inhibit feedrate override')) AND
(verify_enumeration_action_property
(SELF, 'inhibit feedrate override',
['override allowed', 'override not allowed'])) AND

(verify_optional_action_property
(SELF, 'inhibit spindle override')) AND
(verify_enumeration_action_property
(SELF, 'inhibit spindle override',
['override allowed', 'override not allowed'])) AND

(verify_optional_relatng_amr (SELF,
['INTEGRATED_CNC_SCHEMA.MACHINING_ADAPTIVE_CONTROL_RELATIONSHIP']))
AND
(verify_related_type_for_amr (SELF,
['INTEGRATED_CNC_SCHEMA.MACHINING_ADAPTIVE_CONTROL_RELATIONSHIP'],
['INTEGRATED_CNC_SCHEMA.MACHINING_TECHNOLOGY']))
);
END_ENTITY;
(*

```

Formal propositions:

**WR1:** The **machining\_technology** shall be the **definition** of at most one **action\_property** with a **name** of 'feedrate', and the **representation** used to describe the **action\_property** shall be of type **machining\_feed\_speed\_representation**.

**WR2:** The **machining\_technology** shall be the **definition** of at most one **action\_property** with a **name** of 'feedrate reference', and the **representation** used to describe the **action\_property** shall contain a **representation\_item** of type **descriptive\_representation\_item** with a **description** of 'tool center point' or 'cutter contact point'.

**WR3:** If the **description** of the **machining\_technology** is 'milling', the **machining\_technology** shall satisfy the following conditions:

- the **machining\_technology** shall be the **definition** of at most one **action\_property** with a **name** of 'spindle', and the **representation** used to describe the **action\_property** shall be of type **machining\_spindle\_speed\_representation**;
- the **machining\_technology** shall be the **definition** of at most one **action\_property** with a **name** of 'synchronize spindle with feed', and the **representation** used to describe the **action\_property** shall contain a **representation\_item** of type **descriptive\_representation\_item** with a **description** of 'synchronized' or 'not synchronized';
- the **machining\_technology** shall be the **definition** of at most one **action\_property** with a **name** of 'inhibit feedrate override', and the **representation** used to describe the **action\_property** shall contain a **representation\_item** of type **descriptive\_representation\_item** with a **description** of 'override allowed' or 'override not allowed';
- the **machining\_technology** shall be the **definition** of at most one **action\_property** with a **name** of 'inhibit spindle override', and the **representation** used to describe the **action\_property** shall contain a **representation\_item** of type **descriptive\_representation\_item** with a **description** of 'override allowed' or 'override not allowed';
- the **machining\_technology** shall be the **relating\_method** of at most one **machining\_adaptive\_control\_relationship**, in which the **related\_method** shall be of type **machining\_technology**.

**WR4:** If the **description** of the **machining\_technology** is 'milling', either the **machining\_technology** shall be the **relating\_method** of exactly one **machining\_adaptive\_control\_relationship**, or else the **machining\_technology** shall be the **definition** of exactly one **action\_property** with a **name** of 'spindle', and the **representation** used to describe the **action\_property** shall have a **description** of either 'spindle speed' or 'cutting speed'.

NOTE This corresponds to local constraint **WR1** on the ARM entity **Milling\_technology** in ISO 14649-11

**WR5:** If the **description** of the **machining\_technology** is 'milling', either the **machining\_technology** shall be the **relating\_method** of exactly one **machining\_adaptive\_control\_relationship**, or else the **machining\_technology** shall be the **definition** of exactly one **action\_property** with a **name** of 'feedrate', and the **representation** used to describe the **action\_property** shall have a **description** of either 'feed speed' or 'feed per tooth'.

NOTE This corresponds to local constraint **WR2** on the ARM entity `Milling_technology` in ISO 14649-11

**WR6:** If the **description** of the **machining\_technology** is 'turning', the **machining\_technology** shall satisfy the following conditions:

- the **machining\_technology** shall be the **definition** of at most one **action\_property** with a **name** of 'spindle', and the **representation** used to describe the **action\_property** shall be of type **machining\_spindle\_speed\_representation** with a **description** of either 'spindle speed' or 'cutting speed';
- if the **machining\_technology** is the **definition** of an **action\_property** with a **name** of 'feedrate', the **representation** used to describe the **action\_property** shall have a **description** of either 'feed speed' or 'feed per revolution';
- the **machining\_technology** shall be the **definition** of at most one **action\_property** with a **name** of 'synchronize spindle with z feed', and the **representation** used to describe the **action\_property** shall contain a **representation\_item** of type **descriptive\_representation\_item** with a **description** of 'synchronized' or 'not synchronized';
- the **machining\_technology** shall be the **definition** of at most one **action\_property** with a **name** of 'inhibit feedrate override', and the **representation** used to describe the **action\_property** shall contain a **representation\_item** of type **descriptive\_representation\_item** with a **description** of 'override allowed' or 'override not allowed';
- the **machining\_technology** shall be the **definition** of at most one **action\_property** with a **name** of 'inhibit spindle override', and the **representation** used to describe the **action\_property** shall contain a **representation\_item** of type **descriptive\_representation\_item** with a **description** of 'override allowed' or 'override not allowed';
- the **machining\_technology** shall be the **relating\_method** of at most one **machining\_adaptive\_control\_relationship**, in which the **related\_method** shall be of type **machining\_technology**.

### 5.2.3.1.71 machining\_technology\_relationship

A **machining\_technology\_relationship** is a type of **action\_method\_relationship** that represents use of a Technology description in some context. See the ARM definitions for Operation, Toolpath and their subtypes in ISO 14649-10, ISO 14649-11 and ISO 14649-12 for more information.

EXPRESS specification:

```
*)
ENTITY machining_technology_relationship
  SUBTYPE OF (action_method_relationship);
END_ENTITY;
(*
```



### 5.2.3.1.72 machining\_tool

A **machining\_tool** is a type of **action\_resource** that represents tool requirements for machining. See the ARM definitions for **Machining\_tool** in ISO 14649-10, **Milling\_machine\_cutting\_tool** in ISO 14649-111, and **Turning\_machine\_cutting\_tool** in ISO 14649-121 for more information.

NOTE The action resource concept is used here because this describes required resources (tools) to perform an action method (machining workingstep). Design information about individual tools (not just usage requirements) can be represented using the product and product\_definition\_formation concepts rather than action\_resource. The machining\_tool\_usage type represents the bridge between these two descriptions.

#### EXPRESS specification:

```

*)
ENTITY machining_tool
  SUBTYPE OF (action_resource);
  WHERE
  WR1: NOT (SELF.kind.name = 'milling cutting tool') OR
        ((0 <= SIZEOF (QUERY (arr <* USEDIN (SELF,
'INTEGRATED_CNC_SCHEMA.ACTION_RESOURCE_RELATIONSHIP.RELATING_RESOURCE') |
  (('INTEGRATED_CNC_SCHEMA.MACHINING_CUTTING_COMPONENT'
    IN TYPEOF (arr.related_resource)) AND
    (arr.related_resource.kind.name = 'milling cutting edge') )))) AND

    (verify_optional_tool_body_item
      (SELF, 'overall assembly length')) AND
    (verify_length_measure_tool_body_item
      (SELF, 'overall assembly length')) AND

    (verify_optional_tool_body_item
      (SELF, 'effective cutting diameter')) AND
    (verify_length_measure_tool_body_item
      (SELF, 'effective cutting diameter')) AND

    (verify_optional_tool_body_item
      (SELF, 'maximum depth of cut')) AND
    (verify_length_measure_tool_body_item
      (SELF, 'maximum depth of cut')) AND

    (verify_optional_tool_body_item (SELF, 'hand of cut')) AND
    (verify_enumeration_tool_body_item (SELF, 'hand of cut',
      ['left', 'right', 'neutral'])) AND

    (verify_optional_tool_body_item (SELF, 'coolant through tool')) AND
    (verify_enumeration_tool_body_item (SELF, 'coolant through tool',
      ['supported', 'not supported']))
  );

  WR2: NOT ((SELF.kind.name = 'milling cutting tool') AND
    (SELF.description IN [ 'counterbore', 'countersink',
      'spade drill', 'spot drill', 'step drill', 'tapered drill',

```

```

    'twist drill', 'drill']))
OR
((verify_optional_tool_body_item      (SELF, 'point angle')) AND
 (verify_angle_measure_tool_body_item (SELF, 'point angle'))
);

WR3: NOT ((SELF.kind.name = 'milling cutting tool') AND
 (SELF.description = 'countersink'))
OR
((verify_optional_tool_body_item
 (SELF, 'minimum cutting diameter')) AND
 (verify_length_measure_tool_body_item
 (SELF, 'minimum cutting diameter')) AND

 (verify_required_tool_body_item
 (SELF, 'maximum usable length')) AND
 (verify_length_measure_tool_body_item
 (SELF, 'maximum usable length'))
);

WR4: NOT ((SELF.kind.name = 'milling cutting tool') AND
 (SELF.description = 'tapered drill'))
OR
((verify_required_tool_body_item      (SELF, 'taper angle')) AND
 (verify_angle_measure_tool_body_item (SELF, 'taper angle'))
);

WR5: NOT ((SELF.kind.name = 'milling cutting tool') AND
 (SELF.description = 'step drill'))
OR
((verify_required_tool_body_item      (SELF, 'step diameters')) AND
 (verify_rep_item_for_tool_body
 (SELF, 'step diameters',
 ['INTEGRATED_CNC_SCHEMA.COMPOUND_REPRESENTATION_ITEM'])) AND

 (verify_required_tool_body_item      (SELF, 'step lengths')) AND
 (verify_rep_item_for_tool_body
 (SELF, 'step lengths',
 ['INTEGRATED_CNC_SCHEMA.COMPOUND_REPRESENTATION_ITEM']))
);

WR6: NOT ((SELF.kind.name = 'milling cutting tool') AND
 (SELF.description IN [ 'ballnose endmill', 'bullnose endmill',
 'dovetail mill', 'endmill', 'facemill', 'profiled endmill',
 'shoulder mill', 'tee slot mill', 'thread mill', 'side mill']))
OR
((verify_optional_tool_body_item
 (SELF, 'number of effective teeth')) AND
 (verify_count_measure_tool_body_item
 (SELF, 'number of effective teeth')) AND

 (verify_optional_tool_body_item      (SELF, 'edge radius')) AND
 (verify_length_measure_tool_body_item (SELF, 'edge radius'))
);

```

```

WR7: NOT ((SELF.kind.name = 'milling cutting tool') AND
  (SELF.description IN [ 'ballnose endmill', 'bullnose endmill',
    'endmill', 'facemill', 'profiled endmill']))
OR
  ((verify_optional_tool_body_item
    (SELF, 'tool cutting edge angle')) AND
    (verify_angle_measure_tool_body_item
      (SELF, 'tool cutting edge angle'))
  );

WR8: NOT ((SELF.kind.name = 'milling cutting tool') AND
  (SELF.description = 'ballnose endmill'))
OR verify_ballnose_endmill_dimensions (SELF);

WR9: NOT ((SELF.kind.name = 'milling cutting tool') AND
  (SELF.description = 'bullnose endmill'))
OR verify_bullnose_endmill_dimensions (SELF);

WR10: NOT ((SELF.kind.name = 'milling cutting tool') AND
  (SELF.description = 'tee slot mill'))
OR
  ((verify_optional_tool_body_item (SELF, 'cutting width')) AND
    (verify_length_measure_tool_body_item (SELF, 'cutting width'))
  );

WR11: NOT ((SELF.kind.name = 'milling cutting tool') AND
  (SELF.description = 'dovetail mill'))
OR
  ((verify_optional_tool_body_item (SELF, 'included angle')) AND
    (verify_angle_measure_tool_body_item (SELF, 'included angle'))
  );

WR12: NOT ((SELF.kind.name = 'milling cutting tool') AND
  (SELF.description = 'side mill'))
OR
  ((verify_optional_tool_body_item (SELF, 'cutter width')) AND
    (verify_length_measure_tool_body_item (SELF, 'cutter width'))
  );

WR13: NOT ((SELF.kind.name = 'milling cutting tool') AND
  (SELF.description IN [ 'thread mill', 'tapping tool',
    'combined drill and tap']))
OR
  ((verify_required_tool_body_item (SELF, 'thread form type')) AND
    (verify_rep_item_for_tool_body (SELF, 'thread form type',
      ['INTEGRATED_CNC_SCHEMA.DESRIPTIVE_REPRESENTATION_ITEM'])) AND
    (verify_required_tool_body_item (SELF, 'thread size')) AND
    (verify_length_measure_tool_body_item (SELF, 'thread size')) AND
    (verify_required_tool_body_item (SELF, 'thread pitch')) AND
    (verify_length_measure_tool_body_item (SELF, 'thread pitch'))
  );

```

```

WR14: NOT ((SELF.kind.name = 'milling cutting tool') AND
  (SELF.description IN [ 'tapping tool', 'combined drill and tap']))
OR
  ((verify_required_tool_body_item
    (SELF, 'taper thread count')) AND
    (verify_count_measure_tool_body_item
      (SELF, 'taper thread count')))
);

WR15: NOT ((SELF.kind.name = 'milling cutting tool') AND
  (SELF.description IN [ 'reamer', 'combined drill and reamer',
    'tapered reamer']))
OR
  ((verify_required_tool_body_item      (SELF, 'taper length')) AND
    (verify_length_measure_tool_body_item (SELF, 'taper length')))
);

WR16: NOT ((SELF.kind.name = 'milling cutting tool') AND
  (SELF.description = 'tapered reamer'))
OR
  ((verify_required_tool_body_item      (SELF, 'taper angle')) AND
    (verify_angle_measure_tool_body_item (SELF, 'taper angle')))
);

WR17: NOT ((SELF.kind.name = 'milling cutting tool') AND
  (SELF.description IN [ 'combined drill and reamer',
    'combined drill and tap']))
OR
  ((verify_required_tool_body_item      (SELF, 'drill length')) AND
    (verify_length_measure_tool_body_item (SELF, 'drill length')))
);

WR18: NOT ((SELF.kind.name = 'milling cutting tool') AND
  (SELF.description = 'boring tool'))
OR
  ((verify_required_tool_body_item      (SELF, 'retract movement')) AND
    (verify_enumeration_tool_body_item (SELF, 'retract movement',
      ['permitted', 'forbidden'])))
);

WR19: NOT ((SELF.kind.name = 'milling cutting tool') AND
  (SELF.description = 'user defined milling tool'))
OR
  ((verify_optional_tool_body_item      (SELF, 'tool description')) AND
    (verify_rep_item_for_tool_body      (SELF, 'tool description',
      ['INTEGRATED_CNC_SCHEMA.DESRIPTIVE_REPRESENTATION_ITEM'])) AND

    (verify_optional_tool_body_item
      (SELF, 'corner radius')) AND
    (verify_length_measure_tool_body_item
      (SELF, 'corner radius')) AND

```

```

(verify_optional_tool_body_item
  (SELF, 'corner radius center horizontal')) AND
(verify_length_measure_tool_body_item
  (SELF, 'corner radius center horizontal')) AND

(verify_optional_tool_body_item
  (SELF, 'corner radius center vertical')) AND
(verify_length_measure_tool_body_item
  (SELF, 'corner radius center vertical')) AND

(verify_optional_tool_body_item      (SELF, 'taper angle')) AND
(verify_angle_measure_tool_body_item (SELF, 'taper angle')) AND

(verify_optional_tool_body_item      (SELF, 'tip outer angle')) AND
(verify_angle_measure_tool_body_item (SELF, 'tip outer angle'))
);

WR20: NOT (SELF.kind.name = 'turning cutting tool') OR
((verify_required_tool_body_item      (SELF, 'functional length')) AND
 (verify_length_measure_tool_body_item (SELF, 'functional length')) AND

 (verify_required_tool_body_item      (SELF, 'f dimension')) AND
 (verify_length_measure_tool_body_item (SELF, 'f dimension')) AND

 (verify_optional_tool_body_item
  (SELF, 'minimum cutting diameter')) AND
 (verify_length_measure_tool_body_item
  (SELF, 'minimum cutting diameter')) AND

 (verify_optional_tool_body_item
  (SELF, 'a dimension on f')) AND
 (verify_length_measure_tool_body_item
  (SELF, 'a dimension on f')) AND

 (verify_optional_tool_body_item
  (SELF, 'a dimension on lf')) AND
 (verify_length_measure_tool_body_item
  (SELF, 'a dimension on lf')) AND

 (verify_optional_tool_body_item      (SELF, 'hand of cut')) AND
 (verify_enumeration_tool_body_item (SELF, 'hand of cut',
  ['left', 'right', 'neutral'])) AND

 (0 <= SIZEOF (QUERY (arr <* USEDIN (SELF,
'INTEGRATED_CNC_SCHEMA.ACTION_RESOURCE_RELATIONSHIP.RELATING_RESOURCE') |
  (('INTEGRATED_CNC_SCHEMA.MACHINING_CUTTING_COMPONENT'
  IN TYPEOF (arr.related_resource)) AND
  (arr.related_resource.kind.name = 'turning cutting edge') ))))
);

WR21: NOT ((SELF.kind.name = 'turning cutting tool') AND
 (SELF.description = 'turning threading tool'))

```

```

OR
((verify_required_tool_body_item      (SELF, 'threading pitch')) AND
 (verify_length_measure_tool_body_item (SELF, 'threading pitch')) AND

 (verify_required_tool_body_item      (SELF, 'thread hand')) AND
 (verify_enumeration_tool_body_item   (SELF, 'thread hand',
 ['left', 'right'])) AND

 (verify_required_tool_body_item      (SELF, 'thread type')) AND
 (verify_enumeration_tool_body_item   (SELF, 'thread type',
 ['internal', 'external'])) AND

 (verify_required_tool_body_item      (SELF, 'thread profile')) AND
 (verify_enumeration_tool_body_item   (SELF, 'thread profile',
 ['full', 'partial'])) AND

 (verify_required_tool_body_item      (SELF, 'thread form type')) AND
 (verify_rep_item_for_tool_body       (SELF, 'thread form type',
 ['INTEGRATED_CNC_SCHEMA.DESRIPTIVE_REPRESENTATION_ITEM']))
);

```

```

WR22: NOT ((SELF.kind.name = 'turning cutting tool') AND
 (SELF.description = 'grooving tool'))

```

```

OR
((verify_required_tool_body_item      (SELF, 'cutting width')) AND
 (verify_length_measure_tool_body_item (SELF, 'cutting width')) AND

 (verify_required_tool_body_item      (SELF, 'maximum grooving depth')) AND
 (verify_length_measure_tool_body_item (SELF, 'maximum grooving depth')) AND

 (verify_optional_tool_body_item      (SELF, 'corner radius')) AND
 (verify_length_measure_tool_body_item (SELF, 'corner radius')) AND

 (verify_optional_tool_body_item      (SELF, 'maximum axial grooving diameter')) AND
 (verify_length_measure_tool_body_item (SELF, 'maximum axial grooving diameter')) AND

 (verify_optional_tool_body_item      (SELF, 'minimum axial grooving diameter')) AND
 (verify_length_measure_tool_body_item (SELF, 'minimum axial grooving diameter'))
);

```

```

WR23: NOT ((SELF.kind.name = 'turning cutting tool') AND
 (SELF.description = 'knurling tool'))

```

```

OR
((verify_required_tool_body_item      (SELF, 'knurl pattern')) AND

```

```

(verify_enumeration_tool_body_item (SELF, 'knurl pattern',
  ['straight', 'diagonal', 'diamond'])) AND

(verify_optional_tool_body_item      (SELF, 'cutting length')) AND
(verify_length_measure_tool_body_item (SELF, 'cutting length')) AND

(verify_optional_tool_body_item      (SELF, 'cutting angle')) AND
(verify_angle_measure_tool_body_item (SELF, 'cutting angle')) AND

(verify_optional_tool_body_item      (SELF, 'cutting pitch')) AND
(verify_length_measure_tool_body_item (SELF, 'cutting pitch'))
);

WR24: NOT ((SELF.kind.name = 'turning cutting tool') AND
  (SELF.description = 'user defined turning tool'))
OR
((verify_required_tool_body_item  (SELF, 'tool identifier')) AND
  (verify_rep_item_for_tool_body  (SELF, 'tool identifier',
  ['INTEGRATED_CNC_SCHEMA.DESRIPTIVE_REPRESENTATION_ITEM'])))
);

WR25: (1 >= SIZEOF (QUERY (rar <* USEDIN (SELF,
  'INTEGRATED_CNC_SCHEMA.REQUIREMENT_FOR_ACTION_RESOURCE.RESOURCES') |
  ((1 = SIZEOF(rar.operations)) AND
  ('INTEGRATED_CNC_SCHEMA.MACHINING_TOOL_USAGE'
  IN TYPEOF (rar\action_resource_requirement.operations[1]))
  )));
END_ENTITY;
(*

```

### Formal propositions:

**WR1:** If the **kind** of the **machining\_tool** is an **action\_resource\_type** with a **name** of 'milling cutting tool', the **machining\_tool** shall satisfy the following conditions:

- the **machining\_tool** is the **relating** in zero or more **action\_resource\_relationship** in which the **related** is of type **machining\_cutting\_component** and the **kind** of the **machining\_cutting\_component** is an **action\_resource\_type** with a **name** of 'milling cutting edge';
- the **machining\_tool** is related to at most one **representation\_item** with a **name** of 'overall assembly length' which shall be of type **measure\_representation\_item** and **length\_measure\_with\_unit**. If present, the **representation\_item** shall appear in the **items** set of a **representation** of type **machining\_tool\_body\_representation** which describes a **resource\_property** with a **name** of 'tool body' and a **resource** which refers to the **machining\_tool**;
- the **machining\_tool** is related to at most one **representation\_item** with a **name** of 'effective cutting diameter' which shall be of type **measure\_representation\_item** and **length\_measure\_with\_unit**. If present, the **representation\_item** shall appear in the **items** set of a **representation** of type **machining\_tool\_body\_representation** which describes a **resource\_property** with a **name** of 'tool body' and a **resource** which refers to the **machining\_tool**;

- the **machining\_tool** is related to at most one **representation\_item** with a **name** of 'maximum depth of cut' which shall be of type **measure\_representation\_item** and **length\_measure\_with\_unit**. If present, the **representation\_item** shall appear in the **items** set of a **representation** of type **machining\_tool\_body\_representation** which describes a **resource\_property** with a **name** of 'tool body' and a **resource** which refers to the **machining\_tool**;
- the **machining\_tool** is related to at most one **representation\_item** with a **name** of 'hand of cut' which shall be of type **descriptive\_representation\_item** with a **description** of 'left', 'right', or 'neutral'. If present, the **representation\_item** shall appear in the **items** set of a **representation** of type **machining\_tool\_body\_representation** which describes a **resource\_property** with a **name** of 'tool body' and a **resource** which refers to the **machining\_tool**;
- the **machining\_tool** is related to at most one **representation\_item** with a **name** of 'coolant through tool', which shall be of type **descriptive\_representation\_item** with a **description** of 'supported', or 'not supported'. If present, the **representation\_item** shall appear in the **items** set of a **representation** of type **machining\_tool\_body\_representation** which describes a **resource\_property** with a **name** of 'tool body' and a **resource** which refers to the **machining\_tool**.

**WR2:** If the **kind** of the **machining\_tool** is an **action\_resource\_type** with a **name** of 'milling cutting tool' and the **description** of the **machining\_tool** is 'counterbore', 'countersink', 'spade drill', 'spot drill', 'step drill', 'tapered drill', 'twist drill', or 'drill', the **machining\_tool** shall satisfy the following conditions:

- the **machining\_tool** is related to at most one **representation\_item** with a **name** of 'point angle' which shall be of type **measure\_representation\_item** and **plane\_angle\_measure\_with\_unit**. If present, the **representation\_item** shall appear in the **items** set of a **representation** of type **machining\_tool\_body\_representation** which describes a **resource\_property** with a **name** of 'tool body' and a **resource** which refers to the **machining\_tool**.

**WR3:** If the **kind** of the **machining\_tool** is an **action\_resource\_type** with a **name** of 'milling cutting tool' and the **description** of the **machining\_tool** is 'countersink', the **machining\_tool** shall satisfy the following conditions:

- the **machining\_tool** is related to at most one **representation\_item** with a **name** of 'minimum cutting diameter' which shall be of type **measure\_representation\_item** and **length\_measure\_with\_unit**. If present, the **representation\_item** shall appear in the **items** set of a **representation** of type **machining\_tool\_body\_representation** which describes a **resource\_property** with a **name** of 'tool body' and a **resource** which refers to the **machining\_tool**;
- the **machining\_tool** is related to exactly one **representation\_item** with a **name** of 'maximum usable length' which shall be of type **measure\_representation\_item** and **length\_measure\_with\_unit**. The **representation\_item** shall appear in the **items** set of a **representation** of type **machining\_tool\_body\_representation** which describes a **resource\_property** with a **name** of 'tool body' and a **resource** which refers to the **machining\_tool**.

**WR4:** If the **kind** of the **machining\_tool** is an **action\_resource\_type** with a **name** of 'milling cutting tool' and the **description** of the **machining\_tool** is 'tapered drill', **machining\_tool** shall satisfy the following conditions:



- the **machining\_tool** is related to exactly one **representation\_item** with a **name** of 'taper angle' which shall be of type **measure\_representation\_item** and **plane\_angle\_measure\_with\_unit**. The **representation\_item** shall appear in the **items** set of a **representation** of type **machining\_tool\_body\_representation** which describes a **resource\_property** with a **name** of 'tool body' and a **resource** which refers to the **machining\_tool**.

**WR5:** If the **kind** of the **machining\_tool** is an **action\_resource\_type** with a **name** of 'milling cutting tool' and the **description** of the **machining\_tool** is 'step drill', **machining\_tool** shall satisfy the following conditions:

- the **machining\_tool** is related to exactly one **representation\_item** with a **name** of 'step diameters' which shall be of type **compound\_representation\_item**. The **representation\_item** shall appear in the **items** set of a **representation** of type **machining\_tool\_body\_representation** which describes a **resource\_property** with a **name** of 'tool body' and a **resource** which refers to the **machining\_tool**;
- the **machining\_tool** is related to exactly one **representation\_item** with a **name** of 'step lengths' which shall be of type **compound\_representation\_item**. The **representation\_item** shall appear in the **items** set of a **representation** of type **machining\_tool\_body\_representation** which describes a **resource\_property** with a **name** of 'tool body' and a **resource** which refers to the **machining\_tool**.

**WR6:** If the **kind** of the **machining\_tool** is an **action\_resource\_type** with a **name** of 'milling cutting tool' and the **description** of the **machining\_tool** is 'ballnose endmill', 'bullnose endmill', 'dovetail mill', 'endmill', 'facemill', 'profiled endmill', 'shoulder mill', 'tee slot mill', 'thread mill', or 'side mill', **machining\_tool** shall satisfy the following conditions:

- the **machining\_tool** is related to at most one **representation\_item** with a **name** of 'number of effective teeth', which shall be of type **measure\_representation\_item** with a **value\_component** of type **count\_measure**. If present, the **representation\_item** shall appear in the **items** set of a **representation** of type **machining\_tool\_body\_representation** which describes a **resource\_property** with a **name** of 'tool body' and a **resource** which refers to the **machining\_tool**;
- the **machining\_tool** is related to at most one **representation\_item** with a **name** of 'edge radius' which shall be of type **measure\_representation\_item** and **length\_measure\_with\_unit**. If present, the **representation\_item** shall appear in the **items** set of a **representation** of type **machining\_tool\_body\_representation** which describes a **resource\_property** with a **name** of 'tool body' and a **resource** which refers to the **machining\_tool**.

**WR7:** If the **kind** of the **machining\_tool** is an **action\_resource\_type** with a **name** of 'milling cutting tool' and the **description** of the **machining\_tool** is 'ballnose endmill', 'bullnose endmill', 'endmill', 'facemill', or 'profiled endmill', the **machining\_tool** shall satisfy the following conditions:

- the **machining\_tool** is related to at most one **representation\_item** with a **name** of 'tool cutting edge angle' which shall be of type **measure\_representation\_item** and **plane\_angle\_measure\_with\_unit**. If present, the **representation\_item** shall appear in the **items** set of a **representation** of type **machining\_tool\_body\_representation** which describes a **resource\_property** with a **name** of 'tool body' and a **resource** which refers to the **machining\_tool**.

**WR8:** If the **kind** of the **machining\_tool** is an **action\_resource\_type** with a **name** of 'milling cutting tool' and the **description** of the **machining\_tool** is 'ballnose endmill', the conditions tested by the **verify\_ballnose\_endmill\_dimensions** shall be satisfied.

NOTE This corresponds to the local constraint **WR1** on **Ballnose\_endmill** in ISO 14649-111

**WR9:** If the **kind** of the **machining\_tool** is an **action\_resource\_type** with a **name** of 'milling cutting tool' and the **description** of the **machining\_tool** is 'bullnose endmill', the conditions tested by the **verify\_bullnose\_endmill\_dimensions** shall be satisfied.

NOTE This corresponds to the local constraint **WR1** on **Bullnose\_endmill** in ISO 14649-111

**WR10:** If the **kind** of the **machining\_tool** is an **action\_resource\_type** with a **name** of 'milling cutting tool' and the **description** of the **machining\_tool** is 'tee slot mill', the **machining\_tool** shall satisfy the following conditions:

- the **machining\_tool** is related to at most one **representation\_item** with a **name** of 'cutting width' which shall be of type **measure\_representation\_item** and **length\_measure\_with\_unit**. If present, the **representation\_item** shall appear in the **items** set of a **representation** of type **machining\_tool\_body\_representation** which describes a **resource\_property** with a **name** of 'tool body' and a **resource** which refers to the **machining\_tool**.

**WR11:** If the **kind** of the **machining\_tool** is an **action\_resource\_type** with a **name** of 'milling cutting tool' and the **description** of the **machining\_tool** is 'dovetail mill', the **machining\_tool** shall satisfy the following conditions:

- the **machining\_tool** is related to at most one **representation\_item** with a **name** of 'included angle' which shall be of type **measure\_representation\_item** and **plane\_angle\_measure\_with\_unit**. If present, the **representation\_item** shall appear in the **items** set of a **representation** of type **machining\_tool\_body\_representation** which describes a **resource\_property** with a **name** of 'tool body' and a **resource** which refers to the **machining\_tool**.

**WR12:** If the **kind** of the **machining\_tool** is an **action\_resource\_type** with a **name** of 'milling cutting tool' and the **description** of the **machining\_tool** is 'side mill', the **machining\_tool** shall satisfy the following conditions:

- the **machining\_tool** is related to at most one **representation\_item** with a **name** of 'cutter width' which shall be of type **measure\_representation\_item** and **length\_measure\_with\_unit**. If present, the **representation\_item** shall appear in the **items** set of a **representation** of type **machining\_tool\_body\_representation** which describes a **resource\_property** with a **name** of 'tool body' and a **resource** which refers to the **machining\_tool**.

**WR13:** If the **kind** of the **machining\_tool** is an **action\_resource\_type** with a **name** of 'milling cutting tool' and the **description** of the **machining\_tool** is 'thread mill', 'tapping tool', or 'combined drill and tap', the **machining\_tool** shall satisfy the following conditions:

- the **machining\_tool** is related to exactly one **representation\_item** with a **name** of 'thread form type' which shall be of type **descriptive\_representation\_item**. The **representation\_item** shall appear in the **items** set of a **representation** of type **machining\_tool\_body\_representation** which

describes a **resource\_property** with a **name** of 'tool body' and a **resource** which refers to the **machining\_tool**;

- the **machining\_tool** is related to exactly one **representation\_item** with a **name** of 'thread size' which shall be of type **measure\_representation\_item** and **length\_measure\_with\_unit**. The **representation\_item** shall appear in the **items** set of a **representation** of type **machining\_tool\_body\_representation** which describes a **resource\_property** with a **name** of 'tool body' and a **resource** which refers to the **machining\_tool**;
- the **machining\_tool** is related to exactly one **representation\_item** with a **name** of 'thread pitch' which shall be of type **measure\_representation\_item** and **length\_measure\_with\_unit**. The **representation\_item** shall appear in the **items** set of a **representation** of type **machining\_tool\_body\_representation** which describes a **resource\_property** with a **name** of 'tool body' and a **resource** which refers to the **machining\_tool**.

**WR14:** If the **kind** of the **machining\_tool** is an **action\_resource\_type** with a **name** of 'milling cutting tool' and the **description** of the **machining\_tool** is 'tapping tool' or 'combined drill and tap', the **machining\_tool** shall satisfy the following conditions:

- the **machining\_tool** is related to exactly one **representation\_item** with a **name** of 'number of effective teeth', which shall be of type **measure\_representation\_item** with a **value\_component** of type **count\_measure**. The **representation\_item** shall appear in the **items** set of a **representation** of type **machining\_tool\_body\_representation** which describes a **resource\_property** with a **name** of 'tool body' and a **resource** which refers to the **machining\_tool**.

**WR15:** If the **kind** of the **machining\_tool** is an **action\_resource\_type** with a **name** of 'milling cutting tool' and the **description** of the **machining\_tool** is 'reamer', 'combined drill and reamer', or 'tapered reamer', the **machining\_tool** shall satisfy the following conditions:

- the **machining\_tool** is related to exactly one **representation\_item** with a **name** of 'taper length' which shall be of type **measure\_representation\_item** and **length\_measure\_with\_unit**. The **representation\_item** shall appear in the **items** set of a **representation** of type **machining\_tool\_body\_representation** which describes a **resource\_property** with a **name** of 'tool body' and a **resource** which refers to the **machining\_tool**.

**WR16:** If the **kind** of the **machining\_tool** is an **action\_resource\_type** with a **name** of 'milling cutting tool' and the **description** of the **machining\_tool** is 'tapered reamer', the **machining\_tool** shall satisfy the following conditions:

- the **machining\_tool** is related to exactly one **representation\_item** with a **name** of 'taper angle' which shall be of type **measure\_representation\_item** and **plane\_angle\_measure\_with\_unit**. The **representation\_item** shall appear in the **items** set of a **representation** of type **machining\_tool\_body\_representation** which describes a **resource\_property** with a **name** of 'tool body' and a **resource** which refers to the **machining\_tool**.

**WR17:** If the **kind** of the **machining\_tool** is an **action\_resource\_type** with a **name** of 'milling cutting tool' and the **description** of the **machining\_tool** is 'combined drill and reamer' or 'combined drill and tap', the **machining\_tool** shall satisfy the following conditions:

- the **machining\_tool** is related to exactly one **representation\_item** with a **name** of 'drill length' which shall be of type **measure\_representation\_item** and **length\_measure\_with\_unit**. The **representation\_item** shall appear in the **items** set of a **representation** of type **machining\_tool\_body\_representation** which describes a **resource\_property** with a **name** of 'tool body' and a **resource** which refers to the **machining\_tool**.

**WR18:** If the **kind** of the **machining\_tool** is an **action\_resource\_type** with a **name** of 'milling cutting tool' and the **description** of the **machining\_tool** is 'boring tool', the **machining\_tool** shall satisfy the following conditions:

- the **machining\_tool** is related to exactly one **representation\_item** with a **name** of 'retract movement', which shall be of type **descriptive\_representation\_item** with a **description** of 'permitted' or 'forbidden'. The **representation\_item** shall appear in the **items** set of a **representation** of type **machining\_tool\_body\_representation** which describes a **resource\_property** with a **name** of 'tool body' and a **resource** which refers to the **machining\_tool**.

**WR19:** If the **kind** of the **machining\_tool** is an **action\_resource\_type** with a **name** of 'milling cutting tool' and the **description** of the **machining\_tool** is 'user defined milling tool', the **machining\_tool** shall satisfy the following conditions:

- the **machining\_tool** is related to at most one **representation\_item** with a **name** of 'tool description', which shall be of type **descriptive\_representation\_item**. The **representation\_item** shall appear in the **items** set of a **representation** of type **machining\_tool\_body\_representation** which describes a **resource\_property** with a **name** of 'tool body' and a **resource** which refers to the **machining\_tool**;
- the **machining\_tool** is related to at most one **representation\_item** with a **name** of 'corner radius' which shall be of type **measure\_representation\_item** and **length\_measure\_with\_unit**. If present, the **representation\_item** shall appear in the **items** set of a **representation** of type **machining\_tool\_body\_representation** which describes a **resource\_property** with a **name** of 'tool body' and a **resource** which refers to the **machining\_tool**;
- the **machining\_tool** is related to at most one **representation\_item** with a **name** of 'corner radius center horizontal' which shall be of type **measure\_representation\_item** and **length\_measure\_with\_unit**. If present, the **representation\_item** shall appear in the **items** set of a **representation** of type **machining\_tool\_body\_representation** which describes a **resource\_property** with a **name** of 'tool body' and a **resource** which refers to the **machining\_tool**;
- the **machining\_tool** is related to at most one **representation\_item** with a **name** of 'corner radius center vertical' which shall be of type **measure\_representation\_item** and **length\_measure\_with\_unit**. If present, the **representation\_item** shall appear in the **items** set of a **representation** of type **machining\_tool\_body\_representation** which describes a **resource\_property** with a **name** of 'tool body' and a **resource** which refers to the **machining\_tool**;
- the **machining\_tool** is related to at most one **representation\_item** with a **name** of 'taper angle' which shall be of type **measure\_representation\_item** and **plane\_angle\_measure\_with\_unit**. If present, the **representation\_item** shall appear in the **items** set of a **representation** of type **machining\_tool\_body\_representation** which describes a **resource\_property** with a **name** of 'tool body' and a **resource** which refers to the **machining\_tool**;

- the **machining\_tool** is related to at most one **representation\_item** with a **name** of 'tip outer angle' which shall be of type **measure\_representation\_item** and **plane\_angle\_measure\_with\_unit**. If present, the **representation\_item** shall appear in the **items** set of a **representation** of type **machining\_tool\_body\_representation** which describes a **resource\_property** with a **name** of 'tool body' and a **resource** which refers to the **machining\_tool**.

**WR20:** If the **kind** of the **machining\_tool** is an **action\_resource\_type** with a **name** of 'turning cutting tool', the **machining\_tool** shall satisfy the following conditions:

- the **machining\_tool** is related to exactly one **representation\_item** with a **name** of 'functional length' which shall be of type **measure\_representation\_item** and **length\_measure\_with\_unit**. The **representation\_item** shall appear in the **items** set of a **representation** of type **machining\_tool\_body\_representation** which describes a **resource\_property** with a **name** of 'tool body' and a **resource** which refers to the **machining\_tool**;
- the **machining\_tool** is related to exactly one **representation\_item** with a **name** of 'f dimension' which shall be of type **measure\_representation\_item** and **length\_measure\_with\_unit**. The **representation\_item** shall appear in the **items** set of a **representation** of type **machining\_tool\_body\_representation** which describes a **resource\_property** with a **name** of 'tool body' and a **resource** which refers to the **machining\_tool**;
- the **machining\_tool** is related to at most one **representation\_item** with a **name** of 'minimum cutting diameter' which shall be of type **measure\_representation\_item** and **length\_measure\_with\_unit**. If present, the **representation\_item** shall appear in the **items** set of a **representation** of type **machining\_tool\_body\_representation** which describes a **resource\_property** with a **name** of 'tool body' and a **resource** which refers to the **machining\_tool**;
- the **machining\_tool** is related to at most one **representation\_item** with a **name** of 'a dimension on f' which shall be of type **measure\_representation\_item** and **length\_measure\_with\_unit**. If present, the **representation\_item** shall appear in the **items** set of a **representation** of type **machining\_tool\_body\_representation** which describes a **resource\_property** with a **name** of 'tool body' and a **resource** which refers to the **machining\_tool**;
- the **machining\_tool** is related to at most one **representation\_item** with a **name** of 'a dimension on lf' which shall be of type **measure\_representation\_item** and **length\_measure\_with\_unit**. If present, the **representation\_item** shall appear in the **items** set of a **representation** of type **machining\_tool\_body\_representation** which describes a **resource\_property** with a **name** of 'tool body' and a **resource** which refers to the **machining\_tool**;
- the **machining\_tool** is related to at most one **representation\_item** with a **name** of 'hand of cut' which shall be of type **descriptive\_representation\_item** with a **description** of 'left', 'right', or 'neutral'. If present, the **representation\_item** shall appear in the **items** set of a **representation** of type **machining\_tool\_body\_representation** which describes a **resource\_property** with a **name** of 'tool body' and a **resource** which refers to the **machining\_tool**;
- the **machining\_tool** is the **relating** in zero or more **action\_resource\_relationship** in which the **related** is of type **machining\_cutting\_component** and the **kind** of the **machining\_cutting\_component** is an **action\_resource\_type** with a **name** of 'turning cutting edge'.

**WR21:** If the **kind** of the **machining\_tool** is an **action\_resource\_type** with a **name** of 'turning cutting tool' and the **description** of the **machining\_tool** is 'turning threading tool', the **machining\_tool** shall satisfy the following conditions:

- the **machining\_tool** is related to exactly one **representation\_item** with a **name** of 'thread pitch' which shall be of type **measure\_representation\_item** and **length\_measure\_with\_unit**. The **representation\_item** shall appear in the **items** set of a **representation** of type **machining\_tool\_body\_representation** which describes a **resource\_property** with a **name** of 'tool body' and a **resource** which refers to the **machining\_tool**;
- the **machining\_tool** is related to exactly one **representation\_item** with a **name** of 'thread hand' which shall be of type **descriptive\_representation\_item** with a **description** of 'left' or 'right'. The **representation\_item** shall appear in the **items** set of a **representation** of type **machining\_tool\_body\_representation** which describes a **resource\_property** with a **name** of 'tool body' and a **resource** which refers to the **machining\_tool**;
- the **machining\_tool** is related to exactly one **representation\_item** with a **name** of 'thread type' which shall be of type **descriptive\_representation\_item** with a **description** of 'internal' or 'external'. The **representation\_item** shall appear in the **items** set of a **representation** of type **machining\_tool\_body\_representation** which describes a **resource\_property** with a **name** of 'tool body' and a **resource** which refers to the **machining\_tool**;
- the **machining\_tool** is related to exactly one **representation\_item** with a **name** of 'thread profile' which shall be of type **descriptive\_representation\_item** with a **description** of 'full' or 'partial'. The **representation\_item** shall appear in the **items** set of a **representation** of type **machining\_tool\_body\_representation** which describes a **resource\_property** with a **name** of 'tool body' and a **resource** which refers to the **machining\_tool**;
- the **machining\_tool** is related to exactly one **representation\_item** with a **name** of 'thread form type' which shall be of type **descriptive\_representation\_item**. The **representation\_item** shall appear in the **items** set of a **representation** of type **machining\_tool\_body\_representation** which describes a **resource\_property** with a **name** of 'tool body' and a **resource** which refers to the **machining\_tool**.

**WR22:** If the **kind** of the **machining\_tool** is an **action\_resource\_type** with a **name** of 'turning cutting tool' and the **description** of the **machining\_tool** is 'grooving tool', the **machining\_tool** shall satisfy the following conditions:

- the **machining\_tool** is related to exactly one **representation\_item** with a **name** of 'cutting width' which shall be of type **measure\_representation\_item** and **length\_measure\_with\_unit**. The **representation\_item** shall appear in the **items** set of a **representation** of type **machining\_tool\_body\_representation** which describes a **resource\_property** with a **name** of 'tool body' and a **resource** which refers to the **machining\_tool**;
- the **machining\_tool** is related to exactly one **representation\_item** with a **name** of 'maximum grooving depth' which shall be of type **measure\_representation\_item** and **length\_measure\_with\_unit**. The **representation\_item** shall appear in the **items** set of a **representation** of type **machining\_tool\_body\_representation** which describes a **resource\_property** with a **name** of 'tool body' and a **resource** which refers to the **machining\_tool**;

- the **machining\_tool** is related to at most one **representation\_item** with a **name** of 'corner radius' which shall be of type **measure\_representation\_item** and **length\_measure\_with\_unit**. If present, the **representation\_item** shall appear in the **items** set of a **representation** of type **machining\_tool\_body\_representation** which describes a **resource\_property** with a **name** of 'tool body' and a **resource** which refers to the **machining\_tool**;
- the **machining\_tool** is related to at most one **representation\_item** with a **name** of 'maximum axial grooving diameter' which shall be of type **measure\_representation\_item** and **length\_measure\_with\_unit**. If present, the **representation\_item** shall appear in the **items** set of a **representation** of type **machining\_tool\_body\_representation** which describes a **resource\_property** with a **name** of 'tool body' and a **resource** which refers to the **machining\_tool**;
- the **machining\_tool** is related to at most one **representation\_item** with a **name** of 'minimum axial grooving diameter' which shall be of type **measure\_representation\_item** and **length\_measure\_with\_unit**. If present, the **representation\_item** shall appear in the **items** set of a **representation** of type **machining\_tool\_body\_representation** which describes a **resource\_property** with a **name** of 'tool body' and a **resource** which refers to the **machining\_tool**.

**WR23:** If the **kind** of the **machining\_tool** is an **action\_resource\_type** with a **name** of 'turning cutting tool' and the **description** of the **machining\_tool** is 'knurling tool', the **machining\_tool** shall satisfy the following conditions:

- the **machining\_tool** is related to exactly one **representation\_item** with a **name** of 'knurl pattern' which shall be of type **descriptive\_representation\_item** with a **description** of 'straight', 'diagonal', or 'diamond'. The **representation\_item** shall appear in the **items** set of a **representation** of type **machining\_tool\_body\_representation** which describes a **resource\_property** with a **name** of 'tool body' and a **resource** which refers to the **machining\_tool**;
- the **machining\_tool** is related to at most one **representation\_item** with a **name** of 'cutting length' which shall be of type **measure\_representation\_item** and **length\_measure\_with\_unit**. If present, the **representation\_item** shall appear in the **items** set of a **representation** of type **machining\_tool\_body\_representation** which describes a **resource\_property** with a **name** of 'tool body' and a **resource** which refers to the **machining\_tool**;
- the **machining\_tool** is related to at most one **representation\_item** with a **name** of 'cutting angle' which shall be of type **measure\_representation\_item** and **plane\_angle\_measure\_with\_unit**. If present, the **representation\_item** shall appear in the **items** set of a **representation** of type **machining\_tool\_body\_representation** which describes a **resource\_property** with a **name** of 'tool body' and a **resource** which refers to the **machining\_tool**;
- the **machining\_tool** is related to at most one **representation\_item** with a **name** of 'cutting pitch' which shall be of type **measure\_representation\_item** and **length\_measure\_with\_unit**. If present, the **representation\_item** shall appear in the **items** set of a **representation** of type **machining\_tool\_body\_representation** which describes a **resource\_property** with a **name** of 'tool body' and a **resource** which refers to the **machining\_tool**.

**WR24:** If the **kind** of the **machining\_tool** is an **action\_resource\_type** with a **name** of 'turning cutting tool' and the **description** of the **machining\_tool** is 'user defined turning tool', the **machining\_tool** shall satisfy the following conditions:

— the **machining\_tool** is related to exactly one **representation\_item** with a **name** of 'tool identifier', which shall be of type **descriptive\_representation\_item**. The **representation\_item** shall appear in the **items** set of a **representation** of type **machining\_tool\_body\_representation** which describes a **resource\_property** with a **name** of 'tool body' and a **resource** which refers to the **machining\_tool**.

**WR25:** The **machining\_tool** shall be a member of the **resources** attribute of at most one **requirement\_for\_action\_resource** which has an **operations** attribute containing a single instance which is of type **machining\_tool\_usage**.

Informal propositions:

**IP1:** The **machining\_tool** name shall be unique.

### 5.2.3.1.73 machining\_tool\_body\_representation

A **machining\_tool\_body\_representation** is a type of **representation** that describes the body configuration parameters of a tool for machining.

EXPRESS specification:

```
*)
ENTITY machining_tool_body_representation
  SUBTYPE OF (representation);
END_ENTITY;
(*
```

### 5.2.3.1.74 machining\_tool\_direction\_representation

A **machining\_tool\_direction\_representation** is a type of **representation** that represents direction of the cutting tool for freeform machining. See the ARM definition for **Tool\_direction** in ISO 14649-10 for more information.

EXPRESS specification:

```
*)
ENTITY machining_tool_direction_representation
  SUBTYPE OF (representation);
  WHERE
  WR1: (SELF.name IN ['two axes', 'three axes', 'three axes tilted tool',
    'five axes const tilt yaw', 'five axes var tilt yaw']);

  WR2: NOT (SELF.name = 'three axes tilted tool') OR
    ((verify_required_rep_item (SELF, 'tool direction orientation'))
AND
  (0 = SIZEOF (QUERY ( it <* SELF.items |
    (it.name = 'tool direction orientation') AND NOT
    ('INTEGRATED_CNC_SCHEMA.DIRECTION' IN TYPEOF(it))))
  );
```



```

WR3: NOT (SELF.name = 'five axes const tilt yaw') OR
      ((verify_required_rep_item      (SELF, 'tool direction tilt angle')) AND
       (verify_angle_measure_rep_item (SELF, 'tool direction tilt angle')) AND
       (verify_required_rep_item      (SELF, 'tool direction yaw angle')) AND
       (verify_angle_measure_rep_item (SELF, 'tool direction yaw angle'))
      );
END_ENTITY;
(*)

```

### Formal propositions:

**WR1:** The **name** of the **machining\_tool\_direction\_representation** shall be either 'two axes', 'three axes', 'three axes tilted tool', 'five axes const tilt yaw', or 'five axes var tilt yaw'.

**WR2:** If the **name** of the **machining\_tool\_direction\_representation** is 'three axes tilted tool', the **items** set shall contain exactly one **representation\_item** with a **name** of 'tool direction orientation', which shall be of type **direction**.

**WR3:** If the **name** of the **machining\_tool\_direction\_representation** is 'five axes const tilt yaw', the **items** set shall contain exactly one **representation\_item** with a **name** of 'tool direction tilt angle', which shall be of type **measure\_representation\_item** and **plane\_angle\_measure\_with\_unit**, and the **items** set shall also contain exactly one **representation\_item** with a **name** of 'tool direction yaw angle', which shall be of type **measure\_representation\_item** and **plane\_angle\_measure\_with\_unit**.

### 5.2.3.1.75 machining\_tool\_usage

A **machining\_tool\_usage** is a type of **action\_method** that represents tool usage to satisfy requirements for machining. See the ARM definition for Tool\_usage in 4.2.370 for more information.

#### EXPRESS specification:

```

*)
ENTITY machining_tool_usage
  SUBTYPE OF (action_method);
  WHERE
  WR1: ((verify_optional_action_property      (SELF, 'tool position')) AND
        (verify_descriptive_action_property (SELF, 'tool position')));

  WR2: ((verify_optional_action_property      (SELF, 'tool carousel')) AND
        (verify_descriptive_action_property (SELF, 'tool carousel')));

  WR3: (1 >= SIZEOF (QUERY (act <*
    USEDIN (SELF, 'INTEGRATED_CNC_SCHEMA.ACTION.CHOSEN_METHOD') |
    (act.name = 'tool usage')))) AND
    (0 = SIZEOF (QUERY (act <*
    USEDIN (SELF, 'INTEGRATED_CNC_SCHEMA.ACTION.CHOSEN_METHOD') |
    (act.name = 'tool usage') AND NOT
    ('INTEGRATED_CNC_SCHEMA.PRODUCT_DEFINITION_PROCESS' IN TYPEOF (act))
    )));
END_ENTITY;
(*)

```

Formal propositions:

**WR1:** The **machining\_tool\_usage** shall be the **definition** of at most one **action\_property** with a **name** of 'tool position', and the **representation** used to describe the **action\_property** shall contain a **representation\_item** of type **descriptive\_representation\_item**.

**WR2:** The **machining\_tool\_usage** shall be the **definition** of at most one **action\_property** with a **name** of 'tool carousel', and the **representation** used to describe the **action\_property** shall contain a **representation\_item** of type **descriptive\_representation\_item**.

**WR3:** The **machining\_tool\_usage** shall be the **chosen\_method** of at most one **product\_definition\_process** with a **name** of 'tool usage'.

### 5.2.3.1.76 machining\_toolpath

A **machining\_toolpath** is a type of **action\_method** that restricts a step in a machining process to use a specific movement of the machine axes. See the ARM definitions for Toolpath and subtypes in ISO 14649-10 for more information.

EXPRESS specification:

\*)

```

ENTITY machining_toolpath
  SUBTYPE OF (action_method);
  WHERE
  WR1: (SELF.description IN ['feedstop', 'axis trajectory',
    'cutter location trajectory', 'cutter contact trajectory',
    'approach lift path angle', 'approach lift path tangent',
    'connect security plane', 'connect direct']);

  WR2: (verify_optional_action_property      (SELF, 'priority')) AND
    (verify_enumeration_action_property     (SELF, 'priority',
    ['required', 'suggested']));

  WR3: (verify_optional_action_property      (SELF, 'trajectory type')) AND
    (verify_enumeration_action_property     (SELF, 'trajectory type',
    ['approach', 'lift', 'connect', 'non-contact',
    'contact', 'trajectory path']));

  WR4: ((verify_optional_action_property     (SELF, 'speed profile')) AND
    (0 = SIZEOF (QUERY (prop <*
    get_action_property (SELF, 'speed profile') | NOT
    (0 < SIZEOF (QUERY (prep <* USEDIN (prop,
    'INTEGRATED_CNC_SCHEMA.' +
    'ACTION_PROPERTY_REPRESENTATION.PROPERTY') |
    ('INTEGRATED_CNC_SCHEMA.' +
    'MACHINING_TOOLPATH_SPEED_PROFILE_REPRESENTATION'
    IN TYPEOF (prep.representation)) )))
    )))
);

```

```

WR5: (verify_optional_relatng_amr (SELF,
    ['INTEGRATED_CNC_SCHEMA.MACHINING_TECHNOLOGY_RELATIONSHIP'])) AND
(verify_related_type_for_amr (SELF,
    ['INTEGRATED_CNC_SCHEMA.MACHINING_TECHNOLOGY_RELATIONSHIP'],
    ['INTEGRATED_CNC_SCHEMA.MACHINING_TECHNOLOGY']));

WR6: (verify_optional_relatng_amr (SELF,
    ['INTEGRATED_CNC_SCHEMA.MACHINING_FUNCTIONS_RELATIONSHIP'])) AND
(verify_related_type_for_amr (SELF,
    ['INTEGRATED_CNC_SCHEMA.MACHINING_FUNCTIONS_RELATIONSHIP'],
    ['INTEGRATED_CNC_SCHEMA.MACHINING_FUNCTIONS']));

WR7: NOT (SELF.description IN ['axis trajectory',
    'cutter location trajectory',
    'cutter contact trajectory']) OR
((verify_optional_action_property (SELF, 'direction')) AND
(verify_enumeration_action_property (SELF, 'direction',
    ['beginning to end', 'end to beginning']))
);

WR8: NOT (SELF.description = 'connect security plane') OR
((verify_optional_action_property (SELF, 'up direction')) AND
(verify_rep_item_for_action_property (SELF, 'up direction',
    ['INTEGRATED_CNC_SCHEMA.DIRECTION'])) AND

(verify_optional_action_property (SELF, 'down direction')) AND
(verify_rep_item_for_action_property (SELF, 'down direction',
    ['INTEGRATED_CNC_SCHEMA.DIRECTION']))
);

WR9: NOT (SELF.description = 'feedstop') OR
((verify_required_action_property (SELF, 'dwell')) AND
(verify_time_measure_action_property (SELF, 'dwell'))
);

WR10: NOT (SELF.description = 'axis trajectory') OR
((verify_required_action_property (SELF, 'axis commands')) AND

-- axis commands property must contain one or more bounded curves
(0 = SIZEOF (QUERY (prop <* get_action_property (SELF, 'axis commands')

|
    NOT ((0 < SIZEOF (QUERY (prep <* USEDIN (prop,
        'INTEGRATED_CNC_SCHEMA.ACTION_PROPERTY_REPRESENTATION.PROPERTY')

|
        (1 <= SIZEOF (QUERY (it <* prep.representation.items |
            ('INTEGRATED_CNC_SCHEMA.BOUNDED_CURVE' in TYPEOF(it))))
        ))))))
);

WR11: NOT (SELF.description IN ['approach lift path angle',

```

```

    'approach lift path tangent']) OR
((verify_required_action_property      (SELF, 'fix point')) AND
 (verify_rep_item_for_action_property (SELF, 'fix point',
    ['INTEGRATED_CNC_SCHEMA.CARTESIAN_POINT'])) AND

 (verify_optional_action_property      (SELF, 'fix point direction')) AND
 (verify_rep_item_for_action_property (SELF, 'fix point direction',
    ['INTEGRATED_CNC_SCHEMA.DIRECTION']))
);

WR12: NOT (SELF.description = 'approach lift path angle') OR
((verify_required_action_property      (SELF, 'angle')) AND
 (verify_angle_measure_action_property (SELF, 'angle')) AND

 (verify_required_action_property      (SELF, 'bend distance')) AND
 (verify_length_measure_action_property (SELF, 'bend distance'))
);

WR13: NOT (SELF.description = 'approach lift path tangent') OR
((verify_required_action_property      (SELF, 'radius')) AND
 (verify_length_measure_action_property (SELF, 'radius'))
);

WR14: NOT (SELF.description = 'cutter location trajectory') OR
((verify_required_action_property      (SELF, 'basic curve')) AND
 (verify_rep_item_for_action_property (SELF, 'basic curve',
    ['INTEGRATED_CNC_SCHEMA.BOUNDED_CURVE'])) AND

 (verify_optional_action_property      (SELF, 'surface normal')) AND
 (verify_rep_item_for_action_property (SELF, 'surface normal',
    ['INTEGRATED_CNC_SCHEMA.BOUNDED_CURVE'])) AND

 (verify_optional_action_property      (SELF, 'tool axis')) AND
 (verify_rep_item_for_action_property (SELF, 'tool axis',
    ['INTEGRATED_CNC_SCHEMA.BOUNDED_CURVE'])) AND

 (verify_optional_action_property
 (SELF, 'path maximum deviation')) AND
 (verify_length_measure_action_property
 (SELF, 'path maximum deviation')) AND

 (verify_optional_action_property
 (SELF, 'tool axis maximum deviation')) AND
 (verify_angle_measure_action_property
 (SELF, 'tool axis maximum deviation'))
);

WR15: NOT (SELF.description = 'cutter contact trajectory') OR
(((verify_required_action_property      (SELF, 'basic curve')) AND
 (verify_rep_item_for_action_property (SELF, 'basic curve',
    ['INTEGRATED_CNC_SCHEMA.BOUNDED_PCURVE']))) )

OR

```

```

((verify_required_action_property      (SELF, 'basic curve')) AND
 (verify_rep_item_for_action_property (SELF, 'basic curve',
 ['INTEGRATED_CNC_SCHEMA.BOUNDED_CURVE'])) AND

 (verify_required_action_property      (SELF, 'surface normal')) AND
 (verify_rep_item_for_action_property (SELF, 'surface normal',
 ['INTEGRATED_CNC_SCHEMA.BOUNDED_CURVE'])) )
) AND

(verify_optional_action_property      (SELF, 'tool axis')) AND
(verify_rep_item_for_action_property (SELF, 'tool axis',
 ['INTEGRATED_CNC_SCHEMA.BOUNDED_CURVE'])) AND

(verify_optional_action_property      (SELF, 'contact type')) AND
(verify_enumeration_action_property (SELF, 'contact type',
 ['side', 'front'])) AND

(verify_optional_action_property
 (SELF, 'path maximum deviation')) AND
(verify_length_measure_action_property
 (SELF, 'path maximum deviation')) AND

(verify_optional_action_property
 (SELF, 'tool axis maximum deviation')) AND
(verify_angle_measure_action_property
 (SELF, 'tool axis maximum deviation'))
);

WR16: NOT (SELF.description IN ['axis trajectory',
 'cutter location trajectory',
 'cutter contact trajectory']) OR
((verify_optional_action_property
 (SELF, 'material removal depth')) AND
 ((verify_length_measure_action_property
 (SELF, 'material removal depth')) OR
 (verify_rep_item_for_action_property
 (SELF, 'material removal depth',
 ['INTEGRATED_CNC_SCHEMA.BOUNDED_CURVE'])))) AND

(verify_optional_action_property
 (SELF, 'material removal overcut')) AND
((verify_length_measure_action_property
 (SELF, 'material removal overcut')) OR
 (verify_rep_item_for_action_property
 (SELF, 'material removal overcut',
 ['INTEGRATED_CNC_SCHEMA.BOUNDED_CURVE'])))) AND

(verify_optional_action_property
 (SELF, 'material removal total volume')) AND
(verify_rep_item_for_action_property
 (SELF, 'material removal total volume',
 ['INTEGRATED_CNC_SCHEMA.MEASURE_REPRESENTATION_ITEM']))
);

```

END\_ENTITY;  
(\*

Formal propositions:

**WR1:** The **description** of the **machining\_toolpath** shall be either 'feedstop', 'axis trajectory', 'cutter location trajectory', 'cutter contact trajectory', 'approach lift path angle', 'approach lift path tangent', 'connect security plane', or 'connect direct'.

**WR2:** The **machining\_toolpath** shall be the **definition** of at most one **action\_property** with a **name** of 'priority', and the **representation** used to describe the **action\_property** shall contain a **representation\_item** of type **descriptive\_representation\_item** with a **description** of 'required' or 'suggested'.

**WR3:** The **machining\_toolpath** shall be the **definition** of at most one **action\_property** with a **name** of 'trajectory type', and the **representation** used to describe the **action\_property** shall contain a **representation\_item** of type **descriptive\_representation\_item** with a **description** of 'approach', 'lift', 'connect', 'non-contact', 'contact', or 'trajectory path'.

**WR4:** The **machining\_toolpath** shall be the **definition** of at most one **action\_property** with a **name** of 'speed profile', and the **representation** used to describe the **action\_property** shall be of type **machining\_toolpath\_speed\_profile\_representation**.

**WR5:** The **machining\_toolpath** shall be the **relating\_method** of at most one **machining\_technology\_relationship**, in which the **related\_method** shall be of type **machining\_technology**.

**WR6:** The **machining\_toolpath** shall be the **relating\_method** of at most one **machining\_functions\_relationship**, in which the **related\_method** shall be of type **machining\_functions**.

**WR7:** If the **description** of the **machining\_toolpath** is 'axis trajectory', 'cutter location trajectory', or 'cutter contact trajectory', the **machining\_toolpath** shall be the **definition** of at most one **action\_property** with a **name** of 'direction', and the **representation** used to describe the **action\_property** shall contain a **representation\_item** of type **descriptive\_representation\_item** with a **description** of 'beginning to end' or 'end to beginning'.

**WR8:** If the **description** of the **machining\_toolpath** is 'connect security plane', the **machining\_toolpath** shall satisfy the following conditions:

- the **machining\_toolpath** shall be the **definition** of at most one **action\_property** with a **name** of 'up direction', and the **representation** used to describe the **action\_property** shall contain a **representation\_item** of type **direction**;
- the **machining\_toolpath** shall be the **definition** of at most one **action\_property** with a **name** of 'down direction', and the **representation** used to describe the **action\_property** shall contain a **representation\_item** of type **direction**.

**WR9:** If the **description** of the **machining\_toolpath** is 'feedstop', the **machining\_toolpath** shall be the **definition** of exactly one **action\_property** with a **name** of 'dwell', and the **representation** used to describe the **action\_property** shall contain a **representation\_item** of type **measure\_representation\_item** and **time\_measure\_with\_unit**.

**WR10:** If the **description** of the **machining\_toolpath** is 'axis trajectory', the **machining\_toolpath** shall be the **definition** of exactly one **action\_property** with a **name** of 'axis commands', and the **representation** used to describe the **action\_property** shall contain at least one **representation\_item** of type **bounded\_curve**.

**WR11:** If the **description** of the **machining\_toolpath** is either 'approach lift path angle' or 'approach lift path tangent', the **machining\_toolpath** shall satisfy the following conditions:

- the **machining\_toolpath** shall be the **definition** of exactly one **action\_property** with a **name** of 'fix point', and the **representation** used to describe the **action\_property** shall contain a **representation\_item** of type **cartesian\_point**;
- the **machining\_toolpath** shall be the **definition** of at most one **action\_property** with a **name** of 'fix point direction', and the **representation** used to describe the **action\_property** shall contain a **representation\_item** of type **direction**.

**WR12:** If the **description** of the **machining\_toolpath** is 'approach lift path angle', the **machining\_toolpath** shall satisfy the following conditions:

- the **machining\_toolpath** shall be the **definition** of exactly one **action\_property** with a **name** of 'angle', and the **representation** used to describe the **action\_property** shall contain a **representation\_item** of type **measure\_representation\_item** and **plane\_angle\_measure\_with\_unit**;
- the **machining\_toolpath** shall be the **definition** of exactly one **action\_property** with a **name** of 'bend distance', and the **representation** used to describe the **action\_property** shall contain a **representation\_item** of type **measure\_representation\_item** and **length\_measure\_with\_unit**.

**WR13:** If the **description** of the **machining\_toolpath** is 'approach lift path tangent', the **machining\_toolpath** shall be the **definition** of exactly one **action\_property** with a **name** of 'radius', and the **representation** used to describe the **action\_property** shall contain a **representation\_item** of type **measure\_representation\_item** and **length\_measure\_with\_unit**.

**WR14:** If the **description** of the **machining\_toolpath** is 'cutter location trajectory', the **machining\_toolpath** shall satisfy the following conditions:

- the **machining\_toolpath** shall be the **definition** of exactly one **action\_property** with a **name** of 'basic curve', and the **representation** used to describe the **action\_property** shall contain a **representation\_item** of type **bounded\_curve**;
- the **machining\_toolpath** shall be the **definition** of at most one **action\_property** with a **name** of 'surface normal', and the **representation** used to describe the **action\_property** shall contain a **representation\_item** of type **bounded\_curve**;
- the **machining\_toolpath** shall be the **definition** of at most one **action\_property** with a **name** of 'tool axis', and the **representation** used to describe the **action\_property** shall contain a **representation\_item** of type **bounded\_curve**;

- the **machining\_toolpath** shall be the **definition** of at most one **action\_property** with a **name** of 'path maximum deviation', and the **representation** used to describe the **action\_property** shall contain a **representation\_item** of type **measure\_representation\_item** and **length\_measure\_with\_unit**;
- the **machining\_toolpath** shall be the **definition** of at most one **action\_property** with a **name** of 'tool axis maximum deviation', and the **representation** used to describe the **action\_property** shall contain a **representation\_item** of type **measure\_representation\_item** and **plane\_angle\_measure\_with\_unit**.

**WR15:** If the **description** of the **machining\_toolpath** is 'cutter contact trajectory', the **machining\_toolpath** shall satisfy the following conditions:

- the **machining\_toolpath** shall either be the **definition** of exactly one **action\_property** with a **name** of 'basic curve' with an associated **representation** that contains a **bounded\_pcurve**, or the **machining\_toolpath** shall be the **definition** of exactly one **action\_property** with a **name** of 'basic curve' with an associated **representation** that contains a **bounded\_curve** and exactly one **action\_property** with a **name** of 'surface normal' with an associated **representation** that contains a **bounded\_curve**;
- the **machining\_toolpath** shall be the **definition** of at most one **action\_property** with a **name** of 'tool axis', and the **representation** used to describe the **action\_property** shall contain a **representation\_item** of type **bounded\_curve**;
- the **machining\_toolpath** shall be the **definition** of at most one **action\_property** with a **name** of 'contact type', and the **representation** used to describe the **action\_property** shall contain a **representation\_item** of type **descriptive\_representation\_item** with a **description** of 'side' or 'front';
- the **machining\_toolpath** shall be the **definition** of at most one **action\_property** with a **name** of 'path maximum deviation', and the **representation** used to describe the **action\_property** shall contain a **representation\_item** of type **measure\_representation\_item** and **length\_measure\_with\_unit**;
- the **machining\_toolpath** shall be the **definition** of at most one **action\_property** with a **name** of 'tool axis maximum deviation', and the **representation** used to describe the **action\_property** shall contain a **representation\_item** of type **measure\_representation\_item** and **plane\_angle\_measure\_with\_unit**.

**WR16:** If the **description** of the **machining\_toolpath** is 'axis trajectory', 'cutter location trajectory', or 'cutter contact trajectory', the **machining\_toolpath** shall satisfy the following conditions:

- the **machining\_toolpath** shall be the **definition** of at most one **action\_property** with a **name** of 'material removal depth', and the **representation** used to describe the **action\_property** shall contain a **representation\_item** either of type **measure\_representation\_item** and **length\_measure\_with\_unit**, or of type **bounded\_curve**;
- the **machining\_toolpath** shall be the **definition** of at most one **action\_property** with a **name** of 'material removal overcut', and the **representation** used to describe the **action\_property** shall



contain a **representation\_item** either of type **measure\_representation\_item** and **length\_measure\_with\_unit**, or of type **bounded\_curve**;

- the **machining\_toolpath** shall be the **definition** of at most one **action\_property** with a **name** of 'material removal total volume', and the **representation** used to describe the **action\_property** shall contain a **representation\_item** of type **measure\_representation\_item**.

### 5.2.3.1.77 machining\_toolpath\_sequence\_relationship

A **machining\_toolpath\_sequence\_relationship** is a type of **sequential\_method** that represents use of a Toolpath as an element of a sequence in an Operation or strategy. See the ARM definitions for Workpiece\_setup in ISO 14649-10 and Along\_path in ISO 14649-11 for more information.

EXPRESS specification:

```
*)
ENTITY machining_toolpath_sequence_relationship
  SUBTYPE OF (sequential_method);
END_ENTITY;
(*
```

### 5.2.3.1.78 machining\_toolpath\_speed\_profile\_representation

A **machining\_toolpath\_speed\_profile\_representation** is a type of **representation** that represents the variation of feedrate as the machine axes move through a tool path. See the ARM definition for Toolpath\_speedprofile in ISO 14649-10 for more information.

EXPRESS specification:

```
*)
ENTITY machining_toolpath_speed_profile_representation
  SUBTYPE OF (representation);
  WHERE
    WR1: (1 = SIZEOF (QUERY ( it <* SELF.items |
      ( (('INTEGRATED_CNC_SCHEMA.B_SPLINE_CURVE'
        IN TYPEOF(it))) OR

      (('INTEGRATED_CNC_SCHEMA.DESRIPTIVE_REPRESENTATION_ITEM'
        IN TYPEOF(it)) AND
        (it.description IN ['rapid'])) OR

      ((SIZEOF([
        'INTEGRATED_CNC_SCHEMA.MEASURE_REPRESENTATION_ITEM',
        'INTEGRATED_CNC_SCHEMA.RATIO_MEASURE_WITH_UNIT'] *
        TYPEOF(it)) = 2))
    )
  ));
END_ENTITY;
(*
```

Formal propositions:

**WR1:** The **items** set shall contain exactly one **representation\_item** that is either of type **b\_spline\_curve**, of type **descriptive\_representation\_item** with a **description** of 'side', or of type **measure\_representation\_item** and **ratio\_measure\_with\_unit**.

**5.2.3.1.79 machining\_touch\_probing**

A **machining\_touch\_probing** is a type of **machining\_process\_executable** and **machining\_operation** that represents a measurement step in a machining process. See the ARM definitions for **Touch\_probing** and subtypes in ISO 14649-10 for more information.

EXPRESS specification:

\*)

```

ENTITY machining_touch_probing
  SUBTYPE OF (machining_process_executable, machining_operation);
  WHERE
  WR1: (SELF.description IN ['tool length probing', 'tool radius probing',
    'workpiece probing', 'workpiece complete probing']);

  WR2: ((verify_required_action_property      (SELF, 'security plane')) AND
    (verify_rep_item_for_action_property     (SELF, 'security plane',
    ['INTEGRATED_CNC_SCHEMA.ELEMENTARY_SURFACE'])));

  WR3: ((verify_required_action_property      (SELF, 'measured offset')) AND
    (verify_rep_item_for_action_property     (SELF, 'measured offset',
    ['INTEGRATED_CNC_SCHEMA.EXPRESSION_REPRESENTATION_ITEM',
    'INTEGRATED_CNC_SCHEMA.NUMERIC_VARIABLE'])));

  WR4: NOT (SELF.description = 'workpiece probing') OR
    ((verify_required_action_property      (SELF, 'start position')) AND
    (verify_rep_item_for_action_property     (SELF, 'start position',
    ['INTEGRATED_CNC_SCHEMA.AXIS2_PLACEMENT_3D'])) AND

    (1 = SIZEOF (QUERY (act < *
      USEDIN (SELF, 'INTEGRATED_CNC_SCHEMA.ACTION.CHOSEN_METHOD') |
      (act.name = 'workpiece probing')))) AND
    (0 = SIZEOF (QUERY (act < *
      USEDIN (SELF, 'INTEGRATED_CNC_SCHEMA.ACTION.CHOSEN_METHOD') |
      (act.name = 'workpiece probing') AND NOT
      ('INTEGRATED_CNC_SCHEMA.PRODUCT_DEFINITION_PROCESS'
      IN TYPEOF (act)))))) AND

    (verify_required_action_property      (SELF, 'direction')) AND
    (verify_rep_item_for_action_property     (SELF, 'direction',
    ['INTEGRATED_CNC_SCHEMA.DIRECTION'])) AND

    (verify_required_action_property      (SELF, 'expected value')) AND
    (verify_rep_item_for_action_property     (SELF, 'expected value',
    ['INTEGRATED_CNC_SCHEMA.LENGTH_MEASURE_WITH_UNIT',
    'INTEGRATED_CNC_SCHEMA.MEASURE_REPRESENTATION_ITEM',

```

```

        'INTEGRATED_CNC_SCHEMA.QUALIFIED_REPRESENTATION_ITEM'])) AND

    (verify_required_action_property      (SELF, 'probe'))
);

WR5: NOT (SELF.description = 'workpiece complete probing') OR
((1 = SIZEOF (QUERY (act <*
    USEDIN (SELF, 'INTEGRATED_CNC_SCHEMA.ACTION.CHOSEN_METHOD') |
    (act.name = 'workpiece complete probing')))) AND
(0 = SIZEOF (QUERY (act <*
    USEDIN (SELF, 'INTEGRATED_CNC_SCHEMA.ACTION.CHOSEN_METHOD') |
    (act.name = 'workpiece complete probing') AND NOT
    ('INTEGRATED_CNC_SCHEMA.PRODUCT_DEFINITION_PROCESS'
    IN TYPEOF (act)))))) AND

    (verify_required_action_property      (SELF, 'probing distance')) AND
    (verify_rep_item_for_action_property   (SELF, 'probing distance',
    ['INTEGRATED_CNC_SCHEMA.LENGTH_MEASURE_WITH_UNIT',
    'INTEGRATED_CNC_SCHEMA.MEASURE_REPRESENTATION_ITEM',
    'INTEGRATED_CNC_SCHEMA.QUALIFIED_REPRESENTATION_ITEM'])) AND

    (verify_required_action_property      (SELF, 'probe')) AND

    (verify_required_action_property      (SELF, 'computed offset')) AND
    (verify_rep_type_for_action_property   (SELF, 'computed offset',
    ['INTEGRATED_CNC_SCHEMA.MACHINING_OFFSET_VECTOR_REPRESENTATION']))
);

WR6: NOT (SELF.description IN ['tool length probing',
    'tool radius probing']) OR
((verify_required_action_property      (SELF, 'offset')) AND
(verify_rep_item_for_action_property   (SELF, 'offset',
    ['INTEGRATED_CNC_SCHEMA.CARTESIAN_POINT'])) AND

    (verify_required_action_property      (SELF, 'maximum wear')) AND
    (verify_length_measure_action_property (SELF, 'maximum wear')) AND

    (1 = SIZEOF (QUERY (mt <*
    USEDIN (SELF, 'INTEGRATED_CNC_SCHEMA.ACTION_RESOURCE.USAGE') |
    ('INTEGRATED_CNC_SCHEMA.MACHINING_TOOL' in TYPEOF(mt))))
);
END_ENTITY;
(*

```

### Formal propositions:

**WR1:** The **description** of the **machining touch probing** shall be either 'workpiece probing', 'workpiece complete probing', 'tool length probing', or 'tool radius probing'.

**WR2:** The **machining touch probing** shall be the **definition** of exactly one **action\_property** with a **name** of 'security plane', and the **representation** used to describe the **action\_property** shall contain a **representation\_item** of type **elementary\_surface**.

**WR3:** The **machining\_touch\_probing** shall be the **definition** of exactly one **action\_property** with a **name** of 'measured offset', and the **representation** used to describe the **action\_property** shall contain a **representation\_item** of type **expression\_representation\_item** and **numeric\_variable**.

**WR4:** If the **description** of the **machining\_touch\_probing** is 'workpiece probing', the **machining\_touch\_probing** shall satisfy the following conditions:

- the **machining\_touch\_probing** shall be the **definition** of exactly one **action\_property** with a **name** of 'start position', and the **representation** used to describe the **action\_property** shall contain a **representation\_item** of type **axis2\_placement\_3d**;
- the **machining\_touch\_probing** shall be the **chosen\_method** of exactly one **product\_definition\_process** with a **name** of 'workpiece probing';
- the **machining\_touch\_probing** shall be the **definition** of exactly one **action\_property** with a **name** of 'direction', and the **representation** used to describe the **action\_property** shall contain a **representation\_item** of type **direction**;
- the **machining\_touch\_probing** shall be the **definition** of exactly one **action\_property** with a **name** of 'expected value', and the **representation** used to describe the **action\_property** shall contain a **representation\_item** of type **length\_measure\_with\_unit**, **measure\_representation\_item**, and **qualified\_representation\_item**;
- the **machining\_touch\_probing** shall be the **definition** of exactly one **action\_property** with a **name** of 'probe'.

**WR5:** If the **description** of the **machining\_touch\_probing** is 'workpiece complete probing', the **machining\_touch\_probing** shall satisfy the following conditions:

- the **machining\_touch\_probing** shall be the **chosen\_method** of exactly one **product\_definition\_process** with a **name** of 'workpiece complete probing';
- the **machining\_touch\_probing** shall be the **definition** of exactly one **action\_property** with a **name** of 'probing distance', and the **representation** used to describe the **action\_property** shall contain a **representation\_item** of type **length\_measure\_with\_unit**, **measure\_representation\_item**, and **qualified\_representation\_item**;
- the **machining\_touch\_probing** shall be the **definition** of exactly one **action\_property** with a **name** of 'probe';
- the **machining\_touch\_probing** shall be the **definition** of exactly one **action\_property** with a **name** of 'computed offset', and the **representation** used to describe the **action\_property** shall be of type **machining\_offset\_vector\_representation**.

**WR6:** If the **description** of the **machining\_touch\_probing** is either 'tool length probing' or 'tool radius probing', the **machining\_touch\_probing** shall satisfy the following conditions:

- the **machining\_touch\_probing** shall be the **definition** of exactly one **action\_property** with a **name** of 'offset', and the **representation** used to describe the **action\_property** shall contain a **representation\_item** of type **cartesian\_point**;
- the **machining\_touch\_probing** shall be the **definition** of exactly one **action\_property** with a **name** of 'maximum wear', and the **representation** used to describe the **action\_property** shall contain a **representation\_item** of type **length\_measure\_with\_unit** and **measure\_representation\_item**;
- the **machining\_touch\_probing** shall appear in the **usage** set of exactly one **machining\_tool**.

### 5.2.3.1.80 machining\_workingstep

A **machining\_workingstep** is a type of **machining\_process\_executable** that represents a step in a machining process. See the ARM definition for **Machining\_workingstep** in ISO 14649-10 and **Turning\_workingstep** in ISO 14649-12 for more information.

#### EXPRESS specification:

```

*)
ENTITY machining_workingstep
  SUBTYPE OF (machining_process_executable);
  WHERE
  WR1: ((verify_optional_action_property (SELF, 'security plane')) AND
        (verify_rep_item_for_action_property (SELF, 'security plane',
        ['INTEGRATED_CNC_SCHEMA.ELEMENTARY_SURFACE'])));

  WR2: NOT (SELF.description = 'machining') OR
        ((verify_required_relatng_amr (SELF,
        ['INTEGRATED_CNC_SCHEMA.MACHINING_FEATURE_RELATIONSHIP'])) AND
        (verify_related_type_for_amr (SELF,
        ['INTEGRATED_CNC_SCHEMA.MACHINING_FEATURE_RELATIONSHIP'],
        ['INTEGRATED_CNC_SCHEMA.MACHINING_FEATURE_PROCESS'])) AND

        (verify_related_type_for_amr (SELF,
        ['INTEGRATED_CNC_SCHEMA.MACHINING_FINAL_FEATURE_RELATIONSHIP'],
        ['INTEGRATED_CNC_SCHEMA.MACHINING_FEATURE_PROCESS'])) AND

        (verify_required_relatng_amr (SELF,
        ['INTEGRATED_CNC_SCHEMA.MACHINING_OPERATION_RELATIONSHIP'])) AND
        (verify_related_type_for_amr (SELF,
        ['INTEGRATED_CNC_SCHEMA.MACHINING_OPERATION_RELATIONSHIP'],
        ['INTEGRATED_CNC_SCHEMA.MACHINING_OPERATION']))
        );

  WR3: NOT (SELF.description = 'turning') OR
        ((2 <= get_count_of_relatng_amr (SELF,
        ['INTEGRATED_CNC_SCHEMA.MACHINING_FEATURE_SEQUENCE_RELATIONSHIP']))
  AND
        (verify_related_type_for_amr (SELF,
        ['INTEGRATED_CNC_SCHEMA.MACHINING_FEATURE_SEQUENCE_RELATIONSHIP'],
        ['INTEGRATED_CNC_SCHEMA.MACHINING_FEATURE_PROCESS'])) AND

```

```

    (verify_required_relatng_amr (SELF,
      ['INTEGRATED_CNC_SCHEMA.MACHINING_OPERATION_RELATIONSHIP'])) AND
    (verify_related_type_for_amr (SELF,
      ['INTEGRATED_CNC_SCHEMA.MACHINING_OPERATION_RELATIONSHIP'],
      ['INTEGRATED_CNC_SCHEMA.TURNING_TYPE_OPERATION']))
  );

  WR4: NOT (SELF.description IN ['machining', 'turning']) OR
    (verify_optional_in_process_geometry (SELF));

  WR5: ((verify_optional_action_property (SELF, 'toolpath orientation')) AND
    (verify_rep_item_for_action_property (SELF, 'toolpath orientation',
      ['INTEGRATED_CNC_SCHEMA.AXIS2_PLACEMENT_3D'])));

END_ENTITY;
(*

```

Formal propositions:

**WR1:** The **machining\_workingstep** shall be the **definition** of at most one **action\_property** with a **name** of 'security plane', and the **representation** used to describe the **action\_property** shall contain a **representation\_item** of type **elementary\_surface**.

**WR2:** If the **description** of the **machining\_workingstep** is 'machining', the **machining\_workingstep** shall satisfy the following conditions:

- **machining\_workingstep** shall be the **relating\_method** of exactly one **machining\_feature\_relationship**, in which the **related\_method** is of type **machining\_feature\_process**;
- **machining\_workingstep** shall be the **relating\_method** of zero or more **machining\_final\_feature\_relationship**, in which the **related\_method** is of type **machining\_feature\_process**;
- **machining\_workingstep** shall be the **relating\_method** of exactly one **machining\_operation\_relationship**, in which the **related\_method** is of type **machining\_operation**.

**WR3:** If the **description** of the **machining\_workingstep** is 'turning', the **machining\_workingstep** shall satisfy the following conditions:

- **machining\_workingstep** shall be the **relating\_method** of two or more instances of **machining\_feature\_sequence\_relationship**, in which the **related\_method** is of type **machining\_feature\_process**;
- **machining\_workingstep** shall be the **relating\_method** of exactly one **machining\_operation\_relationship**, in which the **related\_method** is of type **turning\_type\_operation**.

**WR4:** If the **description** of the **machining\_workingstep** is either 'machining' or 'turning', the **machining\_workingstep** shall satisfy the conditions tested by the function **verify\_optional\_in\_process\_geometry**. Refer to the definition of the function **verify\_optional\_in\_process\_geometry** for more information.

**WR5:** The **machining\_workingstep** shall be the **definition** of at most one **action\_property** with a **name** of 'toolpath orientation', and the **representation** used to describe the **action\_property** shall contain a **representation\_item** of type **axis2\_placement\_3d**.

Informal propositions:

**IP1:** If the **description** of the **machining\_workingstep** is 'turning', all **sequential\_method** instances with a **name** of 'process feature' which refer to the **machining\_workingstep** through the **related** attribute shall have unique **sequence\_position** values.

### 5.2.3.1.81 machining\_workplan

A **machining\_workplan** is a type of **machining\_process\_executable** that represents a sequence of steps in a machining process. See the ARM definition for **Manufacturing\_feature** in ISO 14649-10 for more information.

EXPRESS specification:

```

*)
ENTITY machining_workplan
  SUBTYPE OF (machining_process_executable);
  WHERE
    WR1: (1 <= get_count_of_relating_amr (SELF,
      ['INTEGRATED_CNC_SCHEMA.MACHINING_PROCESS_SEQUENCE_RELATIONSHIP']))
AND
  (verify_related_type_for_amr (SELF,
    ['INTEGRATED_CNC_SCHEMA.MACHINING_PROCESS_SEQUENCE_RELATIONSHIP'],
    ['INTEGRATED_CNC_SCHEMA.MACHINING_PROCESS_EXECUTABLE']));

    WR2: (verify_optional_action_property (SELF, 'channel'));

    WR3: (1 >= SIZEOF (QUERY (act < *
      USEDIN (SELF, 'INTEGRATED_CNC_SCHEMA.ACTION.CHOSEN_METHOD') |
      (act.name = 'setup')))) AND
      (0 = SIZEOF (QUERY (act < *
      USEDIN (SELF, 'INTEGRATED_CNC_SCHEMA.ACTION.CHOSEN_METHOD') |
      (act.name = 'setup') AND NOT
      ('INTEGRATED_CNC_SCHEMA.PRODUCT_DEFINITION_PROCESS' IN TYPEOF (act))
      ))));

    WR4: (verify_optional_in_process_geometry (SELF));
END_ENTITY;
(*

```

Formal propositions:

**WR1:** The **machining\_workplan** shall be the **relating\_method** of at least one **machining\_process\_sequence\_relationship**, in which the **related\_method** is of type **machining\_process\_executable**.

**WR2:** The **machining\_workplan** shall be the **definition** of at most one **action\_property** with a **name** of 'channel'.

**WR3:** The **machining\_workplan** shall be the **chosen\_method** of at most one **product\_definition\_process** with a **name** of 'setup'.

**WR4:** The **machining\_workplan** shall satisfy the conditions tested by the function **verify\_optional\_in\_process\_geometry**. Refer to the definition of the function **verify\_optional\_in\_process\_geometry** for more information.

Informal propositions:

**IP1:** All **machining\_process\_sequence\_relationship** instances which refer to the same **machining\_workplan** through the **relating\_method** attribute shall have unique **sequence\_position** values.

### 5.2.3.1.82 milling\_type\_operation

A **milling\_type\_operation** is a type of **machining\_operation** that represents the details of a milling step of a machining process. See the ARM definitions for **Milling\_type\_operation** and subtypes in ISO 14649-11 for more information.

EXPRESS specification:

```

*)
ENTITY milling_type_operation
  SUBTYPE OF (machining_operation);
  WHERE
  WR1: (verify_optional_action_property (SELF, 'overcut length')) AND
        (verify_length_measure_action_property (SELF, 'overcut length'));

  WR2: ((verify_optional_relating_amr_with_name (SELF, 'approach',
        ['INTEGRATED_CNC_SCHEMA.MACHINING_STRATEGY_RELATIONSHIP'])) AND
        (verify_related_type_for_amr_with_name (SELF, 'approach',
        ['INTEGRATED_CNC_SCHEMA.MACHINING_STRATEGY_RELATIONSHIP'],
        ['INTEGRATED_CNC_SCHEMA.MACHINING_APPROACH_RETRACT_STRATEGY']))
        );

  WR3: ((verify_optional_relating_amr_with_name (SELF, 'retract',
        ['INTEGRATED_CNC_SCHEMA.MACHINING_STRATEGY_RELATIONSHIP'])) AND
        (verify_related_type_for_amr_with_name (SELF, 'retract',
        ['INTEGRATED_CNC_SCHEMA.MACHINING_STRATEGY_RELATIONSHIP'],
        ['INTEGRATED_CNC_SCHEMA.MACHINING_APPROACH_RETRACT_STRATEGY']))
        );

  WR4: ((verify_optional_relating_amr_with_name (SELF, 'machining',
        ['INTEGRATED_CNC_SCHEMA.MACHINING_STRATEGY_RELATIONSHIP'])) AND
        (verify_related_type_for_amr_with_name (SELF, 'machining',
        ['INTEGRATED_CNC_SCHEMA.MACHINING_STRATEGY_RELATIONSHIP'],
        ['INTEGRATED_CNC_SCHEMA.MILLING_TYPE_STRATEGY']))
        );
END_ENTITY;
(*

```



Formal propositions:

**WR1:** The **milling\_type\_operation** shall be the **definition** of at most one **action\_property** with a **name** of 'overcut length', and the **representation** used to describe the **action\_property** shall contain a **representation\_item** of type **measure\_representation\_item** and **length\_measure\_with\_unit**

**WR2:** The **milling\_type\_operation** shall be the **relating\_method** of at most one **machining\_strategy\_relationship** with a **name** of 'approach', in which the **related\_method** shall be of type **machining\_approach\_retract\_strategy**.

**WR3:** The **milling\_type\_operation** shall be the **relating\_method** of at most one **machining\_strategy\_relationship** with a **name** of 'retract', in which the **related\_method** shall be of type **machining\_approach\_retract\_strategy**.

**WR4:** The **milling\_type\_operation** shall be the **relating\_method** of at most one **machining\_strategy\_relationship** with a **name** of 'machining', in which the **related\_method** shall be of type **milling\_type\_strategy**.

### 5.2.3.1.83 milling\_type\_strategy

A **milling\_type\_strategy** is a type of **machining\_strategy** that represents the approach used to determine the motion of the cutting tool during a milling operation. See the ARM definitions for **Two5D\_milling\_strategy**, **Freeform\_strategy**, and subtypes in ISO 14649-11 for more information.

EXPRESS specification:

\*)

```

ENTITY milling_type_strategy
  SUBTYPE OF (machining_strategy);
  WHERE
    WR1: NOT (SELF.description IN ['bidirectional', 'bidirectional contour',
      'center milling', 'contour bidirectional', 'contour parallel',
      'contour spiral', 'explicit', 'unidirectional']) OR
      ((verify_optional_action_property      (SELF, 'overlap ratio')) AND
      (verify_ratio_measure_action_property  (SELF, 'overlap ratio')) AND

      (verify_optional_action_property      (SELF, 'multiple passes')) AND
      (verify_enumeration_action_property   (SELF, 'multiple passes',
        ['multiple passes allowed', 'multiple passes not allowed'])) );

    WR2: NOT (SELF.description = 'bidirectional') OR
      ((verify_optional_action_property      (SELF, 'feed direction')) AND
      (verify_rep_item_for_action_property   (SELF, 'feed direction',
        ['INTEGRATED_CNC_SCHEMA.DIRECTION'])) AND

      (verify_optional_action_property      (SELF, 'stepover direction')) AND
      (verify_enumeration_action_property   (SELF, 'stepover direction',
        ['left', 'right'])) AND

      (verify_optional_action_property      (SELF, 'connection strategy')) AND
      (verify_enumeration_action_property   (SELF, 'connection strategy',

```

```

        ['straight line', 'lift shift plunge', 'degouge', 'loop back'])) );

WR3: NOT (SELF.description IN ['bidirectional contour',
        'contour bidirectional']) OR
((verify_optional_action_property      (SELF, 'feed direction')) AND
 (verify_rep_item_for_action_property  (SELF, 'feed direction',
        ['INTEGRATED_CNC_SCHEMA.DIRECTION'])) AND

 (verify_optional_action_property      (SELF, 'stepover direction')) AND
 (verify_enumeration_action_property  (SELF, 'stepover direction',
        ['left', 'right'])) AND

 (verify_optional_action_property      (SELF, 'rotation direction')) AND
 (verify_enumeration_action_property  (SELF, 'rotation direction',
        ['clockwise', 'counterclockwise'])) AND

 (verify_optional_action_property      (SELF, 'spiral cutmode')) AND
 (verify_enumeration_action_property  (SELF, 'spiral cutmode',
        ['climb', 'conventional']))) );

WR4: NOT (SELF.description IN ['contour parallel', 'contour spiral']) OR
((verify_optional_action_property      (SELF, 'rotation direction')) AND
 (verify_enumeration_action_property  (SELF, 'rotation direction',
        ['clockwise', 'counterclockwise'])) AND

 (verify_optional_action_property      (SELF, 'cutmode')) AND
 (verify_enumeration_action_property  (SELF, 'cutmode',
        ['climb', 'conventional']))) );

WR5: NOT (SELF.description = 'unidirectional') OR
((verify_optional_action_property      (SELF, 'feed direction')) AND
 (verify_rep_item_for_action_property  (SELF, 'feed direction',
        ['INTEGRATED_CNC_SCHEMA.DIRECTION'])) AND

 (verify_optional_action_property      (SELF, 'cutmode')) AND
 (verify_enumeration_action_property  (SELF, 'cutmode',
        ['climb', 'conventional']))) );
END_ENTITY;
(*

```

### Formal propositions:

**WR1:** If the **description** of the **milling\_type\_strategy** is either 'bidirectional', 'bidirectional contour', 'center milling', 'contour bidirectional', 'contour parallel', 'contour spiral', 'explicit', or 'unidirectional', the **milling\_type\_strategy** shall satisfy the following conditions:

- the **milling\_type\_strategy** shall be the **definition** of at most one **action\_property** with a **name** of 'overlap ratio', and the **representation** used to describe the **action\_property** shall contain a **representation\_item** of type **measure\_representation\_item** and **ratio\_measure\_with\_unit**;
- the **milling\_type\_strategy** shall be the **definition** of at most one **action\_property** with a **name** of 'multiple passes', and the **representation** used to describe the **action\_property** shall contain a

**representation\_item** of type **descriptive\_representation\_item** with a **description** of 'multiple passes allowed' or 'multiple passes not allowed'.

**WR2:** If the **description** of the **milling\_type\_strategy** is 'bidirectional', the **milling\_type\_strategy** shall satisfy the following conditions:

- the **milling\_type\_strategy** shall be the **definition** of at most one **action\_property** with a **name** of 'feed direction', and the **representation** used to describe the **action\_property** shall contain a **representation\_item** of type **direction**;
- the **milling\_type\_strategy** shall be the **definition** of at most one **action\_property** with a **name** of 'stepover direction', and the **representation** used to describe the **action\_property** shall contain a **representation\_item** of type **descriptive\_representation\_item** with a **description** of 'left' or 'right';
- the **milling\_type\_strategy** shall be the **definition** of at most one **action\_property** with a **name** of 'connection strategy', and the **representation** used to describe the **action\_property** shall contain a **representation\_item** of type **descriptive\_representation\_item** with a **description** of 'straight line', 'lift shift plunge', 'degouge', or 'loop back'.

**WR3:** If the **description** of the **milling\_type\_strategy** is either 'bidirectional contour' or 'contour bidirectional', the **milling\_type\_strategy** shall satisfy the following conditions:

- the **milling\_type\_strategy** shall be the **definition** of at most one **action\_property** with a **name** of 'feed direction', and the **representation** used to describe the **action\_property** shall contain a **representation\_item** of type **direction**;
- the **milling\_type\_strategy** shall be the **definition** of at most one **action\_property** with a **name** of 'stepover direction', and the **representation** used to describe the **action\_property** shall contain a **representation\_item** of type **descriptive\_representation\_item** with a **description** of 'left' or 'right';
- the **milling\_type\_strategy** shall be the **definition** of at most one **action\_property** with a **name** of 'rotation direction', and the **representation** used to describe the **action\_property** shall contain a **representation\_item** of type **descriptive\_representation\_item** with a **description** of 'clockwise' or 'counterclockwise';
- the **milling\_type\_strategy** shall be the **definition** of at most one **action\_property** with a **name** of 'spiral cutmode', and the **representation** used to describe the **action\_property** shall contain a **representation\_item** of type **descriptive\_representation\_item** with a **description** of 'climb' or 'conventional'.

**WR4:** If the **description** of the **milling\_type\_strategy** is either 'contour parallel' or 'contour spiral', the **milling\_type\_strategy** shall satisfy the following conditions:

- the **milling\_type\_strategy** shall be the **definition** of at most one **action\_property** with a **name** of 'rotation direction', and the **representation** used to describe the **action\_property** shall contain a **representation\_item** of type **descriptive\_representation\_item** with a **description** of 'clockwise' or 'counterclockwise';

— the **milling\_type\_strategy** shall be the **definition** of at most one **action\_property** with a **name** of 'cutmode', and the **representation** used to describe the **action\_property** shall contain a **representation\_item** of type **descriptive\_representation\_item** with a **description** of 'climb' or 'conventional'.

**WR5:** If the **description** of the **milling\_type\_strategy** is 'unidirectional', the **milling\_type\_strategy** shall satisfy the following conditions:

— the **milling\_type\_strategy** shall be the **definition** of at most one **action\_property** with a **name** of 'feed direction', and the **representation** used to describe the **action\_property** shall contain a **representation\_item** of type **direction**;

— the **milling\_type\_strategy** shall be the **definition** of at most one **action\_property** with a **name** of 'cutmode', and the **representation** used to describe the **action\_property** shall contain a **representation\_item** of type **descriptive\_representation\_item** with a **description** of 'climb' or 'conventional'.

### 5.2.3.1.84 ngon\_shape\_representation

An **ngon\_shape\_representation** specifies representation of a shape that is a volume defined as a ngon area of a defined length. The enclosed area is defined by three or more straight sides.

**NOTE** This definition has been harmonized with the equivalent definition in ISO 10303-224.

#### EXPRESS specification:

\*)

```

ENTITY ngon_shape_representation
  SUBTYPE OF (shape_representation_with_parameters);
  WHERE
    WR1: (SIZEOF(SELF.items) = 5);
    WR2: (SIZEOF(QUERY ( it <* SELF.items |
      (('INTEGRATED_CNC_SCHEMA.PLACEMENT'
      IN TYPEOF(it)) AND (it.name = 'orientation'))) ) = 1);
    WR3: (SIZEOF(QUERY ( it <* SELF.items |
      ((SIZEOF([
        'INTEGRATED_CNC_SCHEMA.MEASURE_REPRESENTATION_ITEM',
        'INTEGRATED_CNC_SCHEMA.LENGTH_MEASURE_WITH_UNIT'] *
        TYPEOF(it)) = 2) AND (it.name = 'length'))) ) = 1);
    WR4: (SIZEOF(QUERY ( it <* SELF.items |
      ((SIZEOF([
        'INTEGRATED_CNC_SCHEMA.MEASURE_REPRESENTATION_ITEM',
        'INTEGRATED_CNC_SCHEMA.LENGTH_MEASURE_WITH_UNIT'] *
        TYPEOF(it)) = 2) AND (it.name = 'corner radius'))) ) = 1);
    WR5: SIZEOF (QUERY (it <* SELF.items |
      (SIZEOF
      (['INTEGRATED_CNC_SCHEMA.MEASURE_REPRESENTATION_ITEM',
        'INTEGRATED_CNC_SCHEMA.LENGTH_MEASURE_WITH_UNIT'] *
        TYPEOF (it)) = 2) AND
      (it.name IN ['circumscribed diameter','diameter across flats'])) = 1;
    WR6: (SIZEOF(QUERY ( it <* SELF.items |

```

```

      (('INTEGRATED_CNC_SCHEMA.MEASURE_REPRESENTATION_ITEM'
      IN TYPEOF(it)) AND
      ('INTEGRATED_CNC_SCHEMA.COUNT_MEASURE'
      IN TYPEOF(it\measure_with_unit.value_component)) AND
      (it.name = 'number of sides')) ) = 1);
END_ENTITY; -- ngon_shape_representation
(*)

```

#### Formal propositions:

**WR1:** The **ngon\_shape\_representation** shall contain exactly five **representation\_items** in its set of **items**.

**WR2:** One of the **representation\_items** used for the implicit representation of a **ngon\_shape\_representation** shall be of type **placement** with a **name** of 'orientation'.

**WR3:** One of the **representation\_items** used for the implicit representation of a **ngon\_shape\_representation** shall be of type **measure\_representation\_item** and **length\_measure\_with\_unit** with a **name** of 'length'.

**WR4:** One of the **representation\_items** used for the implicit representation of a **ngon\_shape\_representation** shall be of type **measure\_representation\_item** and **length\_measure\_with\_unit** with a **name** of 'corner radius'.

**WR5:** One of the **representation\_items** used for the implicit representation of a **ngon\_shape\_representation** shall be of type **measure\_representation\_item** and **length\_measure\_with\_unit** with a **name** of 'circumscribed diameter' or 'diameter across flats'.

**WR6:** One of the **representation\_items** used for the implicit representation of a **ngon\_shape\_representation** shall be of type **measure\_representation\_item** with a **value\_component** of type **count\_measure** and a **name** of 'number of sides'.

#### Informal propositions:

**IP1:** The location of the **ngon\_shape\_representation** shall be defined at the centre of the enclosed area.

**IP2:** The **ngon\_shape\_representation** shall be defined with the enclosed area in the X-Y plane with one of the sides of the ngon parallel to the X direction intersecting the negative Y axis. The length is along the Z direction.

### 5.2.3.1.85 placed\_datum\_target\_feature

A **placed\_datum\_target\_feature** is a type of **datum\_target** that represents the implicit definition of a datum target for tolerancing purposes.

NOTE This definition has been harmonized with the equivalent definitions in ISO 10303-214, ISO 10303-224, and ISO 10303-1050.

EXPRESS specification:

```

*)
ENTITY placed_datum_target_feature
  SUBTYPE OF (datum_target);
  WHERE
  WR1 : (SELF.description IN ['point','line','rectangle','circle']);
  WR2 : (SIZEOF(QUERY ( pd <* USEDIN(SELF,
    'INTEGRATED_CNC_SCHEMA.PROPERTY_DEFINITION.DEFINITION') |
    (NOT (SIZEOF(QUERY ( pdr <* USEDIN(pd,
      'INTEGRATED_CNC_SCHEMA.' +
      'PROPERTY_DEFINITION_REPRESENTATION.DEFINITION') |
      (('INTEGRATED_CNC_SCHEMA.' +
      'SHAPE_REPRESENTATION_WITH_PARAMETERS')
      IN TYPEOF(pdr.used_representation)) ) = 1)) ) = 0);
  WR3 : (SIZEOF(QUERY ( pd <* USEDIN(SELF,
    'INTEGRATED_CNC_SCHEMA.PROPERTY_DEFINITION.DEFINITION') |
    (NOT (SIZEOF(QUERY ( dtm_rep <* QUERY ( pdr <* USEDIN(pd,
      'INTEGRATED_CNC_SCHEMA.' +
      'PROPERTY_DEFINITION_REPRESENTATION.DEFINITION') |
      (('INTEGRATED_CNC_SCHEMA.' +
      'SHAPE_REPRESENTATION_WITH_PARAMETERS')
      IN TYPEOF(pdr.used_representation)) ) |
      (NOT (SIZEOF(QUERY ( it <* dtm_rep.used_representation.items |
        (('INTEGRATED_CNC_SCHEMA.PLACEMENT'
        IN TYPEOF(it)) AND (it.name = 'orientation')) ) = 1)) ) =
        0)) ) = 0);
  WR4 : ((NOT (SELF.description = 'point')) OR
    (SIZEOF(QUERY ( pd <* USEDIN(SELF,
      'INTEGRATED_CNC_SCHEMA.PROPERTY_DEFINITION.DEFINITION') |
      (NOT (SIZEOF(QUERY ( dtm_rep <*
      QUERY ( pdr <* USEDIN(pd, 'INTEGRATED_CNC_SCHEMA.' +
      'PROPERTY_DEFINITION_REPRESENTATION.DEFINITION') |
      (('INTEGRATED_CNC_SCHEMA.' +
      'SHAPE_REPRESENTATION_WITH_PARAMETERS')
      IN TYPEOF(pdr.used_representation)) ) |
      (NOT (SIZEOF(dtm_rep.used_representation.items) = 1)) ) =
      0)) ) = 0));
  WR5 : ((NOT (SELF.description IN ['line','circle'])) OR
    (SIZEOF(QUERY ( pd <* USEDIN(SELF,
      'INTEGRATED_CNC_SCHEMA.PROPERTY_DEFINITION.DEFINITION') |
      (NOT (SIZEOF(QUERY ( dtm_rep <* QUERY ( pdr <* USEDIN(pd,
        'INTEGRATED_CNC_SCHEMA.' +
        'PROPERTY_DEFINITION_REPRESENTATION.DEFINITION') |
        (('INTEGRATED_CNC_SCHEMA.' +
        'SHAPE_REPRESENTATION_WITH_PARAMETERS')
        IN TYPEOF(pdr.used_representation)) ) |
        (NOT (SIZEOF(dtm_rep.used_representation.items) = 2)) ) =
        0)) ) = 0));
  WR6 : ((NOT (SELF.description = 'rectangle')) OR
    (SIZEOF(QUERY ( pd <* USEDIN(SELF,
      'INTEGRATED_CNC_SCHEMA.PROPERTY_DEFINITION.DEFINITION') |
      (NOT (SIZEOF(QUERY ( dtm_rep <* QUERY ( pdr <* USEDIN(pd,

```

```

'INTEGRATED_CNC_SCHEMA.' +
'PROPERTY_DEFINITION_REPRESENTATION.DEFINITION') |
(('INTEGRATED_CNC_SCHEMA.' +
'SHAPE_REPRESENTATION_WITH_PARAMETERS')
IN TYPEOF(pdr.used_representation)) ) |
(NOT (SIZEOF(dtm_rep.used_representation.items) = 3)) )
= 0)) )) = 0));
WR7 : ((NOT (SELF.description = 'circle')) OR
(SIZEOF(QUERY ( pd <* USEDIN(SELF,
'INTEGRATED_CNC_SCHEMA.PROPERTY_DEFINITION.DEFINITION') |
(NOT (SIZEOF(QUERY ( dtm_rep <* QUERY ( pdr <* USEDIN(pd,
'INTEGRATED_CNC_SCHEMA.' +
'PROPERTY_DEFINITION_REPRESENTATION.DEFINITION') |
(('INTEGRATED_CNC_SCHEMA.' +
'SHAPE_REPRESENTATION_WITH_PARAMETERS')
IN TYPEOF(pdr.used_representation)) ) |
(NOT (SIZEOF(QUERY ( it <* dtm_rep.used_representation.items |
((SIZEOF([
'INTEGRATED_CNC_SCHEMA.MEASURE_REPRESENTATION_ITEM',
'INTEGRATED_CNC_SCHEMA.LENGTH_MEASURE_WITH_UNIT'] *
TYPEOF(it)) = 2) AND (it.name = 'target diameter')) )
= 1)) )) = 0)) )) = 0));
WR8 : ((NOT (SELF.description = 'line')) OR
(SIZEOF(QUERY ( pd <* USEDIN(SELF,
'INTEGRATED_CNC_SCHEMA.PROPERTY_DEFINITION.DEFINITION') |
(NOT (SIZEOF(QUERY ( dtm_rep <* QUERY ( pdr <* USEDIN(pd,
'INTEGRATED_CNC_SCHEMA.' +
'PROPERTY_DEFINITION_REPRESENTATION.DEFINITION') |
(('INTEGRATED_CNC_SCHEMA.' +
'SHAPE_REPRESENTATION_WITH_PARAMETERS')
IN TYPEOF(pdr.used_representation)) ) |
(NOT (SIZEOF(QUERY ( it <* dtm_rep.used_representation.items |
((SIZEOF([
'INTEGRATED_CNC_SCHEMA.MEASURE_REPRESENTATION_ITEM',
'INTEGRATED_CNC_SCHEMA.LENGTH_MEASURE_WITH_UNIT'] *
TYPEOF(it)) = 2) AND (it.name = 'target length')))) = 1)) ))
= 0)) )) = 0));
WR9 : ((NOT (SELF.description = 'rectangle')) OR
(SIZEOF(QUERY ( pd <* USEDIN(SELF,
'INTEGRATED_CNC_SCHEMA.PROPERTY_DEFINITION.DEFINITION') |
(NOT (SIZEOF(QUERY ( dtm_rep <* QUERY ( pdr <* USEDIN(pd,
'INTEGRATED_CNC_SCHEMA.' +
'PROPERTY_DEFINITION_REPRESENTATION.DEFINITION') |
(('INTEGRATED_CNC_SCHEMA.' +
'SHAPE_REPRESENTATION_WITH_PARAMETERS')
IN TYPEOF(pdr.used_representation)) ) |
(NOT (SIZEOF(QUERY ( it <* dtm_rep.used_representation.items |
((SIZEOF([
'INTEGRATED_CNC_SCHEMA.MEASURE_REPRESENTATION_ITEM',
'INTEGRATED_CNC_SCHEMA.LENGTH_MEASURE_WITH_UNIT'] *
TYPEOF(it)) = 2) AND (it.name = 'target length')))) = 1)) ))
= 0)) )) = 0));
WR10: ((NOT (SELF.description = 'rectangle')) OR
(SIZEOF(QUERY ( pd <* USEDIN(SELF,

```

```

        'INTEGRATED_CNC_SCHEMA.PROPERTY_DEFINITION.DEFINITION') |
        (NOT (SIZEOF(QUERY ( dtm_rep <* QUERY ( pdr <* USEDIN(pd,
        'INTEGRATED_CNC_SCHEMA.' +
        'PROPERTY_DEFINITION_REPRESENTATION.DEFINITION') |
        (('INTEGRATED_CNC_SCHEMA.' +
        'SHAPE_REPRESENTATION_WITH_PARAMETERS')
        IN TYPEOF(pdr.used_representation)) ) |
        (NOT (SIZEOF(QUERY ( it <* dtm_rep.used_representation.items |
        ((SIZEOF([
        'INTEGRATED_CNC_SCHEMA.MEASURE_REPRESENTATION_ITEM',
        'INTEGRATED_CNC_SCHEMA.LENGTH_MEASURE_WITH_UNIT'] *
        TYPEOF(it)) = 2) AND (it.name = 'target width'))))= 1)))
        = 0)) ))=0));
END_ENTITY; -- placed_datum_target_feature
(*

```

### Formal propositions:

**WR1:** The **description** for the **placed\_datum\_target\_feature** shall be either 'point', 'line', 'rectangle' or 'circle'.

**WR2:** A **placed\_datum\_target\_feature** shall have exactly one implicit representation.

**WR3:** Exactly one **representation\_item** used for the representation of the **placed\_datum\_target\_feature** shall be of type **placement** with a name of 'orientation'.

**WR4:** If the **placed\_datum\_target\_feature** is a point, the representation shall contain exactly one **representation\_item** in its set of items.

**WR5:** If the **placed\_datum\_target\_feature** is a line or circle, the representation shall contain exactly two **representation\_items** in its set of items.

**WR6:** If the **placed\_datum\_target\_feature** is a rectangle, the representation shall contain exactly three **representation\_items** in its set of items.

**WR7:** If the **description** of the **placed\_datum\_target\_feature** is 'circle', exactly one **representation\_item** used for the implicit representation of the **placed\_datum\_target\_feature** shall be of type **measure\_representation\_item** and **length\_measure\_with\_unit** with a name of 'target diameter'.

**WR8:** If the **description** of the **placed\_datum\_target\_feature** is 'line', exactly one **representation\_item** used for the implicit representation of the **placed\_datum\_target\_feature** shall be of type **measure\_representation\_item** and **length\_measure\_with\_unit** with a name of 'target length'.

**WR9:** If the **description** of the **placed\_datum\_target\_feature** is 'rectangle', exactly one **representation\_item** used for the implicit representation of the **placed\_datum\_target\_feature** shall be of type **measure\_representation\_item** and **length\_measure\_with\_unit** with a name of 'target length'.



**WR10:** If the **description** of the **placed\_datum\_target\_feature** is 'rectangle', exactly one **representation\_item** used for the implicit representation of the **placed\_datum\_target\_feature** shall be of type **measure\_representation\_item** and **length\_measure\_with\_unit** with a **name** of 'target width'.

### 5.2.3.1.86 plane\_milling\_operation

A **plane\_milling\_operation** is a type of **milling\_type\_operation** that represents a 2.5D milling step in which material is removed perpendicular to the cutting tool axis. See the ARM definitions for **Plane\_milling\_operation** and subtypes in ISO 14649-11 for more information.

#### EXPRESS specification:

```

*)
ENTITY plane_milling_operation
  SUBTYPE OF (milling_type_operation);
  WHERE
  WR1: (SELF.description IN ['roughing','finishing']);

  WR2: (verify_optional_action_property (SELF, 'axial cutting depth')) AND
        (verify_length_measure_action_property (SELF, 'axial cutting depth'));

  WR3: (verify_optional_action_property (SELF, 'allowance bottom')) AND
        (verify_length_measure_action_property (SELF, 'allowance bottom'));

  WR4: NOT (SELF.description = 'roughing') OR
        (verify_required_action_property (SELF, 'allowance bottom'));
END_ENTITY;
(*

```

#### Formal propositions:

**WR1:** The **description** of the **plane\_milling\_operation** shall be either 'roughing' or 'finishing'.

**WR2:** The **plane\_milling\_operation** shall be the **definition** of at most one **action\_property** with a **name** of 'axial cutting depth', and the **representation** used to describe the **action\_property** shall contain a **representation\_item** of type **measure\_representation\_item** and **length\_measure\_with\_unit**.

**WR3:** The **plane\_milling\_operation** shall be the **definition** of at most one **action\_property** with a **name** of 'allowance bottom', and the **representation** used to describe the **action\_property** shall contain a **representation\_item** of type **measure\_representation\_item** and **length\_measure\_with\_unit**.

**WR4:** If the **description** of the **plane\_milling\_operation** is 'roughing', the **plane\_milling\_operation** shall be the **definition** of exactly one **action\_property** with a **name** of 'allowance bottom'.

**NOTE** This corresponds to local constraint **WR1** on the ARM entity **Plane\_rough\_milling** in ISO 14649-11.

### 5.2.3.1.87 side\_milling\_operation

A **side\_milling\_operation** is a **milling\_type\_operation** that represents a 2.5D milling step in which material is removed parallel to the cutting tool axis. See the ARM definitions for **Side\_milling\_operation** and subtypes in ISO 14649-11 for more information.

#### EXPRESS specification:

```

*)
ENTITY side_milling_operation
  SUBTYPE OF (milling_type_operation);
  WHERE
  WR1: (SELF.description IN ['roughing','finishing']);

  WR2: (verify_optional_action_property (SELF, 'axial cutting depth')) AND
        (verify_length_measure_action_property (SELF, 'axial cutting depth'));

  WR3: (verify_optional_action_property (SELF, 'radial cutting depth')) AND
        (verify_length_measure_action_property (SELF, 'radial cutting depth'));

  WR4: (verify_optional_action_property (SELF, 'allowance side')) AND
        (verify_length_measure_action_property (SELF, 'allowance side'));

  WR5: NOT (SELF.description = 'roughing') OR
        (verify_required_action_property (SELF, 'allowance side'));
END_ENTITY;
(*

```

#### Formal propositions:

**WR1:** The **description** of the **side\_milling\_operation** shall be either 'roughing' or 'finishing'.

**WR2:** The **side\_milling\_operation** shall be the **definition** of at most one **action\_property** with a **name** of 'axial cutting depth', and the **representation** used to describe the **action\_property** shall contain a **representation\_item** of type **measure\_representation\_item** and **length\_measure\_with\_unit**.

**WR3:** The **side\_milling\_operation** shall be the **definition** of at most one **action\_property** with a **name** of 'radial cutting depth', and the **representation** used to describe the **action\_property** shall contain a **representation\_item** of type **measure\_representation\_item** and **length\_measure\_with\_unit**.

**WR4:** The **side\_milling\_operation** shall be the **definition** of at most one **action\_property** with a **name** of 'allowance side', and the **representation** used to describe the **action\_property** shall contain a **representation\_item** of type **measure\_representation\_item** and **length\_measure\_with\_unit**.

**WR5:** If the **description** of the **side\_milling\_operation** is 'roughing', the **side\_milling\_operation** shall be the **definition** of exactly one **action\_property** with a **name** of 'allowance side'.

NOTE This corresponds to local constraint **WR1** on the ARM entity **Side\_rough\_milling** in ISO 14649-11.

### 5.2.3.1.88 surface\_texture\_representation

A **surface\_texture\_representation** is a type of **representation** that represents a surface texture such as roughness or waviness. The kind of surface texture that is represented is given in the names of the **representation\_items**. The method or standard according to which the surface texture is represented is specified in the description of the **descriptive\_representation\_item**.

NOTE This definition has been harmonized with the equivalent definition in ISO 10303-214.

#### EXPRESS specification:

```
*)
ENTITY surface_texture_representation
  SUBTYPE OF (representation);
END_ENTITY;
(*
```

### 5.2.3.1.89 tapping\_operation

A **tapping\_operation** is a type of **drilling\_type\_operation** that represents the details of a drilling step in which in internal threads are cut. See the ARM definitions for Tapping and Thread\_drilling in ISO 14649-11 for more information.

#### EXPRESS specification:

```
*)
ENTITY tapping_operation
  SUBTYPE OF (drilling_type_operation);
  WHERE
    WR1: (SELF.description IN ['tapping','thread drilling']);

    WR2: NOT (SELF.description = 'tapping') OR
      ((verify_optional_action_property (SELF, 'compensation chuck') AND
        (verify_enumeration_action_property (SELF, 'compensation chuck',
          ['compensation chuck used', 'compensation chuck not used'])));

    WR3: NOT (SELF.description = 'thread drilling') OR
      ((verify_optional_action_property
        (SELF, 'helical movement on forward')) AND
        (verify_enumeration_action_property
          (SELF, 'helical movement on forward',
            ['helical movement on forward',
              'no helical movement on forward'])));
END_ENTITY;
(*
```

#### Formal propositions:

**WR1:** The **description** of the **tapping\_operation** shall be either 'tapping' or 'thread drilling'.

**WR2:** If the **description** of the **tapping\_operation** is 'tapping', the **tapping\_operation** shall be the **definition** of at most one **action\_property** with a **name** of 'compensation chuck', and the **representation** used to describe the **action\_property** shall contain a **representation\_item** of type **descriptive\_representation\_item** with a **description** of either 'compensation chuck used' or 'compensation chuck not used'.

**WR2:** If the **description** of the **tapping\_operation** is 'thread drilling', the **tapping\_operation** shall be the **definition** of at most one **action\_property** with a **name** of 'helical movement on forward', and the **representation** used to describe the **action\_property** shall contain a **representation\_item** of type **descriptive\_representation\_item** with a **description** of either 'helical movement on forward' or 'no helical movement on forward'.

### 5.2.3.1.90 threading\_turning\_operation

A **threading\_turning\_operation** is a **turning\_type\_operation**. See the ARM definitions for Threading and subtypes in ISO 14649-12 for more information.

#### EXPRESS specification:

```

*)
ENTITY threading_turning_operation
  SUBTYPE OF (turning_type_operation);
  WHERE
  WR1: (SELF.description IN ['roughing', 'finishing']);

  WR2: (verify_optional_action_property (SELF, 'allowance')) AND
        (verify_length_measure_action_property (SELF, 'allowance'));

  WR3: NOT (SELF.description = 'roughing') OR
        (verify_required_action_property (SELF, 'allowance'));
END_ENTITY;
(*

```

#### Formal propositions:

**WR1:** The **description** of the **threading\_turning\_operation** shall be either 'roughing' or 'finishing'.

**WR2:** The **threading\_turning\_operation** shall be the **definition** of at most one **action\_property** with a **name** of 'allowance', and the **representation** used to describe the **action\_property** shall contain a **representation\_item** of type **measure\_representation\_item** and **length\_measure\_with\_unit**.

**WR3:** If the **description** of the **threading\_turning\_operation** is 'roughing', the **threading\_turning\_operation** shall be the **definition** of exactly one **action\_property** with a **name** of 'allowance'.

**NOTE** This corresponds to local constraints **WR1** on the ARM entity **Threading\_rough** in ISO 14649-12.

### 5.2.3.1.91 turning\_type\_operation

A **turning\_type\_operation** is a type of **machining\_operation** that represents the details of a turning step of a machining process. See the ARM definitions for **Turning\_machining\_operation** and subtypes in ISO 14649-12 for more information.

#### EXPRESS specification:

```

*)
ENTITY turning_type_operation
  SUBTYPE OF (machining_operation);
  WHERE
  WR1: ((verify_optional_relatng_amr_with_name (SELF, 'approach',
    ['INTEGRATED_CNC_SCHEMA.MACHINING_STRATEGY_RELATIONSHIP'])) AND
    (verify_related_type_for_amr_with_name (SELF, 'approach',
    ['INTEGRATED_CNC_SCHEMA.MACHINING_STRATEGY_RELATIONSHIP'],
    ['INTEGRATED_CNC_SCHEMA.MACHINING_APPROACH_RETRACT_STRATEGY'])))
  );

  WR2: ((verify_optional_relatng_amr_with_name (SELF, 'retract',
    ['INTEGRATED_CNC_SCHEMA.MACHINING_STRATEGY_RELATIONSHIP'])) AND
    (verify_related_type_for_amr_with_name (SELF, 'retract',
    ['INTEGRATED_CNC_SCHEMA.MACHINING_STRATEGY_RELATIONSHIP'],
    ['INTEGRATED_CNC_SCHEMA.MACHINING_APPROACH_RETRACT_STRATEGY'])))
  );

  WR3: ((verify_optional_relatng_amr_with_name (SELF, 'machining',
    ['INTEGRATED_CNC_SCHEMA.MACHINING_STRATEGY_RELATIONSHIP'])) AND
    (verify_related_type_for_amr_with_name (SELF, 'machining',
    ['INTEGRATED_CNC_SCHEMA.MACHINING_STRATEGY_RELATIONSHIP'],
    ['INTEGRATED_CNC_SCHEMA.TURNING_TYPE_STRATEGY'])))
  );

END_ENTITY;
(*

```

#### Formal propositions:

**WR1:** The **turning\_type\_operation** shall be the **relating\_method** of at most one **machining\_strategy\_relationship** with a **name** of 'approach', and a **related\_method** of type **machining\_approach\_retract\_strategy**.

**WR2:** The **turning\_type\_operation** shall be the **relating\_method** of at most one **machining\_strategy\_relationship** with a **name** of 'retract', and a **related\_method** of type **machining\_approach\_retract\_strategy**.

**WR3:** The **turning\_type\_operation** shall be the **relating\_method** of at most one **machining\_strategy\_relationship** with a **name** of 'machining', and a **related\_method** of type **turning\_type\_strategy**.

### 5.2.3.1.92 turning\_type\_strategy

A **turning\_type\_strategy** is a type of **machining\_strategy** that represents the approach used to determine the motion of the cutting tool during a turning operation. See the ARM definitions for **Turning\_machining\_strategy** and subtypes in ISO 14649-12 for more information.

#### EXPRESS specification:

```

*)
ENTITY turning_type_strategy
  SUBTYPE OF (machining_strategy);
  WHERE
  WR1: (SELF.description IN ['unidirectional', 'bidirectional',
    'contour', 'thread', 'grooving', 'multistep grooving',
    'explicit']);

  WR2: ((verify_optional_action_property (SELF, 'overcut length')) AND
    (verify_length_measure_action_property (SELF, 'overcut length'))
    );

  WR3: ((verify_optional_action_property (SELF, 'multiple passes')) AND
    (verify_enumeration_action_property (SELF, 'multiple passes',
    ['multiple passes allowed', 'multiple passes not allowed']))
    );

  WR4: ((verify_optional_action_property (SELF, 'cutting depth')) AND
    (0 = SIZEOF (QUERY (prop <*
    get_action_property (SELF, 'cutting depth') | NOT
    (0 < SIZEOF (QUERY (prep <* USEDIN (prop, 'INTEGRATED_CNC_SCHEMA.' +
    'ACTION_PROPERTY_REPRESENTATION.PROPERTY') |
    (1 = SIZEOF (QUERY (it <* prep.representation.items |
    (('INTEGRATED_CNC_SCHEMA.COMPOUND_REPRESENTATION_ITEM'
    IN TYPEOF(it)) AND
    ('INTEGRATED_CNC_SCHEMA.LIST_REPRESENTATION_ITEM'
    IN TYPEOF(it.item_element)) AND
    (0 = SIZEOF (QUERY (ie <* it.item_element | NOT (SIZEOF([
    'INTEGRATED_CNC_SCHEMA.MEASURE_REPRESENTATION_ITEM',
    'INTEGRATED_CNC_SCHEMA.LENGTH_MEASURE_WITH_UNIT'] *
    TYPEOF(ie)) = 2))))
    ))))
    )))
    )))
    )))
    );

  WR5: ((verify_optional_action_property (SELF, 'variable feedrate')) AND
    (verify_rep_type_for_action_property (SELF, 'variable feedrate',
    ['INTEGRATED_CNC_SCHEMA.MACHINING_FEED_SPEED_REPRESENTATION'])) AND
    (verify_rep_name_for_action_property (SELF, 'variable feedrate',
    ['relative speed']))
    );

  WR6: NOT (SELF.description = 'unidirectional') OR
    ((verify_optional_action_property (SELF, 'feed direction')) AND

```

```

(verify_rep_item_for_action_property (SELF, 'feed direction',
  ['INTEGRATED_CNC_SCHEMA.DIRECTION'])) AND

(verify_optional_action_property (SELF, 'back path direction')) AND
(verify_rep_item_for_action_property (SELF, 'back path direction',
  ['INTEGRATED_CNC_SCHEMA.DIRECTION'])) AND

(verify_optional_action_property (SELF, 'lift direction')) AND
(verify_rep_item_for_action_property (SELF, 'lift direction',
  ['INTEGRATED_CNC_SCHEMA.DIRECTION'])) AND

(verify_optional_action_property (SELF, 'stepover direction')) AND
(verify_rep_item_for_action_property (SELF, 'stepover direction',
  ['INTEGRATED_CNC_SCHEMA.DIRECTION'])) AND

(verify_optional_action_property (SELF, 'lift height')) AND
(verify_length_measure_action_property (SELF, 'lift height')) AND

(verify_optional_action_property (SELF, 'lift feedrate')) AND
(verify_rep_type_for_action_property (SELF, 'lift feedrate',
  ['INTEGRATED_CNC_SCHEMA.MACHINING_FEED_SPEED_REPRESENTATION'])) AND
(verify_rep_name_for_action_property (SELF, 'lift feedrate',
  ['feed speed', 'feed per revolution'])) AND

(verify_optional_action_property (SELF, 'stepover feedrate')) AND
(verify_rep_type_for_action_property (SELF, 'stepover feedrate',
  ['INTEGRATED_CNC_SCHEMA.MACHINING_FEED_SPEED_REPRESENTATION'])) AND
(verify_rep_name_for_action_property (SELF, 'stepover feedrate',
  ['feed speed', 'feed per revolution']))
);

WR7: NOT (SELF.description = 'bidirectional') OR
((verify_optional_action_property (SELF, 'feed direction')) AND
(verify_rep_item_for_action_property (SELF, 'feed direction',
  ['INTEGRATED_CNC_SCHEMA.DIRECTION'])) AND

(verify_optional_action_property (SELF, 'stepover direction')) AND
(verify_rep_item_for_action_property (SELF, 'stepover direction',
  ['INTEGRATED_CNC_SCHEMA.DIRECTION'])) AND

(verify_optional_action_property (SELF, 'stepover feedrate')) AND
(verify_rep_type_for_action_property (SELF, 'stepover feedrate',
  ['INTEGRATED_CNC_SCHEMA.MACHINING_FEED_SPEED_REPRESENTATION'])) AND
(verify_rep_name_for_action_property (SELF, 'stepover feedrate',
  ['feed speed', 'feed per revolution']))
);

WR8: NOT (SELF.description = 'contour') OR
((verify_optional_action_property (SELF, 'feed direction')) AND
(verify_rep_item_for_action_property (SELF, 'feed direction',
  ['INTEGRATED_CNC_SCHEMA.DIRECTION'])) AND

(verify_optional_action_property (SELF, 'back path direction')) AND
(verify_rep_item_for_action_property (SELF, 'back path direction',

```

```

(['INTEGRATED_CNC_SCHEMA.DIRECTION'])) AND

(verify_optional_action_property      (SELF, 'lift direction')) AND
(verify_rep_item_for_action_property  (SELF, 'lift direction',
  ['INTEGRATED_CNC_SCHEMA.DIRECTION'])) AND

(verify_optional_action_property      (SELF, 'stepover direction')) AND
(verify_rep_item_for_action_property  (SELF, 'stepover direction',
  ['INTEGRATED_CNC_SCHEMA.DIRECTION'])) AND

(verify_optional_action_property      (SELF, 'lift height')) AND
(verify_length_measure_action_property (SELF, 'lift height')) AND

(verify_optional_action_property      (SELF, 'lift feedrate')) AND
(verify_rep_type_for_action_property  (SELF, 'lift feedrate',
  ['INTEGRATED_CNC_SCHEMA.MACHINING_FEED_SPEED_REPRESENTATION'])) AND
(verify_rep_name_for_action_property  (SELF, 'lift feedrate',
  ['feed speed', 'feed per revolution'])) AND

(verify_optional_action_property      (SELF, 'stepover feedrate')) AND
(verify_rep_type_for_action_property  (SELF, 'stepover feedrate',
  ['INTEGRATED_CNC_SCHEMA.MACHINING_FEED_SPEED_REPRESENTATION'])) AND
(verify_rep_name_for_action_property  (SELF, 'stepover feedrate',
  ['feed speed', 'feed per revolution'])) AND

(verify_optional_action_property      (SELF, 'variable stepover feedrate')) AND
(verify_rep_type_for_action_property  (SELF, 'variable stepover feedrate',
  ['INTEGRATED_CNC_SCHEMA.MACHINING_FEED_SPEED_REPRESENTATION'])) AND
(verify_rep_name_for_action_property  (SELF, 'variable stepover feedrate', ['relative speed']))
);

```

```

WR9: NOT (SELF.description = 'thread') OR
((verify_required_action_property      (SELF, 'cut in amount')) AND
(verify_enumeration_action_property  (SELF, 'cut in amount',
  ['constant depth', 'variable depth', 'constant removal amount'])) AND

(verify_required_action_property      (SELF, 'threading direction')) AND
(verify_enumeration_action_property  (SELF, 'threading direction',
  ['left', 'right', 'center', 'left zigzag', 'right zigzag'])) AND

(verify_optional_action_property      (SELF, 'path return angle')) AND
(verify_angle_measure_action_property (SELF, 'path return angle')) AND

(verify_optional_action_property      (SELF, 'lift height')) AND
(verify_length_measure_action_property (SELF, 'lift height'))
);

```

```

WR10: NOT (SELF.description IN ['grooving', 'multistep grooving']) OR
((verify_optional_action_property      (SELF, 'grooving direction')) AND
(verify_rep_item_for_action_property  (SELF, 'grooving direction',
  ['INTEGRATED_CNC_SCHEMA.DIRECTION'])) AND

```



```

        (verify_optional_action_property      (SELF, 'travel distance')) AND
        (verify_length_measure_action_property (SELF, 'travel distance'))
    );

    WR11: NOT (SELF.description = 'multistep grooving') OR
        ((verify_optional_action_property      (SELF, 'retract distance')) AND
         (verify_length_measure_action_property (SELF, 'retract distance'))
        );
END_ENTITY;
(*

```

### Formal propositions:

**WR1:** The **description** of the **turning\_type\_strategy** shall be either 'unidirectional', 'bidirectional', 'contour', 'thread', 'grooving', 'multistep grooving', or 'explicit'.

**WR2:** The **turning\_type\_strategy** shall be the **definition** of at most one **action\_property** with a **name** of 'overcut length', and the **representation** used to describe the **action\_property** shall contain a **representation\_item** of type **measure\_representation\_item** and **length\_measure\_with\_unit**.

**WR3:** The **turning\_type\_strategy** shall be the **definition** of at most one **action\_property** with a **name** of 'multiple passes', and the **representation** used to describe the **action\_property** shall contain a **representation\_item** of type **descriptive\_representation\_item** with a **description** of 'multiple passes allowed' or 'multiple passes not allowed'.

**WR4:** The **turning\_type\_strategy** shall be the **definition** of at most one **action\_property** with a **name** of 'cutting depth', and the **representation** used to describe the **action\_property** shall contain exactly one **compound\_representation\_item**, in which the **item\_element** is of type **list\_representation\_item** and contains only instances of type **measure\_representation\_item** and **length\_measure\_with\_unit**.

**WR5:** The **turning\_type\_strategy** shall be the **definition** of at most one **action\_property** with a **name** of 'variable feedrate', and the **representation** used to describe the **action\_property** shall be of type **machining\_feed\_speed\_representation** with a **description** of 'relative speed'.

**WR6:** If the **description** of the **turning\_type\_strategy** is 'unidirectional', the **turning\_type\_strategy** shall satisfy the following conditions:

- the **turning\_type\_strategy** shall be the **definition** of at most one **action\_property** with a **name** of 'feed direction', and the **representation** used to describe the **action\_property** shall contain a **representation\_item** of type **direction**;
- the **turning\_type\_strategy** shall be the **definition** of at most one **action\_property** with a **name** of 'back path direction', and the **representation** used to describe the **action\_property** shall contain a **representation\_item** of type **direction**;
- the **turning\_type\_strategy** shall be the **definition** of at most one **action\_property** with a **name** of 'lift direction', and the **representation** used to describe the **action\_property** shall contain a **representation\_item** of type **direction**;

- the **turning\_type\_strategy** shall be the **definition** of at most one **action\_property** with a **name** of 'stepover direction', and the **representation** used to describe the **action\_property** shall contain a **representation\_item** of type **direction**;
- the **turning\_type\_strategy** shall be the **definition** of at most one **action\_property** with a **name** of 'lift height', and the **representation** used to describe the **action\_property** shall contain a **representation\_item** of type **measure\_representation\_item** and **length\_measure\_with\_unit**;
- the **turning\_type\_strategy** shall be the **definition** of at most one **action\_property** with a **name** of 'lift feedrate', and the **representation** used to describe the **action\_property** shall be of type **machining\_feed\_speed\_representation** with a **description** of either 'feed speed' or 'feed per revolution';
- the **turning\_type\_strategy** shall be the **definition** of at most one **action\_property** with a **name** of 'stepover feedrate', and the **representation** used to describe the **action\_property** shall be of type **machining\_feed\_speed\_representation** with a **description** of either 'feed speed' or 'feed per revolution'.

**WR7:** If the **description** of the **turning\_type\_strategy** is 'bidirectional', the **turning\_type\_strategy** shall satisfy the following conditions:

- the **turning\_type\_strategy** shall be the **definition** of at most one **action\_property** with a **name** of 'feed direction', and the **representation** used to describe the **action\_property** shall contain a **representation\_item** of type **direction**;
- the **turning\_type\_strategy** shall be the **definition** of at most one **action\_property** with a **name** of 'stepover direction', and the **representation** used to describe the **action\_property** shall contain a **representation\_item** of type **direction**;
- the **turning\_type\_strategy** shall be the **definition** of at most one **action\_property** with a **name** of 'stepover feedrate', and the **representation** used to describe the **action\_property** shall be of type **machining\_feed\_speed\_representation** with a **description** of either 'feed speed' or 'feed per revolution'.

**WR8:** If the **description** of the **turning\_type\_strategy** is 'contour', the **turning\_type\_strategy** shall satisfy the following conditions:

- the **turning\_type\_strategy** shall be the **definition** of at most one **action\_property** with a **name** of 'feed direction', and the **representation** used to describe the **action\_property** shall contain a **representation\_item** of type **direction**;
- the **turning\_type\_strategy** shall be the **definition** of at most one **action\_property** with a **name** of 'back path direction', and the **representation** used to describe the **action\_property** shall contain a **representation\_item** of type **direction**;
- the **turning\_type\_strategy** shall be the **definition** of at most one **action\_property** with a **name** of 'lift direction', and the **representation** used to describe the **action\_property** shall contain a **representation\_item** of type **direction**;

- the **turning\_type\_strategy** shall be the **definition** of at most one **action\_property** with a **name** of 'stepover direction', and the **representation** used to describe the **action\_property** shall contain a **representation\_item** of type **direction**;
- the **turning\_type\_strategy** shall be the **definition** of at most one **action\_property** with a **name** of 'lift height', and the **representation** used to describe the **action\_property** shall contain a **representation\_item** of type **measure\_representation\_item** and **length\_measure\_with\_unit**;
- the **turning\_type\_strategy** shall be the **definition** of at most one **action\_property** with a **name** of 'lift feedrate', and the **representation** used to describe the **action\_property** shall be of type **machining\_feed\_speed\_representation** with a **description** of either 'feed speed' or 'feed per revolution';
- the **turning\_type\_strategy** shall be the **definition** of at most one **action\_property** with a **name** of 'stepover feedrate', and the **representation** used to describe the **action\_property** shall be of type **machining\_feed\_speed\_representation** with a **description** of either 'feed speed' or 'feed per revolution';
- the **turning\_type\_strategy** shall be the **definition** of at most one **action\_property** with a **name** of 'variable stepover feedrate', and the **representation** used to describe the **action\_property** shall be of type **machining\_feed\_speed\_representation** with a **description** of 'relative speed'.

**WR9:** If the **description** of the **turning\_type\_strategy** is 'thread', the **turning\_type\_strategy** shall satisfy the following conditions:

- the **turning\_type\_strategy** shall be the **definition** of at most one **action\_property** with a **name** of 'cut in amount', and the **representation** used to describe the **action\_property** shall contain a **representation\_item** of type **descriptive\_representation\_item** with a **description** of 'constant depth', 'variable depth', or 'constant removal amount';
- the **turning\_type\_strategy** shall be the **definition** of at most one **action\_property** with a **name** of 'threading direction', and the **representation** used to describe the **action\_property** shall contain a **representation\_item** of type **descriptive\_representation\_item** with a **description** of 'left', 'right', 'center', 'left zigzag', or 'right zigzag';
- the **turning\_type\_strategy** shall be the **definition** of at most one **action\_property** with a **name** of 'path return angle', and the **representation** used to describe the **action\_property** shall contain a **representation\_item** of type **measure\_representation\_item** and **plane\_angle\_measure\_with\_unit**;
- the **turning\_type\_strategy** shall be the **definition** of at most one **action\_property** with a **name** of 'lift height', and the **representation** used to describe the **action\_property** shall contain a **representation\_item** of type **measure\_representation\_item** and **length\_measure\_with\_unit**.

**WR10:** If the **description** of the **turning\_type\_strategy** is either 'grooving' or 'multistep grooving', the **turning\_type\_strategy** shall satisfy the following conditions:

- the **turning\_type\_strategy** shall be the **definition** of at most one **action\_property** with a **name** of 'grooving direction', and the **representation** used to describe the **action\_property** shall contain a **representation\_item** of type **direction**;
- the **turning\_type\_strategy** shall be the **definition** of at most one **action\_property** with a **name** of 'travel distance', and the **representation** used to describe the **action\_property** shall contain a **representation\_item** of type **measure\_representation\_item** and **length\_measure\_with\_unit**.

**WR11:** If the **description** of the **turning\_type\_strategy** is 'multistep grooving', the **turning\_type\_strategy** shall be the **definition** of at most one **action\_property** with a **name** of 'retract distance', and the **representation** used to describe the **action\_property** shall contain a **representation\_item** of type **measure\_representation\_item** and **length\_measure\_with\_unit**.

### 5.2.3.1.93 value\_range

A **value\_range** is a type of **compound\_representation\_item** that specifies a range of values defined by two **measure\_representation\_items**, one with a name of 'upper limit' and the other with a name of 'lower limit'.

**NOTE** This definition has been harmonized with the equivalent definitions found in ISO 10303-214 and ISO 10303-1106.

EXPRESS specification:

```
*)  
ENTITY value_range  
  SUBTYPE OF (compound_representation_item);  
END_ENTITY;  
(*
```

### 5.2.3.2 Integrated CNC imported entity modifications

#### 5.2.3.2.1 application\_context

The base definition of the **application\_context** entity is given in ISO 10303-41. The following modifications apply to this part of ISO 10303.

Associated global rules:

The following global rule defined in this part of ISO 10303 applies to the **application\_context** entity:

- application\_context\_requires\_ap\_definition (See 5.2.4.1).

#### 5.2.3.2.2 application\_protocol\_definition

The base definition of the **application\_protocol\_definition** entity is given in ISO 10303-41. The following modifications apply to this part of ISO 10303.

Associated global rules:

The following global rule defined in this part of ISO 10303 applies to the **application\_protocol\_definition** entity:

— application\_context\_requires\_ap\_definition (See 5.2.4.1).

**5.2.3.2.3 approval**

The base definition of the **approval** entity is given in ISO 10303-41. The following modifications apply to this part of ISO 10303.

Associated global rules:

The following global rule defined in this part of ISO 10303 applies to the **approval** entity:

— approval\_requires\_approval\_person\_organization (See 5.2.4.2);

— approval\_requires\_assignment (See 5.2.4.3).

**5.2.3.2.4 approval\_assignment**

The base definition of the **approval\_assignment** entity is given in ISO 10303-41. The following modifications apply to this part of ISO 10303.

Associated global rules:

The following global rule defined in this part of ISO 10303 applies to the **approval\_assignment** entity:

— approval\_requires\_assignment (See 5.2.4.3).

**5.2.3.2.5 approval\_person\_organization**

The base definition of the **approval\_person\_organization** entity is given in ISO 10303-41. The following modifications apply to this part of ISO 10303.

Associated global rules:

The following global rule defined in this part of ISO 10303 applies to the **approval\_person\_organization** entity:

— approval\_requires\_approval\_person\_organization (See 5.2.4.2).

**5.2.3.2.6 approval\_status**

The base definition of the **approval\_status** entity is given in ISO 10303-41. The following modifications apply to this part of ISO 10303.

ISO 10303-238:2007(E)

Associated global rules:

The following global rule defined in this part of ISO 10303 applies to the **approval\_status** entity:

— dependent\_instantiable\_approval\_status (See 5.2.4.5).

### 5.2.3.2.7 chamfer

The base definition of the **chamfer** entity is given in ISO 10303-522. The following modifications apply to this part of ISO 10303.

Associated global rules:

The following global rule defined in this part of ISO 10303 applies to the **chamfer** entity:

— chamfer\_requires\_faces\_or\_features (See 5.2.4.4).

### 5.2.3.2.8 derived\_unit

The base definition of the **derived\_unit** entity is given in ISO 10303-41. The following modifications apply to this part of ISO 10303.

Associated global rules:

The following global rule defined in this part of ISO 10303 applies to the **derived\_unit** entity:

— dependent\_instantiable\_derived\_unit (See 5.2.4.6).

### 5.2.3.2.9 edge\_round

The base definition of the **edge\_round** entity is given in ISO 10303-522. The following modifications apply to this part of ISO 10303.

Associated global rules:

The following global rule defined in this part of ISO 10303 applies to the **edge\_round** entity:

— edge\_round\_requires\_faces\_or\_features (See 5.2.4.8).

### 5.2.3.2.10 named\_unit

The base definition of the **named\_unit** entity is given in ISO 10303-41. The following modifications apply to this part of ISO 10303.

Associated global rules:

The following global rule defined in this part of ISO 10303 applies to the **named\_unit** entity:

— `dependent_instantiable_named_unit` (See 5.2.4.7).

### 5.2.3.2.11 `numeric_variable`

The base definition of the **`numeric_variable`** entity is given in ISO 13584-20. The following modifications apply to this part of ISO 10303.

Associated global rules:

The following global rule defined in this part of ISO 10303 applies to the **`numeric_variable`** entity:

— `nc_variable_compatible_initial_value` (See 5.2.4.10).

### 5.2.3.2.12 `process_property_association`

The base definition of the **`process_property_association`** entity is given in ISO 10303-49. The following modifications apply to this part of ISO 10303.

Associated global rules:

The following global rule defined in this part of ISO 10303 applies to the **`process_property_association`** entity:

— `feature_optional_machining_property_process` (See 5.2.4.9).

### 5.2.3.2.13 `product`

The base definition of the **`product`** entity is given in ISO 10303-41. The following modifications apply to this part of ISO 10303.

Associated global rules:

The following global rule defined in this part of ISO 10303 applies to the **`product`** entity:

— `product_requires_version` (See 5.2.4.11).

### 5.2.3.2.14 `product_definition_formation`

The base definition of the **`product_definition_formation`** entity is given in ISO 10303-41. The following modifications apply to this part of ISO 10303.

Associated global rules:

The following global rule defined in this part of ISO 10303 applies to the **`product_definition_formation`** entity:

— `product_requires_version` (See 5.2.4.11).

### 5.2.3.2.15 **representation\_item\_relationship**

The base definition of the **representation\_item\_relationship** entity is given in ISO 10303-43. The following modifications apply to this part of ISO 10303.

#### Associated global rules:

The following global rule defined in this part of ISO 10303 applies to the **representation\_item\_relationship** entity:

— `nc_variable_compatible_initial_value` (See 5.2.4.10).

### 5.2.3.2.16 **security\_classification**

The base definition of the **security\_classification** entity is given in ISO 10303-41. The following modifications apply to this part of ISO 10303.

#### Associated global rules:

The following global rule defined in this part of ISO 10303 applies to the **security\_classification** entity:

— `security_classification_requires_assignment` (See 5.2.4.13).

### 5.2.3.2.17 **security\_classification\_assignment**

The base definition of the **security\_classification\_assignment** entity is given in ISO 10303-41. The following modifications apply to this part of ISO 10303.

#### Associated global rules:

The following global rule defined in this part of ISO 10303 applies to the **security\_classification\_assignment** entity:

— `security_classification_requires_assignment` (See 5.2.4.13).

### 5.2.3.2.18 **shape\_aspect**

The base definition of the **shape\_aspect** entity is given in ISO 10303-41. The following modifications apply to this part of ISO 10303.

#### Associated global rules:

The following global rule defined in this part of ISO 10303 applies to the **shape\_aspect** entity:

— `feature_optional_machining_property_process` (See 5.2.4.9).



## 5.2.4 Integrated CNC rule definitions

### 5.2.4.1 application\_context\_requires\_ap\_definition

The **application\_context\_requires\_ap\_definition** rule specifies that each instance of **application\_context** shall be referenced by exactly one **application\_protocol\_definition** that specifies this part of ISO 10303.

EXPRESS specification:

```
*)
RULE application_context_requires_ap_definition FOR
  (application_context, application_protocol_definition);
WHERE
  WR1: (0 = SIZEOF (QUERY (ac <* application_context | NOT
    (1 = SIZEOF (QUERY (apd <* application_protocol_definition |
      (apd.application :=: ac) AND
      (apd.application_interpreted_model_schema_name =
        'integrated_cnc_schema'))))
    ));
END_RULE;
(*
```

Argument definitions:

**application\_context:** the set of all instances of **application\_context**.

**application\_protocol\_definition:** the set of all instances of **application\_protocol\_definition**.

Formal propositions:

**WR1:** For each instance of **application\_context**, there shall be exactly one instance of **application\_protocol\_definition** that references the instance of **application\_context** as its **application** with a value of 'integrated\_cnc\_schema' as its **application\_interpreted\_model\_schema\_name**.

### 5.2.4.2 approval\_requires\_approval\_person\_organization

The **approval\_requires\_approval\_person\_organization** specifies that each instance of **approval** shall be referenced by at least one **approval\_person\_organization**.

EXPRESS specification:

```
*)
RULE approval_requires_approval_person_organization FOR
  (approval, approval_person_organization);
WHERE
  WR1: (0 = SIZEOF (QUERY (app <* approval | NOT
    (1 <= SIZEOF (QUERY (apo <* approval_person_organization |
      (app :=: apo.authorized_approval))))
    ));
```

ISO 10303-238:2007(E)

END\_RULE;  
(\*

Argument definitions:

**approval:** the set of all instances of **approval**.

**approval\_person\_organization:** the set of all instances of **approval\_person\_organization**.

Formal propositions:

**WR1:** For each instance of **approval**, there shall be at least one instance of **approval\_person\_organization** in which the **approval** appears as the **authorized\_approval**.

### 5.2.4.3 approval\_requires\_assignment

The **approval\_requires\_assignment** specifies that each instance of **approval** shall be referenced by at least one **approval\_assignment**.

EXPRESS specification:

```
*)  
RULE approval_requires_assignment FOR  
  (approval, approval_assignment);  
WHERE  
  WR1: (0 = SIZEOF (QUERY (app <* approval | NOT  
    (1 <= SIZEOF (QUERY (aa <* approval_assignment |  
      (app :=: aa.assigned_approval))))  
    )));  
END_RULE;  
(*
```

Argument definitions:

**approval:** the set of all instances of **approval**.

**approval\_assignment:** the set of all instances of **approval\_assignment**.

Formal propositions:

**WR1:** For each instance of **approval**, there shall be at least one instance of **approval\_assignment** in which the **approval** appears as the **assigned\_approval**.

### 5.2.4.4 chamfer\_requires\_faces\_or\_features

The **chamfer\_requires\_faces\_or\_features** rule specifies that each instance of **chamfer** shall define the transition between either two features or two sets of faces on the workpiece.

EXPRESS specification:

```

*)
RULE chamfer_requires_faces_or_features FOR (
    chamfer,
    property_definition_representation,
    feature_component_relationship
);

WHERE
WR1: (0 = SIZEOF (QUERY (cf <* chamfer | NOT (

-- chamfer relates two sets of faces in AP 224 style
((1 = SIZEOF (QUERY (pdr <* property_definition_representation |
    ((pdr.used_representation.name = 'chamfer face') AND
    (pdr.definition.definition ::= cf) AND
    ('INTEGRATED_CNC_SCHEMA.FACE_SHAPE_REPRESENTATION'
    IN TYPEOF (pdr.used_representation)))))) AND

(1 = SIZEOF (QUERY (fcr <* feature_component_relationship |
    ((fcr.relater_shape_aspect ::= cf) AND
    (fcr.related_shape_aspect.description = 'first offset') AND
    ('INTEGRATED_CNC_SCHEMA.CHAMFER_OFFSET'
    IN TYPEOF (fcr.related_shape_aspect)) AND
    ((1 = SIZEOF (QUERY (pdr <* property_definition_representation |
        ((pdr.used_representation.name = 'first face shape') AND
        (pdr.definition.definition ::= fcr.related_shape_aspect) AND
        ('INTEGRATED_CNC_SCHEMA.FACE_SHAPE_REPRESENTATION'
        IN TYPEOF (pdr.used_representation)))
    )))) )))) AND

(1 = SIZEOF (QUERY (fcr <* feature_component_relationship |
    ((fcr.relater_shape_aspect ::= cf) AND
    (fcr.related_shape_aspect.description = 'second offset') AND
    ('INTEGRATED_CNC_SCHEMA.CHAMFER_OFFSET'
    IN TYPEOF (fcr.related_shape_aspect)) AND
    ((1 = SIZEOF (QUERY (pdr <* property_definition_representation |
        ((pdr.used_representation.name = 'second face shape') AND
        (pdr.definition.definition ::= fcr.related_shape_aspect) AND
        ('INTEGRATED_CNC_SCHEMA.FACE_SHAPE_REPRESENTATION'
        IN TYPEOF (pdr.used_representation)))
    )))) ))))

)
OR
-- chamfer relates two features in ISO 14649 style
((1 = SIZEOF (QUERY (fcr <* feature_component_relationship |
    ((fcr.name = 'first feature') AND
    (fcr.relater_shape_aspect.of_shape.definition ::= cf) AND
    ('INTEGRATED_CNC_SCHEMA.COMPOSITE_SHAPE_ASPECT'
    IN TYPEOF (fcr.relater_shape_aspect)))))) AND

(1 = SIZEOF (QUERY (fcr <* feature_component_relationship |
    ((fcr.name = 'second feature') AND

```

```

        (fcr.relating_shape_aspect.of_shape.definition ::= cf) AND
        ('INTEGRATED_CNC_SCHEMA.COMPOSITE_SHAPE_ASPECT'
         IN TYPEOF (fcr.relating_shape_aspect))))))
    )));
END_RULE;
(*

```

Argument definitions:

**chamfer:** the set of all instances of **chamfer**.

**property\_definition\_representation:** the set of all instances of **property\_definition\_representation**.

**feature\_component\_relationship:** the set of all instances of **feature\_component\_relationship**.

Formal propositions:

**WR1:** For each instance of **chamfer**, either:

- the **chamfer** shall be related to exactly one **property\_definition\_representation** with a **used\_representation** of type **face\_shape\_representation** with a **name** of 'chamfer face';
- the **chamfer** shall be the **relating\_shape\_aspect** of exactly one **feature\_component\_relationship** with a **description** of 'first offset' and a **related\_shape\_aspect** of type **chamfer\_offset**. The **chamfer\_offset** shall be related to exactly one **property\_definition\_representation** with a **used\_representation** of type **face\_shape\_representation** with a **name** of 'first face shape';
- the **chamfer** shall be the **relating\_shape\_aspect** of exactly one **feature\_component\_relationship** with a **description** of 'second offset' and a **related\_shape\_aspect** of type **chamfer\_offset**. The **chamfer\_offset** shall be related to exactly one **property\_definition\_representation** with a **used\_representation** of type **face\_shape\_representation** with a **name** of 'second face shape'.

or else:

- the **chamfer** shall be the related by the **of\_shape** attribute of a **composite\_shape\_aspect** which is the **relating\_shape\_aspect** of exactly one **feature\_component\_relationship** with a **name** of 'first feature';
- the **chamfer** shall be the related by the **of\_shape** attribute of a **composite\_shape\_aspect** which is the **relating\_shape\_aspect** of exactly one **feature\_component\_relationship** with a **name** of 'second feature'.

### 5.2.4.5 dependent\_instantiable\_approval\_status

The **dependent\_instantiable\_approval\_status** rule specifies that each instance of **approval\_status** is dependent on its usage to define another entity.

EXPRESS specification:

\*)

```

RULE dependent_instantiable_approval_status FOR (approval_status);
WHERE
  WR1: (0 = SIZEOF (QUERY (ast <* approval_status | NOT
    (1 <= SIZEOF (USEDIN (ast, '')))
  )));
END_RULE;
(*)

```

Argument definitions:

**approval\_status:** the set of all instances of **approval\_status**.

Formal propositions:

**WR1:** For each instance of **approval\_status**, there shall be at least one reference to the **approval\_status** instance from an attribute of another entity.

### 5.2.4.6 dependent\_instantiable\_derived\_unit

The **dependent\_instantiable\_derived\_unit** rule specifies that each instance of **derived\_unit** is dependent on its usage to define another entity.

EXPRESS specification:

```

*)
RULE dependent_instantiable_derived_unit FOR (derived_unit);
WHERE
  WR1: (0 = SIZEOF (QUERY (du <* derived_unit | NOT
    (1 <= SIZEOF (USEDIN (du, '')))
  )));
END_RULE;
(*)

```

Argument definitions:

**derived\_unit:** the set of all instances of **derived\_unit**.

Formal propositions:

**WR1:** For each instance of **derived\_unit**, there shall be at least one reference to the **derived\_unit** instance from an attribute of another entity.

### 5.2.4.7 dependent\_instantiable\_named\_unit

The **dependent\_instantiable\_named\_unit** rule specifies that each instance of **named\_unit** is dependent on its usage to define another entity.

EXPRESS specification:

```

*)

```

```

RULE dependent_instantiable_named_unit FOR (named_unit);
WHERE
  WR1: (0 = SIZEOF (QUERY (nu <* named_unit | NOT
    (1 <= SIZEOF (USEDIN (nu, '')))
  )));
END_RULE;
(*

```

Argument definitions:

**named\_unit:** the set of all instances of **named\_unit**.

Formal propositions:

**WR1:** For each instance of **named\_unit**, there shall be at least one reference to the **named\_unit** instance from an attribute of another entity.

**5.2.4.8 edge\_round\_requires\_faces\_or\_features**

The **edge\_round\_requires\_faces\_or\_features** rule specifies that each instance of **edge\_round** shall define the transition between either two features or two sets of faces on the workpiece.

EXPRESS specification:

```

*)
RULE edge_round_requires_faces_or_features FOR (
  edge_round,
  property_definition_representation,
  feature_component_relationship
);

WHERE
WR1: (0 = SIZEOF (QUERY (er <* edge_round | NOT (
  -- edge round relates two sets of faces in AP 224 style
  ((1 = SIZEOF (QUERY (pdr <* property_definition_representation |
    ((pdr.used_representation.name = 'edge round face') AND
    (pdr.definition.definition ::= er) AND
    ('INTEGRATED_CNC_SCHEMA.FACE_SHAPE_REPRESENTATION'
    IN TYPEOF (pdr.used_representation)))))) AND

  (1 = SIZEOF (QUERY (pdr <* property_definition_representation |
    ((pdr.used_representation.name = 'first face shape') AND
    (pdr.definition.definition ::= er) AND
    ('INTEGRATED_CNC_SCHEMA.FACE_SHAPE_REPRESENTATION'
    IN TYPEOF (pdr.used_representation)))))) AND

  (1 = SIZEOF (QUERY (pdr <* property_definition_representation |
    ((pdr.used_representation.name = 'second face shape') AND
    (pdr.definition.definition ::= er) AND
    ('INTEGRATED_CNC_SCHEMA.FACE_SHAPE_REPRESENTATION'
    IN TYPEOF (pdr.used_representation))))))

```

```

)
OR
-- edge round relates two features in ISO 14649 style
((1 = SIZEOF (QUERY (fcr <* feature_component_relationship |
  ((fcr.name = 'first feature') AND
   (fcr.relating_shape_aspect.of_shape.definition ::= er) AND
   ('INTEGRATED_CNC_SCHEMA.COMPOSITE_SHAPE_ASPECT'
    IN TYPEOF (fcr.relating_shape_aspect)))))) AND

  (1 = SIZEOF (QUERY (fcr <* feature_component_relationship |
    ((fcr.name = 'second feature') AND
     (fcr.relating_shape_aspect.of_shape.definition ::= er) AND
     ('INTEGRATED_CNC_SCHEMA.COMPOSITE_SHAPE_ASPECT'
      IN TYPEOF (fcr.relating_shape_aspect))))))
  ))));
END_RULE;
(*

```

Argument definitions:

**edge\_round:** the set of all instances of **edge\_round**.

**property\_definition\_representation:** the set of all instances of **property\_definition\_representation**.

**feature\_component\_relationship:** the set of all instances of **feature\_component\_relationship**.

Formal propositions:

**WR1:** For each instance of **chamfer**, either:

- the **edge\_round** shall be related to exactly one **property\_definition\_representation** with a **used\_representation** of type **face\_shape\_representation** with a **name** of 'edge round face';
- the **edge\_round** shall be related to exactly one **property\_definition\_representation** with a **used\_representation** of type **face\_shape\_representation** with a **name** of 'first face shape';
- the **edge\_round** shall be related to exactly one **property\_definition\_representation** with a **used\_representation** of type **face\_shape\_representation** with a **name** of 'second face shape'.

or else:

- the **edge\_round** shall be related by the **of\_shape** attribute of a **composite\_shape\_aspect** which is the **relating\_shape\_aspect** of exactly one **feature\_component\_relationship** with a **name** of 'first feature';
- the **edge\_round** shall be related by the **of\_shape** attribute of a **composite\_shape\_aspect** which is the **relating\_shape\_aspect** of exactly one **feature\_component\_relationship** with a **name** of 'second feature'.

### 5.2.4.9 feature\_optional\_machining\_property\_process

The **feature\_optional\_machining\_process\_property** rule specifies that each **feature\_definition** or **transition\_feature** instance shall be associated with at most one **property\_process** having a **name** of 'machining'.

#### EXPRESS specification:

```

*)
RULE feature_optional_machining_property_process FOR (
    shape_aspect,
    process_property_association
);
WHERE
WR1: (0 = SIZEOF (QUERY (sa <* shape_aspect |
    ('INTEGRATED_CNC_SCHEMA.FEATURE_DEFINITION' IN TYPEOF (sa)) OR
    ('INTEGRATED_CNC_SCHEMA.TRANSITION_FEATURE' IN TYPEOF (sa)))
    AND NOT
    (1 >= SIZEOF (QUERY (ppa <* process_property_association |
        ((ppa.property_or_shape ==: sa) AND
        (ppa.process.name = 'machining')))))
    ));
END_RULE;
(*

```

#### Argument definitions:

**shape\_aspect:** the set of all instances of **shape\_aspect**.

**process\_property\_association:** the set of all instances of **process\_property\_association**.

#### Formal propositions:

**WR1:** Each **shape\_aspect** that is an instance of either **feature\_definition** or **transition\_feature** shall appear as the **property\_or\_shape** of at most one **process\_property\_association** in which the **process** attribute refers to a **property\_process** having a **name** of 'machining'.

### 5.2.4.10 nc\_variable\_compatible\_initial\_value

The **nc\_variable\_compatible\_initial\_value** rule specifies that each instance of **numeric\_variable** that is also an **expression\_representation\_item** shall be associated with at most one initial value, given by a **literal\_value**. Furthermore, the initial value shall be of type **int\_literal** if the **numeric\_variable** is of type **int\_numeric\_variable**, and of type **real\_literal** if the **numeric\_variable** is of type **real\_numeric\_variable**.

#### EXPRESS specification:

```

*)
RULE nc_variable_compatible_initial_value FOR
    (expression_representation_item,

```



```

    representation_item_relationship);
WHERE
-- each nc_variable has at most one one initial value
WR1: (0 = SIZEOF (QUERY (nv <* expression_representation_item |
    ('INTEGRATED_CNC_SCHEMA.NUMERIC_VARIABLE'
    IN TYPEOF (nv)) AND NOT
    (1 >= SIZEOF (QUERY (rir <* representation_item_relationship |
        (rir.description = 'initial value') AND
        (rir.relying_representation_item ::= nv)
    ))))));

-- the types on either side of the initial value relationship must match
-- each nc_variable has at most one one initial value
WR2: (0 = SIZEOF (QUERY (rir <* representation_item_relationship |
    (rir.description = 'initial value') AND
    ('INTEGRATED_CNC_SCHEMA.NUMERIC_VARIABLE'
    IN TYPEOF (rir.relying_representation_item))
    AND NOT
    (((('INTEGRATED_CNC_SCHEMA.INT_NUMERIC_VARIABLE'
    IN TYPEOF (rir.relying_representation_item)) AND
    ('INTEGRATED_CNC_SCHEMA.INT_LITERAL'
    IN TYPEOF (rir.related_representation_item)))
    OR
    (((('INTEGRATED_CNC_SCHEMA.REAL_NUMERIC_VARIABLE'
    IN TYPEOF (rir.relying_representation_item)) AND
    ('INTEGRATED_CNC_SCHEMA.REAL_LITERAL'
    IN TYPEOF (rir.related_representation_item)
    ))))));
END_RULE;
(*

```

#### Argument definitions:

**expression\_representation\_item:** the set of all instances of **expression\_representation\_item**.

**representation\_item\_relationship:** the set of all instances of **representation\_item\_relationship**.

#### Formal propositions:

**WR1:** Each instance of **expression\_representation\_item** that is also of type **numeric\_variable** shall appear as **relying** in at most one **representation\_item\_relationship** in which the **name** is 'initial value'.

**WR2:** Each instance **representation\_item\_relationship** in which **name** is 'initial value' and **relying** is of type **numeric\_variable** shall have either **relying** of type **int\_numeric\_variable** and **related** of type **int\_literal** or **relying** of type **real\_numeric\_variable** and **related** of type **real\_literal**.

### 5.2.4.11 product\_requires\_version

The **product\_requires\_version** rule specifies that each instance of **product** shall be referenced by at least one instance of **product\_definition\_formation**.

EXPRESS specification:

```
*)
RULE product_requires_version FOR (product, product_definition_formation);
WHERE
  WR1: (0 = SIZEOF (QUERY (prod <* product | NOT
    (1 <= SIZEOF (QUERY (pdf <* product_definition_formation |
      (prod :=: pdf.of_product))))
    )));
END_RULE;
(*
```

Argument definitions:

**product:** the set of all instances of **product**.

**product\_definition\_formation:** the set of all instances of **product\_definition\_formation**.

Formal propositions:

**WR1:** For each instance of **product**, there shall be at least one instance of **product\_definition\_formation** that contains an **of\_product** attribute value equal to the **product**.

### 5.2.4.12 restrict\_unneeded\_feature\_usage

The **restrict\_unneeded\_feature\_usage** rule specifies that no instance of **feature\_definition** shall be of type **fillet**, **marking**, **protrusion**, or **rib\_top**.

**NOTE** These extra features are present for compatibility with ISO 10303-224, but are restricted until ISO 14649-10 or some other part requires them.

EXPRESS specification:

```
*)
RULE restrict_unneeded_feature_usage FOR (feature_definition);
WHERE
  WR1: (0 = SIZEOF (QUERY (fd <* feature_definition |
    ('INTEGRATED_CNC_SCHEMA.FILLET' IN TYPEOF(fd)) OR
    ('INTEGRATED_CNC_SCHEMA.GEAR' IN TYPEOF(fd)) OR
    ('INTEGRATED_CNC_SCHEMA.MARKING' IN TYPEOF(fd)) OR
    ('INTEGRATED_CNC_SCHEMA.PROTRUSION' IN TYPEOF(fd)) OR
    ('INTEGRATED_CNC_SCHEMA.RIB_TOP' IN TYPEOF(fd))
    )));
END_RULE;
(*
```

Argument definitions:

**feature\_definition:** the set of all instances of **feature\_definition**.

Formal propositions:

**WR1:** Each instance of **feature\_definition** shall not be of type **fillet**, **gear**, **marking**, **protrusion**, or **rib\_top**.

### 5.2.4.13 security\_classification\_requires\_assignment

The **security\_classification\_requires\_assignment** specifies that each instance of **security\_classification** shall be referenced by at least one **security\_classification\_assignment**.

EXPRESS specification:

```

*)
RULE security_classification_requires_assignment FOR
  (security_classification, security_classification_assignment);
WHERE
  WR1: (0 = SIZEOF (QUERY (sc <* security_classification | NOT
    (1 <= SIZEOF (QUERY (sca <* security_classification_assignment |
      (sc ::= sca.assigned_security_classification))))
    ))) ;
END_RULE;
(*

```

Argument definitions:

**security\_classification:** the set of all instances of **security\_classification**.

**security\_classification\_assignment:** the set of all instances of **security\_classification\_assignment**.

Formal propositions:

**WR1:** For each instance of **security\_classification**, there shall be at least one instance of **security\_classification\_assignment** in which the **security\_classification** appears as the **assigned\_security\_classification**.

## 5.2.5 Integrated CNC function definitions

### 5.2.5.1 get\_action\_property

The **get\_action\_property** function returns the set of **action\_property** instances that refer to the input **characterized\_action\_definition** and have a **name** equal to the input parameter **prop\_name**.

EXPRESS specification:

```

*)
FUNCTION get_action_property (
  cad:          characterized_action_definition;
  prop_name:    STRING
): SET OF action_property;

```

```

RETURN (bag_to_set (QUERY (ap <*
    USEDIN (cad, 'INTEGRATED_CNC_SCHEMA.ACTION_PROPERTY.DEFINITION') |
    (ap.name = prop_name)))));
END_FUNCTION;
(*

```

Argument definitions:

**cad:** the **characterized\_action\_definition** that appears as the **definition** of the **action\_property** instances to return.

**prop\_name:** the string that appears as the **name** of the **action\_property** instances to return.

**5.2.5.2 get\_count\_of\_relating\_amr**

The **get\_count\_of\_relating\_amr** function returns the number of **action\_method\_relationship** instances in which the input **action\_method** appears as the **relating\_method** and the relationship is of all types which appear in the **amr\_types** input parameter.

EXPRESS specification:

```

*)
FUNCTION get_count_of_relating_amr (
    am:          action_method;
    amr_types:   SET OF STRING
): INTEGER;

RETURN (SIZEOF (QUERY (amr <* get_relating_amr (am) |
    (SIZEOF(amr_types * TYPEOF(amr)) =
    SIZEOF(amr_types)) )));
END_FUNCTION;
(*

```

Argument definitions:

**am:** the **action\_method** that appears as the **relating\_method** of the **action\_method\_relationship** instances to examine.

**amr\_types:** the set of desired type names for the **action\_method\_relationship** instances.

**5.2.5.3 get\_count\_of\_relating\_amr\_with\_name**

The **get\_count\_of\_relating\_amr\_with\_name** function returns the number of **action\_method\_relationship** instances in which the input **action\_method** appears as the **relating\_method**, the relationship is of all types which appear in the **amr\_types** input parameter, and the input parameter **amr\_name** appears as the **name** of the **action\_method\_relationship**.

EXPRESS specification:

```

*)

```

```

FUNCTION get_count_of_relating_amr_with_name (
    am:          action_method;
    amr_name:    STRING
    amr_types:   SET OF STRING
): INTEGER;

    RETURN (SIZEOF (QUERY (amr <* get_relating_amr (am) |
        ((amr.name = amr_name) AND
        (SIZEOF(amr_types * TYPEOF(amr)) =
        SIZEOF(amr_types))) ))));
END_FUNCTION;
(*

```

#### Argument definitions:

**am:** the **action\_method** that appears as the **relating\_method** of the **action\_method\_relationship** instances to examine.

**amr\_name:** the string that appears as the **name** of the **action\_method\_relationship** instances to examine.

**amr\_types:** the set of desired type names for the **action\_method\_relationship** instances.

### 5.2.5.4 get\_relating\_amr

The **get\_relating\_amr** function returns the set of **action\_method\_relationship** instances in which the input **action\_method** appears as the **relating\_method**.

#### EXPRESS specification:

```

*)
FUNCTION get_relating_amr (am: action_method)
    : SET OF action_method_relationship;

    RETURN (bag_to_set (USEDIN (am,
        'INTEGRATED_CNC_SCHEMA.ACTION_METHOD_RELATIONSHIP.RELATING_METHOD')));
END_FUNCTION;
(*

```

#### Argument definitions:

**am:** the **action\_method** that appears as the **relating\_method** of the **action\_method\_relationship** instances to return.

### 5.2.5.5 get\_resource\_property

The **get\_resource\_property** function returns the set of **resource\_property** instances that refer to the input **characterized\_resource\_definition** and have a **name** equal to the input parameter **prop\_name**.

EXPRESS specification:

```

*)
FUNCTION get_resource_property (
    crd:          characterized_resource_definition;
    prop_name:    STRING
): SET OF resource_property;

    RETURN (bag_to_set (QUERY (rp <*
        USEDIN (crd, 'INTEGRATED_CNC_SCHEMA.RESOURCE_PROPERTY.RESOURCE') |
        (rp.name = prop_name))));
END_FUNCTION;
(*

```

Argument definitions:

**crd:** the **characterized\_resource\_definition** that appears as the **resource** of the **resource\_property** instances to return.

**prop\_name:** the string that appears as the **name** of the **resource\_property** instances to return.

**5.2.5.6 get\_tool\_body\_item**

The **get\_tool\_body\_item** function returns the set of **representation\_item** instances that have a **name** equal to the input parameter **prop\_name** and appear in the **items** set of a **representation** of type **machining\_tool\_body\_representation** which describes a **resource\_property** with a **name** of 'tool body' and a **resource** which refers to the input **machining\_tool**.

EXPRESS specification:

```

*)
FUNCTION get_tool_body_item (
    mt :          machining_tool;
    prop_name :   STRING
): SET OF representation_item;

LOCAL
    props : SET OF resource_property;
    preps : SET OF resource_property_representation;
    items : SET OF representation_item;
END_LOCAL;

props := get_resource_property (mt, 'tool body');
REPEAT i := 1 TO HIINDEX(props);
    preps := preps + USEDIN (props[i], 'INTEGRATED_CNC_SCHEMA.'+
        'RESOURCE_PROPERTY_REPRESENTATION.PROPERTY');
END_REPEAT;

REPEAT i := 1 TO HIINDEX(preps);
    IF ('INTEGRATED_CNC_SCHEMA.MACHINING_TOOL_BODY_REPRESENTATION'
        IN TYPEOF (preps[i].representation))
    THEN

```

```

        items := items + preps[i].representation.items;
    END_IF;
END_REPEAT;

RETURN (bag_to_set (QUERY (it <* items | (it.name = prop_name))));
END_FUNCTION;
(*

```

Argument definitions:

**mt:** the **machining\_tool** that is related through a **resource\_property** to the **representation\_item** instances to return.

**prop\_name:** the string that appears as the **name** of the **representation\_item** instances to return.

### 5.2.5.7 verify\_angle\_measure\_action\_property

The **verify\_angle\_measure\_action\_property** function evaluates each **action\_property** that refers to the input **characterized\_action\_definition** and has a **name** equal to the input parameter **prop\_name**. The function returns true if and only if all such **action\_properties** have an associated **representation** in which the **items** set contains a **representation\_item** that is of type **measure\_representation\_item** and **plane\_angle\_measure\_with\_unit**.

EXPRESS specification:

```

*)
FUNCTION verify_angle_measure_action_property (
    cad:          characterized_action_definition;
    prop_name:    STRING
): LOGICAL;

    RETURN (verify_rep_item_for_action_property(cad, prop_name,
        ['INTEGRATED_CNC_SCHEMA.MEASURE_REPRESENTATION_ITEM',
        'INTEGRATED_CNC_SCHEMA.PLANE_ANGLE_MEASURE_WITH_UNIT']));
END_FUNCTION;
(*

```

Argument definitions:

**cad:** the **characterized\_action\_definition** that appears as the **definition** of the **action\_property** instances to examine.

**prop\_name:** the string that appears as the **name** of the **action\_property** instances to examine.

### 5.2.5.8 verify\_angle\_measure\_rep\_item

The **verify\_angle\_measure\_rep\_item** function returns true if and only if the **items** set of the input **representation** contains a **representation\_item** with a **name** equal to the input parameter **prop\_name** that is of type **measure\_representation\_item** and **plane\_angle\_measure\_with\_unit**.

EXPRESS specification:

```

*)
FUNCTION verify_angle_measure_rep_item (
    rep:          representation;
    prop_name:    STRING
): LOGICAL;

    RETURN (0 = SIZEOF (QUERY ( it <* rep.items |
        (it.name = prop_name) AND NOT (SIZEOF([
            'INTEGRATED_CNC_SCHEMA.MEASURE_REPRESENTATION_ITEM',
            'INTEGRATED_CNC_SCHEMA.PLANE_ANGLE_MEASURE_WITH_UNIT'] *
            TYPEOF(it)) = 2))));
END_FUNCTION;
(*

```

Argument definitions:

**rep:** the **representation** to examine.

**prop\_name:** the string that appears as the **name** of the **representation\_item** instances to examine.

**5.2.5.9 verify\_angle\_measure\_resource\_property**

The **verify\_angle\_measure\_resource\_property** function evaluates each **resource\_property** that refers to the input **characterized\_resource\_definition** and has a **name** equal to the input parameter **prop\_name**. The function returns true if and only if all such **resource\_properties** have an associated **representation** in which the **items** set contains a **representation\_item** that is of type **measure\_representation\_item** and **plane\_angle\_measure\_with\_unit**.

EXPRESS specification:

```

*)
FUNCTION verify_angle_measure_resource_property (
    crd :          characterized_resource_definition;
    prop_name :    STRING
): LOGICAL;

    RETURN (verify_rep_item_for_resource_property (crd, prop_name,
        ['INTEGRATED_CNC_SCHEMA.MEASURE_REPRESENTATION_ITEM',
        'INTEGRATED_CNC_SCHEMA.PLANE_ANGLE_MEASURE_WITH_UNIT']));
END_FUNCTION;
(*

```

Argument definitions:

**crd:** the **characterized\_resource\_definition** that appears as the **definition** of the **resource\_property** instances to examine.

**prop\_name:** the string that appears as the **name** of the **resource\_property** instances to examine.



### 5.2.5.10 verify\_angle\_measure\_tool\_body\_item

The **verify\_angle\_measure\_tool\_body\_item** function examines the **representation\_item** instances that have a **name** equal to the input parameter **prop\_name** and are associated with the input **machining\_tool** through a **resource\_property** with a **name** of 'tool body' and a **representation** of type **machining\_tool\_body\_representation**. The function returns true if and only if all such **representation\_item** instances are of type **measure\_representation\_item** and **plane\_angle\_measure\_with\_unit**.

#### EXPRESS specification:

```
*)
FUNCTION verify_angle_measure_tool_body_item (
    mt : machining_tool;
    prop_name : STRING
): LOGICAL;

    RETURN (verify_rep_item_for_tool_body(mt, prop_name,
        ['INTEGRATED_CNC_SCHEMA.MEASURE_REPRESENTATION_ITEM',
        'INTEGRATED_CNC_SCHEMA.PLANE_ANGLE_MEASURE_WITH_UNIT']));
END_FUNCTION;
(*
```

#### Argument definitions:

**mt:** the **machining\_tool** that is related through a **resource\_property** to the **representation\_item** instances to examine.

**prop\_name:** the string that appears as the **name** of the **representation\_item** instances to examine.

### 5.2.5.11 verify\_ballnose\_endmill\_dimensions

The **verify\_ballnose\_endmill\_dimensions** function examines the **representation\_item** instances that are associated with the input **machining\_tool** through a **resource\_property** with a **name** of 'tool body' and a **representation** of type **machining\_tool\_body\_representation**. It returns true if and only if the items meet certain value requirements.

#### EXPRESS specification:

```
*)
FUNCTION verify_ballnose_endmill_dimensions (
    mt : machining_tool
): LOGICAL;

    LOCAL
        rads : SET OF REPRESENTATION_ITEM :=
            get_tool_body_item (mt, 'edge radius');
        dias : SET OF REPRESENTATION_ITEM :=
            get_tool_body_item (mt, 'effective cutting diameter');
    END_LOCAL;
```

```

    RETURN ((0 = SIZEOF(rads)) OR
           ((1 = SIZEOF(rads)) AND
            (1 = SIZEOF(dias)) AND
            (rads[1].value_component = dias[1].value_component/2))
           );
END_FUNCTION;
(*

```

Argument definitions:

**mt:** the **machining\_tool** that is related through a **resource\_property** to the **representation\_item** instances to examine.

### 5.2.5.12 verify\_bullnose\_endmill\_dimensions

The **verify\_bullnose\_endmill\_dimensions** function examines the **representation\_item** instances that are associated with the input **machining\_tool** through a **resource\_property** with a **name** of 'tool body' and a **representation** of type **machining\_tool\_body\_representation**. It returns true if and only if the items meet certain value requirements.

EXPRESS specification:

```

*)
FUNCTION verify_bullnose_endmill_dimensions (
    mt : machining_tool
): LOGICAL;

LOCAL
    rads : SET OF REPRESENTATION_ITEM :=
        get_tool_body_item (mt, 'edge radius');
    dias : SET OF REPRESENTATION_ITEM :=
        get_tool_body_item (mt, 'effective cutting diameter');
END_LOCAL;

RETURN ((1 = SIZEOF(rads)) AND
        (1 = SIZEOF(dias)) AND
        (rads[1].value_component < dias[1].value_component/2)
        );
END_FUNCTION;
(*

```

Argument definitions:

**mt:** the **machining\_tool** that is related through a **resource\_property** to the **representation\_item** instances to examine.

### 5.2.5.13 verify\_count\_measure\_action\_property

The **verify\_count\_measure\_action\_property** function evaluates each **action\_property** that refers to the input **characterized\_action\_definition** and has a **name** equal to the input parameter **prop\_name**. The function returns true if and only if all such **action\_properties** have an associated **representation**

in which the **items** set contains a **measure\_representation\_item** with a **value\_component** of type **count\_measure**.

EXPRESS specification:

```

*)
FUNCTION verify_count_measure_action_property (
    cad:          characterized_action_definition;
    prop_name:    STRING
): LOGICAL;

    RETURN (0 = SIZEOF (QUERY (prop <* get_action_property (cad, prop_name) |
        NOT (
            (0 < SIZEOF (QUERY (prep <* USEDIN (prop, 'INTEGRATED_CNC_SCHEMA.' +
                'ACTION_PROPERTY_REPRESENTATION.PROPERTY') |
                    (0 < SIZEOF (QUERY (it <* prep.representation.items |
                        (('INTEGRATED_CNC_SCHEMA.MEASURE_REPRESENTATION_ITEM'
                            IN TYPEOF(it)) AND
                        ('INTEGRATED_CNC_SCHEMA.COUNT_MEASURE'
                            IN TYPEOF(it.value_component)))
                    )))
                )))
        )));
END_FUNCTION;
(*

```

Argument definitions:

**cad:** the **characterized\_action\_definition** that appears as the **definition** of the **action\_property** instances to examine.

**prop\_name:** the string that appears as the **name** of the **action\_property** instances to examine.

### 5.2.5.14 verify\_count\_measure\_rep\_item

The **verify\_count\_measure\_rep\_item** function returns true if and only if the **items** set of the input **representation** contains a **representation\_item** with a **name** equal to the input parameter **prop\_name** that is of type **measure\_representation\_item** and has a **value\_component** of type **count\_measure**.

EXPRESS specification:

```

*)
FUNCTION verify_count_measure_rep_item (
    rep:          representation;
    prop_name:    STRING
): LOGICAL;

    RETURN (0 = SIZEOF (QUERY ( it <* rep.items |
        (it.name = prop_name) AND NOT
        (('INTEGRATED_CNC_SCHEMA.MEASURE_REPRESENTATION_ITEM'

```

```

        IN TYPEOF(it)) AND
        ('INTEGRATED_CNC_SCHEMA.COUNT_MEASURE'
        IN TYPEOF(it.value_component)))));
END_FUNCTION;
(*

```

Argument definitions:

**rep:** the **representation** to examine.

**prop\_name:** the string that appears as the **name** of the **representation\_item** instances to examine.

### 5.2.5.15 verify\_count\_measure\_resource\_property

The **verify\_count\_measure\_resource\_property** function evaluates each **resource\_property** that refers to the input **characterized\_resource\_definition** and has a **name** equal to the input parameter **prop\_name**. The function returns true if and only if all such **resource\_properties** have an associated **representation** in which the **items** set contains a **measure\_representation\_item** with a **value\_component** of type **count\_measure**.

EXPRESS specification:

```

*)
FUNCTION verify_count_measure_resource_property (
    crd : characterized_resource_definition;
    prop_name : STRING
): LOGICAL;

    RETURN (0 = SIZEOF (QUERY (prop <* get_resource_property (crd, prop_name) |
        NOT (
            (0 < SIZEOF (QUERY (prep <* USEDIN (prop, 'INTEGRATED_CNC_SCHEMA.' +
                'RESOURCE_PROPERTY_REPRESENTATION.PROPERTY') |
                (0 < SIZEOF (QUERY (it <* prep.representation.items |
                    (('INTEGRATED_CNC_SCHEMA.MEASURE_REPRESENTATION_ITEM'
                    IN TYPEOF(it)) AND
                    ('INTEGRATED_CNC_SCHEMA.COUNT_MEASURE'
                    IN TYPEOF(it.value_component)))
                )))
            )))
        )));
END_FUNCTION;
(*

```

Argument definitions:

**crd:** the **characterized\_resource\_definition** that appears as the **definition** of the **resource\_property** instances to examine.

**prop\_name:** the string that appears as the **name** of the **resource\_property** instances to examine.

### 5.2.5.16 verify\_count\_measure\_tool\_body\_item

The **verify\_count\_measure\_tool\_body\_item** function examines the **representation\_item** instances that have a **name** equal to the input parameter **prop\_name** and are associated with the input **machining\_tool** through a **resource\_property** with a **name** of 'tool body' and a **representation** of type **machining\_tool\_body\_representation**. The function returns true if and only if all such **representation\_item** instances are of type **measure\_representation\_item** with a **value\_component** of type **count\_measure**.

#### EXPRESS specification:

```
*)
FUNCTION verify_count_measure_tool_body_item (
    mt :          machining_tool;
    prop_name :   STRING
): LOGICAL;

    RETURN (0 = SIZEOF (QUERY (it <* get_tool_body_item (mt, prop_name) | NOT
        (('INTEGRATED_CNC_SCHEMA.MEASURE_REPRESENTATION_ITEM'
         IN TYPEOF(it)) AND
         ('INTEGRATED_CNC_SCHEMA.COUNT_MEASURE'
         IN TYPEOF(it.value_component))))
    ));
END_FUNCTION;
(*
```

#### Argument definitions:

**mt:** the **machining\_tool** that is related through a **resource\_property** to the **representation\_item** instances to examine.

**prop\_name:** the string that appears as the **name** of the **representation\_item** instances to examine.

### 5.2.5.17 verify\_descriptive\_action\_property

The **verify\_descriptive\_action\_property** function evaluates each **action\_property** that refers to the input **characterized\_action\_definition** and has a **name** equal to the input parameter **prop\_name**. The function returns true if and only if all such **action\_properties** have an associated **representation** in which the **items** set contains a **representation\_item** that is of type **descriptive\_representation\_item**.

#### EXPRESS specification:

```
*)
FUNCTION verify_descriptive_action_property (
    cad:          characterized_action_definition;
    prop_name:    STRING
): LOGICAL;

    RETURN (verify_rep_item_for_action_property(cad, prop_name,
        ['INTEGRATED_CNC_SCHEMA.DESRIPTIVE_REPRESENTATION_ITEM']));
END_FUNCTION;
(*
```

Argument definitions:

**cad:** the **characterized\_action\_definition** that appears as the **definition** of the **action\_property** instances to examine.

**prop\_name:** the string that appears as the **name** of the **action\_property** instances to examine.

### 5.2.5.18 verify\_enumeration\_action\_property

The **verify\_enumeration\_action\_property** function evaluates each **action\_property** that refers to the input **characterized\_action\_definition** and has a **name** equal to the input parameter **prop\_name**. The function returns true if and only if all such **action\_properties** have an associated **representation** in which the **items** set contains a **descriptive\_representation\_item** with a **description** value that appears in the **prop\_values** set of strings.

EXPRESS specification:

```

*)
FUNCTION verify_enumeration_action_property (
    cad:          characterized_action_definition;
    prop_name:    STRING;
    prop_values:  SET OF STRING
): LOGICAL;

    RETURN (0 = SIZEOF (QUERY (prop <* get_action_property (cad, prop_name) |
        NOT (
            (0 < SIZEOF (QUERY (prep <* USEDIN (prop, 'INTEGRATED_CNC_SCHEMA.' +
                'ACTION_PROPERTY_REPRESENTATION.PROPERTY') |
                    (0 < SIZEOF (QUERY (it <* prep.representation.items |
                        (('INTEGRATED_CNC_SCHEMA.DESRIPTIVE_REPRESENTATION_ITEM'
                            IN TYPEOF(it)) AND
                            (it.description IN prop_values))
                    )))
                )))
        )));
END_FUNCTION;
(*

```

Argument definitions:

**cad:** the **characterized\_action\_definition** that appears as the **definition** of the **action\_property** instances to examine.

**prop\_name:** the string that appears as the **name** of the **action\_property** instances to examine.

**prop\_values:** the set of string values that the **description** attribute of a **descriptive\_representation\_item** is to be compared against.

### 5.2.5.19 verify\_enumeration\_resource\_property

The **verify\_enumeration\_resource\_property** function evaluates each **resource\_property** that refers to the input **characterized\_resource\_definition** and has a **name** equal to the input parameter **prop\_name**. The function returns true if and only if all such **resource\_properties** have an associated **representation** in which the **items** set contains a **descriptive\_representation\_item** with a **description** value that appears in the **prop\_values** set of strings.

#### EXPRESS specification:

```
*)
FUNCTION verify_enumeration_resource_property (
  crd : characterized_resource_definition;
  prop_name : STRING;
  prop_values : SET OF STRING
): LOGICAL;

  RETURN (0 = SIZEOF (QUERY (prop <* get_resource_property (crd, prop_name) |
    NOT (
      (0 < SIZEOF (QUERY (prep <* USEDIN (prop, 'INTEGRATED_CNC_SCHEMA.' +
        'RESOURCE_PROPERTY_REPRESENTATION.PROPERTY') |
          (0 < SIZEOF (QUERY (it <* prep.representation.items |
            (('INTEGRATED_CNC_SCHEMA.DESRIPTIVE_REPRESENTATION_ITEM'
              IN TYPEOF(it)) AND
              (it.description IN prop_values))
            )))
          )))
      )));
END_FUNCTION;
(*
```

#### Argument definitions:

**crd:** the **characterized\_resource\_definition** that appears as the **definition** of the **resource\_property** instances to examine.

**prop\_name:** the string that appears as the **name** of the **resource\_property** instances to examine.

**prop\_values:** the set of string values that the **description** attribute of a **descriptive\_representation\_item** is to be compared against.

### 5.2.5.20 verify\_enumeration\_measure\_tool\_body\_item

The **verify\_enumeration\_measure\_tool\_body\_item** function examines the **representation\_item** instances that have a **name** equal to the input parameter **prop\_name** and are associated with the input **machining\_tool** through a **resource\_property** with a **name** of 'tool body' and a **representation** of type **machining\_tool\_body\_representation**. The function returns true if and only if all such

**representation\_item** instances are of type **descriptive\_representation\_item** with a **description** value that appears in the **prop\_values** set of strings.

EXPRESS specification:

```
*)
FUNCTION verify_enumeration_tool_body_item (
    mt :          machining_tool;
    prop_name :   STRING;
    prop_values : SET OF STRING
): LOGICAL;

    RETURN (0 = SIZEOF (QUERY (it <* get_tool_body_item (mt, prop_name) | NOT
        (('INTEGRATED_CNC_SCHEMA.DESRIPTIVE_REPRESENTATION_ITEM'
            IN TYPEOF(it)) AND
            (it.description IN prop_values))
        )))
);
END_FUNCTION;
(*
```

Argument definitions:

**mt:** the **machining\_tool** that is related through a **resource\_property** to the **representation\_item** instances to examine.

**prop\_name:** the string that appears as the **name** of the **representation\_item** instances to examine.

**prop\_values:** the set of string values that the **description** attribute of a **descriptive\_representation\_item** is to be compared against.

### 5.2.5.21 verify\_length\_measure\_action\_property

The **verify\_length\_measure\_action\_property** function evaluates each **action\_property** that refers to the input **characterized\_action\_definition** and has a **name** equal to the input parameter **prop\_name**. The function returns true if and only if all such **action\_properties** have an associated **representation** in which the **items** set contains a **representation\_item** that is of type **measure\_representation\_item** and **length\_measure\_with\_unit**.

EXPRESS specification:

```
*)
FUNCTION verify_length_measure_action_property (
    cad:          characterized_action_definition;
    prop_name:    STRING
): LOGICAL;

    RETURN (verify_rep_item_for_action_property (cad, prop_name,
        ['INTEGRATED_CNC_SCHEMA.MEASURE_REPRESENTATION_ITEM',
        'INTEGRATED_CNC_SCHEMA.LENGTH_MEASURE_WITH_UNIT']));
END_FUNCTION;
(*
```



Argument definitions:

**cad:** the **characterized\_action\_definition** that appears as the **definition** of the **action\_property** instances to examine.

**prop\_name:** the string that appears as the **name** of the **action\_property** instances to examine.

**5.2.5.22 verify\_length\_measure\_rep\_item**

The **verify\_length\_measure\_rep\_item** function returns true if and only if the **items** set of the input **representation** contains a **representation\_item** with a **name** equal to the input parameter **prop\_name** that is of type **measure\_representation\_item** and **length\_measure\_with\_unit**.

EXPRESS specification:

```
*)
FUNCTION verify_length_measure_rep_item (
    rep:          representation;
    prop_name:    STRING
): LOGICAL;

    RETURN (0 = SIZEOF (QUERY ( it <* rep.items |
        (it.name = prop_name) AND NOT (SIZEOF([
            'INTEGRATED_CNC_SCHEMA.MEASURE_REPRESENTATION_ITEM',
            'INTEGRATED_CNC_SCHEMA.LENGTH_MEASURE_WITH_UNIT'] *
            TYPEOF(it) = 2))));
END_FUNCTION;
(*
```

Argument definitions:

**rep:** the **representation** to examine.

**prop\_name:** the string that appears as the **name** of the **representation\_item** instances to examine.

**5.2.5.23 verify\_length\_measure\_resource\_property**

The **verify\_length\_measure\_resource\_property** function evaluates each **resource\_property** that refers to the input **characterized\_resource\_definition** and has a **name** equal to the input parameter **prop\_name**. The function returns true if and only if all such **resource\_properties** have an associated **representation** in which the **items** set contains a **representation\_item** that is of type **measure\_representation\_item** and **length\_measure\_with\_unit**.

EXPRESS specification:

```
*)
FUNCTION verify_length_measure_resource_property (
    crd:          characterized_resource_definition;
    prop_name:    STRING
): LOGICAL;
```

```

RETURN (verify_rep_item_for_resource_property (crd, prop_name,
        ['INTEGRATED_CNC_SCHEMA.MEASURE_REPRESENTATION_ITEM',
         'INTEGRATED_CNC_SCHEMA.LENGTH_MEASURE_WITH_UNIT']));
END_FUNCTION;
(*)

```

Argument definitions:

**crd:** the **characterized\_resource\_definition** that appears as the **definition** of the **resource\_property** instances to examine.

**prop\_name:** the string that appears as the **name** of the **resource\_property** instances to examine.

### 5.2.5.24 verify\_length\_measure\_tool\_body\_item

The **verify\_length\_measure\_tool\_body\_item** function examines the **representation\_item** instances that have a **name** equal to the input parameter **prop\_name** and are associated with the input **machining\_tool** through a **resource\_property** with a **name** of 'tool body' and a **representation** of type **machining\_tool\_body\_representation**. The function returns true if and only if all such **representation\_item** instances are of type **measure\_representation\_item** and **length\_measure\_with\_unit**.

EXPRESS specification:

```

*)
FUNCTION verify_length_measure_tool_body_item (
    mt :      machining_tool;
    prop_name : STRING
): LOGICAL;

RETURN (verify_rep_item_for_tool_body(mt, prop_name,
        ['INTEGRATED_CNC_SCHEMA.MEASURE_REPRESENTATION_ITEM',
         'INTEGRATED_CNC_SCHEMA.LENGTH_MEASURE_WITH_UNIT']));
END_FUNCTION;
(*)

```

Argument definitions:

**mt:** the **machining\_tool** that is related through a **resource\_property** to the **representation\_item** instances to examine.

**prop\_name:** the string that appears as the **name** of the **representation\_item** instances to examine.

### 5.2.5.25 verify\_linear\_speed\_measure\_rep\_item

The **verify\_linear\_speed\_measure\_rep\_item** function returns true if and only if the **items** set of the input **representation** contains a **representation\_item** with a **name** equal to the input parameter **prop\_name** that is of type **measure\_representation\_item** and has a **value\_component** of type **numeric\_measure**.

EXPRESS specification:

```

*)
FUNCTION verify_linear_speed_measure_rep_item (
    rep:          representation;
    prop_name:    STRING
): LOGICAL;

    RETURN (0 = SIZEOF (QUERY ( it <* rep.items |
        (it.name = prop_name) AND NOT
        (('INTEGRATED_CNC_SCHEMA.MEASURE_REPRESENTATION_ITEM'
            IN TYPEOF(it)) AND
        ('INTEGRATED_CNC_SCHEMA.NUMERIC_MEASURE'
            IN TYPEOF(it.value_component))))));
END_FUNCTION;
(*

```

Argument definitions:

**rep:** the **representation** to examine.

**prop\_name:** the string that appears as the **name** of the **representation\_item** instances to examine.

**5.2.5.26 verify\_numeric\_measure\_action\_property**

The **verify\_numeric\_measure\_action\_property** function evaluates each **action\_property** that refers to the input **characterized\_action\_definition** and has a **name** equal to the input parameter **prop\_name**. The function returns true if and only if all such **action\_properties** have an associated **representation** in which the **items** set contains a **representation\_item** that is of type **measure\_representation\_item** and has a **value\_component** of type **numeric\_measure**.

EXPRESS specification:

```

*)
FUNCTION verify_numeric_measure_action_property (
    cad:          characterized_action_definition;
    prop_name:    STRING
): LOGICAL;

    -- All properties have matching representations.  The reason we test
    -- for "nothing matching the negation" rather than "something matching
    -- the positive" is so that we return true if there are no properties.
    --
    RETURN (0 = SIZEOF (QUERY (prop <* get_action_property (cad, prop_name) |

        -- property has no matching representations
        NOT (

            -- there is at least one rep with matching rep items
            (0 < SIZEOF (QUERY (prep <* USEDIN (prop, 'INTEGRATED_CNC_SCHEMA.' +
                'ACTION_PROPERTY_REPRESENTATION.PROPERTY') |

```

```

-- property representation has at least one matching rep item
(0 < SIZEOF (QUERY (it <* prep.representation.items |
  (('INTEGRATED_CNC_SCHEMA.MEASURE_REPRESENTATION_ITEM'
    IN TYPEOF(it)) AND
    ('INTEGRATED_CNC_SCHEMA.NUMERIC_MEASURE'
    IN TYPEOF(it.value_component))))
  )))
  )))
  )));
END_FUNCTION;
(*

```

Argument definitions:

**cad:** the **characterized\_action\_definition** that appears as the **definition** of the **action\_property** instances to examine.

**prop\_name:** the string that appears as the **name** of the **action\_property** instances to examine.

**5.2.5.27 verify\_optional\_action\_property**

The **verify\_optional\_action\_property** function returns true if and only if there is at most one **action\_property** that refers to the input **characterized\_action\_definition** and has a **name** equal to the input parameter **prop\_name**.

EXPRESS specification:

```

*)
FUNCTION verify_optional_action_property (
  cad:          characterized_action_definition;
  prop_name:    STRING
): LOGICAL;

  RETURN (1 >= SIZEOF (get_action_property (cad, prop_name)));
END_FUNCTION;
(*

```

Argument definitions:

**cad:** the **characterized\_action\_definition** that appears as the **definition** of the **action\_property** instances to examine.

**prop\_name:** the string that appears as the **name** of the **action\_property** instances to examine.

**5.2.5.28 verify\_optional\_in\_process\_geometry**

The **verify\_optional\_in\_process\_geometry** function returns true if and only if the input **machining\_process\_executable** satisfies the following conditions:

- the **machining\_process\_executable** is **definition** of at most one **action\_property** with a **name** of 'as-is shape', and the **representation** used to describe the **action\_property** is of type **shape\_representation**;
- the **machining\_process\_executable** is **definition** of at most one **action\_property** with a **name** of 'to-be shape', and the **representation** used to describe the **action\_property** is of type **shape\_representation**;
- the **machining\_process\_executable** is **definition** of at most one **action\_property** with a **name** of 'removal shape', and the **representation** used to describe the **action\_property** is of type **shape\_representation**.

EXPRESS specification:

```

*)
FUNCTION verify_optional_in_process_geometry (
    mpe:          machining_process_executable
): LOGICAL;

RETURN
((verify_optional_action_property (mpe, 'as-is shape')) AND
 (verify_optional_action_property (mpe, 'to-be shape')) AND
 (verify_optional_action_property (mpe, 'removal shape')) AND

 -- All properties need advanced brep shape reps
(0 = SIZEOF (QUERY (prop <*
    USEDIN (mpe, 'INTEGRATED_CNC_SCHEMA.ACTION_PROPERTY.DEFINITION') |
    ((prop.name IN ['as-is shape', 'to-be shape', 'removal shape']) AND
    (0 = SIZEOF (QUERY (prep <* USEDIN (prop, 'INTEGRATED_CNC_SCHEMA.' +
    'ACTION_PROPERTY_REPRESENTATION.PROPERTY') |
    ('INTEGRATED_CNC_SCHEMA.SHAPE_REPRESENTATION'
    IN TYPEOF (prep.representation))))))
)))
);
END_FUNCTION;
(*

```

Argument definitions:

**mpe:** the **machining\_process\_executable** to examine.

### 5.2.5.29 verify\_optional\_relating\_amr

The **verify\_optional\_relating\_amr** function returns true if and only if there is at most one **action\_method\_relationship** in which the input **action\_method** appears as the **relating\_method** and the **action\_method\_relationship** is of all types which appear in the **amr\_types** input parameter.

EXPRESS specification:

```

*)
FUNCTION verify_optional_relating_amr (

```

```

    am:                action_method;
    amr_types:         SET OF STRING
  ): LOGICAL;

    RETURN (1 >= get_count_of_relating_amr (am, amr_types));
END_FUNCTION;
(*)

```

Argument definitions:

**am:** the **action\_method** that appears as the **relating\_method** of the **action\_method\_relationship** instances to examine.

**amr\_types:** the set of desired type names for the **action\_method\_relationship** instances.

**5.2.5.30 verify\_optional\_relating\_amr\_with\_name**

The **verify\_optional\_relating\_amr\_with\_name** function returns true if and only if there is at most one **action\_method\_relationship** in which the input **action\_method** appears as the **relating\_method**, the **action\_method\_relationship** is of all types which appear in the **amr\_types** input parameter, and the input parameter **amr\_name** appears as the **name** of the **action\_method\_relationship**.

EXPRESS specification:

```

*)
FUNCTION verify_optional_relating_amr_with_name (
    am:                action_method;
    amr_name:          STRING
    amr_types:         SET OF STRING
  ): LOGICAL;

    RETURN (1 >= get_count_of_relating_amr_with_name (
        am, amr_name, amr_types));
END_FUNCTION;
(*)

```

Argument definitions:

**am:** the **action\_method** that appears as the **relating\_method** of the **action\_method\_relationship** instances to examine.

**amr\_name:** the string that appears as the **name** of the **action\_method\_relationship** instances to examine.

**amr\_types:** the set of desired type names for the **action\_method\_relationship** instances.

### 5.2.5.31 verify\_optional\_rep\_item

The **verify\_optional\_rep\_item** function returns true if and only if the **items** set of the input **representation** contains at most one **representation\_item** with a **name** equal to the input parameter **prop\_name**.

EXPRESS specification:

```
*)
FUNCTION verify_optional_rep_item (
    rep:          representation;
    prop_name:    STRING
): LOGICAL;

    RETURN (1 >= SIZEOF (QUERY ( it <* rep.items |
        (it.name = prop_name))));
END_FUNCTION;
(*
```

Argument definitions:

**rep:** the **representation** to examine.

**prop\_name:** the string that appears as the **name** of the **representation\_item** instances to examine.

### 5.2.5.32 verify\_optional\_resource\_property

The **verify\_optional\_resource\_property** function returns true if and only if there is at most one **resource\_property** that refers to the input **characterized\_resource\_definition** and has a **name** equal to the input parameter **prop\_name**.

EXPRESS specification:

```
*)
FUNCTION verify_optional_resource_property (
    crd:          characterized_resource_definition;
    prop_name:    STRING
): LOGICAL;

    RETURN (1 >= SIZEOF (get_resource_property (crd, prop_name)));
END_FUNCTION;
(*
```

Argument definitions:

**crd:** the **characterized\_resource\_definition** that appears as the **definition** of the **resource\_property** instances to examine.

**prop\_name:** the string that appears as the **name** of the **resource\_property** instances to examine.

### 5.2.5.33 verify\_optional\_tool\_body\_item

The **verify\_optional\_tool\_body\_item** function examines the **representation\_item** instances that have a **name** equal to the input parameter **prop\_name** and are associated with the input **machining\_tool** through a **resource\_property** with a **name** of 'tool body' and a **representation** of type **machining\_tool\_body\_representation**. The function returns true if and only if there is at most one such **representation\_item** instance.

#### EXPRESS specification:

```

*)
FUNCTION verify_optional_tool_body_item (
    mt : machining_tool;
    prop_name : STRING
): LOGICAL;

    RETURN (1 >= SIZEOF (get_tool_body_item (mt, prop_name)));
END_FUNCTION;
(*

```

#### Argument definitions:

**mt:** the **machining\_tool** that is related through a **resource\_property** to the **representation\_item** instances to examine.

**prop\_name:** the string that appears as the **name** of the **representation\_item** instances to examine.

### 5.2.5.34 verify\_pressure\_measure\_action\_property

The **verify\_pressure\_measure\_action\_property** function evaluates each **action\_property** that refers to the input **characterized\_action\_definition** and has a **name** equal to the input parameter **prop\_name**. The function returns true if and only if all such **action\_properties** have an associated **representation** in which the **items** set contains a **representation\_item** that is of type **measure\_representation\_item** and has a **value\_component** of type **numeric\_measure**.

#### EXPRESS specification:

```

*)
FUNCTION verify_pressure_measure_action_property (
    cad: characterized_action_definition;
    prop_name: STRING
): LOGICAL;

    RETURN (verify_numeric_measure_action_property (cad, prop_name));
END_FUNCTION;
(*

```



Argument definitions:

**cad:** the **characterized\_action\_definition** that appears as the **definition** of the **action\_property** instances to examine.

**prop\_name:** the string that appears as the **name** of the **action\_property** instances to examine.

**5.2.5.35 verify\_ratio\_measure\_action\_property**

The **verify\_ratio\_measure\_action\_property** function evaluates each **action\_property** that refers to the input **characterized\_action\_definition** and has a **name** equal to the input parameter **prop\_name**. The function returns true if and only if all such **action\_properties** have an associated **representation** in which the **items** set contains a **representation\_item** that is of type **measure\_representation\_item** and **ratio\_measure\_with\_unit**.

EXPRESS specification:

```
*)
FUNCTION verify_ratio_measure_action_property (
    cad:          characterized_action_definition;
    prop_name:    STRING
): LOGICAL;

    RETURN (verify_rep_item_for_action_property (cad, prop_name,
        ['INTEGRATED_CNC_SCHEMA.MEASURE_REPRESENTATION_ITEM',
        'INTEGRATED_CNC_SCHEMA.RATIO_MEASURE_WITH_UNIT']));
END_FUNCTION;
(*
```

Argument definitions:

**cad:** the **characterized\_action\_definition** that appears as the **definition** of the **action\_property** instances to examine.

**prop\_name:** the string that appears as the **name** of the **action\_property** instances to examine.

**5.2.5.36 verify\_ratio\_measure\_rep\_item**

The **verify\_ratio\_measure\_rep\_item** function returns true if and only if the **items** set of the input **representation** contains a **representation\_item** with a **name** equal to the input parameter **prop\_name** that is of type **measure\_representation\_item** and **ratio\_measure\_with\_unit**.

EXPRESS specification:

```
*)
FUNCTION verify_ratio_measure_rep_item (
    rep:          representation;
    prop_name:    STRING
): LOGICAL;
```

```

RETURN (0 = SIZEOF (QUERY ( it <* rep.items |
    (it.name = prop_name) AND NOT (SIZEOF([
        'INTEGRATED_CNC_SCHEMA.MEASURE_REPRESENTATION_ITEM',
        'INTEGRATED_CNC_SCHEMA.RATIO_MEASURE_WITH_UNIT'] *
        TYPEOF(it)) = 2))));
END_FUNCTION;
(*

```

Argument definitions:

**rep:** the **representation** to examine.

**prop\_name:** the string that appears as the **name** of the **representation\_item** instances to examine.

### 5.2.5.37 verify\_related\_type\_for\_amr

The **verify\_related\_type\_for\_amr** function evaluates the **action\_method\_relationship** instances in which the input **action\_method** appears as **relating\_method**, and the relationship is of all types which appear in the **amr\_types** input parameter. The function returns true if and only if all such **action\_method\_relationship** have a **related\_method** that is of all types which appear in the **types** input parameter.

EXPRESS specification:

```

*)
FUNCTION verify_related_type_for_amr (
    am:          action_method;
    amr_types:   SET OF STRING
    types:      SET OF STRING
): LOGICAL;

RETURN (0 = SIZEOF (QUERY (amr <* get_relating_amr (am) |
    (SIZEOF(amr_types * TYPEOF(amr)) =
    SIZEOF(amr_types)) AND
    NOT
    (SIZEOF(types * TYPEOF(amr.related_method)) =
    SIZEOF(types) ) ));
END_FUNCTION;
(*

```

Argument definitions:

**am:** the **action\_method** that appears as the **relating\_method** of the **action\_method\_relationship** instances to examine.

**amr\_types:** the set of desired type names for the **action\_method\_relationship** instances.

**types:** the set of desired type names for the **action\_method** that appears as the **related\_method** of the **action\_method\_relationship** instances.

### 5.2.5.38 verify\_related\_type\_for\_amr\_with\_name

The **verify\_related\_type\_for\_amr\_with\_name** function evaluates the **action\_method\_relationship** instances in which the input **action\_method** appears as the **relating\_method**, the relationship is of all types which appear in the **amr\_types** input parameter, and the **name** is equal to the **amr\_name** input parameter. The function returns true if and only if all such **action\_method\_relationship** have a **related\_method** that is of all types which appear in the **types** input parameter.

EXPRESS specification:

```

*)
FUNCTION verify_related_type_for_amr_with_name (
    am:          action_method;
    amr_name:    STRING;
    amr_types:   SET OF STRING
    types:      SET OF STRING
): LOGICAL;

    RETURN (0 = SIZEOF (QUERY (amr <* get_relating_amr (am) |
        (amr.name = amr_name) AND
        (SIZEOF(amr_types * TYPEOF(amr)) =
        SIZEOF(amr_types)) AND
        NOT
        (SIZEOF(types * TYPEOF(amr.related_method)) =
        SIZEOF(types)) ))) );
END_FUNCTION;
(*

```

Argument definitions:

**am:** the **action\_method** that appears as the **relating\_method** of the **action\_method\_relationship** instances to examine.

**amr\_name:** the string that appears as the **name** of the **action\_method\_relationship** instances to examine.

**amr\_types:** the set of desired type names for the **action\_method\_relationship** instances.

**types:** the set of desired type names for the **action\_method** that appears as the **related\_method** of the **action\_method\_relationship** instances.

### 5.2.5.39 verify\_rep\_item\_for\_action\_property

The **verify\_rep\_item\_for\_action\_property** function evaluates each **action\_property** that refers to the input **characterized\_action\_definition** and has a **name** equal to the input parameter **prop\_name**. The function returns true if and only if all such **action\_properties** have an associated **representation** in which the **items** set contains a **representation\_item** that is of all types which appear in the **rep\_item\_types** input parameter.

EXPRESS specification:

```

*)
FUNCTION verify_rep_item_for_action_property (
    cad:          characterized_action_definition;
    prop_name:    STRING;
    rep_item_types: SET OF STRING
): LOGICAL;

-- All properties have matching representations. The reason we test
-- for "nothing matching the negation" rather than "something matching
-- the positive" is so that we return true if there are no properties.
--
RETURN (0 = SIZEOF (QUERY (prop <* get_action_property (cad, prop_name) |
    NOT (
        (0 < SIZEOF (QUERY (prep <* USEDIN (prop, 'INTEGRATED_CNC_SCHEMA.' +
            'ACTION_PROPERTY_REPRESENTATION.PROPERTY') |
            (0 < SIZEOF (QUERY (it <* prep.representation.items |
                (SIZEOF (rep_item_types * TYPEOF(it)) =
                    SIZEOF (rep_item_types))))
            )))
        ))
    ));
END_FUNCTION;
(*

```

Argument definitions:

**cad:** the **characterized\_action\_definition** that appears as the **definition** of the **action\_property** instances to examine.

**prop\_name:** the string that appears as the **name** of the **action\_property** instances to examine.

**rep\_item\_types:** the set of desired **representation\_item** type names.

### 5.2.5.40 verify\_rep\_item\_for\_resource\_property

The **verify\_rep\_item\_for\_resource\_property** function evaluates each **resource\_property** that refers to the input **characterized\_resource\_definition** and has a **name** equal to the input parameter **prop\_name**. The function returns true if and only if all such **resource\_properties** have an associated **representation** in which the **items** set contains a **representation\_item** that is of all types which appear in the **rep\_item\_types** input parameter.

EXPRESS specification:

```

*)
FUNCTION verify_rep_item_for_resource_property (
    crd:          characterized_resource_definition;
    prop_name:    STRING;
    rep_item_types: SET OF STRING
): LOGICAL;

```

```

RETURN (0 = SIZEOF (QUERY (prop <* get_resource_property (crd, prop_name) |
    NOT (0 < SIZEOF (QUERY (prep <* USEDIN (prop, 'INTEGRATED_CNC_SCHEMA.' +
        'RESOURCE_PROPERTY_REPRESENTATION.PROPERTY') |

        (0 < SIZEOF (QUERY (it <* prep.representation.items |
            (SIZEOF (rep_item_types * TYPEOF(it)) =
                SIZEOF (rep_item_types))))))
        )))
    )))
END_FUNCTION;
(*

```

Argument definitions:

**cad:** the **characterized\_resource\_definition** that appears as the **definition** of the **resource\_property** instances to examine.

**prop\_name:** the string that appears as the **name** of the **resource\_property** instances to examine.

**rep\_item\_types:** the set of desired **representation\_item** type names.

### 5.2.5.41 verify\_rep\_item\_for\_tool\_body

The **verify\_rep\_item\_for\_tool\_body** function examines the **representation\_item** instances that have a **name** equal to the input parameter **prop\_name** and are associated with the input **machining\_tool** through a **resource\_property** with a **name** of 'tool body' and a **representation** of type **machining\_tool\_body\_representation**. The function returns true if and only if all such **representation\_item** instances are of all types which appear in the **rep\_item\_types** input parameter.

EXPRESS specification:

```

*)
FUNCTION verify_rep_item_for_tool_body (
    mt :          machining_tool;
    prop_name :   STRING;
    rep_item_types : SET OF STRING
): LOGICAL;

    RETURN (0 = SIZEOF (QUERY (it <* get_tool_body_item (mt, prop_name) | NOT
        ((SIZEOF (rep_item_types * TYPEOF(it)) =
            SIZEOF (rep_item_types))))
        )))
END_FUNCTION;
(*

```

Argument definitions:

**mt:** the **machining\_tool** that is related through a **resource\_property** to the **representation\_item** instances to examine.

**prop\_name:** the string that appears as the **name** of the **representation\_item** instances to examine.

**rep\_item\_types:** the set of desired **representation\_item** type names.

### 5.2.5.42 verify\_rep\_name\_for\_action\_property

The **verify\_rep\_name\_for\_action\_property** function evaluates each **action\_property** that refers to the input **characterized\_action\_definition** and has a **name** equal to the input parameter **prop\_name**. The function returns true if and only if all such **action\_properties** have an associated **representation** with a **name** that appear in the **desc\_names** input parameter.

#### EXPRESS specification:

```

*)
FUNCTION verify_rep_name_for_action_property (
    cad:                characterized_action_definition;
    prop_name:          STRING;
    desc_names:         SET OF STRING
): LOGICAL;

    RETURN (0 = SIZEOF (QUERY (prop < *
        get_action_property (cad, prop_name) | NOT
        (0 < SIZEOF (QUERY (prep < * USEDIN (prop, 'INTEGRATED_CNC_SCHEMA.' +
            'ACTION_PROPERTY_REPRESENTATION.PROPERTY') |
            (prep.representation.name IN desc_names)
            )))
        )))
END_FUNCTION;
(*

```

#### Argument definitions:

**cad:** the **characterized\_action\_definition** that appears as the **definition** of the **action\_property** instances to examine.

**prop\_name:** the string that appears as the **name** of the **action\_property** instances to examine.

**desc\_names:** the set of string values to compare against the **name** of each **representation**.

### 5.2.5.43 verify\_rep\_type\_for\_action\_property

The **verify\_rep\_type\_for\_action\_property** function evaluates each **action\_property** that refers to the input **characterized\_action\_definition** and has a **name** equal to the input parameter **prop\_name**. The function returns true if and only if all such **action\_properties** have an associated **representation** that is of all types which appear in the **rep\_types** input parameter.

#### EXPRESS specification:

```

*)
FUNCTION verify_rep_type_for_action_property (

```

```

cad:          characterized_action_definition;
prop_name:    STRING;
rep_types:    SET OF STRING
): LOGICAL;

RETURN (0 = SIZEOF (QUERY (prop <*
  get_action_property (cad, prop_name) | NOT
  (0 < SIZEOF (QUERY (prep <* USEDIN (prop, 'INTEGRATED_CNC_SCHEMA.'+
    'ACTION_PROPERTY_REPRESENTATION.PROPERTY') |

    (SIZEOF(rep_types * TYPEOF(preparepresentation)) =
    SIZEOF(rep_types))
  )))
  ));
END_FUNCTION;
(*

```

#### Argument definitions:

**cad:** the **characterized\_action\_definition** that appears as the **definition** of the **action\_property** instances to examine.

**prop\_name:** the string that appears as the **name** of the **action\_property** instances to examine.

**rep\_types:** the set of desired **representation** type names.

### 5.2.5.44 verify\_rep\_type\_for\_resource\_property

The **verify\_rep\_type\_for\_resource\_property** function evaluates each **resource\_property** that refers to the input **characterized\_resource\_definition** and has a **name** equal to the input parameter **prop\_name**. The function returns true if and only if all such **resource\_properties** have an associated **representation** that is of all types which appear in the **rep\_types** input parameter.

#### EXPRESS specification:

```

*)
FUNCTION verify_rep_type_for_resource_property (
  crd:          characterized_resource_definition;
  prop_name:    STRING;
  rep_types:    SET OF STRING
): LOGICAL;

RETURN (0 = SIZEOF (QUERY (prop <*
  get_resource_property (crd, prop_name) | NOT
  (0 < SIZEOF (QUERY (prep <* USEDIN (prop, 'INTEGRATED_CNC_SCHEMA.'+
    'RESOURCE_PROPERTY_REPRESENTATION.PROPERTY') |

    (SIZEOF(rep_types * TYPEOF(preparepresentation)) =
    SIZEOF(rep_types))
  )))
  ));
END_FUNCTION;
(*

```

Argument definitions:

**crd:** the **characterized\_resource\_definition** that appears as the **definition** of the **resource\_property** instances to examine.

**prop\_name:** the string that appears as the **name** of the **resource\_property** instances to examine.

**rep\_types:** the set of desired **representation** type names.

### 5.2.5.45 verify\_required\_action\_property

The **verify\_required\_action\_property** function returns true if and only if there is exactly one **action\_property** that refers to the input **characterized\_action\_definition** and has a **name** equal to the input parameter **prop\_name**.

EXPRESS specification:

```
*)  
FUNCTION verify_required_action_property (  
    cad:          characterized_action_definition;  
    prop_name:    STRING  
): LOGICAL;  
  
    RETURN (1 = SIZEOF (get_action_property (cad, prop_name)));  
END_FUNCTION;  
(*
```

Argument definitions:

**cad:** the **characterized\_action\_definition** that appears as the **definition** of the **action\_property** instances to examine.

**prop\_name:** the string that appears as the **name** of the **action\_property** instances to examine.

### 5.2.5.46 verify\_required\_relating\_amr

The **verify\_required\_relating\_amr** function returns true if and only if there is exactly one **action\_method\_relationship** in which the input **action\_method** appears as the **relating\_method** and the **action\_method\_relationship** is of all types which appear in the **amr\_types** input parameter.

EXPRESS specification:

```
*)  
FUNCTION verify_required_relating_amr (  
    am:          action_method;  
    amr_types:   SET OF STRING  
): LOGICAL;
```



```

    RETURN (1 = get_count_of_relating_amr (am, amr_types));
END_FUNCTION;
(*)

```

Argument definitions:

**am:** the **action\_method** that appears as the **relating\_method** of the **action\_method\_relationship** instances to examine.

**amr\_types:** the set of desired type names for the **action\_method\_relationship** instances.

### 5.2.5.47 verify\_required\_relating\_amr\_with\_name

The **verify\_required\_relating\_amr\_with\_name** function returns true if and only if there is exactly one **action\_method\_relationship** in which the input **action\_method** appears as the **relating\_method**, the **action\_method\_relationship** is of all types which appear in the **amr\_types** input parameter, and the input parameter **amr\_name** appears as the **name** of the **action\_method\_relationship**.

EXPRESS specification:

```

*)
FUNCTION verify_required_relating_amr_with_name (
    am:          action_method;
    amr_name:    STRING
    amr_types:   SET OF STRING
): LOGICAL;

    RETURN (1 = get_count_of_relating_amr_with_name (
        am, amr_name, amr_types));
END_FUNCTION;
(*)

```

Argument definitions:

**am:** the **action\_method** that appears as the **relating\_method** of the **action\_method\_relationship** instances to examine.

**amr\_name:** the string that appears as the **name** of the **action\_method\_relationship** instances to examine.

**amr\_types:** the set of desired type names for the **action\_method\_relationship** instances.

### 5.2.5.48 verify\_required\_rep\_item

The **verify\_required\_rep\_item** function returns true if and only if the **items** set of the input **representation** contains exactly one **representation\_item** with a **name** equal to the input parameter **prop\_name**.

EXPRESS specification:

```

*)
FUNCTION verify_required_rep_item (
    rep:          representation;
    prop_name:    STRING
): LOGICAL;

    RETURN (1 = SIZEOF (QUERY ( it <* rep.items |
        (it.name = prop_name))));
END_FUNCTION;
(*

```

Argument definitions:

**rep:** the **representation** to examine.

**prop\_name:** the string that appears as the **name** of the **representation\_item** instances to examine.

### 5.2.5.49 verify\_required\_resource\_property

The **verify\_required\_resource\_property** function returns true if and only if there is exactly one **resource\_property** that refers to the input **characterized\_resource\_definition** and has a **name** equal to the input parameter **prop\_name**.

EXPRESS specification:

```

*)
FUNCTION verify_required_resource_property (
    crd:          characterized_resource_definition;
    prop_name:    STRING
): LOGICAL;

    RETURN (1 = SIZEOF (get_resource_property (crd, prop_name)));
END_FUNCTION;
(*

```

Argument definitions:

**crd:** the **characterized\_resource\_definition** that appears as the **definition** of the **resource\_property** instances to examine.

**prop\_name:** the string that appears as the **name** of the **resource\_property** instances to examine.

### 5.2.5.50 verify\_required\_tool\_body\_item

The **verify\_required\_tool\_body\_item** function examines the **representation\_item** instances that have a **name** equal to the input parameter **prop\_name** and are associated with the input **machining\_tool** through a **resource\_property** with a **name** of 'tool body' and a **representation** of type

**machining\_tool\_body\_representation.** The function returns true if and only if there is at most one such **representation\_item** instance.

EXPRESS specification:

```
*)
FUNCTION verify_required_tool_body_item (
    mt :          machining_tool;
    prop_name : STRING
): LOGICAL;

    RETURN (1 = SIZEOF (get_tool_body_item (mt, prop_name)));
END_FUNCTION;
(*
```

Argument definitions:

**mt:** the **machining\_tool** that is related through a **resource\_property** to the **representation\_item** instances to examine.

**prop\_name:** the string that appears as the **name** of the **representation\_item** instances to examine.

### 5.2.5.51 verify\_rotary\_speed\_measure\_rep\_item

The **verify\_rotary\_speed\_measure\_rep\_item** function returns true if and only if the **items** set of the input **representation** contains a **representation\_item** with a **name** equal to the input parameter **prop\_name** that is of type **measure\_representation\_item** and has a **value\_component** of type **numeric\_measure**.

EXPRESS specification:

```
*)
FUNCTION verify_rotary_speed_measure_rep_item (
    rep:          representation;
    prop_name:    STRING
): LOGICAL;

    RETURN (0 = SIZEOF (QUERY ( it <* rep.items |
        (it.name = prop_name) AND NOT
        (('INTEGRATED_CNC_SCHEMA.MEASURE_REPRESENTATION_ITEM'
         IN TYPEOF(it)) AND
         ('INTEGRATED_CNC_SCHEMA.NUMERIC_MEASURE'
         IN TYPEOF(it.value_component))))));
END_FUNCTION;
(*
```

Argument definitions:

**rep:** the **representation** to examine.

**prop\_name:** the string that appears as the **name** of the **representation\_item** instances to examine.

### 5.2.5.52 verify\_time\_measure\_action\_property

The **verify\_time\_measure\_action\_property** function evaluates each **action\_property** that refers to the input **characterized\_action\_definition** and has a **name** equal to the input parameter **prop\_name**. The function returns true if and only if all such **action\_properties** have an associated **representation** in which the **items** set contains a **representation\_item** that is of type **measure\_representation\_item** and **time\_measure\_with\_unit**.

#### EXPRESS specification:

```
*)
FUNCTION verify_time_measure_action_property (
    cad:          characterized_action_definition;
    prop_name:    STRING
): LOGICAL;

    RETURN (verify_rep_item_for_action_property(cad, prop_name,
        ['INTEGRATED_CNC_SCHEMA.MEASURE_REPRESENTATION_ITEM',
         'INTEGRATED_CNC_SCHEMA.TIME_MEASURE_WITH_UNIT']));
END_FUNCTION;
(*
```

#### Argument definitions:

**cad:** the **characterized\_action\_definition** that appears as the **definition** of the **action\_property** instances to examine.

**prop\_name:** the string that appears as the **name** of the **action\_property** instances to examine.

### 5.2.5.53 verify\_time\_measure\_rep\_item

The **verify\_time\_measure\_rep\_item** function returns true if and only if the **items** set of the input **representation** contains a **representation\_item** with a **name** equal to the input parameter **prop\_name** that is of type **measure\_representation\_item** and **ratio\_measure\_with\_unit**.

#### EXPRESS specification:

```
*)
FUNCTION verify_time_measure_rep_item (
    rep:          representation;
    prop_name:    STRING
): LOGICAL;

    RETURN (0 = SIZEOF (QUERY ( it <* rep.items |
        (it.name = prop_name) AND NOT (SIZEOF([
            'INTEGRATED_CNC_SCHEMA.MEASURE_REPRESENTATION_ITEM',
            'INTEGRATED_CNC_SCHEMA.TIME_MEASURE_WITH_UNIT'] *
            TYPEOF(it)) = 2))));
END_FUNCTION;
(*
```

Argument definitions:

**rep:** the **representation** to examine.

**prop\_name:** the string that appears as the **name** of the **representation\_item** instances to examine.

**5.2.5.54 verify\_time\_measure\_resource\_property**

The **verify\_time\_measure\_resource\_property** function evaluates each **resource\_property** that refers to the input **characterized\_resource\_definition** and has a **name** equal to the input parameter **prop\_name**. The function returns true if and only if all such **resource\_properties** have an associated **representation** in which the **items** set contains a **representation\_item** that is of type **measure\_representation\_item** and **time\_measure\_with\_unit**.

EXPRESS specification:

```
*)
FUNCTION verify_time_measure_resource_property (
    crd:          characterized_resource_definition;
    prop_name:    STRING
): LOGICAL;

    RETURN (verify_rep_item_for_resource_property (crd, prop_name,
        ['INTEGRATED_CNC_SCHEMA.MEASURE_REPRESENTATION_ITEM',
         'INTEGRATED_CNC_SCHEMA.TIME_MEASURE_WITH_UNIT']));
END_FUNCTION;
(*
```

Argument definitions:

**crd:** the **characterized\_resource\_definition** that appears as the **definition** of the **resource\_property** instances to examine.

**prop\_name:** the string that appears as the **name** of the **resource\_property** instances to examine.

```
*)
END_SCHEMA;
(*
```

[Blank page]

## 6 Conformance requirements

Conformance to this part of ISO 10303 includes satisfying the requirements stated in this part, the requirements of the implementation method(s) supported, and the relevant requirements of the normative references.

An implementation shall support at least one of the following implementation methods:

- ISO 10303-21.

Requirements with respect to implementation methods-specific requirements are specified in Annex C.

The Protocol Implementation Conformance Statement (PICS) proforma lists the options or the combinations of options that may be included in the implementation. The PICS proforma is provided in Annex D.

This part of ISO 10303 provides for a number of options that may be supported by an implementation. These options have been grouped into the following conformance classes:

- Tool path programming (CC1);
- Closed-loop programming (CC2);
- Feature-based programming (CC3);
- Generative programming (CC4).

These conformance classes are defined so that each class includes all the options specified by the preceding class. Support for a particular conformance class requires support of all the options specified in that class.

**EXAMPLE** CC2 contains everything in CC1, plus additional options. CC3 contains everything in CC2, plus additional options. CC4 contains everything in CC3, plus all remaining options.

Conformance to a particular class requires that all AIM elements defined as part of that class be supported. Table 15 defines the classes to which each AIM element belongs. The conformance classes are described in detail by the following sections.

Annotated example data sets for several conformance classes are provided in Annex J.

### 6.1 Conformance Class for tool path programming (CC1)

This conformance class supports the description of machining programs containing a single sequence of operations, each of which is described using the machine-independent path of the tool centre point, using a simplified set of curves types, as well as tool requirements, management information about the program, and all technology-specific process parameters.

This conformance class includes all application objects from the measure, operation, project, workpiece, process data for milling, cutting tools for milling, process data for turning, cutting tools for turning, library reference, and management UoFs.

NOTE Since this conformance class requires a toolpath for every operation, any specified strategy is simply for additional information. In the absence of any other useful information, it is recommended that the machining operation be specified as a `Freeform_operation` with no associated strategies.

This conformance class includes the following application objects and their supertypes from the executable UoF:

- `Machining_tool`;
- `Machining_workingstep`;
- `NC_function`, the subtypes `Display_message`, `NC_legacy_function`, `Optional_stop`, `Program_stop`, `Set_mark`, `Wait_for_mark`, and the supporting object `Channel`;
- `Rapid_movement` and the subtype `Return_home`;
- `Setup` and the supporting objects `Workpiece_setup` and `Setup_instruction`;
- `Workplan`.

This conformance class includes the following application objects and their supertypes from the toolpath UoF:

- `Cutter_location_trajectory`;
- `Feedstop`;
- `Toolpath_speed`.

In addition, the following apply to use of the application objects in this conformance class:

- the `its_toolpath` shall be specified for each `Operation` object;
- the `its_feature` need not be specified for a particular `Machining_workingstep` object;
- the `its_secplane` need not be specified for a particular `Machining_workingstep` object;
- the dataset shall contain exactly one `Workplan` object;
- no geometric shape information shall be specified for `Machining_workingstep` `its_effect`, `Manufacturing_feature` `explicit_representation`, `Workpiece` `its_geometry` or `its_bounding_geometry`, `Workpiece_setup` `its_restricted_area`, or `Workplan` `its_effect`.



## 6.2 Conformance Class for closed-loop programming (CC2)

This conformance class extends the previous conformance class to support the description of machining programs with the full range of toolpath specifications as well as full shape information for the workpiece, rawpiece and restricted areas on the setup.

This conformance class includes everything specified by CC1, plus all remaining application objects from the toolpath UoF and the Parallel application object from the executable UOF.

In addition, the following apply to use of the application objects in this conformance class:

- the dataset may contain multiple, nested Workplan objects;
- the `basiccurve`, `its_toolaxis`, and `surface_normal` for each `Cutter_location_trajectory` object may be described by any `bounded_curve` type;
- geometric shape information may be specified for `Machining_workingstep` `its_effect`, `Workpiece` `its_geometry` or `its_bounding_geometry`, `Workpiece_setup` `its_restricted_area`, or `Workplan` `its_effect`.

## 6.3 Conformance Class for feature-based programming (CC3)

This conformance class extends the previous conformance class to support the description of machining programs using the full range of executable constructs and manufacturing process features defined by implicit parameters.

This conformance class includes everything specified by CC2, plus all application objects from the manufacturing feature and manufacturing feature for turning UOFs and all remaining application objects from the executable UoF.

In addition, the following apply to use of the application objects in this conformance class:

- the `its_toolpath` need not be specified for a particular `Operation` object;
- the `its_feature` shall be specified for all `Machining_workingstep` objects;
- the `its_secplane` shall be specified for all `Machining_workingstep` objects.

## 6.4 Conformance Class for generative programming (CC4)

This conformance class extends the previous conformance class to support the description of geometric dimension and tolerance information sufficient to compute optimal speeds and feeds, manufacturing features appearing on the final product shape, and features with linkage to explicit geometry.

This conformance class includes everything specified by CC3, plus all application objects from the geometric dimensioning and tolerancing UOF and all remaining application objects from other UoFs.

In addition, the following apply to use of the application objects in this conformance class:

- the final\_features may be specified for any Machining\_workingstep object;
- the explicit\_representation may be specified for any Manufacturing\_feature object.

**Table 16 — Conformance class elements**

AIM element	Conformance class			
	1	2	3	4
action	X	X	X	X
action_method	X	X	X	X
action_method_relationship	X	X	X	X
action_method_with_associated_documents	X	X	X	X
action_property	X	X	X	X
action_property_representation	X	X	X	X
action_relationship			X	X
action_resource	X	X	X	X
action_resource_relationship	X	X	X	X
action_resource_requirement	X	X	X	X
action_resource_requirement_relationship	X	X	X	X
action_resource_type	X	X	X	X
address	X	X	X	X
advanced_brep_shape_representation		X	X	X
advanced_face		X	X	X
and_expression			X	X
angular_location			X	X
angular_size			X	X
angularity_tolerance			X	X
apex				X
application_context	X	X	X	X
application_context_element	X	X	X	X
application_protocol_definition	X	X	X	X
applied_approval_assignment	X	X	X	X
applied_area			X	X
applied_classification_assignment	X	X	X	X

**Table 16 — Conformance class elements (continued)**

AIM element	Conformance class			
	1	2	3	4
applied_date_and_time_assignment	X	X	X	X
applied_date_assignment	X	X	X	X
applied_document_reference	X	X	X	X
applied_document_usage_constraint_assignment	X	X	X	X
applied_external_identification_assignment	X	X	X	X
applied_identification_assignment				X
applied_organization_assignment	X	X	X	X
applied_person_and_organization_assignment	X	X	X	X
applied_security_classification_assignment	X	X	X	X
approval	X	X	X	X
approval_assignment	X	X	X	X
approval_date_time	X	X	X	X
approval_person_organization	X	X	X	X
approval_relationship	X	X	X	X
approval_role	X	X	X	X
approval_status	X	X	X	X
assembly_component_usage	X	X	X	X
axis1_placement	X	X	X	X
axis2_placement_2d	X	X	X	X
axis2_placement_3d	X	X	X	X
b_spline_curve	X	X	X	X
b_spline_curve_with_knots	X	X	X	X
b_spline_surface		X	X	X
b_spline_surface_with_knots		X	X	X
back_boring_operation	X	X	X	X
bezier_curve	X	X	X	X
bezier_surface		X	X	X
binary_boolean_expression			X	X
binary_generic_expression			X	X
block		X	X	X

**Table 16 — Conformance class elements (continued)**

AIM element	Conformance class			
	1	2	3	4
block_shape_representation		X	X	X
boolean_expression			X	X
boring_operation	X	X	X	X
boss			X	X
boss_top			X	X
bottom_and_side_milling_operation	X	X	X	X
boundary_curve	X	X	X	X
bounded_curve	X	X	X	X
bounded_pcurve		X	X	X
bounded_surface		X	X	X
bounded_surface_curve	X	X	X	X
brep_with_voids		X	X	X
calendar_date	X	X	X	X
cartesian_point	X	X	X	X
cartesian_transformation_operator	X	X	X	X
cartesian_transformation_operator_3d	X	X	X	X
centre_of_symmetry				X
chamfer			X	X
chamfer_offset			X	X
characterized_object	X	X	X	X
circle	X	X	X	X
circular_closed_profile			X	X
circular_pattern			X	X
circular_runout_tolerance				X
class	X	X	X	X
classification_assignment	X	X	X	X
classification_role	X	X	X	X
closed_path_profile			X	X
closed_shell		X	X	X
coaxiality_tolerance				X

**Table 16 — Conformance class elements (continued)**

AIM element	Conformance class			
	1	2	3	4
common_datum				X
comparison_equal			X	X
comparison_expression			X	X
comparison_greater			X	X
comparison_greater_equal			X	X
comparison_less			X	X
comparison_less_equal			X	X
comparison_not_equal			X	X
composite_curve	X	X	X	X
composite_curve_on_surface	X	X	X	X
composite_curve_segment	X	X	X	X
composite_hole			X	X
composite_shape_aspect			X	X
compound_feature			X	X
compound_representation_item			X	X
concentricity_tolerance				X
concurrent_action_method		X	X	X
conic	X	X	X	X
conical_surface		X	X	X
connected_edge_set		X	X	X
connected_face_set		X	X	X
context_dependent_shape_representation	X	X	X	X
context_dependent_unit	X	X	X	X
contouring_turning_operation	X	X	X	X
conversion_based_unit	X	X	X	X
coordinated_universal_time_offset	X	X	X	X
curve	X	X	X	X
curve_bounded_surface		X	X	X
curve_replica		X	X	X
cylindrical_shape_representation		X	X	X

**Table 16 — Conformance class elements (continued)**

AIM element	Conformance class			
	1	2	3	4
cylindrical_surface		X	X	X
cylindricity_tolerance				X
data_environment			X	X
date	X	X	X	X
date_and_time	X	X	X	X
date_and_time_assignment	X	X	X	X
date_assignment	X	X	X	X
date_role	X	X	X	X
date_time_role	X	X	X	X
datum				X
datum_feature				X
datum_reference				X
datum_target				X
definitional_representation		X	X	X
degenerate_pcurve		X	X	X
degenerate_toroidal_surface		X	X	X
derived_shape_aspect			X	X
derived_unit	X	X	X	X
derived_unit_element	X	X	X	X
description_attribute	X	X	X	X
descriptive_representation_item	X	X	X	X
dimension_related_tolerance_zone_element				X
dimensional_characteristic_representation				X
dimensional_exponents	X	X	X	X
dimensional_location				X
dimensional_location_with_path				X
dimensional_size				X
dimensional_size_with_path				X
directed_dimensional_location				X
direction	X	X	X	X

**Table 16 — Conformance class elements (continued)**

AIM element	Conformance class			
	1	2	3	4
direction_shape_representation			X	X
document	X	X	X	X
document_file	X	X	X	X
document_reference	X	X	X	X
document_representation_type	X	X	X	X
document_type	X	X	X	X
document_usage_constraint	X	X	X	X
document_usage_constraint_assignment	X	X	X	X
document_usage_role	X	X	X	X
document_with_class	X	X	X	X
drilling_operation	X	X	X	X
drilling_type_operation	X	X	X	X
drilling_type_strategy	X	X	X	X
edge		X	X	X
edge_based_wireframe_model		X	X	X
edge_based_wireframe_shape_representation		X	X	X
edge_curve		X	X	X
edge_loop		X	X	X
edge_round			X	X
elementary_surface	X	X	X	X
ellipse	X	X	X	X
environment			X	X
evaluated_degenerate_pcurve		X	X	X
expanded_uncertainty			X	X
expression			X	X
expression_representation_item			X	X
extension				X
external_identification_assignment	X	X	X	X
external_source			X	X
externally_defined_class	X	X	X	X

**Table 16 — Conformance class elements (continued)**

AIM element	Conformance class			
	1	2	3	4
externally_defined_dimension_definition				X
externally_defined_feature_definition			X	X
externally_defined_general_property	X	X	X	X
externally_defined_item			X	X
externally_defined_item_relationship	X	X	X	X
externally_defined_representation_with_parameters	X	X	X	X
face		X	X	X
face_based_surface_model		X	X	X
face_bound		X	X	X
face_outer_bound		X	X	X
face_shape_representation			X	X
face_surface		X	X	X
faceted_brep		X	X	X
faceted_brep_shape_representation		X	X	X
facing_turning_operation	X	X	X	X
feature_component_definition			X	X
feature_component_relationship			X	X
feature_definition			X	X
feature_pattern			X	X
fillet			X	X
flat_face			X	X
flatness_tolerance				X
founded_item	X	X	X	X
freeform_milling_operation	X	X	X	X
freeform_milling_strategy	X	X	X	X
freeform_milling_tolerance_representation	X	X	X	X
functionally_defined_transformation			X	X
gear			X	X
general_property	X	X	X	X
general_property_association	X	X	X	X



**Table 16 — Conformance class elements (continued)**

AIM element	Conformance class			
	1	2	3	4
generic_expression			X	X
generic_literal			X	X
generic_variable			X	X
geometric_alignment				X
geometric_curve_set		X	X	X
geometric_intersection				X
geometric_representation_context	X	X	X	X
geometric_representation_item	X	X	X	X
geometric_set		X	X	X
geometric_tolerance				X
geometric_tolerance_relationship				X
geometric_tolerance_with_datum_reference				X
geometric_tolerance_with_defined_unit				X
geometrically_bounded_surface_shape_representation		X	X	X
geometrically_bounded_wireframe_shape_representation		X	X	X
global_uncertainty_assigned_context	X	X	X	X
global_unit_assigned_context	X	X	X	X
grooving_turning_operation	X	X	X	X
group	X	X	X	X
hole_bottom			X	X
hyperbola	X	X	X	X
id_attribute	X	X	X	X
identification_assignment				X
identification_role				X
instanced_feature			X	X
int_literal			X	X
int_numeric_variable			X	X
intersection_curve			X	X
item_defined_transformation	X	X	X	X
known_source	X	X	X	X

**Table 16 — Conformance class elements (continued)**

AIM element	Conformance class			
	1	2	3	4
knurling_turning_operation	X	X	X	X
length_measure_with_unit	X	X	X	X
length_unit	X	X	X	X
limits_and_fits				X
line	X	X	X	X
line_profile_tolerance				X
linear_profile			X	X
literal_number			X	X
local_time	X	X	X	X
location_shape_representation			X	X
loop		X	X	X
machining_adaptive_control_relationship	X	X	X	X
machining_approach_retract_strategy	X	X	X	X
machining_cutting_component	X	X	X	X
machining_cutting_corner_representation	X	X	X	X
machining_dwell_time_representation	X	X	X	X
machining_execution_resource	X	X	X	X
machining_feature_process			X	X
machining_feature_relationship			X	X
machining_feature_sequence_relationship			X	X
machining_feed_speed_representation	X	X	X	X
machining_final_feature_relationship				X
machining_functions	X	X	X	X
machining_functions_relationship	X	X	X	X
machining_nc_function	X	X	X	X
machining_offset_vector_representation			X	X
machining_operation	X	X	X	X
machining_operation_relationship	X	X	X	X
machining_operator_instruction	X	X	X	X
machining_operator_instruction_relationship	X	X	X	X

**Table 16 — Conformance class elements (continued)**

AIM element	Conformance class			
	1	2	3	4
machining_process_body_relationship	X	X	X	X
machining_process_branch_relationship			X	X
machining_process_concurrent_relationship		X	X	X
machining_process_executable	X	X	X	X
machining_process_model	X	X	X	X
machining_process_model_relationship	X	X	X	X
machining_process_sequence_relationship	X	X	X	X
machining_project	X	X	X	X
machining_project_workpiece_relationship	X	X	X	X
machining_rapid_movement	X	X	X	X
machining_setup	X	X	X	X
machining_setup_workpiece_relationship	X	X	X	X
machining_spindle_speed_representation	X	X	X	X
machining_strategy	X	X	X	X
machining_strategy_relationship	X	X	X	X
machining_technology	X	X	X	X
machining_technology_relationship	X	X	X	X
machining_tool	X	X	X	X
machining_tool_body_representation	X	X	X	X
machining_tool_direction_representation	X	X	X	X
machining_tool_usage	X	X	X	X
machining_toolpath	X	X	X	X
machining_toolpath_sequence_relationship	X	X	X	X
machining_toolpath_speed_profile_representation	X	X	X	X
machining_touch_probing			X	X
machining_workingstep	X	X	X	X
machining_workplan	X	X	X	X
make_from_usage_option	X	X	X	X
manifold_solid_brep		X	X	X
manifold_surface_shape_representation			X	X

**Table 16 — Conformance class elements (continued)**

AIM element	Conformance class			
	1	2	3	4
mapped_item		X	X	X
marking			X	X
mass_measure_with_unit	X	X	X	X
mass_unit	X	X	X	X
material_designation	X	X	X	X
material_designation_characterization	X	X	X	X
material_property	X	X	X	X
material_property_representation	X	X	X	X
measure_qualification			X	X
measure_representation_item	X	X	X	X
measure_with_unit	X	X	X	X
milling_type_operation	X	X	X	X
milling_type_strategy	X	X	X	X
modified_geometric_tolerance				X
modified_pattern			X	X
multiple_arity_boolean_expression			X	X
multiple_arity_generic_expression			X	X
name_attribute	X	X	X	X
named_unit	X	X	X	X
next_assembly_usage_occurrence	X	X	X	X
ngon_closed_profile			X	X
ngon_shape_representation			X	X
non_manifold_surface_shape_representation		X	X	X
not_expression			X	X
numeric_expression			X	X
numeric_variable			X	X
object_role	X	X	X	X
offset_curve_3d		X	X	X
offset_surface		X	X	X
open_path_profile			X	X

**Table 16 — Conformance class elements (continued)**

AIM element	Conformance class			
	1	2	3	4
open_shell		X	X	X
or_expression			X	X
ordinal_date	X	X	X	X
organization	X	X	X	X
organization_assignment	X	X	X	X
organization_role	X	X	X	X
organizational_address	X	X	X	X
oriented_closed_shell		X	X	X
oriented_edge		X	X	X
oriented_face		X	X	X
oriented_open_shell		X	X	X
oriented_path		X	X	X
outer_boundary_curve	X	X	X	X
outer_round			X	X
outside_profile			X	X
parabola	X	X	X	X
parallel_offset				X
parallelism_tolerance				X
parametric_representation_context		X	X	X
partial_circular_profile			X	X
path		X	X	X
path_feature_component			X	X
path_shape_representation			X	X
pattern_offset_membership			X	X
pattern_omit_membership			X	X
pcurve		X	X	X
perpendicular_to				X
perpendicularity_tolerance				X
person	X	X	X	X
person_and_organization	X	X	X	X

**Table 16 — Conformance class elements (continued)**

AIM element	Conformance class			
	1	2	3	4
person_and_organization_assignment	X	X	X	X
person_and_organization_role	X	X	X	X
personal_address	X	X	X	X
placed_datum_target_feature				X
placement	X	X	X	X
planar_shape_representation			X	X
plane	X	X	X	X
plane_angle_measure_with_unit	X	X	X	X
plane_angle_unit	X	X	X	X
plane_milling_operation	X	X	X	X
plus_minus_tolerance				X
pocket			X	X
pocket_bottom			X	X
point	X	X	X	X
point_on_curve		X	X	X
point_on_surface		X	X	X
point_replica		X	X	X
poly_loop		X	X	X
polyline	X	X	X	X
position_tolerance				X
pre_defined_item	X	X	X	X
precision_qualifier	X	X	X	X
process_product_association	X	X	X	X
process_property_association			X	X
product	X	X	X	X
product_category			X	X
product_category_relationship			X	X
product_context	X	X	X	X
product_definition	X	X	X	X
product_definition_context	X	X	X	X

**Table 16 — Conformance class elements (continued)**

AIM element	Conformance class			
	1	2	3	4
product_definition_formation	X	X	X	X
product_definition_formation_with_specified_source	X	X	X	X
product_definition_process	X	X	X	X
product_definition_relationship	X	X	X	X
product_definition_shape		X	X	X
product_definition_usage	X	X	X	X
product_definition_with_associated_documents	X	X	X	X
product_related_product_category			X	X
profile_floor			X	X
projected_zone_definition				X
property_definition	X	X	X	X
property_definition_representation	X	X	X	X
property_process			X	X
protrusion				X
qualified_representation_item	X	X	X	X
qualitative_uncertainty	X	X	X	X
quasi_uniform_curve	X	X	X	X
quasi_uniform_surface		X	X	X
ratio_measure_with_unit	X	X	X	X
ratio_unit	X	X	X	X
rational_b_spline_curve	X	X	X	X
rational_b_spline_surface		X	X	X
real_literal			X	X
real_numeric_variable			X	X
rectangular_closed_profile			X	X
rectangular_composite_surface		X	X	X
rectangular_pattern			X	X
rectangular_trimmed_surface		X	X	X
referenced_modified_datum				X
removal_volume			X	X

**Table 16 — Conformance class elements (continued)**

AIM element	Conformance class			
	1	2	3	4
reparametrised_composite_curve_segment	X	X	X	X
replicate_feature			X	X
representation	X	X	X	X
representation_context	X	X	X	X
representation_item	X	X	X	X
representation_item_relationship	X	X	X	X
representation_map	X	X	X	X
representation_relationship	X	X	X	X
representation_relationship_with_transformation	X	X	X	X
requirement_for_action_resource	X	X	X	X
resource_property	X	X	X	X
resource_property_representation	X	X	X	X
resource_requirement_type	X	X	X	X
revolved_profile			X	X
rib_top			X	X
rib_top_floor			X	X
right_circular_cylinder		X	X	X
role_association	X	X	X	X
round_hole			X	X
rounded_end			X	X
rounded_u_profile			X	X
roundness_tolerance				X
runout_zone_definition				X
runout_zone_orientation				X
runout_zone_orientation_reference_direction				X
seam_curve		X	X	X
security_classification	X	X	X	X
security_classification_assignment	X	X	X	X
security_classification_level	X	X	X	X
sequential_method	X	X	X	X



**Table 16 — Conformance class elements (continued)**

AIM element	Conformance class			
	1	2	3	4
serial_action_method	X	X	X	X
shape_aspect			X	X
shape_aspect_deriving_relationship			X	X
shape_aspect_relationship			X	X
shape_defining_relationship			X	X
shape_definition_representation		X	X	X
shape_dimension_representation				X
shape_representation		X	X	X
shape_representation_relationship		X	X	X
shape_representation_with_parameters			X	X
shell_based_surface_model		X	X	X
shell_based_wireframe_model		X	X	X
shell_based_wireframe_shape_representation		X	X	X
si_unit	X	X	X	X
side_milling_operation	X	X	X	X
simple_generic_expression			X	X
simple_numeric_expression			X	X
slot			X	X
slot_end			X	X
solid_angle_measure_with_unit	X	X	X	X
solid_angle_unit	X	X	X	X
solid_model		X	X	X
spherical_cap			X	X
spherical_surface		X	X	X
square_u_profile			X	X
standard_uncertainty	X	X	X	X
step			X	X
straightness_tolerance				X
surface		X	X	X
surface_curve		X	X	X

**Table 16 — Conformance class elements (continued)**

AIM element	Conformance class			
	1	2	3	4
surface_of_linear_extrusion		X	X	X
surface_of_revolution	X	X	X	X
surface_patch		X	X	X
surface_profile_tolerance				X
surface_replica		X	X	X
surface_texture_representation	X	X	X	X
swept_surface		X	X	X
symmetric_shape_aspect				X
symmetry_tolerance				X
tangent				X
taper			X	X
tapping_operation	X	X	X	X
tee_profile			X	X
thread			X	X
thread_runout			X	X
threading_turning_operation	X	X	X	X
time_measure_with_unit	X	X	X	X
time_unit	X	X	X	X
tolerance_value				X
tolerance_zone				X
tolerance_zone_definition				X
tolerance_zone_form				X
topological_representation_item		X	X	X
toroidal_surface		X	X	X
total_runout_tolerance				X
transition_feature			X	X
trimmed_curve	X	X	X	X
turned_knurl			X	X
turning_type_operation	X	X	X	X
turning_type_strategy	X	X	X	X

**Table 16 — Conformance class elements (continued)**

AIM element	Conformance class			
	1	2	3	4
type_qualifier	X	X	X	X
unary_boolean_expression			X	X
unary_generic_expression			X	X
uncertainty_measure_with_unit			X	X
uncertainty_qualifier			X	X
uniform_curve	X	X	X	X
uniform_surface		X	X	X
value_range	X	X	X	X
value_representation_item	X	X	X	X
variable			X	X
variable_semantics			X	X
vector	X	X	X	X
vee_profile			X	X
vertex		X	X	X
vertex_loop		X	X	X
vertex_point		X	X	X
vertex_shell		X	X	X
week_of_year_and_day_date	X	X	X	X
wire_shell		X	X	X
xor_expression			X	X

## Annex A (normative)

### AIM EXPRESS expanded listing

The following EXPRESS is the expanded form of the short form schema given in 5.2. In the event of any discrepancy between the short form and this expanded listing, the expanded listing shall be used.

```

SCHEMA integrated_cnc_schema;

CONSTANT
    dummy_gri : geometric_representation_item := representation_item(') ||
                geometric_representation_item();
    dummy_tri : topological_representation_item := representation_item(')
                || topological_representation_item();
END_CONSTANT;

TYPE ahead_or_behind = ENUMERATION OF
    (ahead,
     exact,
     behind);
END_TYPE; -- 10303-41: date_time_schema

TYPE angle_relator = ENUMERATION OF
    (equal,
     large,
     small);
END_TYPE; -- 10303-47: shape_dimension_schema

TYPE approval_item = SELECT
    (product,
     product_definition,
     product_definition_formation,
     security_classification);
END_TYPE; -- 10303-238: integrated_cnc_schema

TYPE area_measure = REAL;
END_TYPE; -- 10303-41: measure_schema

TYPE axis2_placement = SELECT
    (axis2_placement_2d,
     axis2_placement_3d);
END_TYPE; -- 10303-42: geometry_schema

TYPE b_spline_curve_form = ENUMERATION OF
    (polyline_form,
     circular_arc,
     elliptic_arc,
     parabolic_arc,
     hyperbolic_arc,

```

```

    unspecified);
END_TYPE; -- 10303-42: geometry_schema

TYPE b_spline_surface_form = ENUMERATION OF
(plane_surf,
 cylindrical_surf,
 conical_surf,
 spherical_surf,
 toroidal_surf,
 surf_of_revolution,
 ruled_surf,
 generalised_cone,
 quadric_surf,
 surf_of_linear_extrusion,
 unspecified);
END_TYPE; -- 10303-42: geometry_schema

TYPE characterized_action_definition = SELECT
(action,
 action_method,
 action_method_relationship,
 action_relationship);
END_TYPE; -- 10303-49: process_property_schema

TYPE characterized_definition = SELECT
(characterized_object,
 characterized_product_definition,
 shape_definition);
END_TYPE; -- 10303-41: product_property_definition_schema

TYPE characterized_material_property = SELECT
(material_property_representation);
END_TYPE; -- 10303-45: material_property_definition_schema

TYPE characterized_product_definition = SELECT
(product_definition,
 product_definition_relationship);
END_TYPE; -- 10303-41: product_property_definition_schema

TYPE characterized_resource_definition = SELECT
(action_resource,
 action_resource_relationship,
 action_resource_requirement,
 action_resource_requirement_relationship);
END_TYPE; -- 10303-49: process_property_schema

TYPE classification_item = SELECT
(externally_defined_representation_with_parameters);
END_TYPE; -- 10303-238: integrated_cnc_schema

TYPE compound_item_definition = SELECT
(list_representation_item,
 set_representation_item);
END_TYPE; -- 10303-43: representation_schema

```

## ISO 10303-238:2007(E)

```
TYPE context_dependent_measure = REAL;
END_TYPE; -- 10303-41: measure_schema

TYPE count_measure = NUMBER;
END_TYPE; -- 10303-41: measure_schema

TYPE curve_on_surface = SELECT
  (pcurve,
   surface_curve,
   composite_curve_on_surface);
END_TYPE; -- 10303-42: geometry_schema

TYPE date_and_time_item = SELECT
  (approval_person_organization,
   machining_operation,
   machining_process_executable,
   machining_toolpath,
   product,
   product_definition,
   product_definition_formation,
   security_classification);
END_TYPE; -- 10303-238: integrated_cnc_schema

TYPE date_item = SELECT
  (product,
   product_definition,
   product_definition_formation);
END_TYPE; -- 10303-238: integrated_cnc_schema

TYPE date_time_select = SELECT
  (date,
   local_time,
   date_and_time);
END_TYPE; -- 10303-41: date_time_schema

TYPE day_in_month_number = INTEGER;
WHERE
  WR1: (1 <= SELF) AND (SELF <= 31);
END_TYPE; -- 10303-41: date_time_schema

TYPE day_in_week_number = INTEGER;
WHERE
  WR1: (1 <= SELF) AND (SELF <= 7);
END_TYPE; -- 10303-41: date_time_schema

TYPE day_in_year_number = INTEGER;
WHERE
  WR1: (1 <= SELF) AND (SELF <= 366);
END_TYPE; -- 10303-41: date_time_schema

TYPE derived_property_select = SELECT
  (property_definition,
   action_property,
```

```

    resource_property);
END_TYPE; -- 10303-41: product_property_definition_schema

```

```

TYPE description_attribute_select = SELECT
  (application_context,
   approval_role,
   date_role,
   date_time_role,
   context_dependent_shape_representation,
   external_source,
   organization_role,
   person_and_organization_role,
   person_and_organization,
   property_definition_representation,
   representation);
END_TYPE; -- 10303-41: basic_attribute_schema

```

```

TYPE descriptive_measure = STRING;
END_TYPE; -- 10303-41: measure_schema

```

```

TYPE dimension_count = INTEGER;
  WHERE
    WR1: SELF > 0;
END_TYPE; -- 10303-42: geometry_schema

```

```

TYPE dimensional_characteristic = SELECT
  (dimensional_location,
   dimensional_size);
END_TYPE; -- 10303-47: shape_dimension_schema

```

```

TYPE document_reference_item = SELECT
  (externally_defined_dimension_definition,
   externally_defined_feature_definition,
   material_designation,
   property_definition);
END_TYPE; -- 10303-238: integrated_cnc_schema

```

```

TYPE external_identification_item = SELECT
  (externally_defined_class,
   externally_defined_general_property);
END_TYPE; -- 10303-238: integrated_cnc_schema

```

```

TYPE founded_item_select = SELECT
  (founded_item,
   representation_item);
END_TYPE; -- 10303-43: representation_schema

```

```

TYPE geometric_set_select = SELECT
  (point,
   curve,
   surface);
END_TYPE; -- 10303-42: geometric_model_schema

```

```

TYPE hour_in_day = INTEGER;

```

## ISO 10303-238:2007(E)

WHERE

```
    WR1: (0 <= SELF) AND (SELF < 24);  
END_TYPE; -- 10303-41: date_time_schema
```

```
TYPE id_attribute_select = SELECT  
    (action,  
     address,  
     product_category,  
     property_definition,  
     shape_aspect,  
     shape_aspect_relationship,  
     application_context,  
     group,  
     representation);  
END_TYPE; -- 10303-41: basic_attribute_schema
```

```
TYPE identification_item = SELECT  
    (dimensional_size);  
END_TYPE; -- 10303-238: integrated_cnc_schema
```

```
TYPE identifier = STRING;  
END_TYPE; -- 10303-41: support_resource_schema
```

```
TYPE knot_type = ENUMERATION OF  
    (uniform_knots,  
     quasi_uniform_knots,  
     piecewise_bezier_knots,  
     unspecified);  
END_TYPE; -- 10303-42: geometry_schema
```

```
TYPE label = STRING;  
END_TYPE; -- 10303-41: support_resource_schema
```

```
TYPE length_measure = REAL;  
END_TYPE; -- 10303-41: measure_schema
```

```
TYPE limit_condition = ENUMERATION OF  
    (maximum_material_condition,  
     least_material_condition,  
     regardless_of_feature_size);  
END_TYPE; -- 10303-47: shape_aspect_definition_schema
```

```
TYPE list_of_reversible_topology_item = LIST [0:?] OF reversible_topology_item;  
END_TYPE; -- 10303-42: topology_schema
```

```
TYPE list_representation_item = LIST [1:?] OF representation_item;  
END_TYPE; -- 10303-43: representation_schema
```

```
TYPE mass_measure = REAL;  
END_TYPE; -- 10303-41: measure_schema
```

```
TYPE measure_value = SELECT  
    (length_measure,  
     mass_measure,
```



```

time_measure,
plane_angle_measure,
solid_angle_measure,
area_measure,
volume_measure,
ratio_measure,
parameter_value,
numeric_measure,
context_dependent_measure,
descriptive_measure,
positive_length_measure,
positive_plane_angle_measure,
count_measure);
END_TYPE; -- 10303-41: measure_schema

TYPE minute_in_hour = INTEGER;
WHERE
  WR1: (0 <= SELF) AND (SELF <= 59);
END_TYPE; -- 10303-41: date_time_schema

TYPE month_in_year_number = INTEGER;
WHERE
  WR1: (1 <= SELF) AND (SELF <= 12);
END_TYPE; -- 10303-41: date_time_schema

TYPE name_attribute_select = SELECT
(address,
context_dependent_shape_representation,
derived_unit,
person_and_organization,
product_definition,
property_definition_representation);
END_TYPE; -- 10303-41: basic_attribute_schema

TYPE numeric_measure = NUMBER;
END_TYPE; -- 10303-41: measure_schema

TYPE organization_item = SELECT
(product,
product_definition,
product_definition_formation,
known_source);
END_TYPE; -- 10303-238: integrated_cnc_schema

TYPE parameter_value = REAL;
END_TYPE; -- 10303-41: measure_schema

TYPE pcurve_or_surface = SELECT
(pcurve,
surface);
END_TYPE; -- 10303-42: geometry_schema

TYPE person_and_organization_item = SELECT
(product,

```

## ISO 10303-238:2007(E)

```
    product_definition,  
    product_definition_formation,  
    security_classification);  
END_TYPE; -- 10303-238: integrated_cnc_schema  
  
TYPE person_organization_select = SELECT  
    (person,  
     organization,  
     person_and_organization);  
END_TYPE; -- 10303-41: person_organization_schema  
  
TYPE plane_angle_measure = REAL;  
END_TYPE; -- 10303-41: measure_schema  
  
TYPE positive_length_measure = length_measure;  
    WHERE  
        WR1: SELF > 0.0;  
END_TYPE; -- 10303-41: measure_schema  
  
TYPE positive_plane_angle_measure = plane_angle_measure;  
    WHERE  
        WR1: SELF > 0.0;  
END_TYPE; -- 10303-41: measure_schema  
  
TYPE preferred_surface_curve_representation = ENUMERATION OF  
    (curve_3d,  
     pcurve_s1,  
     pcurve_s2);  
END_TYPE; -- 10303-42: geometry_schema  
  
TYPE property_or_shape_select = SELECT  
    (property_definition,  
     shape_definition);  
END_TYPE; -- 10303-49: process_property_schema  
  
TYPE ratio_measure = REAL;  
END_TYPE; -- 10303-41: measure_schema  
  
TYPE represented_definition = SELECT  
    (general_property,  
     property_definition,  
     shape_aspect,  
     shape_aspect_relationship);  
END_TYPE; -- 10303-41: product_property_representation_schema  
  
TYPE reversible_topology = SELECT  
    (reversible_topology_item,  
     list_of_reversible_topology_item,  
     set_of_reversible_topology_item);  
END_TYPE; -- 10303-42: topology_schema  
  
TYPE reversible_topology_item = SELECT  
    (edge,  
     path,
```

```

    face,
    face_bound,
    closed_shell,
    open_shell);
END_TYPE; -- 10303-42: topology_schema

TYPE role_select = SELECT
    (approval_assignment,
    approval_date_time,
    document_reference,
    security_classification_assignment);
END_TYPE; -- 10303-41: basic_attribute_schema

TYPE second_in_minute = REAL;
WHERE
    WR1: (0 <= SELF) AND (SELF <= 60.0);
END_TYPE; -- 10303-41: date_time_schema

TYPE security_classification_item = SELECT
    (machining_operation,
    machining_process_executable,
    machining_toolpath,
    product_definition,
    product_definition_formation);
END_TYPE; -- 10303-238: integrated_cnc_schema

TYPE set_of_reversible_topology_item = SET [0:?] OF reversible_topology_item;
END_TYPE; -- 10303-42: topology_schema

TYPE set_representation_item = SET [1:?] OF representation_item;
END_TYPE; -- 10303-43: representation_schema

TYPE shape_definition = SELECT
    (product_definition_shape,
    shape_aspect,
    shape_aspect_relationship);
END_TYPE; -- 10303-41: product_property_definition_schema

TYPE shell = SELECT
    (vertex_shell,
    wire_shell,
    open_shell,
    closed_shell);
END_TYPE; -- 10303-42: topology_schema

TYPE si_prefix = ENUMERATION OF
    (exa,
    peta,
    tera,
    giga,
    mega,
    kilo,
    hecto,
    deca,

```

ISO 10303-238:2007(E)

```
    deci,  
    centi,  
    milli,  
    micro,  
    nano,  
    pico,  
    femto,  
    atto);  
END_TYPE; -- 10303-41: measure_schema  
  
TYPE si_unit_name = ENUMERATION OF  
    (metre,  
    gram,  
    second,  
    ampere,  
    kelvin,  
    mole,  
    candela,  
    radian,  
    steradian,  
    hertz,  
    newton,  
    pascal,  
    joule,  
    watt,  
    coulomb,  
    volt,  
    farad,  
    ohm,  
    siemens,  
    weber,  
    tesla,  
    henry,  
    degree_celsius,  
    lumen,  
    lux,  
    becquerel,  
    gray,  
    sievert);  
END_TYPE; -- 10303-41: measure_schema  
  
TYPE solid_angle_measure = REAL;  
END_TYPE; -- 10303-41: measure_schema  
  
TYPE source = ENUMERATION OF  
    (made,  
    bought,  
    not_known);  
END_TYPE; -- 10303-41: product_definition_schema  
  
TYPE source_item = SELECT  
    (identifier);  
END_TYPE; -- 10303-41: external_reference_schema
```

```

TYPE supported_item = SELECT
  (action,
   action_method);
END_TYPE; -- 10303-41: action_schema

TYPE text = STRING;
END_TYPE; -- 10303-41: support_resource_schema

TYPE time_measure = REAL;
END_TYPE; -- 10303-41: measure_schema

TYPE tolerance_method_definition = SELECT
  (tolerance_value,
   limits_and_fits);
END_TYPE; -- 10303-47: shape_tolerance_schema

TYPE transformation = SELECT
  (item_defined_transformation,
   functionally_defined_transformation);
END_TYPE; -- 10303-43: representation_schema

TYPE transition_code = ENUMERATION OF
  (discontinuous,
   continuous,
   cont_same_gradient,
   cont_same_gradient_same_curvature);
END_TYPE; -- 10303-42: geometry_schema

TYPE trimming_preference = ENUMERATION OF
  (cartesian,
   parameter,
   unspecified);
END_TYPE; -- 10303-42: geometry_schema

TYPE trimming_select = SELECT
  (cartesian_point,
   parameter_value);
END_TYPE; -- 10303-42: geometry_schema

TYPE unit = SELECT
  (named_unit,
   derived_unit);
END_TYPE; -- 10303-41: measure_schema

TYPE value_qualifier = SELECT
  (precision_qualifier,
   type_qualifier,
   uncertainty_qualifier);
END_TYPE; -- 10303-45: qualified_measure_schema

TYPE vector_or_direction = SELECT
  (vector,
   direction);
END_TYPE; -- 10303-42: geometry_schema

```

## ISO 10303-238:2007(E)

```
TYPE volume_measure = REAL;
END_TYPE; -- 10303-41: measure_schema

TYPE week_in_year_number = INTEGER;
WHERE
  WR1: (1 <= SELF) AND (SELF <= 53);
END_TYPE; -- 10303-41: date_time_schema

TYPE wireframe_model = SELECT
  (shell_based_wireframe_model,
   edge_based_wireframe_model);
END_TYPE; -- 10303-42: geometric_model_schema

TYPE year_number = INTEGER;
END_TYPE; -- 10303-41: date_time_schema

ENTITY action;
  name          : label;
  description    : OPTIONAL text;
  chosen_method : action_method;
DERIVE
  id : identifier := get_id_value(SELF);
WHERE
  WR1: SIZEOF(USEDIN(SELF, 'INTEGRATED_CNC_SCHEMA.' +
                    'ID_ATTRIBUTE.IDENTIFIED_ITEM')) <= 1;
END_ENTITY; -- 10303-41: action_schema

ENTITY action_method;
  name          : label;
  description   : OPTIONAL text;
  consequence   : text;
  purpose       : text;
END_ENTITY; -- 10303-41: action_schema

ENTITY action_method_relationship;
  name          : label;
  description   : OPTIONAL text;
  relating_method : action_method;
  related_method  : action_method;
END_ENTITY; -- 10303-41: action_schema

ENTITY action_method_with_associated_documents
  SUBTYPE OF (action_method);
  documents : SET [1:?] OF document;
END_ENTITY; -- 10303-49: method_definition_schema

ENTITY action_property;
  name          : label;
  description   : text;
  definition    : characterized_action_definition;
END_ENTITY; -- 10303-49: process_property_schema

ENTITY action_property_representation;
```

```

    name          : label;
    description    : text;
    property       : action_property;
    representation : representation;
END_ENTITY; -- 10303-49: process_property_representation_schema

ENTITY action_relationship;
    name          : label;
    description    : OPTIONAL text;
    relating_action : action;
    related_action  : action;
END_ENTITY; -- 10303-41: action_schema

ENTITY action_resource;
    name          : label;
    description    : OPTIONAL text;
    usage         : SET [1:?] OF supported_item;
    kind          : action_resource_type;
END_ENTITY; -- 10303-41: action_schema

ENTITY action_resource_relationship;
    name          : label;
    description    : OPTIONAL text;
    relating_resource : action_resource;
    related_resource  : action_resource;
END_ENTITY; -- 10303-41: action_schema

ENTITY action_resource_requirement;
    name          : label;
    description    : text;
    kind          : resource_requirement_type;
    operations    : SET [1:?] OF characterized_action_definition;
END_ENTITY; -- 10303-49: process_property_schema

ENTITY action_resource_requirement_relationship;
    name          : label;
    description    : text;
    relating_action_resource_requirement : action_resource_requirement;
    related_action_resource_requirement  : action_resource_requirement;
    WHERE
        WR1: relating_action_resource_requirement :<>:
            related_action_resource_requirement;
END_ENTITY; -- 10303-49: process_property_schema

ENTITY action_resource_type;
    name : label;
END_ENTITY; -- 10303-41: action_schema

ENTITY address;
    internal_location    : OPTIONAL label;
    street_number        : OPTIONAL label;
    street               : OPTIONAL label;
    postal_box           : OPTIONAL label;
    town                 : OPTIONAL label;

```

```

    region                : OPTIONAL label;
    postal_code           : OPTIONAL label;
    country               : OPTIONAL label;
    facsimile_number      : OPTIONAL label;
    telephone_number      : OPTIONAL label;
    electronic_mail_address : OPTIONAL label;
    telex_number          : OPTIONAL label;
DERIVE
    name : label := get_name_value(SELF);
    url  : identifier := get_id_value(SELF);
WHERE
    WR1: (((((((((EXISTS(internal_location) OR EXISTS(street_number)) OR
        EXISTS(street)) OR EXISTS(postal_box)) OR EXISTS(town)) OR
        EXISTS(region)) OR EXISTS(postal_code)) OR EXISTS(country))
        OR EXISTS(facsimile_number)) OR EXISTS(telephone_number)) OR
        EXISTS(electronic_mail_address)) OR EXISTS(telex_number);
END_ENTITY; -- 10303-41: person_organization_schema

```

```

ENTITY advanced_brep_shape_representation
    SUBTYPE OF (shape_representation);
WHERE
    WR1: SIZEOF(QUERY (it <* SELF.items| NOT (SIZEOF([
        'INTEGRATED_CNC_SCHEMA.MANIFOLD_SOLID_BREP',
        'INTEGRATED_CNC_SCHEMA.FACETED_BREP',
        'INTEGRATED_CNC_SCHEMA.MAPPED_ITEM',
        'INTEGRATED_CNC_SCHEMA.AXIS2_PLACEMENT_3D' ] * TYPEOF(it)) =
        1))) = 0;
    WR2: SIZEOF(QUERY (it <* SELF.items| (SIZEOF([
        'INTEGRATED_CNC_SCHEMA.MANIFOLD_SOLID_BREP',
        'INTEGRATED_CNC_SCHEMA.MAPPED_ITEM' ] * TYPEOF(it)) = 1))) >
        0;
    WR3: SIZEOF(QUERY (msb <* QUERY (it <* SELF.items| (
        'INTEGRATED_CNC_SCHEMA.MANIFOLD_SOLID_BREP' IN TYPEOF(it)))|
        NOT (SIZEOF(QUERY (csh <* msb_shells(msb)| NOT (SIZEOF(QUERY
        (fcs <* csh\connected_face_set.cfs_faces| NOT (
        'INTEGRATED_CNC_SCHEMA.ADVANCED_FACE' IN TYPEOF(fcs)))) = 0))
        ) = 0))) = 0;
    WR4: SIZEOF(QUERY (msb <* QUERY (it <* items| (
        'INTEGRATED_CNC_SCHEMA.MANIFOLD_SOLID_BREP' IN TYPEOF(it)))|
        ('INTEGRATED_CNC_SCHEMA.ORIENTED_CLOSED_SHELL' IN TYPEOF(msb\
        manifold_solid_brep.outer)))) = 0;
    WR5: SIZEOF(QUERY (brv <* QUERY (it <* items| (
        'INTEGRATED_CNC_SCHEMA.BREP_WITH_VOIDS' IN TYPEOF(it)))| NOT
        (SIZEOF(QUERY (csh <* brv\brep_with_voids.voids| csh\
        oriented_closed_shell.orientation)) = 0))) = 0;
    WR6: SIZEOF(QUERY (mi <* QUERY (it <* items| (
        'INTEGRATED_CNC_SCHEMA.MAPPED_ITEM' IN TYPEOF(it)))| NOT (
        'INTEGRATED_CNC_SCHEMA.ADVANCED_BREP_SHAPE_REPRESENTATION' IN
        TYPEOF(mi\mapped_item.mapping_source.mapped_representation))
        )) = 0;
END_ENTITY; -- 10303-514: aic_advanced_brep

```

```

ENTITY advanced_face
    SUBTYPE OF (face_surface);

```



WHERE

```

WR1: SIZEOF([ 'INTEGRATED_CNC_SCHEMA.ELEMENTARY_SURFACE',
              'INTEGRATED_CNC_SCHEMA.B_SPLINE_SURFACE',
              'INTEGRATED_CNC_SCHEMA.SWEPT_SURFACE' ] * TYPEOF(
              face_geometry)) = 1;
WR2: SIZEOF(QUERY (elp_fbnds <* QUERY (bnds <* bounds| (
              'INTEGRATED_CNC_SCHEMA.EDGE_LOOP' IN TYPEOF(bnds.bound)))|
              NOT (SIZEOF(QUERY (oe <* elp_fbnds.bound\path.edge_list| NOT
              ('INTEGRATED_CNC_SCHEMA.EDGE_CURVE' IN TYPEOF(oe\
              oriented_edge.edge_element)))) = 0))) = 0;
WR3: SIZEOF(QUERY (elp_fbnds <* QUERY (bnds <* bounds| (
              'INTEGRATED_CNC_SCHEMA.EDGE_LOOP' IN TYPEOF(bnds.bound)))|
              NOT (SIZEOF(QUERY (oe <* elp_fbnds.bound\path.edge_list| NOT
              (SIZEOF([ 'INTEGRATED_CNC_SCHEMA.LINE',
              'INTEGRATED_CNC_SCHEMA.CONIC',
              'INTEGRATED_CNC_SCHEMA.POLYLINE',
              'INTEGRATED_CNC_SCHEMA.SURFACE_CURVE',
              'INTEGRATED_CNC_SCHEMA.B_SPLINE_CURVE' ] * TYPEOF(oe.
              edge_element\edge_curve.edge_geometry)) = 1)))) = 0))) = 0;
WR4: SIZEOF(QUERY (elp_fbnds <* QUERY (bnds <* bounds| (
              'INTEGRATED_CNC_SCHEMA.EDGE_LOOP' IN TYPEOF(bnds.bound)))|
              NOT (SIZEOF(QUERY (oe <* elp_fbnds.bound\path.edge_list| NOT
              (((('INTEGRATED_CNC_SCHEMA.VERTEX_POINT' IN TYPEOF(oe\edge.
              edge_start)) AND ('INTEGRATED_CNC_SCHEMA.CARTESIAN_POINT' IN
              TYPEOF(oe\edge.edge_start\vertex_point.vertex_geometry))) AND
              (('INTEGRATED_CNC_SCHEMA.VERTEX_POINT' IN TYPEOF(oe\edge.
              edge_end)) AND ('INTEGRATED_CNC_SCHEMA.CARTESIAN_POINT' IN
              TYPEOF(oe\edge.edge_end\vertex_point.vertex_geometry)))))) =
              0))) = 0;
WR5: SIZEOF(QUERY (elp_fbnds <* QUERY (bnds <* bounds| (
              'INTEGRATED_CNC_SCHEMA.EDGE_LOOP' IN TYPEOF(bnds.bound)))| (
              'INTEGRATED_CNC_SCHEMA.ORIENTED_PATH' IN TYPEOF(elp_fbnds.
              bound)))) = 0;
WR6: NOT ('INTEGRATED_CNC_SCHEMA.SWEPT_SURFACE' IN TYPEOF(face_geometry
              )) OR (SIZEOF([ 'INTEGRATED_CNC_SCHEMA.LINE',
              'INTEGRATED_CNC_SCHEMA.CONIC',
              'INTEGRATED_CNC_SCHEMA.POLYLINE',
              'INTEGRATED_CNC_SCHEMA.B_SPLINE_CURVE' ] * TYPEOF(
              face_geometry\swept_surface.swept_curve)) = 1);
WR7: SIZEOF(QUERY (vlp_fbnds <* QUERY (bnds <* bounds| (
              'INTEGRATED_CNC_SCHEMA.VERTEX_LOOP' IN TYPEOF(bnds.bound)))|
              NOT (('INTEGRATED_CNC_SCHEMA.VERTEX_POINT' IN TYPEOF(
              vlp_fbnds\face_bound.bound\vertex_loop.loop_vertex)) AND (
              'INTEGRATED_CNC_SCHEMA.CARTESIAN_POINT' IN TYPEOF(vlp_fbnds\
              face_bound.bound\vertex_loop.loop_vertex\vertex_point.
              vertex_geometry)))))) = 0;
WR8: SIZEOF(QUERY (bnd <* bounds| NOT (SIZEOF([
              'INTEGRATED_CNC_SCHEMA.EDGE_LOOP',
              'INTEGRATED_CNC_SCHEMA.VERTEX_LOOP' ] * TYPEOF(bnd.bound)) =
              1))) = 0;
WR9: SIZEOF(QUERY (elp_fbnds <* QUERY (bnds <* bounds| (
              'INTEGRATED_CNC_SCHEMA.EDGE_LOOP' IN TYPEOF(bnds.bound)))|
              NOT (SIZEOF(QUERY (oe <* elp_fbnds.bound\path.edge_list| (
              'INTEGRATED_CNC_SCHEMA.SURFACE_CURVE' IN TYPEOF(oe\

```

```

        oriented_edge.edge_element\edge_curve.edge_geometry)) AND NOT
        (SIZEOF(QUERY (sc_ag <* oe.edge_element\edge_curve.
        edge_geometry\surface_curve.associated_geometry| NOT (
        'INTEGRATED_CNC_SCHEMA.PCURVE' IN TYPEOF(sc_ag)))) = 0))) = 0;
    WR10: (NOT ('INTEGRATED_CNC_SCHEMA.SWEPT_SURFACE' IN TYPEOF(
        face_geometry)) OR (NOT ('INTEGRATED_CNC_SCHEMA.POLYLINE' IN
        TYPEOF(face_geometry\swept_surface.swept_curve)) OR (SIZEOF(
        face_geometry\swept_surface.swept_curve\polyline.points) >= 3
        ))) AND (SIZEOF(QUERY (elp_fbnds <* QUERY (bnds <* bounds| (
        'INTEGRATED_CNC_SCHEMA.EDGE_LOOP' IN TYPEOF(bnds.bound))) |
        NOT (SIZEOF(QUERY (oe <* elp_fbnds.bound\path.edge_list| (
        'INTEGRATED_CNC_SCHEMA.POLYLINE' IN TYPEOF(oe\oriented_edge.
        edge_element\edge_curve.edge_geometry)) AND NOT (SIZEOF(oe\
        oriented_edge.edge_element\edge_curve.edge_geometry\polyline.
        points) >= 3)))) = 0))) = 0);
END_ENTITY; -- 10303-511: aic_topologically_bounded_surface

ENTITY and_expression
    SUBTYPE OF (multiple_arity_boolean_expression);
END_ENTITY; -- 13584-20: iso13584_expressions_schema

ENTITY angular_location
    SUBTYPE OF (dimensional_location);
    angle_selection : angle_relator;
END_ENTITY; -- 10303-47: shape_dimension_schema

ENTITY angular_size
    SUBTYPE OF (dimensional_size);
    angle_selection : angle_relator;
END_ENTITY; -- 10303-47: shape_dimension_schema

ENTITY angularity_tolerance
    SUBTYPE OF (geometric_tolerance_with_datum_reference);
    WHERE
        WR1: SIZEOF(SELF\geometric_tolerance_with_datum_reference.datum_system)
            < 3;
END_ENTITY; -- 10303-519: aic_geometric_tolerances

ENTITY apex
    SUBTYPE OF (derived_shape_aspect);
END_ENTITY; -- 10303-47: shape_aspect_definition_schema

ENTITY application_context;
    application : label;
    DERIVE
        description : text := get_description_value(SELF);
        id : identifier := get_id_value(SELF);
    INVERSE
        context_elements : SET [1:?] OF application_context_element FOR
            frame_of_reference;
    WHERE
        WR1: SIZEOF(USEDIN(SELF, 'INTEGRATED_CNC_SCHEMA.' +
            'DESCRIPTION_ATTRIBUTE.DESCRIBED_ITEM')) <= 1;

```

```

WR2: SIZEOF(USEDIN(SELF, 'INTEGRATED_CNC_SCHEMA.' +
                    'ID_ATTRIBUTE.IDENTIFIED_ITEM')) <= 1;
END_ENTITY; -- 10303-41: application_context_schema

ENTITY application_context_element
  SUPERTYPE OF (ONEOF(product_context, product_definition_context));
  name : label;
  frame_of_reference : application_context;
END_ENTITY; -- 10303-41: application_context_schema

ENTITY application_protocol_definition;
  status : label;
  application_interpreted_model_schema_name : label;
  application_protocol_year : year_number;
  application : application_context;
END_ENTITY; -- 10303-41: application_context_schema

ENTITY applied_approval_assignment
  SUBTYPE OF (approval_assignment);
  items : SET [1:?] OF approval_item;
END_ENTITY; -- 10303-238: integrated_cnc_schema

ENTITY applied_area
  SUBTYPE OF (shape_aspect);
  WHERE
    WR1: 'INTEGRATED_CNC_SCHEMA.PRODUCT_DEFINITION_SHAPE' IN TYPEOF(SELF.
        of_shape);
    WR2: SIZEOF(QUERY (pd <* USEDIN(SELF,
        'INTEGRATED_CNC_SCHEMA.PROPERTY_DEFINITION.DEFINITION') | NOT
        (SIZEOF(QUERY (pdr <* USEDIN(pd, 'INTEGRATED_CNC_SCHEMA.' +
        'PROPERTY_DEFINITION_REPRESENTATION.DEFINITION') | (
        'INTEGRATED_CNC_SCHEMA.' +
        'SHAPE_REPRESENTATION_WITH_PARAMETERS' IN TYPEOF(pdr.
        used_representation)))) = 1))) = 0;
    WR3: SIZEOF(QUERY (pd <* USEDIN(SELF,
        'INTEGRATED_CNC_SCHEMA.PROPERTY_DEFINITION.DEFINITION') | NOT
        (SIZEOF(QUERY (impl_rep <* QUERY (pdr <* USEDIN(pd,
        'INTEGRATED_CNC_SCHEMA.' +
        'PROPERTY_DEFINITION_REPRESENTATION.DEFINITION') | (
        'INTEGRATED_CNC_SCHEMA.' +
        'SHAPE_REPRESENTATION_WITH_PARAMETERS' IN TYPEOF(pdr.
        used_representation))) | NOT ((2 <= SIZEOF(impl_rep.
        used_representation.items)) AND (SIZEOF(impl_rep.
        used_representation.items) <= 3)))) = 0))) = 0;
    WR4: SIZEOF(QUERY (pd <* USEDIN(SELF,
        'INTEGRATED_CNC_SCHEMA.PROPERTY_DEFINITION.DEFINITION') | (
        SIZEOF(QUERY (pdr <* USEDIN(pd, 'INTEGRATED_CNC_SCHEMA.' +
        'PROPERTY_DEFINITION_REPRESENTATION.DEFINITION') | (
        'INTEGRATED_CNC_SCHEMA.' +
        'SHAPE_REPRESENTATION_WITH_PARAMETERS' IN TYPEOF(pdr.
        used_representation)) AND (SIZEOF(QUERY (srwp_i <* pdr.
        used_representation.items | NOT (srwp_i.name IN [
        'orientation', 'effective length', 'maximum length' ])))) > 0)
        )) = 0))) = 0;

```

```

WR5: SIZEOF(QUERY (pd <* USEDIN(SELF,
    'INTEGRATED_CNC_SCHEMA.PROPERTY_DEFINITION.DEFINITION') | NOT
    (SIZEOF(QUERY (impl_rep <* QUERY (pdr <* USEDIN(pd,
    'INTEGRATED_CNC_SCHEMA.' +
    'PROPERTY_DEFINITION_REPRESENTATION.DEFINITION') | (
    'INTEGRATED_CNC_SCHEMA.' +
    'SHAPE_REPRESENTATION_WITH_PARAMETERS' IN TYPEOF(pdr.
    used_representation))) | NOT (SIZEOF(QUERY (it <* impl_rep.
    used_representation.items | (SIZEOF([
    'INTEGRATED_CNC_SCHEMA.MEASURE_REPRESENTATION_ITEM',
    'INTEGRATED_CNC_SCHEMA.LENGTH_MEASURE_WITH_UNIT' ] * TYPEOF(
    it)) = 2) AND (it.name = 'effective length')) = 1))) = 0)))
    <= 1;

WR6: SIZEOF(QUERY (pd <* USEDIN(SELF,
    'INTEGRATED_CNC_SCHEMA.PROPERTY_DEFINITION.DEFINITION') | NOT
    (SIZEOF(QUERY (impl_rep <* QUERY (pdr <* USEDIN(pd,
    'INTEGRATED_CNC_SCHEMA.' +
    'PROPERTY_DEFINITION_REPRESENTATION.DEFINITION') | (
    'INTEGRATED_CNC_SCHEMA.' +
    'SHAPE_REPRESENTATION_WITH_PARAMETERS' IN TYPEOF(pdr.
    used_representation))) | NOT (SIZEOF(QUERY (it <* impl_rep.
    used_representation.items | (SIZEOF([
    'INTEGRATED_CNC_SCHEMA.MEASURE_REPRESENTATION_ITEM',
    'INTEGRATED_CNC_SCHEMA.LENGTH_MEASURE_WITH_UNIT' ] * TYPEOF(
    it)) = 2) AND (it.name = 'maximum length')) <= 1))) = 0))) =
    0;

WR7: SIZEOF(QUERY (pd <* USEDIN(SELF,
    'INTEGRATED_CNC_SCHEMA.PROPERTY_DEFINITION.DEFINITION') | NOT
    (SIZEOF(QUERY (impl_rep <* QUERY (pdr <* USEDIN(pd,
    'INTEGRATED_CNC_SCHEMA.' +
    'PROPERTY_DEFINITION_REPRESENTATION.DEFINITION') | (
    'INTEGRATED_CNC_SCHEMA.' +
    'SHAPE_REPRESENTATION_WITH_PARAMETERS' IN TYPEOF(pdr.
    used_representation))) | NOT (SIZEOF(QUERY (it <* impl_rep.
    used_representation.items | ('INTEGRATED_CNC_SCHEMA.PLACEMENT'
    IN TYPEOF(it)) AND (it.name = 'orientation')) = 1))) = 0)))
    = 0;

END_ENTITY; -- 10303-522: aic_machining_feature

ENTITY applied_classification_assignment
  SUBTYPE OF (classification_assignment);
  items : SET [1:?] OF classification_item;
END_ENTITY; -- 10303-238: integrated_cnc_schema

ENTITY applied_date_and_time_assignment
  SUBTYPE OF (date_and_time_assignment);
  items : SET [1:?] OF date_and_time_item;
END_ENTITY; -- 10303-238: integrated_cnc_schema

ENTITY applied_date_assignment
  SUBTYPE OF (date_assignment);
  items : SET [1:?] OF date_item;
END_ENTITY; -- 10303-238: integrated_cnc_schema

```

```

ENTITY applied_document_reference
  SUBTYPE OF (document_reference);
  items : SET [1:?] OF document_reference_item;
END_ENTITY; -- 10303-238: integrated_cnc_schema

ENTITY applied_document_usage_constraint_assignment
  SUBTYPE OF (document_usage_constraint_assignment);
  items : SET [1:?] OF document_reference_item;
END_ENTITY; -- 10303-238: integrated_cnc_schema

ENTITY applied_external_identification_assignment
  SUBTYPE OF (external_identification_assignment);
  items : SET [1:?] OF external_identification_item;
END_ENTITY; -- 10303-238: integrated_cnc_schema

ENTITY applied_identification_assignment
  SUBTYPE OF (identification_assignment);
  items : SET [1:?] OF identification_item;
END_ENTITY; -- 10303-238: integrated_cnc_schema

ENTITY applied_organization_assignment
  SUBTYPE OF (organization_assignment);
  items : SET [1:?] OF organization_item;
END_ENTITY; -- 10303-238: integrated_cnc_schema

ENTITY applied_person_and_organization_assignment
  SUBTYPE OF (person_and_organization_assignment);
  items : SET [1:?] OF person_and_organization_item;
END_ENTITY; -- 10303-238: integrated_cnc_schema

ENTITY applied_security_classification_assignment
  SUBTYPE OF (security_classification_assignment);
  items : SET [1:?] OF security_classification_item;
END_ENTITY; -- 10303-238: integrated_cnc_schema

ENTITY approval;
  status : approval_status;
  level : label;
END_ENTITY; -- 10303-41: approval_schema

ENTITY approval_assignment
  ABSTRACT SUPERTYPE;
  assigned_approval : approval;
  DERIVE
    role : object_role := get_role(SELF);
  WHERE
    WR1: SIZEOF(USEDIN(SELF, 'INTEGRATED_CNC_SCHEMA.' +
      'ROLE_ASSOCIATION.ITEM_WITH_ROLE')) <= 1;
END_ENTITY; -- 10303-41: management_resources_schema

ENTITY approval_date_time;
  date_time : date_time_select;
  dated_approval : approval;
  DERIVE

```

ISO 10303-238:2007(E)

```

    role : object_role := get_role(SELF);
WHERE
    WR1: SIZEOF(USEDIN(SELF, 'INTEGRATED_CNC_SCHEMA.' +
        'ROLE_ASSOCIATION.ITEM_WITH_ROLE')) <= 1;
END_ENTITY; -- 10303-41: approval_schema

ENTITY approval_person_organization;
    person_organization : person_organization_select;
    authorized_approval : approval;
    role                  : approval_role;
END_ENTITY; -- 10303-41: approval_schema

ENTITY approval_relationship;
    name                  : label;
    description           : OPTIONAL text;
    relating_approval     : approval;
    related_approval      : approval;
END_ENTITY; -- 10303-41: approval_schema

ENTITY approval_role;
    role : label;
DERIVE
    description : text := get_description_value(SELF);
WHERE
    WR1: SIZEOF(USEDIN(SELF, 'INTEGRATED_CNC_SCHEMA.' +
        'DESCRIPTION_ATTRIBUTE.DESCRIBED_ITEM')) <= 1;
END_ENTITY; -- 10303-41: approval_schema

ENTITY approval_status;
    name : label;
END_ENTITY; -- 10303-41: approval_schema

ENTITY assembly_component_usage
    SUPERTYPE OF (next_assembly_usage_occurrence)
    SUBTYPE OF (product_definition_usage);
    reference_designator : OPTIONAL identifier;
END_ENTITY; -- 10303-44: product_structure_schema

ENTITY axis1_placement
    SUBTYPE OF (placement);
    axis : OPTIONAL direction;
DERIVE
    z : direction := NVL(normalise(axis), dummy_gri || direction([ 0.0, 0.0
        , 1.0 ]));
WHERE
    WR1: SELF\geometric_representation_item.dim = 3;
END_ENTITY; -- 10303-42: geometry_schema

ENTITY axis2_placement_2d
    SUBTYPE OF (placement);
    ref_direction : OPTIONAL direction;
DERIVE
    p : LIST [2:2] OF direction := build_2axes(ref_direction);
WHERE

```

```

    WR1: SELF\geometric_representation_item.dim = 2;
END_ENTITY; -- 10303-42: geometry_schema

ENTITY axis2_placement_3d
  SUBTYPE OF (placement);
  axis          : OPTIONAL direction;
  ref_direction : OPTIONAL direction;
  DERIVE
  p : LIST [3:3] OF direction := build_axes(axis, ref_direction);
  WHERE
  WR1: SELF\placement.location.dim = 3;
  WR2: NOT EXISTS(axis) OR (axis.dim = 3);
  WR3: NOT EXISTS(ref_direction) OR (ref_direction.dim = 3);
  WR4: (NOT EXISTS(axis) OR NOT EXISTS(ref_direction)) OR (cross_product(
    axis, ref_direction).magnitude > 0.0);
END_ENTITY; -- 10303-42: geometry_schema

ENTITY b_spline_curve
  SUPERTYPE OF (ONEOF(uniform_curve, b_spline_curve_with_knots,
    quasi_uniform_curve, bezier_curve) ANDOR rational_b_spline_curve)
  SUBTYPE OF (bounded_curve);
  degree          : INTEGER;
  control_points_list : LIST [2:?] OF cartesian_point;
  curve_form      : b_spline_curve_form;
  closed_curve    : LOGICAL;
  self_intersect  : LOGICAL;
  DERIVE
  upper_index_on_control_points : INTEGER := SIZEOF(control_points_list)
    - 1;
  control_points                : ARRAY [0:upper_index_on_control_points]
    OF cartesian_point := list_to_array(
    control_points_list, 0,
    upper_index_on_control_points);
  WHERE
  WR1: ((( 'INTEGRATED_CNC_SCHEMA.UNIFORM_CURVE' IN TYPEOF(SELF)) OR (
    'INTEGRATED_CNC_SCHEMA.QUASI_UNIFORM_CURVE' IN TYPEOF(SELF)))
    OR ('INTEGRATED_CNC_SCHEMA.BEZIER_CURVE' IN TYPEOF(SELF)))
    OR ('INTEGRATED_CNC_SCHEMA.B_SPLINE_CURVE_WITH_KNOTS' IN
    TYPEOF(SELF));
END_ENTITY; -- 10303-42: geometry_schema

ENTITY b_spline_curve_with_knots
  SUBTYPE OF (b_spline_curve);
  knot_multiplicities : LIST [2:?] OF INTEGER;
  knots               : LIST [2:?] OF parameter_value;
  knot_spec           : knot_type;
  DERIVE
  upper_index_on_knots : INTEGER := SIZEOF(knots);
  WHERE
  WR1: constraints_param_b_spline(degree, upper_index_on_knots,
    upper_index_on_control_points, knot_multiplicities, knots);
  WR2: SIZEOF(knot_multiplicities) = upper_index_on_knots;
END_ENTITY; -- 10303-42: geometry_schema

```

```

ENTITY b_spline_surface
  SUPERTYPE OF (ONEOF(b_spline_surface_with_knots, uniform_surface,
    quasi_uniform_surface, bezier_surface) ANDOR
    rational_b_spline_surface)
  SUBTYPE OF (bounded_surface);
  u_degree      : INTEGER;
  v_degree      : INTEGER;
  control_points_list : LIST [2:?] OF LIST [2:?] OF cartesian_point;
  surface_form   : b_spline_surface_form;
  u_closed       : LOGICAL;
  v_closed       : LOGICAL;
  self_intersect  : LOGICAL;
  DERIVE
    u_upper      : INTEGER := SIZEOF(control_points_list) - 1;
    v_upper      : INTEGER := SIZEOF(control_points_list[1]) - 1;
    control_points : ARRAY [0:u_upper] OF ARRAY [0:v_upper] OF
      cartesian_point := make_array_of_array(
        control_points_list, 0, u_upper, 0, v_upper);
  WHERE
    WR1: (((('INTEGRATED_CNC_SCHEMA.UNIFORM_SURFACE' IN TYPEOF(SELF)) OR (
      'INTEGRATED_CNC_SCHEMA.QUASI_UNIFORM_SURFACE' IN TYPEOF(SELF)
    )) OR ('INTEGRATED_CNC_SCHEMA.BEZIER_SURFACE' IN TYPEOF(SELF)
    )) OR ('INTEGRATED_CNC_SCHEMA.B_SPLINE_SURFACE_WITH_KNOTS' IN
      TYPEOF(SELF)));
END_ENTITY; -- 10303-42: geometry_schema

ENTITY b_spline_surface_with_knots
  SUBTYPE OF (b_spline_surface);
  u_multiplicities : LIST [2:?] OF INTEGER;
  v_multiplicities : LIST [2:?] OF INTEGER;
  u_knots          : LIST [2:?] OF parameter_value;
  v_knots          : LIST [2:?] OF parameter_value;
  knot_spec        : knot_type;
  DERIVE
    knot_u_upper : INTEGER := SIZEOF(u_knots);
    knot_v_upper : INTEGER := SIZEOF(v_knots);
  WHERE
    WR1: constraints_param_b_spline(SELF\b_spline_surface.u_degree,
      knot_u_upper, SELF\b_spline_surface.u_upper, u_multiplicities
      , u_knots);
    WR2: constraints_param_b_spline(SELF\b_spline_surface.v_degree,
      knot_v_upper, SELF\b_spline_surface.v_upper, v_multiplicities
      , v_knots);
    WR3: SIZEOF(u_multiplicities) = knot_u_upper;
    WR4: SIZEOF(v_multiplicities) = knot_v_upper;
END_ENTITY; -- 10303-42: geometry_schema

ENTITY back_boring_operation
  SUBTYPE OF (drilling_type_operation);
  WHERE
    WR1: (0 = SIZEOF (QUERY (amr <* get_relating_amr (SELF) |
      ('INTEGRATED_CNC_SCHEMA.MACHINING_FUNCTIONS_RELATIONSHIP'
      IN TYPEOF (amr)) AND NOT
      (verify_required_action_property

```



```

        (amr.related_method, 'oriented spindle stop'))));
END_ENTITY; -- 10303-238: integrated_cnc_schema

ENTITY bezier_curve
  SUBTYPE OF (b_spline_curve);
END_ENTITY; -- 10303-42: geometry_schema

ENTITY bezier_surface
  SUBTYPE OF (b_spline_surface);
END_ENTITY; -- 10303-42: geometry_schema

ENTITY binary_boolean_expression
  ABSTRACT SUPERTYPE OF (xor_expression)
  SUBTYPE OF (boolean_expression, binary_generic_expression);
END_ENTITY; -- 13584-20: iso13584_expressions_schema

ENTITY binary_generic_expression
  ABSTRACT SUPERTYPE
  SUBTYPE OF (generic_expression);
  operands : LIST [2:2] OF generic_expression;
END_ENTITY; -- 13584-20: iso13584_generic_expressions_schema

ENTITY block
  SUBTYPE OF (geometric_representation_item);
  position : axis2_placement_3d;
  x        : positive_length_measure;
  y        : positive_length_measure;
  z        : positive_length_measure;
END_ENTITY; -- 10303-42: geometric_model_schema

ENTITY block_shape_representation
  SUBTYPE OF (shape_representation_with_parameters);
  WHERE
    WR1: SIZEOF(SELF.items) = 4;
    WR2: SIZEOF(QUERY (it <* SELF.items| ('INTEGRATED_CNC_SCHEMA.PLACEMENT'
      IN TYPEOF(it)) AND (it.name = 'orientation')))) = 1;
    WR3: SIZEOF(QUERY (it <* SELF.items| (SIZEOF([
      'INTEGRATED_CNC_SCHEMA.MEASURE_REPRESENTATION_ITEM',
      'INTEGRATED_CNC_SCHEMA.LENGTH_MEASURE_WITH_UNIT' ] * TYPEOF(
      it)) = 2) AND (it.name = 'length')))) = 1;
    WR4: SIZEOF(QUERY (it <* SELF.items| (SIZEOF([
      'INTEGRATED_CNC_SCHEMA.MEASURE_REPRESENTATION_ITEM',
      'INTEGRATED_CNC_SCHEMA.LENGTH_MEASURE_WITH_UNIT' ] * TYPEOF(
      it)) = 2) AND (it.name = 'width')))) = 1;
    WR5: SIZEOF(QUERY (it <* SELF.items| (SIZEOF([
      'INTEGRATED_CNC_SCHEMA.MEASURE_REPRESENTATION_ITEM',
      'INTEGRATED_CNC_SCHEMA.LENGTH_MEASURE_WITH_UNIT' ] * TYPEOF(
      it)) = 2) AND (it.name = 'height')))) = 1;
END_ENTITY; -- 10303-238: integrated_cnc_schema

ENTITY boolean_expression
  ABSTRACT SUPERTYPE OF (ONEOF (unary_boolean_expression,
    binary_boolean_expression, multiple_arity_boolean_expression,
    comparison_expression))

```

ISO 10303-238:2007(E)

```

SUBTYPE OF (expression);
END_ENTITY; -- 13584-20: iso13584_expressions_schema

ENTITY boring_operation
SUBTYPE OF (drilling_type_operation);
WHERE
WR1: (SELF.description IN ['boring','reaming']);

WR2: (verify_optional_action_property      (SELF, 'spindle stop')) AND
      (verify_enumeration_action_property  (SELF, 'spindle stop',
      ['spindle stop at bottom', 'spindle nonstop']));

WR3: (verify_optional_action_property      (SELF, 'testcut depth')) AND
      (verify_length_measure_action_property (SELF, 'testcut depth'));

WR4: (verify_optional_action_property      (SELF, 'waiting position')) AND
      (verify_rep_item_for_action_property (SELF, 'waiting position',
      ['INTEGRATED_CNC_SCHEMA.CARTESIAN_POINT']));
END_ENTITY; -- 10303-238: integrated_cnc_schema

ENTITY boss
SUBTYPE OF (feature_definition);
WHERE
WR1: SELF\characterized_object.description IN [ 'circular', 'complex',
      'rectangular' ];
WR2: SIZEOF(QUERY (pds <* QUERY (pd <* USEDIN(SELF,
      'INTEGRATED_CNC_SCHEMA.PROPERTY_DEFINITION.DEFINITION')| (
      'INTEGRATED_CNC_SCHEMA.PRODUCT_DEFINITION_SHAPE' IN TYPEOF(pd
      )))| NOT (SIZEOF(QUERY (sa_occ <* USEDIN(pds,
      'INTEGRATED_CNC_SCHEMA.SHAPE_ASPECT.OF_SHAPE')| (sa_occ.
      description = 'boss height occurrence') AND (SIZEOF(QUERY (
      sdr <* QUERY (sar <* USEDIN(sa_occ,
      'INTEGRATED_CNC_SCHEMA.SHAPE_ASPECT_RELATIONSHIP.' +
      'RELATED_SHAPE_ASPECT')| (sar.description =
      'path feature component usage') AND ('INTEGRATED_CNC_SCHEMA.'
      + 'SHAPE_DEFINING_RELATIONSHIP' IN TYPEOF(sar))))| ((
      'INTEGRATED_CNC_SCHEMA.PATH_FEATURE_COMPONENT' IN TYPEOF(sdr.
      relating_shape_aspect)) AND (sdr.relating_shape_aspect.
      description = 'linear')) AND (sdr.name = 'boss height')))) = 1
      ))) = 1))) = 0;
WR3: SIZEOF(QUERY (pd <* USEDIN(SELF,
      'INTEGRATED_CNC_SCHEMA.PROPERTY_DEFINITION.DEFINITION')| (
      SIZEOF(QUERY (pdr <* USEDIN(pd, 'INTEGRATED_CNC_SCHEMA.' +
      'PROPERTY_DEFINITION_REPRESENTATION.DEFINITION')| (
      'INTEGRATED_CNC_SCHEMA.' +
      'SHAPE_REPRESENTATION_WITH_PARAMETERS' IN TYPEOF(pdr.
      used_representation)) AND ((1 <= SIZEOF(pdr.
      used_representation.items)) AND (SIZEOF(pdr.
      used_representation.items) <= 2)))) = 1))) = 1;
WR4: SIZEOF(QUERY (pd <* USEDIN(SELF,
      'INTEGRATED_CNC_SCHEMA.PROPERTY_DEFINITION.DEFINITION')| (
      SIZEOF(QUERY (pdr <* USEDIN(pd, 'INTEGRATED_CNC_SCHEMA.' +
      'PROPERTY_DEFINITION_REPRESENTATION.DEFINITION')| (
      'INTEGRATED_CNC_SCHEMA.' +

```

```

'SHAPE_REPRESENTATION_WITH_PARAMETERS' IN TYPEOF(pdr.
used_representation)) AND (SIZEOF(QUERY (srwp_i <* pdr.
used_representation.items| (srwp_i.name = 'orientation') OR (
srwp_i.name = 'fillet radius')))) = SIZEOF(pdr.
used_representation.items))) = 1))) = 1;
WR5: SIZEOF(QUERY (pd <* USEDIN(SELF,
'INTEGRATED_CNC_SCHEMA.PROPERTY_DEFINITION.DEFINITION')| NOT
(SIZEOF(QUERY (impl_rep <* QUERY (pdr <* USEDIN(pd,
'INTEGRATED_CNC_SCHEMA.' +
'PROPERTY_DEFINITION_REPRESENTATION.DEFINITION')| (
'INTEGRATED_CNC_SCHEMA.' +
'SHAPE_REPRESENTATION_WITH_PARAMETERS' IN TYPEOF(pdr.
used_representation)))| NOT (SIZEOF(QUERY (it <* impl_rep.
used_representation.items| (SIZEOF([
'INTEGRATED_CNC_SCHEMA.MEASURE_REPRESENTATION_ITEM',
'INTEGRATED_CNC_SCHEMA.LENGTH_MEASURE_WITH_UNIT' ] * TYPEOF(
it)) = 2) AND (it.name = 'fillet radius')))) <= 1))) = 0))) =
0;
WR6: NOT (SELF\characterized_object.description = 'circular') OR (
SIZEOF(QUERY (pds <* QUERY (pd <* USEDIN(SELF,
'INTEGRATED_CNC_SCHEMA.PROPERTY_DEFINITION.DEFINITION')| (
'INTEGRATED_CNC_SCHEMA.PRODUCT_DEFINITION_SHAPE' IN TYPEOF(pd
)))| NOT (SIZEOF(QUERY (sa_occ <* USEDIN(pds,
'INTEGRATED_CNC_SCHEMA.SHAPE_ASPECT.OF_SHAPE')| (sa_occ.
description = 'circular profile occurrence') AND (SIZEOF(
QUERY (sdr <* QUERY (sar <* USEDIN(sa_occ,
'INTEGRATED_CNC_SCHEMA.SHAPE_ASPECT_RELATIONSHIP.' +
'RELATED_SHAPE_ASPECT')| (sar.description = 'profile usage')
AND ('INTEGRATED_CNC_SCHEMA.SHAPE_DEFINING_RELATIONSHIP' IN
TYPEOF(sar)))| (
'INTEGRATED_CNC_SCHEMA.CIRCULAR_CLOSED_PROFILE' IN TYPEOF(sdr
.relating_shape_aspect)))) = 1))) = 1))) = 0);
WR7: SIZEOF(QUERY (pds <* QUERY (pd <* USEDIN(SELF,
'INTEGRATED_CNC_SCHEMA.PROPERTY_DEFINITION.DEFINITION')| (
'INTEGRATED_CNC_SCHEMA.PRODUCT_DEFINITION_SHAPE' IN TYPEOF(pd
)))| NOT (SIZEOF(QUERY (sa_occ <* USEDIN(pds,
'INTEGRATED_CNC_SCHEMA.SHAPE_ASPECT.OF_SHAPE')| (sa_occ.
description = 'top condition occurrence') AND (SIZEOF(QUERY (
fcr <* QUERY (sar <* USEDIN(sa_occ,
'INTEGRATED_CNC_SCHEMA.SHAPE_ASPECT_RELATIONSHIP.RELATED_SHAPE_ASPECT'
)| (sar.description = 'boss top usage') AND (
'INTEGRATED_CNC_SCHEMA.FEATURE_COMPONENT_RELATIONSHIP' IN
TYPEOF(sar)))| ('INTEGRATED_CNC_SCHEMA.BOSS_TOP' IN TYPEOF(
fcr.relating_shape_aspect)))) = 1))) = 1))) = 0;
WR8: NOT (SELF\characterized_object.description = 'circular') OR (
SIZEOF(QUERY (pds <* QUERY (pd <* USEDIN(SELF,
'INTEGRATED_CNC_SCHEMA.PROPERTY_DEFINITION.DEFINITION')| (
'INTEGRATED_CNC_SCHEMA.PRODUCT_DEFINITION_SHAPE' IN TYPEOF(pd
)))| NOT (SIZEOF(QUERY (sa_occ <* USEDIN(pds,
'INTEGRATED_CNC_SCHEMA.SHAPE_ASPECT.OF_SHAPE')| (sa_occ.
description = 'change in diameter occurrence') AND (SIZEOF(
QUERY (fcr <* QUERY (sar <* USEDIN(sa_occ,
'INTEGRATED_CNC_SCHEMA.SHAPE_ASPECT_RELATIONSHIP.' +

```

```

'RELATED_SHAPE_ASPECT')| (sar.description = 'taper usage')
AND ('INTEGRATED_CNC_SCHEMA.FEATURE_COMPONENT_RELATIONSHIP'
IN TYPEOF(sar))| ('INTEGRATED_CNC_SCHEMA.TAPER' IN TYPEOF(
fcr.related_shape_aspect)) AND ('INTEGRATED_CNC_SCHEMA.BOSS'
IN TYPEOF(fcr.relater_shape_aspect)))) = 1))) <= 1))) = 0);
WR9: NOT (SELF\characterized_object.description = 'complex') OR (SIZEOF
(QUERY (pds <* QUERY (pd <* USEDIN(SELF,
'INTEGRATED_CNC_SCHEMA.PROPERTY_DEFINITION.DEFINITION')| (
'INTEGRATED_CNC_SCHEMA.PRODUCT_DEFINITION_SHAPE' IN TYPEOF(pd
)))| NOT (SIZEOF(QUERY (sa_occ <* USEDIN(pds,
'INTEGRATED_CNC_SCHEMA.SHAPE_ASPECT.OF_SHAPE')| (sa_occ.
description = 'enclosed boundary occurrence') AND (SIZEOF(
QUERY (sdr <* QUERY (sar <* USEDIN(sa_occ,
'INTEGRATED_CNC_SCHEMA.SHAPE_ASPECT_RELATIONSHIP.' +
'RELATED_SHAPE_ASPECT')| (sar.description = 'profile usage')
AND ('INTEGRATED_CNC_SCHEMA.SHAPE_DEFINING_RELATIONSHIP' IN
TYPEOF(sar))| (SIZEOF([
'INTEGRATED_CNC_SCHEMA.NGON_CLOSED_PROFILE',
'INTEGRATED_CNC_SCHEMA.CLOSED_PATH_PROFILE' ] * TYPEOF(sdr.
relater_shape_aspect)) = 1))) = 1))) = 1))) = 0);
WR10: NOT (SELF\characterized_object.description IN [ 'complex',
'rectangular' ]) OR (SIZEOF(QUERY (pds <* QUERY (pd <* USEDIN
(SELF, 'INTEGRATED_CNC_SCHEMA.PROPERTY_DEFINITION.DEFINITION'
)| ('INTEGRATED_CNC_SCHEMA.PRODUCT_DEFINITION_SHAPE' IN
TYPEOF(pd)))| NOT (SIZEOF(QUERY (sa_occ <* USEDIN(pds,
'INTEGRATED_CNC_SCHEMA.SHAPE_ASPECT.OF_SHAPE')| (sa_occ.
description = 'change in boundary occurrence') AND (SIZEOF(
QUERY (fcr <* QUERY (sar <* USEDIN(sa_occ,
'INTEGRATED_CNC_SCHEMA.SHAPE_ASPECT_RELATIONSHIP.' +
'RELATING_SHAPE_ASPECT')| (sar.description = 'taper usage')
AND ('INTEGRATED_CNC_SCHEMA.FEATURE_COMPONENT_RELATIONSHIP'
IN TYPEOF(sar))| (('INTEGRATED_CNC_SCHEMA.TAPER' IN TYPEOF(
fcr.related_shape_aspect)) AND ('INTEGRATED_CNC_SCHEMA.BOSS'
IN TYPEOF(fcr.relater_shape_aspect))) AND (fcr.
related_shape_aspect.description IN [ 'angle taper',
'directed taper' ])))) = 1))) <= 1))) = 0);
WR11: NOT (SELF\characterized_object.description = 'rectangular') OR (
SIZEOF(QUERY (pds <* QUERY (pd <* USEDIN(SELF,
'INTEGRATED_CNC_SCHEMA.PROPERTY_DEFINITION.DEFINITION')| (
'INTEGRATED_CNC_SCHEMA.PRODUCT_DEFINITION_SHAPE' IN TYPEOF(pd
)))| NOT (SIZEOF(QUERY (sa_occ <* USEDIN(pds,
'INTEGRATED_CNC_SCHEMA.SHAPE_ASPECT.OF_SHAPE')| (sa_occ.
description = 'rectangular profile occurrence') AND (SIZEOF(
QUERY (sdr <* QUERY (sar <* USEDIN(sa_occ,
'INTEGRATED_CNC_SCHEMA.SHAPE_ASPECT_RELATIONSHIP.' +
'RELATED_SHAPE_ASPECT')| (sar.description = 'profile usage')
AND ('INTEGRATED_CNC_SCHEMA.SHAPE_DEFINING_RELATIONSHIP' IN
TYPEOF(sar))| (
'INTEGRATED_CNC_SCHEMA.RECTANGULAR_CLOSED_PROFILE' IN TYPEOF(
sdr.relater_shape_aspect)))) = 1))) = 1))) = 0);
WR12: SIZEOF(QUERY (pdr <* get_property_definition_representations(SELF
)| ('INTEGRATED_CNC_SCHEMA.PLANAR_SHAPE_REPRESENTATION' IN
TYPEOF(pdr.used_representation)) AND (pdr.used_representation
.name = 'maximum feature limit')) >= 0;

```

```

END_ENTITY; -- 10303-522: aic_machining_feature

ENTITY boss_top
  SUBTYPE OF (shape_aspect);
  WHERE
    WR1: 'INTEGRATED_CNC_SCHEMA.FEATURE_COMPONENT_DEFINITION' IN TYPEOF(
      SELF.of_shape.definition);
    WR2: SELF.description IN [ 'planar', 'complex' ];
    WR3: NOT (SELF.description = 'planar') OR (SIZEOF(QUERY (pd <* USEDIN(
      SELF, 'INTEGRATED_CNC_SCHEMA.PROPERTY_DEFINITION.DEFINITION')
      | NOT (SIZEOF(QUERY (pdr <* USEDIN(pd,
      'INTEGRATED_CNC_SCHEMA.' +
      'PROPERTY_DEFINITION_REPRESENTATION.DEFINITION') | (
      'INTEGRATED_CNC_SCHEMA.DIRECTION_SHAPE_REPRESENTATION' IN
      TYPEOF(pdr.used_representation)))) = 1))) = 0);
    WR4: NOT (SELF.description = 'planar') OR (SIZEOF(QUERY (pd <* USEDIN(
      SELF, 'INTEGRATED_CNC_SCHEMA.PROPERTY_DEFINITION.DEFINITION')
      | NOT (SIZEOF(QUERY (pdr <* USEDIN(pd,
      'INTEGRATED_CNC_SCHEMA.' +
      'PROPERTY_DEFINITION_REPRESENTATION.DEFINITION') | (
      'INTEGRATED_CNC_SCHEMA.LOCATION_SHAPE_REPRESENTATION' IN
      TYPEOF(pdr.used_representation)))) = 1))) = 0);
    WR5: NOT (SELF.description = 'complex') OR (SIZEOF(QUERY (pd <* USEDIN(
      SELF, 'INTEGRATED_CNC_SCHEMA.PROPERTY_DEFINITION.DEFINITION')
      | NOT (SIZEOF(QUERY (pdr <* USEDIN(pd,
      'INTEGRATED_CNC_SCHEMA.' +
      'PROPERTY_DEFINITION_REPRESENTATION.DEFINITION') | (
      'INTEGRATED_CNC_SCHEMA.FACE_SHAPE_REPRESENTATION' IN TYPEOF(
      pdr.used_representation)))) = 1))) = 0);
    WR6: SIZEOF(QUERY (fcr <* QUERY (sar <* USEDIN(SELF,
      'INTEGRATED_CNC_SCHEMA.SHAPE_ASPECT_RELATIONSHIP.' +
      'RELATING_SHAPE_ASPECT') | ((sar.description =
      'boss top usage') AND (sar.name IN [ 'boss height start',
      'boss height end' ])) AND (
      'INTEGRATED_CNC_SCHEMA.FEATURE_COMPONENT_RELATIONSHIP' IN
      TYPEOF(sar))) | ((fcr.related_shape_aspect.description =
      'top condition occurrence') AND ('INTEGRATED_CNC_SCHEMA.BOSS'
      IN TYPEOF(fcr.related_shape_aspect.of_shape.definition)))
      AND ('INTEGRATED_CNC_SCHEMA.BOSS_TOP' IN TYPEOF(fcr.
      relating_shape_aspect)))) >= 1;
    WR7: SIZEOF(QUERY (pd <* USEDIN(SELF,
      'INTEGRATED_CNC_SCHEMA.PROPERTY_DEFINITION.DEFINITION') | NOT
      (SIZEOF(QUERY (pdr <* USEDIN(pd, 'INTEGRATED_CNC_SCHEMA.' +
      'PROPERTY_DEFINITION_REPRESENTATION.DEFINITION') | (
      'INTEGRATED_CNC_SCHEMA.' +
      'SHAPE_REPRESENTATION_WITH_PARAMETERS' IN TYPEOF(pdr.
      used_representation)))) <= 1))) = 0;
    WR8: SIZEOF(QUERY (pd <* USEDIN(SELF,
      'INTEGRATED_CNC_SCHEMA.PROPERTY_DEFINITION.DEFINITION') | NOT
      (SIZEOF(QUERY (impl_rep <* QUERY (pdr <* USEDIN(pd,
      'INTEGRATED_CNC_SCHEMA.' +
      'PROPERTY_DEFINITION_REPRESENTATION.DEFINITION') | (
      'INTEGRATED_CNC_SCHEMA.' +
      'SHAPE_REPRESENTATION_WITH_PARAMETERS' IN TYPEOF(pdr.

```

```

        used_representation)))| NOT (SIZEOF(impl_rep.
        used_representation.items) = 1))) = 0))) = 0;
WR9: SIZEOF(QUERY (pd <* USEDIN(SELF,
        'INTEGRATED_CNC_SCHEMA.PROPERTY_DEFINITION.DEFINITION')| NOT
        (SIZEOF(QUERY (impl_rep <* QUERY (pdr <* USEDIN(pd,
        'INTEGRATED_CNC_SCHEMA.' +
        'PROPERTY_DEFINITION_REPRESENTATION.DEFINITION')| (
        'INTEGRATED_CNC_SCHEMA.' +
        'SHAPE_REPRESENTATION_WITH_PARAMETERS' IN TYPEOF(pdr.
        used_representation)))| NOT (SIZEOF(QUERY (it <* impl_rep.
        used_representation.items| (SIZEOF([
        'INTEGRATED_CNC_SCHEMA.MEASURE_REPRESENTATION_ITEM',
        'INTEGRATED_CNC_SCHEMA.LENGTH_MEASURE_WITH_UNIT' ] * TYPEOF(
        it)) = 2) AND (it.name = 'top radius')) <= 1))) = 0))) = 0;
END_ENTITY; -- 10303-522: aic_machining_feature

ENTITY bottom_and_side_milling_operation
  SUBTYPE OF (milling_type_operation);
  WHERE
  WR1: (SELF.description IN ['roughing','finishing']);

  WR2: (verify_optional_action_property (SELF, 'axial cutting depth')) AND
        (verify_length_measure_action_property (SELF, 'axial cutting depth'));

  WR3: (verify_optional_action_property (SELF, 'radial cutting depth')) AND
        (verify_length_measure_action_property (SELF, 'radial cutting depth'));

  WR4: (verify_optional_action_property (SELF, 'allowance side')) AND
        (verify_length_measure_action_property (SELF, 'allowance side'));

  WR5: (verify_optional_action_property (SELF, 'allowance bottom')) AND
        (verify_length_measure_action_property (SELF, 'allowance bottom'));

  WR6: NOT (SELF.description = 'roughing') OR
        ((verify_required_action_property (SELF, 'allowance side')) AND
        (verify_required_action_property (SELF, 'allowance bottom')));
END_ENTITY; -- 10303-238: integrated_cnc_schema

ENTITY boundary_curve
  SUBTYPE OF (composite_curve_on_surface);
  WHERE
  WR1: SELF\composite_curve.closed_curve;
END_ENTITY; -- 10303-42: geometry_schema

ENTITY bounded_curve
  SUPERTYPE OF (ONEOF(polyline, b_spline_curve, trimmed_curve,
        bounded_pcurve, bounded_surface_curve, composite_curve))
  SUBTYPE OF (curve);
END_ENTITY; -- 10303-42: geometry_schema

ENTITY bounded_pcurve
  SUBTYPE OF (pcurve, bounded_curve);
  WHERE
  WR1: 'INTEGRATED_CNC_SCHEMA.BOUNDED_CURVE' IN TYPEOF(SELF\pcurve.

```

```

        reference_to_curve.items[1]);
END_ENTITY; -- 10303-42: geometry_schema

ENTITY bounded_surface
  SUPERTYPE OF (ONEOF(b_spline_surface, rectangular_trimmed_surface,
    curve_bounded_surface, rectangular_composite_surface))
  SUBTYPE OF (surface);
END_ENTITY; -- 10303-42: geometry_schema

ENTITY bounded_surface_curve
  SUBTYPE OF (surface_curve, bounded_curve);
  WHERE
    WR1: 'INTEGRATED_CNC_SCHEMA.BOUNDED_CURVE' IN TYPEOF(SELF\surface_curve
      .curve_3d);
END_ENTITY; -- 10303-42: geometry_schema

ENTITY brep_with_voids
  SUBTYPE OF (manifold_solid_brep);
  voids : SET [1:?] OF oriented_closed_shell;
END_ENTITY; -- 10303-42: geometric_model_schema

ENTITY calendar_date
  SUBTYPE OF (date);
  day_component : day_in_month_number;
  month_component : month_in_year_number;
  WHERE
    WR1: valid_calendar_date(SELF);
END_ENTITY; -- 10303-41: date_time_schema

ENTITY cartesian_point
  SUBTYPE OF (point);
  coordinates : LIST [1:3] OF length_measure;
END_ENTITY; -- 10303-42: geometry_schema

ENTITY cartesian_transformation_operator
  SUPERTYPE OF (cartesian_transformation_operator_3d)
  SUBTYPE OF (geometric_representation_item,
    functionally_defined_transformation);
  axis1 : OPTIONAL direction;
  axis2 : OPTIONAL direction;
  local_origin : cartesian_point;
  scale : OPTIONAL REAL;
  DERIVE
    scl : REAL := NVL(scale, 1.0);
  WHERE
    WR1: scl > 0.0;
END_ENTITY; -- 10303-42: geometry_schema

ENTITY cartesian_transformation_operator_3d
  SUBTYPE OF (cartesian_transformation_operator);
  axis3 : OPTIONAL direction;
  DERIVE
    u : LIST [3:3] OF direction := base_axis(3, SELF\
      cartesian_transformation_operator.axis1, SELF\

```

```

        cartesian_transformation_operator.axis2, axis3);
WHERE
    WR1: SELF\geometric_representation_item.dim = 3;
END_ENTITY; -- 10303-42: geometry_schema

ENTITY centre_of_symmetry
    SUBTYPE OF (derived_shape_aspect);
WHERE
    WR1: SIZEOF(QUERY (sadr <* SELF\derived_shape_aspect.
        deriving_relationships| NOT (
            'INTEGRATED_CNC_SCHEMA.SYMMETRIC_SHAPE_ASPECT' IN TYPEOF(sadr
            \shape_aspect_relationship.related_shape_aspect)))) = 0;
END_ENTITY; -- 10303-47: shape_aspect_definition_schema

ENTITY chamfer
    SUBTYPE OF (transition_feature);
WHERE
    WR1: SIZEOF(QUERY (pd <* USEDIN(SELF,
        'INTEGRATED_CNC_SCHEMA.PROPERTY_DEFINITION.DEFINITION')| NOT
        (SIZEOF(QUERY (pdr <* USEDIN(pd, 'INTEGRATED_CNC_SCHEMA.' +
        'PROPERTY_DEFINITION_REPRESENTATION.DEFINITION')| (
        'INTEGRATED_CNC_SCHEMA.FACE_SHAPE_REPRESENTATION' IN TYPEOF(
        pdr.used_representation)) AND (pdr.used_representation.name =
        'chamfer face')) <= 1))) = 0;
    WR2: SIZEOF(QUERY (fcr <* QUERY (sar <* USEDIN(SELF,
        'INTEGRATED_CNC_SCHEMA.SHAPE_ASPECT_RELATIONSHIP.' +
        'RELATING_SHAPE_ASPECT')| (
        'INTEGRATED_CNC_SCHEMA.FEATURE_COMPONENT_RELATIONSHIP' IN
        TYPEOF(sar))| (('INTEGRATED_CNC_SCHEMA.CHAMFER_OFFSET' IN
        TYPEOF(fcr.related_shape_aspect)) AND (
        'INTEGRATED_CNC_SCHEMA.CHAMFER' IN TYPEOF(fcr.
        relating_shape_aspect))) AND (fcr.related_shape_aspect.
        description = 'first offset')) = 1;
    WR3: SIZEOF(QUERY (fcr <* QUERY (sar <* USEDIN(SELF,
        'INTEGRATED_CNC_SCHEMA.SHAPE_ASPECT_RELATIONSHIP.' +
        'RELATING_SHAPE_ASPECT')| (
        'INTEGRATED_CNC_SCHEMA.FEATURE_COMPONENT_RELATIONSHIP' IN
        TYPEOF(sar))| (('INTEGRATED_CNC_SCHEMA.CHAMFER_OFFSET' IN
        TYPEOF(fcr.related_shape_aspect)) AND (
        'INTEGRATED_CNC_SCHEMA.CHAMFER' IN TYPEOF(fcr.
        relating_shape_aspect))) AND (fcr.related_shape_aspect.
        description = 'second offset')) = 1;
END_ENTITY; -- 10303-522: aic_machining_feature

ENTITY chamfer_offset
    SUBTYPE OF (shape_aspect);
WHERE
    WR1: SELF.description IN [ 'first offset', 'second offset' ];
    WR2: SIZEOF(QUERY (pd <* USEDIN(SELF,
        'INTEGRATED_CNC_SCHEMA.PROPERTY_DEFINITION.DEFINITION')| NOT
        (SIZEOF(QUERY (pdr <* USEDIN(pd, 'INTEGRATED_CNC_SCHEMA.' +
        'PROPERTY_DEFINITION_REPRESENTATION.DEFINITION')| (
        'INTEGRATED_CNC_SCHEMA.' +
        'SHAPE_REPRESENTATION_WITH_PARAMETERS' IN TYPEOF(pdr.

```



```

used_representation)))) = 1))) = 0;
WR3: SIZEOF(QUERY (pd <* USEDIN(SELF,
  'INTEGRATED_CNC_SCHEMA.PROPERTY_DEFINITION.DEFINITION') | NOT
  (SIZEOF(QUERY (impl_rep <* QUERY (pdr <* USEDIN(pd,
  'INTEGRATED_CNC_SCHEMA.' +
  'PROPERTY_DEFINITION_REPRESENTATION.DEFINITION') | (
  'INTEGRATED_CNC_SCHEMA.' +
  'SHAPE_REPRESENTATION_WITH_PARAMETERS' IN TYPEOF(pdr.
  used_representation))) | NOT (SIZEOF(impl_rep.
  used_representation.items) = 1))) = 0))) = 0;
WR4: NOT (SELF.description = 'first offset') OR (SIZEOF(QUERY (pd <*
  USEDIN(SELF,
  'INTEGRATED_CNC_SCHEMA.PROPERTY_DEFINITION.DEFINITION') | NOT
  (SIZEOF(QUERY (impl_rep <* QUERY (pdr <* USEDIN(pd,
  'INTEGRATED_CNC_SCHEMA.' +
  'PROPERTY_DEFINITION_REPRESENTATION.DEFINITION') | (
  'INTEGRATED_CNC_SCHEMA.' +
  'SHAPE_REPRESENTATION_WITH_PARAMETERS' IN TYPEOF(pdr.
  used_representation))) | NOT (SIZEOF(QUERY (it <* impl_rep.
  used_representation.items | (SIZEOF([
  'INTEGRATED_CNC_SCHEMA.MEASURE_REPRESENTATION_ITEM',
  'INTEGRATED_CNC_SCHEMA.LENGTH_MEASURE_WITH_UNIT' ] * TYPEOF(
  it)) = 2) AND (it.name = 'offset amount')) = 1))) = 0))) = 0
  );
WR5: NOT (SELF.description = 'first offset') OR (SIZEOF(QUERY (pd <*
  USEDIN(SELF,
  'INTEGRATED_CNC_SCHEMA.PROPERTY_DEFINITION.DEFINITION') | NOT
  (SIZEOF(QUERY (pdr <* USEDIN(pd, 'INTEGRATED_CNC_SCHEMA.' +
  'PROPERTY_DEFINITION_REPRESENTATION.DEFINITION') | (
  'INTEGRATED_CNC_SCHEMA.FACE_SHAPE_REPRESENTATION' IN TYPEOF(
  pdr.used_representation)) AND (pdr.used_representation.name =
  'first face shape')) <= 1))) = 0);
WR6: NOT (SELF.description = 'second offset') OR (SIZEOF(QUERY (pd <*
  USEDIN(SELF,
  'INTEGRATED_CNC_SCHEMA.PROPERTY_DEFINITION.DEFINITION') | NOT
  (SIZEOF(QUERY (impl_rep <* QUERY (pdr <* USEDIN(pd,
  'INTEGRATED_CNC_SCHEMA.' +
  'PROPERTY_DEFINITION_REPRESENTATION.DEFINITION') | (
  'INTEGRATED_CNC_SCHEMA.' +
  'SHAPE_REPRESENTATION_WITH_PARAMETERS' IN TYPEOF(pdr.
  used_representation))) | NOT (SIZEOF(QUERY (it <* impl_rep.
  used_representation.items | (SIZEOF([
  'INTEGRATED_CNC_SCHEMA.MEASURE_REPRESENTATION_ITEM',
  'INTEGRATED_CNC_SCHEMA.LENGTH_MEASURE_WITH_UNIT' ] * TYPEOF(
  it)) = 2) AND (it.name = 'offset amount') OR (SIZEOF([
  'INTEGRATED_CNC_SCHEMA.MEASURE_REPRESENTATION_ITEM',
  'INTEGRATED_CNC_SCHEMA.PLANE_ANGLE_MEASURE_WITH_UNIT' ] *
  TYPEOF(it)) = 2) AND (it.name = 'offset angle')) = 1))) = 0
  )) = 0);
WR7: NOT (SELF.description = 'second offset') OR (SIZEOF(QUERY (pd <*
  USEDIN(SELF,
  'INTEGRATED_CNC_SCHEMA.PROPERTY_DEFINITION.DEFINITION') | NOT
  (SIZEOF(QUERY (pdr <* USEDIN(pd, 'INTEGRATED_CNC_SCHEMA.' +
  'PROPERTY_DEFINITION_REPRESENTATION.DEFINITION') | (

```

```

        'INTEGRATED_CNC_SCHEMA.FACE_SHAPE_REPRESENTATION' IN TYPEOF(
        pdr.used_representation)) AND (pdr.used_representation.name =
        'second face shape')) (<= 1)) = 0);
WR8: SIZEOF(QUERY (sdr <* QUERY (sar <* USEDIN(SELF,
        'INTEGRATED_CNC_SCHEMA.SHAPE_ASPECT_RELATIONSHIP.' +
        'RELATED_SHAPE_ASPECT')| ('INTEGRATED_CNC_SCHEMA.' +
        'FEATURE_COMPONENT_RELATIONSHIP' IN TYPEOF(sar)))| (
        'INTEGRATED_CNC_SCHEMA.CHAMFER' IN TYPEOF(sdr.
        relating_shape_aspect)) AND (
        'INTEGRATED_CNC_SCHEMA.CHAMFER_OFFSET' IN TYPEOF(sdr.
        related_shape_aspect)))) = 1;
END_ENTITY; -- 10303-522: aic_machining_feature

ENTITY characterized_object;
    name      : label;
    description : OPTIONAL text;
END_ENTITY; -- 10303-41: product_property_definition_schema

ENTITY circle
    SUBTYPE OF (conic);
    radius : positive_length_measure;
END_ENTITY; -- 10303-42: geometry_schema

ENTITY circular_closed_profile
    SUBTYPE OF (shape_aspect);
    WHERE
        WR1: 'INTEGRATED_CNC_SCHEMA.FEATURE_COMPONENT_DEFINITION' IN TYPEOF(
            SELF.of_shape.definition);
        WR2: SIZEOF(QUERY (pd <* USEDIN(SELF,
            'INTEGRATED_CNC_SCHEMA.PROPERTY_DEFINITION.DEFINITION')| NOT
            (SIZEOF(QUERY (pdr <* USEDIN(pd, 'INTEGRATED_CNC_SCHEMA.' +
            'PROPERTY_DEFINITION_REPRESENTATION.DEFINITION')| (
            'INTEGRATED_CNC_SCHEMA.' +
            'SHAPE_REPRESENTATION_WITH_PARAMETERS' IN TYPEOF(pdr.
            used_representation)))) = 1))) = 0;
        WR3: SIZEOF(QUERY (pd <* USEDIN(SELF,
            'INTEGRATED_CNC_SCHEMA.PROPERTY_DEFINITION.DEFINITION')| NOT
            (SIZEOF(QUERY (impl_rep <* QUERY (pdr <* USEDIN(pd,
            'INTEGRATED_CNC_SCHEMA.' +
            'PROPERTY_DEFINITION_REPRESENTATION.DEFINITION')| (
            'INTEGRATED_CNC_SCHEMA.' +
            'SHAPE_REPRESENTATION_WITH_PARAMETERS' IN TYPEOF(pdr.
            used_representation)))| NOT (SIZEOF(impl_rep.
            used_representation.items) = 2))) = 0))) = 0;
        WR4: SIZEOF(QUERY (pd <* USEDIN(SELF,
            'INTEGRATED_CNC_SCHEMA.PROPERTY_DEFINITION.DEFINITION')| NOT
            (SIZEOF(QUERY (impl_rep <* QUERY (pdr <* USEDIN(pd,
            'INTEGRATED_CNC_SCHEMA.' +
            'PROPERTY_DEFINITION_REPRESENTATION.DEFINITION')| (
            'INTEGRATED_CNC_SCHEMA.' +
            'SHAPE_REPRESENTATION_WITH_PARAMETERS' IN TYPEOF(pdr.
            used_representation)))| NOT (SIZEOF(QUERY (it <* impl_rep.
            used_representation.items| ('INTEGRATED_CNC_SCHEMA.PLACEMENT'
            IN TYPEOF(it)) AND (it.name = 'orientation')) = 1))) = 0)))

```

```

= 0;
WR5: SIZEOF(QUERY (pd <* USEDIN(SELf,
  'INTEGRATED_CNC_SCHEMA.PROPERTY_DEFINITION.DEFINITION') | NOT
  (SIZEOF(QUERY (impl_rep <* QUERY (pdr <* USEDIN(pd,
  'INTEGRATED_CNC_SCHEMA.' +
  'PROPERTY_DEFINITION_REPRESENTATION.DEFINITION') | (
  'INTEGRATED_CNC_SCHEMA.' +
  'SHAPE_REPRESENTATION_WITH_PARAMETERS' IN TYPEOF(pdr.
  used_representation))) | NOT (SIZEOF(QUERY (it <* impl_rep.
  used_representation.items | (SIZEOF([
  'INTEGRATED_CNC_SCHEMA.MEASURE_REPRESENTATION_ITEM',
  'INTEGRATED_CNC_SCHEMA.LENGTH_MEASURE_WITH_UNIT' ] * TYPEOF(
  it)) = 2) AND (it.name = 'diameter')))) = 1))) = 0))) = 0;
END_ENTITY; -- 10303-522: aic_machining_feature

```

ENTITY circular\_pattern

SUBTYPE OF (replicate\_feature);

WHERE

```

WR1: SIZEOF(QUERY (pds <* QUERY (pd <* USEDIN(SELf,
  'INTEGRATED_CNC_SCHEMA.PROPERTY_DEFINITION.DEFINITION') | (
  'INTEGRATED_CNC_SCHEMA.PRODUCT_DEFINITION_SHAPE' IN TYPEOF(pd
  ))) | NOT (SIZEOF(QUERY (sa_occ <* USEDIN(pds,
  'INTEGRATED_CNC_SCHEMA.SHAPE_ASPECT.OF_SHAPE') | (SIZEOF(QUERY
  (sdr <* QUERY (sar <* USEDIN(sa_occ,
  'INTEGRATED_CNC_SCHEMA.SHAPE_ASPECT_RELATIONSHIP.' +
  'RELATING_SHAPE_ASPECT') | (
  'INTEGRATED_CNC_SCHEMA.FEATURE_COMPONENT_RELATIONSHIP' IN
  TYPEOF(sar))) | ('INTEGRATED_CNC_SCHEMA.SHAPE_ASPECT' IN
  TYPEOF(sdr.related_shape_aspect)))) = 1))) <= 3))) = 0;
WR2: SIZEOF(QUERY (pd <* USEDIN(SELf,
  'INTEGRATED_CNC_SCHEMA.PROPERTY_DEFINITION.DEFINITION') | NOT
  (SIZEOF(QUERY (pdr <* USEDIN(pd, 'INTEGRATED_CNC_SCHEMA.' +
  'PROPERTY_DEFINITION_REPRESENTATION.DEFINITION') | (
  'INTEGRATED_CNC_SCHEMA.' +
  'SHAPE_REPRESENTATION_WITH_PARAMETERS' IN TYPEOF(pdr.
  used_representation)))) = 1))) = 0;
WR3: SIZEOF(QUERY (pd <* USEDIN(SELf,
  'INTEGRATED_CNC_SCHEMA.PROPERTY_DEFINITION.DEFINITION') | NOT
  (SIZEOF(QUERY (impl_rep <* QUERY (pdr <* USEDIN(pd,
  'INTEGRATED_CNC_SCHEMA.' +
  'PROPERTY_DEFINITION_REPRESENTATION.DEFINITION') | (
  'INTEGRATED_CNC_SCHEMA.' +
  'SHAPE_REPRESENTATION_WITH_PARAMETERS' IN TYPEOF(pdr.
  used_representation))) | NOT ((SIZEOF(impl_rep.
  used_representation.items) >= 3) AND (SIZEOF(impl_rep.
  used_representation.items) <= 5)))) = 0))) = 0;
WR4: SIZEOF(QUERY (pd <* USEDIN(SELf,
  'INTEGRATED_CNC_SCHEMA.PROPERTY_DEFINITION.DEFINITION') | NOT
  (SIZEOF(QUERY (impl_rep <* QUERY (pdr <* USEDIN(pd,
  'INTEGRATED_CNC_SCHEMA.' +
  'PROPERTY_DEFINITION_REPRESENTATION.DEFINITION') | (
  'INTEGRATED_CNC_SCHEMA.' +
  'SHAPE_REPRESENTATION_WITH_PARAMETERS' IN TYPEOF(pdr.
  used_representation))) | NOT (SIZEOF(QUERY (it <* impl_rep.

```

```

used_representation.items| (SIZEOF([
'INTEGRATED_CNC_SCHEMA.MEASURE_REPRESENTATION_ITEM',
'INTEGRATED_CNC_SCHEMA.LENGTH_MEASURE_WITH_UNIT' ] * TYPEOF(
it)) = 2) AND (it.name = 'diameter')) <= 1))) = 0));
WR5: SIZEOF(QUERY (pd <* USEDIN(SELF,
'INTEGRATED_CNC_SCHEMA.PROPERTY_DEFINITION.DEFINITION')| NOT
(SIZEOF(QUERY (impl_rep <* QUERY (pdr <* USEDIN(pd,
'INTEGRATED_CNC_SCHEMA.' +
'PROPERTY_DEFINITION_REPRESENTATION.DEFINITION')| (
'INTEGRATED_CNC_SCHEMA.' +
'SHAPE_REPRESENTATION_WITH_PARAMETERS' IN TYPEOF(pdr.
used_representation)))| NOT (SIZEOF(QUERY (it <* impl_rep.
used_representation.items| (SIZEOF([
'INTEGRATED_CNC_SCHEMA.MEASURE_REPRESENTATION_ITEM',
'INTEGRATED_CNC_SCHEMA.PLANE_ANGLE_MEASURE_WITH_UNIT' ] *
TYPEOF(it)) = 2) AND (it.name = 'base feature rotation')) <=
1))) = 0))) = 0;
WR6: SIZEOF(QUERY (pd <* USEDIN(SELF,
'INTEGRATED_CNC_SCHEMA.PROPERTY_DEFINITION.DEFINITION')| NOT
(SIZEOF(QUERY (impl_rep <* QUERY (pdr <* USEDIN(pd,
'INTEGRATED_CNC_SCHEMA.' +
'PROPERTY_DEFINITION_REPRESENTATION.DEFINITION')| (
'INTEGRATED_CNC_SCHEMA.' +
'SHAPE_REPRESENTATION_WITH_PARAMETERS' IN TYPEOF(pdr.
used_representation)))| NOT (SIZEOF(QUERY (it <* impl_rep.
used_representation.items| ((
'INTEGRATED_CNC_SCHEMA.MEASURE_REPRESENTATION_ITEM' IN TYPEOF
(it)) AND ('INTEGRATED_CNC_SCHEMA.COUNT_MEASURE' IN TYPEOF(it
\measure_with_unit.value_component))) AND (it.name =
'number of features')))) = 1))) = 0))) = 0;
WR7: SIZEOF(QUERY (pd <* USEDIN(SELF,
'INTEGRATED_CNC_SCHEMA.PROPERTY_DEFINITION.DEFINITION')| NOT
(SIZEOF(QUERY (impl_rep <* QUERY (pdr <* USEDIN(pd,
'INTEGRATED_CNC_SCHEMA.' +
'PROPERTY_DEFINITION_REPRESENTATION.DEFINITION')| (
'INTEGRATED_CNC_SCHEMA.' +
'SHAPE_REPRESENTATION_WITH_PARAMETERS' IN TYPEOF(pdr.
used_representation)))| NOT (SIZEOF(QUERY (it <* impl_rep.
used_representation.items| (SIZEOF([
'INTEGRATED_CNC_SCHEMA.MEASURE_REPRESENTATION_ITEM',
'INTEGRATED_CNC_SCHEMA.PLANE_ANGLE_MEASURE_WITH_UNIT' ] *
TYPEOF(it)) = 2) AND (it.name = 'angular spacing')) = 1))) =
0))) = 0;
WR8: SIZEOF(QUERY (pd <* USEDIN(SELF,
'INTEGRATED_CNC_SCHEMA.PROPERTY_DEFINITION.DEFINITION')| NOT
(SIZEOF(QUERY (impl_rep <* QUERY (pdr <* USEDIN(pd,
'INTEGRATED_CNC_SCHEMA.' +
'PROPERTY_DEFINITION_REPRESENTATION.DEFINITION')| (
'INTEGRATED_CNC_SCHEMA.' +
'SHAPE_REPRESENTATION_WITH_PARAMETERS' IN TYPEOF(pdr.
used_representation)))| NOT (SIZEOF(QUERY (it <* impl_rep.
used_representation.items| ('INTEGRATED_CNC_SCHEMA.PLACEMENT'
IN TYPEOF(it)) AND (it.name = 'orientation')) = 1))) = 0)))
= 0;

```

```

END_ENTITY; -- 10303-522: aic_machining_feature

ENTITY circular_runout_tolerance
  SUBTYPE OF (geometric_tolerance_with_datum_reference);
  WHERE
    WR1: SIZEOF(SELF\geometric_tolerance_with_datum_reference.datum_system)
      <= 2;
END_ENTITY; -- 10303-519: aic_geometric_tolerances

ENTITY class
  SUBTYPE OF (group);
END_ENTITY; -- 10303-238: integrated_cnc_schema

ENTITY classification_assignment
  ABSTRACT SUPERTYPE;
  assigned_class : group;
  role           : classification_role;
END_ENTITY; -- 10303-41: management_resources_schema

ENTITY classification_role;
  name          : label;
  description   : OPTIONAL text;
END_ENTITY; -- 10303-41: management_resources_schema

ENTITY closed_path_profile
  SUBTYPE OF (shape_aspect);
  WHERE
    WR1: 'INTEGRATED_CNC_SCHEMA.FEATURE_COMPONENT_DEFINITION' IN TYPEOF(
      SELF.of_shape.definition);
    WR2: SIZEOF(QUERY (pd <* USEDIN(SELF,
      'INTEGRATED_CNC_SCHEMA.PROPERTY_DEFINITION.' + 'DEFINITION') |
      NOT (SIZEOF(QUERY (pdr <* USEDIN(pd,
      'INTEGRATED_CNC_SCHEMA.' +
      'PROPERTY_DEFINITION_REPRESENTATION.DEFINITION') | (
      'INTEGRATED_CNC_SCHEMA.' +
      'SHAPE_REPRESENTATION_WITH_PARAMETERS' IN TYPEOF(pdr.
      used_representation)))) = 1))) = 0;
    WR3: SIZEOF(QUERY (pd <* USEDIN(SELF,
      'INTEGRATED_CNC_SCHEMA.PROPERTY_DEFINITION.DEFINITION') | NOT
      (SIZEOF(QUERY (impl_rep <* QUERY (pdr <* USEDIN(pd,
      'INTEGRATED_CNC_SCHEMA.' +
      'PROPERTY_DEFINITION_REPRESENTATION.DEFINITION') | (
      'INTEGRATED_CNC_SCHEMA.' +
      'SHAPE_REPRESENTATION_WITH_PARAMETERS' IN TYPEOF(pdr.
      used_representation))) | NOT (SIZEOF(impl_rep.
      used_representation.items) = 1))) = 0))) = 0;
    WR4: SIZEOF(QUERY (pd <* USEDIN(SELF,
      'INTEGRATED_CNC_SCHEMA.PROPERTY_DEFINITION.DEFINITION') | NOT
      (SIZEOF(QUERY (impl_rep <* QUERY (pdr <* USEDIN(pd,
      'INTEGRATED_CNC_SCHEMA.' +
      'PROPERTY_DEFINITION_REPRESENTATION.DEFINITION') | (
      'INTEGRATED_CNC_SCHEMA.' +
      'SHAPE_REPRESENTATION_WITH_PARAMETERS' IN TYPEOF(pdr.
      used_representation))) | NOT (SIZEOF(QUERY (it <* impl_rep.

```

```

        used_representation.items| ('INTEGRATED_CNC_SCHEMA.PLACEMENT'
        IN TYPEOF(it)) AND (it.name = 'orientation')) = 1))) = 0)))
        = 0;
    WR5: SIZEOF(QUERY (pd <* USEDIN(SELF,
        'INTEGRATED_CNC_SCHEMA.PROPERTY_DEFINITION.' + 'DEFINITION')|
        NOT (SIZEOF(QUERY (pdr <* USEDIN(pd,
        'INTEGRATED_CNC_SCHEMA.' +
        'PROPERTY_DEFINITION_REPRESENTATION.DEFINITION')| (
        'INTEGRATED_CNC_SCHEMA.PATH_SHAPE_REPRESENTATION' IN TYPEOF(
        pdr.used_representation)))) = 1))) = 0;
END_ENTITY; -- 10303-522: aic_machining_feature

ENTITY closed_shell
    SUBTYPE OF (connected_face_set);
END_ENTITY; -- 10303-42: topology_schema

ENTITY coaxiality_tolerance
    SUBTYPE OF (geometric_tolerance_with_datum_reference);
    WHERE
        WR1: SIZEOF(SELF\geometric_tolerance_with_datum_reference.datum_system)
            <= 2;
END_ENTITY; -- 10303-519: aic_geometric_tolerances

ENTITY common_datum
    SUBTYPE OF (composite_shape_aspect, datum);
    WHERE
        WR1: SIZEOF(SELF.component_relationships) = 2;
        WR2: SIZEOF(QUERY (sar <* SELF.component_relationships| NOT ((
            'INTEGRATED_CNC_SCHEMA.DATUM' IN TYPEOF(sar.
            related_shape_aspect)) AND NOT (
            'INTEGRATED_CNC_SCHEMA.COMMON_DATUM' IN TYPEOF(sar.
            related_shape_aspect)))) = 0;
END_ENTITY; -- 10303-519: aic_geometric_tolerances

ENTITY comparison_equal
    SUBTYPE OF (comparison_expression);
END_ENTITY; -- 13584-20: iso13584_expressions_schema

ENTITY comparison_expression
    ABSTRACT SUPERTYPE OF (ONEOF (comparison_equal,comparison_greater,
        comparison_greater_equal,comparison_less,comparison_less_equal,
        comparison_not_equal))
    SUBTYPE OF (boolean_expression, binary_generic_expression);
    SELF\binary_generic_expression.operands : LIST [2:2] OF expression;
    WHERE
        WR1: (('INTEGRATED_CNC_SCHEMA.NUMERIC_EXPRESSION'
            IN TYPEOF(SELF\binary_generic_expression.operands[1])) AND
            ('INTEGRATED_CNC_SCHEMA.NUMERIC_EXPRESSION'
            IN TYPEOF(SELF\binary_generic_expression.operands[2])))
        OR
        (('INTEGRATED_CNC_SCHEMA.BOOLEAN_EXPRESSION'
            IN TYPEOF(SELF\binary_generic_expression.operands[1])) AND
            ('INTEGRATED_CNC_SCHEMA.BOOLEAN_EXPRESSION'
            IN TYPEOF(SELF\binary_generic_expression.operands[2]))));

```

```

END_ENTITY; -- 13584-20: iso13584_expressions_schema

ENTITY comparison_greater
  SUBTYPE OF (comparison_expression);
END_ENTITY; -- 13584-20: iso13584_expressions_schema

ENTITY comparison_greater_equal
  SUBTYPE OF (comparison_expression);
END_ENTITY; -- 13584-20: iso13584_expressions_schema

ENTITY comparison_less
  SUBTYPE OF (comparison_expression);
END_ENTITY; -- 13584-20: iso13584_expressions_schema

ENTITY comparison_less_equal
  SUBTYPE OF (comparison_expression);
END_ENTITY; -- 13584-20: iso13584_expressions_schema

ENTITY comparison_not_equal
  SUBTYPE OF (comparison_expression);
END_ENTITY; -- 13584-20: iso13584_expressions_schema

ENTITY composite_curve
  SUBTYPE OF (bounded_curve);
  segments          : LIST [1:?] OF composite_curve_segment;
  self_intersect    : LOGICAL;
  DERIVE
    n_segments      : INTEGER := SIZEOF(segments);
    closed_curve    : LOGICAL := segments[n_segments].transition <>
                      discontinuous;
  WHERE
    WR1: NOT closed_curve AND (SIZEOF(QUERY (temp <* segments| (temp.
      transition = discontinuous))) = 1) OR closed_curve AND (
      SIZEOF(QUERY (temp <* segments| (temp.transition =
      discontinuous))) = 0);
END_ENTITY; -- 10303-42: geometry_schema

ENTITY composite_curve_on_surface
  SUPERTYPE OF (boundary_curve)
  SUBTYPE OF (composite_curve);
  DERIVE
    basis_surface : SET [0:2] OF surface := get_basis_surface(SELF);
  WHERE
    WR1: SIZEOF(basis_surface) > 0;
    WR2: constraints_composite_curve_on_surface(SELF);
END_ENTITY; -- 10303-42: geometry_schema

ENTITY composite_curve_segment
  SUBTYPE OF (founded_item);
  transition      : transition_code;
  same_sense      : BOOLEAN;
  parent_curve    : curve;
  INVERSE
    using_curves  : BAG [1:?] OF composite_curve FOR segments;

```

ISO 10303-238:2007(E)

```

WHERE
  WR1: 'INTEGRATED_CNC_SCHEMA.BOUNDED_CURVE' IN TYPEOF(parent_curve);
END_ENTITY; -- 10303-42: geometry_schema

ENTITY composite_hole
  SUBTYPE OF (compound_feature);
  WHERE
    WR1: SELF\characterized_object.description IN [ 'counterbore',
      'countersunk' ];
    WR2: SIZEOF(QUERY (pds <* USEDIN(SELF,
      'INTEGRATED_CNC_SCHEMA.PROPERTY_DEFINITION.DEFINITION')| (
      'INTEGRATED_CNC_SCHEMA.PRODUCT_DEFINITION_SHAPE' IN TYPEOF(
      pds)) AND (SIZEOF(QUERY (csa <* USEDIN(pds,
      'INTEGRATED_CNC_SCHEMA.SHAPE_ASPECT.OF_SHAPE')| (
      'INTEGRATED_CNC_SCHEMA.COMPOSITE_SHAPE_ASPECT' IN TYPEOF(csa)
      ) AND (SIZEOF(QUERY (sar <* csa.component_relationships| (
      'INTEGRATED_CNC_SCHEMA.FEATURE_COMPONENT_RELATIONSHIP' IN
      TYPEOF(sar)) AND ('INTEGRATED_CNC_SCHEMA.ROUND_HOLE' IN
      TYPEOF(sar.related_shape_aspect)))) = 2))) = 1))) = 1;
    WR3: NOT (SELF\characterized_object.description = 'countersunk') OR (
      SIZEOF(QUERY (pds <* USEDIN(SELF,
      'INTEGRATED_CNC_SCHEMA.PROPERTY_DEFINITION.DEFINITION')| (
      'INTEGRATED_CNC_SCHEMA.PRODUCT_DEFINITION_SHAPE' IN TYPEOF(
      pds)) AND (SIZEOF(QUERY (csa <* USEDIN(pds,
      'INTEGRATED_CNC_SCHEMA.SHAPE_ASPECT.OF_SHAPE')| (
      'INTEGRATED_CNC_SCHEMA.COMPOSITE_SHAPE_ASPECT' IN TYPEOF(csa)
      ) AND (SIZEOF(QUERY (sar <* csa.component_relationships| (
      'INTEGRATED_CNC_SCHEMA.ROUND_HOLE' IN TYPEOF(sar.
      related_shape_aspect)) AND NOT (SIZEOF(QUERY (pds <* QUERY (
      pd <* USEDIN(sar.related_shape_aspect,
      'INTEGRATED_CNC_SCHEMA.PROPERTY_DEFINITION.DEFINITION')| (
      'INTEGRATED_CNC_SCHEMA.PRODUCT_DEFINITION_SHAPE' IN TYPEOF(pd
      )))| NOT (SIZEOF(QUERY (sa_occ <* USEDIN(pds,
      'INTEGRATED_CNC_SCHEMA.SHAPE_ASPECT.OF_SHAPE')| (sa_occ.
      description = 'change in diameter occurrence') AND (SIZEOF(
      QUERY (fcr2 <* QUERY (sar2 <* USEDIN(sa_occ,
      'INTEGRATED_CNC_SCHEMA.SHAPE_ASPECT_RELATIONSHIP.RELATING_SHAPE_ASPECT'
      ))| (sar2.description = 'taper usage') AND (
      'INTEGRATED_CNC_SCHEMA.FEATURE_COMPONENT_RELATIONSHIP' IN
      TYPEOF(sar2)))| ('INTEGRATED_CNC_SCHEMA.TAPER' IN TYPEOF(fcr2
      .related_shape_aspect)))) = 1))) = 0))) = 0))) = 1))) = 1)))
      = 1);
END_ENTITY; -- 10303-522: aic_machining_feature

ENTITY composite_shape_aspect
  SUBTYPE OF (shape_aspect);
  INVERSE
    component_relationships : SET [2:?] OF shape_aspect_relationship FOR
      relating_shape_aspect;
END_ENTITY; -- 10303-47: shape_aspect_definition_schema

ENTITY compound_feature
  SUBTYPE OF (feature_definition);

```



WHERE

```

WR1: SIZEOF(QUERY (pds <* USEDIN(SELF,
    'INTEGRATED_CNC_SCHEMA.PROPERTY_DEFINITION.DEFINITION')| (
    'INTEGRATED_CNC_SCHEMA.PRODUCT_DEFINITION_SHAPE' IN TYPEOF(
pds)) AND (SIZEOF(QUERY (csa <* USEDIN(pds,
    'INTEGRATED_CNC_SCHEMA.SHAPE_ASPECT.OF_SHAPE')| (csa.name =
    'compound feature in solid') AND (
    'INTEGRATED_CNC_SCHEMA.COMPOSITE_SHAPE_ASPECT' IN TYPEOF(csa)
))) = 1))) = 1;
WR2: SIZEOF(QUERY (pds <* USEDIN(SELF,
    'INTEGRATED_CNC_SCHEMA.PROPERTY_DEFINITION.DEFINITION')| (
    'INTEGRATED_CNC_SCHEMA.PRODUCT_DEFINITION_SHAPE' IN TYPEOF(
pds)) AND (SIZEOF(QUERY (csa <* USEDIN(pds,
    'INTEGRATED_CNC_SCHEMA.SHAPE_ASPECT.OF_SHAPE')| (
    'INTEGRATED_CNC_SCHEMA.COMPOSITE_SHAPE_ASPECT' IN TYPEOF(csa)
))) = 1))) = 1;
WR3: SIZEOF(QUERY (pds <* USEDIN(SELF,
    'INTEGRATED_CNC_SCHEMA.PROPERTY_DEFINITION.DEFINITION')| (
    'INTEGRATED_CNC_SCHEMA.PRODUCT_DEFINITION_SHAPE' IN TYPEOF(
pds)) AND (SIZEOF(QUERY (csa <* USEDIN(pds,
    'INTEGRATED_CNC_SCHEMA.SHAPE_ASPECT.OF_SHAPE')| (
    'INTEGRATED_CNC_SCHEMA.COMPOSITE_SHAPE_ASPECT' IN TYPEOF(csa)
) AND (SIZEOF(QUERY (fcr <* csa.component_relationships| NOT
('INTEGRATED_CNC_SCHEMA.FEATURE_COMPONENT_RELATIONSHIP' IN
TYPEOF(fcr)))) = 0))) = 1))) = 1;
WR4: SIZEOF(QUERY (pds <* USEDIN(SELF,
    'INTEGRATED_CNC_SCHEMA.PROPERTY_DEFINITION.DEFINITION')| (
    'INTEGRATED_CNC_SCHEMA.PRODUCT_DEFINITION_SHAPE' IN TYPEOF(
pds)) AND (SIZEOF(QUERY (csa <* USEDIN(pds,
    'INTEGRATED_CNC_SCHEMA.SHAPE_ASPECT.OF_SHAPE')| (
    'INTEGRATED_CNC_SCHEMA.COMPOSITE_SHAPE_ASPECT' IN TYPEOF(csa)
))) = 1))) = 1;
WR5: SIZEOF(QUERY (pds <* USEDIN(SELF,
    'INTEGRATED_CNC_SCHEMA.PROPERTY_DEFINITION.DEFINITION')| (
    'INTEGRATED_CNC_SCHEMA.PRODUCT_DEFINITION_SHAPE' IN TYPEOF(
pds)) AND (SIZEOF(QUERY (csa <* USEDIN(pds,
    'INTEGRATED_CNC_SCHEMA.SHAPE_ASPECT.OF_SHAPE')| (
    'INTEGRATED_CNC_SCHEMA.COMPOSITE_SHAPE_ASPECT' IN TYPEOF(csa)
) AND (SIZEOF(QUERY (sar <* csa.component_relationships| (
    'INTEGRATED_CNC_SCHEMA.THREAD' IN TYPEOF(sar.
related_shape_aspect)))) = 0))) = 1))) = 1;
WR6: SIZEOF(QUERY (pds <* USEDIN(SELF,
    'INTEGRATED_CNC_SCHEMA.PROPERTY_DEFINITION.DEFINITION')| (
    'INTEGRATED_CNC_SCHEMA.PRODUCT_DEFINITION_SHAPE' IN TYPEOF(
pds)) AND (SIZEOF(QUERY (csa <* USEDIN(pds,
    'INTEGRATED_CNC_SCHEMA.SHAPE_ASPECT.OF_SHAPE')| (
    'INTEGRATED_CNC_SCHEMA.COMPOSITE_SHAPE_ASPECT' IN TYPEOF(csa)
) AND (SIZEOF(QUERY (sar <* csa.component_relationships| (
    'INTEGRATED_CNC_SCHEMA.COMPOUND_FEATURE' IN TYPEOF(sar.
related_shape_aspect)) AND (sar.related_shape_aspect\
characterized_object.name <> SELF\characterized_object.name)
) = 0))) = 1))) = 1;
END_ENTITY; -- 10303-522: aic_machining_feature

```

## ISO 10303-238:2007(E)

```
ENTITY compound_representation_item
  SUBTYPE OF (representation_item);
  item_element : compound_item_definition;
END_ENTITY; -- 10303-43: representation_schema

ENTITY concentricity_tolerance
  SUBTYPE OF (geometric_tolerance_with_datum_reference);
  WHERE
    WR1: SIZEOF(SELF\geometric_tolerance_with_datum_reference.datum_system)
          = 1;
END_ENTITY; -- 10303-519: aic_geometric_tolerances

ENTITY concurrent_action_method
  SUBTYPE OF (action_method_relationship);
END_ENTITY; -- 10303-49: method_definition_schema

ENTITY conic
  SUPERTYPE OF (ONEOF(circle, ellipse, hyperbola, parabola))
  SUBTYPE OF (curve);
  position : axis2_placement;
END_ENTITY; -- 10303-42: geometry_schema

ENTITY conical_surface
  SUBTYPE OF (elementary_surface);
  radius      : length_measure;
  semi_angle  : plane_angle_measure;
  WHERE
    WR1: radius >= 0.0;
END_ENTITY; -- 10303-238: integrated_cnc_schema

ENTITY connected_edge_set
  SUBTYPE OF (topological_representation_item);
  ces_edges : SET [1:?] OF edge;
END_ENTITY; -- 10303-42: topology_schema

ENTITY connected_face_set
  SUPERTYPE OF (ONEOF(closed_shell, open_shell))
  SUBTYPE OF (topological_representation_item);
  cfs_faces : SET [1:?] OF face;
END_ENTITY; -- 10303-42: topology_schema

ENTITY context_dependent_shape_representation;
  representation_relation      : shape_representation_relationship;
  represented_product_relation : product_definition_shape;
  DERIVE
    description : text := get_description_value(SELF);
    name        : label := get_name_value(SELF);
  WHERE
    WR1: 'INTEGRATED_CNC_SCHEMA.PRODUCT_DEFINITION_RELATIONSHIP' IN TYPEOF(
          SELF.represented_product_relation.definition);
    WR2: SIZEOF(USEDIN(SELF, 'INTEGRATED_CNC_SCHEMA.' +
          'DESCRIPTION_ATTRIBUTE.DESCRIBED_ITEM')) <= 1;
    WR3: SIZEOF(USEDIN(SELF, 'INTEGRATED_CNC_SCHEMA.' +
          'NAME_ATTRIBUTE.NAMED_ITEM')) <= 1;
```

```

END_ENTITY; -- 10303-41: product_property_representation_schema

ENTITY context_dependent_unit
  SUBTYPE OF (named_unit);
  name : label;
END_ENTITY; -- 10303-41: measure_schema

ENTITY contouring_turning_operation
  SUBTYPE OF (turning_type_operation);
  WHERE
  WR1: (SELF.description IN ['roughing','finishing']);

  WR2: (verify_optional_action_property (SELF, 'allowance')) AND
        (verify_length_measure_action_property (SELF, 'allowance'));

  WR3: NOT (SELF.description = 'roughing') OR
        (verify_required_action_property (SELF, 'allowance'));
END_ENTITY; -- 10303-238: integrated_cnc_schema

ENTITY conversion_based_unit
  SUBTYPE OF (named_unit);
  name : label;
  conversion_factor : measure_with_unit;
END_ENTITY; -- 10303-41: measure_schema

ENTITY coordinated_universal_time_offset;
  hour_offset : INTEGER;
  minute_offset : OPTIONAL INTEGER;
  sense : ahead_or_behind;
  DERIVE
  actual_minute_offset : INTEGER := NVL(minute_offset, 0);
  WHERE
  WR1: (0 <= hour_offset) AND (hour_offset < 24);
  WR2: (0 <= actual_minute_offset) AND (actual_minute_offset <= 59);
  WR3: NOT ((hour_offset <> 0) OR (actual_minute_offset <> 0)) AND (
    sense = exact));
END_ENTITY; -- 10303-41: date_time_schema

ENTITY curve
  SUPERTYPE OF (ONEOF(line, conic, pcurve, surface_curve, offset_curve_3d,
    curve_replica))
  SUBTYPE OF (geometric_representation_item);
END_ENTITY; -- 10303-42: geometry_schema

ENTITY curve_bounded_surface
  SUBTYPE OF (bounded_surface);
  basis_surface : surface;
  boundaries : SET [1:?] OF boundary_curve;
  implicit_outer : BOOLEAN;
  WHERE
  WR1: NOT implicit_outer OR (SIZEOF(QUERY (temp <* boundaries| (
    'INTEGRATED_CNC_SCHEMA.OUTER_BOUNDARY_CURVE' IN TYPEOF(temp))
  )) = 0);
  WR2: NOT implicit_outer OR ('INTEGRATED_CNC_SCHEMA.BOUNDED_SURFACE' IN

```

```

        TYPEOF(basis_surface));
    WR3: SIZEOF(QUERY (temp <* boundaries| (
        'INTEGRATED_CNC_SCHEMA.OUTER_BOUNDARY_CURVE' IN TYPEOF(temp))
    )) <= 1;
    WR4: SIZEOF(QUERY (temp <* boundaries| (temp\composite_curve_on_surface
        .basis_surface[1] <> SELF.basis_surface))) = 0;
END_ENTITY; -- 10303-42: geometry_schema

ENTITY curve_replica
    SUBTYPE OF (curve);
    parent_curve    : curve;
    transformation  : cartesian_transformation_operator;
    WHERE
        WR1: transformation.dim = parent_curve.dim;
        WR2: acyclic_curve_replica(SELF, parent_curve);
END_ENTITY; -- 10303-42: geometry_schema

ENTITY cylindrical_shape_representation
    SUBTYPE OF (shape_representation_with_parameters);
    WHERE
        WR1: SIZEOF(SELF.items) = 3;
        WR2: SIZEOF(QUERY (it <* SELF.items| ('INTEGRATED_CNC_SCHEMA.PLACEMENT'
            IN TYPEOF(it)) AND (it.name = 'orientation')))) = 1;
        WR3: SIZEOF(QUERY (it <* SELF.items| (SIZEOF([
            'INTEGRATED_CNC_SCHEMA.MEASURE_REPRESENTATION_ITEM',
            'INTEGRATED_CNC_SCHEMA.LENGTH_MEASURE_WITH_UNIT' ] * TYPEOF(
            it)) = 2) AND (it.name = 'length')))) = 1;
        WR4: SIZEOF(QUERY (it <* SELF.items| (SIZEOF([
            'INTEGRATED_CNC_SCHEMA.MEASURE_REPRESENTATION_ITEM',
            'INTEGRATED_CNC_SCHEMA.LENGTH_MEASURE_WITH_UNIT' ] * TYPEOF(
            it)) = 2) AND (it.name = 'diameter')))) = 1;
END_ENTITY; -- 10303-238: integrated_cnc_schema

ENTITY cylindrical_surface
    SUBTYPE OF (elementary_surface);
    radius : positive_length_measure;
END_ENTITY; -- 10303-42: geometry_schema

ENTITY cylindricity_tolerance
    SUBTYPE OF (geometric_tolerance);
    WHERE
        WR1: NOT ('INTEGRATED_CNC_SCHEMA.' +
            'GEOMETRIC_TOLERANCE_WITH_DATUM_REFERENCE' IN TYPEOF(SELF));
END_ENTITY; -- 10303-519: aic_geometric_tolerances

ENTITY data_environment;
    name      : label;
    description : text;
    elements  : SET [1:?] OF property_definition_representation;
END_ENTITY; -- 10303-45: material_property_representation_schema

ENTITY date
    SUPERTYPE OF (ONEOF(calendar_date, ordinal_date,
        week_of_year_and_day_date));

```

```

    year_component : year_number;
END_ENTITY; -- 10303-41: date_time_schema

ENTITY date_and_time;
    date_component : date;
    time_component : local_time;
END_ENTITY; -- 10303-41: date_time_schema

ENTITY date_and_time_assignment
    ABSTRACT SUPERTYPE;
    assigned_date_and_time : date_and_time;
    role : date_time_role;
END_ENTITY; -- 10303-41: management_resources_schema

ENTITY date_assignment
    ABSTRACT SUPERTYPE;
    assigned_date : date;
    role : date_role;
END_ENTITY; -- 10303-41: management_resources_schema

ENTITY date_role;
    name : label;
    DERIVE
        description : text := get_description_value(SELF);
    WHERE
        WR1: SIZEOF(USEDIN(SELF, 'INTEGRATED_CNC_SCHEMA.' +
            'DESCRIPTION_ATTRIBUTE.DESCRIBED_ITEM')) <= 1;
END_ENTITY; -- 10303-41: date_time_schema

ENTITY date_time_role;
    name : label;
    DERIVE
        description : text := get_description_value(SELF);
    WHERE
        WR1: SIZEOF(USEDIN(SELF, 'INTEGRATED_CNC_SCHEMA.' +
            'DESCRIPTION_ATTRIBUTE.DESCRIBED_ITEM')) <= 1;
END_ENTITY; -- 10303-41: date_time_schema

ENTITY datum
    SUBTYPE OF (shape_aspect);
    identification : identifier;
    INVERSE
        established_by_relationships : SET [1:?] OF shape_aspect_relationship
            FOR related_shape_aspect;
    WHERE
        WR1: SIZEOF(QUERY (x <* SELF\datum.established_by_relationships| (
            SIZEOF(TYPEOF(x\shape_aspect_relationship.
            relating_shape_aspect) * [
            'INTEGRATED_CNC_SCHEMA.DATUM_FEATURE',
            'INTEGRATED_CNC_SCHEMA.DATUM_TARGET' ] ) <> 1))) = 0;
END_ENTITY; -- 10303-47: shape_aspect_definition_schema

ENTITY datum_feature
    SUBTYPE OF (shape_aspect);

```

```

INVERSE
    feature_basis_relationship : shape_aspect_relationship FOR
        relating_shape_aspect;

WHERE
    WR1: SIZEOF(QUERY (sar <* bag_to_set(USEDIN(SELF,
        'INTEGRATED_CNC_SCHEMA.SHAPE_ASPECT_RELATIONSHIP.' +
        'RELATING_SHAPE_ASPECT'))| NOT ('INTEGRATED_CNC_SCHEMA.DATUM'
        IN TYPEOF(sar\shape_aspect_relationship.related_shape_aspect
        )))) = 0;
    WR2: SELF\shape_aspect.product_definitional = TRUE;
END_ENTITY; -- 10303-47: shape_aspect_definition_schema

ENTITY datum_reference;
    precedence          : INTEGER;
    referenced_datum    : datum;
WHERE
    WR1: precedence > 0;
END_ENTITY; -- 10303-47: shape_aspect_definition_schema

ENTITY datum_target
    SUBTYPE OF (shape_aspect);
    target_id : identifier;
INVERSE
    target_basis_relationship : shape_aspect_relationship FOR
        relating_shape_aspect;
WHERE
    WR1: SIZEOF(QUERY (sar <* bag_to_set(USEDIN(SELF,
        'INTEGRATED_CNC_SCHEMA.SHAPE_ASPECT_RELATIONSHIP.' +
        'RELATING_SHAPE_ASPECT'))| NOT ('INTEGRATED_CNC_SCHEMA.DATUM'
        IN TYPEOF(sar\shape_aspect_relationship.related_shape_aspect
        )))) = 0;
    WR2: SELF\shape_aspect.product_definitional = TRUE;
END_ENTITY; -- 10303-47: shape_aspect_definition_schema

ENTITY definitional_representation
    SUBTYPE OF (representation);
WHERE
    WR1: 'INTEGRATED_CNC_SCHEMA.PARAMETRIC_REPRESENTATION_CONTEXT' IN
        TYPEOF(SELF\representation.context_of_items);
END_ENTITY; -- 10303-43: representation_schema

ENTITY degenerate_pcurve
    SUBTYPE OF (point);
    basis_surface      : surface;
    reference_to_curve : definitional_representation;
WHERE
    WR1: SIZEOF(reference_to_curve\representation.items) = 1;
    WR2: 'INTEGRATED_CNC_SCHEMA.CURVE' IN TYPEOF(reference_to_curve\
        representation.items[1]);
    WR3: reference_to_curve\representation.items[1]\
        geometric_representation_item.dim = 2;
END_ENTITY; -- 10303-42: geometry_schema

ENTITY degenerate_toroidal_surface

```

```

SUBTYPE OF (toroidal_surface);
  select_outer : BOOLEAN;
WHERE
  WR1: major_radius < minor_radius;
END_ENTITY; -- 10303-42: geometry_schema

ENTITY derived_shape_aspect
  SUPERTYPE OF (ONEOF(apex, centre_of_symmetry, geometric_alignment,
    geometric_intersection, parallel_offset, perpendicular_to, extension,
    tangent))
  SUBTYPE OF (shape_aspect);
  INVERSE
    deriving_relationships : SET [1:?] OF shape_aspect_relationship FOR
      relating_shape_aspect;
  WHERE
    WR1: SIZEOF(QUERY (dr <* SELF\derived_shape_aspect.
      deriving_relationships| NOT ('INTEGRATED_CNC_SCHEMA.' +
        'SHAPE_ASPECT_DERIVING_RELATIONSHIP' IN TYPEOF(dr)))) = 0;
END_ENTITY; -- 10303-47: shape_aspect_definition_schema

ENTITY derived_unit;
  elements : SET [1:?] OF derived_unit_element;
  DERIVE
    name : label := get_name_value(SELF);
  WHERE
    WR1: (SIZEOF(elements) > 1) OR (SIZEOF(elements) = 1) AND (elements[1].
      exponent <> 1.0);
    WR2: SIZEOF(USEDIN(SELF, 'INTEGRATED_CNC_SCHEMA.' +
      'NAME_ATTRIBUTE.NAMED_ITEM')) <= 1;
END_ENTITY; -- 10303-41: measure_schema

ENTITY derived_unit_element;
  unit : named_unit;
  exponent : REAL;
END_ENTITY; -- 10303-41: measure_schema

ENTITY description_attribute;
  attribute_value : text;
  described_item : description_attribute_select;
END_ENTITY; -- 10303-41: basic_attribute_schema

ENTITY descriptive_representation_item
  SUBTYPE OF (representation_item);
  description : text;
END_ENTITY; -- 10303-45: qualified_measure_schema

ENTITY dimension_related_tolerance_zone_element;
  related_dimension : dimensional_location;
  related_element : tolerance_zone_definition;
END_ENTITY; -- 10303-47: shape_tolerance_schema

ENTITY dimensional_characteristic_representation;
  dimension : dimensional_characteristic;
  representation : shape_dimension_representation;

```

## ISO 10303-238:2007(E)

```
END_ENTITY; -- 10303-47: shape_dimension_schema

ENTITY dimensional_exponents;
    length_exponent          : REAL;
    mass_exponent            : REAL;
    time_exponent            : REAL;
    electric_current_exponent : REAL;
    thermodynamic_temperature_exponent : REAL;
    amount_of_substance_exponent : REAL;
    luminous_intensity_exponent : REAL;
END_ENTITY; -- 10303-41: measure_schema

ENTITY dimensional_location
    SUPERTYPE OF (ONEOF(angular_location, dimensional_location_with_path))
    SUBTYPE OF (shape_aspect_relationship);
END_ENTITY; -- 10303-47: shape_dimension_schema

ENTITY dimensional_location_with_path
    SUBTYPE OF (dimensional_location);
    path : shape_aspect;
END_ENTITY; -- 10303-47: shape_dimension_schema

ENTITY dimensional_size
    SUPERTYPE OF (ONEOF(angular_size, dimensional_size_with_path));
    applies_to : shape_aspect;
    name       : label;
    WHERE
        WR1: applies_to.product_definitional = TRUE;
END_ENTITY; -- 10303-47: shape_dimension_schema

ENTITY dimensional_size_with_path
    SUBTYPE OF (dimensional_size);
    path : shape_aspect;
END_ENTITY; -- 10303-47: shape_dimension_schema

ENTITY directed_dimensional_location
    SUBTYPE OF (dimensional_location);
END_ENTITY; -- 10303-238: integrated_cnc_schema

ENTITY direction
    SUBTYPE OF (geometric_representation_item);
    direction_ratios : LIST [2:3] OF REAL;
    WHERE
        WR1: SIZEOF(QUERY (tmp <* direction_ratios| (tmp <> 0.0))) > 0;
END_ENTITY; -- 10303-42: geometry_schema

ENTITY direction_shape_representation
    SUBTYPE OF (shape_representation);
    WHERE
        WR1: SIZEOF(SELF.items) = 1;
        WR2: SIZEOF(QUERY (it <* SELF.items| NOT (
            'INTEGRATED_CNC_SCHEMA.DIRECTION' IN TYPEOF(it)))) = 0;
END_ENTITY; -- 10303-522: aic_machining_feature
```



```

ENTITY document;
    id          : identifier;
    name        : label;
    description : OPTIONAL text;
    kind        : document_type;
    INVERSE
        representation_types : SET [0:?] OF document_representation_type FOR
                                represented_document;
END_ENTITY; -- 10303-41: document_schema

ENTITY document_file
    SUBTYPE OF (characterized_object, document);
    WHERE
        WR1: (SIZEOF(QUERY (adr <* QUERY (dr <* USEDIN(SELF,
            'INTEGRATED_CNC_SCHEMA.DOCUMENT_REFERENCE.ASSIGNED_DOCUMENT')
            | ('INTEGRATED_CNC_SCHEMA.APPLIED_DOCUMENT_REFERENCE' IN
            TYPEOF(dr))) | (
            'INTEGRATED_CNC_SCHEMA.EXTERNALLY_DEFINED_FEATURE_DEFINITION'
            IN TYPEOF(adr.items)))) = 1) OR (SIZEOF(QUERY (duc <* USEDIN
            (SELF,
            'INTEGRATED_CNC_SCHEMA.DOCUMENT_USAGE_CONSTRAINT.SOURCE') |
            NOT (SIZEOF(QUERY (aduc <* QUERY (duca <* USEDIN(duc,
            'INTEGRATED_CNC_SCHEMA.DOCUMENT_USAGE_CONSTRAINT_ASSIGNMENT.'
            + 'ASSIGNED_DOCUMENT_USAGE') | ('INTEGRATED_CNC_SCHEMA.' +
            'APPLIED_DOCUMENT_USAGE_CONSTRAINT_ASSIGNMENT' IN TYPEOF(duca
            )) | (
            'INTEGRATED_CNC_SCHEMA.EXTERNALLY_DEFINED_FEATURE_DEFINITION'
            IN TYPEOF(aduc.items)))) = 1))) = 0);
        WR2: SIZEOF(QUERY (drt <* USEDIN(SELF, 'INTEGRATED_CNC_SCHEMA.' +
            'DOCUMENT_REPRESENTATION_TYPE.REPRESENTED_DOCUMENT') | (drt.
            name = 'physical')) = 1;
END_ENTITY; -- 10303-238: integrated_cnc_schema

ENTITY document_reference
    ABSTRACT SUPERTYPE;
    assigned_document : document;
    source            : label;
    DERIVE
        role : object_role := get_role(SELF);
    WHERE
        WR1: SIZEOF(USEDIN(SELF, 'INTEGRATED_CNC_SCHEMA.' +
            'ROLE_ASSOCIATION.ITEM_WITH_ROLE')) <= 1;
END_ENTITY; -- 10303-41: management_resources_schema

ENTITY document_representation_type;
    name          : label;
    represented_document : document;
END_ENTITY; -- 10303-41: document_schema

ENTITY document_type;
    product_data_type : label;
END_ENTITY; -- 10303-41: document_schema

ENTITY document_usage_constraint;

```

ISO 10303-238:2007(E)

```

        source                : document;
        subject_element       : label;
        subject_element_value : text;
END_ENTITY; -- 10303-41: document_schema

ENTITY document_usage_constraint_assignment
  ABSTRACT SUPERTYPE;
  assigned_document_usage : document_usage_constraint;
  role                    : document_usage_role;
END_ENTITY; -- 10303-41: management_resources_schema

ENTITY document_usage_role;
  name          : label;
  description   : OPTIONAL text;
END_ENTITY; -- 10303-41: management_resources_schema

ENTITY document_with_class
  SUBTYPE OF (document);
  class : identifier;
END_ENTITY; -- 10303-41: document_schema

ENTITY drilling_operation
  SUBTYPE OF (drilling_type_operation);
  WHERE
  WR1: (SELF.description IN ['drilling','counter sinking',
    'center drilling', 'multistep drilling']);

  WR2: NOT (SELF.description = 'multistep drilling') OR
    ((verify_required_action_property (SELF, 'retract distance')) AND
    (verify_length_measure_action_property (SELF, 'retract distance')) AND

    (verify_required_action_property (SELF, 'first depth')) AND
    (verify_length_measure_action_property (SELF, 'first depth')) AND

    (verify_required_action_property (SELF, 'depth of step')) AND
    (verify_length_measure_action_property (SELF, 'depth of step')) AND

    (verify_optional_action_property (SELF, 'dwell time step')) AND
    (verify_rep_type_for_action_property (SELF, 'dwell time step',
    ['INTEGRATED_CNC_SCHEMA.MACHINING_DWELL_TIME_REPRESENTATION'])) AND
    (verify_rep_name_for_action_property (SELF, 'dwell time step',
    ['dwell time']))
  );
END_ENTITY; -- 10303-238: integrated_cnc_schema

ENTITY drilling_type_operation
  SUBTYPE OF (machining_operation);
  WHERE
  WR1: (verify_optional_action_property (SELF, 'overcut length')) AND
    (verify_length_measure_action_property (SELF, 'overcut length'));

  WR2: (verify_optional_action_property (SELF, 'cutting depth')) AND
    (verify_length_measure_action_property (SELF, 'cutting depth'));

```

```

WR3: (verify_optional_action_property      (SELF, 'previous diameter')) AND
      (verify_length_measure_action_property (SELF, 'previous diameter'));

WR4: (verify_optional_action_property      (SELF, 'dwell time bottom')) AND
      (verify_rep_type_for_action_property (SELF, 'dwell time bottom',
      ['INTEGRATED_CNC_SCHEMA.MACHINING_DWELL_TIME_REPRESENTATION'])) AND
      (verify_rep_name_for_action_property (SELF, 'dwell time bottom',
      ['dwell time']));

WR5: (verify_optional_action_property      (SELF, 'feedrate on retract'))
AND
      (verify_rep_type_for_action_property (SELF, 'feedrate on retract',
      ['INTEGRATED_CNC_SCHEMA.MACHINING_FEED_SPEED_REPRESENTATION'])) AND
      (verify_rep_name_for_action_property (SELF, 'feedrate on retract',
      ['relative speed']));

WR6: ((verify_optional_relating_amr_with_name (SELF, 'machining',
      ['INTEGRATED_CNC_SCHEMA.MACHINING_STRATEGY_RELATIONSHIP'])) AND
      (verify_related_type_for_amr_with_name (SELF, 'machining',
      ['INTEGRATED_CNC_SCHEMA.MACHINING_STRATEGY_RELATIONSHIP'],
      ['INTEGRATED_CNC_SCHEMA.DRILLING_TYPE_STRATEGY']))
      );
END_ENTITY; -- 10303-238: integrated_cnc_schema

ENTITY drilling_type_strategy
  SUBTYPE OF (machining_strategy);
  WHERE
WR1: (verify_optional_action_property      (SELF, 'reduced cut at start')) AND
      (verify_rep_type_for_action_property (SELF, 'reduced cut at start',
      ['INTEGRATED_CNC_SCHEMA.MACHINING_SPINDLE_SPEED_REPRESENTATION'])) AND
      (verify_rep_name_for_action_property (SELF, 'reduced cut at start',
      ['relative speed']));

WR2: (verify_optional_action_property      (SELF, 'reduced feedrate at start')) AND
      (verify_rep_type_for_action_property (SELF, 'reduced feedrate at start',
      ['INTEGRATED_CNC_SCHEMA.MACHINING_FEED_SPEED_REPRESENTATION'])) AND
      (verify_rep_name_for_action_property (SELF, 'reduced feedrate at start',
      ['relative speed']));

WR3: (verify_optional_action_property      (SELF, 'depth of start')) AND
      (verify_length_measure_action_property (SELF, 'depth of start'));

WR4: (verify_optional_action_property      (SELF, 'reduced cut at end')) AND
      (verify_rep_type_for_action_property (SELF, 'reduced cut at end',
      ['INTEGRATED_CNC_SCHEMA.MACHINING_SPINDLE_SPEED_REPRESENTATION'])) AND
      (verify_rep_name_for_action_property (SELF, 'reduced cut at end',
      ['relative speed']));

WR5: (verify_optional_action_property

```

```

        (SELF, 'reduced feedrate at end')) AND
    (verify_rep_type_for_action_property
      (SELF, 'reduced feedrate at end',
        ['INTEGRATED_CNC_SCHEMA.MACHINING_FEED_SPEED_REPRESENTATION'])) AND
    (verify_rep_name_for_action_property
      (SELF, 'reduced feedrate at end',
        ['relative speed']));

WR6: (verify_optional_action_property      (SELF, 'depth of end')) AND
     (verify_length_measure_action_property (SELF, 'depth of end'));

WR7: (verify_required_action_property (SELF, 'depth of start')) OR
     ((0 = SIZEOF (get_action_property (SELF, 'reduced cut at start')) AND
      (0 = SIZEOF (get_action_property (SELF, 'reduced feedrate at
start'))));

WR8: (verify_required_action_property (SELF, 'depth of end')) OR
     ((0 = SIZEOF (get_action_property (SELF, 'reduced cut at end')) AND
      (0 = SIZEOF (get_action_property (SELF, 'reduced feedrate at end'))));
END_ENTITY; -- 10303-238: integrated_cnc_schema

ENTITY edge
  SUPERTYPE OF (ONEOF(edge_curve, oriented_edge))
  SUBTYPE OF (topological_representation_item);
  edge_start : vertex;
  edge_end   : vertex;
END_ENTITY; -- 10303-42: topology_schema

ENTITY edge_based_wireframe_model
  SUBTYPE OF (geometric_representation_item);
  ebwm_boundary : SET [1:?] OF connected_edge_set;
END_ENTITY; -- 10303-42: geometric_model_schema

ENTITY edge_based_wireframe_shape_representation
  SUBTYPE OF (shape_representation);
  WHERE
    WR1: SIZEOF(QUERY (it <* SELF.items| NOT (SIZEOF([
      'INTEGRATED_CNC_SCHEMA.EDGE_BASED_WIREFRAME_MODEL',
      'INTEGRATED_CNC_SCHEMA.MAPPED_ITEM',
      'INTEGRATED_CNC_SCHEMA.AXIS2_PLACEMENT_3D' ] * TYPEOF(it)) =
      1))) = 0;
    WR2: SIZEOF(QUERY (it <* SELF.items| (SIZEOF([
      'INTEGRATED_CNC_SCHEMA.EDGE_BASED_WIREFRAME_MODEL',
      'INTEGRATED_CNC_SCHEMA.MAPPED_ITEM' ] * TYPEOF(it)) = 1))) >=
      1;
    WR3: SIZEOF(QUERY (ebwm <* QUERY (it <* SELF.items| (
      'INTEGRATED_CNC_SCHEMA.EDGE_BASED_WIREFRAME_MODEL' IN TYPEOF(
      it)))| NOT (SIZEOF(QUERY (eb <* ebwm\
      edge_based_wireframe_model.ebwm_boundary| NOT (SIZEOF(QUERY (
      edges <* eb.ces_edges| NOT (
      'INTEGRATED_CNC_SCHEMA.EDGE_CURVE' IN TYPEOF(edges)))) = 0)))
      = 0))) = 0;
    WR4: SIZEOF(QUERY (ebwm <* QUERY (it <* SELF.items| (
      'INTEGRATED_CNC_SCHEMA.EDGE_BASED_WIREFRAME_MODEL' IN TYPEOF(

```

```

it)))| NOT (SIZEOF(QUERY (eb <* ebwm\
edge_based_wireframe_model.ebwm_boundary| NOT (SIZEOF(QUERY (
pline_edges <* QUERY (edges <* eb.ces_edges| (
'INTEGRATED_CNC_SCHEMA.POLYLINE' IN TYPEOF(edges\edge_curve.
edge_geometry)))| NOT (SIZEOF(pline_edges\edge_curve.
edge_geometry\polyline.points) > 2))) = 0))) = 0));
WR5: SIZEOF(QUERY (ebwm <* QUERY (it <* SELF.items| (
'INTEGRATED_CNC_SCHEMA.EDGE_BASED_WIREFRAME_MODEL' IN TYPEOF(
it)))| NOT (SIZEOF(QUERY (eb <* ebwm\
edge_based_wireframe_model.ebwm_boundary| NOT (SIZEOF(QUERY (
edges <* eb.ces_edges| NOT ((
'INTEGRATED_CNC_SCHEMA.VERTEX_POINT' IN TYPEOF(edges.
edge_start)) AND ('INTEGRATED_CNC_SCHEMA.VERTEX_POINT' IN
TYPEOF(edges.edge_end)))))) = 0))) = 0))) = 0;
WR6: SIZEOF(QUERY (ebwm <* QUERY (it <* SELF.items| (
'INTEGRATED_CNC_SCHEMA.EDGE_BASED_WIREFRAME_MODEL' IN TYPEOF(
it)))| NOT (SIZEOF(QUERY (eb <* ebwm\
edge_based_wireframe_model.ebwm_boundary| NOT (SIZEOF(QUERY (
edges <* eb.ces_edges| NOT valid_wireframe_edge_curve(edges\
edge_curve.edge_geometry))) = 0))) = 0))) = 0;
WR7: SIZEOF(QUERY (ebwm <* QUERY (it <* SELF.items| (
'INTEGRATED_CNC_SCHEMA.EDGE_BASED_WIREFRAME_MODEL' IN TYPEOF(
it)))| NOT (SIZEOF(QUERY (eb <* ebwm\
edge_based_wireframe_model.ebwm_boundary| NOT (SIZEOF(QUERY (
edges <* eb.ces_edges| NOT (valid_wireframe_vertex_point(
edges.edge_start\vertex_point.vertex_geometry) AND
valid_wireframe_vertex_point(edges.edge_end\vertex_point.
vertex_geometry)))))) = 0))) = 0))) = 0;
WR8: SIZEOF(QUERY (mi <* QUERY (it <* SELF.items| (
'INTEGRATED_CNC_SCHEMA.MAPPED_ITEM' IN TYPEOF(it)))| NOT (
'INTEGRATED_CNC_SCHEMA.' +
'EDGE_BASED_WIREFRAME_SHAPE_REPRESENTATION' IN TYPEOF(mi\
mapped_item.mapping_source.mapped_representation)))) = 0;
WR9: SELF.context_of_items\geometric_representation_context.
coordinate_space_dimension = 3;
END_ENTITY; -- 10303-501: aic_edge_based_wireframe

ENTITY edge_curve
  SUBTYPE OF (edge, geometric_representation_item);
  edge_geometry : curve;
  same_sense : BOOLEAN;
END_ENTITY; -- 10303-42: topology_schema

ENTITY edge_loop
  SUBTYPE OF (loop, path);
  DERIVE
    ne : INTEGER := SIZEOF(SELF\path.edge_list);
  WHERE
    WR1: SELF\path.edge_list[1].edge_start := SELF\path.edge_list[ne].
        edge_end;
END_ENTITY; -- 10303-42: topology_schema

ENTITY edge_round
  SUBTYPE OF (transition_feature);

```

WHERE

```

WR1: NOT (SELF\shape_aspect.description = 'constant radius') OR (SIZEOF
  (QUERY (pd <* USEDIN(SELF,
    'INTEGRATED_CNC_SCHEMA.PROPERTY_DEFINITION.DEFINITION')| NOT
    (SIZEOF(QUERY (pdr <* USEDIN(pd, 'INTEGRATED_CNC_SCHEMA.' +
    'PROPERTY_DEFINITION_REPRESENTATION.DEFINITION')| (
    'INTEGRATED_CNC_SCHEMA.SHAPE_REPRESENTATION_WITH_PARAMETERS'
    IN TYPEOF(pdr.used_representation)))) = 1))) = 0);
WR2: NOT (SELF\shape_aspect.description = 'constant radius') OR (SIZEOF
  (QUERY (pd <* USEDIN(SELF,
    'INTEGRATED_CNC_SCHEMA.PROPERTY_DEFINITION.DEFINITION')| NOT
    (SIZEOF(QUERY (impl_rep <* QUERY (pdr <* USEDIN(pd,
    'INTEGRATED_CNC_SCHEMA.' +
    'PROPERTY_DEFINITION_REPRESENTATION.DEFINITION')| (
    'INTEGRATED_CNC_SCHEMA.SHAPE_REPRESENTATION_WITH_PARAMETERS'
    IN TYPEOF(pdr.used_representation)))| NOT (SIZEOF(impl_rep.
    used_representation.items) >= 1) AND (SIZEOF(impl_rep.
    used_representation.items) <= 3))) = 0))) = 0);
WR3: NOT (SELF.description = 'constant radius') OR (SIZEOF(QUERY (pd <*
  USEDIN(SELF,
    'INTEGRATED_CNC_SCHEMA.PROPERTY_DEFINITION.DEFINITION')| NOT
    (SIZEOF(QUERY (impl_rep <* QUERY (pdr <* USEDIN(pd,
    'INTEGRATED_CNC_SCHEMA.' +
    'PROPERTY_DEFINITION_REPRESENTATION.DEFINITION')| (
    'INTEGRATED_CNC_SCHEMA.SHAPE_REPRESENTATION_WITH_PARAMETERS'
    IN TYPEOF(pdr.used_representation)))| NOT (SIZEOF(QUERY (it
    <* impl_rep.used_representation.items| (SIZEOF([
    'INTEGRATED_CNC_SCHEMA.MEASURE_REPRESENTATION_ITEM',
    'INTEGRATED_CNC_SCHEMA.LENGTH_MEASURE_WITH_UNIT' ] * TYPEOF(
    it)) = 2) AND (it.name = 'radius')))) = 1))) = 0))) = 0);
WR4: NOT (SELF.description = 'constant radius') OR (SIZEOF(QUERY (pd <*
  USEDIN(SELF,
    'INTEGRATED_CNC_SCHEMA.PROPERTY_DEFINITION.DEFINITION')| NOT
    (SIZEOF(QUERY (impl_rep <* QUERY (pdr <* USEDIN(pd,
    'INTEGRATED_CNC_SCHEMA.' +
    'PROPERTY_DEFINITION_REPRESENTATION.DEFINITION')| (
    'INTEGRATED_CNC_SCHEMA.SHAPE_REPRESENTATION_WITH_PARAMETERS'
    IN TYPEOF(pdr.used_representation)))| NOT (SIZEOF(QUERY (it
    <* impl_rep.used_representation.items| (SIZEOF([
    'INTEGRATED_CNC_SCHEMA.MEASURE_REPRESENTATION_ITEM',
    'INTEGRATED_CNC_SCHEMA.LENGTH_MEASURE_WITH_UNIT' ] * TYPEOF(
    it)) = 2) AND (it.name = 'first offset')))) <= 1))) = 0))) = 0
  );
WR5: NOT (SELF.description = 'constant radius') OR (SIZEOF(QUERY (pd <*
  USEDIN(SELF,
    'INTEGRATED_CNC_SCHEMA.PROPERTY_DEFINITION.DEFINITION')| NOT
    (SIZEOF(QUERY (impl_rep <* QUERY (pdr <* USEDIN(pd,
    'INTEGRATED_CNC_SCHEMA.' +
    'PROPERTY_DEFINITION_REPRESENTATION.DEFINITION')| (
    'INTEGRATED_CNC_SCHEMA.SHAPE_REPRESENTATION_WITH_PARAMETERS'
    IN TYPEOF(pdr.used_representation)))| NOT (SIZEOF(QUERY (it
    <* impl_rep.used_representation.items| (SIZEOF([
    'INTEGRATED_CNC_SCHEMA.MEASURE_REPRESENTATION_ITEM',
    'INTEGRATED_CNC_SCHEMA.LENGTH_MEASURE_WITH_UNIT' ] * TYPEOF(

```

```

it)) = 2) AND (it.name = 'second offset')) <= 1))) = 0))) =
0);
WR6: SIZEOF(QUERY (pd <* USEDIN(SELF,
  'INTEGRATED_CNC_SCHEMA.PROPERTY_DEFINITION.DEFINITION')| NOT
(SIZEOF(QUERY (pdr <* USEDIN(pd, 'INTEGRATED_CNC_SCHEMA.' +
  'PROPERTY_DEFINITION_REPRESENTATION.DEFINITION')| (
  'INTEGRATED_CNC_SCHEMA.FACE_SHAPE_REPRESENTATION' IN TYPEOF(
  pdr.used_representation)) AND (pdr.used_representation.name =
  'edge round face')) <= 1))) = 0;
WR7: SIZEOF(QUERY (pd <* USEDIN(SELF,
  'INTEGRATED_CNC_SCHEMA.PROPERTY_DEFINITION.DEFINITION')| NOT
(SIZEOF(QUERY (pdr <* USEDIN(pd, 'INTEGRATED_CNC_SCHEMA.' +
  'PROPERTY_DEFINITION_REPRESENTATION.DEFINITION')| (
  'INTEGRATED_CNC_SCHEMA.FACE_SHAPE_REPRESENTATION' IN TYPEOF(
  pdr.used_representation)) AND (pdr.used_representation.name =
  'first face shape')) <= 1))) = 0;
WR8: SIZEOF(QUERY (pd <* USEDIN(SELF,
  'INTEGRATED_CNC_SCHEMA.PROPERTY_DEFINITION.DEFINITION')| NOT
(SIZEOF(QUERY (pdr <* USEDIN(pd, 'INTEGRATED_CNC_SCHEMA.' +
  'PROPERTY_DEFINITION_REPRESENTATION.DEFINITION')| (
  'INTEGRATED_CNC_SCHEMA.FACE_SHAPE_REPRESENTATION' IN TYPEOF(
  pdr.used_representation)) AND (pdr.used_representation.name =
  'second face shape')) <= 1))) = 0;
END_ENTITY; -- 10303-522: aic_machining_feature

ENTITY elementary_surface
  SUPERTYPE OF (ONEOF(plane, cylindrical_surface, conical_surface,
    spherical_surface, toroidal_surface))
  SUBTYPE OF (surface);
  position : axis2_placement_3d;
END_ENTITY; -- 10303-42: geometry_schema

ENTITY ellipse
  SUBTYPE OF (conic);
  semi_axis_1 : positive_length_measure;
  semi_axis_2 : positive_length_measure;
END_ENTITY; -- 10303-42: geometry_schema

ENTITY environment;
  syntactic_representation : generic_variable;
  semantics : variable_semantics;
END_ENTITY; -- 13584-20: iso13584_generic_expressions_schema

ENTITY evaluated_degenerate_pcurve
  SUBTYPE OF (degenerate_pcurve);
  equivalent_point : cartesian_point;
END_ENTITY; -- 10303-42: geometry_schema

ENTITY expanded_uncertainty
  SUBTYPE OF (standard_uncertainty);
  coverage_factor : REAL;
END_ENTITY; -- 10303-45: qualified_measure_schema

ENTITY expression

```

## ISO 10303-238:2007(E)

```
ABSTRACT SUPERTYPE OF (ONEOF(numeric_expression, boolean_expression))
SUBTYPE OF (generic_expression);
END_ENTITY; -- 13584-20: iso13584_expressions_schema

ENTITY expression_representation_item
  SUBTYPE OF (representation_item, generic_expression);
END_ENTITY; -- 10303-238: integrated_cnc_schema

ENTITY extension
  SUBTYPE OF (derived_shape_aspect);
  WHERE
    WR1: SIZEOF(SELF\derived_shape_aspect.deriving_relationships) = 1;
END_ENTITY; -- 10303-47: shape_aspect_definition_schema

ENTITY external_identification_assignment
  ABSTRACT SUPERTYPE
  SUBTYPE OF (identification_assignment);
  source : external_source;
END_ENTITY; -- 10303-41: management_resources_schema

ENTITY external_source;
  source_id : source_item;
  DERIVE
    description : text := get_description_value(SELF);
  WHERE
    WR1: SIZEOF(USEDIN(SELF, 'INTEGRATED_CNC_SCHEMA.' +
      'DESCRIPTION_ATTRIBUTE.DESCRIBED_ITEM')) <= 1;
END_ENTITY; -- 10303-41: external_reference_schema

ENTITY externally_defined_class
  SUBTYPE OF (externally_defined_item, class);
  WHERE
    WR1: 'INTEGRATED_CNC_SCHEMA.KNOWN_SOURCE' IN TYPEOF(SELF.source);
    WR2: SELF.source.name = 'ISO 13584 library';
    WR3: SIZEOF(QUERY (aoa <* USEDIN(SELF.source,
      'INTEGRATED_CNC_SCHEMA.APPLIED_ORGANIZATION_ASSIGNMENT.ITEMS'
    )| (aoa.role.name = 'library supplier')) = 1;
    WR4: SIZEOF(QUERY (aoa <* USEDIN(SELF, 'INTEGRATED_CNC_SCHEMA.' +
      'APPLIED_EXTERNAL_IDENTIFICATION_ASSIGNMENT.ITEMS')| (aoa.
      role.name = 'class version')) = 1;
END_ENTITY; -- 10303-238: integrated_cnc_schema

ENTITY externally_defined_dimension_definition
  SUBTYPE OF (externally_defined_item, dimensional_size);
  WHERE
    WR1: (SELF\externally_defined_item.item_id = 'external size dimension')
      AND (SELF\externally_defined_item.source.source_id =
      'external size dimension specification');
    WR2: 1 >= SIZEOF(QUERY (adr <* USEDIN(SELF,
      'INTEGRATED_CNC_SCHEMA.APPLIED_DOCUMENT_REFERENCE.ITEMS')| (
      adr.assigned_document.description =
      'external size dimension specification')));
END_ENTITY; -- 10303-238: integrated_cnc_schema
```



```

ENTITY externally_defined_feature_definition
  SUBTYPE OF (feature_definition, externally_defined_item);
WHERE
  WR1: (((SELF\characterized_object.description = 'thread') AND (SELF\
    externally_defined_item.item_id = 'external thread')) AND (
    SELF\externally_defined_item.source.source_id =
    'external feature specification') OR ((SELF\
    characterized_object.description = 'gear') AND (SELF\
    externally_defined_item.item_id = 'external gear')) AND (SELF\
    \externally_defined_item.source.source_id =
    'external feature specification')) OR ((SELF\
    characterized_object.description = 'marking') AND (SELF\
    externally_defined_item.item_id = 'external marking')) AND (
    SELF\externally_defined_item.source.source_id =
    'external feature specification')) OR ((SELF\
    characterized_object.description = 'knurl') AND (SELF\
    externally_defined_item.item_id = 'external knurl')) AND (
    SELF\externally_defined_item.source.source_id =
    'external feature specification');
  WR2: NOT (SELF\characterized_object.description = 'thread') OR (SIZEOF(
    QUERY (pd <* USEDIN(SELF,
    'INTEGRATED_CNC_SCHEMA.PROPERTY_DEFINITION.DEFINITION') | (
    SIZEOF(QUERY (pdr <* USEDIN(pd, 'INTEGRATED_CNC_SCHEMA.' +
    'PROPERTY_DEFINITION_REPRESENTATION.DEFINITION') | (
    'INTEGRATED_CNC_SCHEMA.' +
    'SHAPE_REPRESENTATION_WITH_PARAMETERS' IN TYPEOF(pdr.
    used_representation)) AND ((5 <= SIZEOF(pdr.
    used_representation.items)) AND (SIZEOF(pdr.
    used_representation.items) <= 10)))) = 1))) = 1);
  WR3: NOT (SELF\characterized_object.description = 'marking') OR (SIZEOF(
    QUERY (pd <* USEDIN(SELF,
    'INTEGRATED_CNC_SCHEMA.PROPERTY_DEFINITION.DEFINITION') | (
    SIZEOF(QUERY (pdr <* USEDIN(pd, 'INTEGRATED_CNC_SCHEMA.' +
    'PROPERTY_DEFINITION_REPRESENTATION.DEFINITION') | (
    'INTEGRATED_CNC_SCHEMA.' +
    'SHAPE_REPRESENTATION_WITH_PARAMETERS' IN TYPEOF(pdr.
    used_representation)) AND (SIZEOF(pdr.used_representation.
    items) = 2))) = 1))) = 1);
  WR4: NOT (SELF\characterized_object.description = 'knurl') OR (SIZEOF(
    QUERY (pd <* USEDIN(SELF,
    'INTEGRATED_CNC_SCHEMA.PROPERTY_DEFINITION.DEFINITION') | (
    SIZEOF(QUERY (pdr <* USEDIN(pd, 'INTEGRATED_CNC_SCHEMA.' +
    'PROPERTY_DEFINITION_REPRESENTATION.DEFINITION') | (
    'INTEGRATED_CNC_SCHEMA.' +
    'SHAPE_REPRESENTATION_WITH_PARAMETERS' IN TYPEOF(pdr.
    used_representation)) AND (SIZEOF(pdr.used_representation.
    items) = 1))) = 1))) = 1);
  WR5: NOT (SELF\characterized_object.description IN [ 'knurl', 'thread'
  ]) OR (SIZEOF(QUERY (pds <* QUERY (pd <* USEDIN(SELF,
    'INTEGRATED_CNC_SCHEMA.PROPERTY_DEFINITION.DEFINITION') | (
    'INTEGRATED_CNC_SCHEMA.PRODUCT_DEFINITION_SHAPE' IN TYPEOF(pd
    ))) | NOT (SIZEOF(QUERY (sa_occ <* USEDIN(pds,
    'INTEGRATED_CNC_SCHEMA.SHAPE_ASPECT.OF_SHAPE') | (sa_occ.
    description = 'partial area occurrence') AND (SIZEOF(QUERY (

```

```

sdr <* QUERY (sar <* USEDIN(sa_occ,
'INTEGRATED_CNC_SCHEMA.SHAPE_ASPECT_RELATIONSHIP.' +
'RELATED_SHAPE_ASPECT')| (sar.description =
'applied area usage') AND (
'INTEGRATED_CNC_SCHEMA.SHAPE_DEFINING_RELATIONSHIP' IN TYPEOF
(sar)))| ('INTEGRATED_CNC_SCHEMA.APPLIED_AREA' IN TYPEOF(sdr.
relating_shape_aspect)))) = 1))) <= 1))) = 0);
WR6: NOT (SELF\characterized_object.description = 'marking') OR (SIZEOF
(QUERY (pd <* USEDIN(SELF,
'INTEGRATED_CNC_SCHEMA.PROPERTY_DEFINITION.DEFINITION')| NOT
(SIZEOF(QUERY (impl_rep <* QUERY (pdr <* USEDIN(pd,
'INTEGRATED_CNC_SCHEMA.' +
'PROPERTY_DEFINITION_REPRESENTATION.DEFINITION')| (
'INTEGRATED_CNC_SCHEMA.' +
'SHAPE_REPRESENTATION_WITH_PARAMETERS' IN TYPEOF(pdr.
used_representation))))| NOT (SIZEOF(QUERY (it <* impl_rep.
used_representation.items| (
'INTEGRATED_CNC_SCHEMA.DESRIPTIVE_REPRESENTATION_ITEM' IN
TYPEOF(it)) AND (it.name = 'marking text')) = 1))) = 0))) =
0);
WR7: NOT (SELF\characterized_object.description = 'thread') OR (SIZEOF(
QUERY (pd <* USEDIN(SELF,
'INTEGRATED_CNC_SCHEMA.PROPERTY_DEFINITION.DEFINITION')| NOT
(SIZEOF(QUERY (impl_rep <* QUERY (pdr <* USEDIN(pd,
'INTEGRATED_CNC_SCHEMA.' +
'PROPERTY_DEFINITION_REPRESENTATION.DEFINITION')| (
'INTEGRATED_CNC_SCHEMA.' +
'SHAPE_REPRESENTATION_WITH_PARAMETERS' IN TYPEOF(pdr.
used_representation))))| NOT (SIZEOF(QUERY (it <* impl_rep.
used_representation.items| ((
'INTEGRATED_CNC_SCHEMA.DESRIPTIVE_REPRESENTATION_ITEM' IN
TYPEOF(it)) AND (it.name = 'removal direction')) AND ((it.
description = 'internal') OR (it.description = 'external'))))
= 1))) = 0))) = 0);
WR8: NOT (SELF\characterized_object.description = 'thread') OR (SIZEOF(
QUERY (pd <* USEDIN(SELF,
'INTEGRATED_CNC_SCHEMA.PROPERTY_DEFINITION.DEFINITION')| NOT
(SIZEOF(QUERY (impl_rep <* QUERY (pdr <* USEDIN(pd,
'INTEGRATED_CNC_SCHEMA.' +
'PROPERTY_DEFINITION_REPRESENTATION.DEFINITION')| (
'INTEGRATED_CNC_SCHEMA.' +
'SHAPE_REPRESENTATION_WITH_PARAMETERS' IN TYPEOF(pdr.
used_representation))))| NOT (SIZEOF(QUERY (it <* impl_rep.
used_representation.items| (
'INTEGRATED_CNC_SCHEMA.DESRIPTIVE_REPRESENTATION_ITEM' IN
TYPEOF(it)) AND (it.name = 'qualifier')) <= 1))) = 0))) = 0)
;
WR9: NOT (SELF\characterized_object.description = 'thread') OR (SIZEOF(
QUERY (pd <* USEDIN(SELF,
'INTEGRATED_CNC_SCHEMA.PROPERTY_DEFINITION.DEFINITION')| NOT
(SIZEOF(QUERY (impl_rep <* QUERY (pdr <* USEDIN(pd,
'INTEGRATED_CNC_SCHEMA.' +
'PROPERTY_DEFINITION_REPRESENTATION.DEFINITION')| (
'INTEGRATED_CNC_SCHEMA.' +

```

```

'SHAPE_REPRESENTATION_WITH_PARAMETERS' IN TYPEOF(pdr.
used_representation)))| NOT (SIZEOF(QUERY (it <* impl_rep.
used_representation.items| (
'INTEGRATED_CNC_SCHEMA.DESRIPTIVE_REPRESENTATION_ITEM' IN
TYPEOF(it)) AND (it.name = 'hand')))) = 1))) = 0))) = 0);
WR10: NOT (SELF\characterized_object.description = 'thread') OR (SIZEOF
(QUERY (pd <* USEDIN(SELF,
'INTEGRATED_CNC_SCHEMA.PROPERTY_DEFINITION.DEFINITION')| NOT
(SIZEOF(QUERY (impl_rep <* QUERY (pdr <* USEDIN(pd,
'INTEGRATED_CNC_SCHEMA.' +
'PROPERTY_DEFINITION_REPRESENTATION.DEFINITION')| (
'INTEGRATED_CNC_SCHEMA.' +
'SHAPE_REPRESENTATION_WITH_PARAMETERS' IN TYPEOF(pdr.
used_representation)))| NOT (SIZEOF(QUERY (it <* impl_rep.
used_representation.items| (
'INTEGRATED_CNC_SCHEMA.DESRIPTIVE_REPRESENTATION_ITEM' IN
TYPEOF(it)) AND (it.name = 'fit class')))) = 1))) = 0))) = 0);
WR11: NOT (SELF\characterized_object.description = 'thread') OR (SIZEOF
(QUERY (pd <* USEDIN(SELF,
'INTEGRATED_CNC_SCHEMA.PROPERTY_DEFINITION.DEFINITION')| NOT
(SIZEOF(QUERY (impl_rep <* QUERY (pdr <* USEDIN(pd,
'INTEGRATED_CNC_SCHEMA.' +
'PROPERTY_DEFINITION_REPRESENTATION.DEFINITION')| (
'INTEGRATED_CNC_SCHEMA.' +
'SHAPE_REPRESENTATION_WITH_PARAMETERS' IN TYPEOF(pdr.
used_representation)))| NOT (SIZEOF(QUERY (it <* impl_rep.
used_representation.items| (
'INTEGRATED_CNC_SCHEMA.DESRIPTIVE_REPRESENTATION_ITEM' IN
TYPEOF(it)) AND (it.name = 'form')))) = 1))) = 0))) = 0);
WR12: NOT (SELF\characterized_object.description = 'thread') OR (SIZEOF
(QUERY (pd <* USEDIN(SELF,
'INTEGRATED_CNC_SCHEMA.PROPERTY_DEFINITION.DEFINITION')| NOT
(SIZEOF(QUERY (impl_rep <* QUERY (pdr <* USEDIN(pd,
'INTEGRATED_CNC_SCHEMA.' +
'PROPERTY_DEFINITION_REPRESENTATION.DEFINITION')| (
'INTEGRATED_CNC_SCHEMA.' +
'SHAPE_REPRESENTATION_WITH_PARAMETERS' IN TYPEOF(pdr.
used_representation)))| NOT (SIZEOF(QUERY (it <* impl_rep.
used_representation.items| (SIZEOF([
'INTEGRATED_CNC_SCHEMA.MEASURE_REPRESENTATION_ITEM',
'INTEGRATED_CNC_SCHEMA.LENGTH_MEASURE_WITH_UNIT' ] * TYPEOF(
it)) = 2) AND (it.name = 'major diameter')))) <= 1))) = 0))) =
0);
WR13: NOT (SELF\characterized_object.description = 'thread') OR (SIZEOF
(QUERY (pd <* USEDIN(SELF,
'INTEGRATED_CNC_SCHEMA.PROPERTY_DEFINITION.DEFINITION')| NOT
(SIZEOF(QUERY (impl_rep <* QUERY (pdr <* USEDIN(pd,
'INTEGRATED_CNC_SCHEMA.' +
'PROPERTY_DEFINITION_REPRESENTATION.DEFINITION')| (
'INTEGRATED_CNC_SCHEMA.' +
'SHAPE_REPRESENTATION_WITH_PARAMETERS' IN TYPEOF(pdr.
used_representation)))| NOT (SIZEOF(QUERY (it <* impl_rep.
used_representation.items| (SIZEOF([
'INTEGRATED_CNC_SCHEMA.MEASURE_REPRESENTATION_ITEM',

```

```

        'INTEGRATED_CNC_SCHEMA.RATIO_MEASURE_WITH_UNIT' ] * TYPEOF(it
    )) = 2) AND (it.name = 'number of threads')) = 1))) = 0))) =
    0);
WR14: SIZEOF(QUERY (pd <* USEDIN(SELF,
    'INTEGRATED_CNC_SCHEMA.PROPERTY_DEFINITION.DEFINITION')| NOT
    (SIZEOF(QUERY (impl_rep <* QUERY (pdr <* USEDIN(pd,
    'INTEGRATED_CNC_SCHEMA.' +
    'PROPERTY_DEFINITION_REPRESENTATION.DEFINITION')| (
    'INTEGRATED_CNC_SCHEMA.' +
    'SHAPE_REPRESENTATION_WITH_PARAMETERS' IN TYPEOF(pdr.
    used_representation)))| NOT (SIZEOF(QUERY (it <* impl_rep.
    used_representation.items| (
    'INTEGRATED_CNC_SCHEMA.DESCRPTIVE_REPRESENTATION_ITEM' IN
    TYPEOF(it)) AND (it.name = 'fit class 2')) <= 1))) = 0))) =
    0;
WR15: SIZEOF(QUERY (pd <* USEDIN(SELF,
    'INTEGRATED_CNC_SCHEMA.PROPERTY_DEFINITION.DEFINITION')| NOT
    (SIZEOF(QUERY (impl_rep <* QUERY (pdr <* USEDIN(pd,
    'INTEGRATED_CNC_SCHEMA.' +
    'PROPERTY_DEFINITION_REPRESENTATION.DEFINITION')| (
    'INTEGRATED_CNC_SCHEMA.' +
    'SHAPE_REPRESENTATION_WITH_PARAMETERS' IN TYPEOF(pdr.
    used_representation)))| NOT (SIZEOF(QUERY (it <* impl_rep.
    used_representation.items| (SIZEOF([
    'INTEGRATED_CNC_SCHEMA.MEASURE_REPRESENTATION_ITEM',
    'INTEGRATED_CNC_SCHEMA.LENGTH_MEASURE_WITH_UNIT' ] * TYPEOF(
    it)) = 2) AND (it.name = 'nominal size')) <= 1))) = 0))) = 0
    ;
WR16: NOT (SELF\characterized_object.description IN [ 'knurl', 'gear',
    'thread' ]) OR (SIZEOF(QUERY (pds <* QUERY (pd <* USEDIN(SELF
    , 'INTEGRATED_CNC_SCHEMA.PROPERTY_DEFINITION.DEFINITION')| (
    'INTEGRATED_CNC_SCHEMA.PRODUCT_DEFINITION_SHAPE' IN TYPEOF(pd
    )))| NOT (SIZEOF(QUERY (sa_occ <* USEDIN(pds,
    'INTEGRATED_CNC_SCHEMA.SHAPE_ASPECT.OF_SHAPE')| (SIZEOF(QUERY
    (sdr <* QUERY (sar <* USEDIN(sa_occ,
    'INTEGRATED_CNC_SCHEMA.SHAPE_ASPECT_RELATIONSHIP.' +
    'RELATED_SHAPE_ASPECT')| (sar.description = 'applied shape')
    AND ('INTEGRATED_CNC_SCHEMA.SHAPE_DEFINING_RELATIONSHIP' IN
    TYPEOF(sar)))| ('INTEGRATED_CNC_SCHEMA.SHAPE_ASPECT' IN
    TYPEOF(sdr.relatng_shape_aspect)))) = 1))) <= 1))) = 0);
WR17: NOT (SELF\characterized_object.description IN [ 'gear' ]) OR (
    SIZEOF(QUERY (pd <* USEDIN(SELF,
    'INTEGRATED_CNC_SCHEMA.PROPERTY_DEFINITION.DEFINITION')| (
    SIZEOF(QUERY (pdr <* USEDIN(pd, 'INTEGRATED_CNC_SCHEMA.' +
    'PROPERTY_DEFINITION_REPRESENTATION.DEFINITION')| ((
    'INTEGRATED_CNC_SCHEMA.' +
    'SHAPE_REPRESENTATION_WITH_PARAMETERS' IN TYPEOF(pdr.
    used_representation)) AND (10 <= SIZEOF(pdr.
    used_representation.items))) AND (SIZEOF(pdr.
    used_representation.items) >= 11))) = 1))) = 1);
WR18: NOT (SELF\characterized_object.description IN [ 'gear' ]) OR (
    SIZEOF(QUERY (pd <* USEDIN(SELF,
    'INTEGRATED_CNC_SCHEMA.PROPERTY_DEFINITION.DEFINITION')| NOT
    (SIZEOF(QUERY (impl_rep <* QUERY (pdr <* USEDIN(pd,

```

```

'INTEGRATED_CNC_SCHEMA.' +
'PROPERTY_DEFINITION_REPRESENTATION.DEFINITION')| (
'INTEGRATED_CNC_SCHEMA.' +
'SHAPE_REPRESENTATION_WITH_PARAMETERS' IN TYPEOF(pdr.
used_representation)))| NOT (SIZEOF(QUERY (it <* impl_rep.
used_representation.items| (SIZEOF([
'INTEGRATED_CNC_SCHEMA.MEASURE_REPRESENTATION_ITEM',
'INTEGRATED_CNC_SCHEMA.RATIO_MEASURE_WITH_UNIT' ] * TYPEOF(it
)) = 2) AND (it.name = 'number of teeth'))) = 1))) = 0))
);
WR19: NOT (SELF\characterized_object.description IN [ 'gear' ]) OR (
SIZEOF(QUERY (pd <* USEDIN(SELF,
'INTEGRATED_CNC_SCHEMA.PROPERTY_DEFINITION.DEFINITION')| NOT
(SIZEOF(QUERY (impl_rep <* QUERY (pdr <* USEDIN(pd,
'INTEGRATED_CNC_SCHEMA.' +
'PROPERTY_DEFINITION_REPRESENTATION.DEFINITION')| (
'INTEGRATED_CNC_SCHEMA.' +
'SHAPE_REPRESENTATION_WITH_PARAMETERS' IN TYPEOF(pdr.
used_representation)))| NOT (SIZEOF(QUERY (it <* impl_rep.
used_representation.items| (SIZEOF([
'INTEGRATED_CNC_SCHEMA.MEASURE_REPRESENTATION_ITEM',
'INTEGRATED_CNC_SCHEMA.PLANE_ANGLE_MEASURE_WITH_UNIT' ] *
TYPEOF(it)) = 2) AND (it.name = 'reference pressure angle')))
= 1))) = 0))) = 0);
WR20: NOT (SELF\characterized_object.description IN [ 'gear' ]) OR (
SIZEOF(QUERY (pd <* USEDIN(SELF,
'INTEGRATED_CNC_SCHEMA.PROPERTY_DEFINITION.DEFINITION')| NOT
(SIZEOF(QUERY (impl_rep <* QUERY (pdr <* USEDIN(pd,
'INTEGRATED_CNC_SCHEMA.' +
'PROPERTY_DEFINITION_REPRESENTATION.DEFINITION')| (
'INTEGRATED_CNC_SCHEMA.' +
'SHAPE_REPRESENTATION_WITH_PARAMETERS' IN TYPEOF(pdr.
used_representation)))| NOT (SIZEOF(QUERY (it <* impl_rep.
used_representation.items| (SIZEOF([
'INTEGRATED_CNC_SCHEMA.MEASURE_REPRESENTATION_ITEM',
'INTEGRATED_CNC_SCHEMA.LENGTH_MEASURE_WITH_UNIT' ] * TYPEOF(
it)) = 2) AND (it.name = 'rake shift factor'))) = 1))) = 0)))
= 0);
WR21: NOT (SELF\characterized_object.description IN [ 'gear' ]) OR (
SIZEOF(QUERY (pd <* USEDIN(SELF,
'INTEGRATED_CNC_SCHEMA.PROPERTY_DEFINITION.DEFINITION')| NOT
(SIZEOF(QUERY (impl_rep <* QUERY (pdr <* USEDIN(pd,
'INTEGRATED_CNC_SCHEMA.' +
'PROPERTY_DEFINITION_REPRESENTATION.DEFINITION')| (
'INTEGRATED_CNC_SCHEMA.' +
'SHAPE_REPRESENTATION_WITH_PARAMETERS' IN TYPEOF(pdr.
used_representation)))| NOT (SIZEOF(QUERY (it <* impl_rep.
used_representation.items| (SIZEOF([
'INTEGRATED_CNC_SCHEMA.MEASURE_REPRESENTATION_ITEM',
'INTEGRATED_CNC_SCHEMA.LENGTH_MEASURE_WITH_UNIT' ] * TYPEOF(
it)) = 2) AND (it.name = 'nominal tooth depth'))) = 1))) = 0
)) = 0);
WR22: NOT (SELF\characterized_object.description IN [ 'gear' ]) OR (
SIZEOF(QUERY (pd <* USEDIN(SELF,

```

```

        'INTEGRATED_CNC_SCHEMA.PROPERTY_DEFINITION.DEFINITION')| NOT
        (SIZEOF(QUERY (impl_rep <* QUERY (pdr <* USEDIN(pd,
        'INTEGRATED_CNC_SCHEMA.' +
        'PROPERTY_DEFINITION_REPRESENTATION.DEFINITION')| (
        'INTEGRATED_CNC_SCHEMA.' +
        'SHAPE_REPRESENTATION_WITH_PARAMETERS' IN TYPEOF(pdr.
        used_representation)))| NOT (SIZEOF(QUERY (it <* impl_rep.
        used_representation.items| (SIZEOF([
        'INTEGRATED_CNC_SCHEMA.MEASURE_REPRESENTATION_ITEM',
        'INTEGRATED_CNC_SCHEMA.LENGTH_MEASURE_WITH_UNIT' ] * TYPEOF(
        it)) = 2) AND (it.name = 'face width')) = 1))) = 0))) = 0);
WR23: NOT (SELF\characterized_object.description IN [ 'gear' ]) OR (
        SIZEOF(QUERY (pd <* USEDIN(SELF,
        'INTEGRATED_CNC_SCHEMA.PROPERTY_DEFINITION.DEFINITION')| NOT
        (SIZEOF(QUERY (impl_rep <* QUERY (pdr <* USEDIN(pd,
        'INTEGRATED_CNC_SCHEMA.' +
        'PROPERTY_DEFINITION_REPRESENTATION.DEFINITION')| (
        'INTEGRATED_CNC_SCHEMA.' +
        'SHAPE_REPRESENTATION_WITH_PARAMETERS' IN TYPEOF(pdr.
        used_representation)))| NOT (SIZEOF(QUERY (it <* impl_rep.
        used_representation.items| (SIZEOF([
        'INTEGRATED_CNC_SCHEMA.MEASURE_REPRESENTATION_ITEM',
        'INTEGRATED_CNC_SCHEMA.LENGTH_MEASURE_WITH_UNIT' ] * TYPEOF(
        it)) = 2) AND (it.name = 'tip diameter')) = 1))) = 0))) = 0)
        ;
WR24: NOT (SELF\characterized_object.description IN [ 'gear' ]) OR (
        SIZEOF(QUERY (pd <* USEDIN(SELF,
        'INTEGRATED_CNC_SCHEMA.PROPERTY_DEFINITION.DEFINITION')| NOT
        (SIZEOF(QUERY (impl_rep <* QUERY (pdr <* USEDIN(pd,
        'INTEGRATED_CNC_SCHEMA.' +
        'PROPERTY_DEFINITION_REPRESENTATION.DEFINITION')| (
        'INTEGRATED_CNC_SCHEMA.' +
        'SHAPE_REPRESENTATION_WITH_PARAMETERS' IN TYPEOF(pdr.
        used_representation)))| NOT (SIZEOF(QUERY (it <* impl_rep.
        used_representation.items| ((
        'INTEGRATED_CNC_SCHEMA.DESRIPTIVE_REPRESENTATION_ITEM' IN
        TYPEOF(it)) AND (it.name = 'module or diametral pitch')) AND
        ((it.description = 'module') OR (it.description =
        'diametral pitch')))) = 1))) = 0))) = 0);
WR25: NOT (SELF\characterized_object.description IN [ 'gear' ]) OR (
        SIZEOF(QUERY (pd <* USEDIN(SELF,
        'INTEGRATED_CNC_SCHEMA.PROPERTY_DEFINITION.DEFINITION')| NOT
        (SIZEOF(QUERY (impl_rep <* QUERY (pdr <* USEDIN(pd,
        'INTEGRATED_CNC_SCHEMA.' +
        'PROPERTY_DEFINITION_REPRESENTATION.DEFINITION')| (
        'INTEGRATED_CNC_SCHEMA.' +
        'SHAPE_REPRESENTATION_WITH_PARAMETERS' IN TYPEOF(pdr.
        used_representation)))| NOT (SIZEOF(QUERY (it <* impl_rep.
        used_representation.items| (SIZEOF([
        'INTEGRATED_CNC_SCHEMA.MEASURE_REPRESENTATION_ITEM',
        'INTEGRATED_CNC_SCHEMA.LENGTH_MEASURE_WITH_UNIT' ] * TYPEOF(
        it)) = 2) AND (it.name = 'normal attribute')) = 1))) = 0)))
        = 0);
WR26: NOT (SELF\characterized_object.description IN [ 'gear' ]) OR (

```

```

        SIZEOF(QUERY (pd <* USEDIN(SELF,
        'INTEGRATED_CNC_SCHEMA.PROPERTY_DEFINITION.DEFINITION')| NOT
        (SIZEOF(QUERY (impl_rep <* QUERY (pdr <* USEDIN(pd,
        'INTEGRATED_CNC_SCHEMA.' +
        'PROPERTY_DEFINITION_REPRESENTATION.DEFINITION')| (
        'INTEGRATED_CNC_SCHEMA.' +
        'SHAPE_REPRESENTATION_WITH_PARAMETERS' IN TYPEOF(pdr.
        used_representation)))| NOT (SIZEOF(QUERY (it <* impl_rep.
        used_representation.items| ((
        'INTEGRATED_CNC_SCHEMA.DESCRPTIVE_REPRESENTATION_ITEM' IN
        TYPEOF(it)) AND (it.name = 'internal or external gear')) AND
        ((it.description = 'internal') OR (it.description =
        'external')))) = 1))) = 0))) = 0);
    WR27: NOT (SELF\characterized_object.description IN [ 'gear' ]) OR (
        SIZEOF(QUERY (pd <* USEDIN(SELF,
        'INTEGRATED_CNC_SCHEMA.PROPERTY_DEFINITION.DEFINITION')| NOT
        (SIZEOF(QUERY (impl_rep <* QUERY (pdr <* USEDIN(pd,
        'INTEGRATED_CNC_SCHEMA.' +
        'PROPERTY_DEFINITION_REPRESENTATION.DEFINITION')| (
        'INTEGRATED_CNC_SCHEMA.' +
        'SHAPE_REPRESENTATION_WITH_PARAMETERS' IN TYPEOF(pdr.
        used_representation)))| NOT (SIZEOF(QUERY (it <* impl_rep.
        used_representation.items| (SIZEOF([
        'INTEGRATED_CNC_SCHEMA.MEASURE_REPRESENTATION_ITEM',
        'INTEGRATED_CNC_SCHEMA.PLANE_ANGLE_MEASURE_WITH_UNIT' ] *
        TYPEOF(it)) = 2) AND (it.name = 'root fillet radius')))) <= 1)
        )) = 0))) = 0);
    END_ENTITY; -- 10303-522: aic_machining_feature

ENTITY externally_defined_general_property
    SUBTYPE OF (general_property, externally_defined_item);
    WHERE
        WR1: 'INTEGRATED_CNC_SCHEMA.KNOWN_SOURCE' IN TYPEOF(SELF.source);
        WR2: SELF.source.name = 'ISO 13584 library';
        WR3: SIZEOF(QUERY (aoa <* USEDIN(SELF, 'INTEGRATED_CNC_SCHEMA.' +
        'APPLIED_EXTERNAL_IDENTIFICATION_ASSIGNMENT.ITEMS')| (aoa.
        role.name = 'property version')) = 1;
        WR4: SIZEOF(QUERY (ap <* USEDIN(SELF, 'INTEGRATED_CNC_SCHEMA.' +
        'EXTERNALLY_DEFINED_ITEM_RELATIONSHIP.RELATING_ITEM')| (ap.
        name = 'name scope') AND (
        'INTEGRATED_CNC_SCHEMA.EXTERNALLY_DEFINED_CLASS' IN TYPEOF(ap.
        related_item)))) >= 1;
    END_ENTITY; -- 10303-238: integrated_cnc_schema

ENTITY externally_defined_item;
    item_id : source_item;
    source : external_source;
    END_ENTITY; -- 10303-41: external_reference_schema

ENTITY externally_defined_item_relationship;
    name : label;
    description : OPTIONAL text;
    relating_item : externally_defined_item;
    related_item : externally_defined_item;

```

ISO 10303-238:2007(E)

```

END_ENTITY; -- 10303-41: external_reference_schema

ENTITY externally_defined_representation_with_parameters
  SUBTYPE OF (representation);
  WHERE
    WR1: SIZEOF(USEDIN(SELF, 'INTEGRATED_CNC_SCHEMA.' +
      'APPLIED_CLASSIFICATION_ASSIGNMENT.ITEMS')) = 1;
    WR2: SIZEOF(QUERY (adr <* SELF.items| (
      'INTEGRATED_CNC_SCHEMA.PLACEMENT' IN TYPEOF(adr)))) <= 1;
END_ENTITY; -- 10303-238: integrated_cnc_schema

ENTITY face
  SUPERTYPE OF (ONEOF(face_surface, oriented_face))
  SUBTYPE OF (topological_representation_item);
  bounds : SET [1:?] OF face_bound;
  WHERE
    WR1: NOT mixed_loop_type_set(list_to_set(list_face_loops(SELF)));
    WR2: SIZEOF(QUERY (temp <* bounds| (
      'INTEGRATED_CNC_SCHEMA.FACE_OUTER_BOUND' IN TYPEOF(temp))))
      <= 1;
END_ENTITY; -- 10303-42: topology_schema

ENTITY face_based_surface_model
  SUBTYPE OF (geometric_representation_item);
  fsm_faces : SET [1:?] OF connected_face_set;
END_ENTITY; -- 10303-42: geometric_model_schema

ENTITY face_bound
  SUBTYPE OF (topological_representation_item);
  bound      : loop;
  orientation : BOOLEAN;
END_ENTITY; -- 10303-42: topology_schema

ENTITY face_outer_bound
  SUBTYPE OF (face_bound);
END_ENTITY; -- 10303-42: topology_schema

ENTITY face_shape_representation
  SUBTYPE OF (shape_representation);
  WHERE
    WR1: SIZEOF(SELF.items) >= 1;
    WR2: SIZEOF(QUERY (it <* SELF.items| NOT ((
      'INTEGRATED_CNC_SCHEMA.FACE_SURFACE' IN TYPEOF(it)) OR (
      'INTEGRATED_CNC_SCHEMA.ORIENTED_FACE' IN TYPEOF(it)))))) = 0;
END_ENTITY; -- 10303-522: aic_machining_feature

ENTITY face_surface
  SUBTYPE OF (face, geometric_representation_item);
  face_geometry : surface;
  same_sense    : BOOLEAN;
  -- WHERE
  --   WR1: NOT ('INTEGRATED_CNC_SCHEMA.ORIENTED_SURFACE' IN TYPEOF(
  --     face_geometry));
END_ENTITY; -- 10303-42: topology_schema

```



```

ENTITY faceted_brep
  SUBTYPE OF (manifold_solid_brep);
END_ENTITY; -- 10303-42: geometric_model_schema

ENTITY faceted_brep_shape_representation
  SUBTYPE OF (shape_representation);
  WHERE
    WR1: SIZEOF(QUERY (it <* items| NOT (SIZEOF([
      'INTEGRATED_CNC_SCHEMA.FACETED_BREP',
      'INTEGRATED_CNC_SCHEMA.MAPPED_ITEM',
      'INTEGRATED_CNC_SCHEMA.AXIS2_PLACEMENT_3D' ] * TYPEOF(it)) =
      1))) = 0;
    WR2: SIZEOF(QUERY (it <* items| (SIZEOF([
      'INTEGRATED_CNC_SCHEMA.FACETED_BREP',
      'INTEGRATED_CNC_SCHEMA.MAPPED_ITEM' ] * TYPEOF(it)) = 1))) >
      0;
    WR3: SIZEOF(QUERY (fbrep <* QUERY (it <* items| (
      'INTEGRATED_CNC_SCHEMA.FACETED_BREP' IN TYPEOF(it)))| NOT (
      SIZEOF(QUERY (csh <* msb_shells(fbrep)| NOT (SIZEOF(QUERY (
      fcs <* csh\connected_face_set.cfs_faces| NOT ((
      'INTEGRATED_CNC_SCHEMA.FACE_SURFACE' IN TYPEOF(fcs)) AND ((
      'INTEGRATED_CNC_SCHEMA.PLANE' IN TYPEOF(fcs\face_surface.
      face_geometry)) AND ('INTEGRATED_CNC_SCHEMA.CARTESIAN_POINT'
      IN TYPEOF(fcs\face_surface.face_geometry\elementary_surface.
      position.location)))))) = 0))) = 0))) = 0;
    WR4: SIZEOF(QUERY (fbrep <* QUERY (it <* items| (
      'INTEGRATED_CNC_SCHEMA.FACETED_BREP' IN TYPEOF(it)))| NOT (
      SIZEOF(QUERY (csh <* msb_shells(fbrep)| NOT (SIZEOF(QUERY (
      fcs <* csh\connected_face_set.cfs_faces| NOT (SIZEOF(QUERY (
      bnds <* fcs.bounds| ('INTEGRATED_CNC_SCHEMA.FACE_OUTER_BOUND'
      IN TYPEOF(bnds)))) = 1))) = 0))) = 0))) = 0;
    WR5: SIZEOF(QUERY (msb <* QUERY (it <* items| (
      'INTEGRATED_CNC_SCHEMA.MANIFOLD_SOLID_BREP' IN TYPEOF(it)))|
      ('INTEGRATED_CNC_SCHEMA.ORIENTED_CLOSED_SHELL' IN TYPEOF(msb\
      manifold_solid_brep.outer)))) = 0;
    WR6: SIZEOF(QUERY (brv <* QUERY (it <* items| (
      'INTEGRATED_CNC_SCHEMA.BREP_WITH_VOIDS' IN TYPEOF(it)))| NOT
      (SIZEOF(QUERY (csh <* brv\brep_with_voids.voids| csh\
      oriented_closed_shell.orientation)) = 0))) = 0;
    WR7: SIZEOF(QUERY (mi <* QUERY (it <* items| (
      'INTEGRATED_CNC_SCHEMA.MAPPED_ITEM' IN TYPEOF(it)))| NOT (
      'INTEGRATED_CNC_SCHEMA.FACETED_BREP_SHAPE_REPRESENTATION' IN
      TYPEOF(mi\mapped_item.mapping_source.mapped_representation)))
      ) = 0;
  END_ENTITY; -- 10303-512: aic_faceted_brep

ENTITY facing_turning_operation
  SUBTYPE OF (turning_type_operation);
  WHERE
    WR1: (SELF.description IN ['roughing','finishing']);

    WR2: (verify_optional_action_property (SELF, 'allowance')) AND
      (verify_length_measure_action_property (SELF, 'allowance'));

```

## ISO 10303-238:2007(E)

```
WR3: NOT (SELF.description = 'roughing') OR
      (verify_required_action_property (SELF, 'allowance'));
END_ENTITY; -- 10303-238: integrated_cnc_schema

ENTITY feature_component_definition
  SUBTYPE OF (characterized_object);
  WHERE
    WR1: SIZEOF(QUERY (pd <* USEDIN(SELF,
      'INTEGRATED_CNC_SCHEMA.PROPERTY_DEFINITION.DEFINITION')| NOT
      (SIZEOF(USEDIN(pd,
      'INTEGRATED_CNC_SCHEMA.SHAPE_ASPECT.OF_SHAPE')) = 1))) = 0;
END_ENTITY; -- 10303-522: aic_machining_feature

ENTITY feature_component_relationship
  SUPERTYPE OF (ONEOF(pattern_omit_membership, pattern_offset_membership))
  SUBTYPE OF (shape_aspect_relationship);
  WHERE
    WR1: ((SIZEOF([ 'INTEGRATED_CNC_SCHEMA.COMPOSITE_SHAPE_ASPECT',
      'INTEGRATED_CNC_SCHEMA.REPLICATE_FEATURE',
      'INTEGRATED_CNC_SCHEMA.TRANSITION_FEATURE',
      'INTEGRATED_CNC_SCHEMA.MODIFIED_PATTERN' ] * TYPEOF(SELF.
      relating_shape_aspect)) = 1) OR (
      'INTEGRATED_CNC_SCHEMA.FEATURE_DEFINITION' IN TYPEOF(SELF.
      relating_shape_aspect.of_shape.definition))) OR (
      'INTEGRATED_CNC_SCHEMA.FEATURE_COMPONENT_DEFINITION' IN
      TYPEOF(SELF.relativing_shape_aspect.of_shape.definition));
END_ENTITY; -- 10303-522: aic_machining_feature

ENTITY feature_definition
  SUBTYPE OF (characterized_object);
  WHERE
    WR1: SIZEOF(QUERY (pdr <* get_property_definition_representations(SELF)
      | (
      'INTEGRATED_CNC_SCHEMA.SHAPE_REPRESENTATION_WITH_PARAMETERS'
      IN TYPEOF(pdr.used_representation)))) <= 1;
    WR2: SIZEOF(QUERY (pd <* USEDIN(SELF,
      'INTEGRATED_CNC_SCHEMA.PROPERTY_DEFINITION.DEFINITION')| NOT
      (SIZEOF(QUERY (impl_rep <* QUERY (pdr <* USEDIN(pd,
      'INTEGRATED_CNC_SCHEMA.' +
      'PROPERTY_DEFINITION_REPRESENTATION.DEFINITION')| (
      'INTEGRATED_CNC_SCHEMA.' +
      'SHAPE_REPRESENTATION_WITH_PARAMETERS' IN TYPEOF(pdr.
      used_representation))))| NOT (SIZEOF(QUERY (it <* impl_rep.
      used_representation.items| ('INTEGRATED_CNC_SCHEMA.PLACEMENT'
      IN TYPEOF(it)) AND (it.name = 'orientation')) = 1))) = 0)))
      = 0;
    WR3: SIZEOF([ 'INTEGRATED_CNC_SCHEMA.BOSS',
      'INTEGRATED_CNC_SCHEMA.TURNED_KNURL',
      'INTEGRATED_CNC_SCHEMA.THREAD', 'INTEGRATED_CNC_SCHEMA.GEAR',
      'INTEGRATED_CNC_SCHEMA.MARKING',
      'INTEGRATED_CNC_SCHEMA.RIB_TOP',
      'INTEGRATED_CNC_SCHEMA.ROUND_HOLE',
      'INTEGRATED_CNC_SCHEMA.OUTSIDE_PROFILE',
```

```

'INTEGRATED_CNC_SCHEMA.POCKET',
'INTEGRATED_CNC_SCHEMA.REMOVAL_VOLUME',
'INTEGRATED_CNC_SCHEMA.REVOLVED_PROFILE',
'INTEGRATED_CNC_SCHEMA.OUTER_ROUND',
'INTEGRATED_CNC_SCHEMA.FLAT_FACE',
'INTEGRATED_CNC_SCHEMA.PROTRUSION',
'INTEGRATED_CNC_SCHEMA.ROUNDED_END',
'INTEGRATED_CNC_SCHEMA.SLOT',
'INTEGRATED_CNC_SCHEMA.SPHERICAL_CAP',
'INTEGRATED_CNC_SCHEMA.STEP',
'INTEGRATED_CNC_SCHEMA.COMPOUND_FEATURE',
'INTEGRATED_CNC_SCHEMA.REPLICATE_FEATURE',
'INTEGRATED_CNC_SCHEMA.EXTERNALLY_DEFINED_FEATURE_DEFINITION'
] * TYPEOF(SELF)) <= 1;
WR4: NOT (SIZEOF([ 'INTEGRATED_CNC_SCHEMA.ROUND_HOLE',
'INTEGRATED_CNC_SCHEMA.BOSS',
'INTEGRATED_CNC_SCHEMA.OUTSIDE_PROFILE',
'INTEGRATED_CNC_SCHEMA.REMOVAL_VOLUME',
'INTEGRATED_CNC_SCHEMA.FLAT_FACE',
'INTEGRATED_CNC_SCHEMA.POCKET',
'INTEGRATED_CNC_SCHEMA.PROTRUSION',
'INTEGRATED_CNC_SCHEMA.RIB_TOP',
'INTEGRATED_CNC_SCHEMA.ROUNDED_END',
'INTEGRATED_CNC_SCHEMA.SLOT', 'INTEGRATED_CNC_SCHEMA.STEP' ]
* TYPEOF(SELF)) = 1) OR (SIZEOF(QUERY (pdr <*
get_property_definition_representations(SELF)| (
'INTEGRATED_CNC_SCHEMA.PLANAR_SHAPE_REPRESENTATION' IN TYPEOF
(pdr.used_representation)) AND (pdr.used_representation.name
= 'maximum feature limit')) >= 0);
END_ENTITY; -- 10303-522: aic_machining_feature

ENTITY feature_pattern
SUBTYPE OF (replicate_feature);
WHERE
WR1: SIZEOF(QUERY (pd <* USEDIN(SELF,
'INTEGRATED_CNC_SCHEMA.PROPERTY_DEFINITION.DEFINITION')| (
SIZEOF(QUERY (pdr <* USEDIN(pd, 'INTEGRATED_CNC_SCHEMA.' +
'PROPERTY_DEFINITION_REPRESENTATION.DEFINITION')| (
'INTEGRATED_CNC_SCHEMA.' +
'SHAPE_REPRESENTATION_WITH_PARAMETERS' IN TYPEOF(pdr.
used_representation)) AND (SIZEOF(QUERY (srwp_i <* pdr.
used_representation.items| NOT (
'INTEGRATED_CNC_SCHEMA.PLACEMENT' IN TYPEOF(srwp_i)))) > 0)))
> 0))) = 0;
WR2: SIZEOF(QUERY (pd <* USEDIN(SELF,
'INTEGRATED_CNC_SCHEMA.PROPERTY_DEFINITION.DEFINITION')| NOT
(SIZEOF(QUERY (impl_rep <* QUERY (pdr <* USEDIN(pd,
'INTEGRATED_CNC_SCHEMA.' +
'PROPERTY_DEFINITION_REPRESENTATION.DEFINITION')| (
'INTEGRATED_CNC_SCHEMA.' +
'SHAPE_REPRESENTATION_WITH_PARAMETERS' IN TYPEOF(pdr.
used_representation)))| NOT (SIZEOF(QUERY (it <* impl_rep.
used_representation.items| ('INTEGRATED_CNC_SCHEMA.PLACEMENT'
IN TYPEOF(it)) AND (it.name = 'base feature placement')) >

```

```

1))) = 0))) = 0;
END_ENTITY; -- 10303-522: aic_machining_feature

ENTITY fillet
  SUBTYPE OF (transition_feature);
  WHERE
    WR1: NOT (SELF\shape_aspect.description = 'constant radius') OR (SIZEOF
      (QUERY (pd <* USEDIN(SELF,
        'INTEGRATED_CNC_SCHEMA.PROPERTY_DEFINITION.DEFINITION') | NOT
        (SIZEOF(QUERY (pdr <* USEDIN(pd, 'INTEGRATED_CNC_SCHEMA.' +
        'PROPERTY_DEFINITION_REPRESENTATION.DEFINITION') | (
        'INTEGRATED_CNC_SCHEMA.' +
        'SHAPE_REPRESENTATION_WITH_PARAMETERS' IN TYPEOF(pdr.
        used_representation)))) = 1))) = 0);
    WR2: NOT (SELF\shape_aspect.description = 'constant radius') OR (SIZEOF
      (QUERY (pd <* USEDIN(SELF,
        'INTEGRATED_CNC_SCHEMA.PROPERTY_DEFINITION.DEFINITION') | NOT
        (SIZEOF(QUERY (impl_rep <* QUERY (pdr <* USEDIN(pd,
        'INTEGRATED_CNC_SCHEMA.' +
        'PROPERTY_DEFINITION_REPRESENTATION.DEFINITION') | (
        'INTEGRATED_CNC_SCHEMA.' +
        'SHAPE_REPRESENTATION_WITH_PARAMETERS' IN TYPEOF(pdr.
        used_representation))) | NOT (SIZEOF(impl_rep.
        used_representation.items) >= 1) AND (SIZEOF(impl_rep.
        used_representation.items) <= 3))) = 0))) = 0);
    WR3: NOT (SELF.description = 'constant radius') OR (SIZEOF(QUERY (pd <*
      USEDIN(SELF,
        'INTEGRATED_CNC_SCHEMA.PROPERTY_DEFINITION.DEFINITION') | NOT
        (SIZEOF(QUERY (impl_rep <* QUERY (pdr <* USEDIN(pd,
        'INTEGRATED_CNC_SCHEMA.' +
        'PROPERTY_DEFINITION_REPRESENTATION.DEFINITION') | (
        'INTEGRATED_CNC_SCHEMA.' +
        'SHAPE_REPRESENTATION_WITH_PARAMETERS' IN TYPEOF(pdr.
        used_representation))) | NOT (SIZEOF(QUERY (it <* impl_rep.
        used_representation.items | (SIZEOF([
        'INTEGRATED_CNC_SCHEMA.MEASURE_REPRESENTATION_ITEM',
        'INTEGRATED_CNC_SCHEMA.LENGTH_MEASURE_WITH_UNIT' ] * TYPEOF(
        it)) = 2) AND (it.name = 'radius')))) = 1))) = 0))) = 0);
    WR4: NOT (SELF.description = 'constant radius') OR (SIZEOF(QUERY (pd <*
      USEDIN(SELF,
        'INTEGRATED_CNC_SCHEMA.PROPERTY_DEFINITION.DEFINITION') | NOT
        (SIZEOF(QUERY (impl_rep <* QUERY (pdr <* USEDIN(pd,
        'INTEGRATED_CNC_SCHEMA.' +
        'PROPERTY_DEFINITION_REPRESENTATION.DEFINITION') | (
        'INTEGRATED_CNC_SCHEMA.' +
        'SHAPE_REPRESENTATION_WITH_PARAMETERS' IN TYPEOF(pdr.
        used_representation))) | NOT (SIZEOF(QUERY (it <* impl_rep.
        used_representation.items | (SIZEOF([
        'INTEGRATED_CNC_SCHEMA.MEASURE_REPRESENTATION_ITEM',
        'INTEGRATED_CNC_SCHEMA.LENGTH_MEASURE_WITH_UNIT' ] * TYPEOF(
        it)) = 2) AND (it.name = 'first offset')))) <= 1))) = 0))) = 0);
    WR5: NOT (SELF.description = 'constant radius') OR (SIZEOF(QUERY (pd <*
      USEDIN(SELF,

```

```

'INTEGRATED_CNC_SCHEMA.PROPERTY_DEFINITION.DEFINITION')| NOT
(SIZEOF(QUERY (impl_rep <* QUERY (pdr <* USEDIN(pd,
'INTEGRATED_CNC_SCHEMA.' +
'PROPERTY_DEFINITION_REPRESENTATION.DEFINITION')| (
'INTEGRATED_CNC_SCHEMA.' +
'SHAPE_REPRESENTATION_WITH_PARAMETERS' IN TYPEOF(pdr.
used_representation)))| NOT (SIZEOF(QUERY (it <* impl_rep.
used_representation.items| (SIZEOF([
'INTEGRATED_CNC_SCHEMA.MEASURE_REPRESENTATION_ITEM',
'INTEGRATED_CNC_SCHEMA.LENGTH_MEASURE_WITH_UNIT' ] * TYPEOF(
it)) = 2) AND (it.name = 'second offset')) <= 1))) = 0))) =
0);
WR6: SIZEOF(QUERY (pd <* USEDIN(SELF,
'INTEGRATED_CNC_SCHEMA.PROPERTY_DEFINITION.' + 'DEFINITION')|
NOT (SIZEOF(QUERY (pdr <* USEDIN(pd,
'INTEGRATED_CNC_SCHEMA.' +
'PROPERTY_DEFINITION_REPRESENTATION.DEFINITION')| (
'INTEGRATED_CNC_SCHEMA.FACE_SHAPE_REPRESENTATION' IN TYPEOF(
pdr.used_representation)) AND (pdr.used_representation.name =
'fillet face')))) = 1))) = 0;
WR7: SIZEOF(QUERY (pd <* USEDIN(SELF,
'INTEGRATED_CNC_SCHEMA.PROPERTY_DEFINITION.' + 'DEFINITION')|
NOT (SIZEOF(QUERY (pdr <* USEDIN(pd,
'INTEGRATED_CNC_SCHEMA.' +
'PROPERTY_DEFINITION_REPRESENTATION.DEFINITION')| (
'INTEGRATED_CNC_SCHEMA.FACE_SHAPE_REPRESENTATION' IN TYPEOF(
pdr.used_representation)) AND (pdr.used_representation.name =
'first face shape')))) = 1))) = 0;
WR8: SIZEOF(QUERY (pd <* USEDIN(SELF,
'INTEGRATED_CNC_SCHEMA.PROPERTY_DEFINITION.' + 'DEFINITION')|
NOT (SIZEOF(QUERY (pdr <* USEDIN(pd,
'INTEGRATED_CNC_SCHEMA.' +
'PROPERTY_DEFINITION_REPRESENTATION.DEFINITION')| (
'INTEGRATED_CNC_SCHEMA.FACE_SHAPE_REPRESENTATION' IN TYPEOF(
pdr.used_representation)) AND (pdr.used_representation.name =
'second face shape')))) = 1))) = 0;
END_ENTITY; -- 10303-522: aic_machining_feature

ENTITY flat_face
SUBTYPE OF (feature_definition);
WHERE
WR1: SIZEOF(QUERY (pd <* USEDIN(SELF,
'INTEGRATED_CNC_SCHEMA.PROPERTY_DEFINITION.DEFINITION')| NOT
(SIZEOF(QUERY (pdr <* USEDIN(pd, 'INTEGRATED_CNC_SCHEMA.' +
'PROPERTY_DEFINITION_REPRESENTATION.DEFINITION')| (
'INTEGRATED_CNC_SCHEMA.DIRECTION_SHAPE_REPRESENTATION' IN
TYPEOF(pdr.used_representation)) AND (pdr.used_representation
.name = 'removal direction')))) = 1))) = 0;
WR2: SIZEOF(QUERY (pds <* QUERY (pd <* USEDIN(SELF,
'INTEGRATED_CNC_SCHEMA.PROPERTY_DEFINITION.DEFINITION')| (
'INTEGRATED_CNC_SCHEMA.PRODUCT_DEFINITION_SHAPE' IN TYPEOF(pd
)))| NOT (SIZEOF(QUERY (sa_occ <* USEDIN(pds,
'INTEGRATED_CNC_SCHEMA.SHAPE_ASPECT.OF_SHAPE')| (sa_occ.
description = 'course of travel occurrence') AND (SIZEOF(

```

```

QUERY (sdr <* QUERY (sar <* USEDIN(sa_occ,
'INTEGRATED_CNC_SCHEMA.SHAPE_ASPECT_RELATIONSHIP.' +
'RELATED_SHAPE_ASPECT')| (sar.description =
'path feature component usage') AND (
'INTEGRATED_CNC_SCHEMA.SHAPE_DEFINING_RELATIONSHIP' IN TYPEOF
(sar)))| (('INTEGRATED_CNC_SCHEMA.PATH_FEATURE_COMPONENT' IN
TYPEOF(sdr.relating_shape_aspect)) AND (sdr.
relating_shape_aspect.description = 'linear')) AND (sdr.name
= 'course of travel')) = 1))) = 1))) = 0;
WR3: SIZEOF(QUERY (pds <* QUERY (pd <* USEDIN(SELF,
'INTEGRATED_CNC_SCHEMA.PROPERTY_DEFINITION.DEFINITION')| (
'INTEGRATED_CNC_SCHEMA.PRODUCT_DEFINITION_SHAPE' IN TYPEOF(pd
)))| NOT (SIZEOF(QUERY (sa_occ <* USEDIN(pds,
'INTEGRATED_CNC_SCHEMA.SHAPE_ASPECT.OF_SHAPE')| (sa_occ.
description = 'removal boundary occurrence') AND (SIZEOF(
QUERY (sdr <* QUERY (sar <* USEDIN(sa_occ,
'INTEGRATED_CNC_SCHEMA.SHAPE_ASPECT_RELATIONSHIP.' +
'RELATED_SHAPE_ASPECT')| (sar.description = 'profile usage')
AND ('INTEGRATED_CNC_SCHEMA.SHAPE_DEFINING_RELATIONSHIP' IN
TYPEOF(sar)))| ('INTEGRATED_CNC_SCHEMA.LINEAR_PROFILE' IN
TYPEOF(sdr.relating_shape_aspect)) AND (sdr.name =
'removal boundary')) = 1))) = 1))) = 0;
WR4: SIZEOF(QUERY (pds <* QUERY (pd <* USEDIN(SELF,
'INTEGRATED_CNC_SCHEMA.PROPERTY_DEFINITION.DEFINITION')| (
'INTEGRATED_CNC_SCHEMA.PRODUCT_DEFINITION_SHAPE' IN TYPEOF(pd
)))| NOT (SIZEOF(QUERY (sa_occ <* USEDIN(pds,
'INTEGRATED_CNC_SCHEMA.SHAPE_ASPECT.OF_SHAPE')| (sa_occ.
description = 'enclosed boundary occurrence') AND (SIZEOF(
QUERY (sdr <* QUERY (sar <* USEDIN(sa_occ,
'INTEGRATED_CNC_SCHEMA.SHAPE_ASPECT_RELATIONSHIP.' +
'RELATED_SHAPE_ASPECT')| (sar.description = 'profile usage')
AND ('INTEGRATED_CNC_SCHEMA.SHAPE_DEFINING_RELATIONSHIP' IN
TYPEOF(sar)))| (SIZEOF([
'INTEGRATED_CNC_SCHEMA.CIRCULAR_CLOSED_PROFILE',
'INTEGRATED_CNC_SCHEMA.NGON_CLOSED_PROFILE',
'INTEGRATED_CNC_SCHEMA.RECTANGULAR_CLOSED_PROFILE',
'INTEGRATED_CNC_SCHEMA.CLOSED_PATH_PROFILE' ] * TYPEOF(sdr.
relating_shape_aspect)) = 1) AND (sdr.relating_shape_aspect.
description = 'boundary')) = 1))) <= 1))) = 0;
WR5: SIZEOF(QUERY (pdr <* get_property_definition_representations(SELF)
| ('INTEGRATED_CNC_SCHEMA.PLANAR_SHAPE_REPRESENTATION' IN
TYPEOF(pdr.used_representation)) AND (pdr.used_representation
.name = 'maximum feature limit')) >= 0;
WR6: SIZEOF(QUERY (pds <* USEDIN(SELF,
'INTEGRATED_CNC_SCHEMA.PROPERTY_DEFINITION.DEFINITION')| (
'INTEGRATED_CNC_SCHEMA.PRODUCT_DEFINITION_SHAPE' IN TYPEOF(
pds)) AND (SIZEOF(QUERY (csa <* USEDIN(pds,
'INTEGRATED_CNC_SCHEMA.SHAPE_ASPECT.OF_SHAPE')| ((
'INTEGRATED_CNC_SCHEMA.COMPOSITE_SHAPE_ASPECT' IN TYPEOF(csa)
) AND (csa.name = 'uncut volume')) AND (SIZEOF(QUERY (sar <*
csa.component_relationships| (
'INTEGRATED_CNC_SCHEMA.FEATURE_COMPONENT_RELATIONSHIP' IN
TYPEOF(sar)) AND (SIZEOF([ 'INTEGRATED_CNC_SCHEMA.BOSS',
'INTEGRATED_CNC_SCHEMA.PROTRUSION' ] * TYPEOF(sar.

```

```

related_shape_aspect)) = 1))) = 1))) <= 1))) = 1;
WR7: SIZEOF(QUERY (pd <* USEDIN(SELF,
  'INTEGRATED_CNC_SCHEMA.PROPERTY_DEFINITION.DEFINITION') | NOT
  (SIZEOF(QUERY (impl_rep <* QUERY (pdr <* USEDIN(pd,
  'INTEGRATED_CNC_SCHEMA.' +
  'PROPERTY_DEFINITION_REPRESENTATION.DEFINITION') | (
  'INTEGRATED_CNC_SCHEMA.' +
  'SHAPE_REPRESENTATION_WITH_PARAMETERS' IN TYPEOF(pdr.
  used_representation))) | NOT (SIZEOF(QUERY (it <* impl_rep.
  used_representation.items | (SIZEOF([
  'INTEGRATED_CNC_SCHEMA.MEASURE_REPRESENTATION_ITEM',
  'INTEGRATED_CNC_SCHEMA.LENGTH_MEASURE_WITH_UNIT' ] * TYPEOF(
  it)) = 2) AND (it.name = 'removal depth')) <= 1))) = 0))) =
0;
END_ENTITY; -- 10303-522: aic_machining_feature

ENTITY flatness_tolerance
  SUBTYPE OF (geometric_tolerance);
  WHERE
    WR1: NOT ('INTEGRATED_CNC_SCHEMA.' +
      'GEOMETRIC_TOLERANCE_WITH_DATUM_REFERENCE' IN TYPEOF(SELF));
END_ENTITY; -- 10303-519: aic_geometric_tolerances

ENTITY founded_item;
END_ENTITY; -- 10303-43: representation_schema

ENTITY freeform_milling_operation
  SUBTYPE OF (milling_type_operation);
  WHERE
    WR1: ((verify_optional_relating_amr_with_name (SELF, 'machining',
      ['INTEGRATED_CNC_SCHEMA.MACHINING_STRATEGY_RELATIONSHIP'])) AND
      (verify_related_type_for_amr_with_name (SELF, 'machining',
      ['INTEGRATED_CNC_SCHEMA.MACHINING_STRATEGY_RELATIONSHIP'],
      ['INTEGRATED_CNC_SCHEMA.FREEFORM_MILLING_STRATEGY']))
    );
END_ENTITY; -- 10303-238: integrated_cnc_schema

ENTITY freeform_milling_strategy
  SUBTYPE OF (milling_type_strategy);
  WHERE
    WR1: NOT (SELF.description IN ['leading line', 'plane cutter contact',
      'plane cutter location', 'uv']) OR
      ((verify_required_action_property (SELF, 'pathmode')) AND
      (verify_enumeration_action_property (SELF, 'pathmode',
      ['forward', 'zigzag'])) AND
      (verify_required_action_property (SELF, 'cutmode')) AND
      (verify_enumeration_action_property (SELF, 'cutmode',
      ['climb', 'conventional'])) AND
      (verify_required_action_property (SELF, 'milling tolerances')) AND
      (verify_rep_type_for_action_property (SELF, 'milling tolerances',
      ['INTEGRATED_CNC_SCHEMA.FREEFORM_MILLING_TOLERANCE_REPRESENTATION']))
AND

```

```

        (verify_optional_action_property      (SELF, 'stepover length')) AND
        (verify_length_measure_action_property (SELF, 'stepover length')) );

WR2: NOT (SELF.description = 'leading line') OR
        ((verify_required_action_property      (SELF, 'leading line')) AND
         (verify_rep_item_for_action_property  (SELF, 'leading line',
         ['INTEGRATED_CNC_SCHEMA.BOUNDED_CURVE']))) );

WR3: NOT (SELF.description IN ['plane cutter contact', 'plane cutter
location']) OR
        ((verify_required_action_property      (SELF, 'plane normal')) AND
         (verify_rep_item_for_action_property  (SELF, 'plane normal',
         ['INTEGRATED_CNC_SCHEMA.DIRECTION']))) );

WR4: NOT (SELF.description = 'uv') OR
        ((verify_required_action_property      (SELF, 'forward direction')) AND
         (verify_rep_item_for_action_property  (SELF, 'forward direction',
         ['INTEGRATED_CNC_SCHEMA.DIRECTION']))) AND

        (verify_required_action_property      (SELF, 'sideward direction')) AND
        (verify_rep_item_for_action_property  (SELF, 'sideward direction',
        ['INTEGRATED_CNC_SCHEMA.DIRECTION']))) );
END_ENTITY; -- 10303-238: integrated_cnc_schema

ENTITY freeform_milling_tolerance_representation
  SUBTYPE OF (representation);
  WHERE
    WR1: (verify_required_rep_item      (SELF, 'chordal tolerance')) AND
          (verify_length_measure_rep_item (SELF, 'chordal tolerance'));

    WR2: (verify_required_rep_item      (SELF, 'scallop height')) AND
          (verify_length_measure_rep_item (SELF, 'scallop height'));
END_ENTITY; -- 10303-238: integrated_cnc_schema

ENTITY functionally_defined_transformation;
  name      : label;
  description : OPTIONAL text;
END_ENTITY; -- 10303-43: representation_schema

ENTITY gear
  SUBTYPE OF (feature_definition);
  WHERE
    WR1: SIZEOF(QUERY (pd <* USEDIN(SELF,
      'INTEGRATED_CNC_SCHEMA.PROPERTY_DEFINITION.DEFINITION') | (
      SIZEOF(QUERY (pdr <* USEDIN(pd,
      'INTEGRATED_CNC_SCHEMA.PROPERTY_DEFINITION_REPRESENTATION.DEFINITION'
      ) | ((
      'INTEGRATED_CNC_SCHEMA.SHAPE_REPRESENTATION_WITH_PARAMETERS'
      IN TYPEOF(pdr.used_representation)) AND (10 <= SIZEOF(pdr.
      used_representation.items))) AND (SIZEOF(pdr.
      used_representation.items) <= 13))) = 1))) = 1;
    WR2: NOT (SELF\characterized_object.description IN [

```



```

'straight bevel gear', 'helical bevel gear', 'spur gear',
'helical gear' ] ) OR (SIZEOF(QUERY (pd <* USEDIN(SELF,
'INTEGRATED_CNC_SCHEMA.PROPERTY_DEFINITION.DEFINITION') | NOT
(SIZEOF(QUERY (impl_rep <* QUERY (pdr <* USEDIN(pd,
'INTEGRATED_CNC_SCHEMA.PROPERTY_DEFINITION_REPRESENTATION.DEFINITION'
)| (
'INTEGRATED_CNC_SCHEMA.SHAPE_REPRESENTATION_WITH_PARAMETERS'
IN TYPEOF(pdr.used_representation))) | NOT (SIZEOF(QUERY (it
<* impl_rep.used_representation.items | (SIZEOF([
'INTEGRATED_CNC_SCHEMA.MEASURE_REPRESENTATION_ITEM',
'INTEGRATED_CNC_SCHEMA.RATIO_MEASURE_WITH_UNIT' ] * TYPEOF(it
)) = 2) AND (it.name = 'number of teeth'))) = 1))) = 0))) = 0
);
WR3: NOT (SELF\characterized_object.description IN [
'straight bevel gear', 'helical bevel gear', 'spur gear',
'helical gear' ] ) OR (SIZEOF(QUERY (pd <* USEDIN(SELF,
'INTEGRATED_CNC_SCHEMA.PROPERTY_DEFINITION.DEFINITION') | NOT
(SIZEOF(QUERY (impl_rep <* QUERY (pdr <* USEDIN(pd,
'INTEGRATED_CNC_SCHEMA.PROPERTY_DEFINITION_REPRESENTATION.DEFINITION'
)| (
'INTEGRATED_CNC_SCHEMA.SHAPE_REPRESENTATION_WITH_PARAMETERS'
IN TYPEOF(pdr.used_representation))) | NOT (SIZEOF(QUERY (it
<* impl_rep.used_representation.items | (SIZEOF([
'INTEGRATED_CNC_SCHEMA.MEASURE_REPRESENTATION_ITEM',
'INTEGRATED_CNC_SCHEMA.PLANE_ANGLE_MEASURE_WITH_UNIT' ] *
TYPEOF(it)) = 2) AND (it.name = 'reference pressure angle')))
= 1))) = 0))) = 0);
WR4: NOT (SELF\characterized_object.description IN [
'straight bevel gear', 'helical bevel gear', 'spur gear',
'helical gear' ] ) OR (SIZEOF(QUERY (pd <* USEDIN(SELF,
'INTEGRATED_CNC_SCHEMA.PROPERTY_DEFINITION.DEFINITION') | NOT
(SIZEOF(QUERY (impl_rep <* QUERY (pdr <* USEDIN(pd,
'INTEGRATED_CNC_SCHEMA.PROPERTY_DEFINITION_REPRESENTATION.DEFINITION'
)| (
'INTEGRATED_CNC_SCHEMA.SHAPE_REPRESENTATION_WITH_PARAMETERS'
IN TYPEOF(pdr.used_representation))) | NOT (SIZEOF(QUERY (it
<* impl_rep.used_representation.items | (SIZEOF([
'INTEGRATED_CNC_SCHEMA.MEASURE_REPRESENTATION_ITEM',
'INTEGRATED_CNC_SCHEMA.LENGTH_MEASURE_WITH_UNIT' ] * TYPEOF(
it)) = 2) AND (it.name = 'rake shift factor'))) = 1))) = 0)))
= 0);
WR5: NOT (SELF\characterized_object.description IN [
'straight bevel gear', 'helical bevel gear', 'spur gear',
'helical gear' ] ) OR (SIZEOF(QUERY (pd <* USEDIN(SELF,
'INTEGRATED_CNC_SCHEMA.PROPERTY_DEFINITION.DEFINITION') | NOT
(SIZEOF(QUERY (impl_rep <* QUERY (pdr <* USEDIN(pd,
'INTEGRATED_CNC_SCHEMA.PROPERTY_DEFINITION_REPRESENTATION.DEFINITION'
)| (
'INTEGRATED_CNC_SCHEMA.SHAPE_REPRESENTATION_WITH_PARAMETERS'
IN TYPEOF(pdr.used_representation))) | NOT (SIZEOF(QUERY (it

```

```

    <* impl_rep.used_representation.items| (SIZEOF([
      'INTEGRATED_CNC_SCHEMA.MEASURE_REPRESENTATION_ITEM',
      'INTEGRATED_CNC_SCHEMA.LENGTH_MEASURE_WITH_UNIT' ] * TYPEOF(
        it)) = 2) AND (it.name = 'nominal tooth depth')) = 1))) = 0)
  )) = 0);
WR6: NOT (SELF\characterized_object.description IN [
  'straight bevel gear', 'helical bevel gear', 'spur gear',
  'helical gear' ] ) OR (SIZEOF(QUERY (pd <* USEDIN(SELF,
  'INTEGRATED_CNC_SCHEMA.PROPERTY_DEFINITION.DEFINITION')| NOT
  (SIZEOF(QUERY (impl_rep <* QUERY (pdr <* USEDIN(pd,
  'INTEGRATED_CNC_SCHEMA.PROPERTY_DEFINITION_REPRESENTATION.DEFINITION'
  )| (
  'INTEGRATED_CNC_SCHEMA.SHAPE_REPRESENTATION_WITH_PARAMETERS'
  IN TYPEOF(pdr.used_representation)))| NOT (SIZEOF(QUERY (it
  <* impl_rep.used_representation.items| (SIZEOF([
  'INTEGRATED_CNC_SCHEMA.MEASURE_REPRESENTATION_ITEM',
  'INTEGRATED_CNC_SCHEMA.LENGTH_MEASURE_WITH_UNIT' ] * TYPEOF(
  it)) = 2) AND (it.name = 'face width')) = 1))) = 0))) = 0));
WR7: NOT (SELF\characterized_object.description IN [
  'straight bevel gear', 'helical bevel gear', 'spur gear',
  'helical gear' ] ) OR (SIZEOF(QUERY (pd <* USEDIN(SELF,
  'INTEGRATED_CNC_SCHEMA.PROPERTY_DEFINITION.DEFINITION')| NOT
  (SIZEOF(QUERY (impl_rep <* QUERY (pdr <* USEDIN(pd,
  'INTEGRATED_CNC_SCHEMA.PROPERTY_DEFINITION_REPRESENTATION.DEFINITION'
  )| (
  'INTEGRATED_CNC_SCHEMA.SHAPE_REPRESENTATION_WITH_PARAMETERS'
  IN TYPEOF(pdr.used_representation)))| NOT (SIZEOF(QUERY (it
  <* impl_rep.used_representation.items| (SIZEOF([
  'INTEGRATED_CNC_SCHEMA.MEASURE_REPRESENTATION_ITEM',
  'INTEGRATED_CNC_SCHEMA.LENGTH_MEASURE_WITH_UNIT' ] * TYPEOF(
  it)) = 2) AND (it.name = 'tip diameter')) = 1))) = 0))) = 0)
  ;
WR8: NOT (SELF\characterized_object.description IN [
  'straight bevel gear', 'helical bevel gear', 'spur gear',
  'helical gear' ] ) OR (SIZEOF(QUERY (pd <* USEDIN(SELF,
  'INTEGRATED_CNC_SCHEMA.PROPERTY_DEFINITION.DEFINITION')| NOT
  (SIZEOF(QUERY (impl_rep <* QUERY (pdr <* USEDIN(pd,
  'INTEGRATED_CNC_SCHEMA.PROPERTY_DEFINITION_REPRESENTATION.DEFINITION'
  )| (
  'INTEGRATED_CNC_SCHEMA.SHAPE_REPRESENTATION_WITH_PARAMETERS'
  IN TYPEOF(pdr.used_representation)))| NOT (SIZEOF(QUERY (it
  <* impl_rep.used_representation.items| ((
  'INTEGRATED_CNC_SCHEMA.DESRIPTIVE_REPRESENTATION_ITEM' IN
  TYPEOF(it)) AND (it.name = 'module or diametral pitch')) AND
  ((it.description = 'module') OR (it.description =
  'diametral pitch')))) = 1))) = 0))) = 0);
WR9: NOT (SELF\characterized_object.description IN [
  'straight bevel gear', 'helical bevel gear', 'spur gear',
  'helical gear' ] ) OR (SIZEOF(QUERY (pd <* USEDIN(SELF,
  'INTEGRATED_CNC_SCHEMA.PROPERTY_DEFINITION.DEFINITION')| NOT
  (SIZEOF(QUERY (impl_rep <* QUERY (pdr <* USEDIN(pd,

```

```

'INTEGRATED_CNC_SCHEMA.PROPERTY_DEFINITION_REPRESENTATION.DEFINITION'
)| (
  'INTEGRATED_CNC_SCHEMA.SHAPE_REPRESENTATION_WITH_PARAMETERS'
  IN TYPEOF(pdr.used_representation)))| NOT (SIZEOF(QUERY (it
  <* impl_rep.used_representation.items| ((
  'INTEGRATED_CNC_SCHEMA.DESCRPTIVE_REPRESENTATION_ITEM' IN
  TYPEOF(it)) AND (it.name = 'internal or external gear')) AND
  ((it.description = 'internal') OR (it.description =
  'external')))) = 1))) = 0))) = 0);
WR10: NOT (SELF\characterized_object.description IN [
  'straight bevel gear', 'helical bevel gear', 'spur gear',
  'helical gear' ] ) OR (SIZEOF(QUERY (pd <* USEDIN(SELF,
  'INTEGRATED_CNC_SCHEMA.PROPERTY_DEFINITION.DEFINITION')| NOT
  (SIZEOF(QUERY (impl_rep <* QUERY (pdr <* USEDIN(pd,
'INTEGRATED_CNC_SCHEMA.PROPERTY_DEFINITION_REPRESENTATION.DEFINITION'
)| (
  'INTEGRATED_CNC_SCHEMA.SHAPE_REPRESENTATION_WITH_PARAMETERS'
  IN TYPEOF(pdr.used_representation)))| NOT (SIZEOF(QUERY (it
  <* impl_rep.used_representation.items| (SIZEOF([
  'INTEGRATED_CNC_SCHEMA.MEASURE_REPRESENTATION_ITEM',
  'INTEGRATED_CNC_SCHEMA.LENGTH_MEASURE_WITH_UNIT' ] * TYPEOF(
  it)) = 2) AND (it.name = 'normal attribute')) = 1))) = 0)))
  = 0);
WR11: NOT (SELF\characterized_object.description IN [
  'straight bevel gear', 'helical bevel gear', 'spur gear',
  'helical gear' ] ) OR (SIZEOF(QUERY (pd <* USEDIN(SELF,
  'INTEGRATED_CNC_SCHEMA.PROPERTY_DEFINITION.DEFINITION')| NOT
  (SIZEOF(QUERY (impl_rep <* QUERY (pdr <* USEDIN(pd,
'INTEGRATED_CNC_SCHEMA.PROPERTY_DEFINITION_REPRESENTATION.DEFINITION'
)| (
  'INTEGRATED_CNC_SCHEMA.SHAPE_REPRESENTATION_WITH_PARAMETERS'
  IN TYPEOF(pdr.used_representation)))| NOT (SIZEOF(QUERY (it
  <* impl_rep.used_representation.items| (SIZEOF([
  'INTEGRATED_CNC_SCHEMA.MEASURE_REPRESENTATION_ITEM',
  'INTEGRATED_CNC_SCHEMA.LENGTH_MEASURE_WITH_UNIT' ] * TYPEOF(
  it)) = 2) AND (it.name = 'root fillet radius')) <= 1))) = 0)
  )) = 0);
WR12: NOT (SELF\characterized_object.description IN [ 'helix gear',
  'helical bevel gear' ] ) OR (SIZEOF(QUERY (pd <* USEDIN(SELF,
  'INTEGRATED_CNC_SCHEMA.PROPERTY_DEFINITION.DEFINITION')| NOT
  (SIZEOF(QUERY (impl_rep <* QUERY (pdr <* USEDIN(pd,
'INTEGRATED_CNC_SCHEMA.PROPERTY_DEFINITION_REPRESENTATION.DEFINITION'
)| (
  'INTEGRATED_CNC_SCHEMA.SHAPE_REPRESENTATION_WITH_PARAMETERS'
  IN TYPEOF(pdr.used_representation)))| NOT (SIZEOF(QUERY (it
  <* impl_rep.used_representation.items| (SIZEOF([
  'INTEGRATED_CNC_SCHEMA.MEASURE_REPRESENTATION_ITEM',
  'INTEGRATED_CNC_SCHEMA.PLANE_ANGLE_MEASURE_WITH_UNIT' ] *
  TYPEOF(it)) = 2) AND (it.name = 'reference helix angle')) =
  1))) = 0))) = 0);

```

```

WR13: NOT (SELF\characterized_object.description IN [ 'helix gear',
'helical bevel gear' ]) OR (SIZEOF(QUERY (pd <* USEDIN(SELF,
'INTEGRATED_CNC_SCHEMA.PROPERTY_DEFINITION.DEFINITION')| NOT
(SIZEOF(QUERY (impl_rep <* QUERY (pdr <* USEDIN(pd,
'INTEGRATED_CNC_SCHEMA.PROPERTY_DEFINITION_REPRESENTATION.DEFINITION'
)| (
'INTEGRATED_CNC_SCHEMA.SHAPE_REPRESENTATION_WITH_PARAMETERS'
IN TYPEOF(pdr.used_representation)))| NOT (SIZEOF(QUERY (it
<* impl_rep.used_representation.items| ((
'INTEGRATED_CNC_SCHEMA.DESRIPTIVE_REPRESENTATION_ITEM' IN
TYPEOF(it)) AND (it.name = 'gear tooth')) AND ((it.
description = 'left hand tooth') OR (it.description =
'right hand tooth')))) = 1))) = 0))) = 0);
WR14: NOT (SELF\characterized_object.description IN [
'straight bevel gear', 'helical bevel gear' ]) OR (SIZEOF(
QUERY (pd <* USEDIN(SELF,
'INTEGRATED_CNC_SCHEMA.PROPERTY_DEFINITION.DEFINITION')| NOT
(SIZEOF(QUERY (impl_rep <* QUERY (pdr <* USEDIN(pd,
'INTEGRATED_CNC_SCHEMA.PROPERTY_DEFINITION_REPRESENTATION.DEFINITION'
)| (
'INTEGRATED_CNC_SCHEMA.SHAPE_REPRESENTATION_WITH_PARAMETERS'
IN TYPEOF(pdr.used_representation)))| NOT (SIZEOF(QUERY (it
<* impl_rep.used_representation.items| (SIZEOF([
'INTEGRATED_CNC_SCHEMA.MEASURE_REPRESENTATION_ITEM',
'INTEGRATED_CNC_SCHEMA.PLANE_ANGLE_MEASURE_WITH_UNIT' ] *
TYPEOF(it)) = 2) AND (it.name = 'tip angle')) = 1))) = 0)))
= 0);
WR15: NOT (SELF\characterized_object.description IN [
'straight bevel gear', 'helical bevel gear' ]) OR (SIZEOF(
QUERY (pd <* USEDIN(SELF,
'INTEGRATED_CNC_SCHEMA.PROPERTY_DEFINITION.DEFINITION')| NOT
(SIZEOF(QUERY (impl_rep <* QUERY (pdr <* USEDIN(pd,
'INTEGRATED_CNC_SCHEMA.PROPERTY_DEFINITION_REPRESENTATION.DEFINITION'
)| (
'INTEGRATED_CNC_SCHEMA.SHAPE_REPRESENTATION_WITH_PARAMETERS'
IN TYPEOF(pdr.used_representation)))| NOT (SIZEOF(QUERY (it
<* impl_rep.used_representation.items| (SIZEOF([
'INTEGRATED_CNC_SCHEMA.MEASURE_REPRESENTATION_ITEM',
'INTEGRATED_CNC_SCHEMA.PLANE_ANGLE_MEASURE_WITH_UNIT' ] *
TYPEOF(it)) = 2) AND (it.name = 'root angle')) = 1))) = 0)))
= 0);
WR16: SIZEOF(QUERY (pds <* QUERY (pd <* USEDIN(SELF,
'INTEGRATED_CNC_SCHEMA.PROPERTY_DEFINITION.DEFINITION')| (
'INTEGRATED_CNC_SCHEMA.PRODUCT_DEFINITION_SHAPE' IN TYPEOF(pd
)))| NOT (SIZEOF(QUERY (sa_occ <* USEDIN(pds,
'INTEGRATED_CNC_SCHEMA.SHAPE_ASPECT.OF_SHAPE')| (SIZEOF(QUERY
(sdr <* QUERY (sar <* USEDIN(sa_occ,
'INTEGRATED_CNC_SCHEMA.SHAPE_ASPECT_RELATIONSHIP.RELATED_SHAPE_ASPECT'
)| (sar.description = 'applied shape') AND (
'INTEGRATED_CNC_SCHEMA.SHAPE_DEFINING_RELATIONSHIP' IN TYPEOF

```

```

        (sar)))| ('INTEGRATED_CNC_SCHEMA.SHAPE_ASPECT' IN TYPEOF(sdr.
        relating_shape_aspect)))) = 1))) = 1))) = 0;
END_ENTITY; -- 10303-522: aic_machining_feature

ENTITY general_property;
    id          : identifier;
    name        : label;
    description : OPTIONAL text;
END_ENTITY; -- 10303-41: product_property_definition_schema

ENTITY general_property_association;
    name          : label;
    description   : OPTIONAL text;
    base_definition : general_property;
    derived_definition : derived_property_select;
    WHERE
        WR1: SIZEOF(USEDIN(derived_definition, 'INTEGRATED_CNC_SCHEMA.' +
            'GENERAL_PROPERTY_ASSOCIATION.' + 'DERIVED_DEFINITION')) = 1;
        WR2: derived_definition.name = base_definition.name;
END_ENTITY; -- 10303-41: product_property_definition_schema

ENTITY generic_expression
    ABSTRACT SUPERTYPE OF (ONEOF(simple_generic_expression,
        unary_generic_expression, binary_generic_expression,
        multiple_arity_generic_expression));
    WHERE
        WR1: is_acyclic(SELF);
END_ENTITY; -- 13584-20: iso13584_generic_expressions_schema

ENTITY generic_literal
    ABSTRACT SUPERTYPE
    SUBTYPE OF (simple_generic_expression);
END_ENTITY; -- 13584-20: iso13584_generic_expressions_schema

ENTITY generic_variable
    ABSTRACT SUPERTYPE
    SUBTYPE OF (simple_generic_expression);
    INVERSE
        interpretation : environment FOR syntactic_representation;
END_ENTITY; -- 13584-20: iso13584_generic_expressions_schema

ENTITY geometric_alignment
    SUBTYPE OF (derived_shape_aspect);
    WHERE
        WR1: SIZEOF(SELF\derived_shape_aspect.deriving_relationships) > 1;
END_ENTITY; -- 10303-47: shape_aspect_definition_schema

ENTITY geometric_curve_set
    SUBTYPE OF (geometric_set);
    WHERE
        WR1: SIZEOF(QUERY (temp <* SELF\geometric_set.elements| (
            'INTEGRATED_CNC_SCHEMA.SURFACE' IN TYPEOF(temp)))) = 0;
END_ENTITY; -- 10303-42: geometric_model_schema

```

ISO 10303-238:2007(E)

```

ENTITY geometric_intersection
  SUBTYPE OF (derived_shape_aspect);
  WHERE
    WR1: SIZEOF(SELF\derived_shape_aspect.deriving_relationships) > 1;
END_ENTITY; -- 10303-47: shape_aspect_definition_schema

ENTITY geometric_representation_context
  SUBTYPE OF (representation_context);
  coordinate_space_dimension : dimension_count;
END_ENTITY; -- 10303-42: geometry_schema

ENTITY geometric_representation_item
  SUPERTYPE OF (ONEOF(point, direction, vector, placement,
    cartesian_transformation_operator, curve, surface, edge_curve,
    face_surface, poly_loop, vertex_point, solid_model,
    right_circular_cylinder, block, shell_based_surface_model,
    face_based_surface_model, shell_based_wireframe_model,
    edge_based_wireframe_model, geometric_set))
  SUBTYPE OF (representation_item);
  DERIVE
    dim : dimension_count := dimension_of(SELF);
  WHERE
    WR1: SIZEOF(QUERY (using_rep <* using_representations(SELF)| NOT (
      'INTEGRATED_CNC_SCHEMA.GEOMETRIC_REPRESENTATION_CONTEXT' IN
      TYPEOF(using_rep.context_of_items)))) = 0;
END_ENTITY; -- 10303-42: geometry_schema

ENTITY geometric_set
  SUPERTYPE OF (geometric_curve_set)
  SUBTYPE OF (geometric_representation_item);
  elements : SET [1:?] OF geometric_set_select;
END_ENTITY; -- 10303-42: geometric_model_schema

ENTITY geometric_tolerance;
  name : label;
  description : text;
  magnitude : measure_with_unit;
  toleranced_shape_aspect : shape_aspect;
  WHERE
    WR1: ('NUMBER' IN TYPEOF(magnitude\measure_with_unit.value_component))
      AND (magnitude\measure_with_unit.value_component >= 0.0);
END_ENTITY; -- 10303-47: shape_tolerance_schema

ENTITY geometric_tolerance_relationship;
  name : label;
  description : text;
  relating_geometric_tolerance : geometric_tolerance;
  related_geometric_tolerance : geometric_tolerance;
END_ENTITY; -- 10303-47: shape_tolerance_schema

ENTITY geometric_tolerance_with_datum_reference
  SUBTYPE OF (geometric_tolerance);
  datum_system : SET [1:?] OF datum_reference;
END_ENTITY; -- 10303-47: shape_tolerance_schema

```

```

ENTITY geometric_tolerance_with_defined_unit
  SUBTYPE OF (geometric_tolerance);
  unit_size : measure_with_unit;
  WHERE
    WR1: ('NUMBER' IN TYPEOF(unit_size\measure_with_unit.value_component))
          AND (unit_size\measure_with_unit.value_component > 0.0);
END_ENTITY; -- 10303-47: shape_tolerance_schema

```

```

ENTITY geometrically_bounded_surface_shape_representation
  SUBTYPE OF (shape_representation);
  WHERE
    WR1: SIZEOF(QUERY (it <* SELF.items| NOT (SIZEOF([
      'INTEGRATED_CNC_SCHEMA.GEOMETRIC_SET',
      'INTEGRATED_CNC_SCHEMA.MAPPED_ITEM',
      'INTEGRATED_CNC_SCHEMA.AXIS2_PLACEMENT_3D' ] * TYPEOF(it)) =
      1))) = 0;
    WR2: SIZEOF(QUERY (it <* SELF.items| (SIZEOF([
      'INTEGRATED_CNC_SCHEMA.GEOMETRIC_SET',
      'INTEGRATED_CNC_SCHEMA.MAPPED_ITEM' ] * TYPEOF(it)) = 1))) >
      0;
    WR3: SIZEOF(QUERY (mi <* QUERY (it <* SELF.items| (
      'INTEGRATED_CNC_SCHEMA.MAPPED_ITEM' IN TYPEOF(it)))| NOT ((
      'INTEGRATED_CNC_SCHEMA.' +
      'GEOMETRICALLY_BOUNDED_SURFACE_SHAPE_REPRESENTATION' IN
      TYPEOF(mi\mapped_item.mapping_source.mapped_representation))
      AND (SIZEOF(QUERY (mr_it <* mi\mapped_item.mapping_source.
      mapped_representation.items| (
      'INTEGRATED_CNC_SCHEMA.GEOMETRIC_SET' IN TYPEOF(mr_it)))) > 0
      ))) = 0;
    WR4: SIZEOF(QUERY (gs <* QUERY (it <* SELF.items| (
      'INTEGRATED_CNC_SCHEMA.GEOMETRIC_SET' IN TYPEOF(it)))| NOT (
      SIZEOF(QUERY (pnt <* QUERY (gsel <* gs\geometric_set.elements
      | ('INTEGRATED_CNC_SCHEMA.POINT' IN TYPEOF(gsel)))| NOT
      gbsf_check_point(pnt))) = 0))) = 0;
    WR5: SIZEOF(QUERY (gs <* QUERY (it <* SELF.items| (
      'INTEGRATED_CNC_SCHEMA.GEOMETRIC_SET' IN TYPEOF(it)))| NOT (
      SIZEOF(QUERY (cv <* QUERY (gsel <* gs\geometric_set.elements|
      ('INTEGRATED_CNC_SCHEMA.CURVE' IN TYPEOF(gsel)))| NOT
      gbsf_check_curve(cv))) = 0))) = 0;
    WR6: SIZEOF(QUERY (gs <* QUERY (it <* SELF.items| (
      'INTEGRATED_CNC_SCHEMA.GEOMETRIC_SET' IN TYPEOF(it)))| NOT (
      SIZEOF(QUERY (sf <* QUERY (gsel <* gs\geometric_set.elements|
      ('INTEGRATED_CNC_SCHEMA.SURFACE' IN TYPEOF(gsel)))| NOT
      gbsf_check_surface(sf))) = 0))) = 0;
    WR7: SIZEOF(QUERY (gs <* QUERY (it <* SELF.items| (
      'INTEGRATED_CNC_SCHEMA.GEOMETRIC_SET' IN TYPEOF(it)))| (
      SIZEOF(QUERY (gsel <* gs\geometric_set.elements| (
      'INTEGRATED_CNC_SCHEMA.SURFACE' IN TYPEOF(gsel)))) > 0))) > 0
      ;
END_ENTITY; -- 10303-507: aic_geometrically_bounded_surface

```

```

ENTITY geometrically_bounded_wireframe_shape_representation
  SUBTYPE OF (shape_representation);

```

```

WHERE
  WR1: SIZEOF(QUERY (it <* SELF.items| NOT (SIZEOF(TYPEOF(it) * [
    'INTEGRATED_CNC_SCHEMA.GEOMETRIC_CURVE_SET',
    'INTEGRATED_CNC_SCHEMA.AXIS2_PLACEMENT_3D',
    'INTEGRATED_CNC_SCHEMA.MAPPED_ITEM' ])) = 1))) = 0;
  WR2: SIZEOF(QUERY (it <* SELF.items| (SIZEOF(TYPEOF(it) * [
    'INTEGRATED_CNC_SCHEMA.GEOMETRIC_CURVE_SET',
    'INTEGRATED_CNC_SCHEMA.MAPPED_ITEM' ])) = 1))) >= 1;
  WR3: SIZEOF(QUERY (gcs <* QUERY (it <* SELF.items| (
    'INTEGRATED_CNC_SCHEMA.GEOMETRIC_CURVE_SET' IN TYPEOF(it)))|
    NOT (SIZEOF(QUERY (crv <* QUERY (elem <* gcs\geometric_set.
    elements| ('INTEGRATED_CNC_SCHEMA.CURVE' IN TYPEOF(elem)))|
    NOT valid_geometrically_bounded_wf_curve(crv))) = 0))) = 0;
  WR4: SIZEOF(QUERY (gcs <* QUERY (it <* SELF.items| (
    'INTEGRATED_CNC_SCHEMA.GEOMETRIC_CURVE_SET' IN TYPEOF(it)))|
    NOT (SIZEOF(QUERY (pnts <* QUERY (elem <* gcs\geometric_set.
    elements| ('INTEGRATED_CNC_SCHEMA.POINT' IN TYPEOF(elem)))|
    NOT valid_geometrically_bounded_wf_point(pnts))) = 0))) = 0;
  WR5: SIZEOF(QUERY (gcs <* QUERY (it <* SELF.items| (
    'INTEGRATED_CNC_SCHEMA.GEOMETRIC_CURVE_SET' IN TYPEOF(it)))|
    NOT (SIZEOF(QUERY (cnc <* QUERY (elem <* gcs\geometric_set.
    elements| ('INTEGRATED_CNC_SCHEMA.CONIC' IN TYPEOF(elem)))|
    NOT ('INTEGRATED_CNC_SCHEMA.AXIS2_PLACEMENT_3D' IN TYPEOF(cnc
    \conic.position)))) = 0))) = 0;
  WR6: SIZEOF(QUERY (gcs <* QUERY (it <* SELF.items| (
    'INTEGRATED_CNC_SCHEMA.GEOMETRIC_CURVE_SET' IN TYPEOF(it)))|
    NOT (SIZEOF(QUERY (pline <* QUERY (elem <* gcs\geometric_set.
    elements| ('INTEGRATED_CNC_SCHEMA.POLYLINE' IN TYPEOF(elem))
    | NOT (SIZEOF(pline\polyline.points) > 2)))) = 0))) = 0;
  WR7: SIZEOF(QUERY (mi <* QUERY (it <* SELF.items| (
    'INTEGRATED_CNC_SCHEMA.MAPPED_ITEM' IN TYPEOF(it)))| NOT (
    'INTEGRATED_CNC_SCHEMA.' +
    'GEOMETRICALLY_BOUNDED_WIREFRAME_SHAPE_REPRESENTATION' IN
    TYPEOF(mi\mapped_item.mapping_source.mapped_representation)))
    ) = 0;
END_ENTITY; -- 10303-510: aic_geometrically_bounded_wireframe

ENTITY global_uncertainty_assigned_context
  SUBTYPE OF (representation_context);
  uncertainty : SET [1:?] OF uncertainty_measure_with_unit;
END_ENTITY; -- 10303-43: representation_schema

ENTITY global_unit_assigned_context
  SUBTYPE OF (representation_context);
  units : SET [1:?] OF unit;
END_ENTITY; -- 10303-41: measure_schema

ENTITY grooving_turning_operation
  SUBTYPE OF (turning_type_operation);
  WHERE
  WR1: (SELF.description IN ['roughing', 'finishing', 'cutting in']);

  WR2: (verify_optional_action_property (SELF, 'dwell')) AND
  (verify_rep_type_for_action_property (SELF, 'dwell',

```



```

    ['INTEGRATED_CNC_SCHEMA.MACHINING_DWELL_TIME_REPRESENTATION']));

WR3: (verify_optional_action_property      (SELF, 'allowance')) AND
      (verify_length_measure_action_property (SELF, 'allowance'));

-- allowance property required for roughing
WR4: NOT (SELF.description = 'roughing') OR
      (verify_required_action_property (SELF, 'allowance'));

-- allowance property forbidden for cutting in
WR5: NOT (SELF.description = 'cutting in') OR
      (0 = SIZEOF (get_action_property (SELF, 'allowance')));
END_ENTITY; -- 10303-238: integrated_cnc_schema

ENTITY group;
  name      : label;
  description : OPTIONAL text;
  DERIVE
  id : identifier := get_id_value(SELF);
  WHERE
  WR1: SIZEOF(USEDIN(SELF, 'INTEGRATED_CNC_SCHEMA.' +
                    'ID_ATTRIBUTE.IDENTIFIED_ITEM')) <= 1;
END_ENTITY; -- 10303-41: group_schema

ENTITY hole_bottom
  SUBTYPE OF (shape_aspect);
  WHERE
  WR1: 'INTEGRATED_CNC_SCHEMA.FEATURE_COMPONENT_DEFINITION' IN TYPEOF(
        SELF.of_shape.definition);
  WR2: SELF.description IN [ 'through', 'flat', 'flat with radius',
                             'flat with taper', 'spherical', 'conical' ];
  WR3: NOT (SELF.description = 'through') OR (SIZEOF(QUERY (pd <* USEDIN(
        SELF, 'INTEGRATED_CNC_SCHEMA.PROPERTY_DEFINITION.DEFINITION')
        | NOT (SIZEOF(USEDIN(pd, 'INTEGRATED_CNC_SCHEMA.' +
                             'PROPERTY_DEFINITION_REPRESENTATION.DEFINITION')) = 0))) = 0)
        ;
  WR4: NOT (SELF.description IN [ 'flat with radius', 'flat with taper',
                                   'spherical', 'conical' ]) OR (SIZEOF(QUERY (pd <* USEDIN(SELF
        , 'INTEGRATED_CNC_SCHEMA.PROPERTY_DEFINITION.DEFINITION') |
        NOT (SIZEOF(QUERY (pdr <* USEDIN(pd, 'INTEGRATED_CNC_SCHEMA.'
        + 'PROPERTY_DEFINITION_REPRESENTATION.DEFINITION') | (
        'INTEGRATED_CNC_SCHEMA.' +
        'SHAPE_REPRESENTATION_WITH_PARAMETERS' IN TYPEOF(pdr.
        used_representation)))) = 1))) = 0);
  WR5: NOT (SELF.description = 'flat') OR (SIZEOF(QUERY (pd <* USEDIN(
        SELF, 'INTEGRATED_CNC_SCHEMA.PROPERTY_DEFINITION.DEFINITION')
        | NOT (SIZEOF(QUERY (impl_rep <* QUERY (pdr <* USEDIN(pd,
        'INTEGRATED_CNC_SCHEMA.' +
        'PROPERTY_DEFINITION_REPRESENTATION.DEFINITION') | (
        'INTEGRATED_CNC_SCHEMA.' +
        'SHAPE_REPRESENTATION_WITH_PARAMETERS' IN TYPEOF(pdr.
        used_representation)))) | NOT (SIZEOF(impl_rep.
        used_representation.items) = 0))) = 0))) = 0);
  WR6: NOT (SELF.description IN [ 'flat with radius', 'spherical' ]) OR (

```

```

        SIZEOF(QUERY (pd <* USEDIN(SELF,
        'INTEGRATED_CNC_SCHEMA.PROPERTY_DEFINITION.DEFINITION')| NOT
        (SIZEOF(QUERY (impl_rep <* QUERY (pdr <* USEDIN(pd,
        'INTEGRATED_CNC_SCHEMA.' +
        'PROPERTY_DEFINITION_REPRESENTATION.DEFINITION')| (
        'INTEGRATED_CNC_SCHEMA.' +
        'SHAPE_REPRESENTATION_WITH_PARAMETERS' IN TYPEOF(pdr.
        used_representation)))| NOT (SIZEOF(impl_rep.
        used_representation.items) = 1))) = 0))) = 0);
WR7: NOT (SELF.description = 'flat with taper') OR (SIZEOF(QUERY (pd <*
        USEDIN(SELF,
        'INTEGRATED_CNC_SCHEMA.PROPERTY_DEFINITION.DEFINITION')| NOT
        (SIZEOF(QUERY (impl_rep <* QUERY (pdr <* USEDIN(pd,
        'INTEGRATED_CNC_SCHEMA.' +
        'PROPERTY_DEFINITION_REPRESENTATION.DEFINITION')| (
        'INTEGRATED_CNC_SCHEMA.' +
        'SHAPE_REPRESENTATION_WITH_PARAMETERS' IN TYPEOF(pdr.
        used_representation)))| NOT (SIZEOF(impl_rep.
        used_representation.items) = 2))) = 0))) = 0);
WR8: NOT (SELF.description = 'conical') OR (SIZEOF(QUERY (pd <* USEDIN(
        SELF, 'INTEGRATED_CNC_SCHEMA.PROPERTY_DEFINITION.DEFINITION')
        | NOT (SIZEOF(QUERY (impl_rep <* QUERY (pdr <* USEDIN(pd,
        'INTEGRATED_CNC_SCHEMA.' +
        'PROPERTY_DEFINITION_REPRESENTATION.DEFINITION')| (
        'INTEGRATED_CNC_SCHEMA.' +
        'SHAPE_REPRESENTATION_WITH_PARAMETERS' IN TYPEOF(pdr.
        used_representation)))| NOT (SIZEOF(impl_rep.
        used_representation.items) >= 1) AND (SIZEOF(impl_rep.
        used_representation.items) <= 2))) = 0))) = 0);
WR9: (SELF.description = 'through') OR (SIZEOF(QUERY (fcr <* QUERY (sar
        <* USEDIN(SELF,
        'INTEGRATED_CNC_SCHEMA.SHAPE_ASPECT_RELATIONSHIP.' +
        'RELATING_SHAPE_ASPECT')| (sar.description =
        'hole bottom usage') AND (
        'INTEGRATED_CNC_SCHEMA.FEATURE_COMPONENT_RELATIONSHIP' IN
        TYPEOF(sar)))| (fcr.name IN [ 'hole depth start',
        'hole depth end' ]))) >= 1);
WR10: NOT (SELF.description = 'flat with radius') OR (SIZEOF(QUERY (pd
        <* USEDIN(SELF,
        'INTEGRATED_CNC_SCHEMA.PROPERTY_DEFINITION.DEFINITION')| NOT
        (SIZEOF(QUERY (impl_rep <* QUERY (pdr <* USEDIN(pd,
        'INTEGRATED_CNC_SCHEMA.' +
        'PROPERTY_DEFINITION_REPRESENTATION.DEFINITION')| (
        'INTEGRATED_CNC_SCHEMA.' +
        'SHAPE_REPRESENTATION_WITH_PARAMETERS' IN TYPEOF(pdr.
        used_representation)))| NOT (SIZEOF(QUERY (it <* impl_rep.
        used_representation.items| (SIZEOF([
        'INTEGRATED_CNC_SCHEMA.MEASURE_REPRESENTATION_ITEM',
        'INTEGRATED_CNC_SCHEMA.LENGTH_MEASURE_WITH_UNIT' ] * TYPEOF(
        it)) = 2) AND (it.name = 'corner radius')) = 1))) = 0))) = 0
        );
WR11: NOT (SELF.description = 'spherical') OR (SIZEOF(QUERY (pd <*
        USEDIN(SELF,
        'INTEGRATED_CNC_SCHEMA.PROPERTY_DEFINITION.DEFINITION')| NOT

```

```

(SIZEOF(QUERY (impl_rep <* QUERY (pdr <* USEDIN(pd,
'INTEGRATED_CNC_SCHEMA.' +
'PROPERTY_DEFINITION_REPRESENTATION.DEFINITION')| (
'INTEGRATED_CNC_SCHEMA.' +
'SHAPE_REPRESENTATION_WITH_PARAMETERS' IN TYPEOF(pdr.
used_representation)))| NOT (SIZEOF(QUERY (it <* impl_rep.
used_representation.items| (SIZEOF([
'INTEGRATED_CNC_SCHEMA.MEASURE_REPRESENTATION_ITEM',
'INTEGRATED_CNC_SCHEMA.LENGTH_MEASURE_WITH_UNIT' ] * TYPEOF(
it)) = 2) AND (it.name = 'radius')) = 1))) = 0))) = 0);
WR12: NOT (SELF.description = 'conical') OR (SIZEOF(QUERY (pd <* USEDIN
(SELF, 'INTEGRATED_CNC_SCHEMA.PROPERTY_DEFINITION.DEFINITION'
)| NOT (SIZEOF(QUERY (impl_rep <* QUERY (pdr <* USEDIN(pd,
'INTEGRATED_CNC_SCHEMA.' +
'PROPERTY_DEFINITION_REPRESENTATION.DEFINITION')| (
'INTEGRATED_CNC_SCHEMA.' +
'SHAPE_REPRESENTATION_WITH_PARAMETERS' IN TYPEOF(pdr.
used_representation)))| NOT (SIZEOF(QUERY (it <* impl_rep.
used_representation.items| (SIZEOF([
'INTEGRATED_CNC_SCHEMA.MEASURE_REPRESENTATION_ITEM',
'INTEGRATED_CNC_SCHEMA.LENGTH_MEASURE_WITH_UNIT' ] * TYPEOF(
it)) = 2) AND (it.name = 'tip radius')) <= 1))) = 0))) = 0);
WR13: NOT (SELF.description = 'conical') OR (SIZEOF(QUERY (pd <* USEDIN
(SELF, 'INTEGRATED_CNC_SCHEMA.PROPERTY_DEFINITION.DEFINITION'
)| NOT (SIZEOF(QUERY (impl_rep <* QUERY (pdr <* USEDIN(pd,
'INTEGRATED_CNC_SCHEMA.' +
'PROPERTY_DEFINITION_REPRESENTATION.DEFINITION')| (
'INTEGRATED_CNC_SCHEMA.' +
'SHAPE_REPRESENTATION_WITH_PARAMETERS' IN TYPEOF(pdr.
used_representation)))| NOT (SIZEOF(QUERY (it <* impl_rep.
used_representation.items| (SIZEOF([
'INTEGRATED_CNC_SCHEMA.MEASURE_REPRESENTATION_ITEM',
'INTEGRATED_CNC_SCHEMA.PLANE_ANGLE_MEASURE_WITH_UNIT' ] *
TYPEOF(it)) = 2) AND (it.name = 'tip angle')) = 1))) = 0)))
= 0);
WR14: SIZEOF(QUERY (fcr <* QUERY (sar <* USEDIN(SELF,
'INTEGRATED_CNC_SCHEMA.SHAPE_ASPECT_RELATIONSHIP.' +
'RELATING_SHAPE_ASPECT')| (sar.description =
'hole bottom usage') AND (
'INTEGRATED_CNC_SCHEMA.FEATURE_COMPONENT_RELATIONSHIP' IN
TYPEOF(sar)))| ((fcr.related_shape_aspect.description =
'bottom condition occurrence') AND (
'INTEGRATED_CNC_SCHEMA.ROUND_HOLE' IN TYPEOF(fcr.
related_shape_aspect.of_shape.definition))) AND (
'INTEGRATED_CNC_SCHEMA.HOLE_BOTTOM' IN TYPEOF(fcr.
relating_shape_aspect)))) >= 1;
WR15: NOT (SELF.description = 'flat with taper') OR (SIZEOF(QUERY (pd
<* USEDIN(SELF,
'INTEGRATED_CNC_SCHEMA.PROPERTY_DEFINITION.DEFINITION')| NOT
(SIZEOF(QUERY (impl_rep <* QUERY (pdr <* USEDIN(pd,
'INTEGRATED_CNC_SCHEMA.' +
'PROPERTY_DEFINITION_REPRESENTATION.DEFINITION')| (
'INTEGRATED_CNC_SCHEMA.' +
'SHAPE_REPRESENTATION_WITH_PARAMETERS' IN TYPEOF(pdr.

```

```

        used_representation)))| NOT (SIZEOF(QUERY (it <* impl_rep.
        used_representation.items| (SIZEOF([
        'INTEGRATED_CNC_SCHEMA.MEASURE_REPRESENTATION_ITEM',
        'INTEGRATED_CNC_SCHEMA.LENGTH_MEASURE_WITH_UNIT' ] * TYPEOF(
        it)) = 2) AND (it.name = 'final diameter')) = 1))) = 0))) =
        0);
    WR16: NOT (SELF.description = 'flat with taper') OR (SIZEOF(QUERY (pd
    <* USEDIN(SELF,
    'INTEGRATED_CNC_SCHEMA.PROPERTY_DEFINITION.DEFINITION')| NOT
    (SIZEOF(QUERY (impl_rep <* QUERY (pdr <* USEDIN(pd,
    'INTEGRATED_CNC_SCHEMA.' +
    'PROPERTY_DEFINITION_REPRESENTATION.DEFINITION')| (
    'INTEGRATED_CNC_SCHEMA.' +
    'SHAPE_REPRESENTATION_WITH_PARAMETERS' IN TYPEOF(pdr.
    used_representation)))| NOT (SIZEOF(QUERY (it <* impl_rep.
    used_representation.items| (SIZEOF([
    'INTEGRATED_CNC_SCHEMA.MEASURE_REPRESENTATION_ITEM',
    'INTEGRATED_CNC_SCHEMA.PLANE_ANGLE_MEASURE_WITH_UNIT' ] *
    TYPEOF(it)) = 2) AND (it.name = 'taper diameter')) = 1))) =
    0))) = 0);
END_ENTITY; -- 10303-522: aic_machining_feature

ENTITY hyperbola
    SUBTYPE OF (conic);
    semi_axis      : positive_length_measure;
    semi_imag_axis : positive_length_measure;
END_ENTITY; -- 10303-42: geometry_schema

ENTITY id_attribute;
    attribute_value : identifier;
    identified_item : id_attribute_select;
END_ENTITY; -- 10303-41: basic_attribute_schema

ENTITY identification_assignment
    ABSTRACT SUPERTYPE;
    assigned_id : identifier;
    role        : identification_role;
END_ENTITY; -- 10303-41: management_resources_schema

ENTITY identification_role;
    name      : label;
    description : OPTIONAL text;
END_ENTITY; -- 10303-41: management_resources_schema

ENTITY instanced_feature
    SUBTYPE OF (feature_definition, shape_aspect);
    WHERE
        WR1: 'INTEGRATED_CNC_SCHEMA.PRODUCT_DEFINITION' IN TYPEOF(SELF.of_shape
            .definition);
        WR2: SELF.product_definitional;
END_ENTITY; -- 10303-522: aic_machining_feature

ENTITY int_literal
    SUBTYPE OF (literal_number);

```

```

        SELF\literal_number.the_value : INTEGER;
END_ENTITY; -- 13584-20: iso13584_expressions_schema

ENTITY int_numeric_variable
  SUBTYPE OF (numeric_variable);
END_ENTITY; -- 13584-20: iso13584_expressions_schema

ENTITY intersection_curve
  SUBTYPE OF (surface_curve);
  WHERE
    WR1: SIZEOF(SELF\surface_curve.associated_geometry) = 2;
    WR2: associated_surface(SELF\surface_curve.associated_geometry[1]) <>
          associated_surface(SELF\surface_curve.associated_geometry[2])
        ;
END_ENTITY; -- 10303-42: geometry_schema

ENTITY item_defined_transformation;
  name          : label;
  description    : OPTIONAL text;
  transform_item_1 : representation_item;
  transform_item_2 : representation_item;
END_ENTITY; -- 10303-43: representation_schema

ENTITY known_source
  SUBTYPE OF (external_source, pre_defined_item);
END_ENTITY; -- 10303-238: integrated_cnc_schema

ENTITY knurling_turning_operation
  SUBTYPE OF (turning_type_operation);
END_ENTITY; -- 10303-238: integrated_cnc_schema

ENTITY length_measure_with_unit
  SUBTYPE OF (measure_with_unit);
  WHERE
    WR1: 'INTEGRATED_CNC_SCHEMA.LENGTH_UNIT' IN TYPEOF(SELF\
              measure_with_unit.unit_component);
END_ENTITY; -- 10303-41: measure_schema

ENTITY length_unit
  SUBTYPE OF (named_unit);
  WHERE
    WR1: ((((((SELF\named_unit.dimensions.length_exponent = 1.0) AND (SELF\
              named_unit.dimensions.mass_exponent = 0.0)) AND (SELF\
              named_unit.dimensions.time_exponent = 0.0)) AND (SELF\
              named_unit.dimensions.electric_current_exponent = 0.0)) AND (
              SELF\named_unit.dimensions.thermodynamic_temperature_exponent
              = 0.0)) AND (SELF\named_unit.dimensions.
              amount_of_substance_exponent = 0.0)) AND (SELF\named_unit.
              dimensions.luminous_intensity_exponent = 0.0);
END_ENTITY; -- 10303-41: measure_schema

ENTITY limits_and_fits;
  form_variance : label;
  zone_variance : label;

```

ISO 10303-238:2007(E)

```

    grade      : label;
    source     : text;
END_ENTITY; -- 10303-47: shape_tolerance_schema

ENTITY line
  SUBTYPE OF (curve);
  pnt : cartesian_point;
  dir : vector;
  WHERE
    WR1: dir.dim = pnt.dim;
END_ENTITY; -- 10303-42: geometry_schema

ENTITY line_profile_tolerance
  SUBTYPE OF (geometric_tolerance);
  WHERE
    WR1: NOT ('INTEGRATED_CNC_SCHEMA.' +
              'GEOMETRIC_TOLERANCE_WITH_DATUM_REFERENCE' IN TYPEOF(SELF))
        OR (SIZEOF(SELF\geometric_tolerance_with_datum_reference.
                  datum_system) <= 3);
    WR2: SIZEOF(QUERY (sar <* USEDIN(SELF\geometric_tolerance.
                  toleranced_shape_aspect, 'INTEGRATED_CNC_SCHEMA.' +
                  'SHAPE_ASPECT_RELATIONSHIP.RELATING_SHAPE_ASPECT')| (sar.name
                  IN [ 'affected plane association',
                  'resulting intersection curve association' ]))) = 1;
END_ENTITY; -- 10303-519: aic_geometric_tolerances

ENTITY linear_profile
  SUBTYPE OF (shape_aspect);
  WHERE
    WR1: 'INTEGRATED_CNC_SCHEMA.FEATURE_COMPONENT_DEFINITION' IN TYPEOF(
          SELF.of_shape.definition);
    WR2: SIZEOF(QUERY (pd <* USEDIN(SELF,
          'INTEGRATED_CNC_SCHEMA.PROPERTY_DEFINITION.DEFINITION')| NOT
          (SIZEOF(QUERY (pdr <* USEDIN(pd, 'INTEGRATED_CNC_SCHEMA.' +
          'PROPERTY_DEFINITION_REPRESENTATION.DEFINITION')| (
          'INTEGRATED_CNC_SCHEMA.' +
          'SHAPE_REPRESENTATION_WITH_PARAMETERS' IN TYPEOF(pdr.
          used_representation)))) = 1))) = 0;
    WR3: SIZEOF(QUERY (pd <* USEDIN(SELF,
          'INTEGRATED_CNC_SCHEMA.PROPERTY_DEFINITION.DEFINITION')| NOT
          (SIZEOF(QUERY (impl_rep <* QUERY (pdr <* USEDIN(pd,
          'INTEGRATED_CNC_SCHEMA.' +
          'PROPERTY_DEFINITION_REPRESENTATION.DEFINITION')| (
          'INTEGRATED_CNC_SCHEMA.' +
          'SHAPE_REPRESENTATION_WITH_PARAMETERS' IN TYPEOF(pdr.
          used_representation)))| NOT (SIZEOF(impl_rep.
          used_representation.items) = 2))) = 0))) = 0;
    WR4: SIZEOF(QUERY (pd <* USEDIN(SELF,
          'INTEGRATED_CNC_SCHEMA.PROPERTY_DEFINITION.DEFINITION')| NOT
          (SIZEOF(QUERY (impl_rep <* QUERY (pdr <* USEDIN(pd,
          'INTEGRATED_CNC_SCHEMA.' +
          'PROPERTY_DEFINITION_REPRESENTATION.DEFINITION')| (
          'INTEGRATED_CNC_SCHEMA.' +
          'SHAPE_REPRESENTATION_WITH_PARAMETERS' IN TYPEOF(pdr.

```

```

used_representation)))| NOT (SIZEOF(QUERY (it <* impl_rep.
used_representation.items| ('INTEGRATED_CNC_SCHEMA.PLACEMENT'
  IN TYPEOF(it)) AND (it.name = 'orientation')))) = 1))) = 0)))
= 0;
WR5: SIZEOF(QUERY (pd <* USEDIN(SELF,
  'INTEGRATED_CNC_SCHEMA.PROPERTY_DEFINITION.DEFINITION')| NOT
(SIZEOF(QUERY (impl_rep <* QUERY (pdr <* USEDIN(pd,
  'INTEGRATED_CNC_SCHEMA.' +
  'PROPERTY_DEFINITION_REPRESENTATION.DEFINITION')| (
  'INTEGRATED_CNC_SCHEMA.' +
  'SHAPE_REPRESENTATION_WITH_PARAMETERS' IN TYPEOF(pdr.
used_representation)))| NOT (SIZEOF(QUERY (it <* impl_rep.
used_representation.items| (SIZEOF([
  'INTEGRATED_CNC_SCHEMA.MEASURE_REPRESENTATION_ITEM',
  'INTEGRATED_CNC_SCHEMA.LENGTH_MEASURE_WITH_UNIT' ] * TYPEOF(
it)) = 2) AND (it.name = 'profile length')))) = 1))) = 0))) =
0;
END_ENTITY; -- 10303-522: aic_machining_feature

ENTITY literal_number
  ABSTRACT SUPERTYPE OF (ONEOF(int_literal, real_literal))
  SUBTYPE OF (simple_numeric_expression, generic_literal);
  the_value : NUMBER;
END_ENTITY; -- 13584-20: iso13584_expressions_schema

ENTITY local_time;
  hour_component : hour_in_day;
  minute_component : OPTIONAL minute_in_hour;
  second_component : OPTIONAL second_in_minute;
  zone : coordinated_universal_time_offset;
  WHERE
    WR1: valid_time(SELF);
END_ENTITY; -- 10303-41: date_time_schema

ENTITY location_shape_representation
  SUBTYPE OF (shape_representation);
  WHERE
    WR1: SIZEOF(SELF.items) = 1;
    WR2: SIZEOF(QUERY (it <* SELF.items| NOT ('INTEGRATED_CNC_SCHEMA.POINT'
      IN TYPEOF(it)))) = 0;
END_ENTITY; -- 10303-522: aic_machining_feature

ENTITY loop
  SUPERTYPE OF (ONEOF(vertex_loop, edge_loop, poly_loop))
  SUBTYPE OF (topological_representation_item);
END_ENTITY; -- 10303-42: topology_schema

ENTITY machining_adaptive_control_relationship
  SUBTYPE OF (action_method_relationship);
END_ENTITY; -- 10303-238: integrated_cnc_schema

ENTITY machining_approach_retract_strategy
  SUBTYPE OF (machining_strategy);
  WHERE

```

ISO 10303-238:2007(E)

```

WR1: (SELF.description IN ['along path',
    'approach retract angle', 'approach retract tangent',
    'plunge helix', 'plunge ramp', 'plunge toolaxis',
    'plunge zigzag']);

WR2: (verify_optional_action_property      (SELF, 'tool orientation')) AND
(verify_rep_item_for_action_property      (SELF, 'tool orientation',
    ['INTEGRATED_CNC_SCHEMA.DIRECTION']));

WR3: NOT (SELF.description = 'along path') OR
((1 <= get_count_of_relating_amr (SELF,
    ['INTEGRATED_CNC_SCHEMA.MACHINING_TOOLPATH_SEQUENCE_RELATIONSHIP']))
AND
    (verify_related_type_for_amr      (SELF,
    ['INTEGRATED_CNC_SCHEMA.MACHINING_TOOLPATH_SEQUENCE_RELATIONSHIP'],
    ['INTEGRATED_CNC_SCHEMA.MACHINING_TOOLPATH']))
);

WR4: NOT (SELF.description = 'approach retract angle') OR
((verify_required_action_property      (SELF, 'travel angle')) AND
(verify_angle_measure_action_property  (SELF, 'travel angle')) AND

    (verify_required_action_property      (SELF, 'travel length')) AND
(verify_length_measure_action_property (SELF, 'travel length')));

WR5: NOT (SELF.description = 'approach retract tangent') OR
((verify_required_action_property      (SELF, 'travel radius')) AND
(verify_length_measure_action_property (SELF, 'travel radius')));

WR6: NOT (SELF.description IN ['plunge helix', 'plunge ramp', 'plunge
zigzag']) OR
((verify_required_action_property      (SELF, 'plunge angle')) AND
(verify_angle_measure_action_property  (SELF, 'plunge angle')));

WR7: NOT (SELF.description = 'plunge helix') OR
((verify_required_action_property      (SELF, 'plunge radius')) AND
(verify_length_measure_action_property (SELF, 'plunge radius')));

WR8: NOT (SELF.description = 'plunge zigzag') OR
((verify_required_action_property      (SELF, 'plunge width')) AND
(verify_length_measure_action_property (SELF, 'plunge width')));
END_ENTITY; -- 10303-238: integrated_cnc_schema

ENTITY machining_cutting_component
    SUBTYPE OF (action_resource,characterized_object);
    WHERE
    WR1: (1 >= SIZEOF (USEDIN (SELF, 'INTEGRATED_CNC_SCHEMA.' +
        'MATERIAL_DESIGNATION.DEFINITIONS')));

    WR2: (1 >= SIZEOF (QUERY (arr <* USEDIN (SELF,
        'INTEGRATED_CNC_SCHEMA.REQUIREMENT_FOR_ACTION_RESOURCE.RESOURCES') |
        (arr.kind.name = 'cutting component') AND
        (0 < SIZEOF (QUERY (mt <* arr.operations |
            'INTEGRATED_CNC_SCHEMA.MACHINING_TECHNOLOGY' IN TYPEOF (mt))))

```



```

));

WR3: (verify_optional_resource_property (SELF, 'expected life')) AND
      (verify_time_measure_resource_property (SELF, 'expected life'));

WR4: NOT (SELF.kind.name = 'milling cutting edge') OR
      ((verify_required_resource_property
        (SELF, 'functional length')) AND
       (verify_length_measure_resource_property
        (SELF, 'functional length'))
      );

WR5: NOT (SELF.kind.name = 'turning cutting edge') OR
      ((verify_optional_resource_property
        (SELF, 'cutting edge length')) AND
       (verify_length_measure_resource_property
        (SELF, 'cutting edge length')) AND

      (verify_optional_resource_property
        (SELF, 'cutting edge angle')) AND
       (verify_angle_measure_resource_property
        (SELF, 'cutting edge angle')) AND

      (verify_optional_resource_property
        (SELF, 'cutting edge angle type')) AND
       (verify_rep_item_for_resource_property
        (SELF, 'cutting edge angle type',
         ['INTEGRATED_CNC_SCHEMA.DESRIPTIVE_REPRESENTATION_ITEM'])) AND

      (verify_optional_resource_property
        (SELF, 'tool included angle')) AND
       (verify_angle_measure_resource_property
        (SELF, 'tool included angle')) AND

      (verify_rep_type_for_resource_property
        (SELF, 'corner transitions',
         ['INTEGRATED_CNC_SCHEMA.'+
          'MACHINING_CUTTING_CORNER_REPRESENTATION'])) AND

      (verify_optional_resource_property
        (SELF, 'maximum side cutting depth')) AND
       (verify_length_measure_resource_property
        (SELF, 'maximum side cutting depth')) AND

      (verify_optional_resource_property
        (SELF, 'maximum end cutting depth')) AND
       (verify_length_measure_resource_property
        (SELF, 'maximum end cutting depth'))
      );
END_ENTITY; -- 10303-238: integrated_cnc_schema

ENTITY machining_cutting_corner_representation
  SUBTYPE OF (representation);

```

```

WHERE
WR1: ((verify_required_rep_item      (SELF, 'corner identity')) AND
      (verify_count_measure_rep_item (SELF, 'corner identity'))
      );

WR2: NOT (SELF.name = 'chamfered corner') OR
      ((verify_required_rep_item      (SELF, 'chamfer angle')) AND
      (verify_angle_measure_rep_item  (SELF, 'chamfer angle')) AND

      (verify_optional_rep_item       (SELF, 'chamfer length')) AND
      (verify_length_measure_rep_item (SELF, 'chamfer length')) AND

      (verify_optional_rep_item       (SELF, 'chamfer width')) AND
      (verify_length_measure_rep_item (SELF, 'chamfer width'))
      );

WR3: NOT (SELF.name = 'rounded corner') OR
      ((verify_required_rep_item      (SELF, 'radius')) AND
      (verify_length_measure_rep_item (SELF, 'radius'))
      );

WR4: NOT (SELF.name = 'profiled corner') OR
      (1 = SIZEOF (QUERY (prep <* USEDIN (SELF, 'INTEGRATED_CNC_SCHEMA.' +
      'PROPERTY_DEFINITION_REPRESENTATION.USED_REPRESENTATION') |
      (('INTEGRATED_CNC_SCHEMA.LINEAR_PROFILE'
      IN TYPEOF(prepare.definition)) OR
      ('INTEGRATED_CNC_SCHEMA.OPEN_PATH_PROFILE'
      IN TYPEOF(prepare.definition)) OR
      ('INTEGRATED_CNC_SCHEMA.PARTIAL_CIRCULAR_PROFILE'
      IN TYPEOF(prepare.definition)) OR
      ('INTEGRATED_CNC_SCHEMA.ROUNDED_U_PROFILE'
      IN TYPEOF(prepare.definition)) OR
      ('INTEGRATED_CNC_SCHEMA.SQUARE_U_PROFILE'
      IN TYPEOF(prepare.definition)) OR
      ('INTEGRATED_CNC_SCHEMA.TEE_PROFILE'
      IN TYPEOF(prepare.definition)) OR
      ('INTEGRATED_CNC_SCHEMA.VEE_PROFILE'
      IN TYPEOF(prepare.definition)))
      )));
END_ENTITY; -- 10303-238: integrated_cnc_schema

ENTITY machining_dwell_time_representation
  SUBTYPE OF (representation);
  WHERE
  WR1: (SELF.name IN ['dwell time', 'dwell revolution']);

  WR2: NOT (SELF.name = 'dwell time') OR
        ((verify_required_rep_item      (SELF, 'dwell time')) AND
        (verify_time_measure_rep_item  (SELF, 'dwell time'))
        );

  WR3: NOT (SELF.name = 'dwell revolution') OR
        ((verify_required_rep_item      (SELF, 'dwell revolution')) AND
        (verify_count_measure_rep_item  (SELF, 'dwell revolution'))
        );

```

```

    );
END_ENTITY; -- 10303-238: integrated_cnc_schema

ENTITY machining_execution_resource
  SUBTYPE OF (action_resource);
  WHERE
  WR1: ((verify_optional_resource_property      (SELF, 'feedrate')) AND
        (verify_rep_type_for_resource_property (SELF, 'feedrate',
          ['INTEGRATED_CNC_SCHEMA.MACHINING_FEED_SPEED_REPRESENTATION'])));

  WR2: ((verify_optional_resource_property      (SELF, 'spindle')) AND
        (verify_rep_type_for_resource_property (SELF, 'spindle',
          ['INTEGRATED_CNC_SCHEMA.MACHINING_SPINDLE_SPEED_REPRESENTATION'])));

  WR3: ((verify_optional_resource_property      (SELF, 'spindle power')) AND
        (verify_rep_item_for_resource_property (SELF, 'spindle power',
          ['INTEGRATED_CNC_SCHEMA.MEASURE_REPRESENTATION_ITEM'])));

  WR4: ((verify_optional_resource_property      (SELF, 'spindle torque')) AND
        (verify_rep_item_for_resource_property (SELF, 'spindle torque',
          ['INTEGRATED_CNC_SCHEMA.MEASURE_REPRESENTATION_ITEM'])));

  WR5: ((verify_optional_resource_property
        (SELF, 'number of control axis')) AND
        (verify_count_measure_resource_property
        (SELF, 'number of control axis')));

  WR6: ((verify_optional_resource_property
        (SELF, 'number of simultaneous axis')) AND
        (verify_count_measure_resource_property
        (SELF, 'number of simultaneous axis')));

  WR7: ((verify_optional_resource_property
        (SELF, 'positioning accuracy')) AND
        (verify_length_measure_resource_property
        (SELF, 'positioning accuracy')));

  WR8: ((verify_optional_resource_property      (SELF, 'table indexing')) AND
        (verify_enumeration_resource_property (SELF, 'table indexing',
          ['required', 'not required'])));

  WR9: ((verify_optional_resource_property
        (SELF, 'table length')) AND
        (verify_length_measure_resource_property
        (SELF, 'table length')) AND

        (verify_optional_resource_property
        (SELF, 'table width')) AND
        (verify_length_measure_resource_property
        (SELF, 'table width')));

  WR10: ((verify_optional_resource_property      (SELF, 'axis travel')) AND
        (0 = SIZEOF (QUERY (prop <* get_resource_property
          (SELF, 'axis travel') | NOT

```

```

        ((0 < SIZEOF (QUERY (prep <* USEDIN (prop,
        'INTEGRATED_CNC_SCHEMA.RESOURCE_PROPERTY_REPRESENTATION.PROPERTY') |
        (1 <= SIZEOF (QUERY ( it <* prep.representation.items |
        (SIZEOF([
        'INTEGRATED_CNC_SCHEMA.MEASURE_REPRESENTATION_ITEM',
        'INTEGRATED_CNC_SCHEMA.LENGTH_MEASURE_WITH_UNIT'] *
        TYPEOF(it)) = 2))))
        )))
    )));

WR11: ((verify_optional_resource_property
        (SELF, 'work volume length')) AND
        (verify_length_measure_resource_property
        (SELF, 'work volume length')) AND

        (verify_optional_resource_property
        (SELF, 'work volume width')) AND
        (verify_length_measure_resource_property
        (SELF, 'work volume width')) AND

        (verify_optional_resource_property
        (SELF, 'work volume height')) AND
        (verify_length_measure_resource_property
        (SELF, 'work volume height'))
    );

WR12: (0 = SIZEOF (get_action_property (SELF, 'axis travel')) OR
        ((0 = SIZEOF (get_action_property (SELF, 'work volume length')) AND
        (0 = SIZEOF (get_action_property (SELF, 'work volume width')) AND
        (0 = SIZEOF (get_action_property (SELF, 'work volume height'))));

END_ENTITY; -- 10303-238: integrated_cnc_schema

ENTITY machining_feature_process
    SUBTYPE OF (machining_process_executable);
    WHERE
    WR1: (1 = SIZEOF (QUERY (act <*
        USEDIN (SELF, 'INTEGRATED_CNC_SCHEMA.ACTION.CHOSEN_METHOD') |
        (act.name = 'machining')))) AND
        (0 = SIZEOF (QUERY (act <*
        USEDIN (SELF, 'INTEGRATED_CNC_SCHEMA.ACTION.CHOSEN_METHOD') |
        (act.name = 'machining') AND NOT
        ('INTEGRATED_CNC_SCHEMA.PROPERTY_PROCESS' IN TYPEOF (act))
        )));
END_ENTITY; -- 10303-238: integrated_cnc_schema

ENTITY machining_feature_relationship
    SUBTYPE OF (action_method_relationship);
END_ENTITY; -- 10303-238: integrated_cnc_schema

ENTITY machining_feature_sequence_relationship
    SUBTYPE OF (machining_feature_relationship, sequential_method);
END_ENTITY; -- 10303-238: integrated_cnc_schema

```

```

ENTITY machining_feed_speed_representation
  SUBTYPE OF (representation);
  WHERE
  WR1: (SELF.name IN ['feed speed', 'feed per revolution',
    'feed per tooth', 'relative speed']);

  WR2: NOT (SELF.name = 'feed speed') OR
    ((verify_required_rep_item (SELF, 'feed speed')) AND
    (verify_linear_speed_measure_rep_item (SELF, 'feed speed'))
    );

  WR3: NOT (SELF.name = 'feed per revolution') OR
    ((verify_required_rep_item (SELF, 'feed per revolution')) AND
    (0 = SIZEOF (QUERY ( it <* SELF.items |
    (it.name = 'feed per revolution') AND NOT (
    'INTEGRATED_CNC_SCHEMA.MEASURE_REPRESENTATION_ITEM' IN
    TYPEOF(it)))))
    );

  WR4: NOT (SELF.name = 'feed per tooth') OR
    ((verify_required_rep_item (SELF, 'feed per tooth')) AND
    (0 = SIZEOF (QUERY ( it <* SELF.items |
    (it.name = 'feed per tooth') AND NOT (
    'INTEGRATED_CNC_SCHEMA.MEASURE_REPRESENTATION_ITEM' IN
    TYPEOF(it)))))
    );

  WR5: NOT (SELF.name = 'relative speed') OR
    ((verify_required_rep_item (SELF, 'relative speed')) AND
    (verify_ratio_measure_rep_item (SELF, 'relative speed'))
    );
END_ENTITY; -- 10303-238: integrated_cnc_schema

```

```

ENTITY machining_final_feature_relationship
  SUBTYPE OF (action_method_relationship);
END_ENTITY; -- 10303-238: integrated_cnc_schema

```

```

ENTITY machining_functions
  SUBTYPE OF (action_method);
  WHERE
  WR1: NOT (SELF.description = 'milling') OR
    ((verify_required_action_property (SELF, 'coolant')) AND
    (verify_enumeration_action_property (SELF, 'coolant',
    ['coolant on', 'coolant off'])) AND

    (verify_optional_action_property
    (SELF, 'coolant pressure')) AND
    (verify_pressure_measure_action_property
    (SELF, 'coolant pressure')) AND

    (verify_optional_action_property (SELF, 'mist')) AND
    (verify_enumeration_action_property (SELF, 'mist',
    ['mist on', 'mist off'])) AND

```

```

    (verify_optional_action_property
      (SELF, 'through spindle coolant')) AND
    (verify_enumeration_action_property
      (SELF, 'through spindle coolant',
        ['through spindle coolant on', 'through spindle coolant off'])) AND

    (verify_optional_action_property
      (SELF, 'through spindle pressure')) AND
    (verify_pressure_measure_action_property
      (SELF, 'through spindle pressure')) AND

-- axis constraints property must contain zero or more ranges
(0 = SIZEOF (QUERY (prop <* get_action_property
  (SELF, 'axis constraints') | NOT
  ((0 < SIZEOF (QUERY (prep <* USEDIN (prop,
    'INTEGRATED_CNC_SCHEMA.ACTION_PROPERTY_REPRESENTATION.PROPERTY') |
    (0 <= SIZEOF (QUERY (it <* prep.representation.items |
      ('INTEGRATED_CNC_SCHEMA.VALUE_RANGE' in TYPEOF(it))))
    ))))))))
);

WR2: NOT (SELF.description = 'turning') OR
((verify_required_action_property      (SELF, 'coolant')) AND
 (verify_enumeration_action_property   (SELF, 'coolant',
   ['coolant on', 'coolant off'])) AND

 (verify_optional_action_property      (SELF, 'coolant type')) AND
 (verify_enumeration_action_property   (SELF, 'coolant type',
   ['flood', 'mist', 'through tool'])) AND

 (verify_optional_action_property      (SELF, 'coolant pressure')) AND
 (verify_pressure_measure_action_property
   (SELF, 'coolant pressure')) AND

 (verify_optional_action_property      (SELF, 'tail stock')) AND
 (verify_enumeration_action_property   (SELF, 'tail stock',
   ['tail stock used', 'tail stock not used'])) AND

 (verify_optional_action_property      (SELF, 'steady rest')) AND
 (verify_enumeration_action_property   (SELF, 'steady rest',
   ['steady rest used', 'steady rest not used'])) AND

 (verify_optional_action_property      (SELF, 'follow rest')) AND
 (verify_enumeration_action_property   (SELF, 'follow rest',
   ['follow rest used', 'follow rest not used']))
);

WR3: NOT (SELF.description IN ['milling', 'turning']) OR
((verify_optional_action_property      (SELF, 'axis clamping')) AND
 (0 = SIZEOF (QUERY (prop <*
  get_action_property (SELF, 'axis clamping') | NOT
  (0 < SIZEOF (QUERY (prep <* USEDIN (prop, 'INTEGRATED_CNC_SCHEMA.' +

```

```

        'ACTION_PROPERTY_REPRESENTATION.PROPERTY') |
    (1 = SIZEOF (QUERY (it <* prep.representation.items |
        (('INTEGRATED_CNC_SCHEMA.COMPOUND_REPRESENTATION_ITEM'
            IN TYPEOF(it)) AND
        ('INTEGRATED_CNC_SCHEMA.LIST_REPRESENTATION_ITEM'
            IN TYPEOF(it.item_element)) AND
        (0 = SIZEOF (QUERY (ie <* it.item_element | NOT
            ('INTEGRATED_CNC_SCHEMA.DESRIPTIVE_REPRESENTATION_ITEM'
                IN TYPEOF(ie)) )))
        )))
    ))
)) AND

(verify_optional_action_property (SELF, 'chip removal')) AND
(verify_enumeration_action_property (SELF, 'chip removal',
    ['chip removal on', 'chip removal off'])) AND

(verify_optional_action_property (SELF, 'oriented spindle stop'))
AND
(verify_rep_item_for_action_property (SELF, 'oriented spindle stop',
    ['INTEGRATED_CNC_SCHEMA.DIRECTION'])) AND

(verify_related_type_for_amr (SELF,
    ['INTEGRATED_CNC_SCHEMA.MACHINING_PROCESS_MODEL_RELATIONSHIP'],
    ['INTEGRATED_CNC_SCHEMA.MACHINING_PROCESS_MODEL'])) AND

(verify_optional_action_property (SELF, 'other functions')) AND
(0 = SIZEOF (QUERY (prop <* get_action_property
    (SELF, 'other functions') | NOT
    (0 < SIZEOF (QUERY (prep <* USEDIN (prop, 'INTEGRATED_CNC_SCHEMA.' +
        'ACTION_PROPERTY_REPRESENTATION.PROPERTY') |
        (1 = SIZEOF (QUERY (it <* prep.representation.items |
            (('INTEGRATED_CNC_SCHEMA.COMPOUND_REPRESENTATION_ITEM'
                IN TYPEOF(it)) AND
            ('INTEGRATED_CNC_SCHEMA.SET_REPRESENTATION_ITEM'
                IN TYPEOF(it.item_element))))
        )))
    )))
));
END_ENTITY; -- 10303-238: integrated_cnc_schema

ENTITY machining_functions_relationship
    SUBTYPE OF (action_method_relationship);
END_ENTITY; -- 10303-238: integrated_cnc_schema

ENTITY machining_nc_function
    SUBTYPE OF (machining_process_executable);
    WHERE
    WR1: (SELF.description IN ['display message',
        'optional stop', 'program stop', 'set mark', 'wait for mark',
        'exchange pallet', 'index pallet', 'index table', 'load tool',
        'unload tool', 'legacy function']);

```

```

WR2: NOT (SELF.description = 'display message') OR
      ((verify_required_action_property      (SELF, 'message text')) AND
       (verify_descriptive_action_property  (SELF, 'message text')));

WR3: NOT (SELF.description = 'wait for mark') OR
      ((verify_required_action_property      (SELF, 'channel')));

WR4: NOT (SELF.description = 'index pallet') OR
      ((verify_required_action_property      (SELF, 'pallet index')) AND
       (verify_count_measure_action_property (SELF, 'pallet index')));

WR5: NOT (SELF.description = 'index table') OR
      ((verify_required_action_property      (SELF, 'table index')) AND
       (verify_count_measure_action_property (SELF, 'table index')));

WR6: NOT (SELF.description = 'load tool') OR
      (1 = SIZEOF (QUERY (mt <*
                        USEDIN (SELF, 'INTEGRATED_CNC_SCHEMA.ACTION_RESOURCE.USAGE') |
                        ('INTEGRATED_CNC_SCHEMA.MACHINING_TOOL' in TYPEOF(mt))));

WR7: NOT (SELF.description = 'unload tool') OR
      (1 >= SIZEOF (QUERY (mt <*
                        USEDIN (SELF, 'INTEGRATED_CNC_SCHEMA.ACTION_RESOURCE.USAGE') |
                        ('INTEGRATED_CNC_SCHEMA.MACHINING_TOOL' in TYPEOF(mt))));

WR8: NOT (SELF.description = 'legacy function') OR
      ((verify_required_action_property      (SELF, 'function text')) AND
       (verify_descriptive_action_property  (SELF, 'function text')));
END_ENTITY; -- 10303-238: integrated_cnc_schema

ENTITY machining_offset_vector_representation
  SUBTYPE OF (representation);
  WHERE
  WR1: (1 = SIZEOF (QUERY ( it <* SELF.items | (it.name = 'translate')))) AND
        (0 = SIZEOF (QUERY ( it <* SELF.items | (it.name = 'translate') AND NOT
          (('INTEGRATED_CNC_SCHEMA.COMPOUND_REPRESENTATION_ITEM'
            IN TYPEOF(it)) AND
           ('INTEGRATED_CNC_SCHEMA.LIST_REPRESENTATION_ITEM'
            IN TYPEOF(it.item_element)) AND
           (SIZEOF(it.item_element) = 3) AND
           (0 = SIZEOF (QUERY (ie <* it.item_element | NOT
             (('INTEGRATED_CNC_SCHEMA.EXPRESSION_REPRESENTATION_ITEM'
               IN TYPEOF(ie)) AND
              ('INTEGRATED_CNC_SCHEMA.NUMERIC_VARIABLE'
               IN TYPEOF(ie))))))
        )
  ));

WR2: (1 >= SIZEOF (QUERY ( it <* SELF.items | (it.name = 'rotate')))) AND
      (0 = SIZEOF (QUERY ( it <* SELF.items | (it.name = 'rotate') AND NOT
        (('INTEGRATED_CNC_SCHEMA.COMPOUND_REPRESENTATION_ITEM'
          IN TYPEOF(it)) AND
         ('INTEGRATED_CNC_SCHEMA.LIST_REPRESENTATION_ITEM'
          IN TYPEOF(it.item_element)) AND

```



```

(SIZEOF(it.item_element) = 3) AND
(0 = SIZEOF (QUERY (ie <* it.item_element | NOT
  (('INTEGRATED_CNC_SCHEMA.EXPRESSION_REPRESENTATION_ITEM'
    IN TYPEOF(ie)) AND
    ('INTEGRATED_CNC_SCHEMA.NUMERIC_VARIABLE'
    IN TYPEOF(ie))))))
)
));
END_ENTITY; -- 10303-238: integrated_cnc_schema

ENTITY machining_operation
  SUBTYPE OF (action_method);
  WHERE
  WR1: ((verify_related_type_for_amr      (SELF,
    ['INTEGRATED_CNC_SCHEMA.MACHINING_TOOLPATH_SEQUENCE_RELATIONSHIP'],
    ['INTEGRATED_CNC_SCHEMA.MACHINING_TOOLPATH']))
  );

  WR2: (verify_optional_action_property    (SELF, 'tool direction')) AND
  (verify_rep_type_for_action_property    (SELF, 'tool direction',
    ['INTEGRATED_CNC_SCHEMA.MACHINING_TOOL_DIRECTION_REPRESENTATION']));

  WR3: ('INTEGRATED_CNC_SCHEMA.MACHINING_RAPID_MOVEMENT' IN TYPEOF(SELF)) OR
  ('INTEGRATED_CNC_SCHEMA.MACHINING_TOUCH_PROBING' IN TYPEOF(SELF)) OR
  ((verify_optional_action_property      (SELF, 'retract plane')) AND
  (verify_length_measure_action_property (SELF, 'retract plane')) AND

  (verify_optional_action_property      (SELF, 'cut start point')) AND
  (verify_rep_item_for_action_property   (SELF, 'cut start point',
    ['INTEGRATED_CNC_SCHEMA.CARTESIAN_POINT'])) AND

  (1 = SIZEOF (QUERY (mt <*
    USEDIN (SELF, 'INTEGRATED_CNC_SCHEMA.ACTION_RESOURCE.USAGE') |
    ('INTEGRATED_CNC_SCHEMA.MACHINING_TOOL' in TYPEOF(mt)))))) AND

  (verify_required_relating_amr (SELF,
    ['INTEGRATED_CNC_SCHEMA.MACHINING_TECHNOLOGY_RELATIONSHIP'])) AND
  (verify_related_type_for_amr (SELF,
    ['INTEGRATED_CNC_SCHEMA.MACHINING_TECHNOLOGY_RELATIONSHIP'],
    ['INTEGRATED_CNC_SCHEMA.MACHINING_TECHNOLOGY'])) AND

  (verify_required_relating_amr (SELF,
    ['INTEGRATED_CNC_SCHEMA.MACHINING_FUNCTIONS_RELATIONSHIP'])) AND
  (verify_related_type_for_amr (SELF,
    ['INTEGRATED_CNC_SCHEMA.MACHINING_FUNCTIONS_RELATIONSHIP'],
    ['INTEGRATED_CNC_SCHEMA.MACHINING_FUNCTIONS']))
  );
END_ENTITY; -- 10303-238: integrated_cnc_schema

ENTITY machining_operation_relationship
  SUBTYPE OF (action_method_relationship);
END_ENTITY; -- 10303-238: integrated_cnc_schema

ENTITY machining_operator_instruction

```

```

SUBTYPE OF (action_method_with_associated_documents);
WHERE
WR1: EXISTS (self.description) OR (0 < SIZEOF(self.documents));
END_ENTITY; -- 10303-238: integrated_cnc_schema

ENTITY machining_operator_instruction_relationship
SUBTYPE OF (sequential_method);
END_ENTITY; -- 10303-238: integrated_cnc_schema

ENTITY machining_process_body_relationship
SUBTYPE OF (action_method_relationship);
END_ENTITY; -- 10303-238: integrated_cnc_schema

ENTITY machining_process_branch_relationship
SUBTYPE OF (machining_process_body_relationship);
END_ENTITY; -- 10303-238: integrated_cnc_schema

ENTITY machining_process_concurrent_relationship
SUBTYPE OF (machining_process_body_relationship, concurrent_action_method);
END_ENTITY; -- 10303-238: integrated_cnc_schema

ENTITY machining_process_executable
SUBTYPE OF (action_method);
WHERE
WR1: NOT (0 = SIZEOF (TYPEOF (SELF) *
    ['INTEGRATED_CNC_SCHEMA.MACHINING_FEATURE_PROCESS',
     'INTEGRATED_CNC_SCHEMA.MACHINING_NC_FUNCTION',
     'INTEGRATED_CNC_SCHEMA.MACHINING_RAPID_MOVEMENT',
     'INTEGRATED_CNC_SCHEMA.MACHINING_TOUCH_PROBING',
     'INTEGRATED_CNC_SCHEMA.MACHINING_WORKINGSTEP',
     'INTEGRATED_CNC_SCHEMA.MACHINING_WORKPLAN']
    )) OR
    (SELF.description IN ['assignment', 'if statement',
        'non-sequential', 'parallel', 'selective',
        'while statement', 'setup instructions']);

WR2: NOT (SELF.description = 'assignment') OR
    ((verify_required_action_property (SELF, 'lvalue')) AND
     (verify_rep_item_for_action_property (SELF, 'lvalue',
        ['INTEGRATED_CNC_SCHEMA.EXPRESSION_REPRESENTATION_ITEM',
         'INTEGRATED_CNC_SCHEMA.NUMERIC_VARIABLE']))) AND

    (verify_required_action_property (SELF, 'rvalue')) AND
    (verify_rep_item_for_action_property (SELF, 'rvalue',
        ['INTEGRATED_CNC_SCHEMA.EXPRESSION_REPRESENTATION_ITEM']));

WR3: NOT (SELF.description = 'if statement') OR
    ((verify_required_action_property (SELF, 'condition')) AND
     (verify_rep_item_for_action_property (SELF, 'condition',
        ['INTEGRATED_CNC_SCHEMA.EXPRESSION_REPRESENTATION_ITEM',
         'INTEGRATED_CNC_SCHEMA.BOOLEAN_EXPRESSION']))) AND

    (verify_required_relatng_amr_with_name (SELF, 'true branch',
        ['INTEGRATED_CNC_SCHEMA.MACHINING_PROCESS_BRANCH_RELATIONSHIP']))) AND

```

```

(verify_related_type_for_amr_with_name (SELF, 'true branch',
['INTEGRATED_CNC_SCHEMA.MACHINING_PROCESS_BRANCH_RELATIONSHIP'],
['INTEGRATED_CNC_SCHEMA.MACHINING_PROCESS_EXECUTABLE'])) AND

(verify_optional_relating_amr_with_name (SELF, 'false branch',
['INTEGRATED_CNC_SCHEMA.MACHINING_PROCESS_BRANCH_RELATIONSHIP'])) AND
(verify_related_type_for_amr_with_name (SELF, 'false branch',
['INTEGRATED_CNC_SCHEMA.MACHINING_PROCESS_BRANCH_RELATIONSHIP'],
['INTEGRATED_CNC_SCHEMA.MACHINING_PROCESS_EXECUTABLE']))
);

WR4: NOT (SELF.description = 'while statement') OR
((verify_required_action_property (SELF, 'condition')) AND
(verify_rep_item_for_action_property (SELF, 'condition',
['INTEGRATED_CNC_SCHEMA.EXPRESSION_REPRESENTATION_ITEM',
'INTEGRATED_CNC_SCHEMA.BOOLEAN_EXPRESSION'])) AND

(verify_required_relating_amr (SELF,
['INTEGRATED_CNC_SCHEMA.MACHINING_PROCESS_BODY_RELATIONSHIP'])) AND
(verify_related_type_for_amr (SELF,
['INTEGRATED_CNC_SCHEMA.MACHINING_PROCESS_BODY_RELATIONSHIP'],
['INTEGRATED_CNC_SCHEMA.MACHINING_PROCESS_EXECUTABLE']))
);

WR5: NOT (SELF.description = 'parallel') OR
((2 <= get_count_of_relating_amr (SELF,
['INTEGRATED_CNC_SCHEMA.MACHINING_PROCESS_CONCURRENT_RELATIONSHIP']))
AND
(verify_related_type_for_amr (SELF,
['INTEGRATED_CNC_SCHEMA.MACHINING_PROCESS_CONCURRENT_RELATIONSHIP'],
['INTEGRATED_CNC_SCHEMA.MACHINING_PROCESS_EXECUTABLE']))
);

WR6: NOT (SELF.description = 'non-sequential') OR
((2 <= get_count_of_relating_amr (SELF,
['INTEGRATED_CNC_SCHEMA.MACHINING_PROCESS_BODY_RELATIONSHIP'])) AND
(verify_related_type_for_amr (SELF,
['INTEGRATED_CNC_SCHEMA.MACHINING_PROCESS_BODY_RELATIONSHIP'],
['INTEGRATED_CNC_SCHEMA.MACHINING_PROCESS_EXECUTABLE']))
);

WR7: NOT (SELF.description = 'selective') OR
((2 <= get_count_of_relating_amr (SELF,
['INTEGRATED_CNC_SCHEMA.MACHINING_PROCESS_BRANCH_RELATIONSHIP'])) AND
(verify_related_type_for_amr (SELF,
['INTEGRATED_CNC_SCHEMA.MACHINING_PROCESS_BRANCH_RELATIONSHIP'],
['INTEGRATED_CNC_SCHEMA.MACHINING_PROCESS_EXECUTABLE']))
);

WR8: NOT (SELF.description = 'setup instructions') OR
((verify_related_type_for_amr (SELF,
['INTEGRATED_CNC_SCHEMA.MACHINING_OPERATOR_INSTRUCTION_RELATIONSHIP'],
['INTEGRATED_CNC_SCHEMA.MACHINING_OPERATOR_INSTRUCTION']))
);

```

ISO 10303-238:2007(E)

```

END_ENTITY; -- 10303-238: integrated_cnc_schema

ENTITY machining_process_model
  SUBTYPE OF (action_method);
  WHERE
    WR1: (verify_required_action_property (SELF, 'initialization data')) AND
          (verify_descriptive_action_property (SELF, 'initialization data'));
END_ENTITY; -- 10303-238: integrated_cnc_schema

ENTITY machining_process_model_relationship
  SUBTYPE OF (sequential_method);
END_ENTITY; -- 10303-238: integrated_cnc_schema

ENTITY machining_process_sequence_relationship
  SUBTYPE OF (machining_process_body_relationship, sequential_method);
END_ENTITY; -- 10303-238: integrated_cnc_schema

ENTITY machining_project
  SUBTYPE OF (product);
  WHERE
    WR1: (0 = SIZEOF (QUERY (pdf <* USEDIN (SELF,
      'INTEGRATED_CNC_SCHEMA.' +
      'PRODUCT_DEFINITION_FORMATION.OF_PRODUCT') | NOT

      -- it has at most one associated owner.
      (1 >= SIZEOF (QUERY (poa <* USEDIN (pdf,
        'INTEGRATED_CNC_SCHEMA.' +
        'APPLIED_PERSON_AND_ORGANIZATION_ASSIGNMENT.ITEMS') |
        (poa.role.name = 'owner'))))
    )))

    WR2: (0 = SIZEOF (QUERY (pdf <* USEDIN (SELF,
      'INTEGRATED_CNC_SCHEMA.' +
      'PRODUCT_DEFINITION_FORMATION.OF_PRODUCT') | NOT

      -- it has at most one associated release date.
      (1 >= SIZEOF (QUERY (dta <* USEDIN (pdf,
        'INTEGRATED_CNC_SCHEMA.' +
        'APPLIED_DATE_AND_TIME_ASSIGNMENT.ITEMS') |
        (dta.role.name = 'release date'))))
    )))

    WR3: (0 = SIZEOF (QUERY (pdf <* USEDIN (SELF,
      'INTEGRATED_CNC_SCHEMA.' +
      'PRODUCT_DEFINITION_FORMATION.OF_PRODUCT') | NOT

      (0 = SIZEOF (QUERY (pd <* USEDIN (pdf,
        'INTEGRATED_CNC_SCHEMA.PRODUCT_DEFINITION.FORMATION') | NOT

      -- it has one associated workplan.
      (1 = SIZEOF (QUERY (ppa <* USEDIN (pd,
        'INTEGRATED_CNC_SCHEMA.' +

```

```

        'PROCESS_PRODUCT_ASSOCIATION.DEFINED_PRODUCT') |
        (ppa.process.name = 'machining') AND
        ('INTEGRATED_CNC_SCHEMA.MACHINING_WORKPLAN'
         IN TYPEOF (ppa.process.chosen_method))))
    )))
    ));
END_ENTITY; -- 10303-238: integrated_cnc_schema

ENTITY machining_project_workpiece_relationship
  SUBTYPE OF (product_definition_relationship);
END_ENTITY; -- 10303-238: integrated_cnc_schema

ENTITY machining_rapid_movement
  SUBTYPE OF (machining_process_executable, machining_operation);
  WHERE
  WR1: ((verify_required_action_property      (SELF, 'security plane')) AND
        (verify_rep_item_for_action_property  (SELF, 'security plane',
        ['INTEGRATED_CNC_SCHEMA.ELEMENTARY_SURFACE'])));
END_ENTITY; -- 10303-238: integrated_cnc_schema

ENTITY machining_setup
  SUBTYPE OF (product);
  WHERE
  WR1: (0 = SIZEOF (QUERY (pdf <* USEDIN (SELF,
    'INTEGRATED_CNC_SCHEMA.' +
    'PRODUCT_DEFINITION_FORMATION.OF_PRODUCT') | NOT

    (0 = SIZEOF (QUERY (pd <* USEDIN (pdf,
    'INTEGRATED_CNC_SCHEMA.PRODUCT_DEFINITION.FORMATION') | NOT

    -- it has one associated security plane.
    (1 = SIZEOF (QUERY (prop <* USEDIN (pd,
    'INTEGRATED_CNC_SCHEMA.PROPERTY_DEFINITION.DEFINITION') |
    (prop.name = 'security plane'))))
    )))
    ));
END_ENTITY; -- 10303-238: integrated_cnc_schema

ENTITY machining_setup_workpiece_relationship
  SUBTYPE OF (product_definition_relationship);
END_ENTITY; -- 10303-238: integrated_cnc_schema

ENTITY machining_spindle_speed_representation
  SUBTYPE OF (representation);
  WHERE
  WR1: (SELF.name IN ['spindle speed', 'cutting speed', 'relative speed']);

  WR2: NOT (SELF.name = 'spindle speed') OR
        ((verify_required_rep_item      (SELF, 'rotational speed')) AND
         (verify_rotary_speed_measure_rep_item (SELF, 'rotational speed'))
        );

  WR3: NOT (SELF.name = 'cutting speed') OR
        ((verify_required_rep_item      (SELF, 'surface speed')) AND

```

```

        (verify_linear_speed_measure_rep_item (SELF, 'surface speed')) AND

        (verify_optional_rep_item
          (SELF, 'maximum rotational speed')) AND
        (verify_rotary_speed_measure_rep_item
          (SELF, 'maximum rotational speed'))
      );

WR4: NOT (SELF.name = 'relative speed') OR
      ((verify_required_rep_item           (SELF, 'relative speed')) AND
       (verify_ratio_measure_rep_item      (SELF, 'relative speed'))
      );
END_ENTITY; -- 10303-238: integrated_cnc_schema

ENTITY machining_strategy
  SUBTYPE OF (action_method);
END_ENTITY; -- 10303-238: integrated_cnc_schema

ENTITY machining_strategy_relationship
  SUBTYPE OF (action_method_relationship);
END_ENTITY; -- 10303-238: integrated_cnc_schema

ENTITY machining_technology
  SUBTYPE OF (action_method);
  WHERE
WR1: (verify_optional_action_property      (SELF, 'feedrate')) AND
      (verify_rep_type_for_action_property (SELF, 'feedrate',
        ['INTEGRATED_CNC_SCHEMA.MACHINING_FEED_SPEED_REPRESENTATION']));

WR2: (verify_optional_action_property      (SELF, 'feedrate reference')) AND
      (verify_enumeration_action_property  (SELF, 'feedrate reference',
        ['tool center point', 'cutter contact point']));

WR3: NOT (SELF.description = 'milling') OR
      ((verify_optional_action_property      (SELF, 'spindle')) AND
       (verify_rep_type_for_action_property (SELF, 'spindle',
        ['INTEGRATED_CNC_SCHEMA.MACHINING_SPINDLE_SPEED_REPRESENTATION'])) AND

      (verify_optional_action_property
        (SELF, 'synchronize spindle with feed')) AND
      (verify_enumeration_action_property
        (SELF, 'synchronize spindle with feed',
        ['synchronized', 'not synchronized'])) AND

      (verify_optional_action_property
        (SELF, 'inhibit feedrate override')) AND
      (verify_enumeration_action_property
        (SELF, 'inhibit feedrate override',
        ['override allowed', 'override not allowed'])) AND

      (verify_optional_action_property
        (SELF, 'inhibit spindle override')) AND
      (verify_enumeration_action_property
        (SELF, 'inhibit spindle override',

```

```

        ['override allowed', 'override not allowed'])) AND

    (verify_optional_relatng_amr (SELF,
        ['INTEGRATED_CNC_SCHEMA.MACHINING_ADAPTIVE_CONTROL_RELATIONSHIP']))
AND
    (verify_related_type_for_amr (SELF,
        ['INTEGRATED_CNC_SCHEMA.MACHINING_ADAPTIVE_CONTROL_RELATIONSHIP'],
        ['INTEGRATED_CNC_SCHEMA.MACHINING_TECHNOLOGY']))
);

WR4: NOT (SELF.description = 'milling') OR
    ((verify_required_relatng_amr (SELF,
        ['INTEGRATED_CNC_SCHEMA.MACHINING_ADAPTIVE_CONTROL_RELATIONSHIP'])) OR

        (verify_required_action_property (SELF, 'spindle') AND
        verify_rep_name_for_action_property (SELF, 'spindle',
            ['spindle speed', 'cutting speed']))
    );

WR5: NOT (SELF.description = 'milling') OR
    ((verify_required_relatng_amr (SELF,
        ['INTEGRATED_CNC_SCHEMA.MACHINING_ADAPTIVE_CONTROL_RELATIONSHIP'])) OR

        (verify_required_action_property (SELF, 'feedrate') AND
        verify_rep_name_for_action_property (SELF, 'feedrate',
            ['feed speed', 'feed per tooth']))
    );

WR6: NOT (SELF.description = 'turning') OR
    ((verify_optional_action_property (SELF, 'spindle')) AND
    (verify_rep_type_for_action_property (SELF, 'spindle',
        ['INTEGRATED_CNC_SCHEMA.MACHINING_SPINDLE_SPEED_REPRESENTATION'])) AND
    (verify_rep_name_for_action_property (SELF, 'spindle',
        ['spindle speed', 'cutting speed'])) AND

        (verify_rep_name_for_action_property (SELF, 'feedrate',
            ['feed speed', 'feed per revolution'])) AND

        (verify_optional_action_property
            (SELF, 'synchronize spindle with z feed')) AND
        (verify_enumeration_action_property
            (SELF, 'synchronize spindle with z feed',
                ['synchronized', 'not synchronized'])) AND

        (verify_optional_action_property
            (SELF, 'inhibit feedrate override')) AND
        (verify_enumeration_action_property
            (SELF, 'inhibit feedrate override',
                ['override allowed', 'override not allowed'])) AND

        (verify_optional_action_property
            (SELF, 'inhibit spindle override')) AND
        (verify_enumeration_action_property
            (SELF, 'inhibit spindle override',

```

```

        ['override allowed', 'override not allowed'])) AND

    (verify_optional_relatng_amr (SELF,
        ['INTEGRATED_CNC_SCHEMA.MACHINING_ADAPTIVE_CONTROL_RELATIONSHIP']))
AND
    (verify_related_type_for_amr (SELF,
        ['INTEGRATED_CNC_SCHEMA.MACHINING_ADAPTIVE_CONTROL_RELATIONSHIP'],
        ['INTEGRATED_CNC_SCHEMA.MACHINING_TECHNOLOGY']))
    );
END_ENTITY; -- 10303-238: integrated_cnc_schema

ENTITY machining_technology_relationship
    SUBTYPE OF (action_method_relationship);
END_ENTITY; -- 10303-238: integrated_cnc_schema

ENTITY machining_tool
    SUBTYPE OF (action_resource);
    WHERE
    WR1: NOT (SELF.kind.name = 'milling cutting tool') OR
        ((0 <= SIZEOF (QUERY (arr <* USEDIN (SELF,
'INTEGRATED_CNC_SCHEMA.ACTION_RESOURCE_RELATIONSHIP.RELATNG_RESOURCE') |
        (('INTEGRATED_CNC_SCHEMA.MACHINING_CUTTING_COMPONENT'
            IN TYPEOF (arr.related_resource)) AND
            (arr.related_resource.kind.name = 'milling cutting edge') )))) AND

    (verify_optional_tool_body_item
        (SELF, 'overall assembly length')) AND
    (verify_length_measure_tool_body_item
        (SELF, 'overall assembly length')) AND

    (verify_optional_tool_body_item
        (SELF, 'effective cutting diameter')) AND
    (verify_length_measure_tool_body_item
        (SELF, 'effective cutting diameter')) AND

    (verify_optional_tool_body_item
        (SELF, 'maximum depth of cut')) AND
    (verify_length_measure_tool_body_item
        (SELF, 'maximum depth of cut')) AND

    (verify_optional_tool_body_item (SELF, 'hand of cut')) AND
    (verify_enumeration_tool_body_item (SELF, 'hand of cut',
        ['left', 'right', 'neutral'])) AND

    (verify_optional_tool_body_item (SELF, 'coolant through tool')) AND
    (verify_enumeration_tool_body_item (SELF, 'coolant through tool',
        ['supported', 'not supported']))
    );

    WR2: NOT ((SELF.kind.name = 'milling cutting tool') AND
        (SELF.description IN [ 'counterbore', 'countersink',
            'spade drill', 'spot drill', 'step drill', 'tapered drill',
            'twist drill', 'drill']))

```



```

OR
((verify_optional_tool_body_item      (SELF, 'point angle')) AND
 (verify_angle_measure_tool_body_item (SELF, 'point angle'))
);

WR3: NOT ((SELF.kind.name = 'milling cutting tool') AND
 (SELF.description = 'countersink'))
OR
((verify_optional_tool_body_item
 (SELF, 'minimum cutting diameter')) AND
 (verify_length_measure_tool_body_item
 (SELF, 'minimum cutting diameter')) AND

 (verify_required_tool_body_item
 (SELF, 'maximum usable length')) AND
 (verify_length_measure_tool_body_item
 (SELF, 'maximum usable length'))
);

WR4: NOT ((SELF.kind.name = 'milling cutting tool') AND
 (SELF.description = 'tapered drill'))
OR
((verify_required_tool_body_item      (SELF, 'taper angle')) AND
 (verify_angle_measure_tool_body_item (SELF, 'taper angle'))
);

-- Could make this stronger if we want
WR5: NOT ((SELF.kind.name = 'milling cutting tool') AND
 (SELF.description = 'step drill'))
OR
((verify_required_tool_body_item      (SELF, 'step diameters')) AND
 (verify_rep_item_for_tool_body
 (SELF, 'step diameters',
 ['INTEGRATED_CNC_SCHEMA.COMPOUND_REPRESENTATION_ITEM'])) AND

 (verify_required_tool_body_item      (SELF, 'step lengths')) AND
 (verify_rep_item_for_tool_body
 (SELF, 'step lengths',
 ['INTEGRATED_CNC_SCHEMA.COMPOUND_REPRESENTATION_ITEM']))
);

WR6: NOT ((SELF.kind.name = 'milling cutting tool') AND
 (SELF.description IN [ 'ballnose endmill', 'bullnose endmill',
 'dovetail mill', 'endmill', 'facemill', 'profiled endmill',
 'shoulder mill', 'tee slot mill', 'thread mill', 'side mill']))
OR
((verify_optional_tool_body_item
 (SELF, 'number of effective teeth')) AND
 (verify_count_measure_tool_body_item
 (SELF, 'number of effective teeth')) AND

 (verify_optional_tool_body_item      (SELF, 'edge radius')) AND
 (verify_length_measure_tool_body_item (SELF, 'edge radius'))

```

```

);

WR7: NOT ((SELF.kind.name = 'milling cutting tool') AND
(SELF.description IN [ 'ballnose endmill', 'bullnose endmill',
'endmill', 'facemill', 'profiled endmill']))
OR
((verify_optional_tool_body_item
(SELF, 'tool cutting edge angle')) AND
(verify_angle_measure_tool_body_item
(SELF, 'tool cutting edge angle'))
);

WR8: NOT ((SELF.kind.name = 'milling cutting tool') AND
(SELF.description = 'ballnose endmill'))
OR verify_ballnose_endmill_dimensions (SELF);

WR9: NOT ((SELF.kind.name = 'milling cutting tool') AND
(SELF.description = 'bullnose endmill'))
OR verify_bullnose_endmill_dimensions (SELF);

WR10: NOT ((SELF.kind.name = 'milling cutting tool') AND
(SELF.description = 'tee slot mill'))
OR
((verify_optional_tool_body_item (SELF, 'cutting width')) AND
(verify_length_measure_tool_body_item (SELF, 'cutting width'))
);

WR11: NOT ((SELF.kind.name = 'milling cutting tool') AND
(SELF.description = 'dovetail mill'))
OR
((verify_optional_tool_body_item (SELF, 'included angle')) AND
(verify_angle_measure_tool_body_item (SELF, 'included angle'))
);

WR12: NOT ((SELF.kind.name = 'milling cutting tool') AND
(SELF.description = 'side mill'))
OR
((verify_optional_tool_body_item (SELF, 'cutter width')) AND
(verify_length_measure_tool_body_item (SELF, 'cutter width'))
);

WR13: NOT ((SELF.kind.name = 'milling cutting tool') AND
(SELF.description IN [ 'thread mill', 'tapping tool',
'combined drill and tap']))
OR
((verify_required_tool_body_item (SELF, 'thread form type')) AND
(verify_rep_item_for_tool_body (SELF, 'thread form type',
['INTEGRATED_CNC_SCHEMA.DESRIPTIVE_REPRESENTATION_ITEM'])) AND

(verify_required_tool_body_item (SELF, 'thread size')) AND
(verify_length_measure_tool_body_item (SELF, 'thread size')) AND

(verify_required_tool_body_item (SELF, 'thread pitch')) AND

```

```
(verify_length_measure_tool_body_item (SELF, 'thread pitch'))
);
```

```
WR14: NOT ((SELF.kind.name = 'milling cutting tool') AND
(SSELF.description IN [ 'tapping tool', 'combined drill and tap']))
OR
((verify_required_tool_body_item
  (SELF, 'taper thread count')) AND
(verify_count_measure_tool_body_item
  (SELF, 'taper thread count'))
);
```

```
WR15: NOT ((SELF.kind.name = 'milling cutting tool') AND
(SSELF.description IN [ 'reamer', 'combined drill and reamer',
'tapered reamer']))
OR
((verify_required_tool_body_item      (SELF, 'taper length')) AND
(verify_length_measure_tool_body_item (SELF, 'taper length'))
);
```

```
WR16: NOT ((SELF.kind.name = 'milling cutting tool') AND
(SSELF.description = 'tapered reamer'))
OR
((verify_required_tool_body_item      (SELF, 'taper angle')) AND
(verify_angle_measure_tool_body_item (SELF, 'taper angle'))
);
```

```
WR17: NOT ((SELF.kind.name = 'milling cutting tool') AND
(SSELF.description IN [ 'combined drill and reamer',
'combined drill and tap']))
OR
((verify_required_tool_body_item      (SELF, 'drill length')) AND
(verify_length_measure_tool_body_item (SELF, 'drill length'))
);
```

```
WR18: NOT ((SELF.kind.name = 'milling cutting tool') AND
(SSELF.description = 'boring tool'))
OR
((verify_required_tool_body_item      (SELF, 'retract movement')) AND
(verify_enumeration_tool_body_item (SELF, 'retract movement',
['permitted', 'forbidden']))
);
```

```
WR19: NOT ((SELF.kind.name = 'milling cutting tool') AND
(SSELF.description = 'user defined milling tool'))
OR
((verify_optional_tool_body_item      (SELF, 'tool description')) AND
(verify_rep_item_for_tool_body      (SELF, 'tool description',
['INTEGRATED_CNC_SCHEMA.DESCRPTIVE_REPRESENTATION_ITEM'])) AND
(verify_optional_tool_body_item
```

```

        (SELF, 'corner radius')) AND
    (verify_length_measure_tool_body_item
        (SELF, 'corner radius')) AND

    (verify_optional_tool_body_item
        (SELF, 'corner radius center horizontal')) AND
    (verify_length_measure_tool_body_item
        (SELF, 'corner radius center horizontal')) AND

    (verify_optional_tool_body_item
        (SELF, 'corner radius center vertical')) AND
    (verify_length_measure_tool_body_item
        (SELF, 'corner radius center vertical')) AND

    (verify_optional_tool_body_item      (SELF, 'taper angle')) AND
    (verify_angle_measure_tool_body_item (SELF, 'taper angle')) AND

    (verify_optional_tool_body_item      (SELF, 'tip outer angle')) AND
    (verify_angle_measure_tool_body_item (SELF, 'tip outer angle'))
);

WR20: NOT (SELF.kind.name = 'turning cutting tool') OR
((verify_required_tool_body_item      (SELF, 'functional length')) AND
 (verify_length_measure_tool_body_item (SELF, 'functional length')) AND

 (verify_required_tool_body_item      (SELF, 'f dimension')) AND
 (verify_length_measure_tool_body_item (SELF, 'f dimension')) AND

 (verify_optional_tool_body_item
     (SELF, 'minimum cutting diameter')) AND
 (verify_length_measure_tool_body_item
     (SELF, 'minimum cutting diameter')) AND

 (verify_optional_tool_body_item
     (SELF, 'a dimension on f')) AND
 (verify_length_measure_tool_body_item
     (SELF, 'a dimension on f')) AND

 (verify_optional_tool_body_item
     (SELF, 'a dimension on lf')) AND
 (verify_length_measure_tool_body_item
     (SELF, 'a dimension on lf')) AND

 (verify_optional_tool_body_item      (SELF, 'hand of cut')) AND
 (verify_enumeration_tool_body_item (SELF, 'hand of cut',
     ['left', 'right', 'neutral'])) AND

 (0 <= SIZEOF (QUERY (arr <* USEDIN (SELF,
'INTEGRATED_CNC_SCHEMA.ACTION_RESOURCE_RELATIONSHIP.RELATING_RESOURCE') |
    (('INTEGRATED_CNC_SCHEMA.MACHINING_CUTTING_COMPONENT'
     IN TYPEOF (arr.related_resource)) AND
     (arr.related_resource.kind.name = 'turning cutting edge') ))))
);

```

```

WR21: NOT ((SELF.kind.name = 'turning cutting tool') AND
  (SELF.description = 'turning threading tool'))
OR
((verify_required_tool_body_item      (SELF, 'thread pitch')) AND
  (verify_length_measure_tool_body_item (SELF, 'thread pitch')) AND

  (verify_required_tool_body_item      (SELF, 'thread hand')) AND
  (verify_enumeration_tool_body_item   (SELF, 'thread hand',
    ['left', 'right'])) AND

  (verify_required_tool_body_item      (SELF, 'thread type')) AND
  (verify_enumeration_tool_body_item   (SELF, 'thread type',
    ['internal', 'external'])) AND

  (verify_required_tool_body_item      (SELF, 'thread profile')) AND
  (verify_enumeration_tool_body_item   (SELF, 'thread profile',
    ['full', 'partial'])) AND

  (verify_required_tool_body_item      (SELF, 'thread form type')) AND
  (verify_rep_item_for_tool_body       (SELF, 'thread form type',
    ['INTEGRATED_CNC_SCHEMA.DESRIPTIVE_REPRESENTATION_ITEM']))
);

```

```

WR22: NOT ((SELF.kind.name = 'turning cutting tool') AND
  (SELF.description = 'grooving tool'))
OR
((verify_required_tool_body_item      (SELF, 'cutting width')) AND
  (verify_length_measure_tool_body_item (SELF, 'cutting width')) AND

  (verify_required_tool_body_item      (SELF, 'maximum grooving depth')) AND
  (verify_length_measure_tool_body_item (SELF, 'maximum grooving depth')) AND

  (verify_optional_tool_body_item      (SELF, 'corner radius')) AND
  (verify_length_measure_tool_body_item (SELF, 'corner radius')) AND

  (verify_optional_tool_body_item      (SELF, 'maximum axial grooving diameter')) AND
  (verify_length_measure_tool_body_item (SELF, 'maximum axial grooving diameter')) AND

  (verify_optional_tool_body_item      (SELF, 'minimum axial grooving diameter')) AND
  (verify_length_measure_tool_body_item (SELF, 'minimum axial grooving diameter'))
);

```

```

WR23: NOT ((SELF.kind.name = 'turning cutting tool') AND

```

```

(SELF.description = 'knurling tool'))
OR
((verify_required_tool_body_item (SELF, 'knurl pattern')) AND
 (verify_enumeration_tool_body_item (SELF, 'knurl pattern',
   ['straight', 'diagonal', 'diamond'])) AND

 (verify_optional_tool_body_item (SELF, 'cutting length')) AND
 (verify_length_measure_tool_body_item (SELF, 'cutting length')) AND

 (verify_optional_tool_body_item (SELF, 'cutting angle')) AND
 (verify_angle_measure_tool_body_item (SELF, 'cutting angle')) AND

 (verify_optional_tool_body_item (SELF, 'cutting pitch')) AND
 (verify_length_measure_tool_body_item (SELF, 'cutting pitch'))
);

WR24: NOT ((SELF.kind.name = 'turning cutting tool') AND
 (SELF.description = 'user defined turning tool'))
OR
((verify_required_tool_body_item (SELF, 'tool identifier')) AND
 (verify_rep_item_for_tool_body (SELF, 'tool identifier',
   ['INTEGRATED_CNC_SCHEMA.DESRIPTIVE_REPRESENTATION_ITEM']))
);

WR25: (1 >= SIZEOF (QUERY (rar <* USEDIN (SELF,
   'INTEGRATED_CNC_SCHEMA.REQUIREMENT_FOR_ACTION_RESOURCE.RESOURCES') |
 (1 = SIZEOF(rar.operations)) AND
 ('INTEGRATED_CNC_SCHEMA.MACHINING_TOOL_USAGE'
   IN TYPEOF (rar\action_resource_requirement.operations[1])))
));
END_ENTITY; -- 10303-238: integrated_cnc_schema

ENTITY machining_tool_body_representation
  SUBTYPE OF (representation);
END_ENTITY; -- 10303-238: integrated_cnc_schema

ENTITY machining_tool_direction_representation
  SUBTYPE OF (representation);
  WHERE
  WR1: (SELF.name IN ['two axes', 'three axes', 'three axes tilted tool',
    'five axes const tilt yaw', 'five axes var tilt yaw']);

  WR2: NOT (SELF.name = 'three axes tilted tool') OR
    ((verify_required_rep_item (SELF, 'tool direction orientation'))
AND
    (0 = SIZEOF (QUERY ( it <* SELF.items |
      (it.name = 'tool direction orientation') AND NOT
      ('INTEGRATED_CNC_SCHEMA.DIRECTION' IN TYPEOF(it)))))
    );

  WR3: NOT (SELF.name = 'five axes const tilt yaw') OR
    ((verify_required_rep_item (SELF, 'tool direction tilt angle')) AND
    (verify_angle_measure_rep_item (SELF, 'tool direction tilt angle'))

```

```

AND
    (verify_required_rep_item      (SELF, 'tool direction yaw angle')) AND
    (verify_angle_measure_rep_item (SELF, 'tool direction yaw angle'))
);
END_ENTITY; -- 10303-238: integrated_cnc_schema

ENTITY machining_tool_usage
  SUBTYPE OF (action_method);
  WHERE
  WR1: ((verify_optional_action_property (SELF, 'tool position')) AND
        (verify_descriptive_action_property (SELF, 'tool position')) AND

        (verify_optional_action_property (SELF, 'tool carousel')) AND
        (verify_descriptive_action_property (SELF, 'tool carousel'))
        );
END_ENTITY; -- 10303-238: integrated_cnc_schema

ENTITY machining_toolpath
  SUBTYPE OF (action_method);
  WHERE
  WR1: (SELF.description IN ['feedstop', 'axis trajectory',
                             'cutter location trajectory', 'cutter contact trajectory',
                             'approach lift path angle', 'approach lift path tangent',
                             'connect security plane', 'connect direct']);

  WR2: (verify_optional_action_property (SELF, 'priority')) AND
        (verify_enumeration_action_property (SELF, 'priority',
        ['required', 'suggested']));

  WR3: (verify_optional_action_property (SELF, 'trajectory type')) AND
        (verify_enumeration_action_property (SELF, 'trajectory type',
        ['approach', 'lift', 'connect', 'non-contact',
        'contact', 'trajectory path']));

  WR4: ((verify_optional_action_property (SELF, 'speed profile')) AND
        (0 = SIZEOF (QUERY (prop <*
        get_action_property (SELF, 'speed profile') | NOT
        (0 < SIZEOF (QUERY (prep <* USEDIN (prop,
        'INTEGRATED_CNC_SCHEMA.' +
        'ACTION_PROPERTY_REPRESENTATION.PROPERTY') |
        ('INTEGRATED_CNC_SCHEMA.' +
        'MACHINING_TOOLPATH_SPEED_PROFILE_REPRESENTATION'
        IN TYPEOF(prep.representation)) )))
        )))
);

  WR5: (verify_optional_relating_amr (SELF,
        ['INTEGRATED_CNC_SCHEMA.MACHINING_TECHNOLOGY_RELATIONSHIP'])) AND
        (verify_related_type_for_amr (SELF,
        ['INTEGRATED_CNC_SCHEMA.MACHINING_TECHNOLOGY_RELATIONSHIP'],
        ['INTEGRATED_CNC_SCHEMA.MACHINING_TECHNOLOGY']));

  WR6: (verify_optional_relating_amr (SELF,

```





```

WR12: NOT (SELF.description = 'approach lift path angle') OR
  ((verify_required_action_property      (SELF, 'angle')) AND
   (verify_angle_measure_action_property (SELF, 'angle')) AND

   (verify_required_action_property      (SELF, 'bend distance')) AND
   (verify_length_measure_action_property (SELF, 'bend distance'))
  );

WR13: NOT (SELF.description = 'approach lift path tangent') OR
  ((verify_required_action_property      (SELF, 'radius')) AND
   (verify_length_measure_action_property (SELF, 'radius'))
  );

WR14: NOT (SELF.description = 'cutter location trajectory') OR
  ((verify_required_action_property      (SELF, 'basic curve')) AND
   (verify_rep_item_for_action_property (SELF, 'basic curve',
     ['INTEGRATED_CNC_SCHEMA.BOUNDED_CURVE'])) AND

   (verify_optional_action_property      (SELF, 'surface normal')) AND
   (verify_rep_item_for_action_property (SELF, 'surface normal',
     ['INTEGRATED_CNC_SCHEMA.BOUNDED_CURVE'])) AND

   (verify_optional_action_property      (SELF, 'tool axis')) AND
   (verify_rep_item_for_action_property (SELF, 'tool axis',
     ['INTEGRATED_CNC_SCHEMA.BOUNDED_CURVE'])) AND

   (verify_optional_action_property
     (SELF, 'path maximum deviation')) AND
   (verify_length_measure_action_property
     (SELF, 'path maximum deviation')) AND

   (verify_optional_action_property
     (SELF, 'tool axis maximum deviation')) AND
   (verify_angle_measure_action_property
     (SELF, 'tool axis maximum deviation'))
  );

WR15: NOT (SELF.description = 'cutter contact trajectory') OR
  (((verify_required_action_property      (SELF, 'basic curve')) AND
   (verify_rep_item_for_action_property (SELF, 'basic curve',
     ['INTEGRATED_CNC_SCHEMA.BOUNDED_PCURVE']))) )

  OR

  ((verify_required_action_property      (SELF, 'basic curve')) AND
   (verify_rep_item_for_action_property (SELF, 'basic curve',
     ['INTEGRATED_CNC_SCHEMA.BOUNDED_CURVE'])) AND

   (verify_required_action_property      (SELF, 'surface normal')) AND
   (verify_rep_item_for_action_property (SELF, 'surface normal',
     ['INTEGRATED_CNC_SCHEMA.BOUNDED_CURVE']))) )
  ) AND

```

```

    (verify_optional_action_property      (SELF, 'tool axis')) AND
    (verify_rep_item_for_action_property (SELF, 'tool axis',
      ['INTEGRATED_CNC_SCHEMA.BOUNDED_CURVE'])) AND

    (verify_optional_action_property      (SELF, 'contact type')) AND
    (verify_enumeration_action_property  (SELF, 'contact type',
      ['side', 'front'])) AND

    (verify_optional_action_property
      (SELF, 'path maximum deviation')) AND
    (verify_length_measure_action_property
      (SELF, 'path maximum deviation')) AND

    (verify_optional_action_property
      (SELF, 'tool axis maximum deviation')) AND
    (verify_angle_measure_action_property
      (SELF, 'tool axis maximum deviation'))
  );

  WR16: NOT (SELF.description IN ['axis trajectory',
    'cutter location trajectory',
    'cutter contact trajectory']) OR
  ((verify_optional_action_property
    (SELF, 'material removal depth')) AND
  ((verify_length_measure_action_property
    (SELF, 'material removal depth')) OR
  (verify_rep_item_for_action_property
    (SELF, 'material removal depth',
      ['INTEGRATED_CNC_SCHEMA.BOUNDED_CURVE']))) AND

  (verify_optional_action_property
    (SELF, 'material removal overcut')) AND
  ((verify_length_measure_action_property
    (SELF, 'material removal overcut')) OR
  (verify_rep_item_for_action_property
    (SELF, 'material removal overcut',
      ['INTEGRATED_CNC_SCHEMA.BOUNDED_CURVE']))) AND

  (verify_optional_action_property
    (SELF, 'material removal total volume')) AND
  (verify_rep_item_for_action_property
    (SELF, 'material removal total volume',
      ['INTEGRATED_CNC_SCHEMA.MEASURE_REPRESENTATION_ITEM']))
  );

  END_ENTITY; -- 10303-238: integrated_cnc_schema

  ENTITY machining_toolpath_sequence_relationship
    SUBTYPE OF (sequential_method);
  END_ENTITY; -- 10303-238: integrated_cnc_schema

  ENTITY machining_toolpath_speed_profile_representation
    SUBTYPE OF (representation);
  WHERE

```

```

WR1: (1 = SIZEOF (QUERY ( it <* SELF.items |
  ( (('INTEGRATED_CNC_SCHEMA.BOUNDED_CURVE'
    IN TYPEOF(it))) OR

    (('INTEGRATED_CNC_SCHEMA.DESRIPTIVE_REPRESENTATION_ITEM'
    IN TYPEOF(it)) AND
    (it.description IN ['rapid']))) OR

    ((SIZEOF([
      'INTEGRATED_CNC_SCHEMA.MEASURE_REPRESENTATION_ITEM',
      'INTEGRATED_CNC_SCHEMA.RATIO_MEASURE_WITH_UNIT'] *
      TYPEOF(it)) = 2))
    )
  )))
END_ENTITY; -- 10303-238: integrated_cnc_schema

ENTITY machining_touch_probing
  SUBTYPE OF (machining_process_executable, machining_operation);
  WHERE
  WR1: (SELF.description IN ['tool length probing', 'tool radius probing',
    'workpiece probing', 'workpiece complete probing']);

  WR2: ((verify_required_action_property      (SELF, 'security plane')) AND
    (verify_rep_item_for_action_property      (SELF, 'security plane',
    ['INTEGRATED_CNC_SCHEMA.ELEMENTARY_SURFACE'])));

  WR3: ((verify_required_action_property      (SELF, 'measured offset')) AND
    (verify_rep_item_for_action_property      (SELF, 'measured offset',
    ['INTEGRATED_CNC_SCHEMA.EXPRESSION_REPRESENTATION_ITEM',
    'INTEGRATED_CNC_SCHEMA.NUMERIC_VARIABLE'])));

  WR4: NOT (SELF.description = 'workpiece probing') OR
    ((verify_required_action_property      (SELF, 'start position')) AND
    (verify_rep_item_for_action_property      (SELF, 'start position',
    ['INTEGRATED_CNC_SCHEMA.AXIS2_PLACEMENT_3D'])) AND

    (1 = SIZEOF (QUERY (act <*
      USEDIN (SELF, 'INTEGRATED_CNC_SCHEMA.ACTION.CHOSEN_METHOD') |
      (act.name = 'workpiece probing')))) AND
    (0 = SIZEOF (QUERY (act <*
      USEDIN (SELF, 'INTEGRATED_CNC_SCHEMA.ACTION.CHOSEN_METHOD') |
      (act.name = 'workpiece probing') AND NOT
      ('INTEGRATED_CNC_SCHEMA.PRODUCT_DEFINITION_PROCESS'
      IN TYPEOF (act)))))) AND

    (verify_required_action_property      (SELF, 'direction')) AND
    (verify_rep_item_for_action_property      (SELF, 'direction',
    ['INTEGRATED_CNC_SCHEMA.DIRECTION'])) AND

    (verify_required_action_property      (SELF, 'expected value')) AND
    (verify_rep_item_for_action_property      (SELF, 'expected value',
    ['INTEGRATED_CNC_SCHEMA.LENGTH_MEASURE_WITH_UNIT',
    'INTEGRATED_CNC_SCHEMA.MEASURE_REPRESENTATION_ITEM',
    'INTEGRATED_CNC_SCHEMA.QUALIFIED_REPRESENTATION_ITEM'])) AND

```

```

        (verify_required_action_property      (SELF, 'probe'))
    );

WR5: NOT (SELF.description = 'workpiece complete probing') OR
((1 = SIZEOF (QUERY (act <*
    USEDIN (SELF, 'INTEGRATED_CNC_SCHEMA.ACTION.CHOSEN_METHOD') |
    (act.name = 'workpiece complete probing')))) AND
(0 = SIZEOF (QUERY (act <*
    USEDIN (SELF, 'INTEGRATED_CNC_SCHEMA.ACTION.CHOSEN_METHOD') |
    (act.name = 'workpiece complete probing') AND NOT
    ('INTEGRATED_CNC_SCHEMA.PRODUCT_DEFINITION_PROCESS'
    IN TYPEOF (act))))) AND

(verify_required_action_property      (SELF, 'probing distance')) AND
(verify_rep_item_for_action_property  (SELF, 'probing distance',
    ['INTEGRATED_CNC_SCHEMA.LENGTH_MEASURE_WITH_UNIT',
    'INTEGRATED_CNC_SCHEMA.MEASURE_REPRESENTATION_ITEM',
    'INTEGRATED_CNC_SCHEMA.QUALIFIED_REPRESENTATION_ITEM'])) AND

(verify_required_action_property      (SELF, 'probe')) AND

(verify_required_action_property      (SELF, 'computed offset')) AND
(verify_rep_type_for_action_property  (SELF, 'computed offset',
    ['INTEGRATED_CNC_SCHEMA.MACHINING_OFFSET_VECTOR_REPRESENTATION']))
);

WR6: NOT (SELF.description IN ['tool length probing',
    'tool radius probing']) OR
((verify_required_action_property      (SELF, 'offset')) AND
(verify_rep_item_for_action_property  (SELF, 'offset',
    ['INTEGRATED_CNC_SCHEMA.CARTESIAN_POINT'])) AND

(verify_required_action_property      (SELF, 'maximum wear')) AND
(verify_length_measure_action_property (SELF, 'maximum wear')) AND

(1 = SIZEOF (QUERY (mt <*
    USEDIN (SELF, 'INTEGRATED_CNC_SCHEMA.ACTION_RESOURCE.USAGE') |
    ('INTEGRATED_CNC_SCHEMA.MACHINING_TOOL' in TYPEOF(mt)))))
);
END_ENTITY; -- 10303-238: integrated_cnc_schema

ENTITY machining_workingstep
    SUBTYPE OF (machining_process_executable);
    WHERE
    WR1: ((verify_optional_action_property      (SELF, 'security plane')) AND
    (verify_rep_item_for_action_property (SELF, 'security plane',
    ['INTEGRATED_CNC_SCHEMA.ELEMENTARY_SURFACE'])));

    WR2: NOT (SELF.description = 'machining') OR
    ((verify_required_relating_amr (SELF,
    ['INTEGRATED_CNC_SCHEMA.MACHINING_FEATURE_RELATIONSHIP'])) AND
    (verify_related_type_for_amr (SELF,
    ['INTEGRATED_CNC_SCHEMA.MACHINING_FEATURE_RELATIONSHIP'],

```

```

    ['INTEGRATED_CNC_SCHEMA.MACHINING_FEATURE_PROCESS'])) AND

    (verify_related_type_for_amr (SELF,
    ['INTEGRATED_CNC_SCHEMA.MACHINING_FINAL_FEATURE_RELATIONSHIP'],
    ['INTEGRATED_CNC_SCHEMA.MACHINING_FEATURE_PROCESS'])) AND

    (verify_required_relatng_amr (SELF,
    ['INTEGRATED_CNC_SCHEMA.MACHINING_OPERATION_RELATIONSHIP'])) AND
    (verify_related_type_for_amr (SELF,
    ['INTEGRATED_CNC_SCHEMA.MACHINING_OPERATION_RELATIONSHIP'],
    ['INTEGRATED_CNC_SCHEMA.MACHINING_OPERATION']))
  );

  WR3: NOT (SELF.description = 'turning') OR
  ((2 <= get_count_of_relatng_amr (SELF,
  ['INTEGRATED_CNC_SCHEMA.MACHINING_FEATURE_SEQUENCE_RELATIONSHIP']))
AND
  (verify_related_type_for_amr (SELF,
  ['INTEGRATED_CNC_SCHEMA.MACHINING_FEATURE_SEQUENCE_RELATIONSHIP'],
  ['INTEGRATED_CNC_SCHEMA.MACHINING_FEATURE_PROCESS'])) AND

  (verify_required_relatng_amr (SELF,
  ['INTEGRATED_CNC_SCHEMA.MACHINING_OPERATION_RELATIONSHIP'])) AND
  (verify_related_type_for_amr (SELF,
  ['INTEGRATED_CNC_SCHEMA.MACHINING_OPERATION_RELATIONSHIP'],
  ['INTEGRATED_CNC_SCHEMA.TURNING_TYPE_OPERATION']))
  );

  WR4: NOT (SELF.description IN ['machining', 'turning']) OR
  (verify_optional_in_process_geometry (SELF));

  WR5: ((verify_optional_action_property (SELF, 'toolpath orientation')) AND
  (verify_rep_item_for_action_property (SELF, 'toolpath orientation',
  ['INTEGRATED_CNC_SCHEMA.AXIS2_PLACEMENT_3D'])));

END_ENTITY; -- 10303-238: integrated_cnc_schema

ENTITY machining_workplan
  SUBTYPE OF (machining_process_executable);
  WHERE
  WR1: (1 <= get_count_of_relatng_amr (SELF,
  ['INTEGRATED_CNC_SCHEMA.MACHINING_PROCESS_SEQUENCE_RELATIONSHIP']))
AND
  (verify_related_type_for_amr (SELF,
  ['INTEGRATED_CNC_SCHEMA.MACHINING_PROCESS_SEQUENCE_RELATIONSHIP'],
  ['INTEGRATED_CNC_SCHEMA.MACHINING_PROCESS_EXECUTABLE']));

  WR2: (verify_optional_action_property (SELF, 'channel'));

  WR3: (1 >= SIZEOF (QUERY (act <*
  USEDIN (SELF, 'INTEGRATED_CNC_SCHEMA.ACTION.CHOSEN_METHOD') |
  (act.name = 'setup')))) AND
  (0 = SIZEOF (QUERY (act <*
  USEDIN (SELF, 'INTEGRATED_CNC_SCHEMA.ACTION.CHOSEN_METHOD') |

```

```

        (act.name = 'setup') AND NOT
        ('INTEGRATED_CNC_SCHEMA.PRODUCT_DEFINITION_PROCESS' IN TYPEOF (act))
    ));

WR4: (verify_optional_in_process_geometry (SELF));
END_ENTITY; -- 10303-238: integrated_cnc_schema

ENTITY make_from_usage_option
  SUBTYPE OF (product_definition_usage);
  ranking          : INTEGER;
  ranking_rationale : text;
  quantity         : measure_with_unit;
  WHERE
    WR1: NOT ('NUMBER' IN TYPEOF(quantity.value_component)) OR (quantity.
      value_component > 0);
END_ENTITY; -- 10303-44: product_structure_schema

ENTITY manifold_solid_brep
  SUBTYPE OF (solid_model);
  outer : closed_shell;
END_ENTITY; -- 10303-42: geometric_model_schema

ENTITY manifold_surface_shape_representation
  SUBTYPE OF (shape_representation);
  WHERE
    WR1: SIZEOF(QUERY (it <* SELF.items| NOT (SIZEOF([
      'INTEGRATED_CNC_SCHEMA.SHELL_BASED_SURFACE_MODEL',
      'INTEGRATED_CNC_SCHEMA.MAPPED_ITEM',
      'INTEGRATED_CNC_SCHEMA.AXIS2_PLACEMENT_3D' ] * TYPEOF(it)) =
      1))) = 0;
    WR2: SIZEOF(QUERY (it <* SELF.items| (SIZEOF([
      'INTEGRATED_CNC_SCHEMA.SHELL_BASED_SURFACE_MODEL',
      'INTEGRATED_CNC_SCHEMA.MAPPED_ITEM' ] * TYPEOF(it)) = 1))) >
      0;
    WR3: SIZEOF(QUERY (mi <* QUERY (it <* SELF.items| (
      'INTEGRATED_CNC_SCHEMA.MAPPED_ITEM' IN TYPEOF(it)))| NOT ((
      'INTEGRATED_CNC_SCHEMA.MANIFOLD_SURFACE_SHAPE_REPRESENTATION'
      IN TYPEOF(mi\mapped_item.mapping_source.
      mapped_representation)) AND (SIZEOF(QUERY (mr_it <* mi\
      mapped_item.mapping_source.mapped_representation.items| (
      'INTEGRATED_CNC_SCHEMA.SHELL_BASED_SURFACE_MODEL' IN TYPEOF(
      mr_it)))) > 0)))) = 0;
    WR4: SIZEOF(QUERY (sbsm <* QUERY (it <* SELF.items| (
      'INTEGRATED_CNC_SCHEMA.SHELL_BASED_SURFACE_MODEL' IN TYPEOF(
      it)))| NOT (SIZEOF(QUERY (sh <* sbsm\
      shell_based_surface_model.sbsm_boundary| NOT (SIZEOF([
      'INTEGRATED_CNC_SCHEMA.OPEN_SHELL',
      'INTEGRATED_CNC_SCHEMA.ORIENTED_CLOSED_SHELL',
      'INTEGRATED_CNC_SCHEMA.CLOSED_SHELL' ] * TYPEOF(sh)) = 1))) =
      0))) = 0;
    WR5: SIZEOF(QUERY (sbsm <* QUERY (it <* SELF.items| (
      'INTEGRATED_CNC_SCHEMA.SHELL_BASED_SURFACE_MODEL' IN TYPEOF(
      it)))| NOT (SIZEOF(QUERY (cfs <* sbsm\
      shell_based_surface_model.sbsm_boundary| NOT (SIZEOF(QUERY (

```

```

fa <* cfs\connected_face_set.cfs_faces| NOT (
'INTEGRATED_CNC_SCHEMA.FACE_SURFACE' IN TYPEOF(fa))) = 0))) = 0;
WR6: SIZEOF(QUERY (sbsm <* QUERY (it <* SELF.items| (
'INTEGRATED_CNC_SCHEMA.SHELL_BASED_SURFACE_MODEL' IN TYPEOF(
it)))| NOT (SIZEOF(QUERY (cfs <* sbsm\
shell_based_surface_model.sbsm_boundary| NOT (SIZEOF(QUERY (
fa <* cfs\connected_face_set.cfs_faces| NOT ((
'INTEGRATED_CNC_SCHEMA.ADVANCED_FACE' IN TYPEOF(fa)) OR
msf_surface_check(fa\face_surface.face_geometry)))) = 0))) =
0))) = 0;
WR7: SIZEOF(QUERY (sbsm <* QUERY (it <* SELF.items| (
'INTEGRATED_CNC_SCHEMA.SHELL_BASED_SURFACE_MODEL' IN TYPEOF(
it)))| NOT (SIZEOF(QUERY (cfs <* sbsm\
shell_based_surface_model.sbsm_boundary| NOT (SIZEOF(QUERY (
fa <* cfs\connected_face_set.cfs_faces| NOT ((
'INTEGRATED_CNC_SCHEMA.ADVANCED_FACE' IN TYPEOF(fa)) OR (
SIZEOF(QUERY (bnds <* fa.bounds| NOT (SIZEOF([
'INTEGRATED_CNC_SCHEMA.EDGE_LOOP',
'INTEGRATED_CNC_SCHEMA.VERTEX_LOOP' ] * TYPEOF(bnds.bound)) =
1)))) = 0)))) = 0))) = 0;
WR8: SIZEOF(QUERY (sbsm <* QUERY (it <* SELF.items| (
'INTEGRATED_CNC_SCHEMA.SHELL_BASED_SURFACE_MODEL' IN TYPEOF(
it)))| NOT (SIZEOF(QUERY (cfs <* sbsm\
shell_based_surface_model.sbsm_boundary| NOT (SIZEOF(QUERY (
fa <* cfs\connected_face_set.cfs_faces| NOT ((
'INTEGRATED_CNC_SCHEMA.ADVANCED_FACE' IN TYPEOF(fa)) OR (
SIZEOF(QUERY (elp_fbnds <* QUERY (bnds <* fa.bounds| (
'INTEGRATED_CNC_SCHEMA.EDGE_LOOP' IN TYPEOF(bnds.bound))))|
NOT (SIZEOF(QUERY (oe <* elp_fbnds\path.edge_list| NOT (
'INTEGRATED_CNC_SCHEMA.EDGE_CURVE' IN TYPEOF(oe.edge_element)
))) = 0))) = 0)))) = 0))) = 0;
WR9: SIZEOF(QUERY (sbsm <* QUERY (it <* SELF.items| (
'INTEGRATED_CNC_SCHEMA.SHELL_BASED_SURFACE_MODEL' IN TYPEOF(
it)))| NOT (SIZEOF(QUERY (cfs <* sbsm\
shell_based_surface_model.sbsm_boundary| NOT (SIZEOF(QUERY (
fa <* cfs\connected_face_set.cfs_faces| NOT ((
'INTEGRATED_CNC_SCHEMA.ADVANCED_FACE' IN TYPEOF(fa)) OR (
SIZEOF(QUERY (elp_fbnds <* QUERY (bnds <* fa.bounds| (
'INTEGRATED_CNC_SCHEMA.EDGE_LOOP' IN TYPEOF(bnds.bound))))|
NOT (SIZEOF(QUERY (oe_cv <* QUERY (oe <* elp_fbnds\path.
edge_list| ('INTEGRATED_CNC_SCHEMA.EDGE_CURVE' IN TYPEOF(oe.
edge_element))))| NOT (SIZEOF([
'INTEGRATED_CNC_SCHEMA.B_SPLINE_CURVE',
'INTEGRATED_CNC_SCHEMA.CONIC',
'INTEGRATED_CNC_SCHEMA.CURVE_REPLICA',
'INTEGRATED_CNC_SCHEMA.LINE',
'INTEGRATED_CNC_SCHEMA.OFFSET_CURVE_3D',
'INTEGRATED_CNC_SCHEMA.PCURVE',
'INTEGRATED_CNC_SCHEMA.POLYLINE',
'INTEGRATED_CNC_SCHEMA.SURFACE_CURVE' ] * TYPEOF(oe_cv.
edge_element\edge_curve.edge_geometry)) = 1)))) = 0))) = 0;
WR10: SIZEOF(QUERY (sbsm <* QUERY (it <* SELF.items| (

```

```

        'INTEGRATED_CNC_SCHEMA.SHELL_BASED_SURFACE_MODEL' IN TYPEOF(
it)))| NOT (SIZEOF(QUERY (cfs <* sbsm\
shell_based_surface_model.sbsm_boundary| NOT (SIZEOF(QUERY (
fa <* cfs\connected_face_set.cfs_faces| NOT ((
'INTEGRATED_CNC_SCHEMA.ADVANCED_FACE' IN TYPEOF(fa)) OR (
SIZEOF(QUERY (elp_fbnds <* QUERY (bnds <* fa.bounds| (
'INTEGRATED_CNC_SCHEMA.EDGE_LOOP' IN TYPEOF(bnds.bound))))|
NOT (SIZEOF(QUERY (oe <* elp_fbnds\path.edge_list| NOT
msf_curve_check(oe.edge_element\edge_curve.edge_geometry))) =
0))) = 0))) = 0))) = 0;
WR11: SIZEOF(QUERY (sbsm <* QUERY (it <* SELF.items| (
'INTEGRATED_CNC_SCHEMA.SHELL_BASED_SURFACE_MODEL' IN TYPEOF(
it)))| NOT (SIZEOF(QUERY (cfs <* sbsm\
shell_based_surface_model.sbsm_boundary| NOT (SIZEOF(QUERY (
fa <* cfs\connected_face_set.cfs_faces| NOT ((
'INTEGRATED_CNC_SCHEMA.ADVANCED_FACE' IN TYPEOF(fa)) OR (
SIZEOF(QUERY (elp_fbnds <* QUERY (bnds <* fa.bounds| (
'INTEGRATED_CNC_SCHEMA.EDGE_LOOP' IN TYPEOF(bnds.bound))))|
NOT (SIZEOF(QUERY (oe <* elp_fbnds\path.edge_list| NOT ((
'INTEGRATED_CNC_SCHEMA.VERTEX_POINT' IN TYPEOF(oe.
edge_element.edge_start)) AND (
'INTEGRATED_CNC_SCHEMA.VERTEX_POINT' IN TYPEOF(oe.
edge_element.edge_end)))))) = 0))) = 0))) = 0))) = 0;
WR12: SIZEOF(QUERY (sbsm <* QUERY (it <* SELF.items| (
'INTEGRATED_CNC_SCHEMA.SHELL_BASED_SURFACE_MODEL' IN TYPEOF(
it)))| NOT (SIZEOF(QUERY (cfs <* sbsm\
shell_based_surface_model.sbsm_boundary| NOT (SIZEOF(QUERY (
fa <* cfs\connected_face_set.cfs_faces| NOT ((
'INTEGRATED_CNC_SCHEMA.ADVANCED_FACE' IN TYPEOF(fa)) OR (
SIZEOF(QUERY (elp_fbnds <* QUERY (bnds <* fa.bounds| (
'INTEGRATED_CNC_SCHEMA.EDGE_LOOP' IN TYPEOF(bnds.bound))))|
NOT (SIZEOF(QUERY (oe <* elp_fbnds\path.edge_list| NOT ((
SIZEOF([ 'INTEGRATED_CNC_SCHEMA.CARTESIAN_POINT',
'INTEGRATED_CNC_SCHEMA.DEGENERATE_PCURVE',
'INTEGRATED_CNC_SCHEMA.POINT_ON_CURVE',
'INTEGRATED_CNC_SCHEMA.POINT_ON_SURFACE' ] * TYPEOF(oe.
edge_element.edge_start\vertex_point.vertex_geometry)) = 1)
AND (SIZEOF([ 'INTEGRATED_CNC_SCHEMA.CARTESIAN_POINT',
'INTEGRATED_CNC_SCHEMA.DEGENERATE_PCURVE',
'INTEGRATED_CNC_SCHEMA.POINT_ON_CURVE',
'INTEGRATED_CNC_SCHEMA.POINT_ON_SURFACE' ] * TYPEOF(oe.
edge_element.edge_end\vertex_point.vertex_geometry)) = 1))))
= 0))) = 0))) = 0))) = 0;
WR13: SIZEOF(QUERY (sbsm <* QUERY (it <* SELF.items| (
'INTEGRATED_CNC_SCHEMA.SHELL_BASED_SURFACE_MODEL' IN TYPEOF(
it)))| NOT (SIZEOF(QUERY (cfs <* sbsm\
shell_based_surface_model.sbsm_boundary| NOT (SIZEOF(QUERY (
fa <* cfs\connected_face_set.cfs_faces| NOT ((
'INTEGRATED_CNC_SCHEMA.ADVANCED_FACE' IN TYPEOF(fa)) OR (
SIZEOF(QUERY (vlp_fbnds <* QUERY (bnds <* fa.bounds| (
'INTEGRATED_CNC_SCHEMA.VERTEX_LOOP' IN TYPEOF(bnds.bound))))|
NOT ('INTEGRATED_CNC_SCHEMA.VERTEX_POINT' IN TYPEOF(vlp_fbnds
\vertex_loop.loop_vertex)))) = 0))) = 0))) = 0))) = 0;
WR14: SIZEOF(QUERY (sbsm <* QUERY (it <* SELF.items| (

```



```

'INTEGRATED_CNC_SCHEMA.SHELL_BASED_SURFACE_MODEL' IN TYPEOF(
it)))| NOT (SIZEOF(QUERY (cfs <* sbsm\
shell_based_surface_model.sbsm_boundary| NOT (SIZEOF(QUERY (
fa <* cfs\connected_face_set.cfs_faces| NOT ((
'INTEGRATED_CNC_SCHEMA.ADVANCED_FACE' IN TYPEOF(fa)) OR (
SIZEOF(QUERY (vlp_fbnds <* QUERY (bnds <* fa.bounds| (
'INTEGRATED_CNC_SCHEMA.VERTEX_LOOP' IN TYPEOF(bnds.bound)))|
NOT (SIZEOF([ 'INTEGRATED_CNC_SCHEMA.CARTESIAN_POINT',
'INTEGRATED_CNC_SCHEMA.DEGENERATE_PCURVE',
'INTEGRATED_CNC_SCHEMA.POINT_ON_CURVE',
'INTEGRATED_CNC_SCHEMA.POINT_ON_SURFACE' ] * TYPEOF(vlp_fbnds
\vertex_loop.loop_vertex\vertex_point.vertex_geometry)) = 1))
) = 0))) = 0))) = 0))) = 0;
END_ENTITY; -- 10303-509: aic_manifold_surface

```

```

ENTITY mapped_item
  SUBTYPE OF (representation_item);
  mapping_source : representation_map;
  mapping_target : representation_item;
  WHERE
    WR1: acyclic_mapped_representation(using_representations(SELF), [ SELF
    ]);
END_ENTITY; -- 10303-43: representation_schema

```

```

ENTITY marking
  SUBTYPE OF (feature_definition);
  WHERE
    WR1: SIZEOF(QUERY (pd <* USEDIN(SELF,
      'INTEGRATED_CNC_SCHEMA.PROPERTY_DEFINITION.DEFINITION')| (
      SIZEOF(QUERY (pdr <* USEDIN(pd, 'INTEGRATED_CNC_SCHEMA.' +
      'PROPERTY_DEFINITION_REPRESENTATION.DEFINITION')| (
      'INTEGRATED_CNC_SCHEMA.' +
      'SHAPE_REPRESENTATION_WITH_PARAMETERS' IN TYPEOF(pdr.
      used_representation)) AND ((2 <= SIZEOF(pdr.
      used_representation.items)) AND (SIZEOF(pdr.
      used_representation.items) <= 6)))) = 1))) = 1;
    WR2: SIZEOF(QUERY (pd <* USEDIN(SELF,
      'INTEGRATED_CNC_SCHEMA.PROPERTY_DEFINITION.DEFINITION')| NOT
      (SIZEOF(QUERY (impl_rep <* QUERY (pdr <* USEDIN(pd,
      'INTEGRATED_CNC_SCHEMA.' +
      'PROPERTY_DEFINITION_REPRESENTATION.DEFINITION')| (
      'INTEGRATED_CNC_SCHEMA.' +
      'SHAPE_REPRESENTATION_WITH_PARAMETERS' IN TYPEOF(pdr.
      used_representation)))| NOT (SIZEOF(QUERY (it <* impl_rep.
      used_representation.items| (
      'INTEGRATED_CNC_SCHEMA.DESRIPTIVE_REPRESENTATION_ITEM' IN
      TYPEOF(it)) AND (it.name = 'marking text')) = 1))) = 0))) =
      0;
    WR3: SIZEOF(QUERY (pd <* USEDIN(SELF,
      'INTEGRATED_CNC_SCHEMA.PROPERTY_DEFINITION.DEFINITION')| NOT
      (SIZEOF(QUERY (impl_rep <* QUERY (pdr <* USEDIN(pd,
      'INTEGRATED_CNC_SCHEMA.' +
      'PROPERTY_DEFINITION_REPRESENTATION.DEFINITION')| (
      'INTEGRATED_CNC_SCHEMA.' +

```

```

    'SHAPE_REPRESENTATION_WITH_PARAMETERS' IN TYPEOF(pdr.
used_representation)))| NOT (SIZEOF(QUERY (it <* impl_rep.
used_representation.items| (
    'INTEGRATED_CNC_SCHEMA.DESCRPTIVE_REPRESENTATION_ITEM' IN
    TYPEOF(it)) AND (it.name = 'special instructions')) <= 1)))
= 0))) = 0;
WR4: SIZEOF(QUERY (pd <* USEDIN(SELF,
    'INTEGRATED_CNC_SCHEMA.PROPERTY_DEFINITION.DEFINITION')| NOT
(SIZEOF(QUERY (impl_rep <* QUERY (pdr <* USEDIN(pd,
    'INTEGRATED_CNC_SCHEMA.' +
    'PROPERTY_DEFINITION_REPRESENTATION.DEFINITION')| (
    'INTEGRATED_CNC_SCHEMA.' +
    'SHAPE_REPRESENTATION_WITH_PARAMETERS' IN TYPEOF(pdr.
used_representation)))| NOT (SIZEOF(QUERY (it <* impl_rep.
used_representation.items| (
    'INTEGRATED_CNC_SCHEMA.DESCRPTIVE_REPRESENTATION_ITEM' IN
    TYPEOF(it)) AND (it.name = 'font name')) <= 1)))) = 0))) = 0;
WR5: SIZEOF(QUERY (pd <* USEDIN(SELF,
    'INTEGRATED_CNC_SCHEMA.PROPERTY_DEFINITION.DEFINITION')| NOT
(SIZEOF(QUERY (impl_rep <* QUERY (pdr <* USEDIN(pd,
    'INTEGRATED_CNC_SCHEMA.' +
    'PROPERTY_DEFINITION_REPRESENTATION.DEFINITION')| (
    'INTEGRATED_CNC_SCHEMA.' +
    'SHAPE_REPRESENTATION_WITH_PARAMETERS' IN TYPEOF(pdr.
used_representation)))| NOT (SIZEOF(QUERY (it <* impl_rep.
used_representation.items| (SIZEOF([
    'INTEGRATED_CNC_SCHEMA.MEASURE_REPRESENTATION_ITEM',
    'INTEGRATED_CNC_SCHEMA.LENGTH_MEASURE_WITH_UNIT' ] * TYPEOF(
it)) = 2) AND (it.name = 'character height')) <= 1)))) = 0)))
= 0;
WR6: SIZEOF(QUERY (pd <* USEDIN(SELF,
    'INTEGRATED_CNC_SCHEMA.PROPERTY_DEFINITION.DEFINITION')| NOT
(SIZEOF(QUERY (impl_rep <* QUERY (pdr <* USEDIN(pd,
    'INTEGRATED_CNC_SCHEMA.' +
    'PROPERTY_DEFINITION_REPRESENTATION.DEFINITION')| (
    'INTEGRATED_CNC_SCHEMA.' +
    'SHAPE_REPRESENTATION_WITH_PARAMETERS' IN TYPEOF(pdr.
used_representation)))| NOT (SIZEOF(QUERY (it <* impl_rep.
used_representation.items| (SIZEOF([
    'INTEGRATED_CNC_SCHEMA.MEASURE_REPRESENTATION_ITEM',
    'INTEGRATED_CNC_SCHEMA.LENGTH_MEASURE_WITH_UNIT' ] * TYPEOF(
it)) = 2) AND (it.name = 'character spacing')) <= 1)))) = 0))
) = 0;
WR7: SIZEOF(QUERY (pds <* QUERY (pd <* USEDIN(SELF,
    'INTEGRATED_CNC_SCHEMA.PROPERTY_DEFINITION.DEFINITION')| (
    'INTEGRATED_CNC_SCHEMA.PRODUCT_DEFINITION_SHAPE' IN TYPEOF(pd
)))| NOT (SIZEOF(QUERY (sa_occ <* USEDIN(pds,
    'INTEGRATED_CNC_SCHEMA.SHAPE_ASPECT.OF_SHAPE')| (SIZEOF(QUERY
(sdr <* QUERY (sar <* USEDIN(sa_occ,
    'INTEGRATED_CNC_SCHEMA.SHAPE_ASPECT_RELATIONSHIP.' +
    'RELATED_SHAPE_ASPECT')| (sar.description = 'applied shape')
AND ('INTEGRATED_CNC_SCHEMA.SHAPE_DEFINING_RELATIONSHIP' IN
    TYPEOF(sar)))| ('INTEGRATED_CNC_SCHEMA.SHAPE_ASPECT' IN
    TYPEOF(sdr.relatng_shape_aspect)))) = 1))) = 1))) = 0;

```

```

END_ENTITY; -- 10303-522: aic_machining_feature

ENTITY mass_measure_with_unit
  SUBTYPE OF (measure_with_unit);
  WHERE
    WR1: 'INTEGRATED_CNC_SCHEMA.MASS_UNIT' IN TYPEOF(SELF\measure_with_unit
      .unit_component);
END_ENTITY; -- 10303-41: measure_schema

ENTITY mass_unit
  SUBTYPE OF (named_unit);
  WHERE
    WR1: ((((((SELF\named_unit.dimensions.length_exponent = 0.0) AND (SELF\
      named_unit.dimensions.mass_exponent = 1.0)) AND (SELF\
      named_unit.dimensions.time_exponent = 0.0)) AND (SELF\
      named_unit.dimensions.electric_current_exponent = 0.0)) AND (
      SELF\named_unit.dimensions.thermodynamic_temperature_exponent
      = 0.0)) AND (SELF\named_unit.dimensions.
      amount_of_substance_exponent = 0.0)) AND (SELF\named_unit.
      dimensions.luminous_intensity_exponent = 0.0);
END_ENTITY; -- 10303-41: measure_schema

ENTITY material_designation;
  name      : label;
  definitions : SET [1:?] OF characterized_definition;
END_ENTITY; -- 10303-45: material_property_definition_schema

ENTITY material_designation_characterization;
  name      : label;
  description : text;
  designation : material_designation;
  property   : characterized_material_property;
END_ENTITY; -- 10303-45: material_property_definition_schema

ENTITY material_property
  SUBTYPE OF (property_definition);
  UNIQUE
  UR1: SELF\property_definition.name, SELF\property_definition.definition;
  WHERE
    WR1: ('INTEGRATED_CNC_SCHEMA.CHARACTERIZED_OBJECT' IN TYPEOF(SELF\
      property_definition.definition)) OR (SIZEOF(bag_to_set(USEDIN
      (SELF, 'INTEGRATED_CNC_SCHEMA.' +
      'PROPERTY_DEFINITION_REPRESENTATION.DEFINITION')) - QUERY (
      temp <* bag_to_set(USEDIN(SELF, 'INTEGRATED_CNC_SCHEMA.' +
      'PROPERTY_DEFINITION_REPRESENTATION.DEFINITION')) | (
      'INTEGRATED_CNC_SCHEMA.' + 'MATERIAL_PROPERTY_REPRESENTATION'
      IN TYPEOF(temp)))) = 0);
END_ENTITY; -- 10303-45: material_property_definition_schema

ENTITY material_property_representation
  SUBTYPE OF (property_definition_representation);
  dependent_environment : data_environment;
END_ENTITY; -- 10303-45: material_property_representation_schema

```

ISO 10303-238:2007(E)

```

ENTITY measure_qualification;
    name          : label;
    description    : text;
    qualified_measure : measure_with_unit;
    qualifiers     : SET [1:?] OF value_qualifier;
WHERE
    WR1: SIZEOF(QUERY (temp <* qualifiers| (
        'INTEGRATED_CNC_SCHEMA.PRECISION_QUALIFIER' IN TYPEOF(temp)))
        ) < 2;
END_ENTITY; -- 10303-45: qualified_measure_schema

ENTITY measure_representation_item
    SUBTYPE OF (representation_item, measure_with_unit);
END_ENTITY; -- 10303-45: qualified_measure_schema

ENTITY measure_with_unit
    SUPERTYPE OF (ONEOF(length_measure_with_unit, mass_measure_with_unit,
        time_measure_with_unit, plane_angle_measure_with_unit,
        solid_angle_measure_with_unit, ratio_measure_with_unit));
    value_component : measure_value;
    unit_component  : unit;
WHERE
    WR1: valid_units(SELF);
END_ENTITY; -- 10303-41: measure_schema

ENTITY milling_type_operation
    SUBTYPE OF (machining_operation);
WHERE
    WR1: (verify_optional_action_property      (SELF, 'overcut length')) AND
        (verify_length_measure_action_property (SELF, 'overcut length'));

    WR2: ((verify_optional_relating_amr_with_name (SELF, 'approach',
        ['INTEGRATED_CNC_SCHEMA.MACHINING_STRATEGY_RELATIONSHIP'])) AND
        (verify_related_type_for_amr_with_name (SELF, 'approach',
        ['INTEGRATED_CNC_SCHEMA.MACHINING_STRATEGY_RELATIONSHIP'],
        ['INTEGRATED_CNC_SCHEMA.MACHINING_APPROACH_RETRACT_STRATEGY']))
        );

    WR3: ((verify_optional_relating_amr_with_name (SELF, 'retract',
        ['INTEGRATED_CNC_SCHEMA.MACHINING_STRATEGY_RELATIONSHIP'])) AND
        (verify_related_type_for_amr_with_name (SELF, 'retract',
        ['INTEGRATED_CNC_SCHEMA.MACHINING_STRATEGY_RELATIONSHIP'],
        ['INTEGRATED_CNC_SCHEMA.MACHINING_APPROACH_RETRACT_STRATEGY']))
        );

    WR4: ((verify_optional_relating_amr_with_name (SELF, 'machining',
        ['INTEGRATED_CNC_SCHEMA.MACHINING_STRATEGY_RELATIONSHIP'])) AND
        (verify_related_type_for_amr_with_name (SELF, 'machining',
        ['INTEGRATED_CNC_SCHEMA.MACHINING_STRATEGY_RELATIONSHIP'],
        ['INTEGRATED_CNC_SCHEMA.MILLING_TYPE_STRATEGY']))
        );
END_ENTITY; -- 10303-238: integrated_cnc_schema

ENTITY milling_type_strategy

```

```

SUBTYPE OF (machining_strategy);
WHERE
WR1: NOT (SELF.description IN ['bidirectional', 'bidirectional contour',
    'center milling', 'contour bidirectional', 'contour parallel',
    'contour spiral', 'explicit', 'unidirectional']) OR
    ((verify_optional_action_property      (SELF, 'overlap ratio')) AND
    (verify_ratio_measure_action_property  (SELF, 'overlap ratio')) AND

    (verify_optional_action_property      (SELF, 'multiple passes')) AND
    (verify_enumeration_action_property   (SELF, 'multiple passes',
    ['multiple passes allowed', 'multiple passes not allowed'])) );

WR2: NOT (SELF.description = 'bidirectional') OR
    ((verify_optional_action_property      (SELF, 'feed direction')) AND
    (verify_rep_item_for_action_property   (SELF, 'feed direction',
    ['INTEGRATED_CNC_SCHEMA.DIRECTION'])) AND

    (verify_optional_action_property      (SELF, 'stepover direction')) AND
    (verify_enumeration_action_property   (SELF, 'stepover direction',
    ['left', 'right'])) AND

    (verify_optional_action_property      (SELF, 'connection strategy'))

AND

    (verify_enumeration_action_property   (SELF, 'connection strategy',
    ['straight line', 'lift shift plunge', 'degouge', 'loop back'])) );

WR3: NOT (SELF.description IN ['bidirectional contour',
    'contour bidirectional']) OR
    ((verify_optional_action_property      (SELF, 'feed direction')) AND
    (verify_rep_item_for_action_property   (SELF, 'feed direction',
    ['INTEGRATED_CNC_SCHEMA.DIRECTION'])) AND

    (verify_optional_action_property      (SELF, 'stepover direction')) AND
    (verify_enumeration_action_property   (SELF, 'stepover direction',
    ['left', 'right'])) AND

    (verify_optional_action_property      (SELF, 'rotation direction')) AND
    (verify_enumeration_action_property   (SELF, 'rotation direction',
    ['clockwise', 'counterclockwise'])) AND

    (verify_optional_action_property      (SELF, 'spiral cutmode')) AND
    (verify_enumeration_action_property   (SELF, 'spiral cutmode',
    ['climb', 'conventional'])) );

WR4: NOT (SELF.description IN ['contour parallel', 'contour spiral']) OR
    ((verify_optional_action_property      (SELF, 'rotation direction')) AND
    (verify_enumeration_action_property   (SELF, 'rotation direction',
    ['clockwise', 'counterclockwise'])) AND

    (verify_optional_action_property      (SELF, 'cutmode')) AND
    (verify_enumeration_action_property   (SELF, 'cutmode',
    ['climb', 'conventional'])) );

WR5: NOT (SELF.description = 'unidirectional') OR

```

```

        ((verify_optional_action_property      (SELF, 'feed direction')) AND
         (verify_rep_item_for_action_property  (SELF, 'feed direction',
         ['INTEGRATED_CNC_SCHEMA.DIRECTION'])) AND

         (verify_optional_action_property      (SELF, 'cutmode')) AND
         (verify_enumeration_action_property  (SELF, 'cutmode',
         ['climb', 'conventional']))) );
END_ENTITY; -- 10303-238: integrated_cnc_schema

ENTITY modified_geometric_tolerance
  SUBTYPE OF (geometric_tolerance);
  modifier : limit_condition;
END_ENTITY; -- 10303-47: shape_tolerance_schema

ENTITY modified_pattern
  SUBTYPE OF (shape_aspect);
  WHERE
    WR1: SIZEOF(QUERY (fcr <* QUERY (sar <* USEDIN(SELF,
      'INTEGRATED_CNC_SCHEMA.SHAPE_ASPECT_RELATIONSHIP.' +
      'RELATING_SHAPE_ASPECT') | (
      'INTEGRATED_CNC_SCHEMA.FEATURE_COMPONENT_RELATIONSHIP' IN
      TYPEOF(sar))) | (SIZEOF([
      'INTEGRATED_CNC_SCHEMA.REPLICATE_FEATURE',
      'INTEGRATED_CNC_SCHEMA.INSTANCED_FEATURE' ] * TYPEOF(fcr.
      related_shape_aspect.of_shape.definition)) >= 1) AND (fcr.
      description = 'base shape')) = 1;
    WR2: SIZEOF(QUERY (fcr <* QUERY (sar <* USEDIN(SELF,
      'INTEGRATED_CNC_SCHEMA.SHAPE_ASPECT_RELATIONSHIP.' +
      'RELATING_SHAPE_ASPECT') | (
      'INTEGRATED_CNC_SCHEMA.FEATURE_COMPONENT_RELATIONSHIP' IN
      TYPEOF(sar))) | (SIZEOF([
      'INTEGRATED_CNC_SCHEMA.CIRCULAR_PATTERN',
      'INTEGRATED_CNC_SCHEMA.RECTANGULAR_PATTERN' ] * TYPEOF(fcr.
      related_shape_aspect.of_shape.definition)) = 1) AND (fcr.
      description = 'base pattern')) = 1;
    WR3: SIZEOF(QUERY (sar <* USEDIN(SELF,
      'INTEGRATED_CNC_SCHEMA.SHAPE_ASPECT_RELATIONSHIP.' +
      'RELATING_SHAPE_ASPECT') | (SIZEOF(QUERY (msar <* USEDIN(sar.
      related_shape_aspect,
      'INTEGRATED_CNC_SCHEMA.SHAPE_ASPECT_RELATIONSHIP.' +
      'RELATED_SHAPE_ASPECT') | ((SIZEOF([
      'INTEGRATED_CNC_SCHEMA.PATTERN_OFFSET_MEMBERSHIP',
      'INTEGRATED_CNC_SCHEMA.PATTERN_OMIT_MEMBERSHIP' ] * TYPEOF(
      sar)) = 1) AND (sar.description = 'modified pattern')) AND (
      sar :<>: msar))) >= 1))) = 0;
END_ENTITY; -- 10303-522: aic_machining_feature

ENTITY multiple_arity_boolean_expression
  ABSTRACT SUPERTYPE OF (ONEOF(and_expression, or_expression))
  SUBTYPE OF (boolean_expression, multiple_arity_generic_expression);
  SELF\multiple_arity_generic_expression.operands : LIST [2:?] OF
    boolean_expression;
END_ENTITY; -- 13584-20: iso13584_expressions_schema

```

```

ENTITY multiple_arity_generic_expression
  ABSTRACT SUPERTYPE
  SUBTYPE OF (generic_expression);
  operands : LIST [2:?] OF generic_expression;
END_ENTITY; -- 13584-20: iso13584_generic_expressions_schema

ENTITY name_attribute;
  attribute_value : label;
  named_item      : name_attribute_select;
END_ENTITY; -- 10303-41: basic_attribute_schema

ENTITY named_unit
  SUPERTYPE OF (ONEOF(si_unit, conversion_based_unit,
    context_dependent_unit) ANDOR ONEOF(length_unit, mass_unit, time_unit,
    plane_angle_unit, solid_angle_unit, ratio_unit));
  dimensions : dimensional_exponents;
END_ENTITY; -- 10303-41: measure_schema

ENTITY next_assembly_usage_occurrence
  SUBTYPE OF (assembly_component_usage);
END_ENTITY; -- 10303-44: product_structure_schema

ENTITY ngon_closed_profile
  SUBTYPE OF (shape_aspect);
  WHERE
    WR1: 'INTEGRATED_CNC_SCHEMA.FEATURE_COMPONENT_DEFINITION' IN TYPEOF(
      SELF.of_shape.definition);
    WR2: SIZEOF(QUERY (pd <* USEDIN(SELF,
      'INTEGRATED_CNC_SCHEMA.PROPERTY_DEFINITION.DEFINITION') | NOT
      (SIZEOF(QUERY (pdr <* USEDIN(pd, 'INTEGRATED_CNC_SCHEMA.' +
      'PROPERTY_DEFINITION_REPRESENTATION.DEFINITION') | (
      'INTEGRATED_CNC_SCHEMA.' +
      'SHAPE_REPRESENTATION_WITH_PARAMETERS' IN TYPEOF(pdr.
      used_representation)))) = 1))) = 0;
    WR3: SIZEOF(QUERY (pd <* USEDIN(SELF,
      'INTEGRATED_CNC_SCHEMA.PROPERTY_DEFINITION.DEFINITION') | NOT
      (SIZEOF(QUERY (impl_rep <* QUERY (pdr <* USEDIN(pd,
      'INTEGRATED_CNC_SCHEMA.' +
      'PROPERTY_DEFINITION_REPRESENTATION.DEFINITION') | (
      'INTEGRATED_CNC_SCHEMA.' +
      'SHAPE_REPRESENTATION_WITH_PARAMETERS' IN TYPEOF(pdr.
      used_representation))) | NOT ((SIZEOF(impl_rep.
      used_representation.items) >= 3) AND (SIZEOF(impl_rep.
      used_representation.items) <= 4)))) = 0))) = 0;
    WR4: SIZEOF(QUERY (pd <* USEDIN(SELF,
      'INTEGRATED_CNC_SCHEMA.PROPERTY_DEFINITION.DEFINITION') | (
      SIZEOF(QUERY (pdr <* USEDIN(pd, 'INTEGRATED_CNC_SCHEMA.' +
      'PROPERTY_DEFINITION_REPRESENTATION.DEFINITION') | (
      'INTEGRATED_CNC_SCHEMA.' +
      'SHAPE_REPRESENTATION_WITH_PARAMETERS' IN TYPEOF(pdr.
      used_representation)) AND (SIZEOF(QUERY (srwp_i <* pdr.
      used_representation.items | (((srwp_i.name = 'orientation')
      OR (srwp_i.name = 'number of sides')) OR (srwp_i.name =
      'circumscribed diameter')) OR (srwp_i.name = 'corner radius'))

```

```

) OR (srwp_i.name = 'diameter across flats')) = SIZEOF(pdr.
used_representation.items))) = 1))) = 1;
WR5: SIZEOF(QUERY (pd <* USEDIN(SELF,
'INTEGRATED_CNC_SCHEMA.PROPERTY_DEFINITION.DEFINITION')| NOT
(SIZEOF(QUERY (impl_rep <* QUERY (pdr <* USEDIN(pd,
'INTEGRATED_CNC_SCHEMA.' +
'PROPERTY_DEFINITION_REPRESENTATION.DEFINITION')| (
'INTEGRATED_CNC_SCHEMA.' +
'SHAPE_REPRESENTATION_WITH_PARAMETERS' IN TYPEOF(pdr.
used_representation)))| NOT (SIZEOF(QUERY (it <* impl_rep.
used_representation.items| ('INTEGRATED_CNC_SCHEMA.PLACEMENT'
IN TYPEOF(it)) AND (it.name = 'orientation')) = 1))) = 0)))
= 0;
WR6: SIZEOF(QUERY (pd <* USEDIN(SELF,
'INTEGRATED_CNC_SCHEMA.PROPERTY_DEFINITION.DEFINITION')| NOT
(SIZEOF(QUERY (impl_rep <* QUERY (pdr <* USEDIN(pd,
'INTEGRATED_CNC_SCHEMA.' +
'PROPERTY_DEFINITION_REPRESENTATION.DEFINITION')| (
'INTEGRATED_CNC_SCHEMA.' +
'SHAPE_REPRESENTATION_WITH_PARAMETERS' IN TYPEOF(pdr.
used_representation)))| NOT (SIZEOF(QUERY (it <* impl_rep.
used_representation.items| ((
'INTEGRATED_CNC_SCHEMA.MEASURE_REPRESENTATION_ITEM' IN TYPEOF
(it)) AND ('INTEGRATED_CNC_SCHEMA.COUNT_MEASURE' IN TYPEOF(it
\measure_with_unit.value_component))) AND (it.name =
'number of sides')) = 1))) = 0))) = 0;
WR7: SIZEOF(QUERY (pd <* USEDIN(SELF,
'INTEGRATED_CNC_SCHEMA.PROPERTY_DEFINITION.DEFINITION')| NOT
(SIZEOF(QUERY (impl_rep <* QUERY (pdr <* USEDIN(pd,
'INTEGRATED_CNC_SCHEMA.' +
'PROPERTY_DEFINITION_REPRESENTATION.DEFINITION')| (
'INTEGRATED_CNC_SCHEMA.' +
'SHAPE_REPRESENTATION_WITH_PARAMETERS' IN TYPEOF(pdr.
used_representation)))| NOT (SIZEOF(QUERY (it <* impl_rep.
used_representation.items| (SIZEOF([
'INTEGRATED_CNC_SCHEMA.MEASURE_REPRESENTATION_ITEM',
'INTEGRATED_CNC_SCHEMA.LENGTH_MEASURE_WITH_UNIT' ] * TYPEOF(
it)) = 2) AND (it.name IN [ 'circumscribed diameter',
'diameter across flats' ]))) = 1))) = 0))) = 0;
WR8: SIZEOF(QUERY (pd <* USEDIN(SELF,
'INTEGRATED_CNC_SCHEMA.PROPERTY_DEFINITION.DEFINITION')| NOT
(SIZEOF(QUERY (impl_rep <* QUERY (pdr <* USEDIN(pd,
'INTEGRATED_CNC_SCHEMA.' +
'PROPERTY_DEFINITION_REPRESENTATION.DEFINITION')| (
'INTEGRATED_CNC_SCHEMA.' +
'SHAPE_REPRESENTATION_WITH_PARAMETERS' IN TYPEOF(pdr.
used_representation)))| NOT (SIZEOF(QUERY (it <* impl_rep.
used_representation.items| (SIZEOF([
'INTEGRATED_CNC_SCHEMA.MEASURE_REPRESENTATION_ITEM',
'INTEGRATED_CNC_SCHEMA.LENGTH_MEASURE_WITH_UNIT' ] * TYPEOF(
it)) = 2) AND (it.name = 'corner radius')) <= 1))) = 0))) =
0;
END_ENTITY; -- 10303-522: aic_machining_feature

```



```

ENTITY ngon_shape_representation
  SUBTYPE OF (shape_representation_with_parameters);
  WHERE
    WR1: SIZEOF(SELF.items) = 5;
    WR2: SIZEOF(QUERY (it <* SELF.items| ('INTEGRATED_CNC_SCHEMA.PLACEMENT'
      IN TYPEOF(it)) AND (it.name = 'orientation')) = 1;
    WR3: SIZEOF(QUERY (it <* SELF.items| (SIZEOF([
      'INTEGRATED_CNC_SCHEMA.MEASURE_REPRESENTATION_ITEM',
      'INTEGRATED_CNC_SCHEMA.LENGTH_MEASURE_WITH_UNIT' ] * TYPEOF(
      it)) = 2) AND (it.name = 'length')) = 1;
    WR4: SIZEOF(QUERY (it <* SELF.items| (SIZEOF([
      'INTEGRATED_CNC_SCHEMA.MEASURE_REPRESENTATION_ITEM',
      'INTEGRATED_CNC_SCHEMA.LENGTH_MEASURE_WITH_UNIT' ] * TYPEOF(
      it)) = 2) AND (it.name = 'corner radius')) = 1;
    WR5: SIZEOF(QUERY (it <* SELF.items| (SIZEOF([
      'INTEGRATED_CNC_SCHEMA.MEASURE_REPRESENTATION_ITEM',
      'INTEGRATED_CNC_SCHEMA.LENGTH_MEASURE_WITH_UNIT' ] * TYPEOF(
      it)) = 2) AND (it.name IN [ 'circumscribed diameter',
      'diameter across flats' ]))) = 1;
    WR6: SIZEOF(QUERY (it <* SELF.items| ((
      'INTEGRATED_CNC_SCHEMA.MEASURE_REPRESENTATION_ITEM' IN TYPEOF(
      it)) AND ('INTEGRATED_CNC_SCHEMA.COUNT_MEASURE' IN TYPEOF(it
      \measure_with_unit.value_component))) AND (it.name =
      'number of sides')) = 1;
END_ENTITY; -- 10303-238: integrated_cnc_schema

```

```

ENTITY non_manifold_surface_shape_representation
  SUBTYPE OF (shape_representation);
  WHERE
    WR1: SIZEOF(QUERY (it <* SELF.items| NOT (SIZEOF([
      'INTEGRATED_CNC_SCHEMA.FACE_BASED_SURFACE_MODEL',
      'INTEGRATED_CNC_SCHEMA.MAPPED_ITEM',
      'INTEGRATED_CNC_SCHEMA.AXIS2_PLACEMENT_3D' ] * TYPEOF(it)) =
      1))) = 0;
    WR2: SIZEOF(QUERY (it <* SELF.items| (SIZEOF([
      'INTEGRATED_CNC_SCHEMA.FACE_BASED_SURFACE_MODEL',
      'INTEGRATED_CNC_SCHEMA.MAPPED_ITEM' ] * TYPEOF(it)) = 1))) >
      0;
    WR3: SIZEOF(QUERY (mi <* QUERY (it <* SELF.items| (
      'INTEGRATED_CNC_SCHEMA.MAPPED_ITEM' IN TYPEOF(it)))| NOT ((
      'INTEGRATED_CNC_SCHEMA.' +
      'NON_MANIFOLD_SURFACE_SHAPE_REPRESENTATION' IN TYPEOF(mi\
      mapped_item.mapping_source.mapped_representation)) AND (
      SIZEOF(QUERY (mr_it <* mi\mapped_item.mapping_source.
      mapped_representation.items| (
      'INTEGRATED_CNC_SCHEMA.FACE_BASED_SURFACE_MODEL' IN TYPEOF(
      mr_it)))) > 0)))) = 0;
    WR4: SIZEOF(QUERY (fbsm <* QUERY (it <* SELF.items| (
      'INTEGRATED_CNC_SCHEMA.FACE_BASED_SURFACE_MODEL' IN TYPEOF(it
      )))| NOT (SIZEOF(QUERY (cfs <* fbsm\face_based_surface_model.
      fbsm_faces| NOT (SIZEOF(QUERY (fa <* cfs.cfs_faces| NOT (
      SIZEOF([ 'INTEGRATED_CNC_SCHEMA.FACE_SURFACE',
      'INTEGRATED_CNC_SCHEMA.ORIENTED_FACE' ] * TYPEOF(fa)) = 1)))
      = 0))) = 0))) = 0;

```

```

WR5: SIZEOF(QUERY (fbsm <* QUERY (it <* SELF.items| (
  'INTEGRATED_CNC_SCHEMA.FACE_BASED_SURFACE_MODEL' IN TYPEOF(it
)))| NOT (SIZEOF(QUERY (cfs <* fbsm\face_based_surface_model.
fbsm_faces| NOT (SIZEOF(QUERY (f_sf <* QUERY (fa <* cfs.
cfs_faces| ('INTEGRATED_CNC_SCHEMA.FACE_SURFACE' IN TYPEOF(fa
)))| NOT (('INTEGRATED_CNC_SCHEMA.ADVANCED_FACE' IN TYPEOF(
f_sf)) OR nmsf_surface_check(f_sf\face_surface.face_geometry)
))) = 0))) = 0);

WR6: SIZEOF(QUERY (fbsm <* QUERY (it <* SELF.items| (
  'INTEGRATED_CNC_SCHEMA.FACE_BASED_SURFACE_MODEL' IN TYPEOF(it
)))| NOT (SIZEOF(QUERY (cfs <* fbsm\face_based_surface_model.
fbsm_faces| NOT (SIZEOF(QUERY (o_fa <* QUERY (fa <* cfs.
cfs_faces| ('INTEGRATED_CNC_SCHEMA.ORIENTED_FACE' IN TYPEOF(
fa)))| NOT (('INTEGRATED_CNC_SCHEMA.ADVANCED_FACE' IN TYPEOF(
o_fa\oriented_face.face_element)) OR nmsf_surface_check(o_fa\
oriented_face.face_element\face_surface.face_geometry)))) = 0
))) = 0))) = 0);

WR7: SIZEOF(QUERY (fbsm <* QUERY (it <* SELF.items| (
  'INTEGRATED_CNC_SCHEMA.FACE_BASED_SURFACE_MODEL' IN TYPEOF(it
)))| NOT (SIZEOF(QUERY (cfs <* fbsm\face_based_surface_model.
fbsm_faces| NOT (SIZEOF(QUERY (fa <* cfs.cfs_faces| NOT ((
  'INTEGRATED_CNC_SCHEMA.ADVANCED_FACE' IN TYPEOF(fa)) OR (
  SIZEOF(QUERY (bnds <* fa.bounds| NOT (SIZEOF([
  'INTEGRATED_CNC_SCHEMA.EDGE_LOOP',
  'INTEGRATED_CNC_SCHEMA.VERTEX_LOOP' ] * TYPEOF(bnds.bound)) =
  1))) = 0)))) = 0))) = 0))) = 0);

WR8: SIZEOF(QUERY (fbsm <* QUERY (it <* SELF.items| (
  'INTEGRATED_CNC_SCHEMA.FACE_BASED_SURFACE_MODEL' IN TYPEOF(it
)))| NOT (SIZEOF(QUERY (cfs <* fbsm\face_based_surface_model.
fbsm_faces| NOT (SIZEOF(QUERY (fa <* cfs.cfs_faces| NOT ((
  'INTEGRATED_CNC_SCHEMA.ADVANCED_FACE' IN TYPEOF(fa)) OR (
  SIZEOF(QUERY (elp_fbnds <* QUERY (bnds <* fa.bounds| (
  'INTEGRATED_CNC_SCHEMA.EDGE_LOOP' IN TYPEOF(bnds.bound)))|
  NOT (SIZEOF(QUERY (oe <* elp_fbnds\path.edge_list| NOT (
  'INTEGRATED_CNC_SCHEMA.EDGE_CURVE' IN TYPEOF(oe.edge_element)
  ))) = 0))) = 0)))) = 0))) = 0))) = 0);

WR9: SIZEOF(QUERY (fbsm <* QUERY (it <* SELF.items| (
  'INTEGRATED_CNC_SCHEMA.FACE_BASED_SURFACE_MODEL' IN TYPEOF(it
)))| NOT (SIZEOF(QUERY (cfs <* fbsm\face_based_surface_model.
fbsm_faces| NOT (SIZEOF(QUERY (fa <* cfs.cfs_faces| NOT ((
  'INTEGRATED_CNC_SCHEMA.ADVANCED_FACE' IN TYPEOF(fa)) OR (
  SIZEOF(QUERY (elp_fbnds <* QUERY (bnds <* fa.bounds| (
  'INTEGRATED_CNC_SCHEMA.EDGE_LOOP' IN TYPEOF(bnds.bound)))|
  NOT (SIZEOF(QUERY (oe_cv <* QUERY (oe <* elp_fbnds\path.
  edge_list| ('INTEGRATED_CNC_SCHEMA.EDGE_CURVE' IN TYPEOF(oe.
  edge_element)))| NOT (SIZEOF([
  'INTEGRATED_CNC_SCHEMA.B_SPLINE_CURVE',
  'INTEGRATED_CNC_SCHEMA.CONIC',
  'INTEGRATED_CNC_SCHEMA.CURVE_REPLICA',
  'INTEGRATED_CNC_SCHEMA.LINE',
  'INTEGRATED_CNC_SCHEMA.OFFSET_CURVE_3D',
  'INTEGRATED_CNC_SCHEMA.PCURVE',
  'INTEGRATED_CNC_SCHEMA.POLYLINE',
  'INTEGRATED_CNC_SCHEMA.SURFACE_CURVE' ] * TYPEOF(oe_cv.

```

```

edge_element\edge_curve.edge_geometry)) = 1))) = 0))) = 0))) = 0))) = 0;
WR10: SIZEOF(QUERY (fbsm <* QUERY (it <* SELF.items| (
  'INTEGRATED_CNC_SCHEMA.FACE_BASED_SURFACE_MODEL' IN TYPEOF(it
)))| NOT (SIZEOF(QUERY (cfs <* fbsm\face_based_surface_model.
fbsm_faces| NOT (SIZEOF(QUERY (fa <* cfs.cfs_faces| NOT ((
  'INTEGRATED_CNC_SCHEMA.ADVANCED_FACE' IN TYPEOF(fa)) OR (
  SIZEOF(QUERY (elp_fbnds <* QUERY (bnds <* fa.bounds| (
  'INTEGRATED_CNC_SCHEMA.EDGE_LOOP' IN TYPEOF(bnds.bound))))|
  NOT (SIZEOF(QUERY (oe <* elp_fbnds\path.edge_list| NOT
  nmsf_curve_check(oe.edge_element\edge_curve.edge_geometry)))
  = 0))) = 0))) = 0))) = 0))) = 0;
WR11: SIZEOF(QUERY (fbsm <* QUERY (it <* SELF.items| (
  'INTEGRATED_CNC_SCHEMA.FACE_BASED_SURFACE_MODEL' IN TYPEOF(it
)))| NOT (SIZEOF(QUERY (cfs <* fbsm\face_based_surface_model.
fbsm_faces| NOT (SIZEOF(QUERY (fa <* cfs.cfs_faces| NOT ((
  'INTEGRATED_CNC_SCHEMA.ADVANCED_FACE' IN TYPEOF(fa)) OR (
  SIZEOF(QUERY (elp_fbnds <* QUERY (bnds <* fa.bounds| (
  'INTEGRATED_CNC_SCHEMA.EDGE_LOOP' IN TYPEOF(bnds.bound))))|
  NOT (SIZEOF(QUERY (oe <* elp_fbnds\path.edge_list| NOT ((
  'INTEGRATED_CNC_SCHEMA.VERTEX_POINT' IN TYPEOF(oe.
edge_element.edge_start)) AND (
  'INTEGRATED_CNC_SCHEMA.VERTEX_POINT' IN TYPEOF(oe.
edge_element.edge_end)))))) = 0))) = 0))) = 0))) = 0))) = 0;
WR12: SIZEOF(QUERY (fbsm <* QUERY (it <* SELF.items| (
  'INTEGRATED_CNC_SCHEMA.FACE_BASED_SURFACE_MODEL' IN TYPEOF(it
)))| NOT (SIZEOF(QUERY (cfs <* fbsm\face_based_surface_model.
fbsm_faces| NOT (SIZEOF(QUERY (fa <* cfs.cfs_faces| NOT ((
  'INTEGRATED_CNC_SCHEMA.ADVANCED_FACE' IN TYPEOF(fa)) OR (
  SIZEOF(QUERY (elp_fbnds <* QUERY (bnds <* fa.bounds| (
  'INTEGRATED_CNC_SCHEMA.EDGE_LOOP' IN TYPEOF(bnds.bound))))|
  NOT (SIZEOF(QUERY (oe <* elp_fbnds\path.edge_list| NOT ((
  SIZEOF([ 'INTEGRATED_CNC_SCHEMA.CARTESIAN_POINT',
  'INTEGRATED_CNC_SCHEMA.DEGENERATE_PCURVE',
  'INTEGRATED_CNC_SCHEMA.POINT_ON_CURVE',
  'INTEGRATED_CNC_SCHEMA.POINT_ON_SURFACE' ] * TYPEOF(oe.
edge_element.edge_start\vertex_point.vertex_geometry)) = 1)
  AND (SIZEOF([ 'INTEGRATED_CNC_SCHEMA.CARTESIAN_POINT',
  'INTEGRATED_CNC_SCHEMA.DEGENERATE_PCURVE',
  'INTEGRATED_CNC_SCHEMA.POINT_ON_CURVE',
  'INTEGRATED_CNC_SCHEMA.POINT_ON_SURFACE' ] * TYPEOF(oe.
edge_element.edge_end\vertex_point.vertex_geometry)) = 1))))
  = 0))) = 0))) = 0))) = 0))) = 0;
WR13: SIZEOF(QUERY (fbsm <* QUERY (it <* SELF.items| (
  'INTEGRATED_CNC_SCHEMA.FACE_BASED_SURFACE_MODEL' IN TYPEOF(it
)))| NOT (SIZEOF(QUERY (cfs <* fbsm\face_based_surface_model.
fbsm_faces| NOT (SIZEOF(QUERY (fa <* cfs.cfs_faces| NOT ((
  'INTEGRATED_CNC_SCHEMA.ADVANCED_FACE' IN TYPEOF(fa)) OR (
  SIZEOF(QUERY (vlp_fbnds <* QUERY (bnds <* fa.bounds| (
  'INTEGRATED_CNC_SCHEMA.VERTEX_LOOP' IN TYPEOF(bnds.bound))))|
  NOT ('INTEGRATED_CNC_SCHEMA.VERTEX_POINT' IN TYPEOF(vlp_fbnds
\vertex_loop.loop_vertex)))) = 0))) = 0))) = 0))) = 0;
WR14: SIZEOF(QUERY (fbsm <* QUERY (it <* SELF.items| (
  'INTEGRATED_CNC_SCHEMA.FACE_BASED_SURFACE_MODEL' IN TYPEOF(it

```

```

    )))| NOT (SIZEOF(QUERY (cfs <* fbsm\face_based_surface_model.
    fbsm_faces| NOT (SIZEOF(QUERY (fa <* cfs.cfs_faces| NOT ((
    'INTEGRATED_CNC_SCHEMA.ADVANCED_FACE' IN TYPEOF(fa)) OR (
    SIZEOF(QUERY (vlp_fbnds <* QUERY (bnds <* fa.bounds| (
    'INTEGRATED_CNC_SCHEMA.VERTEX_LOOP' IN TYPEOF(bnds.bound)))|
    NOT (SIZEOF([ 'INTEGRATED_CNC_SCHEMA.CARTESIAN_POINT',
    'INTEGRATED_CNC_SCHEMA.DEGENERATE_PCURVE',
    'INTEGRATED_CNC_SCHEMA.POINT_ON_CURVE',
    'INTEGRATED_CNC_SCHEMA.POINT_ON_SURFACE' ] * TYPEOF(vlp_fbnds
    \vertex_loop.loop_vertex\vertex_point.vertex_geometry)) = 1))
    ) = 0))) = 0))) = 0))) = 0;
END_ENTITY; -- 10303-508: aic_non_manifold_surface

```

```

ENTITY not_expression
  SUBTYPE OF (unary_boolean_expression);
  SELF\unary_generic_expression.operand : boolean_expression;
END_ENTITY; -- 13584-20: iso13584_expressions_schema

```

```

ENTITY numeric_expression
  ABSTRACT SUPERTYPE OF (ONEOF(simple_numeric_expression))
  SUBTYPE OF (expression);
  DERIVE
    is_int      : BOOLEAN := is_int_expr(SELF);
    sql_mappable : BOOLEAN := is_SQL_mappable(SELF);
END_ENTITY; -- 13584-20: iso13584_expressions_schema

```

```

ENTITY numeric_variable
  SUPERTYPE OF (ONEOF(int_numeric_variable, real_numeric_variable))
  SUBTYPE OF (simple_numeric_expression, variable);
  WHERE
    WR1: ('INTEGRATED_CNC_SCHEMA.INT_NUMERIC_VARIABLE' IN TYPEOF(SELF)) OR
        ('INTEGRATED_CNC_SCHEMA.REAL_NUMERIC_VARIABLE' IN TYPEOF(SELF
        ));
END_ENTITY; -- 13584-20: iso13584_expressions_schema

```

```

ENTITY object_role;
  name      : label;
  description : OPTIONAL text;
END_ENTITY; -- 10303-41: basic_attribute_schema

```

```

ENTITY offset_curve_3d
  SUBTYPE OF (curve);
  basis_curve      : curve;
  distance         : length_measure;
  self_intersect  : LOGICAL;
  ref_direction   : direction;
  WHERE
    WR1: (basis_curve.dim = 3) AND (ref_direction.dim = 3);
END_ENTITY; -- 10303-42: geometry_schema

```

```

ENTITY offset_surface
  SUBTYPE OF (surface);
  basis_surface   : surface;
  distance       : length_measure;

```

```

    self_intersect : LOGICAL;
END_ENTITY; -- 10303-42: geometry_schema

ENTITY open_path_profile
  SUBTYPE OF (shape_aspect);
  WHERE
    WR1: 'INTEGRATED_CNC_SCHEMA.FEATURE_COMPONENT_DEFINITION' IN TYPEOF(
      SELF.of_shape.definition);
    WR2: SIZEOF(QUERY (pd <* USEDIN(SELF,
      'INTEGRATED_CNC_SCHEMA.PROPERTY_DEFINITION.DEFINITION') | NOT
      (SIZEOF(QUERY (pdr <* USEDIN(pd, 'INTEGRATED_CNC_SCHEMA.' +
      'PROPERTY_DEFINITION_REPRESENTATION.DEFINITION') | (
      'INTEGRATED_CNC_SCHEMA.' +
      'SHAPE_REPRESENTATION_WITH_PARAMETERS' IN TYPEOF(pdr.
      used_representation)))) = 1))) = 0;
    WR3: SIZEOF(QUERY (pd <* USEDIN(SELF,
      'INTEGRATED_CNC_SCHEMA.PROPERTY_DEFINITION.DEFINITION') | NOT
      (SIZEOF(QUERY (impl_rep <* QUERY (pdr <* USEDIN(pd,
      'INTEGRATED_CNC_SCHEMA.' +
      'PROPERTY_DEFINITION_REPRESENTATION.DEFINITION') | (
      'INTEGRATED_CNC_SCHEMA.' +
      'SHAPE_REPRESENTATION_WITH_PARAMETERS' IN TYPEOF(pdr.
      used_representation))) | NOT (SIZEOF(impl_rep.
      used_representation.items) = 1))) = 0))) = 0;
    WR4: SIZEOF(QUERY (pd <* USEDIN(SELF,
      'INTEGRATED_CNC_SCHEMA.PROPERTY_DEFINITION.DEFINITION') | NOT
      (SIZEOF(QUERY (impl_rep <* QUERY (pdr <* USEDIN(pd,
      'INTEGRATED_CNC_SCHEMA.' +
      'PROPERTY_DEFINITION_REPRESENTATION.DEFINITION') | (
      'INTEGRATED_CNC_SCHEMA.' +
      'SHAPE_REPRESENTATION_WITH_PARAMETERS' IN TYPEOF(pdr.
      used_representation))) | NOT (SIZEOF(QUERY (it <* impl_rep.
      used_representation.items | ('INTEGRATED_CNC_SCHEMA.PLACEMENT'
      IN TYPEOF(it)) AND (it.name = 'orientation')) = 1))) = 0)))
      = 0;
    WR5: SIZEOF(QUERY (pd <* USEDIN(SELF,
      'INTEGRATED_CNC_SCHEMA.PROPERTY_DEFINITION.DEFINITION') | NOT
      (SIZEOF(QUERY (pdr <* USEDIN(pd, 'INTEGRATED_CNC_SCHEMA.' +
      'PROPERTY_DEFINITION_REPRESENTATION.DEFINITION') | (
      'INTEGRATED_CNC_SCHEMA.PATH_SHAPE_REPRESENTATION' IN TYPEOF(
      pdr.used_representation)))) = 1))) = 0;
    WR6: SIZEOF(QUERY (pd <* USEDIN(SELF,
      'INTEGRATED_CNC_SCHEMA.PROPERTY_DEFINITION.DEFINITION') | NOT
      (SIZEOF(QUERY (pdr <* USEDIN(pd, 'INTEGRATED_CNC_SCHEMA.' +
      'PROPERTY_DEFINITION_REPRESENTATION.DEFINITION') | (
      'INTEGRATED_CNC_SCHEMA.PLANAR_SHAPE_REPRESENTATION' IN TYPEOF(
      pdr.used_representation)) AND (pdr.used_representation.name
      = 'profile limit')) <= 1))) = 0;
END_ENTITY; -- 10303-522: aic_machining_feature

ENTITY open_shell
  SUBTYPE OF (connected_face_set);
END_ENTITY; -- 10303-42: topology_schema

```

## ISO 10303-238:2007(E)

```
ENTITY or_expression
  SUBTYPE OF (multiple_arity_boolean_expression);
END_ENTITY; -- 13584-20: iso13584_expressions_schema

ENTITY ordinal_date
  SUBTYPE OF (date);
  day_component : day_in_year_number;
  WHERE
    WR1: NOT leap_year(SELF.year_component) AND ((1 <= day_component) AND (
      day_component <= 365)) OR leap_year(SELF.year_component) AND
      ((1 <= day_component) AND (day_component <= 366));
END_ENTITY; -- 10303-41: date_time_schema

ENTITY organization;
  id      : OPTIONAL identifier;
  name    : label;
  description : OPTIONAL text;
END_ENTITY; -- 10303-41: person_organization_schema

ENTITY organization_assignment
  ABSTRACT SUPERTYPE;
  assigned_organization : organization;
  role                  : organization_role;
END_ENTITY; -- 10303-41: management_resources_schema

ENTITY organization_role;
  name : label;
  DERIVE
    description : text := get_description_value(SELF);
  WHERE
    WR1: SIZEOF(USEDIN(SELF, 'INTEGRATED_CNC_SCHEMA.' +
      'DESCRIPTION_ATTRIBUTE.DESCRIBED_ITEM')) <= 1;
END_ENTITY; -- 10303-41: person_organization_schema

ENTITY organizational_address
  SUBTYPE OF (address);
  organizations : SET [1:?] OF organization;
  description   : OPTIONAL text;
END_ENTITY; -- 10303-41: person_organization_schema

ENTITY oriented_closed_shell
  SUBTYPE OF (closed_shell);
  closed_shell_element : closed_shell;
  orientation           : BOOLEAN;
  DERIVE
    SELF\connected_face_set.cfs_faces : SET [1:?] OF face :=
      conditional_reverse(SELF.orientation, SELF.
        closed_shell_element.cfs_faces);
  WHERE
    WR1: NOT ('INTEGRATED_CNC_SCHEMA.ORIENTED_CLOSED_SHELL' IN TYPEOF(SELF.
      closed_shell_element));
END_ENTITY; -- 10303-42: topology_schema

ENTITY oriented_edge
```

```

SUBTYPE OF (edge);
  edge_element : edge;
  orientation   : BOOLEAN;
DERIVE
  SELF\edge.edge_start : vertex := boolean_choose(SELF.orientation, SELF.
    edge_element.edge_start, SELF.edge_element.edge_end);
  SELF\edge.edge_end   : vertex := boolean_choose(SELF.orientation, SELF.
    edge_element.edge_end, SELF.edge_element.edge_start);
WHERE
  WR1: NOT ('INTEGRATED_CNC_SCHEMA.ORIENTED_EDGE' IN TYPEOF(SELF.
    edge_element));
END_ENTITY; -- 10303-42: topology_schema

ENTITY oriented_face
SUBTYPE OF (face);
  face_element : face;
  orientation   : BOOLEAN;
DERIVE
  SELF\face.bounds : SET [1:?] OF face_bound := conditional_reverse(SELF.
    orientation, SELF.face_element.bounds);
WHERE
  WR1: NOT ('INTEGRATED_CNC_SCHEMA.ORIENTED_FACE' IN TYPEOF(SELF.
    face_element));
END_ENTITY; -- 10303-42: topology_schema

ENTITY oriented_open_shell
SUBTYPE OF (open_shell);
  open_shell_element : open_shell;
  orientation         : BOOLEAN;
DERIVE
  SELF\connected_face_set.cfs_faces : SET [1:?] OF face :=
    conditional_reverse(SELF.orientation, SELF.
    open_shell_element.cfs_faces);
WHERE
  WR1: NOT ('INTEGRATED_CNC_SCHEMA.ORIENTED_OPEN_SHELL' IN TYPEOF(SELF.
    open_shell_element));
END_ENTITY; -- 10303-42: topology_schema

ENTITY oriented_path
SUBTYPE OF (path);
  path_element : path;
  orientation   : BOOLEAN;
DERIVE
  SELF\path.edge_list : LIST [1:?] OF UNIQUE oriented_edge :=
    conditional_reverse(SELF.orientation, SELF.path_element.
    edge_list);
WHERE
  WR1: NOT ('INTEGRATED_CNC_SCHEMA.ORIENTED_PATH' IN TYPEOF(SELF.
    path_element));
END_ENTITY; -- 10303-42: topology_schema

ENTITY outer_boundary_curve
SUBTYPE OF (boundary_curve);
END_ENTITY; -- 10303-42: geometry_schema

```

```

ENTITY outer_round
  SUBTYPE OF (feature_definition);
  WHERE
    WR1: NOT (SELF\characterized_object.description = 'outer diameter') OR
      (SIZEOF(QUERY (pd <* USEDIN(SELF,
        'INTEGRATED_CNC_SCHEMA.PROPERTY_DEFINITION.DEFINITION') | (
        SIZEOF(QUERY (pdr <* USEDIN(pd, 'INTEGRATED_CNC_SCHEMA.' +
        'PROPERTY_DEFINITION_REPRESENTATION.DEFINITION') | (
        'INTEGRATED_CNC_SCHEMA.SHAPE_REPRESENTATION_WITH_PARAMETERS'
        IN TYPEOF(pdr.used_representation)) AND (SIZEOF(pdr.
        used_representation.items) = 3))) = 1))) = 1);
    WR2: NOT (SELF\characterized_object.description =
      'outer diameter to shoulder') OR (SIZEOF(QUERY (pd <* USEDIN(
      SELF, 'INTEGRATED_CNC_SCHEMA.PROPERTY_DEFINITION.DEFINITION')
      | (SIZEOF(QUERY (pdr <* USEDIN(pd, 'INTEGRATED_CNC_SCHEMA.' +
      'PROPERTY_DEFINITION_REPRESENTATION.DEFINITION') | (
      'INTEGRATED_CNC_SCHEMA.SHAPE_REPRESENTATION_WITH_PARAMETERS'
      IN TYPEOF(pdr.used_representation)) AND ((2 <= SIZEOF(pdr.
      used_representation.items)) AND (SIZEOF(pdr.
      used_representation.items) <= 3)))) = 1))) = 1);
    WR3: SELF\characterized_object.description IN [ 'outer diameter',
      'outer diameter to shoulder' ];
    WR4: NOT (SELF\characterized_object.description = 'outer diameter') OR
      (SIZEOF(QUERY (pd <* USEDIN(SELF,
      'INTEGRATED_CNC_SCHEMA.PROPERTY_DEFINITION.DEFINITION') | NOT
      (SIZEOF(QUERY (impl_rep <* QUERY (pdr <* USEDIN(pd,
      'INTEGRATED_CNC_SCHEMA.' +
      'PROPERTY_DEFINITION_REPRESENTATION.DEFINITION') | (
      'INTEGRATED_CNC_SCHEMA.' +
      'SHAPE_REPRESENTATION_WITH_PARAMETERS' IN TYPEOF(pdr.
      used_representation))) | NOT (SIZEOF(QUERY (it <* impl_rep.
      used_representation.items | (SIZEOF([
      'INTEGRATED_CNC_SCHEMA.MEASURE_REPRESENTATION_ITEM',
      'INTEGRATED_CNC_SCHEMA.LENGTH_MEASURE_WITH_UNIT' ] * TYPEOF(
      it)) = 2) AND (it.name = 'length')))) = 1))) = 0))) = 0);
    WR5: SIZEOF(QUERY (pd <* USEDIN(SELF,
      'INTEGRATED_CNC_SCHEMA.PROPERTY_DEFINITION.DEFINITION') | NOT
      (SIZEOF(QUERY (impl_rep <* QUERY (pdr <* USEDIN(pd,
      'INTEGRATED_CNC_SCHEMA.' +
      'PROPERTY_DEFINITION_REPRESENTATION.DEFINITION') | (
      'INTEGRATED_CNC_SCHEMA.' +
      'SHAPE_REPRESENTATION_WITH_PARAMETERS' IN TYPEOF(pdr.
      used_representation))) | NOT (SIZEOF(QUERY (it <* impl_rep.
      used_representation.items | (SIZEOF([
      'INTEGRATED_CNC_SCHEMA.MEASURE_REPRESENTATION_ITEM',
      'INTEGRATED_CNC_SCHEMA.LENGTH_MEASURE_WITH_UNIT' ] * TYPEOF(
      it)) = 2) AND (it.name = 'diameter')))) = 1))) = 0))) = 0;
    WR6: NOT (SELF\characterized_object.description =
      'outer diameter to shoulder') OR (SIZEOF(QUERY (pds <* QUERY
      (pd <* USEDIN(SELF,
      'INTEGRATED_CNC_SCHEMA.PROPERTY_DEFINITION.DEFINITION') | (
      'INTEGRATED_CNC_SCHEMA.PRODUCT_DEFINITION_SHAPE' IN TYPEOF(pd
      ))) | NOT (SIZEOF(QUERY (sa_occ <* USEDIN(pds,

```



```

'INTEGRATED_CNC_SCHEMA.SHAPE_ASPECT.OF_SHAPE')| (sa_occ.
description = 'v-shape boundary occurrence') AND (SIZEOF(
QUERY (sdr <* QUERY (sar <* USEDIN(sa_occ,
'INTEGRATED_CNC_SCHEMA.SHAPE_ASPECT_RELATIONSHIP.' +
'RELATED_SHAPE_ASPECT')| (sar.description = 'profile usage')
AND ('INTEGRATED_CNC_SCHEMA.SHAPE_DEFINING_RELATIONSHIP' IN
TYPEOF(sar)))| ('INTEGRATED_CNC_SCHEMA.VEE_PROFILE' IN TYPEOF
(sdr.relying_shape_aspect)) AND (sdr.relying_shape_aspect.
description = 'v-shape')))) = 1))) = 1))) = 0);
WR7: NOT (SELF\characterized_object.description = 'outer diameter') OR
(SIZEOF(QUERY (pds <* QUERY (pd <* USEDIN(SELF,
'INTEGRATED_CNC_SCHEMA.PROPERTY_DEFINITION.DEFINITION')| (
'INTEGRATED_CNC_SCHEMA.PRODUCT_DEFINITION_SHAPE' IN TYPEOF(pd
)))| NOT (SIZEOF(QUERY (sa_occ <* USEDIN(pds,
'INTEGRATED_CNC_SCHEMA.SHAPE_ASPECT.OF_SHAPE')| (sa_occ.
description = 'reduced size occurrence') AND (SIZEOF(QUERY (
sdr <* QUERY (sar <* USEDIN(sa_occ,
'INTEGRATED_CNC_SCHEMA.SHAPE_ASPECT_RELATIONSHIP.' +
'RELATED_SHAPE_ASPECT')| (sar.description = 'taper usage')
AND ('INTEGRATED_CNC_SCHEMA.FEATURE_COMPONENT_RELATIONSHIP'
IN TYPEOF(sar)))| (('INTEGRATED_CNC_SCHEMA.TAPER' IN TYPEOF(
sdr.relying_shape_aspect)) AND (
'INTEGRATED_CNC_SCHEMA.OUTER_ROUND' IN TYPEOF(sdr.
related_shape_aspect.of_shape.definition))) AND (sdr.name =
'reduced size')))) = 1))) <= 1))) = 0);
WR8: NOT (SELF\characterized_object.description =
'outer diameter to shoulder') OR (SIZEOF(QUERY (pd <* USEDIN(
SELF, 'INTEGRATED_CNC_SCHEMA.PROPERTY_DEFINITION.DEFINITION')
| NOT (SIZEOF(QUERY (impl_rep <* QUERY (pdr <* USEDIN(pd,
'INTEGRATED_CNC_SCHEMA.' +
'PROPERTY_DEFINITION_REPRESENTATION.DEFINITION')| (
'INTEGRATED_CNC_SCHEMA.' +
'SHAPE_REPRESENTATION_WITH_PARAMETERS' IN TYPEOF(pdr.
used_representation)))| NOT (SIZEOF(QUERY (it <* impl_rep.
used_representation.items| (SIZEOF([
'INTEGRATED_CNC_SCHEMA.MEASURE_REPRESENTATION_ITEM',
'INTEGRATED_CNC_SCHEMA.LENGTH_MEASURE_WITH_UNIT' ] * TYPEOF(
it)) = 2) AND (it.name = 'length')) <= 1))) = 0))) = 0);
WR9: NOT (SELF\characterized_object.description =
'outer diameter to shoulder') OR (SIZEOF(QUERY (pd <* USEDIN(
SELF, 'INTEGRATED_CNC_SCHEMA.PROPERTY_DEFINITION.DEFINITION')
| NOT (SIZEOF(QUERY (impl_rep <* QUERY (pdr <* USEDIN(pd,
'INTEGRATED_CNC_SCHEMA.' +
'PROPERTY_DEFINITION_REPRESENTATION.DEFINITION')| (
'INTEGRATED_CNC_SCHEMA.' +
'SHAPE_REPRESENTATION_WITH_PARAMETERS' IN TYPEOF(pdr.
used_representation)))| NOT (SIZEOF(QUERY (it <* impl_rep.
used_representation.items| (SIZEOF([
'INTEGRATED_CNC_SCHEMA.MEASURE_REPRESENTATION_ITEM',
'INTEGRATED_CNC_SCHEMA.LENGTH_MEASURE_WITH_UNIT' ] * TYPEOF(
it)) = 2) AND (it.name = 'feature length')) <= 1))) = 0))) =
0);
END_ENTITY; -- 10303-522: aic_machining_feature

```

```

ENTITY outside_profile
  SUBTYPE OF (feature_definition);
  WHERE
    WR1: SIZEOF(QUERY (pd <* USEDIN(SELF,
      'INTEGRATED_CNC_SCHEMA.PROPERTY_DEFINITION.DEFINITION') | (
        SIZEOF(QUERY (pdr <* USEDIN(pd, 'INTEGRATED_CNC_SCHEMA.' +
          'PROPERTY_DEFINITION_REPRESENTATION.DEFINITION') | (
            'INTEGRATED_CNC_SCHEMA.SHAPE_REPRESENTATION_WITH_PARAMETERS'
            IN TYPEOF(pdr.used_representation)) AND (SIZEOF(pdr.
              used_representation.items) = 1))) = 1))) = 1;
    WR2: SIZEOF(QUERY (pds <* QUERY (pd <* USEDIN(SELF,
      'INTEGRATED_CNC_SCHEMA.PROPERTY_DEFINITION.DEFINITION') | (
        'INTEGRATED_CNC_SCHEMA.PRODUCT_DEFINITION_SHAPE' IN TYPEOF(pd
        ))) | NOT (SIZEOF(QUERY (sa_occ <* USEDIN(pds,
          'INTEGRATED_CNC_SCHEMA.SHAPE_ASPECT.OF_SHAPE') | (sa_occ.
            description IN [ 'boundary occurrence',
              'non-planar boundary occurrence',
                'partial circular boundary occurrence',
                  'closed circular boundary occurrence',
                    'open rectangular boundary occurrence',
                      'closed rectangular boundary occurrence' ]))) = 1))) = 0;
    WR3: NOT (SIZEOF(QUERY (pds <* QUERY (pd <* USEDIN(SELF,
      'INTEGRATED_CNC_SCHEMA.PROPERTY_DEFINITION.DEFINITION') | (
        'INTEGRATED_CNC_SCHEMA.PRODUCT_DEFINITION_SHAPE' IN TYPEOF(pd
        ))) | NOT (SIZEOF(QUERY (sa_occ <* USEDIN(pds,
          'INTEGRATED_CNC_SCHEMA.SHAPE_ASPECT.OF_SHAPE') | (sa_occ.
            description = 'boundary occurrence')))) = 1))) = 0) OR (SIZEOF
      (QUERY (pds <* QUERY (pd <* USEDIN(SELF,
        'INTEGRATED_CNC_SCHEMA.PROPERTY_DEFINITION.DEFINITION') | (
          'INTEGRATED_CNC_SCHEMA.PRODUCT_DEFINITION_SHAPE' IN TYPEOF(pd
          ))) | NOT (SIZEOF(QUERY (sa_occ <* USEDIN(pds,
            'INTEGRATED_CNC_SCHEMA.SHAPE_ASPECT.OF_SHAPE') | (SIZEOF(QUERY
              (sdr <* QUERY (sar <* USEDIN(sa_occ,
                'INTEGRATED_CNC_SCHEMA.SHAPE_ASPECT_RELATIONSHIP.' +
                  'RELATED_SHAPE_ASPECT') | (sar.description = 'profile usage')
                  AND ('INTEGRATED_CNC_SCHEMA.' + 'SHAPE_DEFINING_RELATIONSHIP'
                    IN TYPEOF(sar))) | (SIZEOF([
                      'INTEGRATED_CNC_SCHEMA.CIRCULAR_CLOSED_PROFILE',
                        'INTEGRATED_CNC_SCHEMA.NGON_CLOSED_PROFILE',
                          'INTEGRATED_CNC_SCHEMA.RECTANGULAR_CLOSED_PROFILE',
                            'INTEGRATED_CNC_SCHEMA.CLOSED_PATH_PROFILE',
                              'INTEGRATED_CNC_SCHEMA.SQUARE_U_PROFILE',
                                'INTEGRATED_CNC_SCHEMA.PARTIAL_CIRCULAR_PROFILE',
                                  'INTEGRATED_CNC_SCHEMA.ROUNDED_U_PROFILE',
                                    'INTEGRATED_CNC_SCHEMA.LINEAR_PROFILE',
                                      'INTEGRATED_CNC_SCHEMA.VEE_PROFILE',
                                        'INTEGRATED_CNC_SCHEMA.TEE_PROFILE',
                                          'INTEGRATED_CNC_SCHEMA.OPEN_PATH_PROFILE' ] * TYPEOF(sdr.
                                            relating_shape_aspect)) = 1) AND (sdr.relati
                                              ng_shape_aspect.
                                                description = 'outside boundary')))) = 1))) = 1))) = 0);
    WR4: NOT (SIZEOF(QUERY (pds <* QUERY (pd <* USEDIN(SELF,
      'INTEGRATED_CNC_SCHEMA.PROPERTY_DEFINITION.DEFINITION') | (
        'INTEGRATED_CNC_SCHEMA.PRODUCT_DEFINITION_SHAPE' IN TYPEOF(pd
        ))) | NOT (SIZEOF(QUERY (sa_occ <* USEDIN(pds,

```

```
'INTEGRATED_CNC_SCHEMA.SHAPE_ASPECT.OF_SHAPE')| (sa_occ.
description IN [ 'complex boundary occurrence',
'partial circular boundary occurrence',
'closed circular boundary occurrence',
'open rectangular boundary occurrence',
'closed rectangular boundary occurrence' ]))) = 1))) = 0) OR
(SIZEOF(QUERY (pds <* QUERY (pd <* USEDIN(SELF,
'INTEGRATED_CNC_SCHEMA.PROPERTY_DEFINITION.DEFINITION')| (
'INTEGRATED_CNC_SCHEMA.PRODUCT_DEFINITION_SHAPE' IN TYPEOF(pd
)))| NOT (SIZEOF(QUERY (sa_occ <* USEDIN(pds,
'INTEGRATED_CNC_SCHEMA.SHAPE_ASPECT.OF_SHAPE')| NOT (SIZEOF(
QUERY (sdr <* QUERY (sar <* USEDIN(sa_occ,
'INTEGRATED_CNC_SCHEMA.SHAPE_ASPECT_RELATIONSHIP.' +
'RELATED_SHAPE_ASPECT')| (sar.description =
'profile floor usage') AND (
'INTEGRATED_CNC_SCHEMA.FEATURE_COMPONENT_RELATIONSHIP' IN
TYPEOF(sar)))| ('INTEGRATED_CNC_SCHEMA.PROFILE_FLOOR' IN
TYPEOF(sdr.relying_shape_aspect)) AND (
'INTEGRATED_CNC_SCHEMA.OUTSIDE_PROFILE' IN TYPEOF(sdr.
related_shape_aspect.of_shape.definition)))) = 1))) = 0))) =
0);
```

```
WR5: NOT (SIZEOF(QUERY (pds <* QUERY (pd <* USEDIN(SELF,
'INTEGRATED_CNC_SCHEMA.PROPERTY_DEFINITION.DEFINITION')| (
'INTEGRATED_CNC_SCHEMA.PRODUCT_DEFINITION_SHAPE' IN TYPEOF(pd
)))| NOT (SIZEOF(QUERY (sa_occ <* USEDIN(pds,
'INTEGRATED_CNC_SCHEMA.SHAPE_ASPECT.OF_SHAPE')| (sa_occ.
description IN [ 'outside boundary',
'complex boundary occurrence',
'partial circular boundary occurrence',
'closed circular boundary occurrence',
'open rectangular boundary occurrence',
'closed rectangular boundary occurrence' ]))) = 1))) = 0) OR
(SIZEOF(QUERY (pds <* QUERY (pd <* USEDIN(SELF,
'INTEGRATED_CNC_SCHEMA.PROPERTY_DEFINITION.DEFINITION')| (
'INTEGRATED_CNC_SCHEMA.PRODUCT_DEFINITION_SHAPE' IN TYPEOF(pd
)))| NOT (SIZEOF(QUERY (sa_occ <* USEDIN(pds,
'INTEGRATED_CNC_SCHEMA.SHAPE_ASPECT.OF_SHAPE')| (SIZEOF(QUERY
(sdr <* QUERY (sar <* USEDIN(sa_occ,
'INTEGRATED_CNC_SCHEMA.SHAPE_ASPECT_RELATIONSHIP.' +
'RELATED_SHAPE_ASPECT')| (sar.description =
'path feature component usage') AND ('INTEGRATED_CNC_SCHEMA.'
+ 'SHAPE_DEFINING_RELATIONSHIP' IN TYPEOF(sar)))| ((SIZEOF([
'INTEGRATED_CNC_SCHEMA.PATH_FEATURE_COMPONENT' ] * TYPEOF(
sdr.relying_shape_aspect)) = 1) AND (sdr.name =
'profile swept shape')) AND (sdr.relying_shape_aspect.
description = 'linear')))) = 1))) = 1))) = 0);
```

```
WR6: NOT (SIZEOF(QUERY (pds <* QUERY (pd <* USEDIN(SELF,
'INTEGRATED_CNC_SCHEMA.PROPERTY_DEFINITION.DEFINITION')| (
'INTEGRATED_CNC_SCHEMA.PRODUCT_DEFINITION_SHAPE' IN TYPEOF(pd
)))| NOT (SIZEOF(QUERY (sa_occ <* USEDIN(pds,
'INTEGRATED_CNC_SCHEMA.SHAPE_ASPECT.OF_SHAPE')| (sa_occ.
description = 'complex boundary occurrence')))) = 1))) = 0) OR
(SIZEOF(QUERY (pds <* QUERY (pd <* USEDIN(SELF,
'INTEGRATED_CNC_SCHEMA.PROPERTY_DEFINITION.DEFINITION')| (
```

```

'INTEGRATED_CNC_SCHEMA.PRODUCT_DEFINITION_SHAPE' IN TYPEOF(pd
)))| NOT (SIZEOF(QUERY (sa_occ <* USEDIN(pds,
'INTEGRATED_CNC_SCHEMA.SHAPE_ASPECT.OF_SHAPE')| (SIZEOF(QUERY
(sdr <* QUERY (sar <* USEDIN(sa_occ,
'INTEGRATED_CNC_SCHEMA.SHAPE_ASPECT_RELATIONSHIP.' +
'RELATED_SHAPE_ASPECT')| (sar.description = 'profile usage')
AND ('INTEGRATED_CNC_SCHEMA.SHAPE_DEFINING_RELATIONSHIP' IN
TYPEOF(sar)))| (SIZEOF([
'INTEGRATED_CNC_SCHEMA.CIRCULAR_CLOSED_PROFILE',
'INTEGRATED_CNC_SCHEMA.NGON_CLOSED_PROFILE',
'INTEGRATED_CNC_SCHEMA.RECTANGULAR_CLOSED_PROFILE',
'INTEGRATED_CNC_SCHEMA.CLOSED_PATH_PROFILE',
'INTEGRATED_CNC_SCHEMA.SQUARE_U_PROFILE',
'INTEGRATED_CNC_SCHEMA.PARTIAL_CIRCULAR_PROFILE',
'INTEGRATED_CNC_SCHEMA.ROUNDED_U_PROFILE',
'INTEGRATED_CNC_SCHEMA.VEE_PROFILE',
'INTEGRATED_CNC_SCHEMA.TEE_PROFILE',
'INTEGRATED_CNC_SCHEMA.LINEAR_PROFILE',
'INTEGRATED_CNC_SCHEMA.OPEN_PATH_PROFILE' ] * TYPEOF(sdr.
relating_shape_aspect)) = 1))) = 1))) = 1))) = 0);
WR7: NOT (SIZEOF(QUERY (pds <* QUERY (pd <* USEDIN(SELF,
'INTEGRATED_CNC_SCHEMA.PROPERTY_DEFINITION.DEFINITION')| (
'INTEGRATED_CNC_SCHEMA.PRODUCT_DEFINITION_SHAPE' IN TYPEOF(pd
)))| NOT (SIZEOF(QUERY (sa_occ <* USEDIN(pds,
'INTEGRATED_CNC_SCHEMA.SHAPE_ASPECT.OF_SHAPE')| (sa_occ.
description = 'partial circular boundary occurrence')))) = 1))
) = 0) OR (SIZEOF(QUERY (pds <* QUERY (pd <* USEDIN(SELF,
'INTEGRATED_CNC_SCHEMA.PROPERTY_DEFINITION.DEFINITION')| (
'INTEGRATED_CNC_SCHEMA.PRODUCT_DEFINITION_SHAPE' IN TYPEOF(pd
)))| NOT (SIZEOF(QUERY (sa_occ <* USEDIN(pds,
'INTEGRATED_CNC_SCHEMA.SHAPE_ASPECT.OF_SHAPE')| (SIZEOF(QUERY
(sdr <* QUERY (sar <* USEDIN(sa_occ,
'INTEGRATED_CNC_SCHEMA.SHAPE_ASPECT_RELATIONSHIP.' +
'RELATED_SHAPE_ASPECT')| (sar.description = 'profile usage')
AND ('INTEGRATED_CNC_SCHEMA.SHAPE_DEFINING_RELATIONSHIP' IN
TYPEOF(sar)))| (
'INTEGRATED_CNC_SCHEMA.PARTIAL_CIRCULAR_PROFILE' IN TYPEOF(
sdr.relying_shape_aspect)))) = 1))) = 1))) = 0);
WR8: NOT (SIZEOF(QUERY (pds <* QUERY (pd <* USEDIN(SELF,
'INTEGRATED_CNC_SCHEMA.PROPERTY_DEFINITION.DEFINITION')| (
'INTEGRATED_CNC_SCHEMA.PRODUCT_DEFINITION_SHAPE' IN TYPEOF(pd
)))| NOT (SIZEOF(QUERY (sa_occ <* USEDIN(pds,
'INTEGRATED_CNC_SCHEMA.SHAPE_ASPECT.OF_SHAPE')| (sa_occ.
description = 'closed circular boundary occurrence')))) = 1)))
= 0) OR (SIZEOF(QUERY (pds <* QUERY (pd <* USEDIN(SELF,
'INTEGRATED_CNC_SCHEMA.PROPERTY_DEFINITION.DEFINITION')| (
'INTEGRATED_CNC_SCHEMA.PRODUCT_DEFINITION_SHAPE' IN TYPEOF(pd
)))| NOT (SIZEOF(QUERY (sa_occ <* USEDIN(pds,
'INTEGRATED_CNC_SCHEMA.SHAPE_ASPECT.OF_SHAPE')| (SIZEOF(QUERY
(sdr <* QUERY (sar <* USEDIN(sa_occ,
'INTEGRATED_CNC_SCHEMA.SHAPE_ASPECT_RELATIONSHIP.' +
'RELATED_SHAPE_ASPECT')| (sar.description = 'profile usage')
AND ('INTEGRATED_CNC_SCHEMA.SHAPE_DEFINING_RELATIONSHIP' IN
TYPEOF(sar)))| (

```

```

        'INTEGRATED_CNC_SCHEMA.CIRCULAR_CLOSED_PROFILE' IN TYPEOF(sdr
        .relating_shape_aspect)))) = 1))) = 1))) = 0);
WR9: NOT (SIZEOF(QUERY (pds <* QUERY (pd <* USEDIN(SELF,
        'INTEGRATED_CNC_SCHEMA.PROPERTY_DEFINITION.DEFINITION')| (
        'INTEGRATED_CNC_SCHEMA.PRODUCT_DEFINITION_SHAPE' IN TYPEOF(pd
        )))| NOT (SIZEOF(QUERY (sa_occ <* USEDIN(pds,
        'INTEGRATED_CNC_SCHEMA.SHAPE_ASPECT.OF_SHAPE')| (sa_occ.
        description = 'open rectangular boundary occurrence')))) = 1))
        ) = 0) OR (SIZEOF(QUERY (pds <* QUERY (pd <* USEDIN(SELF,
        'INTEGRATED_CNC_SCHEMA.PROPERTY_DEFINITION.DEFINITION')| (
        'INTEGRATED_CNC_SCHEMA.PRODUCT_DEFINITION_SHAPE' IN TYPEOF(pd
        )))| NOT (SIZEOF(QUERY (sa_occ <* USEDIN(pds,
        'INTEGRATED_CNC_SCHEMA.SHAPE_ASPECT.OF_SHAPE')| (SIZEOF(QUERY
        (sdr <* QUERY (sar <* USEDIN(sa_occ,
        'INTEGRATED_CNC_SCHEMA.SHAPE_ASPECT_RELATIONSHIP.' +
        'RELATED_SHAPE_ASPECT')| (sar.description = 'profile usage')
        AND ('INTEGRATED_CNC_SCHEMA.SHAPE_DEFINING_RELATIONSHIP' IN
        TYPEOF(sar)))| ('INTEGRATED_CNC_SCHEMA.SQUARE_U_PROFILE' IN
        TYPEOF(sdr.relating_shape_aspect)))))) = 1))) = 1))) = 0);
WR10: NOT (SIZEOF(QUERY (pds <* QUERY (pd <* USEDIN(SELF,
        'INTEGRATED_CNC_SCHEMA.PROPERTY_DEFINITION.DEFINITION')| (
        'INTEGRATED_CNC_SCHEMA.PRODUCT_DEFINITION_SHAPE' IN TYPEOF(pd
        )))| NOT (SIZEOF(QUERY (sa_occ <* USEDIN(pds,
        'INTEGRATED_CNC_SCHEMA.SHAPE_ASPECT.OF_SHAPE')| (sa_occ.
        description = 'closed rectangular boundary occurrence')))) = 1
        ))) = 0) OR (SIZEOF(QUERY (pds <* QUERY (pd <* USEDIN(SELF,
        'INTEGRATED_CNC_SCHEMA.PROPERTY_DEFINITION.DEFINITION')| (
        'INTEGRATED_CNC_SCHEMA.PRODUCT_DEFINITION_SHAPE' IN TYPEOF(pd
        )))| NOT (SIZEOF(QUERY (sa_occ <* USEDIN(pds,
        'INTEGRATED_CNC_SCHEMA.SHAPE_ASPECT.OF_SHAPE')| (SIZEOF(QUERY
        (sdr <* QUERY (sar <* USEDIN(sa_occ,
        'INTEGRATED_CNC_SCHEMA.SHAPE_ASPECT_RELATIONSHIP.' +
        'RELATED_SHAPE_ASPECT')| (sar.description = 'profile usage')
        AND ('INTEGRATED_CNC_SCHEMA.SHAPE_DEFINING_RELATIONSHIP' IN
        TYPEOF(sar)))| (
        'INTEGRATED_CNC_SCHEMA.RECTANGULAR_CLOSED_PROFILE' IN TYPEOF(
        sdr.relating_shape_aspect)))))) = 1))) = 1))) = 0);
WR11: (SIZEOF(QUERY (pds <* QUERY (pd <* USEDIN(SELF,
        'INTEGRATED_CNC_SCHEMA.PROPERTY_DEFINITION.DEFINITION')| (
        'INTEGRATED_CNC_SCHEMA.PRODUCT_DEFINITION_SHAPE' IN TYPEOF(pd
        )))| NOT (SIZEOF(QUERY (sa_occ <* USEDIN(pds,
        'INTEGRATED_CNC_SCHEMA.SHAPE_ASPECT.OF_SHAPE')| (sa_occ.
        description IN [ 'boundary occurrence',
        'complex boundary occurrence',
        'partial circular boundary occurrence',
        'closed circular boundary occurrence',
        'open rectangular boundary occurrence',
        'closed rectangular boundary occurrence' ])))) = 1))) = 0) OR
        (SIZEOF(QUERY (pd <* USEDIN(SELF,
        'INTEGRATED_CNC_SCHEMA.PROPERTY_DEFINITION.DEFINITION')| NOT
        (SIZEOF(QUERY (pdr <* USEDIN(pd, 'INTEGRATED_CNC_SCHEMA.' +
        'PROPERTY_DEFINITION_REPRESENTATION.DEFINITION')| (
        'INTEGRATED_CNC_SCHEMA.DIRECTION_SHAPE_REPRESENTATION' IN
        TYPEOF(pdr.used_representation)) AND (pdr.used_representation

```

```

        .name = 'removal direction')) = 1))) = 0);
    WR12: SIZEOF(QUERY (pdr <* get_property_definition_representations(SELF
        )| ('INTEGRATED_CNC_SCHEMA.PLANAR_SHAPE_REPRESENTATION' IN
        TYPEOF(pdr.used_representation)) AND (pdr.used_representation
        .name = 'maximum feature limit')))) >= 0;
END_ENTITY; -- 10303-522: aic_machining_feature

```

```

ENTITY parabola
  SUBTYPE OF (conic);
  focal_dist : length_measure;
  WHERE
    WR1: focal_dist <> 0.0;
END_ENTITY; -- 10303-42: geometry_schema

```

```

ENTITY parallel_offset
  SUBTYPE OF (derived_shape_aspect);
  offset : measure_with_unit;
  WHERE
    WR1: SIZEOF(SELF\derived_shape_aspect.deriving_relationships) = 1;
END_ENTITY; -- 10303-47: shape_aspect_definition_schema

```

```

ENTITY parallelism_tolerance
  SUBTYPE OF (geometric_tolerance_with_datum_reference);
  WHERE
    WR1: SIZEOF(SELF\geometric_tolerance_with_datum_reference.datum_system)
        < 3;
END_ENTITY; -- 10303-519: aic_geometric_tolerances

```

```

ENTITY parametric_representation_context
  SUBTYPE OF (representation_context);
END_ENTITY; -- 10303-43: representation_schema

```

```

ENTITY partial_circular_profile
  SUBTYPE OF (shape_aspect);
  WHERE
    WR1: 'INTEGRATED_CNC_SCHEMA.FEATURE_COMPONENT_DEFINITION' IN TYPEOF(
        SELF.of_shape.definition);
    WR2: SIZEOF(QUERY (pd <* USEDIN(SELF,
        'INTEGRATED_CNC_SCHEMA.PROPERTY_DEFINITION.DEFINITION')| NOT
        (SIZEOF(QUERY (pdr <* USEDIN(pd, 'INTEGRATED_CNC_SCHEMA.' +
        'PROPERTY_DEFINITION_REPRESENTATION.DEFINITION')| (
        'INTEGRATED_CNC_SCHEMA.' +
        'SHAPE_REPRESENTATION_WITH_PARAMETERS' IN TYPEOF(pdr.
        used_representation)))) = 1))) = 0;
    WR3: SIZEOF(QUERY (pd <* USEDIN(SELF,
        'INTEGRATED_CNC_SCHEMA.PROPERTY_DEFINITION.DEFINITION')| NOT
        (SIZEOF(QUERY (impl_rep <* QUERY (pdr <* USEDIN(pd,
        'INTEGRATED_CNC_SCHEMA.' +
        'PROPERTY_DEFINITION_REPRESENTATION.DEFINITION')| (
        'INTEGRATED_CNC_SCHEMA.' +
        'SHAPE_REPRESENTATION_WITH_PARAMETERS' IN TYPEOF(pdr.
        used_representation)))| NOT (SIZEOF(impl_rep.
        used_representation.items) >= 3)))) = 0))) = 0;
    WR4: SIZEOF(QUERY (pd <* USEDIN(SELF,

```

```

'INTEGRATED_CNC_SCHEMA.PROPERTY_DEFINITION.DEFINITION')| NOT
(SIZEOF(QUERY (impl_rep <* QUERY (pdr <* USEDIN(pd,
'INTEGRATED_CNC_SCHEMA.' +
'PROPERTY_DEFINITION_REPRESENTATION.DEFINITION')| (
'INTEGRATED_CNC_SCHEMA.' +
'SHAPE_REPRESENTATION_WITH_PARAMETERS' IN TYPEOF(pdr.
used_representation)))| NOT (SIZEOF(QUERY (it <* impl_rep.
used_representation.items| ('INTEGRATED_CNC_SCHEMA.PLACEMENT'
IN TYPEOF(it)) AND (it.name = 'orientation')))) = 1))) = 0)))
= 0;
WR5: SIZEOF(QUERY (pd <* USEDIN(SELF,
'INTEGRATED_CNC_SCHEMA.PROPERTY_DEFINITION.DEFINITION')| NOT
(SIZEOF(QUERY (impl_rep <* QUERY (pdr <* USEDIN(pd,
'INTEGRATED_CNC_SCHEMA.' +
'PROPERTY_DEFINITION_REPRESENTATION.DEFINITION')| (
'INTEGRATED_CNC_SCHEMA.' +
'SHAPE_REPRESENTATION_WITH_PARAMETERS' IN TYPEOF(pdr.
used_representation)))| NOT (SIZEOF(QUERY (it <* impl_rep.
used_representation.items| (SIZEOF([
'INTEGRATED_CNC_SCHEMA.MEASURE_REPRESENTATION_ITEM',
'INTEGRATED_CNC_SCHEMA.LENGTH_MEASURE_WITH_UNIT' ] * TYPEOF(
it)) = 2) AND (it.name = 'radius')))) = 1))) = 0))) = 0;
WR6: SIZEOF(QUERY (pd <* USEDIN(SELF,
'INTEGRATED_CNC_SCHEMA.PROPERTY_DEFINITION.DEFINITION')| NOT
(SIZEOF(QUERY (impl_rep <* QUERY (pdr <* USEDIN(pd,
'INTEGRATED_CNC_SCHEMA.' +
'PROPERTY_DEFINITION_REPRESENTATION.DEFINITION')| (
'INTEGRATED_CNC_SCHEMA.' +
'SHAPE_REPRESENTATION_WITH_PARAMETERS' IN TYPEOF(pdr.
used_representation)))| NOT (SIZEOF(QUERY (it <* impl_rep.
used_representation.items| (SIZEOF([
'INTEGRATED_CNC_SCHEMA.MEASURE_REPRESENTATION_ITEM',
'INTEGRATED_CNC_SCHEMA.PLANE_ANGLE_MEASURE_WITH_UNIT' ] *
TYPEOF(it)) = 2) AND (it.name = 'sweep angle')))) = 1))) = 0))
) = 0;
WR7: SIZEOF(QUERY (pd <* USEDIN(SELF,
'INTEGRATED_CNC_SCHEMA.PROPERTY_DEFINITION.DEFINITION')| NOT
(SIZEOF(QUERY (pdr <* USEDIN(pd, 'INTEGRATED_CNC_SCHEMA.' +
'PROPERTY_DEFINITION_REPRESENTATION.DEFINITION')| (
'INTEGRATED_CNC_SCHEMA.PLANAR_SHAPE_REPRESENTATION' IN TYPEOF
(pdr.used_representation)) AND (pdr.used_representation.name
= 'profile limit')))) <= 1))) = 0;
END_ENTITY; -- 10303-522: aic_machining_feature

ENTITY path
  SUPERTYPE OF (ONEOF(edge_loop, oriented_path))
  SUBTYPE OF (topological_representation_item);
  edge_list : LIST [1:?] OF UNIQUE oriented_edge;
  WHERE
    WR1: path_head_to_tail(SELF);
END_ENTITY; -- 10303-42: topology_schema

ENTITY path_feature_component
  SUBTYPE OF (shape_aspect);

```

WHERE

```

WR1: 'INTEGRATED_CNC_SCHEMA.FEATURE_COMPONENT_DEFINITION' IN TYPEOF(
      SELF.of_shape.definition);
WR2: SELF.description IN [ 'partial circular', 'complete circular',
      'linear', 'complex' ];
WR3: NOT (SELF.description = 'complex') OR (SIZEOF(QUERY (pd <* USEDIN(
      SELF, 'INTEGRATED_CNC_SCHEMA.PROPERTY_DEFINITION.DEFINITION')
      | NOT (SIZEOF(QUERY (pdr <* USEDIN(pdr,
      'INTEGRATED_CNC_SCHEMA.' +
      'PROPERTY_DEFINITION_REPRESENTATION.DEFINITION')| (
      'INTEGRATED_CNC_SCHEMA.' +
      'SHAPE_REPRESENTATION_WITH_PARAMETERS' IN TYPEOF(pdr.
      used_representation)))) = 1))) = 0);
WR4: SIZEOF(QUERY (pd <* USEDIN(SELF,
      'INTEGRATED_CNC_SCHEMA.PROPERTY_DEFINITION.DEFINITION')| NOT
      (SIZEOF(QUERY (impl_rep <* QUERY (pdr <* USEDIN(pdr,
      'INTEGRATED_CNC_SCHEMA.' +
      'PROPERTY_DEFINITION_REPRESENTATION.DEFINITION')| (
      'INTEGRATED_CNC_SCHEMA.' +
      'SHAPE_REPRESENTATION_WITH_PARAMETERS' IN TYPEOF(pdr.
      used_representation)))| NOT (SIZEOF(QUERY (it <* impl_rep.
      used_representation.items| ('INTEGRATED_CNC_SCHEMA.PLACEMENT'
      IN TYPEOF(it)) AND (it.name = 'orientation')) = 1))) = 0)))
      = 0;
WR5: NOT (SELF.description = 'partial circular') OR (SIZEOF(QUERY (pd
      <* USEDIN(SELF,
      'INTEGRATED_CNC_SCHEMA.PROPERTY_DEFINITION.DEFINITION')| NOT
      (SIZEOF(QUERY (impl_rep <* QUERY (pdr <* USEDIN(pdr,
      'INTEGRATED_CNC_SCHEMA.' +
      'PROPERTY_DEFINITION_REPRESENTATION.DEFINITION')| (
      'INTEGRATED_CNC_SCHEMA.' +
      'SHAPE_REPRESENTATION_WITH_PARAMETERS' IN TYPEOF(pdr.
      used_representation)))| NOT (SIZEOF(impl_rep.
      used_representation.items) = 3))) = 0))) = 0);
WR6: NOT (SELF.description = 'partial circular') OR (SIZEOF(QUERY (pd
      <* USEDIN(SELF,
      'INTEGRATED_CNC_SCHEMA.PROPERTY_DEFINITION.DEFINITION')| NOT
      (SIZEOF(QUERY (impl_rep <* QUERY (pdr <* USEDIN(pdr,
      'INTEGRATED_CNC_SCHEMA.' +
      'PROPERTY_DEFINITION_REPRESENTATION.DEFINITION')| (
      'INTEGRATED_CNC_SCHEMA.' +
      'SHAPE_REPRESENTATION_WITH_PARAMETERS' IN TYPEOF(pdr.
      used_representation)))| NOT (SIZEOF(QUERY (it <* impl_rep.
      used_representation.items| (SIZEOF([
      'INTEGRATED_CNC_SCHEMA.MEASURE_REPRESENTATION_ITEM',
      'INTEGRATED_CNC_SCHEMA.LENGTH_MEASURE_WITH_UNIT' ] * TYPEOF(
      it)) = 2) AND (it.name = 'radius')) = 1))) = 0))) = 0);
WR7: NOT (SELF.description = 'partial circular') OR (SIZEOF(QUERY (pd
      <* USEDIN(SELF,
      'INTEGRATED_CNC_SCHEMA.PROPERTY_DEFINITION.DEFINITION')| NOT
      (SIZEOF(QUERY (impl_rep <* QUERY (pdr <* USEDIN(pdr,
      'INTEGRATED_CNC_SCHEMA.' +
      'PROPERTY_DEFINITION_REPRESENTATION.DEFINITION')| (
      'INTEGRATED_CNC_SCHEMA.' +

```



```

'SHAPE_REPRESENTATION_WITH_PARAMETERS' IN TYPEOF(pdr.
used_representation)))| NOT (SIZEOF(QUERY (it <* impl_rep.
used_representation.items| (SIZEOF([
'INTEGRATED_CNC_SCHEMA.MEASURE_REPRESENTATION_ITEM',
'INTEGRATED_CNC_SCHEMA.PLANE_ANGLE_MEASURE_WITH_UNIT' ] *
TYPEOF(it)) = 2) AND (it.name = 'sweep angle')) = 1))) = 0))
) = 0);
WR8: NOT (SELF.description = 'complete circular') OR (SIZEOF(QUERY (pd
<* USEDIN(SELF,
'INTEGRATED_CNC_SCHEMA.PROPERTY_DEFINITION.DEFINITION')| NOT
(SIZEOF(QUERY (impl_rep <* QUERY (pdr <* USEDIN(pd,
'INTEGRATED_CNC_SCHEMA.' +
'PROPERTY_DEFINITION_REPRESENTATION.DEFINITION')| (
'INTEGRATED_CNC_SCHEMA.' +
'SHAPE_REPRESENTATION_WITH_PARAMETERS' IN TYPEOF(pdr.
used_representation)))| NOT (SIZEOF(impl_rep.
used_representation.items) = 2))) = 0))) = 0);
WR9: NOT (SELF.description = 'complete circular') OR (SIZEOF(QUERY (pd
<* USEDIN(SELF,
'INTEGRATED_CNC_SCHEMA.PROPERTY_DEFINITION.DEFINITION')| NOT
(SIZEOF(QUERY (impl_rep <* QUERY (pdr <* USEDIN(pd,
'INTEGRATED_CNC_SCHEMA.' +
'PROPERTY_DEFINITION_REPRESENTATION.DEFINITION')| (
'INTEGRATED_CNC_SCHEMA.' +
'SHAPE_REPRESENTATION_WITH_PARAMETERS' IN TYPEOF(pdr.
used_representation)))| NOT (SIZEOF(QUERY (it <* impl_rep.
used_representation.items| (SIZEOF([
'INTEGRATED_CNC_SCHEMA.MEASURE_REPRESENTATION_ITEM',
'INTEGRATED_CNC_SCHEMA.LENGTH_MEASURE_WITH_UNIT' ] * TYPEOF(
it)) = 2) AND (it.name = 'radius')) = 1))) = 0))) = 0);
WR10: NOT (SELF.description = 'linear') OR (SIZEOF(QUERY (pd <* USEDIN(
SELF, 'INTEGRATED_CNC_SCHEMA.PROPERTY_DEFINITION.DEFINITION')
| NOT (SIZEOF(QUERY (impl_rep <* QUERY (pdr <* USEDIN(pd,
'INTEGRATED_CNC_SCHEMA.' +
'PROPERTY_DEFINITION_REPRESENTATION.DEFINITION')| (
'INTEGRATED_CNC_SCHEMA.' +
'SHAPE_REPRESENTATION_WITH_PARAMETERS' IN TYPEOF(pdr.
used_representation)))| NOT (SIZEOF(impl_rep.
used_representation.items) = 2))) = 0))) = 0);
WR11: NOT (SELF.description = 'linear') OR (SIZEOF(QUERY (pd <* USEDIN(
SELF, 'INTEGRATED_CNC_SCHEMA.PROPERTY_DEFINITION.DEFINITION')
| NOT (SIZEOF(QUERY (impl_rep <* QUERY (pdr <* USEDIN(pd,
'INTEGRATED_CNC_SCHEMA.' +
'PROPERTY_DEFINITION_REPRESENTATION.DEFINITION')| (
'INTEGRATED_CNC_SCHEMA.' +
'SHAPE_REPRESENTATION_WITH_PARAMETERS' IN TYPEOF(pdr.
used_representation)))| NOT (SIZEOF(QUERY (it <* impl_rep.
used_representation.items| (SIZEOF([
'INTEGRATED_CNC_SCHEMA.MEASURE_REPRESENTATION_ITEM',
'INTEGRATED_CNC_SCHEMA.LENGTH_MEASURE_WITH_UNIT' ] * TYPEOF(
it)) = 2) AND (it.name = 'distance')) = 1))) = 0))) = 0);
WR12: NOT (SELF.description = 'linear') OR (SIZEOF(QUERY (pd <* USEDIN(
SELF, 'INTEGRATED_CNC_SCHEMA.PROPERTY_DEFINITION.DEFINITION')
| NOT (SIZEOF(QUERY (pdr <* USEDIN(pd,

```

```

        'INTEGRATED_CNC_SCHEMA.' +
        'PROPERTY_DEFINITION_REPRESENTATION.DEFINITION')| (
        'INTEGRATED_CNC_SCHEMA.DIRECTION_SHAPE_REPRESENTATION' IN
        TYPEOF(pdr.used_representation))) = 1))) = 0);
WR13: NOT (SELF.description = 'complex') OR (SIZEOF(QUERY (pd <* USEDIN
        (SELF, 'INTEGRATED_CNC_SCHEMA.PROPERTY_DEFINITION.DEFINITION'
        )| NOT (SIZEOF(QUERY (pdr <* USEDIN(pdr,
        'INTEGRATED_CNC_SCHEMA.' +
        'PROPERTY_DEFINITION_REPRESENTATION.DEFINITION')| ((
        'INTEGRATED_CNC_SCHEMA.PATH_SHAPE_REPRESENTATION' IN TYPEOF(
        pdr.used_representation)) AND (pdr.used_representation.name =
        'sweep path')) AND (SIZEOF(QUERY (srwp_i <* pdr.
        used_representation.items| (srwp_i.name = 'profile shape'))
        = 1))) = 1))) = 0);
END_ENTITY; -- 10303-522: aic_machining_feature

ENTITY path_shape_representation
  SUBTYPE OF (shape_representation);
  WHERE
    WR1: SIZEOF(SELF.items) >= 1;
    WR2: SIZEOF(QUERY (i <* SELF.items| (SIZEOF([
        'INTEGRATED_CNC_SCHEMA.BOUNDED_CURVE',
        'INTEGRATED_CNC_SCHEMA.EDGE_CURVE',
        'INTEGRATED_CNC_SCHEMA.PATH' ] * TYPEOF(i)) = 1))) >= 1;
END_ENTITY; -- 10303-522: aic_machining_feature

ENTITY pattern_offset_membership
  SUBTYPE OF (feature_component_relationship);
  WHERE
    WR1: SIZEOF(QUERY (fcr <* QUERY (sar <* USEDIN(SELF.
        relating_shape_aspect,
        'INTEGRATED_CNC_SCHEMA.SHAPE_ASPECT_RELATIONSHIP.' +
        'RELATING_SHAPE_ASPECT')| (
        'INTEGRATED_CNC_SCHEMA.FEATURE_COMPONENT_RELATIONSHIP' IN
        TYPEOF(sar)) AND (sar :<>: SELF))| (SIZEOF(QUERY (pdr <*
        QUERY (pd <* USEDIN(fcr.related_shape_aspect.of_shape,
        'INTEGRATED_CNC_SCHEMA.PROPERTY_DEFINITION.DEFINITION')| (
        'INTEGRATED_CNC_SCHEMA.PRODUCT_DEFINITION_SHAPE' IN TYPEOF(pd
        )))| (SIZEOF([ 'INTEGRATED_CNC_SCHEMA.CIRCULAR_PATTERN',
        'INTEGRATED_CNC_SCHEMA.RECTANGULAR_PATTERN' ] * TYPEOF(pdr.
        definition)) = 1))) = 0))) = 0);
    WR2: SIZEOF(QUERY (fcr <* QUERY (sar <* USEDIN(SELF.
        related_shape_aspect,
        'INTEGRATED_CNC_SCHEMA.SHAPE_ASPECT_RELATIONSHIP.' +
        'RELATED_SHAPE_ASPECT')| (
        'INTEGRATED_CNC_SCHEMA.FEATURE_COMPONENT_RELATIONSHIP' IN
        TYPEOF(sar)) AND (sar :<>: SELF))| (fcr.description =
        'modified pattern') AND (
        'INTEGRATED_CNC_SCHEMA.MODIFIED_PATTERN' IN TYPEOF(fcr.
        relating_shape_aspect)))) >= 1;
    WR3: SIZEOF(QUERY (fcr <* QUERY (sar <* USEDIN(SELF.
        related_shape_aspect,
        'INTEGRATED_CNC_SCHEMA.SHAPE_ASPECT_RELATIONSHIP.' +
        'RELATED_SHAPE_ASPECT')| (

```

```

'INTEGRATED_CNC_SCHEMA.FEATURE_COMPONENT_RELATIONSHIP' IN
TYPEOF(sar)) AND (sar :<>: SELF)| (
'INTEGRATED_CNC_SCHEMA.MODIFIED_PATTERN' IN TYPEOF(fcr.
relating_shape_aspect)) AND NOT (SIZEOF(QUERY (modfcr <*
QUERY (modsar <* USEDIN(fcr.relating_shape_aspect,
'INTEGRATED_CNC_SCHEMA.' +
'SHAPE_ASPECT_RELATIONSHIP.RELATING_SHAPE_ASPECT')| (SIZEOF([
'INTEGRATED_CNC_SCHEMA.CIRCULAR_PATTERN',
'INTEGRATED_CNC_SCHEMA.RECTANGULAR_PATTERN' ] * TYPEOF(modsar
.related_shape_aspect.of_shape.definition)) = 1) AND (modsar
:<>: fcr))| NOT (modfcr.related_shape_aspect.of_shape.
definition :=: SELF.relating_shape_aspect.of_shape.definition
))) = 0))) = 0;
WR4: NOT ('INTEGRATED_CNC_SCHEMA.RECTANGULAR_PATTERN' IN TYPEOF(SELF.
relating_shape_aspect.of_shape.definition)) OR (SIZEOF(QUERY
(pd <* USEDIN(SELF.related_shape_aspect,
'INTEGRATED_CNC_SCHEMA.PROPERTY_DEFINITION.DEFINITION')| NOT
(SIZEOF(USEDIN(pd, 'INTEGRATED_CNC_SCHEMA.' +
'PROPERTY_DEFINITION_REPRESENTATION.DEFINITION')) = 2))) = 0)
;
WR5: NOT ('INTEGRATED_CNC_SCHEMA.CIRCULAR_PATTERN' IN TYPEOF(SELF.
relating_shape_aspect.of_shape.definition)) OR (SIZEOF(QUERY
(pd <* USEDIN(SELF.related_shape_aspect,
'INTEGRATED_CNC_SCHEMA.PROPERTY_DEFINITION.DEFINITION')| NOT
(SIZEOF(USEDIN(pd, 'INTEGRATED_CNC_SCHEMA.' +
'PROPERTY_DEFINITION_REPRESENTATION.DEFINITION')) = 1))) = 0)
;
WR6: NOT ('INTEGRATED_CNC_SCHEMA.CIRCULAR_PATTERN' IN TYPEOF(SELF.
relating_shape_aspect.of_shape.definition)) OR (SIZEOF(QUERY
(pd <* USEDIN(SELF.related_shape_aspect,
'INTEGRATED_CNC_SCHEMA.PROPERTY_DEFINITION.DEFINITION')| NOT
(SIZEOF(QUERY (pdr <* USEDIN(pd, 'INTEGRATED_CNC_SCHEMA.' +
'PROPERTY_DEFINITION_REPRESENTATION.DEFINITION')| NOT (SIZEOF
(pdr.used_representation.items) = 2))) = 0))) = 0);
WR7: NOT ('INTEGRATED_CNC_SCHEMA.CIRCULAR_PATTERN' IN TYPEOF(SELF.
relating_shape_aspect.of_shape.definition)) OR (SIZEOF(QUERY
(pd <* USEDIN(SELF.related_shape_aspect,
'INTEGRATED_CNC_SCHEMA.PROPERTY_DEFINITION.DEFINITION')| NOT
(SIZEOF(QUERY (impl_rep <* QUERY (pdr <* USEDIN(pd,
'INTEGRATED_CNC_SCHEMA.' +
'PROPERTY_DEFINITION_REPRESENTATION.DEFINITION')| (
'INTEGRATED_CNC_SCHEMA.' +
'SHAPE_REPRESENTATION_WITH_PARAMETERS' IN TYPEOF(pdr.
used_representation)))| NOT (SIZEOF(QUERY (it <* impl_rep.
used_representation.items| ((
'INTEGRATED_CNC_SCHEMA.MEASURE_REPRESENTATION_ITEM' IN TYPEOF
(it)) AND ('INTEGRATED_CNC_SCHEMA.COUNT_MEASURE' IN TYPEOF(it
\measure_with_unit.value_component))) AND (it.name =
'index number')))) = 1))) = 0))) = 0);
WR8: NOT ('INTEGRATED_CNC_SCHEMA.CIRCULAR_PATTERN' IN TYPEOF(SELF.
relating_shape_aspect.of_shape.definition)) OR (SIZEOF(QUERY
(pd <* USEDIN(SELF.related_shape_aspect,
'INTEGRATED_CNC_SCHEMA.PROPERTY_DEFINITION.DEFINITION')| NOT
(SIZEOF(QUERY (impl_rep <* QUERY (pdr <* USEDIN(pd,

```

```

        'INTEGRATED_CNC_SCHEMA.' +
        'PROPERTY_DEFINITION_REPRESENTATION.DEFINITION')| (
        'INTEGRATED_CNC_SCHEMA.' +
        'SHAPE_REPRESENTATION_WITH_PARAMETERS' IN TYPEOF(pdr.
        used_representation)))| NOT (SIZEOF(QUERY (it <* impl_rep.
        used_representation.items| (
        'INTEGRATED_CNC_SCHEMA.PLANE_ANGLE_MEASURE_WITH_UNIT' IN
        TYPEOF(it)) AND (it.name = 'offset')))) = 1))) = 0))) = 0);
WR9: NOT ('INTEGRATED_CNC_SCHEMA.RECTANGULAR_PATTERN' IN TYPEOF(SELF.
        relating_shape_aspect.of_shape.definition)) OR (SIZEOF(QUERY
        (pd <* USEDIN(SELF.related_shape_aspect,
        'INTEGRATED_CNC_SCHEMA.PROPERTY_DEFINITION.DEFINITION')| NOT
        (SIZEOF(QUERY (impl_rep <* QUERY (pdr <* USEDIN(pd,
        'INTEGRATED_CNC_SCHEMA.' +
        'PROPERTY_DEFINITION_REPRESENTATION.DEFINITION')| (
        'INTEGRATED_CNC_SCHEMA.' +
        'SHAPE_REPRESENTATION_WITH_PARAMETERS' IN TYPEOF(pdr.
        used_representation)))| NOT (SIZEOF(impl_rep.
        used_representation.items) = 3))) = 0))) = 0);
WR10: NOT ('INTEGRATED_CNC_SCHEMA.RECTANGULAR_PATTERN' IN TYPEOF(SELF.
        relating_shape_aspect.of_shape.definition)) OR (SIZEOF(QUERY
        (pd <* USEDIN(SELF.related_shape_aspect,
        'INTEGRATED_CNC_SCHEMA.PROPERTY_DEFINITION.DEFINITION')| NOT
        (SIZEOF(QUERY (impl_rep <* QUERY (pdr <* USEDIN(pd,
        'INTEGRATED_CNC_SCHEMA.' +
        'PROPERTY_DEFINITION_REPRESENTATION.DEFINITION')| (
        'INTEGRATED_CNC_SCHEMA.' +
        'SHAPE_REPRESENTATION_WITH_PARAMETERS' IN TYPEOF(pdr.
        used_representation)))| NOT (SIZEOF(QUERY (it <* impl_rep.
        used_representation.items| ((
        'INTEGRATED_CNC_SCHEMA.MEASURE_REPRESENTATION_ITEM' IN TYPEOF
        (it)) AND ('INTEGRATED_CNC_SCHEMA.COUNT_MEASURE' IN TYPEOF(it
        \measure_with_unit.value_component))) AND (it.name =
        'row index')))) = 1))) = 0))) = 0);
WR11: NOT ('INTEGRATED_CNC_SCHEMA.RECTANGULAR_PATTERN' IN TYPEOF(SELF.
        relating_shape_aspect.of_shape.definition)) OR (SIZEOF(QUERY
        (pd <* USEDIN(SELF.related_shape_aspect,
        'INTEGRATED_CNC_SCHEMA.PROPERTY_DEFINITION.DEFINITION')| NOT
        (SIZEOF(QUERY (impl_rep <* QUERY (pdr <* USEDIN(pd,
        'INTEGRATED_CNC_SCHEMA.' +
        'PROPERTY_DEFINITION_REPRESENTATION.DEFINITION')| (
        'INTEGRATED_CNC_SCHEMA.' +
        'SHAPE_REPRESENTATION_WITH_PARAMETERS' IN TYPEOF(pdr.
        used_representation)))| NOT (SIZEOF(QUERY (it <* impl_rep.
        used_representation.items| ((
        'INTEGRATED_CNC_SCHEMA.MEASURE_REPRESENTATION_ITEM' IN TYPEOF
        (it)) AND ('INTEGRATED_CNC_SCHEMA.COUNT_MEASURE' IN TYPEOF(it
        \measure_with_unit.value_component))) AND (it.name =
        'column index')))) = 1))) = 0))) = 0);
WR12: NOT ('INTEGRATED_CNC_SCHEMA.RECTANGULAR_PATTERN' IN TYPEOF(SELF.
        relating_shape_aspect.of_shape.definition)) OR (SIZEOF(QUERY
        (pd <* USEDIN(SELF.related_shape_aspect,
        'INTEGRATED_CNC_SCHEMA.PROPERTY_DEFINITION.DEFINITION')| NOT
        (SIZEOF(QUERY (impl_rep <* QUERY (pdr <* USEDIN(pd,

```

```

'INTEGRATED_CNC_SCHEMA.' +
'PROPERTY_DEFINITION_REPRESENTATION.DEFINITION')| (
'INTEGRATED_CNC_SCHEMA.' +
'SHAPE_REPRESENTATION_WITH_PARAMETERS' IN TYPEOF(pdr.
used_representation)))| NOT (SIZEOF(QUERY (it <* impl_rep.
used_representation.items| (
'INTEGRATED_CNC_SCHEMA.LENGTH_MEASURE_WITH_UNIT' IN TYPEOF(it
)) AND (it.name = 'offset distance')))) = 1))) = 0));
WR13: NOT ('INTEGRATED_CNC_SCHEMA.RECTANGULAR_PATTERN' IN TYPEOF(SELF.
relating_shape_aspect.of_shape.definition)) OR (SIZEOF(QUERY
(pd <* USEDIN(SELF.related_shape_aspect,
'INTEGRATED_CNC_SCHEMA.PROPERTY_DEFINITION.DEFINITION')| NOT
(SIZEOF(QUERY (pdr <* USEDIN(pd, 'INTEGRATED_CNC_SCHEMA.' +
'PROPERTY_DEFINITION_REPRESENTATION.DEFINITION')| (
'INTEGRATED_CNC_SCHEMA.DIRECTION_SHAPE_REPRESENTATION' IN
TYPEOF(pdr.used_representation)) AND (pdr.used_representation
.name = 'offset direction')))) = 1))) = 0);
END_ENTITY; -- 10303-522: aic_machining_feature

```

```

ENTITY pattern_omit_membership
  SUBTYPE OF (feature_component_relationship);
  WHERE
    WR1: SIZEOF(QUERY (fcr <* QUERY (sar <* USEDIN(SELF.
      relating_shape_aspect,
      'INTEGRATED_CNC_SCHEMA.SHAPE_ASPECT_RELATIONSHIP.' +
      'RELATING_SHAPE_ASPECT')| (
      'INTEGRATED_CNC_SCHEMA.FEATURE_COMPONENT_RELATIONSHIP' IN
      TYPEOF(sar)) AND (sar :<>: SELF))| (SIZEOF(QUERY (pdr <*
      QUERY (pd <* USEDIN(fcr.related_shape_aspect.of_shape,
      'INTEGRATED_CNC_SCHEMA.PROPERTY_DEFINITION.DEFINITION')| (
      'INTEGRATED_CNC_SCHEMA.PRODUCT_DEFINITION_SHAPE' IN TYPEOF(pd
      )))| (SIZEOF([ 'INTEGRATED_CNC_SCHEMA.CIRCULAR_PATTERN',
      'INTEGRATED_CNC_SCHEMA.RECTANGULAR_PATTERN' ] * TYPEOF(pdr.
      definition)) = 1))) = 0))) = 0;
    WR2: SIZEOF(QUERY (fcr <* QUERY (sar <* USEDIN(SELF.
      related_shape_aspect,
      'INTEGRATED_CNC_SCHEMA.SHAPE_ASPECT_RELATIONSHIP.' +
      'RELATED_SHAPE_ASPECT')| (
      'INTEGRATED_CNC_SCHEMA.FEATURE_COMPONENT_RELATIONSHIP' IN
      TYPEOF(sar)) AND (sar :<>: SELF))| (fcr.description =
      'modified pattern') AND (
      'INTEGRATED_CNC_SCHEMA.MODIFIED_PATTERN' IN TYPEOF(fcr.
      relating_shape_aspect)))) >= 1;
    WR3: SIZEOF(QUERY (fcr <* QUERY (sar <* USEDIN(SELF.
      related_shape_aspect,
      'INTEGRATED_CNC_SCHEMA.SHAPE_ASPECT_RELATIONSHIP.' +
      'RELATED_SHAPE_ASPECT')| (
      'INTEGRATED_CNC_SCHEMA.FEATURE_COMPONENT_RELATIONSHIP' IN
      TYPEOF(sar)) AND (sar :<>: SELF))| (
      'INTEGRATED_CNC_SCHEMA.MODIFIED_PATTERN' IN TYPEOF(fcr.
      relating_shape_aspect)) AND NOT (SIZEOF(QUERY (modfcr <*
      QUERY (modsar <* USEDIN(fcr.relying_shape_aspect,
      'INTEGRATED_CNC_SCHEMA.' +
      'SHAPE_ASPECT_RELATIONSHIP.RELATING_SHAPE_ASPECT')| (SIZEOF([

```

```

        'INTEGRATED_CNC_SCHEMA.CIRCULAR_PATTERN',
        'INTEGRATED_CNC_SCHEMA.RECTANGULAR_PATTERN' ] * TYPEOF(modsar
        .related_shape_aspect.of_shape.definition)) = 1) AND (modsar
        :<>: fcr))| NOT (modfcr.related_shape_aspect.of_shape.
        definition := SELF.relating_shape_aspect.of_shape.definition
        ))) = 0))) = 0;
WR4: SIZEOF(QUERY (pd <* USEDIN(SELF.related_shape_aspect,
        'INTEGRATED_CNC_SCHEMA.PROPERTY_DEFINITION.DEFINITION')| NOT
        (SIZEOF(USEDIN(pd, 'INTEGRATED_CNC_SCHEMA.' +
        'PROPERTY_DEFINITION_REPRESENTATION.DEFINITION')) = 1))) = 0;
WR5: NOT ('INTEGRATED_CNC_SCHEMA.CIRCULAR_PATTERN' IN TYPEOF(SELF.
        relating_shape_aspect.of_shape.definition)) OR (SIZEOF(QUERY
        (pd <* USEDIN(SELF.related_shape_aspect,
        'INTEGRATED_CNC_SCHEMA.PROPERTY_DEFINITION.DEFINITION')| NOT
        (SIZEOF(QUERY (pdr <* USEDIN(pd, 'INTEGRATED_CNC_SCHEMA.' +
        'PROPERTY_DEFINITION_REPRESENTATION.DEFINITION')| NOT (SIZEOF
        (pdr.used_representation.items) = 1)))) = 0))) = 0);
WR6: NOT ('INTEGRATED_CNC_SCHEMA.CIRCULAR_PATTERN' IN TYPEOF(SELF.
        relating_shape_aspect.of_shape.definition)) OR (SIZEOF(QUERY
        (pd <* USEDIN(SELF.related_shape_aspect,
        'INTEGRATED_CNC_SCHEMA.PROPERTY_DEFINITION.DEFINITION')| NOT
        (SIZEOF(QUERY (impl_rep <* QUERY (pdr <* USEDIN(pd,
        'INTEGRATED_CNC_SCHEMA.' +
        'PROPERTY_DEFINITION_REPRESENTATION.DEFINITION')| (
        'INTEGRATED_CNC_SCHEMA.' +
        'SHAPE_REPRESENTATION_WITH_PARAMETERS' IN TYPEOF(pdr.
        used_representation)))| NOT (SIZEOF(QUERY (it <* impl_rep.
        used_representation.items| ((
        'INTEGRATED_CNC_SCHEMA.MEASURE_REPRESENTATION_ITEM' IN TYPEOF
        (it)) AND ('INTEGRATED_CNC_SCHEMA.COUNT_MEASURE' IN TYPEOF(it
        \measure_with_unit.value_component))) AND (it.name =
        'index number')))) = 1)))) = 0))) = 0);
WR7: NOT ('INTEGRATED_CNC_SCHEMA.RECTANGULAR_PATTERN' IN TYPEOF(SELF.
        relating_shape_aspect.of_shape.definition)) OR (SIZEOF(QUERY
        (pd <* USEDIN(SELF.related_shape_aspect,
        'INTEGRATED_CNC_SCHEMA.PROPERTY_DEFINITION.DEFINITION')| NOT
        (SIZEOF(QUERY (pdr <* USEDIN(pd, 'INTEGRATED_CNC_SCHEMA.' +
        'PROPERTY_DEFINITION_REPRESENTATION.DEFINITION')| NOT (SIZEOF
        (pdr.used_representation.items) = 2)))) = 0))) = 0);
WR8: NOT ('INTEGRATED_CNC_SCHEMA.RECTANGULAR_PATTERN' IN TYPEOF(SELF.
        relating_shape_aspect.of_shape.definition)) OR (SIZEOF(QUERY
        (pd <* USEDIN(SELF.related_shape_aspect,
        'INTEGRATED_CNC_SCHEMA.PROPERTY_DEFINITION.DEFINITION')| NOT
        (SIZEOF(QUERY (impl_rep <* QUERY (pdr <* USEDIN(pd,
        'INTEGRATED_CNC_SCHEMA.' +
        'PROPERTY_DEFINITION_REPRESENTATION.DEFINITION')| (
        'INTEGRATED_CNC_SCHEMA.' +
        'SHAPE_REPRESENTATION_WITH_PARAMETERS' IN TYPEOF(pdr.
        used_representation)))| NOT (SIZEOF(QUERY (it <* impl_rep.
        used_representation.items| ((
        'INTEGRATED_CNC_SCHEMA.MEASURE_REPRESENTATION_ITEM' IN TYPEOF
        (it)) AND ('INTEGRATED_CNC_SCHEMA.COUNT_MEASURE' IN TYPEOF(it
        \measure_with_unit.value_component))) AND (it.name =
        'row index')))) = 1)))) = 0))) = 0);

```

```

WR9: NOT ('INTEGRATED_CNC_SCHEMA.RECTANGULAR_PATTERN' IN TYPEOF(SELF.
relating_shape_aspect.of_shape.definition)) OR (SIZEOF(QUERY
(pd <* USEDIN(SELF.related_shape_aspect,
'INTEGRATED_CNC_SCHEMA.PROPERTY_DEFINITION.DEFINITION') | NOT
(SIZEOF(QUERY (impl_rep <* QUERY (pdr <* USEDIN(pd,
'INTEGRATED_CNC_SCHEMA.' +
'PROPERTY_DEFINITION_REPRESENTATION.DEFINITION') | (
'INTEGRATED_CNC_SCHEMA.' +
'SHAPE_REPRESENTATION_WITH_PARAMETERS' IN TYPEOF(pdr.
used_representation))) | NOT (SIZEOF(QUERY (it <* impl_rep.
used_representation.items | ((
'INTEGRATED_CNC_SCHEMA.MEASURE_REPRESENTATION_ITEM' IN TYPEOF
(it)) AND ('INTEGRATED_CNC_SCHEMA.COUNT_MEASURE' IN TYPEOF(it
\measure_with_unit.value_component))) AND (it.name =
'column index')))) = 1))) = 0))) = 0);
END_ENTITY; -- 10303-522: aic_machining_feature

```

```

ENTITY pcurve
  SUBTYPE OF (curve);
  basis_surface      : surface;
  reference_to_curve : definitional_representation;
  WHERE
    WR1: SIZEOF(reference_to_curve\representation.items) = 1;
    WR2: 'INTEGRATED_CNC_SCHEMA.CURVE' IN TYPEOF(reference_to_curve\
representation.items[1]);
    WR3: reference_to_curve\representation.items[1]\
geometric_representation_item.dim = 2;
END_ENTITY; -- 10303-42: geometry_schema

```

```

ENTITY perpendicular_to
  SUBTYPE OF (derived_shape_aspect);
  WHERE
    WR1: SIZEOF(SELF\derived_shape_aspect.deriving_relationships) = 1;
END_ENTITY; -- 10303-47: shape_aspect_definition_schema

```

```

ENTITY perpendicularity_tolerance
  SUBTYPE OF (geometric_tolerance_with_datum_reference);
  WHERE
    WR1: SIZEOF(SELF\geometric_tolerance_with_datum_reference.datum_system)
<= 3;
END_ENTITY; -- 10303-519: aic_geometric_tolerances

```

```

ENTITY person;
  id          : identifier;
  last_name   : OPTIONAL label;
  first_name  : OPTIONAL label;
  middle_names : OPTIONAL LIST [1:?] OF label;
  prefix_titles : OPTIONAL LIST [1:?] OF label;
  suffix_titles : OPTIONAL LIST [1:?] OF label;
  WHERE
    WR1: EXISTS(last_name) OR EXISTS(first_name);
END_ENTITY; -- 10303-41: person_organization_schema

```

```

ENTITY person_and_organization;

```

ISO 10303-238:2007(E)

```

    the_person      : person;
    the_organization : organization;
DERIVE
    name           : label := get_name_value(SELF);
    description    : text := get_description_value(SELF);
WHERE
    WR1: SIZEOF(USEDIN(SELF, 'INTEGRATED_CNC_SCHEMA.' +
        'NAME_ATTRIBUTE.NAMED_ITEM')) <= 1;
    WR2: SIZEOF(USEDIN(SELF, 'INTEGRATED_CNC_SCHEMA.' +
        'DESCRIPTION_ATTRIBUTE.DESCRIBED_ITEM')) <= 1;
END_ENTITY; -- 10303-41: person_organization_schema

ENTITY person_and_organization_assignment
    ABSTRACT SUPERTYPE;
    assigned_person_and_organization : person_and_organization;
    role                             : person_and_organization_role;
END_ENTITY; -- 10303-41: management_resources_schema

ENTITY person_and_organization_role;
    name : label;
DERIVE
    description : text := get_description_value(SELF);
WHERE
    WR1: SIZEOF(USEDIN(SELF, 'INTEGRATED_CNC_SCHEMA.' +
        'DESCRIPTION_ATTRIBUTE.DESCRIBED_ITEM')) <= 1;
END_ENTITY; -- 10303-41: person_organization_schema

ENTITY personal_address
    SUBTYPE OF (address);
    people      : SET [1:?] OF person;
    description : OPTIONAL text;
END_ENTITY; -- 10303-41: person_organization_schema

ENTITY placed_datum_target_feature
    SUBTYPE OF (datum_target);
WHERE
    WR1: SELF.description IN [ 'point', 'line', 'rectangle', 'circle' ];
    WR2: SIZEOF(QUERY (pd <* USEDIN(SELF,
        'INTEGRATED_CNC_SCHEMA.PROPERTY_DEFINITION.DEFINITION') | NOT
        (SIZEOF(QUERY (pdr <* USEDIN(pd, 'INTEGRATED_CNC_SCHEMA.' +
        'PROPERTY_DEFINITION_REPRESENTATION.DEFINITION') | (
        'INTEGRATED_CNC_SCHEMA.' +
        'SHAPE_REPRESENTATION_WITH_PARAMETERS' IN TYPEOF(pdr.
        used_representation)))) = 1))) = 0;
    WR3: SIZEOF(QUERY (pd <* USEDIN(SELF,
        'INTEGRATED_CNC_SCHEMA.PROPERTY_DEFINITION.DEFINITION') | NOT
        (SIZEOF(QUERY (dtm_rep <* QUERY (pdr <* USEDIN(pd,
        'INTEGRATED_CNC_SCHEMA.' +
        'PROPERTY_DEFINITION_REPRESENTATION.DEFINITION') | (
        'INTEGRATED_CNC_SCHEMA.' +
        'SHAPE_REPRESENTATION_WITH_PARAMETERS' IN TYPEOF(pdr.
        used_representation))) | NOT (SIZEOF(QUERY (it <* dtm_rep.
        used_representation.items | ('INTEGRATED_CNC_SCHEMA.PLACEMENT'
        IN TYPEOF(it)) AND (it.name = 'orientation')) = 1))) = 0)))

```



```

= 0;
WR4: NOT (SELF.description = 'point') OR (SIZEOF(QUERY (pd <* USEDIN(
  SELF, 'INTEGRATED_CNC_SCHEMA.PROPERTY_DEFINITION.DEFINITION')
  | NOT (SIZEOF(QUERY (dtm_rep <* QUERY (pdr <* USEDIN(pd,
  'INTEGRATED_CNC_SCHEMA.' +
  'PROPERTY_DEFINITION_REPRESENTATION.DEFINITION') | (
  'INTEGRATED_CNC_SCHEMA.' +
  'SHAPE_REPRESENTATION_WITH_PARAMETERS' IN TYPEOF(pdr.
  used_representation))) | NOT (SIZEOF(dtm_rep.
  used_representation.items) = 1))) = 0))) = 0);
WR5: NOT (SELF.description IN [ 'line', 'circle' ]) OR (SIZEOF(QUERY (
  pd <* USEDIN(SELF,
  'INTEGRATED_CNC_SCHEMA.PROPERTY_DEFINITION.DEFINITION') | NOT
  (SIZEOF(QUERY (dtm_rep <* QUERY (pdr <* USEDIN(pd,
  'INTEGRATED_CNC_SCHEMA.' +
  'PROPERTY_DEFINITION_REPRESENTATION.DEFINITION') | (
  'INTEGRATED_CNC_SCHEMA.' +
  'SHAPE_REPRESENTATION_WITH_PARAMETERS' IN TYPEOF(pdr.
  used_representation))) | NOT (SIZEOF(dtm_rep.
  used_representation.items) = 2))) = 0))) = 0);
WR6: NOT (SELF.description = 'rectangle') OR (SIZEOF(QUERY (pd <*
  USEDIN(SELF,
  'INTEGRATED_CNC_SCHEMA.PROPERTY_DEFINITION.DEFINITION') | NOT
  (SIZEOF(QUERY (dtm_rep <* QUERY (pdr <* USEDIN(pd,
  'INTEGRATED_CNC_SCHEMA.' +
  'PROPERTY_DEFINITION_REPRESENTATION.DEFINITION') | (
  'INTEGRATED_CNC_SCHEMA.' +
  'SHAPE_REPRESENTATION_WITH_PARAMETERS' IN TYPEOF(pdr.
  used_representation))) | NOT (SIZEOF(dtm_rep.
  used_representation.items) = 3))) = 0))) = 0);
WR7: NOT (SELF.description = 'circle') OR (SIZEOF(QUERY (pd <* USEDIN(
  SELF, 'INTEGRATED_CNC_SCHEMA.PROPERTY_DEFINITION.DEFINITION')
  | NOT (SIZEOF(QUERY (dtm_rep <* QUERY (pdr <* USEDIN(pd,
  'INTEGRATED_CNC_SCHEMA.' +
  'PROPERTY_DEFINITION_REPRESENTATION.DEFINITION') | (
  'INTEGRATED_CNC_SCHEMA.' +
  'SHAPE_REPRESENTATION_WITH_PARAMETERS' IN TYPEOF(pdr.
  used_representation))) | NOT (SIZEOF(QUERY (it <* dtm_rep.
  used_representation.items | (SIZEOF([
  'INTEGRATED_CNC_SCHEMA.MEASURE_REPRESENTATION_ITEM',
  'INTEGRATED_CNC_SCHEMA.LENGTH_MEASURE_WITH_UNIT' ] * TYPEOF(
  it)) = 2) AND (it.name = 'target diameter')) = 1))) = 0))) =
  0);
WR8: NOT (SELF.description = 'line') OR (SIZEOF(QUERY (pd <* USEDIN(
  SELF, 'INTEGRATED_CNC_SCHEMA.PROPERTY_DEFINITION.DEFINITION')
  | NOT (SIZEOF(QUERY (dtm_rep <* QUERY (pdr <* USEDIN(pd,
  'INTEGRATED_CNC_SCHEMA.' +
  'PROPERTY_DEFINITION_REPRESENTATION.DEFINITION') | (
  'INTEGRATED_CNC_SCHEMA.' +
  'SHAPE_REPRESENTATION_WITH_PARAMETERS' IN TYPEOF(pdr.
  used_representation))) | NOT (SIZEOF(QUERY (it <* dtm_rep.
  used_representation.items | (SIZEOF([
  'INTEGRATED_CNC_SCHEMA.MEASURE_REPRESENTATION_ITEM',
  'INTEGRATED_CNC_SCHEMA.LENGTH_MEASURE_WITH_UNIT' ] * TYPEOF(

```

```

        it)) = 2) AND (it.name = 'target length')) = 1))) = 0))) = 0
    );
WR9: NOT (SELF.description = 'rectangle') OR (SIZEOF(QUERY (pd <*
    USEDIN(SELF,
    'INTEGRATED_CNC_SCHEMA.PROPERTY_DEFINITION.DEFINITION') | NOT
    (SIZEOF(QUERY (dtm_rep <* QUERY (pdr <* USEDIN(pd,
    'INTEGRATED_CNC_SCHEMA.' +
    'PROPERTY_DEFINITION_REPRESENTATION.DEFINITION') | (
    'INTEGRATED_CNC_SCHEMA.' +
    'SHAPE_REPRESENTATION_WITH_PARAMETERS' IN TYPEOF(pdr.
    used_representation))) | NOT (SIZEOF(QUERY (it <* dtm_rep.
    used_representation.items | (SIZEOF([
    'INTEGRATED_CNC_SCHEMA.MEASURE_REPRESENTATION_ITEM',
    'INTEGRATED_CNC_SCHEMA.LENGTH_MEASURE_WITH_UNIT' ] * TYPEOF(
    it)) = 2) AND (it.name = 'target length')) = 1))) = 0))) = 0
    );
WR10: NOT (SELF.description = 'rectangle') OR (SIZEOF(QUERY (pd <*
    USEDIN(SELF,
    'INTEGRATED_CNC_SCHEMA.PROPERTY_DEFINITION.DEFINITION') | NOT
    (SIZEOF(QUERY (dtm_rep <* QUERY (pdr <* USEDIN(pd,
    'INTEGRATED_CNC_SCHEMA.' +
    'PROPERTY_DEFINITION_REPRESENTATION.DEFINITION') | (
    'INTEGRATED_CNC_SCHEMA.' +
    'SHAPE_REPRESENTATION_WITH_PARAMETERS' IN TYPEOF(pdr.
    used_representation))) | NOT (SIZEOF(QUERY (it <* dtm_rep.
    used_representation.items | (SIZEOF([
    'INTEGRATED_CNC_SCHEMA.MEASURE_REPRESENTATION_ITEM',
    'INTEGRATED_CNC_SCHEMA.LENGTH_MEASURE_WITH_UNIT' ] * TYPEOF(
    it)) = 2) AND (it.name = 'target width')) = 1))) = 0))) = 0
    ;
END_ENTITY; -- 10303-238: integrated_cnc_schema

ENTITY placement
    SUPERTYPE OF (ONEOF(axis1_placement, axis2_placement_2d,
        axis2_placement_3d))
    SUBTYPE OF (geometric_representation_item);
    location : cartesian_point;
END_ENTITY; -- 10303-42: geometry_schema

ENTITY planar_shape_representation
    SUBTYPE OF (shape_representation);
    WHERE
        WR1: SIZEOF(SELF.items) = 1;
        WR2: SIZEOF(QUERY (it <* SELF.items | ('INTEGRATED_CNC_SCHEMA.PLANE' IN
            TYPEOF(it)))) = 1;
END_ENTITY; -- 10303-522: aic_machining_feature

ENTITY plane
    SUBTYPE OF (elementary_surface);
END_ENTITY; -- 10303-42: geometry_schema

ENTITY plane_angle_measure_with_unit
    SUBTYPE OF (measure_with_unit);
    WHERE

```

```

        WR1: 'INTEGRATED_CNC_SCHEMA.PLANE_ANGLE_UNIT' IN TYPEOF(SELF\
            measure_with_unit.unit_component);
END_ENTITY; -- 10303-41: measure_schema

ENTITY plane_angle_unit
    SUBTYPE OF (named_unit);
    WHERE
        WR1: (((((SELF\named_unit.dimensions.length_exponent = 0.0) AND (SELF\
            named_unit.dimensions.mass_exponent = 0.0)) AND (SELF\
            named_unit.dimensions.time_exponent = 0.0)) AND (SELF\
            named_unit.dimensions.electric_current_exponent = 0.0)) AND (
            SELF\named_unit.dimensions.thermodynamic_temperature_exponent
            = 0.0)) AND (SELF\named_unit.dimensions.
            amount_of_substance_exponent = 0.0)) AND (SELF\named_unit.
            dimensions.luminous_intensity_exponent = 0.0);
END_ENTITY; -- 10303-41: measure_schema

ENTITY plane_milling_operation
    SUBTYPE OF (milling_type_operation);
    WHERE
        WR1: (SELF.description IN ['roughing','finishing']);

        WR2: (verify_optional_action_property      (SELF, 'axial cutting depth'))
AND
        (verify_length_measure_action_property    (SELF, 'axial cutting depth'));

        WR3: (verify_optional_action_property      (SELF, 'allowance bottom')) AND
        (verify_length_measure_action_property    (SELF, 'allowance bottom'));

        WR4: NOT (SELF.description = 'roughing') OR
        (verify_required_action_property (SELF, 'allowance bottom'));
END_ENTITY; -- 10303-238: integrated_cnc_schema

ENTITY plus_minus_tolerance;
    range          : tolerance_method_definition;
    toleranced_dimension : dimensional_characteristic;
    UNIQUE
        UR1: toleranced_dimension;
END_ENTITY; -- 10303-47: shape_tolerance_schema

ENTITY pocket
    SUBTYPE OF (feature_definition);
    WHERE
        WR1: SELF\characterized_object.description IN [ 'closed rectangular',
            'open rectangular', 'complex', 'circular cutout',
            'complex cutout', 'recess' ];
        WR2: SIZEOF(QUERY (pds <* QUERY (pd <* USEDIN(SELF,
            'INTEGRATED_CNC_SCHEMA.PROPERTY_DEFINITION.DEFINITION') | (
            'INTEGRATED_CNC_SCHEMA.PRODUCT_DEFINITION_SHAPE' IN TYPEOF(pd
            ))) | NOT (SIZEOF(QUERY (sa_occ <* USEDIN(pds,
            'INTEGRATED_CNC_SCHEMA.SHAPE_ASPECT.OF_SHAPE') | (sa_occ.
            description = 'pocket depth occurrence') AND (SIZEOF(QUERY (
            sdr <* QUERY (sar <* USEDIN(sa_occ,
            'INTEGRATED_CNC_SCHEMA.SHAPE_ASPECT_RELATIONSHIP.' +

```

```

'RELATED_SHAPE_ASPECT')| ((sar.description =
'path feature component usage') AND (sar.name =
'pocket depth')) AND (
'INTEGRATED_CNC_SCHEMA.SHAPE_DEFINING_RELATIONSHIP' IN TYPEOF
(sar)))| ('INTEGRATED_CNC_SCHEMA.PATH_FEATURE_COMPONENT' IN
TYPEOF(sdr.relating_shape_aspect)) AND (sdr.
relating_shape_aspect.description = 'linear')) = 1))) = 1)))
= 0;
WR3: SIZEOF(QUERY (pdr <* get_property_definition_representations(SELF
| (
'INTEGRATED_CNC_SCHEMA.SHAPE_REPRESENTATION_WITH_PARAMETERS'
IN TYPEOF(pdr.used_representation)))) = 1;
WR4: SIZEOF(QUERY (pd <* USEDIN(SELF,
'INTEGRATED_CNC_SCHEMA.PROPERTY_DEFINITION.DEFINITION')| (
SIZEOF(QUERY (pdr <* USEDIN(pd, 'INTEGRATED_CNC_SCHEMA.' +
'PROPERTY_DEFINITION_REPRESENTATION.DEFINITION')| (
'INTEGRATED_CNC_SCHEMA.' +
'SHAPE_REPRESENTATION_WITH_PARAMETERS' IN TYPEOF(pdr.
used_representation)) AND ((1 <= SIZEOF(pdr.
used_representation.items)) AND (SIZEOF(pdr.
used_representation.items) <= 2)))) = 1))) = 1;
WR5: SIZEOF(QUERY (pd <* USEDIN(SELF,
'INTEGRATED_CNC_SCHEMA.PROPERTY_DEFINITION.DEFINITION')| (
SIZEOF(QUERY (pdr <* USEDIN(pd, 'INTEGRATED_CNC_SCHEMA.' +
'PROPERTY_DEFINITION_REPRESENTATION.DEFINITION')| (
'INTEGRATED_CNC_SCHEMA.' +
'SHAPE_REPRESENTATION_WITH_PARAMETERS' IN TYPEOF(pdr.
used_representation)) AND (SIZEOF(QUERY (srwp_i <* pdr.
used_representation.items| (srwp_i.name = 'orientation') OR (
srwp_i.name = 'fillet radius')) = SIZEOF(pdr.
used_representation.items)))) = 1))) = 1;
WR6: SIZEOF(QUERY (pd <* USEDIN(SELF,
'INTEGRATED_CNC_SCHEMA.PROPERTY_DEFINITION.DEFINITION')| NOT
(SIZEOF(QUERY (impl_rep <* QUERY (pdr <* USEDIN(pd,
'INTEGRATED_CNC_SCHEMA.' +
'PROPERTY_DEFINITION_REPRESENTATION.DEFINITION')| (
'INTEGRATED_CNC_SCHEMA.' +
'SHAPE_REPRESENTATION_WITH_PARAMETERS' IN TYPEOF(pdr.
used_representation))))| NOT (SIZEOF(QUERY (it <* impl_rep.
used_representation.items| (SIZEOF([
'INTEGRATED_CNC_SCHEMA.MEASURE_REPRESENTATION_ITEM',
'INTEGRATED_CNC_SCHEMA.LENGTH_MEASURE_WITH_UNIT' ] * TYPEOF(
it)) = 2) AND (it.name = 'fillet radius')) <= 1))) = 0))) =
0;
WR7: NOT (SELF\characterized_object.description IN [ 'complex',
'non-circular cutout', 'recess' ]) OR (SIZEOF(QUERY (pds <*
QUERY (pd <* USEDIN(SELF,
'INTEGRATED_CNC_SCHEMA.PROPERTY_DEFINITION.DEFINITION')| (
'INTEGRATED_CNC_SCHEMA.PRODUCT_DEFINITION_SHAPE' IN TYPEOF(pd
)))| NOT (SIZEOF(QUERY (sa_occ <* USEDIN(pds,
'INTEGRATED_CNC_SCHEMA.SHAPE_ASPECT.OF_SHAPE')| (sa_occ.
description = 'boundary occurrence') AND (SIZEOF(QUERY (sdr
<* QUERY (sar <* USEDIN(sa_occ,
'INTEGRATED_CNC_SCHEMA.SHAPE_ASPECT_RELATIONSHIP.' +

```

```

'RELATED_SHAPE_ASPECT')| (sar.description = 'profile usage')
AND ('INTEGRATED_CNC_SCHEMA.SHAPE_DEFINING_RELATIONSHIP' IN
TYPEOF(sar)))| (SIZEOF([
'INTEGRATED_CNC_SCHEMA.CIRCULAR_CLOSED_PROFILE',
'INTEGRATED_CNC_SCHEMA.NGON_CLOSED_PROFILE',
'INTEGRATED_CNC_SCHEMA.RECTANGULAR_CLOSED_PROFILE',
'INTEGRATED_CNC_SCHEMA.CLOSED_PATH_PROFILE',
'INTEGRATED_CNC_SCHEMA.SQUARE_U_PROFILE',
'INTEGRATED_CNC_SCHEMA.PARTIAL_CIRCULAR_PROFILE',
'INTEGRATED_CNC_SCHEMA.ROUNDED_U_PROFILE',
'INTEGRATED_CNC_SCHEMA.VEE_PROFILE',
'INTEGRATED_CNC_SCHEMA.TEE_PROFILE',
'INTEGRATED_CNC_SCHEMA.OPEN_PATH_PROFILE' ] * TYPEOF(sdr.
relating_shape_aspect)) = 1))) = 1))) = 0);
WR8: NOT (SELF\characterized_object.description = 'closed rectangular')
OR (SIZEOF(QUERY (pds <* QUERY (pd <* USEDIN(SELF,
'INTEGRATED_CNC_SCHEMA.PROPERTY_DEFINITION.DEFINITION')| (
'INTEGRATED_CNC_SCHEMA.PRODUCT_DEFINITION_SHAPE' IN TYPEOF(pd
)))| NOT (SIZEOF(QUERY (sa_occ <* USEDIN(pds,
'INTEGRATED_CNC_SCHEMA.SHAPE_ASPECT.OF_SHAPE')| (sa_occ.
description = 'closed boundary occurrence') AND (SIZEOF(QUERY
(sdr <* QUERY (sar <* USEDIN(sa_occ,
'INTEGRATED_CNC_SCHEMA.SHAPE_ASPECT_RELATIONSHIP.' +
'RELATED_SHAPE_ASPECT')| (sar.description = 'profile usage')
AND ('INTEGRATED_CNC_SCHEMA.SHAPE_DEFINING_RELATIONSHIP' IN
TYPEOF(sar)))| (
'INTEGRATED_CNC_SCHEMA.RECTANGULAR_CLOSED_PROFILE' IN TYPEOF(
sdr.relying_shape_aspect)))) = 1))) = 1))) = 0);
WR9: NOT (SELF\characterized_object.description = 'open rectangular')
OR (SIZEOF(QUERY (pds <* QUERY (pd <* USEDIN(SELF,
'INTEGRATED_CNC_SCHEMA.PROPERTY_DEFINITION.DEFINITION')| (
'INTEGRATED_CNC_SCHEMA.PRODUCT_DEFINITION_SHAPE' IN TYPEOF(pd
)))| NOT (SIZEOF(QUERY (sa_occ <* USEDIN(pds,
'INTEGRATED_CNC_SCHEMA.SHAPE_ASPECT.OF_SHAPE')| (sa_occ.
description = 'open boundary occurrence') AND (SIZEOF(QUERY (
sdr <* QUERY (sar <* USEDIN(sa_occ,
'INTEGRATED_CNC_SCHEMA.SHAPE_ASPECT_RELATIONSHIP.' +
'RELATED_SHAPE_ASPECT')| (sar.description = 'profile usage')
AND ('INTEGRATED_CNC_SCHEMA.SHAPE_DEFINING_RELATIONSHIP' IN
TYPEOF(sar)))| ('INTEGRATED_CNC_SCHEMA.SQUARE_U_PROFILE' IN
TYPEOF(sdr.relying_shape_aspect)))) = 1))) = 1))) = 0);
WR10: SIZEOF(QUERY (pds <* QUERY (pd <* USEDIN(SELF,
'INTEGRATED_CNC_SCHEMA.PROPERTY_DEFINITION.DEFINITION')| (
'INTEGRATED_CNC_SCHEMA.PRODUCT_DEFINITION_SHAPE' IN TYPEOF(pd
)))| NOT (SIZEOF(QUERY (sa_occ <* USEDIN(pds,
'INTEGRATED_CNC_SCHEMA.SHAPE_ASPECT.OF_SHAPE')| (sa_occ.
description = 'bottom condition occurrence') AND (SIZEOF(
QUERY (sdr <* QUERY (sar <* USEDIN(sa_occ,
'INTEGRATED_CNC_SCHEMA.SHAPE_ASPECT_RELATIONSHIP.' +
'RELATED_SHAPE_ASPECT')| (sar.description =
'pocket bottom usage') AND (
'INTEGRATED_CNC_SCHEMA.FEATURE_COMPONENT_RELATIONSHIP' IN
TYPEOF(sar)))| ('INTEGRATED_CNC_SCHEMA.POCKET_BOTTOM' IN
TYPEOF(sdr.relying_shape_aspect)) AND (

```

```

        'INTEGRATED_CNC_SCHEMA.POCKET' IN TYPEOF(sdr.
        related_shape_aspect.of_shape.definition)))) = 1))) = 1))) =
0;
WR11: NOT (SELF\characterized_object.description IN [ 'complex',
'non-circular cutout', 'recess' ]) OR (SIZEOF(QUERY (pds <*
QUERY (pd <* USEDIN(SELF,
'INTEGRATED_CNC_SCHEMA.PROPERTY_DEFINITION.DEFINITION')| (
'INTEGRATED_CNC_SCHEMA.PRODUCT_DEFINITION_SHAPE' IN TYPEOF(pd
)))| NOT (SIZEOF(QUERY (sa_occ <* USEDIN(pds,
'INTEGRATED_CNC_SCHEMA.SHAPE_ASPECT.OF_SHAPE')| (sa_occ.
description = 'change in boundary occurrence') AND (SIZEOF(
QUERY (fcr <* QUERY (sar <* USEDIN(sa_occ,
'INTEGRATED_CNC_SCHEMA.SHAPE_ASPECT_RELATIONSHIP.' +
'RELATING_SHAPE_ASPECT')| (sar.description = 'taper usage')
AND ('INTEGRATED_CNC_SCHEMA.FEATURE_COMPONENT_RELATIONSHIP'
IN TYPEOF(sar)))| (('INTEGRATED_CNC_SCHEMA.TAPER' IN TYPEOF(
fcr.relating_shape_aspect)) AND (
'INTEGRATED_CNC_SCHEMA.POCKET' IN TYPEOF(fcr.
related_shape_aspect.of_shape.definition))) AND (fcr.
related_shape_aspect.description IN [ 'angle taper',
'directed taper' ]))) = 1))) <= 1))) = 0);
WR12: NOT (SELF\characterized_object.description = 'circular cutout')
OR (SIZEOF(QUERY (pds <* QUERY (pd <* USEDIN(SELF,
'INTEGRATED_CNC_SCHEMA.PROPERTY_DEFINITION.DEFINITION')| (
'INTEGRATED_CNC_SCHEMA.PRODUCT_DEFINITION_SHAPE' IN TYPEOF(pd
)))| NOT (SIZEOF(QUERY (sa_occ <* USEDIN(pds,
'INTEGRATED_CNC_SCHEMA.SHAPE_ASPECT.OF_SHAPE')| (sa_occ.
description = 'enclosed boundary occurrence') AND (SIZEOF(
QUERY (sdr <* QUERY (sar <* USEDIN(sa_occ,
'INTEGRATED_CNC_SCHEMA.SHAPE_ASPECT_RELATIONSHIP.' +
'RELATED_SHAPE_ASPECT')| (sar.description = 'profile usage')
AND ('INTEGRATED_CNC_SCHEMA.SHAPE_DEFINING_RELATIONSHIP' IN
TYPEOF(sar)))| (
'INTEGRATED_CNC_SCHEMA.CIRCULAR_CLOSED_PROFILE' IN TYPEOF(sdr.
relating_shape_aspect)))) = 1))) = 1))) = 0);
WR13: NOT (SELF\characterized_object.description IN [ 'circular cutout'
, 'complex cutout' ]) OR (SIZEOF(QUERY (pds <* QUERY (pd <*
USEDIN(SELF,
'INTEGRATED_CNC_SCHEMA.PROPERTY_DEFINITION.DEFINITION')| (
'INTEGRATED_CNC_SCHEMA.PRODUCT_DEFINITION_SHAPE' IN TYPEOF(pd
)))| NOT (SIZEOF(QUERY (sa_occ <* USEDIN(pds,
'INTEGRATED_CNC_SCHEMA.SHAPE_ASPECT.OF_SHAPE')| (sa_occ.
description = 'bottom condition occurrence') AND (SIZEOF(
QUERY (sdr <* QUERY (sar <* USEDIN(sa_occ,
'INTEGRATED_CNC_SCHEMA.SHAPE_ASPECT_RELATIONSHIP.' +
'RELATED_SHAPE_ASPECT')| (sar.description =
'pocket bottom usage') AND (
'INTEGRATED_CNC_SCHEMA.FEATURE_COMPONENT_RELATIONSHIP' IN
TYPEOF(sar)))| (('INTEGRATED_CNC_SCHEMA.POCKET_BOTTOM' IN
TYPEOF(sdr.relating_shape_aspect)) AND (
'INTEGRATED_CNC_SCHEMA.POCKET' IN TYPEOF(sdr.
related_shape_aspect.of_shape.definition))) AND (sdr.
relating_shape_aspect.description = 'through')) = 1))) = 1))
) = 0);

```

```

WR14: NOT (SELF\characterized_object.description = 'recess') OR (SIZEOF(
  QUERY (pds <* QUERY (pd <* USEDIN(SELF,
    'INTEGRATED_CNC_SCHEMA.PROPERTY_DEFINITION.DEFINITION')| (
    'INTEGRATED_CNC_SCHEMA.PRODUCT_DEFINITION_SHAPE' IN TYPEOF(pd
  )))| NOT (SIZEOF(QUERY (sa_occ <* USEDIN(pds,
    'INTEGRATED_CNC_SCHEMA.SHAPE_ASPECT.OF_SHAPE')| (sa_occ.
    description = 'bottom condition occurrence') AND (SIZEOF(
    QUERY (sdr <* QUERY (sar <* USEDIN(sa_occ,
    'INTEGRATED_CNC_SCHEMA.SHAPE_ASPECT_RELATIONSHIP.' +
    'RELATED_SHAPE_ASPECT')| (sar.description =
    'pocket bottom usage') AND (
    'INTEGRATED_CNC_SCHEMA.FEATURE_COMPONENT_RELATIONSHIP' IN
    TYPEOF(sar)))| (('INTEGRATED_CNC_SCHEMA.POCKET_BOTTOM' IN
    TYPEOF(sdr.relying_shape_aspect)) AND (
    'INTEGRATED_CNC_SCHEMA.POCKET' IN TYPEOF(sdr.
    related_shape_aspect.of_shape.definition))) AND (sdr.
    relating_shape_aspect.description IN [ 'planar', 'complex' ]
  ))) = 1))) = 1))) = 0);

WR15: SIZEOF(QUERY (pdr <* get_property_definition_representations(SELF
  )| ('INTEGRATED_CNC_SCHEMA.PLANAR_SHAPE_REPRESENTATION' IN
  TYPEOF(pdr.used_representation)) AND (pdr.used_representation
  .name = 'maximum feature limit')) >= 0);

WR16: NOT (SELF\characterized_object.description IN [
  'closed rectangular', 'open rectangular', 'complex', 'recess'
  ]) OR (SIZEOF(QUERY (pds <* USEDIN(SELF,
    'INTEGRATED_CNC_SCHEMA.PROPERTY_DEFINITION.DEFINITION')| (
    'INTEGRATED_CNC_SCHEMA.PRODUCT_DEFINITION_SHAPE' IN TYPEOF(
    pds)) AND (SIZEOF(QUERY (csa <* USEDIN(pds,
    'INTEGRATED_CNC_SCHEMA.SHAPE_ASPECT.OF_SHAPE')| ((
    'INTEGRATED_CNC_SCHEMA.COMPOSITE_SHAPE_ASPECT' IN TYPEOF(csa)
    ) AND (csa.name = 'uncut volume')) AND (SIZEOF(QUERY (sar <*
    csa.component_relationships| (
    'INTEGRATED_CNC_SCHEMA.FEATURE_COMPONENT_RELATIONSHIP' IN
    TYPEOF(sar)) AND (SIZEOF([ 'INTEGRATED_CNC_SCHEMA.BOSS',
    'INTEGRATED_CNC_SCHEMA.PROTRUSION' ] * TYPEOF(sar.
    related_shape_aspect)) = 1))) = 1))) <= 1))) = 1);

WR17: NOT (SELF\characterized_object.description IN [
  'closed rectangular', 'open rectangular' ]) OR (SIZEOF(QUERY
  (pds <* QUERY (pd <* USEDIN(SELF,
    'INTEGRATED_CNC_SCHEMA.PROPERTY_DEFINITION.DEFINITION')| (
    'INTEGRATED_CNC_SCHEMA.PRODUCT_DEFINITION_SHAPE' IN TYPEOF(pd
  )))| NOT (SIZEOF(QUERY (sa_occ <* USEDIN(pds,
    'INTEGRATED_CNC_SCHEMA.SHAPE_ASPECT.OF_SHAPE')| (sa_occ.
    description = 'change in boundary occurrence') AND (SIZEOF(
    QUERY (fcr <* QUERY (sar <* USEDIN(sa_occ,
    'INTEGRATED_CNC_SCHEMA.SHAPE_ASPECT_RELATIONSHIP.' +
    'RELATING_SHAPE_ASPECT')| (sar.description = 'taper usage')
    AND ('INTEGRATED_CNC_SCHEMA.FEATURE_COMPONENT_RELATIONSHIP'
    IN TYPEOF(sar)))| (('INTEGRATED_CNC_SCHEMA.TAPER' IN TYPEOF(
    fcr.relying_shape_aspect)) AND (
    'INTEGRATED_CNC_SCHEMA.POCKET' IN TYPEOF(fcr.
    related_shape_aspect.of_shape.definition))) AND (fcr.
    related_shape_aspect.description IN [ 'angle taper',
    'directed taper' ]))) >= 1))) <= 1))) = 0);

```

```
END_ENTITY; -- 10303-522: aic_machining_feature
```

```
ENTITY pocket_bottom
```

```
  SUBTYPE OF (shape_aspect);
```

```
  WHERE
```

```
    WR1: 'INTEGRATED_CNC_SCHEMA.FEATURE_COMPONENT_DEFINITION' IN TYPEOF(
      SELF.of_shape.definition);
    WR2: SELF.description IN [ 'planar', 'complex', 'through' ];
    WR3: NOT (SELF.description = 'planar') OR (SIZEOF(QUERY (pd <* USEDIN(
      SELF, 'INTEGRATED_CNC_SCHEMA.PROPERTY_DEFINITION.DEFINITION')
      | NOT (SIZEOF(QUERY (pdr <* USEDIN(pd,
      'INTEGRATED_CNC_SCHEMA.' +
      'PROPERTY_DEFINITION_REPRESENTATION.DEFINITION') | (
      'INTEGRATED_CNC_SCHEMA.DIRECTION_SHAPE_REPRESENTATION' IN
      TYPEOF(pdr.used_representation)) AND (pdr.used_representation
      .name = 'floor normal')))) = 1))) = 0);
    WR4: NOT (SELF.description = 'planar') OR (SIZEOF(QUERY (pd <* USEDIN(
      SELF, 'INTEGRATED_CNC_SCHEMA.PROPERTY_DEFINITION.DEFINITION')
      | NOT (SIZEOF(QUERY (pdr <* USEDIN(pd,
      'INTEGRATED_CNC_SCHEMA.' +
      'PROPERTY_DEFINITION_REPRESENTATION.DEFINITION') | (
      'INTEGRATED_CNC_SCHEMA.LOCATION_SHAPE_REPRESENTATION' IN
      TYPEOF(pdr.used_representation)) AND (pdr.used_representation
      .name = 'floor location')))) = 1))) = 0);
    WR5: NOT (SELF.description = 'complex') OR (SIZEOF(QUERY (pd <* USEDIN(
      SELF, 'INTEGRATED_CNC_SCHEMA.PROPERTY_DEFINITION.DEFINITION')
      | NOT (SIZEOF(QUERY (pdr <* USEDIN(pd,
      'INTEGRATED_CNC_SCHEMA.' +
      'PROPERTY_DEFINITION_REPRESENTATION.DEFINITION') | (
      'INTEGRATED_CNC_SCHEMA.FACE_SHAPE_REPRESENTATION' IN TYPEOF(
      pdr.used_representation)) AND (pdr.used_representation.name =
      'floor face')))) = 1))) = 0);
    WR6: NOT (SELF.description IN [ 'planar', 'complex' ]) OR (SIZEOF(QUERY
      (pd <* USEDIN(SELF,
      'INTEGRATED_CNC_SCHEMA.PROPERTY_DEFINITION.DEFINITION') | NOT
      (SIZEOF(QUERY (pdr <* USEDIN(pd, 'INTEGRATED_CNC_SCHEMA.' +
      'PROPERTY_DEFINITION_REPRESENTATION.DEFINITION') | (
      'INTEGRATED_CNC_SCHEMA.' +
      'SHAPE_REPRESENTATION_WITH_PARAMETERS' IN TYPEOF(pdr.
      used_representation)))) = 1))) = 0);
    WR7: NOT (SELF.description IN [ 'planar', 'complex' ]) OR (SIZEOF(QUERY
      (pd <* USEDIN(SELF,
      'INTEGRATED_CNC_SCHEMA.PROPERTY_DEFINITION.DEFINITION') | NOT
      (SIZEOF(QUERY (impl_rep <* QUERY (pdr <* USEDIN(pd,
      'INTEGRATED_CNC_SCHEMA.' +
      'PROPERTY_DEFINITION_REPRESENTATION.DEFINITION') | (
      'INTEGRATED_CNC_SCHEMA.' +
      'SHAPE_REPRESENTATION_WITH_PARAMETERS' IN TYPEOF(pdr.
      used_representation))) | NOT (SIZEOF(impl_rep.
      used_representation.items) <= 1))) = 0))) = 0);
    WR8: NOT (SELF.description = 'through') OR (SIZEOF(QUERY (pd <* USEDIN(
      SELF, 'INTEGRATED_CNC_SCHEMA.PROPERTY_DEFINITION.DEFINITION')
      | NOT (SIZEOF(QUERY (pdr <* USEDIN(pd,
      'INTEGRATED_CNC_SCHEMA.' +
```



```

        'PROPERTY_DEFINITION_REPRESENTATION.DEFINITION')| (
        'INTEGRATED_CNC_SCHEMA.' +
        'SHAPE_REPRESENTATION_WITH_PARAMETERS' IN TYPEOF(pdr.
used_representation)))) = 0))) = 0);
WR9: NOT (SELF.description IN [ 'planar', 'complex' ]) OR (SIZEOF(QUERY
    (pd <* USEDIN(SELF,
        'INTEGRATED_CNC_SCHEMA.PROPERTY_DEFINITION.DEFINITION')| NOT
        (SIZEOF(QUERY (impl_rep <* QUERY (pdr <* USEDIN(pd,
            'INTEGRATED_CNC_SCHEMA.' +
            'PROPERTY_DEFINITION_REPRESENTATION.DEFINITION')| (
            'INTEGRATED_CNC_SCHEMA.' +
            'SHAPE_REPRESENTATION_WITH_PARAMETERS' IN TYPEOF(pdr.
            used_representation)))| NOT (SIZEOF(QUERY (it <* impl_rep.
            used_representation.items| (SIZEOF([
                'INTEGRATED_CNC_SCHEMA.MEASURE_REPRESENTATION_ITEM',
                'INTEGRATED_CNC_SCHEMA.LENGTH_MEASURE_WITH_UNIT' ] * TYPEOF(
                it)) = 2) AND (it.name = 'radius')) <= 1))) = 0))) = 0);
WR10: SIZEOF(QUERY (fcr <* QUERY (sar <* USEDIN(SELF,
        'INTEGRATED_CNC_SCHEMA.SHAPE_ASPECT_RELATIONSHIP.' +
        'RELATING_SHAPE_ASPECT')| (sar.description =
        'pocket bottom usage') AND (
        'INTEGRATED_CNC_SCHEMA.FEATURE_COMPONENT_RELATIONSHIP' IN
        TYPEOF(sar)))| ((fcr.related_shape_aspect.description =
        'bottom condition occurrence') AND (
        'INTEGRATED_CNC_SCHEMA.POCKET' IN TYPEOF(fcr.
        related_shape_aspect.of_shape.definition))) AND (
        'INTEGRATED_CNC_SCHEMA.POCKET_BOTTOM' IN TYPEOF(fcr.
        relating_shape_aspect)))) >= 1;
WR11: NOT (SELF.description IN [ 'planar', 'complex' ]) OR (SIZEOF(
        QUERY (fcr <* QUERY (sar <* USEDIN(SELF,
            'INTEGRATED_CNC_SCHEMA.SHAPE_ASPECT_RELATIONSHIP.' +
            'RELATING_SHAPE_ASPECT')| (sar.description =
            'pocket bottom usage') AND (
            'INTEGRATED_CNC_SCHEMA.FEATURE_COMPONENT_RELATIONSHIP' IN
            TYPEOF(sar)))| (fcr.related_shape_aspect.description =
            'bottom condition occurrence') AND (fcr.related_shape_aspect.
            name IN [ 'pocket depth start', 'pocket depth end' ]))) = 0);
END_ENTITY; -- 10303-522: aic_machining_feature

```

ENTITY point

```

    SUPERTYPE OF (ONEOF(cartesian_point, point_on_curve, point_on_surface,
        point_replica, degenerate_pcurve))
    SUBTYPE OF (geometric_representation_item);
END_ENTITY; -- 10303-42: geometry_schema

```

ENTITY point\_on\_curve

```

    SUBTYPE OF (point);
    basis_curve      : curve;
    point_parameter  : parameter_value;
END_ENTITY; -- 10303-42: geometry_schema

```

ENTITY point\_on\_surface

```

    SUBTYPE OF (point);
    basis_surface    : surface;

```

## ISO 10303-238:2007(E)

```
    point_parameter_u : parameter_value;
    point_parameter_v : parameter_value;
END_ENTITY; -- 10303-42: geometry_schema

ENTITY point_replica
  SUBTYPE OF (point);
  parent_pt      : point;
  transformation : cartesian_transformation_operator;
  WHERE
    WR1: transformation.dim = parent_pt.dim;
    WR2: acyclic_point_replica(SELF, parent_pt);
END_ENTITY; -- 10303-42: geometry_schema

ENTITY poly_loop
  SUBTYPE OF (loop, geometric_representation_item);
  polygon : LIST [3:?] OF UNIQUE cartesian_point;
END_ENTITY; -- 10303-42: topology_schema

ENTITY polyline
  SUBTYPE OF (bounded_curve);
  points : LIST [2:?] OF cartesian_point;
END_ENTITY; -- 10303-42: geometry_schema

ENTITY position_tolerance
  SUBTYPE OF (geometric_tolerance);
  WHERE
    WR1: NOT ('INTEGRATED_CNC_SCHEMA.' +
              'GEOMETRIC_TOLERANCE_WITH_DATUM_REFERENCE' IN TYPEOF(SELF))
          OR (SIZEOF(SELF\geometric_tolerance_with_datum_reference.
                    datum_system) <= 3);
END_ENTITY; -- 10303-519: aic_geometric_tolerances

ENTITY pre_defined_item;
  name : label;
END_ENTITY; -- 10303-41: external_reference_schema

ENTITY precision_qualifier;
  precision_value : INTEGER;
END_ENTITY; -- 10303-45: qualified_measure_schema

ENTITY process_product_association;
  name          : label;
  description   : text;
  defined_product : characterized_product_definition;
  process       : product_definition_process;
END_ENTITY; -- 10303-49: process_property_schema

ENTITY process_property_association;
  name          : label;
  description   : text;
  process       : property_process;
  property_or_shape : property_or_shape_select;
END_ENTITY; -- 10303-49: process_property_schema
```

```

ENTITY product;
  id          : identifier;
  name       : label;
  description : OPTIONAL text;
  frame_of_reference : SET [1:?] OF product_context;
END_ENTITY; -- 10303-41: product_definition_schema

ENTITY product_category;
  name       : label;
  description : OPTIONAL text;
  DERIVE
  id : identifier := get_id_value(SELF);
  WHERE
  WR1: SIZEOF(USEDIN(SELF, 'INTEGRATED_CNC_SCHEMA.' +
                    'ID_ATTRIBUTE.IDENTIFIED_ITEM')) <= 1;
END_ENTITY; -- 10303-41: product_definition_schema

ENTITY product_category_relationship;
  name       : label;
  description : OPTIONAL text;
  category   : product_category;
  sub_category : product_category;
  WHERE
  WR1: acyclic_product_category_relationship(SELF, [ SELF.sub_category ])
      ;
END_ENTITY; -- 10303-41: product_definition_schema

ENTITY product_context
  SUBTYPE OF (application_context_element);
  discipline_type : label;
END_ENTITY; -- 10303-41: application_context_schema

ENTITY product_definition;
  id          : identifier;
  description : OPTIONAL text;
  formation   : product_definition_formation;
  frame_of_reference : product_definition_context;
  DERIVE
  name : label := get_name_value(SELF);
  WHERE
  WR1: SIZEOF(USEDIN(SELF, 'INTEGRATED_CNC_SCHEMA.' +
                    'NAME_ATTRIBUTE.NAMED_ITEM')) <= 1;
END_ENTITY; -- 10303-41: product_definition_schema

ENTITY product_definition_context
  SUBTYPE OF (application_context_element);
  life_cycle_stage : label;
END_ENTITY; -- 10303-41: application_context_schema

ENTITY product_definition_formation;
  id          : identifier;
  description : OPTIONAL text;
  of_product  : product;
  UNIQUE

```

## ISO 10303-238:2007(E)

```
    UR1: id, of_product;
END_ENTITY; -- 10303-41: product_definition_schema

ENTITY product_definition_formation_with_specified_source
  SUBTYPE OF (product_definition_formation);
  make_or_buy : source;
END_ENTITY; -- 10303-41: product_definition_schema

ENTITY product_definition_process
  SUBTYPE OF (action);
  identification : identifier;
  INVERSE
    product_definitions : SET [1:?] OF process_product_association FOR
      process;
END_ENTITY; -- 10303-49: process_property_schema

ENTITY product_definition_relationship;
  id : identifier;
  name : label;
  description : OPTIONAL text;
  relating_product_definition : product_definition;
  related_product_definition : product_definition;
END_ENTITY; -- 10303-41: product_definition_schema

ENTITY product_definition_shape
  SUBTYPE OF (property_definition);
  UNIQUE
    UR1: SELF\property_definition.definition;
  WHERE
    WR1: SIZEOF([ 'INTEGRATED_CNC_SCHEMA.CHARACTERIZED_PRODUCT_DEFINITION',
      'INTEGRATED_CNC_SCHEMA.CHARACTERIZED_OBJECT' ] * TYPEOF(SELF
        \property_definition.definition)) > 0;
END_ENTITY; -- 10303-41: product_property_definition_schema

ENTITY product_definition_usage
  SUPERTYPE OF (ONEOF(make_from_usage_option, assembly_component_usage))
  SUBTYPE OF (product_definition_relationship);
  UNIQUE
    UR1: SELF\product_definition_relationship.id,
      SELF\product_definition_relationship.relatng_product_definition,
      SELF\product_definition_relationship.related_product_definition;
  WHERE
    WR1: acyclic_product_definition_relationship(SELF, [ SELF\
      product_definition_relationship.related_product_definition ],
      'INTEGRATED_CNC_SCHEMA.PRODUCT_DEFINITION_USAGE');
END_ENTITY; -- 10303-44: product_structure_schema

ENTITY product_definition_with_associated_documents
  SUBTYPE OF (product_definition);
  documentation_ids : SET [1:?] OF document;
END_ENTITY; -- 10303-41: product_definition_schema

ENTITY product_related_product_category
  SUBTYPE OF (product_category);
```

```

    products : SET [1:?] OF product;
END_ENTITY; -- 10303-41: product_definition_schema

ENTITY profile_floor
  SUBTYPE OF (shape_aspect);
  WHERE
    WR1: 'INTEGRATED_CNC_SCHEMA.FEATURE_COMPONENT_DEFINITION' IN TYPEOF(
      SELF.of_shape.definition);
    WR2: SELF.description IN [ 'planar', 'complex', 'through' ];
    WR3: NOT (SELF.description IN [ 'planar', 'complex' ]) OR (SIZEOF(QUERY
      (pd <* USEDIN(SELF,
        'INTEGRATED_CNC_SCHEMA.PROPERTY_DEFINITION.DEFINITION')| NOT
        (SIZEOF(QUERY (pdr <* USEDIN(pd, 'INTEGRATED_CNC_SCHEMA.' +
          'PROPERTY_DEFINITION_REPRESENTATION.DEFINITION')| (
            'INTEGRATED_CNC_SCHEMA.' +
            'SHAPE_REPRESENTATION_WITH_PARAMETERS' IN TYPEOF(pdr.
            used_representation)))) = 1))) = 0);
    WR4: NOT (SELF.description IN [ 'planar', 'complex' ]) OR (SIZEOF(QUERY
      (pd <* USEDIN(SELF,
        'INTEGRATED_CNC_SCHEMA.PROPERTY_DEFINITION.DEFINITION')| NOT
        (SIZEOF(QUERY (impl_rep <* QUERY (pdr <* USEDIN(pd,
          'INTEGRATED_CNC_SCHEMA.' +
          'PROPERTY_DEFINITION_REPRESENTATION.DEFINITION')| (
            'INTEGRATED_CNC_SCHEMA.' +
            'SHAPE_REPRESENTATION_WITH_PARAMETERS' IN TYPEOF(pdr.
            used_representation))))| NOT (SIZEOF(impl_rep.
            used_representation.items) >= 1) AND (SIZEOF(impl_rep.
            used_representation.items) <= 2))) = 0))) = 0);
    WR5: NOT (SELF.description = 'through') OR (SIZEOF(QUERY (pd <* USEDIN(
      SELF, 'INTEGRATED_CNC_SCHEMA.PROPERTY_DEFINITION.DEFINITION')
      | NOT (SIZEOF(QUERY (pdr <* USEDIN(pd,
        'INTEGRATED_CNC_SCHEMA.' +
        'PROPERTY_DEFINITION_REPRESENTATION.DEFINITION')| (
          'INTEGRATED_CNC_SCHEMA.' +
          'SHAPE_REPRESENTATION_WITH_PARAMETERS' IN TYPEOF(pdr.
          used_representation)))) = 0))) = 0);
    WR6: NOT (SELF.description IN [ 'planar', 'complex' ]) OR (SIZEOF(QUERY
      (pd <* USEDIN(SELF,
        'INTEGRATED_CNC_SCHEMA.PROPERTY_DEFINITION.DEFINITION')| NOT
        (SIZEOF(QUERY (impl_rep <* QUERY (pdr <* USEDIN(pd,
          'INTEGRATED_CNC_SCHEMA.' +
          'PROPERTY_DEFINITION_REPRESENTATION.DEFINITION')| (
            'INTEGRATED_CNC_SCHEMA.' +
            'SHAPE_REPRESENTATION_WITH_PARAMETERS' IN TYPEOF(pdr.
            used_representation))))| NOT (SIZEOF(QUERY (it <* impl_rep.
            used_representation.items| (SIZEOF([
              'INTEGRATED_CNC_SCHEMA.MEASURE_REPRESENTATION_ITEM',
              'INTEGRATED_CNC_SCHEMA.LENGTH_MEASURE_WITH_UNIT' ] * TYPEOF(
              it)) = 2) AND (it.name = 'radius')) = 1))) = 0))) = 0);
    WR7: SIZEOF(QUERY (fcr <* QUERY (sar <* USEDIN(SELF,
      'INTEGRATED_CNC_SCHEMA.SHAPE_ASPECT_RELATIONSHIP.' +
      'RELATING_SHAPE_ASPECT')| (sar.description =
      'profile floor usage') AND (
      'INTEGRATED_CNC_SCHEMA.FEATURE_COMPONENT_RELATIONSHIP' IN

```

```

        TYPEOF(sar))) | ('INTEGRATED_CNC_SCHEMA.OUTSIDE_PROFILE' IN
        TYPEOF(fcr.related_shape_aspect.of_shape.definition)) AND (
        'INTEGRATED_CNC_SCHEMA.PROFILE_FLOOR' IN TYPEOF(fcr.
        relating_shape_aspect)))) >= 1;
WR8: NOT (SELF.description IN [ 'planar', 'complex' ]) OR (SIZEOF(QUERY
        (pd <* USEDIN(SELF,
        'INTEGRATED_CNC_SCHEMA.PROPERTY_DEFINITION.DEFINITION') | NOT
        (SIZEOF(QUERY (impl_rep <* QUERY (pdr <* USEDIN(pd,
        'INTEGRATED_CNC_SCHEMA.' +
        'PROPERTY_DEFINITION_REPRESENTATION.DEFINITION') | (
        'INTEGRATED_CNC_SCHEMA.' +
        'SHAPE_REPRESENTATION_WITH_PARAMETERS' IN TYPEOF(pdr.
        used_representation))) | NOT (SIZEOF(QUERY (it <* impl_rep.
        used_representation.items | ((
        'INTEGRATED_CNC_SCHEMA.DESRIPTIVE_REPRESENTATION_ITEM' IN
        TYPEOF(it)) AND (it.name = 'shape profile floor orientation')
        ) AND (it.description IN [ 'shape profile start',
        'shape profile end' ]))) = 1))) = 0))) = 0);
WR9: NOT (SELF.description = 'complex') OR (SIZEOF(QUERY (pd <* USEDIN(
        SELF, 'INTEGRATED_CNC_SCHEMA.PROPERTY_DEFINITION.DEFINITION')
        | NOT (SIZEOF(QUERY (pdr <* USEDIN(pd,
        'INTEGRATED_CNC_SCHEMA.' +
        'PROPERTY_DEFINITION_REPRESENTATION.DEFINITION') | (
        'INTEGRATED_CNC_SCHEMA.FACE_SHAPE_REPRESENTATION' IN TYPEOF(
        pdr.used_representation)) AND (pdr.used_representation.name =
        'floor'))) = 1))) = 1);
WR10: NOT (SELF.description = 'planar') OR (SIZEOF(QUERY (pd <* USEDIN(
        SELF, 'INTEGRATED_CNC_SCHEMA.PROPERTY_DEFINITION.DEFINITION')
        | NOT (SIZEOF(QUERY (pdr <* USEDIN(pd,
        'INTEGRATED_CNC_SCHEMA.' +
        'PROPERTY_DEFINITION_REPRESENTATION.DEFINITION') | (
        'INTEGRATED_CNC_SCHEMA.PLANAR_SHAPE_REPRESENTATION' IN TYPEOF
        (pdr.used_representation)) AND (pdr.used_representation.name
        = 'floor'))) = 1))) = 1);
END_ENTITY; -- 10303-522: aic_machining_feature

ENTITY projected_zone_definition
  SUBTYPE OF (tolerance_zone_definition);
  projection_end      : shape_aspect;
  projected_length    : measure_with_unit;
  WHERE
    WR1: ('NUMBER' IN TYPEOF(projected_length\measure_with_unit.
        value_component)) AND (projected_length\measure_with_unit.
        value_component > 0.0);
    WR2: derive_dimensional_exponents(projected_length\measure_with_unit.
        unit_component) = dimensional_exponents(1, 0, 0, 0, 0, 0, 0);
END_ENTITY; -- 10303-47: shape_tolerance_schema

ENTITY property_definition;
  name      : label;
  description : OPTIONAL text;
  definition : characterized_definition;
  DERIVE
    id : identifier := get_id_value(SELF);

```

```

WHERE
  WR1: SIZEOF(USEDIN(SELF, 'INTEGRATED_CNC_SCHEMA.' +
    'ID_ATTRIBUTE.IDENTIFIED_ITEM')) <= 1;
END_ENTITY; -- 10303-41: product_property_definition_schema

ENTITY property_definition_representation;
  definition      : represented_definition;
  used_representation : representation;
DERIVE
  description : text := get_description_value(SELF);
  name       : label := get_name_value(SELF);
WHERE
  WR1: SIZEOF(USEDIN(SELF, 'INTEGRATED_CNC_SCHEMA.' +
    'DESCRIPTION_ATTRIBUTE.DESCRIBED_ITEM')) <= 1;
  WR2: SIZEOF(USEDIN(SELF, 'INTEGRATED_CNC_SCHEMA.' +
    'NAME_ATTRIBUTE.NAMED_ITEM')) <= 1;
END_ENTITY; -- 10303-41: product_property_representation_schema

ENTITY property_process
  SUBTYPE OF (action);
  identification : identifier;
  INVERSE
    properties : SET [1:?] OF process_property_association FOR process;
END_ENTITY; -- 10303-49: process_property_schema

ENTITY protrusion
  SUBTYPE OF (feature_definition);
  WHERE
    WR1: SIZEOF(QUERY (pd <* USEDIN(SELF,
      'INTEGRATED_CNC_SCHEMA.PROPERTY_DEFINITION.DEFINITION') | NOT
      (SIZEOF(QUERY (impl_rep <* QUERY (pdr <* USEDIN(pd,
        'INTEGRATED_CNC_SCHEMA.' +
        'PROPERTY_DEFINITION_REPRESENTATION.DEFINITION') | (
        'INTEGRATED_CNC_SCHEMA.' +
        'SHAPE_REPRESENTATION_WITH_PARAMETERS' IN TYPEOF(pdr.
        used_representation)))) | NOT (SIZEOF(impl_rep.
        used_representation.items) = 1))) = 0))) = 0;
    WR2: SIZEOF(QUERY (pds <* QUERY (pd <* USEDIN(SELF,
      'INTEGRATED_CNC_SCHEMA.PROPERTY_DEFINITION.DEFINITION') | (
      'INTEGRATED_CNC_SCHEMA.PRODUCT_DEFINITION_SHAPE' IN TYPEOF(pd
      ))) | NOT (SIZEOF(QUERY (sa_occ <* USEDIN(pds,
        'INTEGRATED_CNC_SCHEMA.SHAPE_ASPECT.OF_SHAPE') | (sa_occ.
        description = 'shape volume occurrence') AND (SIZEOF(QUERY (
        sdr <* QUERY (sar <* USEDIN(sa_occ,
        'INTEGRATED_CNC_SCHEMA.SHAPE_ASPECT_RELATIONSHIP.' +
        'RELATED_SHAPE_ASPECT') | (sar.description =
        'volume shape usage') AND (
        'INTEGRATED_CNC_SCHEMA.SHAPE_DEFINING_RELATIONSHIP' IN TYPEOF
        (sar)))) | (sdr.relating_shape_aspect.description =
        'volume shape')))) = 1))) = 1))) = 0;
    WR3: SIZEOF(QUERY (pdr <* get_property_definition_representations(SELF)
      | ('INTEGRATED_CNC_SCHEMA.PLANAR_SHAPE_REPRESENTATION' IN
      TYPEOF(pdr.used_representation)) AND (pdr.used_representation
      .name = 'maximum feature limit')) >= 0;

```

ISO 10303-238:2007(E)

```

END_ENTITY; -- 10303-522: aic_machining_feature

ENTITY qualified_representation_item
  SUBTYPE OF (representation_item);
  qualifiers : SET [1:?] OF value_qualifier;
  WHERE
    WR1: SIZEOF(QUERY (temp <* qualifiers| (
      'INTEGRATED_CNC_SCHEMA.PRECISION_QUALIFIER' IN TYPEOF(temp)))
      ) < 2;
END_ENTITY; -- 10303-45: qualified_measure_schema

ENTITY qualitative_uncertainty
  SUBTYPE OF (uncertainty_qualifier);
  uncertainty_value : text;
END_ENTITY; -- 10303-45: qualified_measure_schema

ENTITY quasi_uniform_curve
  SUBTYPE OF (b_spline_curve);
END_ENTITY; -- 10303-42: geometry_schema

ENTITY quasi_uniform_surface
  SUBTYPE OF (b_spline_surface);
END_ENTITY; -- 10303-42: geometry_schema

ENTITY ratio_measure_with_unit
  SUBTYPE OF (measure_with_unit);
  WHERE
    WR1: 'INTEGRATED_CNC_SCHEMA.RATIO_UNIT' IN TYPEOF(SELF\
      measure_with_unit.unit_component);
END_ENTITY; -- 10303-41: measure_schema

ENTITY ratio_unit
  SUBTYPE OF (named_unit);
  WHERE
    WR1: ((((((SELF\named_unit.dimensions.length_exponent = 0.0) AND (SELF\
      named_unit.dimensions.mass_exponent = 0.0)) AND (SELF\
      named_unit.dimensions.time_exponent = 0.0)) AND (SELF\
      named_unit.dimensions.electric_current_exponent = 0.0)) AND (
      SELF\named_unit.dimensions.thermodynamic_temperature_exponent
      = 0.0)) AND (SELF\named_unit.dimensions.
      amount_of_substance_exponent = 0.0)) AND (SELF\named_unit.
      dimensions.luminous_intensity_exponent = 0.0);
END_ENTITY; -- 10303-41: measure_schema

ENTITY rational_b_spline_curve
  SUBTYPE OF (b_spline_curve);
  weights_data : LIST [2:?] OF REAL;
  DERIVE
    weights : ARRAY [0:upper_index_on_control_points] OF REAL :=
      list_to_array(weights_data, 0,
        upper_index_on_control_points);
  WHERE
    WR1: SIZEOF(weights_data) = SIZEOF(SELF\b_spline_curve.
      control_points_list);

```



```

    WR2: curve_weights_positive(SELF);
END_ENTITY; -- 10303-42: geometry_schema

ENTITY rational_b_spline_surface
  SUBTYPE OF (b_spline_surface);
  weights_data : LIST [2:?] OF LIST [2:?] OF REAL;
  DERIVE
    weights : ARRAY [0:u_upper] OF ARRAY [0:v_upper] OF REAL :=
      make_array_of_array(weights_data, 0, u_upper, 0, v_upper);
  WHERE
    WR1: (SIZEOF(weights_data) = SIZEOF(SELF\b_spline_surface.
      control_points_list)) AND (SIZEOF(weights_data[1]) = SIZEOF(
      SELF\b_spline_surface.control_points_list[1]));
    WR2: surface_weights_positive(SELF);
END_ENTITY; -- 10303-42: geometry_schema

ENTITY real_literal
  SUBTYPE OF (literal_number);
  SELF\literal_number.the_value : REAL;
END_ENTITY; -- 13584-20: iso13584_expressions_schema

ENTITY real_numeric_variable
  SUBTYPE OF (numeric_variable);
END_ENTITY; -- 13584-20: iso13584_expressions_schema

ENTITY rectangular_closed_profile
  SUBTYPE OF (shape_aspect);
  WHERE
    WR1: 'INTEGRATED_CNC_SCHEMA.FEATURE_COMPONENT_DEFINITION' IN TYPEOF(
      SELF.of_shape.definition);
    WR2: SIZEOF(QUERY (pd <* USEDIN(SELF,
      'INTEGRATED_CNC_SCHEMA.PROPERTY_DEFINITION.DEFINITION') | NOT
      (SIZEOF(QUERY (pdr <* USEDIN(pd, 'INTEGRATED_CNC_SCHEMA.' +
      'PROPERTY_DEFINITION_REPRESENTATION.DEFINITION') | (
      'INTEGRATED_CNC_SCHEMA.' +
      'SHAPE_REPRESENTATION_WITH_PARAMETERS' IN TYPEOF(pdr.
      used_representation)))) = 1))) = 0;
    WR3: SIZEOF(QUERY (pd <* USEDIN(SELF,
      'INTEGRATED_CNC_SCHEMA.PROPERTY_DEFINITION.DEFINITION') | NOT
      (SIZEOF(QUERY (impl_rep <* QUERY (pdr <* USEDIN(pd,
      'INTEGRATED_CNC_SCHEMA.' +
      'PROPERTY_DEFINITION_REPRESENTATION.DEFINITION') | (
      'INTEGRATED_CNC_SCHEMA.' +
      'SHAPE_REPRESENTATION_WITH_PARAMETERS' IN TYPEOF(pdr.
      used_representation))) | NOT ((SIZEOF(impl_rep.
      used_representation.items) >= 3) AND (SIZEOF(impl_rep.
      used_representation.items) <= 4)))) = 0))) = 0;
    WR4: SIZEOF(QUERY (pd <* USEDIN(SELF, 'INTEGRATED_CNC_SCHEMA.' +
      'PROPERTY_DEFINITION.DEFINITION') | (SIZEOF(QUERY (pdr <*
      USEDIN(pd, 'INTEGRATED_CNC_SCHEMA.' +
      'PROPERTY_DEFINITION_REPRESENTATION.DEFINITION') | (
      'INTEGRATED_CNC_SCHEMA.SHAPE_REPRESENTATION_WITH_PARAMETERS'
      IN TYPEOF(pdr.used_representation)) AND (SIZEOF(QUERY (srwp_i
      <* pdr.used_representation.items | ((srwp_i.name =

```

```

        'orientation') OR (srwp_i.name = 'length')) OR (srwp_i.name =
        'width')) OR (srwp_i.name = 'corner radius')) = SIZEOF(pdr.
        used_representation.items))) = 1))) = 1;
WR5: SIZEOF(QUERY (pd <* USEDIN(SELF,
        'INTEGRATED_CNC_SCHEMA.PROPERTY_DEFINITION.DEFINITION')| NOT
        (SIZEOF(QUERY (impl_rep <* QUERY (pdr <* USEDIN(pd,
        'INTEGRATED_CNC_SCHEMA.' +
        'PROPERTY_DEFINITION_REPRESENTATION.DEFINITION')| (
        'INTEGRATED_CNC_SCHEMA.' +
        'SHAPE_REPRESENTATION_WITH_PARAMETERS' IN TYPEOF(pdr.
        used_representation)))| NOT (SIZEOF(QUERY (it <* impl_rep.
        used_representation.items| ('INTEGRATED_CNC_SCHEMA.PLACEMENT'
        IN TYPEOF(it)) AND (it.name = 'orientation')) = 1))) = 0)))
        = 0;
WR6: SIZEOF(QUERY (pd <* USEDIN(SELF,
        'INTEGRATED_CNC_SCHEMA.PROPERTY_DEFINITION.DEFINITION')| NOT
        (SIZEOF(QUERY (impl_rep <* QUERY (pdr <* USEDIN(pd,
        'INTEGRATED_CNC_SCHEMA.' +
        'PROPERTY_DEFINITION_REPRESENTATION.DEFINITION')| (
        'INTEGRATED_CNC_SCHEMA.' +
        'SHAPE_REPRESENTATION_WITH_PARAMETERS' IN TYPEOF(pdr.
        used_representation)))| NOT (SIZEOF(QUERY (it <* impl_rep.
        used_representation.items| (SIZEOF([
        'INTEGRATED_CNC_SCHEMA.MEASURE_REPRESENTATION_ITEM',
        'INTEGRATED_CNC_SCHEMA.LENGTH_MEASURE_WITH_UNIT' ] * TYPEOF(
        it)) = 2) AND (it.name = 'width')) = 1))) = 0))) = 0;
WR7: SIZEOF(QUERY (pd <* USEDIN(SELF,
        'INTEGRATED_CNC_SCHEMA.PROPERTY_DEFINITION.DEFINITION')| NOT
        (SIZEOF(QUERY (impl_rep <* QUERY (pdr <* USEDIN(pd,
        'INTEGRATED_CNC_SCHEMA.' +
        'PROPERTY_DEFINITION_REPRESENTATION.DEFINITION')| (
        'INTEGRATED_CNC_SCHEMA.' +
        'SHAPE_REPRESENTATION_WITH_PARAMETERS' IN TYPEOF(pdr.
        used_representation)))| NOT (SIZEOF(QUERY (it <* impl_rep.
        used_representation.items| (SIZEOF([
        'INTEGRATED_CNC_SCHEMA.MEASURE_REPRESENTATION_ITEM',
        'INTEGRATED_CNC_SCHEMA.LENGTH_MEASURE_WITH_UNIT' ] * TYPEOF(
        it)) = 2) AND (it.name = 'length')) = 1))) = 0))) = 0;
WR8: SIZEOF(QUERY (pd <* USEDIN(SELF,
        'INTEGRATED_CNC_SCHEMA.PROPERTY_DEFINITION.DEFINITION')| NOT
        (SIZEOF(QUERY (impl_rep <* QUERY (pdr <* USEDIN(pd,
        'INTEGRATED_CNC_SCHEMA.' +
        'PROPERTY_DEFINITION_REPRESENTATION.DEFINITION')| (
        'INTEGRATED_CNC_SCHEMA.' +
        'SHAPE_REPRESENTATION_WITH_PARAMETERS' IN TYPEOF(pdr.
        used_representation)))| NOT (SIZEOF(QUERY (it <* impl_rep.
        used_representation.items| (SIZEOF([
        'INTEGRATED_CNC_SCHEMA.MEASURE_REPRESENTATION_ITEM',
        'INTEGRATED_CNC_SCHEMA.LENGTH_MEASURE_WITH_UNIT' ] * TYPEOF(
        it)) = 2) AND (it.name = 'corner radius')) <= 1))) = 0))) =
        0;
END_ENTITY; -- 10303-522: aic_machining_feature

ENTITY rectangular_composite_surface

```

```

SUBTYPE OF (bounded_surface);
  segments : LIST [1:?] OF LIST [1:?] OF surface_patch;
DERIVE
  n_u : INTEGER := SIZEOF(segments);
  n_v : INTEGER := SIZEOF(segments[1]);
WHERE
  WR1: SIZEOF(QUERY (s <* segments| (n_v <> SIZEOF(s)))) = 0;
  WR2: constraints_rectangular_composite_surface(SELf);
END_ENTITY; -- 10303-42: geometry_schema

ENTITY rectangular_pattern
SUBTYPE OF (replicate_feature);
WHERE
  WR1: SIZEOF(QUERY (pds <* QUERY (pd <* USEDIN(SELf,
    'INTEGRATED_CNC_SCHEMA.PROPERTY_DEFINITION.DEFINITION')| (
    'INTEGRATED_CNC_SCHEMA.PRODUCT_DEFINITION_SHAPE' IN TYPEOF(pd
    )))| NOT (SIZEOF(QUERY (sa_occ <* USEDIN(pds,
    'INTEGRATED_CNC_SCHEMA.SHAPE_ASPECT.OF_SHAPE')| (SIZEOF(QUERY
    (sdr <* QUERY (sar <* USEDIN(sa_occ,
    'INTEGRATED_CNC_SCHEMA.SHAPE_ASPECT_RELATIONSHIP.' +
    'RELATING_SHAPE_ASPECT')| (
    'INTEGRATED_CNC_SCHEMA.FEATURE_COMPONENT_RELATIONSHIP' IN
    TYPEOF(sar))))| ('INTEGRATED_CNC_SCHEMA.SHAPE_ASPECT' IN
    TYPEOF(sdr.related_shape_aspect)))) = 1))) <= 5))) = 0;
  WR2: SIZEOF(QUERY (pd <* USEDIN(SELf,
    'INTEGRATED_CNC_SCHEMA.PROPERTY_DEFINITION.DEFINITION')| NOT
    (SIZEOF(QUERY (pdr <* USEDIN(pd, 'INTEGRATED_CNC_SCHEMA.' +
    'PROPERTY_DEFINITION_REPRESENTATION.DEFINITION')| (
    'INTEGRATED_CNC_SCHEMA.DIRECTION_SHAPE_REPRESENTATION' IN
    TYPEOF(pdr.used_representation)) AND (pdr.used_representation
    .name = 'row layout direction')) = 1))) = 0;
  WR3: SIZEOF(QUERY (pd <* USEDIN(SELf,
    'INTEGRATED_CNC_SCHEMA.PROPERTY_DEFINITION.DEFINITION')| NOT
    (SIZEOF(QUERY (pdr <* USEDIN(pd, 'INTEGRATED_CNC_SCHEMA.' +
    'PROPERTY_DEFINITION_REPRESENTATION.DEFINITION')| (
    'INTEGRATED_CNC_SCHEMA.DIRECTION_SHAPE_REPRESENTATION' IN
    TYPEOF(pdr.used_representation)) AND (pdr.used_representation
    .name = 'column layout direction')) = 1))) = 0;
  WR4: SIZEOF(QUERY (pd <* USEDIN(SELf,
    'INTEGRATED_CNC_SCHEMA.PROPERTY_DEFINITION.' + 'DEFINITION')|
    NOT (SIZEOF(QUERY (pdr <* USEDIN(pd,
    'INTEGRATED_CNC_SCHEMA.' +
    'PROPERTY_DEFINITION_REPRESENTATION.DEFINITION')| (
    'INTEGRATED_CNC_SCHEMA.' +
    'SHAPE_REPRESENTATION_WITH_PARAMETERS' IN TYPEOF(pdr.
    used_representation)))) = 1))) = 0;
  WR5: SIZEOF(QUERY (pd <* USEDIN(SELf,
    'INTEGRATED_CNC_SCHEMA.PROPERTY_DEFINITION.DEFINITION')| NOT
    (SIZEOF(QUERY (impl_rep <* QUERY (pdr <* USEDIN(pd,
    'INTEGRATED_CNC_SCHEMA.' +
    'PROPERTY_DEFINITION_REPRESENTATION.DEFINITION')| (
    'INTEGRATED_CNC_SCHEMA.' +
    'SHAPE_REPRESENTATION_WITH_PARAMETERS' IN TYPEOF(pdr.
    used_representation))))| NOT (SIZEOF(impl_rep.

```

```

used_representation.items) = 5))) = 0))) = 0;
WR6: SIZEOF(QUERY (pd <* USEDIN(SELF,
'INTEGRATED_CNC_SCHEMA.PROPERTY_DEFINITION.DEFINITION')| NOT
(SIZEOF(QUERY (impl_rep <* QUERY (pdr <* USEDIN(pd,
'INTEGRATED_CNC_SCHEMA.' +
'PROPERTY_DEFINITION_REPRESENTATION.DEFINITION')| (
'INTEGRATED_CNC_SCHEMA.' +
'SHAPE_REPRESENTATION_WITH_PARAMETERS' IN TYPEOF(pdr.
used_representation)))| NOT (SIZEOF(QUERY (it <* impl_rep.
used_representation.items| ((
'INTEGRATED_CNC_SCHEMA.MEASURE_REPRESENTATION_ITEM' IN TYPEOF
(it)) AND ('INTEGRATED_CNC_SCHEMA.COUNT_MEASURE' IN TYPEOF(it
\measure_with_unit.value_component))) AND (it.name =
'number of rows')))) = 1))) = 0))) = 0;
WR7: SIZEOF(QUERY (pd <* USEDIN(SELF,
'INTEGRATED_CNC_SCHEMA.PROPERTY_DEFINITION.DEFINITION')| NOT
(SIZEOF(QUERY (impl_rep <* QUERY (pdr <* USEDIN(pd,
'INTEGRATED_CNC_SCHEMA.' +
'PROPERTY_DEFINITION_REPRESENTATION.DEFINITION')| (
'INTEGRATED_CNC_SCHEMA.' +
'SHAPE_REPRESENTATION_WITH_PARAMETERS' IN TYPEOF(pdr.
used_representation)))| NOT (SIZEOF(QUERY (it <* impl_rep.
used_representation.items| ((
'INTEGRATED_CNC_SCHEMA.MEASURE_REPRESENTATION_ITEM' IN TYPEOF
(it)) AND ('INTEGRATED_CNC_SCHEMA.COUNT_MEASURE' IN TYPEOF(it
\measure_with_unit.value_component))) AND (it.name =
'number of columns')))) = 1))) = 0))) = 0;
WR8: SIZEOF(QUERY (pd <* USEDIN(SELF,
'INTEGRATED_CNC_SCHEMA.PROPERTY_DEFINITION.DEFINITION')| NOT
(SIZEOF(QUERY (impl_rep <* QUERY (pdr <* USEDIN(pd,
'INTEGRATED_CNC_SCHEMA.' +
'PROPERTY_DEFINITION_REPRESENTATION.DEFINITION')| (
'INTEGRATED_CNC_SCHEMA.' +
'SHAPE_REPRESENTATION_WITH_PARAMETERS' IN TYPEOF(pdr.
used_representation)))| NOT (SIZEOF(QUERY (it <* impl_rep.
used_representation.items| (SIZEOF([
'INTEGRATED_CNC_SCHEMA.MEASURE_REPRESENTATION_ITEM',
'INTEGRATED_CNC_SCHEMA.LENGTH_MEASURE_WITH_UNIT' ] * TYPEOF(
it)) = 2) AND (it.name = 'row spacing')))) = 1))) = 0))) = 0;
WR9: SIZEOF(QUERY (pd <* USEDIN(SELF,
'INTEGRATED_CNC_SCHEMA.PROPERTY_DEFINITION.DEFINITION')| NOT
(SIZEOF(QUERY (impl_rep <* QUERY (pdr <* USEDIN(pd,
'INTEGRATED_CNC_SCHEMA.' +
'PROPERTY_DEFINITION_REPRESENTATION.DEFINITION')| (
'INTEGRATED_CNC_SCHEMA.' +
'SHAPE_REPRESENTATION_WITH_PARAMETERS' IN TYPEOF(pdr.
used_representation)))| NOT (SIZEOF(QUERY (it <* impl_rep.
used_representation.items| (SIZEOF([
'INTEGRATED_CNC_SCHEMA.MEASURE_REPRESENTATION_ITEM',
'INTEGRATED_CNC_SCHEMA.LENGTH_MEASURE_WITH_UNIT' ] * TYPEOF(
it)) = 2) AND (it.name = 'column spacing')))) = 1))) = 0))) =
0;
WR10: SIZEOF(QUERY (pd <* USEDIN(SELF,
'INTEGRATED_CNC_SCHEMA.PROPERTY_DEFINITION.DEFINITION')| NOT

```

```

        (SIZEOF(QUERY (impl_rep <* QUERY (pdr <* USEDIN(pd,
        'INTEGRATED_CNC_SCHEMA.' +
        'PROPERTY_DEFINITION_REPRESENTATION.DEFINITION')| (
        'INTEGRATED_CNC_SCHEMA.' +
        'SHAPE_REPRESENTATION_WITH_PARAMETERS' IN TYPEOF(pdr.
        used_representation)))| NOT (SIZEOF(QUERY (it <* impl_rep.
        used_representation.items| ('INTEGRATED_CNC_SCHEMA.PLACEMENT'
        IN TYPEOF(it)) AND (it.name = 'orientation')) = 1))) = 0)))
        = 0;
END_ENTITY; -- 10303-522: aic_machining_feature

ENTITY rectangular_trimmed_surface
  SUBTYPE OF (bounded_surface);
  basis_surface : surface;
  u1             : parameter_value;
  u2             : parameter_value;
  v1             : parameter_value;
  v2             : parameter_value;
  usense        : BOOLEAN;
  vsense        : BOOLEAN;
  WHERE
    WR1: u1 <> u2;
    WR2: v1 <> v2;
    WR3: (('INTEGRATED_CNC_SCHEMA.ELEMENTARY_SURFACE' IN TYPEOF(
        basis_surface)) AND NOT ('INTEGRATED_CNC_SCHEMA.PLANE' IN
        TYPEOF(basis_surface)) OR (
        'INTEGRATED_CNC_SCHEMA.SURFACE_OF_REVOLUTION' IN TYPEOF(
        basis_surface))) OR (usense = (u2 > u1));
    WR4: (('INTEGRATED_CNC_SCHEMA.SPHERICAL_SURFACE' IN TYPEOF(
        basis_surface)) OR ('INTEGRATED_CNC_SCHEMA.TOROIDAL_SURFACE'
        IN TYPEOF(basis_surface))) OR (vsense = (v2 > v1));
END_ENTITY; -- 10303-42: geometry_schema

ENTITY referenced_modified_datum
  SUBTYPE OF (datum_reference);
  modifier : limit_condition;
END_ENTITY; -- 10303-47: shape_aspect_definition_schema

ENTITY removal_volume
  SUBTYPE OF (feature_definition);
  WHERE
    WR1: SIZEOF(QUERY (pd <* USEDIN(SELF,
        'INTEGRATED_CNC_SCHEMA.PROPERTY_DEFINITION.DEFINITION')| NOT
        (SIZEOF(QUERY (impl_rep <* QUERY (pdr <* USEDIN(pd,
        'INTEGRATED_CNC_SCHEMA.' +
        'PROPERTY_DEFINITION_REPRESENTATION.DEFINITION')| (
        'INTEGRATED_CNC_SCHEMA.' +
        'SHAPE_REPRESENTATION_WITH_PARAMETERS' IN TYPEOF(pdr.
        used_representation)))| NOT (SIZEOF(impl_rep.
        used_representation.items) = 1))) = 0))) = 0;
    WR2: SIZEOF(QUERY (pds <* QUERY (pd <* USEDIN(SELF,
        'INTEGRATED_CNC_SCHEMA.PROPERTY_DEFINITION.DEFINITION')| (
        'INTEGRATED_CNC_SCHEMA.PRODUCT_DEFINITION_SHAPE' IN TYPEOF(pd
        )))| NOT (SIZEOF(QUERY (sa_occ <* USEDIN(pds,

```

```

        'INTEGRATED_CNC_SCHEMA.SHAPE_ASPECT.OF_SHAPE')| (sa_occ.
description = 'shape volume occurrence') AND (SIZEOF(QUERY (
sdr <* QUERY (sar <* USEDIN(sa_occ,
'INTEGRATED_CNC_SCHEMA.SHAPE_ASPECT_RELATIONSHIP.' +
'RELATED_SHAPE_ASPECT')| (sar.description =
'volume shape usage') AND ('INTEGRATED_CNC_SCHEMA.' +
'SHAPE_DEFINING_RELATIONSHIP' IN TYPEOF(sar)))| (sdr.
relating_shape_aspect.description = 'volume shape')) = 1)))
= 1))) = 0;
END_ENTITY; -- 10303-522: aic_machining_feature

ENTITY reparametrised_composite_curve_segment
  SUBTYPE OF (composite_curve_segment);
  param_length : parameter_value;
  WHERE
    WR1: param_length > 0.0;
END_ENTITY; -- 10303-42: geometry_schema

ENTITY replicate_feature
  SUPERTYPE OF (ONEOF(circular_pattern, rectangular_pattern,
  feature_pattern))
  SUBTYPE OF (feature_definition);
  WHERE
    WR1: SIZEOF(QUERY (pd <* USEDIN(SELF,
      'INTEGRATED_CNC_SCHEMA.PROPERTY_DEFINITION.DEFINITION')| NOT
      (SIZEOF(QUERY (pdr <* USEDIN(pd, 'INTEGRATED_CNC_SCHEMA.' +
      'PROPERTY_DEFINITION_REPRESENTATION.DEFINITION')| (
      'INTEGRATED_CNC_SCHEMA.' +
      'SHAPE_REPRESENTATION_WITH_PARAMETERS' IN TYPEOF(pdr.
      used_representation)))) = 1))) = 0;
    WR2: SIZEOF(QUERY (fcr <* QUERY (sar <* USEDIN(SELF,
      'INTEGRATED_CNC_SCHEMA.SHAPE_ASPECT_RELATIONSHIP.' +
      'RELATING_SHAPE_ASPECT')| (
      'INTEGRATED_CNC_SCHEMA.FEATURE_COMPONENT_RELATIONSHIP' IN
      TYPEOF(sar)))| (SIZEOF([
      'INTEGRATED_CNC_SCHEMA.REPLICATE_FEATURE',
      'INTEGRATED_CNC_SCHEMA.INSTANCED_FEATURE' ] * TYPEOF(fcr.
      related_shape_aspect)) >= 1) AND (fcr.name = 'pattern basis')
      )) = 1;
    WR3: SIZEOF(QUERY (sar <* USEDIN(SELF,
      'INTEGRATED_CNC_SCHEMA.SHAPE_ASPECT_RELATIONSHIP.' +
      'RELATING_SHAPE_ASPECT')| NOT (
      'INTEGRATED_CNC_SCHEMA.FEATURE_COMPONENT_RELATIONSHIP' IN
      TYPEOF(sar))) + SIZEOF(QUERY (sar <* USEDIN(SELF,
      'INTEGRATED_CNC_SCHEMA.SHAPE_ASPECT_RELATIONSHIP.' +
      'RELATED_SHAPE_ASPECT')| NOT (
      'INTEGRATED_CNC_SCHEMA.FEATURE_COMPONENT_RELATIONSHIP' IN
      TYPEOF(sar)))) = 0;
END_ENTITY; -- 10303-522: aic_machining_feature

ENTITY representation;
  name : label;
  items : SET [1:?] OF representation_item;
  context_of_items : representation_context;

```

```

DERIVE
  id          : identifier := get_id_value(SELF);
  description : text      := get_description_value(SELF);
WHERE
  WR1: SIZEOF(USEDIN(SELF, 'INTEGRATED_CNC_SCHEMA.' +
    'ID_ATTRIBUTE.IDENTIFIED_ITEM')) <= 1;
  WR2: SIZEOF(USEDIN(SELF, 'INTEGRATED_CNC_SCHEMA.' +
    'DESCRIPTION_ATTRIBUTE.DESCRIBED_ITEM')) <= 1;
END_ENTITY; -- 10303-43: representation_schema

ENTITY representation_context;
  context_identifier : identifier;
  context_type       : text;
INVERSE
  representations_in_context : SET [1:?] OF representation FOR
    context_of_items;
END_ENTITY; -- 10303-43: representation_schema

ENTITY representation_item;
  name : label;
WHERE
  WR1: SIZEOF(using_representations(SELF)) > 0;
END_ENTITY; -- 10303-43: representation_schema

ENTITY representation_item_relationship;
  name          : label;
  description   : OPTIONAL text;
  relating_representation_item : representation_item;
  related_representation_item  : representation_item;
END_ENTITY; -- 10303-43: representation_schema

ENTITY representation_map;
  mapping_origin      : representation_item;
  mapped_representation : representation;
INVERSE
  map_usage : SET [1:?] OF mapped_item FOR mapping_source;
WHERE
  WR1: item_in_context(SELF.mapping_origin, SELF.mapped_representation.
    context_of_items);
END_ENTITY; -- 10303-43: representation_schema

ENTITY representation_relationship;
  name          : label;
  description   : OPTIONAL text;
  rep_1         : representation;
  rep_2         : representation;
END_ENTITY; -- 10303-43: representation_schema

ENTITY representation_relationship_with_transformation
  SUBTYPE OF (representation_relationship);
  transformation_operator : transformation;
WHERE
  WR1: SELF\representation_relationship.rep_1.context_of_items :<>: SELF\
    representation_relationship.rep_2.context_of_items;

```

```

END_ENTITY; -- 10303-43: representation_schema

ENTITY requirement_for_action_resource
  SUBTYPE OF (action_resource_requirement);
  resources : SET [1:?] OF action_resource;
END_ENTITY; -- 10303-49: process_property_schema

ENTITY resource_property;
  name      : label;
  description : text;
  resource   : characterized_resource_definition;
END_ENTITY; -- 10303-49: process_property_schema

ENTITY resource_property_representation;
  name      : label;
  description : text;
  property   : resource_property;
  representation : representation;
END_ENTITY; -- 10303-49: process_property_representation_schema

ENTITY resource_requirement_type;
  name      : label;
  description : text;
END_ENTITY; -- 10303-49: process_property_schema

ENTITY revolved_profile
  SUBTYPE OF (feature_definition);
  WHERE
    WR1: SELF\characterized_object.description IN [ 'groove', 'flat',
      'round', 'open profile' ];
    WR2: SIZEOF(QUERY (pd <* USEDIN(SELF,
      'INTEGRATED_CNC_SCHEMA.PROPERTY_DEFINITION.DEFINITION') | NOT
      (SIZEOF(QUERY (impl_rep <* QUERY (pdr <* USEDIN(pd,
      'INTEGRATED_CNC_SCHEMA.' +
      'PROPERTY_DEFINITION_REPRESENTATION.DEFINITION') | (
      'INTEGRATED_CNC_SCHEMA.' +
      'SHAPE_REPRESENTATION_WITH_PARAMETERS' IN TYPEOF(pdr.
      used_representation)))) | NOT (SIZEOF(impl_rep.
      used_representation.items) = 2))) = 0))) = 0;
    WR3: SIZEOF(QUERY (pd <* USEDIN(SELF,
      'INTEGRATED_CNC_SCHEMA.PROPERTY_DEFINITION.DEFINITION') | NOT
      (SIZEOF(QUERY (impl_rep <* QUERY (pdr <* USEDIN(pd,
      'INTEGRATED_CNC_SCHEMA.' +
      'PROPERTY_DEFINITION_REPRESENTATION.DEFINITION') | (
      'INTEGRATED_CNC_SCHEMA.' +
      'SHAPE_REPRESENTATION_WITH_PARAMETERS' IN TYPEOF(pdr.
      used_representation)))) | NOT (SIZEOF(QUERY (it <* impl_rep.
      used_representation.items | (SIZEOF([
      'INTEGRATED_CNC_SCHEMA.MEASURE_REPRESENTATION_ITEM',
      'INTEGRATED_CNC_SCHEMA.LENGTH_MEASURE_WITH_UNIT' ] * TYPEOF(
      it)) = 2) AND (it.name = 'radius')) = 1))) = 0))) = 0;
    WR4: SIZEOF(QUERY (pdr <* get_property_definition_representations(SELF)
      | ('INTEGRATED_CNC_SCHEMA.DIRECTION_SHAPE_REPRESENTATION' IN
      TYPEOF(pdr.used_representation)) AND (pdr.used_representation

```



```

.name = 'removal direction')) = 1;
WR5: NOT (SELF\characterized_object.description = 'open profile') OR (
  SIZEOF(QUERY (pds <* QUERY (pd <* USEDIN(SELF,
    'INTEGRATED_CNC_SCHEMA.PROPERTY_DEFINITION.DEFINITION') | (
    'INTEGRATED_CNC_SCHEMA.PRODUCT_DEFINITION_SHAPE' IN TYPEOF(pd
  ))) | NOT (SIZEOF(QUERY (sa_occ <* USEDIN(pds,
    'INTEGRATED_CNC_SCHEMA.SHAPE_ASPECT.OF_SHAPE') | (sa_occ.
    description = 'outer edge shape occurrence') AND (SIZEOF(
    QUERY (sdr <* QUERY (sar <* USEDIN(sa_occ,
    'INTEGRATED_CNC_SCHEMA.SHAPE_ASPECT_RELATIONSHIP.' +
    'RELATED_SHAPE_ASPECT') | (sar.description = 'profile usage')
    AND ('INTEGRATED_CNC_SCHEMA.SHAPE_DEFINING_RELATIONSHIP' IN
    TYPEOF(sar))) | ('INTEGRATED_CNC_SCHEMA.OPEN_PATH_PROFILE' IN
    TYPEOF(sdr.relying_shape_aspect)) AND (sdr.
    relating_shape_aspect.description = 'outer edge shape')))) = 1
  ))) = 0);
WR6: NOT (SELF\characterized_object.description = 'flat') OR (SIZEOF(
  QUERY (pds <* QUERY (pd <* USEDIN(SELF,
    'INTEGRATED_CNC_SCHEMA.PROPERTY_DEFINITION.DEFINITION') | (
    'INTEGRATED_CNC_SCHEMA.PRODUCT_DEFINITION_SHAPE' IN TYPEOF(pd
  ))) | NOT (SIZEOF(QUERY (sa_occ <* USEDIN(pds,
    'INTEGRATED_CNC_SCHEMA.SHAPE_ASPECT.OF_SHAPE') | (sa_occ.
    description = 'flat edge shape occurrence') AND (SIZEOF(QUERY
    (sdr <* QUERY (sar <* USEDIN(sa_occ,
    'INTEGRATED_CNC_SCHEMA.SHAPE_ASPECT_RELATIONSHIP.' +
    'RELATED_SHAPE_ASPECT') | (sar.description = 'profile usage')
    AND ('INTEGRATED_CNC_SCHEMA.SHAPE_DEFINING_RELATIONSHIP' IN
    TYPEOF(sar))) | ('INTEGRATED_CNC_SCHEMA.LINEAR_PROFILE' IN
    TYPEOF(sdr.relying_shape_aspect)) AND (sdr.
    relating_shape_aspect.description = 'flat edge shape')))) = 1
  ))) = 0);
WR7: NOT (SELF\characterized_object.description = 'round') OR (SIZEOF(
  QUERY (pds <* QUERY (pd <* USEDIN(SELF,
    'INTEGRATED_CNC_SCHEMA.PROPERTY_DEFINITION.DEFINITION') | (
    'INTEGRATED_CNC_SCHEMA.PRODUCT_DEFINITION_SHAPE' IN TYPEOF(pd
  ))) | NOT (SIZEOF(QUERY (sa_occ <* USEDIN(pds,
    'INTEGRATED_CNC_SCHEMA.SHAPE_ASPECT.OF_SHAPE') | (sa_occ.
    description = 'rounded edge shape occurrence') AND (SIZEOF(
    QUERY (sdr <* QUERY (sar <* USEDIN(sa_occ,
    'INTEGRATED_CNC_SCHEMA.SHAPE_ASPECT_RELATIONSHIP.' +
    'RELATED_SHAPE_ASPECT') | (sar.description = 'profile usage')
    AND ('INTEGRATED_CNC_SCHEMA.SHAPE_DEFINING_RELATIONSHIP' IN
    TYPEOF(sar))) | (
    'INTEGRATED_CNC_SCHEMA.PARTIAL_CIRCULAR_PROFILE' IN TYPEOF(
    sdr.relying_shape_aspect)) AND (sdr.relying_shape_aspect.
    description = 'rounded edge shape')))) = 1))) = 0);
WR8: NOT (SELF\characterized_object.description = 'groove') OR (SIZEOF(
  QUERY (pds <* QUERY (pd <* USEDIN(SELF,
    'INTEGRATED_CNC_SCHEMA.PROPERTY_DEFINITION.DEFINITION') | (
    'INTEGRATED_CNC_SCHEMA.PRODUCT_DEFINITION_SHAPE' IN TYPEOF(pd
  ))) | NOT (SIZEOF(QUERY (sa_occ <* USEDIN(pds,
    'INTEGRATED_CNC_SCHEMA.SHAPE_ASPECT.OF_SHAPE') | (sa_occ.
    description = 'sweep occurrence') AND (SIZEOF(QUERY (sdr <*
    QUERY (sar <* USEDIN(sa_occ,

```

```

        'INTEGRATED_CNC_SCHEMA.SHAPE_ASPECT_RELATIONSHIP.' +
        'RELATED_SHAPE_ASPECT')| (sar.description = 'profile usage')
AND ('INTEGRATED_CNC_SCHEMA.SHAPE_DEFINING_RELATIONSHIP' IN
TYPEOF(sar))| (SIZEOF([
        'INTEGRATED_CNC_SCHEMA.SQUARE_U_PROFILE',
        'INTEGRATED_CNC_SCHEMA.PARTIAL_CIRCULAR_PROFILE',
        'INTEGRATED_CNC_SCHEMA.ROUNDED_U_PROFILE',
        'INTEGRATED_CNC_SCHEMA.VEE_PROFILE',
        'INTEGRATED_CNC_SCHEMA.TEE_PROFILE',
        'INTEGRATED_CNC_SCHEMA.OPEN_PATH_PROFILE' ] * TYPEOF(sdr.
relating_shape_aspect)) = 1) AND (sdr.relating_shape_aspect.
description = 'sweep')) = 1))) = 1))) = 0);
    WR9: SIZEOF(QUERY (pdr <* get_property_definition_representations(SELF)
| ('INTEGRATED_CNC_SCHEMA.PLANAR_SHAPE_REPRESENTATION' IN
TYPEOF(pdr.used_representation)) AND (pdr.used_representation
.name = 'maximum feature limit')) >= 0;
END_ENTITY; -- 10303-522: aic_machining_feature

```

```

ENTITY rib_top
  SUBTYPE OF (feature_definition);
  WHERE
    WR1: SIZEOF(QUERY (pds <* QUERY (pd <* USEDIN(SELF,
        'INTEGRATED_CNC_SCHEMA.PROPERTY_DEFINITION.DEFINITION')| (
        'INTEGRATED_CNC_SCHEMA.PRODUCT_DEFINITION_SHAPE' IN TYPEOF(pd
        )))| NOT (SIZEOF(QUERY (sa_occ <* USEDIN(pds,
        'INTEGRATED_CNC_SCHEMA.SHAPE_ASPECT.OF_SHAPE')| (sa_occ.
description = 'rib top condition occurrence') AND (SIZEOF(
QUERY (sdr <* QUERY (sar <* USEDIN(sa_occ,
        'INTEGRATED_CNC_SCHEMA.SHAPE_ASPECT_RELATIONSHIP.' +
        'RELATED_SHAPE_ASPECT')| (sar.description = 'rib top usage')
AND ('INTEGRATED_CNC_SCHEMA.FEATURE_COMPONENT_RELATIONSHIP'
IN TYPEOF(sar))| ('INTEGRATED_CNC_SCHEMA.RIB_TOP_FLOOR' IN
TYPEOF(sdr.relating_shape_aspect)) AND (
        'INTEGRATED_CNC_SCHEMA.RIB_TOP' IN TYPEOF(sdr.
related_shape_aspect.of_shape.definition)))) = 1))) = 1))) =
0;
    WR2: SIZEOF(QUERY (pd <* USEDIN(SELF,
        'INTEGRATED_CNC_SCHEMA.PROPERTY_DEFINITION.DEFINITION')| NOT
(SIZEOF(QUERY (pdr <* USEDIN(pd, 'INTEGRATED_CNC_SCHEMA.' +
        'PROPERTY_DEFINITION_REPRESENTATION.DEFINITION')| (
        'INTEGRATED_CNC_SCHEMA.DIRECTION_SHAPE_REPRESENTATION' IN
TYPEOF(pdr.used_representation)) AND (pdr.used_representation
.name = 'removal direction')) = 1))) = 1);
    WR3: SIZEOF(QUERY (pdr <* get_property_definition_representations(SELF)
| ('INTEGRATED_CNC_SCHEMA.PLANAR_SHAPE_REPRESENTATION' IN
TYPEOF(pdr.used_representation)) AND (pdr.used_representation
.name = 'maximum feature limit')) >= 0;
END_ENTITY; -- 10303-522: aic_machining_feature

```

```

ENTITY rib_top_floor
  SUBTYPE OF (shape_aspect);
  WHERE
    WR1: 'INTEGRATED_CNC_SCHEMA.FEATURE_COMPONENT_DEFINITION' IN TYPEOF(
        SELF.of_shape.definition);

```

```

WR2: SELF.description IN [ 'planar', 'complex' ];
WR3: SIZEOF(QUERY (fcr <* QUERY (sar <* USEDIN(SELF,
  'INTEGRATED_CNC_SCHEMA.SHAPE_ASPECT_RELATIONSHIP.' +
  'RELATING_SHAPE_ASPECT')| (sar.description = 'rib top usage')
  AND ('INTEGRATED_CNC_SCHEMA.FEATURE_COMPONENT_RELATIONSHIP'
  IN TYPEOF(sar)))| ((fcr.related_shape_aspect.description =
  'rib top condition occurrence') AND (
  'INTEGRATED_CNC_SCHEMA.RIB_TOP' IN TYPEOF(fcr.
  related_shape_aspect.of_shape.definition))) AND (
  'INTEGRATED_CNC_SCHEMA.RIB_TOP_FLOOR' IN TYPEOF(fcr.
  relating_shape_aspect)))) >= 1;
WR4: NOT (SELF.description = 'complex') OR (SIZEOF(QUERY (pd <* USEDIN(
  SELF, 'INTEGRATED_CNC_SCHEMA.PROPERTY_DEFINITION.DEFINITION')
  | NOT (SIZEOF(QUERY (pdr <* USEDIN(pd,
  'INTEGRATED_CNC_SCHEMA.' +
  'PROPERTY_DEFINITION_REPRESENTATION.DEFINITION')| (
  'INTEGRATED_CNC_SCHEMA.FACE_SHAPE_REPRESENTATION' IN TYPEOF(
  pdr.used_representation)) AND (pdr.used_representation.name =
  'rib top face')) = 1))) = 0);
WR5: NOT (SELF.description = 'planar') OR (SIZEOF(QUERY (pd <* USEDIN(
  SELF, 'INTEGRATED_CNC_SCHEMA.PROPERTY_DEFINITION.DEFINITION')
  | NOT (SIZEOF(QUERY (pdr <* USEDIN(pd,
  'INTEGRATED_CNC_SCHEMA.' +
  'PROPERTY_DEFINITION_REPRESENTATION.DEFINITION')| (
  'INTEGRATED_CNC_SCHEMA.PLANAR_SHAPE_REPRESENTATION' IN TYPEOF(
  pdr.used_representation)) AND (pdr.used_representation.name
  = 'rib top face')) = 1))) = 0);
WR6: NOT (SELF.description = 'planar') OR (SIZEOF(QUERY (pds <* QUERY (
  pd <* USEDIN(SELF,
  'INTEGRATED_CNC_SCHEMA.PROPERTY_DEFINITION.DEFINITION')| (
  'INTEGRATED_CNC_SCHEMA.PRODUCT_DEFINITION_SHAPE' IN TYPEOF(pd
  )))| NOT (SIZEOF(QUERY (sa_occ <* USEDIN(pds,
  'INTEGRATED_CNC_SCHEMA.SHAPE_ASPECT.OF_SHAPE')| (sa_occ.
  description = 'boundary occurrence') AND (SIZEOF(QUERY (sdr
  <* QUERY (sar <* USEDIN(sa_occ,
  'INTEGRATED_CNC_SCHEMA.SHAPE_ASPECT_RELATIONSHIP.' +
  'RELATED_SHAPE_ASPECT')| (sar.description = 'profile usage')
  AND ('INTEGRATED_CNC_SCHEMA.SHAPE_DEFINING_RELATIONSHIP' IN
  TYPEOF(sar)))| (SIZEOF([
  'INTEGRATED_CNC_SCHEMA.CIRCULAR_CLOSED_PROFILE',
  'INTEGRATED_CNC_SCHEMA.NGON_CLOSED_PROFILE',
  'INTEGRATED_CNC_SCHEMA.RECTANGULAR_CLOSED_PROFILE',
  'INTEGRATED_CNC_SCHEMA.CLOSED_PATH_PROFILE' ] * TYPEOF(sdr.
  relating_shape_aspect)) = 1) AND (sdr.relatating_shape_aspect.
  description = 'rib top floor boundary')) = 1))) = 1))) = 0);
END_ENTITY; -- 10303-522: aic_machining_feature

ENTITY right_circular_cylinder
  SUBTYPE OF (geometric_representation_item);
  position : axis1_placement;
  height   : positive_length_measure;
  radius   : positive_length_measure;
END_ENTITY; -- 10303-42: geometric_model_schema

```

```

ENTITY role_association;
    role          : object_role;
    item_with_role : role_select;
END_ENTITY; -- 10303-41: basic_attribute_schema

ENTITY round_hole
    SUBTYPE OF (feature_definition);
    WHERE
        WR1: SIZEOF(QUERY (pds <* QUERY (pd <* USEDIN(SELF,
            'INTEGRATED_CNC_SCHEMA.PROPERTY_DEFINITION.DEFINITION') | (
            'INTEGRATED_CNC_SCHEMA.PRODUCT_DEFINITION_SHAPE' IN TYPEOF(pd
            ))) | NOT (SIZEOF(QUERY (sa_occ <* USEDIN(pds,
            'INTEGRATED_CNC_SCHEMA.SHAPE_ASPECT.OF_SHAPE') | (sa_occ.
            description = 'diameter occurrence') AND (SIZEOF(QUERY (sdr
            <* QUERY (sar <* USEDIN(sa_occ,
            'INTEGRATED_CNC_SCHEMA.SHAPE_ASPECT_RELATIONSHIP.' +
            'RELATED_SHAPE_ASPECT') | (sar.description = 'profile usage')
            AND ('INTEGRATED_CNC_SCHEMA.SHAPE_DEFINING_RELATIONSHIP' IN
            TYPEOF(sar))) | (
            'INTEGRATED_CNC_SCHEMA.CIRCULAR_CLOSED_PROFILE' IN TYPEOF(sdr
            .relating_shape_aspect)) AND (sdr.name = 'diameter')))) = 1))) =
            1))) = 0;
        WR2: SIZEOF(QUERY (pds <* QUERY (pd <* USEDIN(SELF,
            'INTEGRATED_CNC_SCHEMA.PROPERTY_DEFINITION.DEFINITION') | (
            'INTEGRATED_CNC_SCHEMA.PRODUCT_DEFINITION_SHAPE' IN TYPEOF(pd
            ))) | NOT (SIZEOF(QUERY (sa_occ <* USEDIN(pds,
            'INTEGRATED_CNC_SCHEMA.SHAPE_ASPECT.OF_SHAPE') | (sa_occ.
            description = 'hole depth occurrence') AND (SIZEOF(QUERY (sdr
            <* QUERY (sar <* USEDIN(sa_occ,
            'INTEGRATED_CNC_SCHEMA.SHAPE_ASPECT_RELATIONSHIP.' +
            'RELATED_SHAPE_ASPECT') | (sar.description =
            'path feature component usage') AND (
            'INTEGRATED_CNC_SCHEMA.SHAPE_DEFINING_RELATIONSHIP' IN TYPEOF
            (sar))) | (('INTEGRATED_CNC_SCHEMA.PATH_FEATURE_COMPONENT' IN
            TYPEOF(sdr.relating_shape_aspect)) AND (sdr.name =
            'hole depth')) AND (sdr.relating_shape_aspect.description =
            'linear')))) = 1))) = 1))) = 0;
        WR3: SIZEOF(QUERY (pds <* QUERY (pd <* USEDIN(SELF,
            'INTEGRATED_CNC_SCHEMA.PROPERTY_DEFINITION.DEFINITION') | (
            'INTEGRATED_CNC_SCHEMA.PRODUCT_DEFINITION_SHAPE' IN TYPEOF(pd
            ))) | NOT (SIZEOF(QUERY (sa_occ <* USEDIN(pds,
            'INTEGRATED_CNC_SCHEMA.SHAPE_ASPECT.OF_SHAPE') | (sa_occ.
            description = 'bottom condition occurrence') AND (SIZEOF(
            QUERY (fcr <* QUERY (sar <* USEDIN(sa_occ,
            'INTEGRATED_CNC_SCHEMA.SHAPE_ASPECT_RELATIONSHIP.' +
            'RELATED_SHAPE_ASPECT') | (sar.description =
            'hole bottom usage') AND (
            'INTEGRATED_CNC_SCHEMA.FEATURE_COMPONENT_RELATIONSHIP' IN
            TYPEOF(sar))) | ('INTEGRATED_CNC_SCHEMA.HOLE_BOTTOM' IN TYPEOF
            (fcr.relating_shape_aspect)) AND (
            'INTEGRATED_CNC_SCHEMA.ROUND_HOLE' IN TYPEOF(fcr.
            related_shape_aspect.of_shape.definition)))))) = 1))) = 1))) =
            0;
        WR4: SIZEOF(QUERY (pds <* QUERY (pd <* USEDIN(SELF,

```

```

'INTEGRATED_CNC_SCHEMA.PROPERTY_DEFINITION.DEFINITION')| (
'INTEGRATED_CNC_SCHEMA.PRODUCT_DEFINITION_SHAPE' IN TYPEOF(pd
)))| NOT (SIZEOF(QUERY (sa_occ <* USEDIN(pds,
'INTEGRATED_CNC_SCHEMA.SHAPE_ASPECT.OF_SHAPE')| (sa_occ.
description = 'change in diameter occurrence') AND (SIZEOF(
QUERY (fcr <* QUERY (sar <* USEDIN(sa_occ,
'INTEGRATED_CNC_SCHEMA.SHAPE_ASPECT_RELATIONSHIP.' +
'RELATED_SHAPE_ASPECT')| (sar.description = 'taper usage')
AND ('INTEGRATED_CNC_SCHEMA.FEATURE_COMPONENT_RELATIONSHIP'
IN TYPEOF(sar))))| ('INTEGRATED_CNC_SCHEMA.TAPER' IN TYPEOF(
fcr.relating_shape_aspect)) AND (
'INTEGRATED_CNC_SCHEMA.ROUND_HOLE' IN TYPEOF(fcr.
related_shape_aspect.of_shape.definition)))) = 1))) <= 1))) =
0;
WR5: SIZEOF(QUERY (pdr <* get_property_definition_representations(SELF)
| (
'INTEGRATED_CNC_SCHEMA.SHAPE_REPRESENTATION_WITH_PARAMETERS'
IN TYPEOF(pdr.used_representation)))) = 1;
END_ENTITY; -- 10303-522: aic_machining_feature

ENTITY rounded_end
SUBTYPE OF (feature_definition);
WHERE
WR1: SIZEOF(QUERY (pd <* USEDIN(SELF,
'INTEGRATED_CNC_SCHEMA.PROPERTY_DEFINITION.DEFINITION')| NOT
(SIZEOF(QUERY (impl_rep <* QUERY (pdr <* USEDIN(pd,
'INTEGRATED_CNC_SCHEMA.' +
'PROPERTY_DEFINITION_REPRESENTATION.DEFINITION')| (
'INTEGRATED_CNC_SCHEMA.' +
'SHAPE_REPRESENTATION_WITH_PARAMETERS' IN TYPEOF(pdr.
used_representation))))| NOT (SIZEOF(impl_rep.
used_representation.items) = 1))) = 0))) = 0;
WR2: SIZEOF(QUERY (pds <* QUERY (pd <* USEDIN(SELF,
'INTEGRATED_CNC_SCHEMA.PROPERTY_DEFINITION.DEFINITION')| (
'INTEGRATED_CNC_SCHEMA.PRODUCT_DEFINITION_SHAPE' IN TYPEOF(pd
)))| NOT (SIZEOF(QUERY (sa_occ <* USEDIN(pds,
'INTEGRATED_CNC_SCHEMA.SHAPE_ASPECT.OF_SHAPE')| (sa_occ.
description = 'partial circular boundary occurrence') AND (
SIZEOF(QUERY (sdr <* QUERY (sar <* USEDIN(sa_occ,
'INTEGRATED_CNC_SCHEMA.SHAPE_ASPECT_RELATIONSHIP.' +
'RELATED_SHAPE_ASPECT')| (sar.description = 'profile usage')
AND ('INTEGRATED_CNC_SCHEMA.SHAPE_DEFINING_RELATIONSHIP' IN
TYPEOF(sar))))| (
'INTEGRATED_CNC_SCHEMA.PARTIAL_CIRCULAR_PROFILE' IN TYPEOF(
sdr.relating_shape_aspect)))) = 1))) = 1))) = 0;
WR3: SIZEOF(QUERY (pds <* QUERY (pd <* USEDIN(SELF,
'INTEGRATED_CNC_SCHEMA.PROPERTY_DEFINITION.DEFINITION')| (
'INTEGRATED_CNC_SCHEMA.PRODUCT_DEFINITION_SHAPE' IN TYPEOF(pd
)))| NOT (SIZEOF(QUERY (sa_occ <* USEDIN(pds,
'INTEGRATED_CNC_SCHEMA.SHAPE_ASPECT.OF_SHAPE')| (sa_occ.
description = 'course of travel occurrence') AND (SIZEOF(
QUERY (sdr <* QUERY (sar <* USEDIN(sa_occ,
'INTEGRATED_CNC_SCHEMA.SHAPE_ASPECT_RELATIONSHIP.' +
'RELATED_SHAPE_ASPECT')| (sar.description =

```

```

        'path feature component usage') AND (
        'INTEGRATED_CNC_SCHEMA.SHAPE_DEFINING_RELATIONSHIP' IN TYPEOF
        (sar))) | ('INTEGRATED_CNC_SCHEMA.PATH_FEATURE_COMPONENT' IN
        TYPEOF(sdr.relatng_shape_aspect)) AND (sdr.
        relating_shape_aspect.description = 'linear')) = 1))) = 1)))
        = 0;
    WR4: SIZEOF(QUERY (pdr <* get_property_definition_representations(SELF)
        | ('INTEGRATED_CNC_SCHEMA.PLANAR_SHAPE_REPRESENTATION' IN
        TYPEOF(pdr.used_representation)) AND (pdr.used_representation
        .name = 'maximum feature limit')) >= 0;
END_ENTITY; -- 10303-522: aic_machining_feature

```

ENTITY rounded\_u\_profile

SUBTYPE OF (shape\_aspect);

WHERE

```

    WR1: 'INTEGRATED_CNC_SCHEMA.FEATURE_COMPONENT_DEFINITION' IN TYPEOF(
        SELF.of_shape.definition);
    WR2: SIZEOF(QUERY (pd <* USEDIN(SELF,
        'INTEGRATED_CNC_SCHEMA.PROPERTY_DEFINITION.DEFINITION') | NOT
        (SIZEOF(QUERY (pdr <* USEDIN(pd, 'INTEGRATED_CNC_SCHEMA.' +
        'PROPERTY_DEFINITION_REPRESENTATION.DEFINITION') | (
        'INTEGRATED_CNC_SCHEMA.' +
        'SHAPE_REPRESENTATION_WITH_PARAMETERS' IN TYPEOF(pdr.
        used_representation)))) = 1))) = 0;
    WR3: SIZEOF(QUERY (pd <* USEDIN(SELF,
        'INTEGRATED_CNC_SCHEMA.PROPERTY_DEFINITION.DEFINITION') | NOT
        (SIZEOF(QUERY (impl_rep <* QUERY (pdr <* USEDIN(pd,
        'INTEGRATED_CNC_SCHEMA.' +
        'PROPERTY_DEFINITION_REPRESENTATION.DEFINITION') | (
        'INTEGRATED_CNC_SCHEMA.' +
        'SHAPE_REPRESENTATION_WITH_PARAMETERS' IN TYPEOF(pdr.
        used_representation))) | NOT (SIZEOF(impl_rep.
        used_representation.items) >= 1) AND (SIZEOF(impl_rep.
        used_representation.items) <= 2))) = 0))) = 0;
    WR4: SIZEOF(QUERY (pd <* USEDIN(SELF,
        'INTEGRATED_CNC_SCHEMA.PROPERTY_DEFINITION.DEFINITION') | (
        SIZEOF(QUERY (pdr <* USEDIN(pd, 'INTEGRATED_CNC_SCHEMA.' +
        'PROPERTY_DEFINITION_REPRESENTATION.DEFINITION') | (
        'INTEGRATED_CNC_SCHEMA.' +
        'SHAPE_REPRESENTATION_WITH_PARAMETERS' IN TYPEOF(pdr.
        used_representation)) AND (SIZEOF(QUERY (srwp_i <* pdr.
        used_representation.items | (srwp_i.name = 'orientation') OR (
        srwp_i.name = 'depth')) = SIZEOF(pdr.used_representation.
        items)))) = 1))) = 1;
    WR5: SIZEOF(QUERY (pd <* USEDIN(SELF,
        'INTEGRATED_CNC_SCHEMA.PROPERTY_DEFINITION.DEFINITION') | NOT
        (SIZEOF(QUERY (impl_rep <* QUERY (pdr <* USEDIN(pd,
        'INTEGRATED_CNC_SCHEMA.' +
        'PROPERTY_DEFINITION_REPRESENTATION.DEFINITION') | (
        'INTEGRATED_CNC_SCHEMA.' +
        'SHAPE_REPRESENTATION_WITH_PARAMETERS' IN TYPEOF(pdr.
        used_representation))) | NOT (SIZEOF(QUERY (it <* impl_rep.
        used_representation.items | (SIZEOF([
        'INTEGRATED_CNC_SCHEMA.MEASURE_REPRESENTATION_ITEM',

```

```

        'INTEGRATED_CNC_SCHEMA.LENGTH_MEASURE_WITH_UNIT' ] * TYPEOF(
        it)) = 2) AND (it.name = 'width')) = 1))) = 0))) = 0;
WR6: SIZEOF(QUERY (pd <* USEDIN(SELF,
        'INTEGRATED_CNC_SCHEMA.PROPERTY_DEFINITION.DEFINITION')| NOT
        (SIZEOF(QUERY (pdr <* USEDIN(pd, 'INTEGRATED_CNC_SCHEMA.' +
        'PROPERTY_DEFINITION_REPRESENTATION.DEFINITION')| (
        'INTEGRATED_CNC_SCHEMA.PLANAR_SHAPE_REPRESENTATION' IN TYPEOF
        (pdr.used_representation)) AND (pdr.used_representation.name
        = 'profile limit')) <= 1))) = 0;
WR7: SIZEOF(QUERY (pd <* USEDIN(SELF,
        'INTEGRATED_CNC_SCHEMA.PROPERTY_DEFINITION.DEFINITION')| NOT
        (SIZEOF(QUERY (impl_rep <* QUERY (pdr <* USEDIN(pd,
        'INTEGRATED_CNC_SCHEMA.' +
        'PROPERTY_DEFINITION_REPRESENTATION.DEFINITION')| (
        'INTEGRATED_CNC_SCHEMA.' +
        'SHAPE_REPRESENTATION_WITH_PARAMETERS' IN TYPEOF(pdr.
        used_representation)))| NOT (SIZEOF(QUERY (it <* impl_rep.
        used_representation.items| (SIZEOF([
        'INTEGRATED_CNC_SCHEMA.MEASURE_REPRESENTATION_ITEM',
        'INTEGRATED_CNC_SCHEMA.LENGTH_MEASURE_WITH_UNIT' ] * TYPEOF(
        it)) = 2) AND (it.name = 'depth')) <= 1))) = 0))) = 0;
END_ENTITY; -- 10303-522: aic_machining_feature

ENTITY roundness_tolerance
  SUBTYPE OF (geometric_tolerance);
  WHERE
    WR1: NOT ('INTEGRATED_CNC_SCHEMA.' +
              'GEOMETRIC_TOLERANCE_WITH_DATUM_REFERENCE' IN TYPEOF(SELF));
END_ENTITY; -- 10303-519: aic_geometric_tolerances

ENTITY runout_zone_definition
  SUBTYPE OF (tolerance_zone_definition);
  orientation : runout_zone_orientation;
END_ENTITY; -- 10303-47: shape_tolerance_schema

ENTITY runout_zone_orientation;
  angle : measure_with_unit;
END_ENTITY; -- 10303-47: shape_tolerance_schema

ENTITY runout_zone_orientation_reference_direction
  SUBTYPE OF (runout_zone_orientation);
  orientation_defining_relationship : shape_aspect_relationship;
END_ENTITY; -- 10303-47: shape_tolerance_schema

ENTITY seam_curve
  SUBTYPE OF (surface_curve);
  WHERE
    WR1: SIZEOF(SELF\surface_curve.associated_geometry) = 2;
    WR2: associated_surface(SELF\surface_curve.associated_geometry[1]) =
          associated_surface(SELF\surface_curve.associated_geometry[2])
          ;
    WR3: 'INTEGRATED_CNC_SCHEMA.PCURVE' IN TYPEOF(SELF\surface_curve.
          associated_geometry[1]);
    WR4: 'INTEGRATED_CNC_SCHEMA.PCURVE' IN TYPEOF(SELF\surface_curve.

```

```

        associated_geometry[2]);
END_ENTITY; -- 10303-42: geometry_schema

ENTITY security_classification;
    name          : label;
    purpose       : text;
    security_level : security_classification_level;
END_ENTITY; -- 10303-41: security_classification_schema

ENTITY security_classification_assignment
    ABSTRACT SUPERTYPE;
    assigned_security_classification : security_classification;
    DERIVE
        role : object_role := get_role(SELF);
    WHERE
        WR1: SIZEOF(USEDIN(SELF, 'INTEGRATED_CNC_SCHEMA.' +
            'ROLE_ASSOCIATION.ITEM_WITH_ROLE')) <= 1;
END_ENTITY; -- 10303-41: management_resources_schema

ENTITY security_classification_level;
    name : label;
END_ENTITY; -- 10303-41: security_classification_schema

ENTITY sequential_method
    SUBTYPE OF (serial_action_method);
    sequence_position : count_measure;
END_ENTITY; -- 10303-49: method_definition_schema

ENTITY serial_action_method
    SUBTYPE OF (action_method_relationship);
END_ENTITY; -- 10303-49: method_definition_schema

ENTITY shape_aspect;
    name          : label;
    description   : OPTIONAL text;
    of_shape      : product_definition_shape;
    product_definitional : LOGICAL;
    DERIVE
        id : identifier := get_id_value(SELF);
    WHERE
        WR1: SIZEOF(USEDIN(SELF, 'INTEGRATED_CNC_SCHEMA.' +
            'ID_ATTRIBUTE.IDENTIFIED_ITEM')) <= 1;
END_ENTITY; -- 10303-41: product_property_definition_schema

ENTITY shape_aspect_deriving_relationship
    SUBTYPE OF (shape_aspect_relationship);
    WHERE
        WR1: 'INTEGRATED_CNC_SCHEMA.DERIVED_SHAPE_ASPECT' IN TYPEOF(SELF\
            shape_aspect_relationship.relate_shape_aspect);
END_ENTITY; -- 10303-47: shape_aspect_definition_schema

ENTITY shape_aspect_relationship;
    name          : label;
    description   : OPTIONAL text;

```



```

    relating_shape_aspect : shape_aspect;
    related_shape_aspect  : shape_aspect;
DERIVE
    id : identifier := get_id_value(SELf);
WHERE
    WR1: SIZEOF(USEDIN(SELf, 'INTEGRATED_CNC_SCHEMA.' +
        'ID_ATTRIBUTE.IDENTIFIED_ITEM')) <= 1;
END_ENTITY; -- 10303-41: product_property_definition_schema

ENTITY shape_defining_relationship
    SUBTYPE OF (shape_aspect_relationship);
END_ENTITY; -- 10303-522: aic_machining_feature

ENTITY shape_definition_representation
    SUBTYPE OF (property_definition_representation);
WHERE
    WR1: ('INTEGRATED_CNC_SCHEMA.PRODUCT_DEFINITION_SHAPE' IN TYPEOF(SELf.
        definition)) OR ('INTEGRATED_CNC_SCHEMA.SHAPE_DEFINITION' IN
        TYPEOF(SELf.definition.definition));
    WR2: 'INTEGRATED_CNC_SCHEMA.SHAPE_REPRESENTATION' IN TYPEOF(SELf.
        used_representation);
END_ENTITY; -- 10303-41: product_property_representation_schema

ENTITY shape_dimension_representation
    SUBTYPE OF (shape_representation);
WHERE
    WR1: SIZEOF(QUERY (temp <* SELf\representation.items| NOT (
        'INTEGRATED_CNC_SCHEMA.MEASURE_REPRESENTATION_ITEM' IN TYPEOF
        (temp)))) = 0;
    WR2: SIZEOF(SELf\representation.items) <= 3;
    WR3: SIZEOF(QUERY (pos_mri <* QUERY (real_mri <* SELf\representation.
        items| ('REAL' IN TYPEOF(real_mri\measure_with_unit.
        value_component)))| NOT (pos_mri\measure_with_unit.
        value_component > 0.0))) = 0;
END_ENTITY; -- 10303-47: shape_dimension_schema

ENTITY shape_representation
    SUBTYPE OF (representation);
END_ENTITY; -- 10303-41: product_property_representation_schema

ENTITY shape_representation_relationship
    SUBTYPE OF (representation_relationship);
WHERE
    WR1: 'INTEGRATED_CNC_SCHEMA.SHAPE_REPRESENTATION' IN TYPEOF(SELf\
        representation_relationship.rep_1) + TYPEOF(SELf\
        representation_relationship.rep_2);
END_ENTITY; -- 10303-41: product_property_representation_schema

ENTITY shape_representation_with_parameters
    SUBTYPE OF (shape_representation);
WHERE
    WR1: SIZEOF(QUERY (it <* SELf.items| NOT (SIZEOF([
        'INTEGRATED_CNC_SCHEMA.PLACEMENT',
        'INTEGRATED_CNC_SCHEMA.MEASURE_REPRESENTATION_ITEM',

```

```

        'INTEGRATED_CNC_SCHEMA.DESRIPTIVE_REPRESENTATION_ITEM' ] *
        TYPEOF(it) = 1))) = 0;
END_ENTITY; -- 10303-522: aic_machining_feature

ENTITY shell_based_surface_model
  SUBTYPE OF (geometric_representation_item);
  sbsm_boundary : SET [1:?] OF shell;
  WHERE
    WR1: constraints_geometry_shell_based_surface_model(SELf);
END_ENTITY; -- 10303-42: geometric_model_schema

ENTITY shell_based_wireframe_model
  SUBTYPE OF (geometric_representation_item);
  sbwm_boundary : SET [1:?] OF shell;
  WHERE
    WR1: constraints_geometry_shell_based_wireframe_model(SELf);
END_ENTITY; -- 10303-42: geometric_model_schema

ENTITY shell_based_wireframe_shape_representation
  SUBTYPE OF (shape_representation);
  WHERE
    WR1: SIZEOF(QUERY (it <* SELf.items| NOT (SIZEOF([
      'INTEGRATED_CNC_SCHEMA.SHELL_BASED_WIREFRAME_MODEL',
      'INTEGRATED_CNC_SCHEMA.MAPPED_ITEM',
      'INTEGRATED_CNC_SCHEMA.AXIS2_PLACEMENT_3D' ] * TYPEOF(it)) =
      1))) = 0;
    WR2: SIZEOF(QUERY (it <* SELf.items| (SIZEOF([
      'INTEGRATED_CNC_SCHEMA.SHELL_BASED_WIREFRAME_MODEL',
      'INTEGRATED_CNC_SCHEMA.MAPPED_ITEM' ] * TYPEOF(it)) = 1))) >=
      1;
    WR3: SIZEOF(QUERY (sbwm <* QUERY (it <* SELf.items| (
      'INTEGRATED_CNC_SCHEMA.SHELL_BASED_WIREFRAME_MODEL' IN TYPEOF
      (it)))| NOT (SIZEOF(QUERY (ws <* QUERY (sb <* sbwm\
      shell_based_wireframe_model.sbwm_boundary| (
      'INTEGRATED_CNC_SCHEMA.WIRE_SHELL' IN TYPEOF(sb)))| NOT (
      SIZEOF(QUERY (eloop <* QUERY (wsb <* ws\wire_shell.
      wire_shell_extent| ('INTEGRATED_CNC_SCHEMA.EDGE_LOOP' IN
      TYPEOF(wsb)))| NOT (SIZEOF(QUERY (el <* eloop\path.edge_list|
      NOT ('INTEGRATED_CNC_SCHEMA.EDGE_CURVE' IN TYPEOF(el.
      edge_element)))) = 0))) = 0))) = 0))) = 0;
    WR4: SIZEOF(QUERY (sbwm <* QUERY (it <* SELf.items| (
      'INTEGRATED_CNC_SCHEMA.SHELL_BASED_WIREFRAME_MODEL' IN TYPEOF
      (it)))| NOT (SIZEOF(QUERY (ws <* QUERY (sb <* sbwm\
      shell_based_wireframe_model.sbwm_boundary| (
      'INTEGRATED_CNC_SCHEMA.WIRE_SHELL' IN TYPEOF(sb)))| NOT (
      SIZEOF(QUERY (eloop <* QUERY (wsb <* ws\wire_shell.
      wire_shell_extent| ('INTEGRATED_CNC_SCHEMA.EDGE_LOOP' IN
      TYPEOF(wsb)))| NOT (SIZEOF(QUERY (pline_el <* QUERY (el <*
      eloop\path.edge_list| ('INTEGRATED_CNC_SCHEMA.POLYLINE' IN
      TYPEOF(el.edge_element\edge_curve.edge_geometry)))| NOT (
      SIZEOF(pline_el.edge_element\edge_curve.edge_geometry\
      polyline.points) > 2)))) = 0))) = 0))) = 0))) = 0;
    WR5: SIZEOF(QUERY (sbwm <* QUERY (it <* SELf.items| (
      'INTEGRATED_CNC_SCHEMA.SHELL_BASED_WIREFRAME_MODEL' IN TYPEOF

```

```

(it))| NOT (sizeof(QUERY (ws <* QUERY (sb <* sbwm\
shell_based_wireframe_model.sbwm_boundary| (
'INTEGRATED_CNC_SCHEMA.WIRE_SHELL' IN TYPEOF(sb)))| NOT (
sizeof(QUERY (eloop <* QUERY (wsb <* ws\wire_shell.
wire_shell_extent| ('INTEGRATED_CNC_SCHEMA.EDGE_LOOP' IN
TYPEOF(wsb)))| NOT (sizeof(QUERY (el <* eloop\path.edge_list|
NOT valid_wireframe_edge_curve(el.edge_element\edge_curve.
edge_geometry))) = 0))) = 0))) = 0;
WR6: sizeof(QUERY (sbwm <* QUERY (it <* SELF.items| (
'INTEGRATED_CNC_SCHEMA.SHELL_BASED_WIREFRAME_MODEL' IN TYPEOF
(it))| NOT (sizeof(QUERY (ws <* QUERY (sb <* sbwm\
shell_based_wireframe_model.sbwm_boundary| (
'INTEGRATED_CNC_SCHEMA.WIRE_SHELL' IN TYPEOF(sb)))| NOT (
sizeof(QUERY (eloop <* QUERY (wsb <* ws\wire_shell.
wire_shell_extent| ('INTEGRATED_CNC_SCHEMA.EDGE_LOOP' IN
TYPEOF(wsb)))| NOT (sizeof(QUERY (el <* eloop\path.edge_list|
NOT (('INTEGRATED_CNC_SCHEMA.VERTEX_POINT' IN TYPEOF(el.
edge_element.edge_start)) AND (
'INTEGRATED_CNC_SCHEMA.VERTEX_POINT' IN TYPEOF(el.
edge_element.edge_end)))))) = 0))) = 0))) = 0;
WR7: sizeof(QUERY (sbwm <* QUERY (it <* SELF.items| (
'INTEGRATED_CNC_SCHEMA.SHELL_BASED_WIREFRAME_MODEL' IN TYPEOF
(it))| NOT (sizeof(QUERY (ws <* QUERY (sb <* sbwm\
shell_based_wireframe_model.sbwm_boundary| (
'INTEGRATED_CNC_SCHEMA.WIRE_SHELL' IN TYPEOF(sb)))| NOT (
sizeof(QUERY (eloop <* QUERY (wsb <* ws\wire_shell.
wire_shell_extent| ('INTEGRATED_CNC_SCHEMA.EDGE_LOOP' IN
TYPEOF(wsb)))| NOT (sizeof(QUERY (el <* eloop\path.edge_list|
NOT (valid_wireframe_vertex_point(el.edge_element.edge_start
\vertex_point.vertex_geometry) AND
valid_wireframe_vertex_point(el.edge_element.edge_end\
vertex_point.vertex_geometry)))))) = 0))) = 0))) = 0;
WR8: sizeof(QUERY (sbwm <* QUERY (it <* SELF.items| (
'INTEGRATED_CNC_SCHEMA.SHELL_BASED_WIREFRAME_MODEL' IN TYPEOF
(it))| NOT (sizeof(QUERY (ws <* QUERY (sb <* sbwm\
shell_based_wireframe_model.sbwm_boundary| (
'INTEGRATED_CNC_SCHEMA.WIRE_SHELL' IN TYPEOF(sb)))| NOT (
sizeof(QUERY (vloop <* QUERY (wsb <* ws\wire_shell.
wire_shell_extent| ('INTEGRATED_CNC_SCHEMA.VERTEX_LOOP' IN
TYPEOF(wsb)))| NOT ('INTEGRATED_CNC_SCHEMA.VERTEX_POINT' IN
TYPEOF(vloop\vertex_loop.loop_vertex)))))) = 0))) = 0;
WR9: sizeof(QUERY (sbwm <* QUERY (it <* SELF.items| (
'INTEGRATED_CNC_SCHEMA.SHELL_BASED_WIREFRAME_MODEL' IN TYPEOF
(it))| NOT (sizeof(QUERY (ws <* QUERY (sb <* sbwm\
shell_based_wireframe_model.sbwm_boundary| (
'INTEGRATED_CNC_SCHEMA.WIRE_SHELL' IN TYPEOF(sb)))| NOT (
sizeof(QUERY (vloop <* QUERY (wsb <* ws\wire_shell.
wire_shell_extent| ('INTEGRATED_CNC_SCHEMA.VERTEX_LOOP' IN
TYPEOF(wsb)))| NOT valid_wireframe_vertex_point(vloop\
vertex_loop.loop_vertex\vertex_point.vertex_geometry)))))) = 0))
) = 0))) = 0;
WR10: sizeof(QUERY (sbwm <* QUERY (it <* SELF.items| (
'INTEGRATED_CNC_SCHEMA.SHELL_BASED_WIREFRAME_MODEL' IN TYPEOF
(it))| NOT (sizeof(QUERY (vs <* QUERY (sb <* sbwm\

```

```

        shell_based_wireframe_model.sbwm_boundary| (
        'INTEGRATED_CNC_SCHEMA.VERTEX_SHELL' IN TYPEOF(sb))| NOT (
        'INTEGRATED_CNC_SCHEMA.VERTEX_POINT' IN TYPEOF(vs\
        vertex_shell.vertex_shell_extent.loop_vertex)))) = 0))) = 0;
WR11: SIZEOF(QUERY (sbwm <* QUERY (it <* SELF.items| (
        'INTEGRATED_CNC_SCHEMA.SHELL_BASED_WIREFRAME_MODEL' IN TYPEOF
        (it))| NOT (SIZEOF(QUERY (vs <* QUERY (sb <* sbwm\
        shell_based_wireframe_model.sbwm_boundary| (
        'INTEGRATED_CNC_SCHEMA.VERTEX_SHELL' IN TYPEOF(sb))| NOT
        valid_wireframe_vertex_point(vs\vertex_shell.
        vertex_shell_extent.loop_vertex\vertex_point.vertex_geometry)
        )) = 0))) = 0;
WR12: SIZEOF(QUERY (mi <* QUERY (it <* SELF.items| (
        'INTEGRATED_CNC_SCHEMA.MAPPED_ITEM' IN TYPEOF(it))| NOT (
        'INTEGRATED_CNC_SCHEMA.' +
        'SHELL_BASED_WIREFRAME_SHAPE_REPRESENTATION' IN TYPEOF(mi\
        mapped_item.mapping_source.mapped_representation)))) = 0;
WR13: SELF.context_of_items\geometric_representation_context.
        coordinate_space_dimension = 3;
END_ENTITY; -- 10303-502: aic_shell_based_wireframe

ENTITY si_unit
  SUBTYPE OF (named_unit);
  prefix : OPTIONAL si_prefix;
  name   : si_unit_name;
  DERIVE
    SELF\named_unit.dimensions : dimensional_exponents :=
        dimensions_for_si_unit(name);
END_ENTITY; -- 10303-41: measure_schema

ENTITY side_milling_operation
  SUBTYPE OF (milling_type_operation);
  WHERE
  WR1: (SELF.description IN ['roughing','finishing']);

  WR2: (verify_optional_action_property      (SELF, 'axial cutting depth'))
AND
      (verify_length_measure_action_property (SELF, 'axial cutting depth'));

  WR3: (verify_optional_action_property      (SELF, 'radial cutting depth'))
AND
      (verify_length_measure_action_property (SELF, 'radial cutting depth'));

  WR4: (verify_optional_action_property      (SELF, 'allowance side')) AND
      (verify_length_measure_action_property (SELF, 'allowance side'));

  WR5: NOT (SELF.description = 'roughing') OR
      (verify_required_action_property (SELF, 'allowance side'));
END_ENTITY; -- 10303-238: integrated_cnc_schema

ENTITY simple_generic_expression
  ABSTRACT SUPERTYPE OF (ONEOF(generic_literal, generic_variable))
  SUBTYPE OF (generic_expression);
END_ENTITY; -- 13584-20: iso13584_generic_expressions_schema

```

```

ENTITY simple_numeric_expression
  ABSTRACT SUPERTYPE OF (ONEOF(literal_number, numeric_variable))
  SUBTYPE OF (numeric_expression, simple_generic_expression);
END_ENTITY; -- 13584-20: iso13584_expressions_schema

ENTITY slot
  SUBTYPE OF (feature_definition);
  WHERE
    WR1: SIZEOF(QUERY (pd <* USEDIN(SELF,
      'INTEGRATED_CNC_SCHEMA.PROPERTY_DEFINITION.DEFINITION') | NOT
      (SIZEOF(QUERY (impl_rep <* QUERY (pdr <* USEDIN(pd,
        'INTEGRATED_CNC_SCHEMA.' +
        'PROPERTY_DEFINITION_REPRESENTATION.DEFINITION') | (
        'INTEGRATED_CNC_SCHEMA.' +
        'SHAPE_REPRESENTATION_WITH_PARAMETERS' IN TYPEOF(pdr.
        used_representation)))) | NOT (SIZEOF(impl_rep.
        used_representation.items) = 1))) = 0))) = 0;
    WR2: SIZEOF(QUERY (pds <* QUERY (pd <* USEDIN(SELF,
      'INTEGRATED_CNC_SCHEMA.PROPERTY_DEFINITION.DEFINITION') | (
      'INTEGRATED_CNC_SCHEMA.PRODUCT_DEFINITION_SHAPE' IN TYPEOF(pd
      ))) | NOT (SIZEOF(QUERY (sa_occ <* USEDIN(pds,
        'INTEGRATED_CNC_SCHEMA.SHAPE_ASPECT.OF_SHAPE') | (sa_occ.
        description = 'swept shape occurrence') AND (SIZEOF(QUERY (
        sdr <* QUERY (sar <* USEDIN(sa_occ,
          'INTEGRATED_CNC_SCHEMA.SHAPE_ASPECT_RELATIONSHIP.' +
          'RELATED_SHAPE_ASPECT') | (sar.description = 'profile usage')
          AND ('INTEGRATED_CNC_SCHEMA.SHAPE_DEFINING_RELATIONSHIP' IN
          TYPEOF(sar))) | (SIZEOF([
            'INTEGRATED_CNC_SCHEMA.SQUARE_U_PROFILE',
            'INTEGRATED_CNC_SCHEMA.PARTIAL_CIRCULAR_PROFILE',
            'INTEGRATED_CNC_SCHEMA.ROUNDED_U_PROFILE',
            'INTEGRATED_CNC_SCHEMA.VEE_PROFILE',
            'INTEGRATED_CNC_SCHEMA.TEE_PROFILE',
            'INTEGRATED_CNC_SCHEMA.OPEN_PATH_PROFILE' ] * TYPEOF(sdr.
            relating_shape_aspect)) = 1))) = 1))) = 1))) = 0;
    WR3: SIZEOF(QUERY (pds <* QUERY (pd <* USEDIN(SELF,
      'INTEGRATED_CNC_SCHEMA.PROPERTY_DEFINITION.DEFINITION') | (
      'INTEGRATED_CNC_SCHEMA.PRODUCT_DEFINITION_SHAPE' IN TYPEOF(pd
      ))) | NOT (SIZEOF(QUERY (sa_occ <* USEDIN(pds,
        'INTEGRATED_CNC_SCHEMA.SHAPE_ASPECT.OF_SHAPE') | (sa_occ.
        description = 'course of travel occurrence') AND (SIZEOF(
        QUERY (sdr <* QUERY (sar <* USEDIN(sa_occ,
          'INTEGRATED_CNC_SCHEMA.SHAPE_ASPECT_RELATIONSHIP.' +
          'RELATED_SHAPE_ASPECT') | (sar.description =
          'path feature component usage') AND ((sar.name =
          'course of travel') AND (
          'INTEGRATED_CNC_SCHEMA.SHAPE_DEFINING_RELATIONSHIP' IN TYPEOF
          (sar)))) | ('INTEGRATED_CNC_SCHEMA.PATH_FEATURE_COMPONENT' IN
          TYPEOF(sdr.relatng_shape_aspect)))) = 1))) = 1))) = 0;
    WR4: SIZEOF(QUERY (pds <* QUERY (pd <* USEDIN(SELF,
      'INTEGRATED_CNC_SCHEMA.PROPERTY_DEFINITION.DEFINITION') | (
      'INTEGRATED_CNC_SCHEMA.PRODUCT_DEFINITION_SHAPE' IN TYPEOF(pd
      ))) | NOT ((SIZEOF(QUERY (sa_occ <* USEDIN(pds,

```

```
'INTEGRATED_CNC_SCHEMA.SHAPE_ASPECT.OF_SHAPE')| (sa_occ.
description = 'end condition occurrence') AND (SIZEOF(QUERY (
fcr <* QUERY (sar <* USEDIN(sa_occ, 'INTEGRATED_CNC_SCHEMA.'
+ 'SHAPE_ASPECT_RELATIONSHIP.RELATED_SHAPE_ASPECT')| ((sar.
description = 'slot end usage') AND (sar.name IN [
'course of travel start', 'course of travel end' ])) AND (
'INTEGRATED_CNC_SCHEMA.FEATURE_COMPONENT_RELATIONSHIP' IN
TYPEOF(sar)))| (('INTEGRATED_CNC_SCHEMA.SLOT_END' IN TYPEOF(
fcr.relying_shape_aspect)) AND (fcr.relying_shape_aspect.
description IN [ 'open', 'radiused', 'flat', 'woodruff' ]))
AND ('INTEGRATED_CNC_SCHEMA.SLOT' IN TYPEOF(fcr.
related_shape_aspect.of_shape.definition)))) = 1))) = 2) OR (
SIZEOF(QUERY (sa_occ <* USEDIN(pds,
'INTEGRATED_CNC_SCHEMA.SHAPE_ASPECT.OF_SHAPE')| (sa_occ.
description = 'end condition occurrence') AND (SIZEOF(QUERY (
fcr <* QUERY (sar <* USEDIN(sa_occ, 'INTEGRATED_CNC_SCHEMA.'
+ 'SHAPE_ASPECT_RELATIONSHIP.RELATED_SHAPE_ASPECT')| ((sar.
description = 'slot end usage') AND (sar.name IN [
'course of travel start', 'course of travel end' ])) AND (
'INTEGRATED_CNC_SCHEMA.FEATURE_COMPONENT_RELATIONSHIP' IN
TYPEOF(sar)))| (('INTEGRATED_CNC_SCHEMA.SLOT_END' IN TYPEOF(
fcr.relying_shape_aspect)) AND (fcr.relying_shape_aspect.
description IN [ 'loop' ])) AND ('INTEGRATED_CNC_SCHEMA.SLOT'
IN TYPEOF(fcr.related_shape_aspect.of_shape.definition)))) =
1)))) = 1))) = 0;
```

```
WR5: NOT (SIZEOF(QUERY (pds <* QUERY (pd <* USEDIN(SELF,
'INTEGRATED_CNC_SCHEMA.PROPERTY_DEFINITION.DEFINITION')| (
'INTEGRATED_CNC_SCHEMA.PRODUCT_DEFINITION_SHAPE' IN TYPEOF(pd
)))| NOT (SIZEOF(QUERY (sa_occ <* USEDIN(pds,
'INTEGRATED_CNC_SCHEMA.SHAPE_ASPECT.OF_SHAPE')| (sa_occ.
description = 'end condition occurrence') AND (SIZEOF(QUERY (
fcr <* QUERY (sar <* USEDIN(sa_occ,
'INTEGRATED_CNC_SCHEMA.SHAPE_ASPECT_RELATIONSHIP.' +
'RELATED_SHAPE_ASPECT')| ((sar.description = 'slot end usage'
) AND (sar.name IN [ 'course of travel start',
'course of travel end' ])) AND (
'INTEGRATED_CNC_SCHEMA.FEATURE_COMPONENT_RELATIONSHIP' IN
TYPEOF(sar)))| (('INTEGRATED_CNC_SCHEMA.SLOT_END' IN TYPEOF(
fcr.relying_shape_aspect)) AND (fcr.relying_shape_aspect.
description IN [ 'loop' ])) AND ('INTEGRATED_CNC_SCHEMA.SLOT'
IN TYPEOF(fcr.related_shape_aspect.of_shape.definition)))) =
1))) = 1))) = 0) OR (SIZEOF(QUERY (pds <* QUERY (pd <*
USEDIN(SELF,
'INTEGRATED_CNC_SCHEMA.PROPERTY_DEFINITION.DEFINITION')| (
'INTEGRATED_CNC_SCHEMA.PRODUCT_DEFINITION_SHAPE' IN TYPEOF(pd
)))| NOT (SIZEOF(QUERY (sa_occ <* USEDIN(pds,
'INTEGRATED_CNC_SCHEMA.SHAPE_ASPECT.OF_SHAPE')| (sa_occ.
description = 'course of travel occurrence') AND (SIZEOF(
QUERY (sdr <* QUERY (sar <* USEDIN(sa_occ,
'INTEGRATED_CNC_SCHEMA.SHAPE_ASPECT_RELATIONSHIP.' +
'RELATED_SHAPE_ASPECT')| (sar.description =
'path feature component usage') AND ((sar.name =
'course of travel') AND (
'INTEGRATED_CNC_SCHEMA.SHAPE_DEFINING_RELATIONSHIP' IN TYPEOF
```

```

(sar))))| ('INTEGRATED_CNC_SCHEMA.PATH_FEATURE_COMPONENT' IN
TYPEOF(sdr.relatng_shape_aspect)) AND (sdr.
relatng_shape_aspect.description IN [ 'complex',
'complete circular' ]))) = 1))) = 1))) = 0);
WR6: SIZEOF(QUERY (pdr <* get_property_definition_representations(SELF)
| ('INTEGRATED_CNC_SCHEMA.PLANAR_SHAPE_REPRESENTATION' IN
TYPEOF(pdr.used_representation)) AND (pdr.used_representation
.name = 'maximum feature limit')))) >= 0;
END_ENTITY; -- 10303-522: aic_machining_feature

```

```

ENTITY slot_end
SUBTYPE OF (shape_aspect);
WHERE
WR1: 'INTEGRATED_CNC_SCHEMA.FEATURE_COMPONENT_DEFINITION' IN TYPEOF(
SELF.of_shape.definition);
WR2: SELF.description IN [ 'open', 'radiused', 'flat', 'woodruff',
'loop' ];
WR3: NOT (SELF.description IN [ 'open', 'radiused', 'loop' ]) OR (
SIZEOF(QUERY (pd <* USEDIN(SELF,
'INTEGRATED_CNC_SCHEMA.PROPERTY_DEFINITION.DEFINITION')| NOT
(SIZEOF(QUERY (pdr <* USEDIN(pd, 'INTEGRATED_CNC_SCHEMA.' +
'PROPERTY_DEFINITION_REPRESENTATION.DEFINITION')| (
'INTEGRATED_CNC_SCHEMA.SHAPE_REPRESENTATION_WITH_PARAMETERS'
IN TYPEOF(pdr.used_representation)))) = 0))) = 0);
WR4: NOT (SELF.description IN [ 'flat', 'woodruff' ]) OR (SIZEOF(QUERY
(pd <* USEDIN(SELF,
'INTEGRATED_CNC_SCHEMA.PROPERTY_DEFINITION.DEFINITION')| NOT
(SIZEOF(QUERY (pdr <* USEDIN(pd, 'INTEGRATED_CNC_SCHEMA.' +
'PROPERTY_DEFINITION_REPRESENTATION.DEFINITION')| (
'INTEGRATED_CNC_SCHEMA.SHAPE_REPRESENTATION_WITH_PARAMETERS'
IN TYPEOF(pdr.used_representation)))) = 1))) = 0);
WR5: NOT (SELF.description IN [ 'flat' ]) OR (SIZEOF(QUERY (pd <*
USEDIN(SELF,
'INTEGRATED_CNC_SCHEMA.PROPERTY_DEFINITION.DEFINITION')| NOT
(SIZEOF(QUERY (impl_rep <* QUERY (pdr <* USEDIN(pd,
'INTEGRATED_CNC_SCHEMA.' +
'PROPERTY_DEFINITION_REPRESENTATION.DEFINITION')| (
'INTEGRATED_CNC_SCHEMA.SHAPE_REPRESENTATION_WITH_PARAMETERS'
IN TYPEOF(pdr.used_representation))| NOT (SIZEOF(impl_rep.
used_representation.items) = 2))) = 0))) = 0);
WR6: NOT (SELF.description = 'flat') OR (SIZEOF(QUERY (pd <* USEDIN(
SELF, 'INTEGRATED_CNC_SCHEMA.PROPERTY_DEFINITION.DEFINITION')
| NOT (SIZEOF(QUERY (impl_rep <* QUERY (pdr <* USEDIN(pd,
'INTEGRATED_CNC_SCHEMA.' +
'PROPERTY_DEFINITION_REPRESENTATION.DEFINITION')| (
'INTEGRATED_CNC_SCHEMA.SHAPE_REPRESENTATION_WITH_PARAMETERS'
IN TYPEOF(pdr.used_representation))| NOT (SIZEOF(QUERY (it
<* impl_rep.used_representation.items| (SIZEOF([
'INTEGRATED_CNC_SCHEMA.MEASURE_REPRESENTATION_ITEM',
'INTEGRATED_CNC_SCHEMA.LENGTH_MEASURE_WITH_UNIT' ] * TYPEOF(
it)) = 2) AND (it.name = 'first radius')) = 1))) = 0))) = 0)
;
WR7: NOT (SELF.description = 'flat') OR (SIZEOF(QUERY (pd <* USEDIN(
SELF, 'INTEGRATED_CNC_SCHEMA.PROPERTY_DEFINITION.DEFINITION')

```

```

| NOT (SIZEOF(QUERY (impl_rep <* QUERY (pdr <* USEDIN(pd,
'INTEGRATED_CNC_SCHEMA.' +
'PROPERTY_DEFINITION_REPRESENTATION.DEFINITION')| (
'INTEGRATED_CNC_SCHEMA.SHAPE_REPRESENTATION_WITH_PARAMETERS'
IN TYPEOF(pdr.used_representation)))| NOT (SIZEOF(QUERY (it
<* impl_rep.used_representation.items| (SIZEOF([
'INTEGRATED_CNC_SCHEMA.MEASURE_REPRESENTATION_ITEM',
'INTEGRATED_CNC_SCHEMA.LENGTH_MEASURE_WITH_UNIT' ] * TYPEOF(
it)) = 2) AND (it.name = 'second radius'))) = 1))) = 0))) = 0)
);
WR8: NOT (SELF.description = 'woodruff') OR (SIZEOF(QUERY (pd <* USEDIN
(SELF, 'INTEGRATED_CNC_SCHEMA.PROPERTY_DEFINITION.DEFINITION'
)| NOT (SIZEOF(QUERY (impl_rep <* QUERY (pdr <* USEDIN(pd,
'INTEGRATED_CNC_SCHEMA.' +
'PROPERTY_DEFINITION_REPRESENTATION.DEFINITION')| (
'INTEGRATED_CNC_SCHEMA.SHAPE_REPRESENTATION_WITH_PARAMETERS'
IN TYPEOF(pdr.used_representation)))| NOT (SIZEOF(QUERY (it
<* impl_rep.used_representation.items| (
'INTEGRATED_CNC_SCHEMA.LENGTH_MEASURE_WITH_UNIT' IN TYPEOF(it
)) AND (it.name = 'radius'))) = 1))) = 0))) = 0);
WR9: NOT (SELF.description IN [ 'woodruff' ]) OR (SIZEOF(QUERY (pd <*
USEDIN(SELF,
'INTEGRATED_CNC_SCHEMA.PROPERTY_DEFINITION.DEFINITION')| NOT
(SIZEOF(QUERY (impl_rep <* QUERY (pdr <* USEDIN(pd,
'INTEGRATED_CNC_SCHEMA.' +
'PROPERTY_DEFINITION_REPRESENTATION.DEFINITION')| (
'INTEGRATED_CNC_SCHEMA.SHAPE_REPRESENTATION_WITH_PARAMETERS'
IN TYPEOF(pdr.used_representation)))| NOT (SIZEOF(impl_rep.
used_representation.items) = 1))) = 0))) = 0);
WR10: SIZEOF(QUERY (fcr <* QUERY (sar <* USEDIN(SELF,
'INTEGRATED_CNC_SCHEMA.SHAPE_ASPECT_RELATIONSHIP.' +
'RELATING_SHAPE_ASPECT')| ((sar.description =
'slot end usage') AND (sar.name IN [ 'course of travel start'
, 'course of travel end' ])) AND (
'INTEGRATED_CNC_SCHEMA.FEATURE_COMPONENT_RELATIONSHIP' IN
TYPEOF(sar)))| ((fcr.related_shape_aspect.description =
'end condition occurrence') AND ('INTEGRATED_CNC_SCHEMA.SLOT'
IN TYPEOF(fcr.related_shape_aspect.of_shape.definition)))
AND ('INTEGRATED_CNC_SCHEMA.SLOT_END' IN TYPEOF(fcr.
relating_shape_aspect)))) >= 1;
END_ENTITY; -- 10303-522: aic_machining_feature

ENTITY solid_angle_measure_with_unit
SUBTYPE OF (measure_with_unit);
WHERE
WR1: 'INTEGRATED_CNC_SCHEMA.SOLID_ANGLE_UNIT' IN TYPEOF(SELF\
measure_with_unit.unit_component);
END_ENTITY; -- 10303-41: measure_schema

ENTITY solid_angle_unit
SUBTYPE OF (named_unit);
WHERE
WR1: ((((((SELF\named_unit.dimensions.length_exponent = 0.0) AND (SELF\
named_unit.dimensions.mass_exponent = 0.0)) AND (SELF\

```



```

named_unit.dimensions.time_exponent = 0.0)) AND (SELF\
named_unit.dimensions.electric_current_exponent = 0.0)) AND (
SELF\named_unit.dimensions.thermodynamic_temperature_exponent
= 0.0)) AND (SELF\named_unit.dimensions.
amount_of_substance_exponent = 0.0)) AND (SELF\named_unit.
dimensions.luminous_intensity_exponent = 0.0);
END_ENTITY; -- 10303-41: measure_schema

ENTITY solid_model
  SUPERTYPE OF (manifold_solid_brep)
  SUBTYPE OF (geometric_representation_item);
END_ENTITY; -- 10303-42: geometric_model_schema

ENTITY spherical_cap
  SUBTYPE OF (feature_definition);
  WHERE
    WR1: SIZEOF(QUERY (pd <* USEDIN(SELF,
      'INTEGRATED_CNC_SCHEMA.PROPERTY_DEFINITION.DEFINITION') | NOT
      (SIZEOF(QUERY (impl_rep <* QUERY (pdr <* USEDIN(pd,
        'INTEGRATED_CNC_SCHEMA.' +
        'PROPERTY_DEFINITION_REPRESENTATION.DEFINITION') | (
        'INTEGRATED_CNC_SCHEMA.' +
        'SHAPE_REPRESENTATION_WITH_PARAMETERS' IN TYPEOF(pdr.
        used_representation))) | NOT (SIZEOF(impl_rep.
        used_representation.items) = 3))) = 0))) = 0;
    WR2: SIZEOF(QUERY (pd <* USEDIN(SELF,
      'INTEGRATED_CNC_SCHEMA.PROPERTY_DEFINITION.DEFINITION') | NOT
      (SIZEOF(QUERY (impl_rep <* QUERY (pdr <* USEDIN(pd,
        'INTEGRATED_CNC_SCHEMA.' +
        'PROPERTY_DEFINITION_REPRESENTATION.DEFINITION') | (
        'INTEGRATED_CNC_SCHEMA.' +
        'SHAPE_REPRESENTATION_WITH_PARAMETERS' IN TYPEOF(pdr.
        used_representation))) | NOT (SIZEOF(QUERY (it <* impl_rep.
        used_representation.items | (SIZEOF([
        'INTEGRATED_CNC_SCHEMA.MEASURE_REPRESENTATION_ITEM',
        'INTEGRATED_CNC_SCHEMA.LENGTH_MEASURE_WITH_UNIT' ] * TYPEOF(
        it)) = 2) AND (it.name = 'radius')) = 1))) = 0))) = 0;
    WR3: SIZEOF(QUERY (pd <* USEDIN(SELF,
      'INTEGRATED_CNC_SCHEMA.PROPERTY_DEFINITION.DEFINITION') | NOT
      (SIZEOF(QUERY (impl_rep <* QUERY (pdr <* USEDIN(pd,
        'INTEGRATED_CNC_SCHEMA.' +
        'PROPERTY_DEFINITION_REPRESENTATION.DEFINITION') | (
        'INTEGRATED_CNC_SCHEMA.' +
        'SHAPE_REPRESENTATION_WITH_PARAMETERS' IN TYPEOF(pdr.
        used_representation))) | NOT (SIZEOF(QUERY (it <* impl_rep.
        used_representation.items | (SIZEOF([
        'INTEGRATED_CNC_SCHEMA.MEASURE_REPRESENTATION_ITEM',
        'INTEGRATED_CNC_SCHEMA.PLANE_ANGLE_MEASURE_WITH_UNIT' ] *
        TYPEOF(it)) = 2) AND (it.name = 'internal angle')) = 1))) =
        0))) = 0;
  END_ENTITY; -- 10303-522: aic_machining_feature

ENTITY spherical_surface
  SUBTYPE OF (elementary_surface);

```

```

    radius : positive_length_measure;
END_ENTITY; -- 10303-42: geometry_schema

ENTITY square_u_profile
  SUBTYPE OF (shape_aspect);
  WHERE
    WR1: 'INTEGRATED_CNC_SCHEMA.FEATURE_COMPONENT_DEFINITION' IN TYPEOF(
      SELF.of_shape.definition);
    WR2: SIZEOF(QUERY (pd <* USEDIN(SELF,
      'INTEGRATED_CNC_SCHEMA.PROPERTY_DEFINITION.DEFINITION') | NOT
      (SIZEOF(QUERY (pdr <* USEDIN(pd, 'INTEGRATED_CNC_SCHEMA.' +
      'PROPERTY_DEFINITION_REPRESENTATION.DEFINITION') | (
      'INTEGRATED_CNC_SCHEMA.' +
      'SHAPE_REPRESENTATION_WITH_PARAMETERS' IN TYPEOF(pdr.
      used_representation)))) = 1))) = 0;
    WR3: SIZEOF(QUERY (pd <* USEDIN(SELF,
      'INTEGRATED_CNC_SCHEMA.PROPERTY_DEFINITION.DEFINITION') | NOT
      (SIZEOF(QUERY (impl_rep <* QUERY (pdr <* USEDIN(pd,
      'INTEGRATED_CNC_SCHEMA.' +
      'PROPERTY_DEFINITION_REPRESENTATION.DEFINITION') | (
      'INTEGRATED_CNC_SCHEMA.' +
      'SHAPE_REPRESENTATION_WITH_PARAMETERS' IN TYPEOF(pdr.
      used_representation))) | NOT (SIZEOF(impl_rep.
      used_representation.items) >= 4) AND (SIZEOF(impl_rep.
      used_representation.items) <= 7))) = 0))) = 0;
    WR4: SIZEOF(QUERY (pd <* USEDIN(SELF,
      'INTEGRATED_CNC_SCHEMA.PROPERTY_DEFINITION.DEFINITION') | (
      SIZEOF(QUERY (pdr <* USEDIN(pd, 'INTEGRATED_CNC_SCHEMA.' +
      'PROPERTY_DEFINITION_REPRESENTATION.DEFINITION') | (
      'INTEGRATED_CNC_SCHEMA.' +
      'SHAPE_REPRESENTATION_WITH_PARAMETERS' IN TYPEOF(pdr.
      used_representation)) AND (SIZEOF(QUERY (srwp_i <* pdr.
      used_representation.items | ((((((srwp_i.name = 'orientation'
      ) OR (srwp_i.name = 'width')) OR (srwp_i.name = 'first angle'
      )) OR (srwp_i.name = 'second angle')) OR (srwp_i.name =
      'first radius')) OR (srwp_i.name = 'second radius')) OR (
      srwp_i.name = 'profile limit')) OR (srwp_i.name = 'depth'))
      = SIZEOF(pdr.used_representation.items)))) = 1))) = 1;
    WR5: SIZEOF(QUERY (pd <* USEDIN(SELF,
      'INTEGRATED_CNC_SCHEMA.PROPERTY_DEFINITION.DEFINITION') | NOT
      (SIZEOF(QUERY (impl_rep <* QUERY (pdr <* USEDIN(pd,
      'INTEGRATED_CNC_SCHEMA.' +
      'PROPERTY_DEFINITION_REPRESENTATION.DEFINITION') | (
      'INTEGRATED_CNC_SCHEMA.' +
      'SHAPE_REPRESENTATION_WITH_PARAMETERS' IN TYPEOF(pdr.
      used_representation))) | NOT (SIZEOF(QUERY (it <* impl_rep.
      used_representation.items | ('INTEGRATED_CNC_SCHEMA.PLACEMENT'
      IN TYPEOF(it)) AND (it.name = 'orientation')) = 1))) = 0)))
      = 0;
    WR6: SIZEOF(QUERY (pd <* USEDIN(SELF,
      'INTEGRATED_CNC_SCHEMA.PROPERTY_DEFINITION.DEFINITION') | NOT
      (SIZEOF(QUERY (impl_rep <* QUERY (pdr <* USEDIN(pd,
      'INTEGRATED_CNC_SCHEMA.' +
      'PROPERTY_DEFINITION_REPRESENTATION.DEFINITION') | (

```

```

'INTEGRATED_CNC_SCHEMA.' +
'SHAPE_REPRESENTATION_WITH_PARAMETERS' IN TYPEOF(pdr.
used_representation)))| NOT (SIZEOF(QUERY (it <* impl_rep.
used_representation.items| (SIZEOF([
'INTEGRATED_CNC_SCHEMA.MEASURE_REPRESENTATION_ITEM',
'INTEGRATED_CNC_SCHEMA.LENGTH_MEASURE_WITH_UNIT' ] * TYPEOF(
it)) = 2) AND (it.name = 'width'))) = 1))) = 0))) = 0;
WR7: SIZEOF(QUERY (pd <* USEDIN(SELF,
'INTEGRATED_CNC_SCHEMA.PROPERTY_DEFINITION.DEFINITION')| NOT
(SIZEOF(QUERY (impl_rep <* QUERY (pdr <* USEDIN(pd,
'INTEGRATED_CNC_SCHEMA.' +
'PROPERTY_DEFINITION_REPRESENTATION.DEFINITION')| (
'INTEGRATED_CNC_SCHEMA.' +
'SHAPE_REPRESENTATION_WITH_PARAMETERS' IN TYPEOF(pdr.
used_representation)))| NOT (SIZEOF(QUERY (it <* impl_rep.
used_representation.items| (SIZEOF([
'INTEGRATED_CNC_SCHEMA.MEASURE_REPRESENTATION_ITEM',
'INTEGRATED_CNC_SCHEMA.LENGTH_MEASURE_WITH_UNIT' ] * TYPEOF(
it)) = 2) AND (it.name = 'first radius'))) <= 1))) = 0))) = 0
;
WR8: SIZEOF(QUERY (pd <* USEDIN(SELF,
'INTEGRATED_CNC_SCHEMA.PROPERTY_DEFINITION.DEFINITION')| NOT
(SIZEOF(QUERY (impl_rep <* QUERY (pdr <* USEDIN(pd,
'INTEGRATED_CNC_SCHEMA.' +
'PROPERTY_DEFINITION_REPRESENTATION.DEFINITION')| (
'INTEGRATED_CNC_SCHEMA.' +
'SHAPE_REPRESENTATION_WITH_PARAMETERS' IN TYPEOF(pdr.
used_representation)))| NOT (SIZEOF(QUERY (it <* impl_rep.
used_representation.items| (SIZEOF([
'INTEGRATED_CNC_SCHEMA.MEASURE_REPRESENTATION_ITEM',
'INTEGRATED_CNC_SCHEMA.LENGTH_MEASURE_WITH_UNIT' ] * TYPEOF(
it)) = 2) AND (it.name = 'second radius'))) <= 1))) = 0))) =
0;
WR9: SIZEOF(QUERY (pd <* USEDIN(SELF,
'INTEGRATED_CNC_SCHEMA.PROPERTY_DEFINITION.DEFINITION')| NOT
(SIZEOF(QUERY (impl_rep <* QUERY (pdr <* USEDIN(pd,
'INTEGRATED_CNC_SCHEMA.' +
'PROPERTY_DEFINITION_REPRESENTATION.DEFINITION')| (
'INTEGRATED_CNC_SCHEMA.' +
'SHAPE_REPRESENTATION_WITH_PARAMETERS' IN TYPEOF(pdr.
used_representation)))| NOT (SIZEOF(QUERY (it <* impl_rep.
used_representation.items| (SIZEOF([
'INTEGRATED_CNC_SCHEMA.MEASURE_REPRESENTATION_ITEM',
'INTEGRATED_CNC_SCHEMA.PLANE_ANGLE_MEASURE_WITH_UNIT' ] *
TYPEOF(it)) = 2) AND (it.name = 'first angle'))) = 1))) = 0))
) = 0;
WR10: SIZEOF(QUERY (pd <* USEDIN(SELF,
'INTEGRATED_CNC_SCHEMA.PROPERTY_DEFINITION.DEFINITION')| NOT
(SIZEOF(QUERY (impl_rep <* QUERY (pdr <* USEDIN(pd,
'INTEGRATED_CNC_SCHEMA.' +
'PROPERTY_DEFINITION_REPRESENTATION.DEFINITION')| (
'INTEGRATED_CNC_SCHEMA.' +
'SHAPE_REPRESENTATION_WITH_PARAMETERS' IN TYPEOF(pdr.
used_representation)))| NOT (SIZEOF(QUERY (it <* impl_rep.

```

```

used_representation.items| (SIZEOF([
'INTEGRATED_CNC_SCHEMA.MEASURE_REPRESENTATION_ITEM',
'INTEGRATED_CNC_SCHEMA.PLANE_ANGLE_MEASURE_WITH_UNIT' ] *
TYPEOF(it)) = 2) AND (it.name = 'second angle')) = 1))) = 0)
)) = 0;
WR11: SIZEOF(QUERY (pd <* USEDIN(SELF,
'INTEGRATED_CNC_SCHEMA.PROPERTY_DEFINITION.' + 'DEFINITION')|
NOT (SIZEOF(QUERY (pdr <* USEDIN(pd,
'INTEGRATED_CNC_SCHEMA.' +
'PROPERTY_DEFINITION_REPRESENTATION.DEFINITION')| (
'INTEGRATED_CNC_SCHEMA.PLANAR_SHAPE_REPRESENTATION' IN TYPEOF
(pdr.used_representation)) AND (pdr.used_representation.name
= 'profile limit')) <= 1))) = 0;
WR12: SIZEOF(QUERY (pd <* USEDIN(SELF,
'INTEGRATED_CNC_SCHEMA.PROPERTY_DEFINITION.DEFINITION')| NOT
(SIZEOF(QUERY (impl_rep <* QUERY (pdr <* USEDIN(pd,
'INTEGRATED_CNC_SCHEMA.' +
'PROPERTY_DEFINITION_REPRESENTATION.DEFINITION')| (
'INTEGRATED_CNC_SCHEMA.' +
'SHAPE_REPRESENTATION_WITH_PARAMETERS' IN TYPEOF(pdr.
used_representation)))| NOT (SIZEOF(QUERY (it <* impl_rep.
used_representation.items| (SIZEOF([
'INTEGRATED_CNC_SCHEMA.MEASURE_REPRESENTATION_ITEM',
'INTEGRATED_CNC_SCHEMA.LENGTH_MEASURE_WITH_UNIT' ] * TYPEOF(
it)) = 2) AND (it.name = 'depth')) <= 1))) = 0))) = 0;
END_ENTITY; -- 10303-522: aic_machining_feature

```

```

ENTITY standard_uncertainty
  SUPERTYPE OF (expanded_uncertainty)
  SUBTYPE OF (uncertainty_qualifier);
  uncertainty_value : REAL;
END_ENTITY; -- 10303-45: qualified_measure_schema

```

```

ENTITY step
  SUBTYPE OF (feature_definition);
  WHERE
    WR1: SIZEOF(QUERY (pd <* USEDIN(SELF,
      'INTEGRATED_CNC_SCHEMA.PROPERTY_DEFINITION.DEFINITION')| NOT
      (SIZEOF(QUERY (impl_rep <* QUERY (pdr <* USEDIN(pd,
        'INTEGRATED_CNC_SCHEMA.' +
        'PROPERTY_DEFINITION_REPRESENTATION.DEFINITION')| (
        'INTEGRATED_CNC_SCHEMA.' +
        'SHAPE_REPRESENTATION_WITH_PARAMETERS' IN TYPEOF(pdr.
        used_representation)))| NOT (SIZEOF(impl_rep.
        used_representation.items) = 1))) = 0))) = 0;
    WR2: SIZEOF(QUERY (pds <* QUERY (pd <* USEDIN(SELF,
      'INTEGRATED_CNC_SCHEMA.PROPERTY_DEFINITION.DEFINITION')| (
      'INTEGRATED_CNC_SCHEMA.PRODUCT_DEFINITION_SHAPE' IN TYPEOF(pd
      )))| NOT (SIZEOF(QUERY (sa_occ <* USEDIN(pds,
        'INTEGRATED_CNC_SCHEMA.SHAPE_ASPECT.OF_SHAPE')| (sa_occ.
        description = 'course of travel occurrence') AND (SIZEOF(
        QUERY (sdr <* QUERY (sar <* USEDIN(sa_occ,
          'INTEGRATED_CNC_SCHEMA.SHAPE_ASPECT_RELATIONSHIP.' +
          'RELATED_SHAPE_ASPECT')| (sar.description =

```

```

'path feature component usage') AND (
'INTEGRATED_CNC_SCHEMA.SHAPE_DEFINING_RELATIONSHIP' IN TYPEOF
(sar)))| ('INTEGRATED_CNC_SCHEMA.PATH_FEATURE_COMPONENT' IN
TYPEOF(sdr.relying_shape_aspect)) AND (sdr.
relying_shape_aspect.description = 'linear')) = 1))) = 1)))
= 0;
WR3: SIZEOF(QUERY (pds <* QUERY (pd <* USEDIN(SELF,
'INTEGRATED_CNC_SCHEMA.PROPERTY_DEFINITION.DEFINITION')| (
'INTEGRATED_CNC_SCHEMA.PRODUCT_DEFINITION_SHAPE' IN TYPEOF(pd
)))| NOT (SIZEOF(QUERY (sa_occ <* USEDIN(pds,
'INTEGRATED_CNC_SCHEMA.SHAPE_ASPECT.OF_SHAPE')| (sa_occ.
description = 'removal boundary occurrence') AND (SIZEOF(
QUERY (sdr <* QUERY (sar <* USEDIN(sa_occ,
'INTEGRATED_CNC_SCHEMA.SHAPE_ASPECT_RELATIONSHIP.' +
'RELATED_SHAPE_ASPECT')| (sar.description = 'profile usage')
AND ('INTEGRATED_CNC_SCHEMA.SHAPE_DEFINING_RELATIONSHIP' IN
TYPEOF(sar)))| ('INTEGRATED_CNC_SCHEMA.VEE_PROFILE' IN TYPEOF
(sdr.relying_shape_aspect)))) = 1))) = 1))) = 0;
WR4: SIZEOF(QUERY (pdr <* get_property_definition_representations(SELF)
| ('INTEGRATED_CNC_SCHEMA.PLANAR_SHAPE_REPRESENTATION' IN
TYPEOF(pdr.used_representation)) AND (pdr.used_representation
.name = 'maximum feature limit')) >= 0;
WR5: SIZEOF(QUERY (pds <* USEDIN(SELF,
'INTEGRATED_CNC_SCHEMA.PROPERTY_DEFINITION.DEFINITION')| (
'INTEGRATED_CNC_SCHEMA.PRODUCT_DEFINITION_SHAPE' IN TYPEOF(
pds)) AND (SIZEOF(QUERY (csa <* USEDIN(pds,
'INTEGRATED_CNC_SCHEMA.SHAPE_ASPECT.OF_SHAPE')| ((
'INTEGRATED_CNC_SCHEMA.COMPOSITE_SHAPE_ASPECT' IN TYPEOF(csa)
) AND (csa.name = 'uncut volume')) AND (SIZEOF(QUERY (sar <*
csa.component_relationships| (
'INTEGRATED_CNC_SCHEMA.FEATURE_COMPONENT_RELATIONSHIP' IN
TYPEOF(sar)) AND (SIZEOF([ 'INTEGRATED_CNC_SCHEMA.BOSS',
'INTEGRATED_CNC_SCHEMA.PROTRUSION' ] * TYPEOF(sar.
related_shape_aspect)) = 1))) = 1))) <= 1))) = 1;
END_ENTITY; -- 10303-522: aic_machining_feature

ENTITY straightness_tolerance
SUBTYPE OF (geometric_tolerance);
WHERE
WR1: NOT ('INTEGRATED_CNC_SCHEMA.' +
'GEOMETRIC_TOLERANCE_WITH_DATUM_REFERENCE' IN TYPEOF(SELF));
END_ENTITY; -- 10303-519: aic_geometric_tolerances

ENTITY surface
SUPERTYPE OF (ONEOF(elementary_surface, swept_surface, bounded_surface,
offset_surface, surface_replica))
SUBTYPE OF (geometric_representation_item);
END_ENTITY; -- 10303-42: geometry_schema

ENTITY surface_curve
SUPERTYPE OF (ONEOF(intersection_curve, seam_curve) ANDOR
bounded_surface_curve)
SUBTYPE OF (curve);
curve_3d : curve;

```

ISO 10303-238:2007(E)

```

    associated_geometry : LIST [1:2] OF pcurve_or_surface;
    master_representation : preferred_surface_curve_representation;
    DERIVE
    basis_surface : SET [1:2] OF surface := get_basis_surface(SELF);
    WHERE
    WR1: curve_3d.dim = 3;
    WR2: ('INTEGRATED_CNC_SCHEMA.PCURVE' IN TYPEOF(associated_geometry[1]))
        OR (master_representation <> pcurve_s1);
    WR3: ('INTEGRATED_CNC_SCHEMA.PCURVE' IN TYPEOF(associated_geometry[2]))
        OR (master_representation <> pcurve_s2);
    WR4: NOT ('INTEGRATED_CNC_SCHEMA.PCURVE' IN TYPEOF(curve_3d));
    END_ENTITY; -- 10303-42: geometry_schema

```

```

ENTITY surface_of_linear_extrusion
    SUBTYPE OF (swept_surface);
    extrusion_axis : vector;
    END_ENTITY; -- 10303-42: geometry_schema

```

```

ENTITY surface_of_revolution
    SUBTYPE OF (swept_surface);
    axis_position : axis1_placement;
    DERIVE
    axis_line : line := representation_item('') ||
        geometric_representation_item() || curve() || line(
            axis_position.location, representation_item('') ||
            geometric_representation_item() || vector(axis_position.
                z, 1.0));
    END_ENTITY; -- 10303-42: geometry_schema

```

```

ENTITY surface_patch
    SUBTYPE OF (founded_item);
    parent_surface : bounded_surface;
    u_transition : transition_code;
    v_transition : transition_code;
    u_sense : BOOLEAN;
    v_sense : BOOLEAN;
    INVERSE
    using_surfaces : BAG [1:?] OF rectangular_composite_surface FOR
        segments;
    WHERE
    WR1: NOT ('INTEGRATED_CNC_SCHEMA.CURVE_BOUNDED_SURFACE' IN TYPEOF(
        parent_surface));
    END_ENTITY; -- 10303-42: geometry_schema

```

```

ENTITY surface_profile_tolerance
    SUBTYPE OF (geometric_tolerance);
    WHERE
    WR1: NOT ('INTEGRATED_CNC_SCHEMA.' +
        'GEOMETRIC_TOLERANCE_WITH_DATUM_REFERENCE' IN TYPEOF(SELF))
        OR (SIZEOF(SELF\geometric_tolerance_with_datum_reference.
            datum_system) <= 3);
    END_ENTITY; -- 10303-519: aic_geometric_tolerances

```

```

ENTITY surface_replica

```

```

SUBTYPE OF (surface);
  parent_surface : surface;
  transformation : cartesian_transformation_operator_3d;
WHERE
  WR1: acyclic_surface_replica(SELF, parent_surface);
END_ENTITY; -- 10303-42: geometry_schema

ENTITY surface_texture_representation
  SUBTYPE OF (representation);
END_ENTITY; -- 10303-238: integrated_cnc_schema

ENTITY swept_surface
  SUPERTYPE OF (ONEOF(surface_of_linear_extrusion, surface_of_revolution))
  SUBTYPE OF (surface);
  swept_curve : curve;
END_ENTITY; -- 10303-42: geometry_schema

ENTITY symmetric_shape_aspect
  SUBTYPE OF (shape_aspect);
  INVERSE
    basis_relationships : SET [1:?] OF shape_aspect_relationship FOR
      relating_shape_aspect;
WHERE
  WR1: SIZEOF(QUERY (x <* SELF\symmetric_shape_aspect.basis_relationships
    | ('INTEGRATED_CNC_SCHEMA.CENTRE_OF_SYMMETRY' IN TYPEOF(x\
    shape_aspect_relationship.related_shape_aspect)))) >= 1;
END_ENTITY; -- 10303-47: shape_aspect_definition_schema

ENTITY symmetry_tolerance
  SUBTYPE OF (geometric_tolerance_with_datum_reference);
WHERE
  WR1: SIZEOF(SELF\geometric_tolerance_with_datum_reference.datum_system)
    <= 3;
END_ENTITY; -- 10303-519: aic_geometric_tolerances

ENTITY tangent
  SUBTYPE OF (derived_shape_aspect);
WHERE
  WR1: SIZEOF(SELF\derived_shape_aspect.deriving_relationships) = 1;
END_ENTITY; -- 10303-47: shape_aspect_definition_schema

ENTITY taper
  SUBTYPE OF (shape_aspect);
WHERE
  WR1: 'INTEGRATED_CNC_SCHEMA.FEATURE_COMPONENT_DEFINITION' IN TYPEOF(
    SELF.of_shape.definition);
  WR2: SELF.description IN [ 'angle taper', 'diameter taper',
    'directed taper' ];
  WR3: SIZEOF(QUERY (pd <* USEDIN(SELF,
    'INTEGRATED_CNC_SCHEMA.PROPERTY_DEFINITION.DEFINITION') | NOT
    (SIZEOF(QUERY (pdr <* USEDIN(pd, 'INTEGRATED_CNC_SCHEMA.' +
    'PROPERTY_DEFINITION_REPRESENTATION.DEFINITION') | (
    'INTEGRATED_CNC_SCHEMA.' +
    'SHAPE_REPRESENTATION_WITH_PARAMETERS' IN TYPEOF(pdr.

```

```

used_representation)))) = 1))) = 0;
WR4: SIZEOF(QUERY (pd <* USEDIN(SELF,
'INTEGRATED_CNC_SCHEMA.PROPERTY_DEFINITION.DEFINITION') | NOT
(SIZEOF(QUERY (impl_rep <* QUERY (pdr <* USEDIN(pd,
'INTEGRATED_CNC_SCHEMA.' +
'PROPERTY_DEFINITION_REPRESENTATION.DEFINITION') | (
'INTEGRATED_CNC_SCHEMA.' +
'SHAPE_REPRESENTATION_WITH_PARAMETERS' IN TYPEOF(pdr.
used_representation))) | NOT (SIZEOF(impl_rep.
used_representation.items) = 1))) = 0))) = 0;
WR5: NOT (SELF.description = 'angle taper') OR (SIZEOF(QUERY (pd <*
USEDIN(SELF,
'INTEGRATED_CNC_SCHEMA.PROPERTY_DEFINITION.DEFINITION') | NOT
(SIZEOF(QUERY (impl_rep <* QUERY (pdr <* USEDIN(pd,
'INTEGRATED_CNC_SCHEMA.' +
'PROPERTY_DEFINITION_REPRESENTATION.DEFINITION') | (
'INTEGRATED_CNC_SCHEMA.' +
'SHAPE_REPRESENTATION_WITH_PARAMETERS' IN TYPEOF(pdr.
used_representation))) | NOT (SIZEOF(QUERY (it <* impl_rep.
used_representation.items | (SIZEOF([
'INTEGRATED_CNC_SCHEMA.MEASURE_REPRESENTATION_ITEM',
'INTEGRATED_CNC_SCHEMA.PLANE_ANGLE_MEASURE_WITH_UNIT' ] *
TYPEOF(it)) = 2) AND (it.name = 'taper angle')) = 1))) = 0))
) = 0);
WR6: NOT (SELF.description = 'diameter taper') OR (SIZEOF(QUERY (pd <*
USEDIN(SELF,
'INTEGRATED_CNC_SCHEMA.PROPERTY_DEFINITION.DEFINITION') | NOT
(SIZEOF(QUERY (impl_rep <* QUERY (pdr <* USEDIN(pd,
'INTEGRATED_CNC_SCHEMA.' +
'PROPERTY_DEFINITION_REPRESENTATION.DEFINITION') | (
'INTEGRATED_CNC_SCHEMA.' +
'SHAPE_REPRESENTATION_WITH_PARAMETERS' IN TYPEOF(pdr.
used_representation))) | NOT (SIZEOF(QUERY (it <* impl_rep.
used_representation.items | (SIZEOF([
'INTEGRATED_CNC_SCHEMA.MEASURE_REPRESENTATION_ITEM',
'INTEGRATED_CNC_SCHEMA.LENGTH_MEASURE_WITH_UNIT' ] * TYPEOF(
it)) = 2) AND (it.name = 'final diameter')) = 1))) = 0))) =
0);
WR7: NOT (SELF.description = 'directed taper') OR (SIZEOF(QUERY (pd <*
USEDIN(SELF,
'INTEGRATED_CNC_SCHEMA.PROPERTY_DEFINITION.DEFINITION') | NOT
(SIZEOF(QUERY (impl_rep <* QUERY (pdr <* USEDIN(pd,
'INTEGRATED_CNC_SCHEMA.' +
'PROPERTY_DEFINITION_REPRESENTATION.DEFINITION') | (
'INTEGRATED_CNC_SCHEMA.' +
'SHAPE_REPRESENTATION_WITH_PARAMETERS' IN TYPEOF(pdr.
used_representation))) | NOT (SIZEOF(QUERY (it <* impl_rep.
used_representation.items | (SIZEOF([
'INTEGRATED_CNC_SCHEMA.MEASURE_REPRESENTATION_ITEM',
'INTEGRATED_CNC_SCHEMA.PLANE_ANGLE_MEASURE_WITH_UNIT' ] *
TYPEOF(it)) = 2) AND (it.name = 'angle')) = 1))) = 0))) = 0)
;
WR8: NOT (SELF.description = 'directed taper') OR (SIZEOF(QUERY (pd <*
USEDIN(SELF,

```



```

        'INTEGRATED_CNC_SCHEMA.PROPERTY_DEFINITION.DEFINITION')| NOT
        (SIZEOF(QUERY (pdr <* USEDIN(pd, 'INTEGRATED_CNC_SCHEMA.' +
        'PROPERTY_DEFINITION_REPRESENTATION.DEFINITION')| (
        'INTEGRATED_CNC_SCHEMA.DIRECTION_SHAPE_REPRESENTATION' IN
        TYPEOF(pdr.used_representation)) AND (pdr.used_representation
        .name = 'direction')))) = 1))) = 0);
END_ENTITY; -- 10303-522: aic_machining_feature

ENTITY tapping_operation
  SUBTYPE OF (drilling_type_operation);
  WHERE
  WR1: (SELF.description IN ['tapping','thread drilling']);

  WR2: NOT (SELF.description = 'tapping') OR
        ((verify_optional_action_property (SELF, 'compensation chuck') AND
        (verify_enumeration_action_property (SELF, 'compensation chuck',
        ['compensation chuck used', 'compensation chuck not used'])));

  WR3: NOT (SELF.description = 'thread drilling') OR
        ((verify_optional_action_property
        (SELF, 'helical movement on forward') AND
        (verify_enumeration_action_property
        (SELF, 'helical movement on forward',
        ['helical movement on forward', 'no helical movement on forward'])));
END_ENTITY; -- 10303-238: integrated_cnc_schema

ENTITY tee_profile
  SUBTYPE OF (shape_aspect);
  WHERE
  WR1: 'INTEGRATED_CNC_SCHEMA.FEATURE_COMPONENT_DEFINITION' IN TYPEOF(
        SELF.of_shape.definition);
  WR2: SIZEOF(QUERY (pd <* USEDIN(SELF,
        'INTEGRATED_CNC_SCHEMA.PROPERTY_DEFINITION.DEFINITION')| NOT
        (SIZEOF(QUERY (pdr <* USEDIN(pd, 'INTEGRATED_CNC_SCHEMA.' +
        'PROPERTY_DEFINITION_REPRESENTATION.DEFINITION')| (
        'INTEGRATED_CNC_SCHEMA.' +
        'SHAPE_REPRESENTATION_WITH_PARAMETERS' IN TYPEOF(pdr.
        used_representation)))) = 1))) = 0;
  WR3: SIZEOF(QUERY (pd <* USEDIN(SELF,
        'INTEGRATED_CNC_SCHEMA.PROPERTY_DEFINITION.DEFINITION')| NOT
        (SIZEOF(QUERY (impl_rep <* QUERY (pdr <* USEDIN(pd,
        'INTEGRATED_CNC_SCHEMA.' +
        'PROPERTY_DEFINITION_REPRESENTATION.DEFINITION')| (
        'INTEGRATED_CNC_SCHEMA.' +
        'SHAPE_REPRESENTATION_WITH_PARAMETERS' IN TYPEOF(pdr.
        used_representation)))| NOT (SIZEOF(impl_rep.
        used_representation.items) >= 9) AND (SIZEOF(impl_rep.
        used_representation.items) <= 10))) = 0))) = 0;
  WR4: SIZEOF(QUERY (pd <* USEDIN(SELF,
        'INTEGRATED_CNC_SCHEMA.PROPERTY_DEFINITION.DEFINITION')| (
        SIZEOF(QUERY (pdr <* USEDIN(pd, 'INTEGRATED_CNC_SCHEMA.' +
        'PROPERTY_DEFINITION_REPRESENTATION.DEFINITION')| (
        'INTEGRATED_CNC_SCHEMA.' +
        'SHAPE_REPRESENTATION_WITH_PARAMETERS' IN TYPEOF(pdr.

```

```

used_representation)) AND (SIZEOF(QUERY (srwp_i <* pdr.
used_representation.items| (((((((((srwp_i.name =
'orientation') OR (srwp_i.name = 'width')) OR (srwp_i.name =
'depth')) OR (srwp_i.name = 'cross bar width')) OR (srwp_i.
name = 'cross bar depth')) OR (srwp_i.name = 'first offset'))
OR (srwp_i.name = 'second offset')) OR (srwp_i.name =
'first angle')) OR (srwp_i.name = 'second angle')) OR (srwp_i
.name = 'radius')))) = SIZEOF(pdr.used_representation.items))
) = 1))) = 1;
WR5: SIZEOF(QUERY (pd <* USEDIN(SELF,
'INTEGRATED_CNC_SCHEMA.PROPERTY_DEFINITION.DEFINITION')| NOT
(SIZEOF(QUERY (impl_rep <* QUERY (pdr <* USEDIN(pd,
'INTEGRATED_CNC_SCHEMA.' +
'PROPERTY_DEFINITION_REPRESENTATION.DEFINITION')| (
'INTEGRATED_CNC_SCHEMA.' +
'SHAPE_REPRESENTATION_WITH_PARAMETERS' IN TYPEOF(pdr.
used_representation)))| NOT (SIZEOF(QUERY (it <* impl_rep.
used_representation.items| ('INTEGRATED_CNC_SCHEMA.PLACEMENT'
IN TYPEOF(it)) AND (it.name = 'orientation')))) = 1))) = 0)))
= 0;
WR6: SIZEOF(QUERY (pd <* USEDIN(SELF,
'INTEGRATED_CNC_SCHEMA.PROPERTY_DEFINITION.DEFINITION')| NOT
(SIZEOF(QUERY (impl_rep <* QUERY (pdr <* USEDIN(pd,
'INTEGRATED_CNC_SCHEMA.' +
'PROPERTY_DEFINITION_REPRESENTATION.DEFINITION')| (
'INTEGRATED_CNC_SCHEMA.' +
'SHAPE_REPRESENTATION_WITH_PARAMETERS' IN TYPEOF(pdr.
used_representation)))| NOT (SIZEOF(QUERY (it <* impl_rep.
used_representation.items| (SIZEOF([
'INTEGRATED_CNC_SCHEMA.MEASURE_REPRESENTATION_ITEM',
'INTEGRATED_CNC_SCHEMA.LENGTH_MEASURE_WITH_UNIT' ] * TYPEOF(
it)) = 2) AND (it.name = 'width')))) = 1))) = 0))) = 0;
WR7: SIZEOF(QUERY (pd <* USEDIN(SELF,
'INTEGRATED_CNC_SCHEMA.PROPERTY_DEFINITION.DEFINITION')| NOT
(SIZEOF(QUERY (impl_rep <* QUERY (pdr <* USEDIN(pd,
'INTEGRATED_CNC_SCHEMA.' +
'PROPERTY_DEFINITION_REPRESENTATION.DEFINITION')| (
'INTEGRATED_CNC_SCHEMA.' +
'SHAPE_REPRESENTATION_WITH_PARAMETERS' IN TYPEOF(pdr.
used_representation)))| NOT (SIZEOF(QUERY (it <* impl_rep.
used_representation.items| (SIZEOF([
'INTEGRATED_CNC_SCHEMA.MEASURE_REPRESENTATION_ITEM',
'INTEGRATED_CNC_SCHEMA.LENGTH_MEASURE_WITH_UNIT' ] * TYPEOF(
it)) = 2) AND (it.name = 'depth')))) = 1))) = 0))) = 0;
WR8: SIZEOF(QUERY (pd <* USEDIN(SELF,
'INTEGRATED_CNC_SCHEMA.PROPERTY_DEFINITION.DEFINITION')| NOT
(SIZEOF(QUERY (impl_rep <* QUERY (pdr <* USEDIN(pd,
'INTEGRATED_CNC_SCHEMA.' +
'PROPERTY_DEFINITION_REPRESENTATION.DEFINITION')| (
'INTEGRATED_CNC_SCHEMA.' +
'SHAPE_REPRESENTATION_WITH_PARAMETERS' IN TYPEOF(pdr.
used_representation)))| NOT (SIZEOF(QUERY (it <* impl_rep.
used_representation.items| (SIZEOF([
'INTEGRATED_CNC_SCHEMA.MEASURE_REPRESENTATION_ITEM',

```

```

        'INTEGRATED_CNC_SCHEMA.LENGTH_MEASURE_WITH_UNIT' ] * TYPEOF(
it)) = 2) AND (it.name = 'cross bar width')) = 1))) = 0))) =
0;
WR9: SIZEOF(QUERY (pd <* USEDIN(SELF,
    'INTEGRATED_CNC_SCHEMA.PROPERTY_DEFINITION.DEFINITION')| NOT
(SIZEOF(QUERY (impl_rep <* QUERY (pdr <* USEDIN(pd,
    'INTEGRATED_CNC_SCHEMA.' +
    'PROPERTY_DEFINITION_REPRESENTATION.DEFINITION')| (
    'INTEGRATED_CNC_SCHEMA.' +
    'SHAPE_REPRESENTATION_WITH_PARAMETERS' IN TYPEOF(pdr.
used_representation)))| NOT (SIZEOF(QUERY (it <* impl_rep.
used_representation.items| (SIZEOF([
    'INTEGRATED_CNC_SCHEMA.MEASURE_REPRESENTATION_ITEM',
    'INTEGRATED_CNC_SCHEMA.LENGTH_MEASURE_WITH_UNIT' ] * TYPEOF(
it)) = 2) AND (it.name = 'cross bar depth')) = 1))) = 0))) =
0;
WR10: SIZEOF(QUERY (pd <* USEDIN(SELF,
    'INTEGRATED_CNC_SCHEMA.PROPERTY_DEFINITION.DEFINITION')| NOT
(SIZEOF(QUERY (impl_rep <* QUERY (pdr <* USEDIN(pd,
    'INTEGRATED_CNC_SCHEMA.' +
    'PROPERTY_DEFINITION_REPRESENTATION.DEFINITION')| (
    'INTEGRATED_CNC_SCHEMA.' +
    'SHAPE_REPRESENTATION_WITH_PARAMETERS' IN TYPEOF(pdr.
used_representation)))| NOT (SIZEOF(QUERY (it <* impl_rep.
used_representation.items| (SIZEOF([
    'INTEGRATED_CNC_SCHEMA.MEASURE_REPRESENTATION_ITEM',
    'INTEGRATED_CNC_SCHEMA.LENGTH_MEASURE_WITH_UNIT' ] * TYPEOF(
it)) = 2) AND (it.name = 'first offset')) = 1))) = 0))) = 0;
WR11: SIZEOF(QUERY (pd <* USEDIN(SELF,
    'INTEGRATED_CNC_SCHEMA.PROPERTY_DEFINITION.DEFINITION')| NOT
(SIZEOF(QUERY (impl_rep <* QUERY (pdr <* USEDIN(pd,
    'INTEGRATED_CNC_SCHEMA.' +
    'PROPERTY_DEFINITION_REPRESENTATION.DEFINITION')| (
    'INTEGRATED_CNC_SCHEMA.' +
    'SHAPE_REPRESENTATION_WITH_PARAMETERS' IN TYPEOF(pdr.
used_representation)))| NOT (SIZEOF(QUERY (it <* impl_rep.
used_representation.items| (SIZEOF([
    'INTEGRATED_CNC_SCHEMA.MEASURE_REPRESENTATION_ITEM',
    'INTEGRATED_CNC_SCHEMA.LENGTH_MEASURE_WITH_UNIT' ] * TYPEOF(
it)) = 2) AND (it.name = 'second offset')) = 1))) = 0))) = 0
;
WR12: SIZEOF(QUERY (pd <* USEDIN(SELF,
    'INTEGRATED_CNC_SCHEMA.PROPERTY_DEFINITION.DEFINITION')| NOT
(SIZEOF(QUERY (impl_rep <* QUERY (pdr <* USEDIN(pd,
    'INTEGRATED_CNC_SCHEMA.' +
    'PROPERTY_DEFINITION_REPRESENTATION.DEFINITION')| (
    'INTEGRATED_CNC_SCHEMA.' +
    'SHAPE_REPRESENTATION_WITH_PARAMETERS' IN TYPEOF(pdr.
used_representation)))| NOT (SIZEOF(QUERY (it <* impl_rep.
used_representation.items| (SIZEOF([
    'INTEGRATED_CNC_SCHEMA.MEASURE_REPRESENTATION_ITEM',
    'INTEGRATED_CNC_SCHEMA.PLANE_ANGLE_MEASURE_WITH_UNIT' ] *
TYPEOF(it)) = 2) AND (it.name = 'first angle')) = 1))) = 0))
) = 0;

```

```

WR13: SIZEOF(QUERY (pd <* USEDIN(SELF,
    'INTEGRATED_CNC_SCHEMA.PROPERTY_DEFINITION.DEFINITION')| NOT
    (SIZEOF(QUERY (impl_rep <* QUERY (pdr <* USEDIN(pd,
    'INTEGRATED_CNC_SCHEMA.' +
    'PROPERTY_DEFINITION_REPRESENTATION.DEFINITION')| (
    'INTEGRATED_CNC_SCHEMA.' +
    'SHAPE_REPRESENTATION_WITH_PARAMETERS' IN TYPEOF(pdr.
    used_representation)))| NOT (SIZEOF(QUERY (it <* impl_rep.
    used_representation.items| (SIZEOF([
    'INTEGRATED_CNC_SCHEMA.MEASURE_REPRESENTATION_ITEM',
    'INTEGRATED_CNC_SCHEMA.PLANE_ANGLE_MEASURE_WITH_UNIT' ] *
    TYPEOF(it)) = 2) AND (it.name = 'second angle')) = 1))) = 0)
    )) = 0;

WR14: SIZEOF(QUERY (pd <* USEDIN(SELF,
    'INTEGRATED_CNC_SCHEMA.PROPERTY_DEFINITION.DEFINITION')| NOT
    (SIZEOF(QUERY (impl_rep <* QUERY (pdr <* USEDIN(pd,
    'INTEGRATED_CNC_SCHEMA.' +
    'PROPERTY_DEFINITION_REPRESENTATION.DEFINITION')| (
    'INTEGRATED_CNC_SCHEMA.' +
    'SHAPE_REPRESENTATION_WITH_PARAMETERS' IN TYPEOF(pdr.
    used_representation)))| NOT (SIZEOF(QUERY (it <* impl_rep.
    used_representation.items| (SIZEOF([
    'INTEGRATED_CNC_SCHEMA.MEASURE_REPRESENTATION_ITEM',
    'INTEGRATED_CNC_SCHEMA.LENGTH_MEASURE_WITH_UNIT' ] * TYPEOF(
    it)) = 2) AND (it.name = 'radius')) <= 1))) = 0))) = 0;

WR15: SIZEOF(QUERY (pd <* USEDIN(SELF,
    'INTEGRATED_CNC_SCHEMA.PROPERTY_DEFINITION.' + 'DEFINITION')|
    NOT (SIZEOF(QUERY (pdr <* USEDIN(pd,
    'INTEGRATED_CNC_SCHEMA.' +
    'PROPERTY_DEFINITION_REPRESENTATION.DEFINITION')| (
    'INTEGRATED_CNC_SCHEMA.PLANAR_SHAPE_REPRESENTATION' IN TYPEOF
    (pdr.used_representation)) AND (pdr.used_representation.name
    = 'profile limit')) <= 1))) = 0;
END_ENTITY; -- 10303-522: aic_machining_feature

```

ENTITY thread

SUBTYPE OF (feature\_definition);

WHERE

```

WR1: SIZEOF(QUERY (pd <* USEDIN(SELF,
    'INTEGRATED_CNC_SCHEMA.PROPERTY_DEFINITION.DEFINITION')| (
    SIZEOF(QUERY (pdr <* USEDIN(pd, 'INTEGRATED_CNC_SCHEMA.' +
    'PROPERTY_DEFINITION_REPRESENTATION.DEFINITION')| ((
    'INTEGRATED_CNC_SCHEMA.' +
    'SHAPE_REPRESENTATION_WITH_PARAMETERS' IN TYPEOF(pdr.
    used_representation)) AND (8 <= SIZEOF(pdr.
    used_representation.items))) AND (SIZEOF(pdr.
    used_representation.items) <= 11))) = 1))) = 1;

WR2: SIZEOF(QUERY (pd <* USEDIN(SELF,
    'INTEGRATED_CNC_SCHEMA.PROPERTY_DEFINITION.DEFINITION')| NOT
    (SIZEOF(QUERY (impl_rep <* QUERY (pdr <* USEDIN(pd,
    'INTEGRATED_CNC_SCHEMA.' +
    'PROPERTY_DEFINITION_REPRESENTATION.DEFINITION')| (
    'INTEGRATED_CNC_SCHEMA.' +
    'SHAPE_REPRESENTATION_WITH_PARAMETERS' IN TYPEOF(pdr.

```

```

used_representation)))| NOT (SIZEOF(QUERY (it <* impl_rep.
used_representation.items| (SIZEOF([
'INTEGRATED_CNC_SCHEMA.MEASURE_REPRESENTATION_ITEM',
'INTEGRATED_CNC_SCHEMA.LENGTH_MEASURE_WITH_UNIT' ] * TYPEOF(
it)) = 2) AND (it.name = 'major diameter')) = 1))) = 0))) =
0;
WR3: SIZEOF(QUERY (pd <* USEDIN(SELF,
'INTEGRATED_CNC_SCHEMA.PROPERTY_DEFINITION.DEFINITION')| NOT
(SIZEOF(QUERY (impl_rep <* QUERY (pdr <* USEDIN(pd,
'INTEGRATED_CNC_SCHEMA.' +
'PROPERTY_DEFINITION_REPRESENTATION.DEFINITION')| (
'INTEGRATED_CNC_SCHEMA.' +
'SHAPE_REPRESENTATION_WITH_PARAMETERS' IN TYPEOF(pdr.
used_representation)))| NOT (SIZEOF(QUERY (it <* impl_rep.
used_representation.items| (SIZEOF([
'INTEGRATED_CNC_SCHEMA.MEASURE_REPRESENTATION_ITEM',
'INTEGRATED_CNC_SCHEMA.LENGTH_MEASURE_WITH_UNIT' ] * TYPEOF(
it)) = 2) AND (it.name = 'minor diameter')) <= 1))) = 0))) =
0;
WR4: SIZEOF(QUERY (pd <* USEDIN(SELF,
'INTEGRATED_CNC_SCHEMA.PROPERTY_DEFINITION.DEFINITION')| NOT
(SIZEOF(QUERY (impl_rep <* QUERY (pdr <* USEDIN(pd,
'INTEGRATED_CNC_SCHEMA.' +
'PROPERTY_DEFINITION_REPRESENTATION.DEFINITION')| (
'INTEGRATED_CNC_SCHEMA.' +
'SHAPE_REPRESENTATION_WITH_PARAMETERS' IN TYPEOF(pdr.
used_representation)))| NOT (SIZEOF(QUERY (it <* impl_rep.
used_representation.items| (SIZEOF([
'INTEGRATED_CNC_SCHEMA.MEASURE_REPRESENTATION_ITEM',
'INTEGRATED_CNC_SCHEMA.LENGTH_MEASURE_WITH_UNIT' ] * TYPEOF(
it)) = 2) AND (it.name = 'pitch diameter')) <= 1))) = 0))) =
0;
WR5: SIZEOF(QUERY (pd <* USEDIN(SELF,
'INTEGRATED_CNC_SCHEMA.PROPERTY_DEFINITION.DEFINITION')| NOT
(SIZEOF(QUERY (impl_rep <* QUERY (pdr <* USEDIN(pd,
'INTEGRATED_CNC_SCHEMA.' +
'PROPERTY_DEFINITION_REPRESENTATION.DEFINITION')| (
'INTEGRATED_CNC_SCHEMA.' +
'SHAPE_REPRESENTATION_WITH_PARAMETERS' IN TYPEOF(pdr.
used_representation)))| NOT (SIZEOF(QUERY (it <* impl_rep.
used_representation.items| (SIZEOF([
'INTEGRATED_CNC_SCHEMA.MEASURE_REPRESENTATION_ITEM',
'INTEGRATED_CNC_SCHEMA.RATIO_MEASURE_WITH_UNIT' ] * TYPEOF(it
)) = 2) AND (it.name = 'number of threads')) = 1))) = 0))) =
0;
WR6: SIZEOF(QUERY (pd <* USEDIN(SELF,
'INTEGRATED_CNC_SCHEMA.PROPERTY_DEFINITION.DEFINITION')| NOT
(SIZEOF(QUERY (impl_rep <* QUERY (pdr <* USEDIN(pd,
'INTEGRATED_CNC_SCHEMA.' +
'PROPERTY_DEFINITION_REPRESENTATION.DEFINITION')| (
'INTEGRATED_CNC_SCHEMA.' +
'SHAPE_REPRESENTATION_WITH_PARAMETERS' IN TYPEOF(pdr.
used_representation)))| NOT (SIZEOF(QUERY (it <* impl_rep.
used_representation.items| (

```

```

        'INTEGRATED_CNC_SCHEMA.DESRIPTIVE_REPRESENTATION_ITEM' IN
        TYPEOF(it)) AND (it.name = 'fit class')) = 1))) = 0))) = 0;
WR7: SIZEOF(QUERY (pd <* USEDIN(SELF,
        'INTEGRATED_CNC_SCHEMA.PROPERTY_DEFINITION.DEFINITION')| NOT
        (SIZEOF(QUERY (impl_rep <* QUERY (pdr <* USEDIN(pd,
        'INTEGRATED_CNC_SCHEMA.' +
        'PROPERTY_DEFINITION_REPRESENTATION.DEFINITION')| (
        'INTEGRATED_CNC_SCHEMA.' +
        'SHAPE_REPRESENTATION_WITH_PARAMETERS' IN TYPEOF(pdr.
        used_representation)))| NOT (SIZEOF(QUERY (it <* impl_rep.
        used_representation.items| (
        'INTEGRATED_CNC_SCHEMA.DESRIPTIVE_REPRESENTATION_ITEM' IN
        TYPEOF(it)) AND (it.name = 'form')) = 1))) = 0))) = 0;
WR8: SIZEOF(QUERY (pd <* USEDIN(SELF,
        'INTEGRATED_CNC_SCHEMA.PROPERTY_DEFINITION.DEFINITION')| NOT
        (SIZEOF(QUERY (impl_rep <* QUERY (pdr <* USEDIN(pd,
        'INTEGRATED_CNC_SCHEMA.' +
        'PROPERTY_DEFINITION_REPRESENTATION.DEFINITION')| (
        'INTEGRATED_CNC_SCHEMA.' +
        'SHAPE_REPRESENTATION_WITH_PARAMETERS' IN TYPEOF(pdr.
        used_representation)))| NOT (SIZEOF(QUERY (it <* impl_rep.
        used_representation.items| ((
        'INTEGRATED_CNC_SCHEMA.DESRIPTIVE_REPRESENTATION_ITEM' IN
        TYPEOF(it)) AND (it.name = 'hand')) AND (it.description IN [
        'left', 'right' ]))) = 1))) = 0))) = 0;
WR9: SIZEOF(QUERY (pd <* USEDIN(SELF,
        'INTEGRATED_CNC_SCHEMA.PROPERTY_DEFINITION.DEFINITION')| NOT
        (SIZEOF(QUERY (impl_rep <* QUERY (pdr <* USEDIN(pd,
        'INTEGRATED_CNC_SCHEMA.' +
        'PROPERTY_DEFINITION_REPRESENTATION.DEFINITION')| (
        'INTEGRATED_CNC_SCHEMA.' +
        'SHAPE_REPRESENTATION_WITH_PARAMETERS' IN TYPEOF(pdr.
        used_representation)))| NOT (SIZEOF(QUERY (it <* impl_rep.
        used_representation.items| (
        'INTEGRATED_CNC_SCHEMA.DESRIPTIVE_REPRESENTATION_ITEM' IN
        TYPEOF(it)) AND (it.name = 'qualifier')) <= 1))) = 0))) = 0;
WR10: SIZEOF(QUERY (pd <* USEDIN(SELF,
        'INTEGRATED_CNC_SCHEMA.PROPERTY_DEFINITION.DEFINITION')| NOT
        (SIZEOF(QUERY (impl_rep <* QUERY (pdr <* USEDIN(pd,
        'INTEGRATED_CNC_SCHEMA.' +
        'PROPERTY_DEFINITION_REPRESENTATION.DEFINITION')| (
        'INTEGRATED_CNC_SCHEMA.' +
        'SHAPE_REPRESENTATION_WITH_PARAMETERS' IN TYPEOF(pdr.
        used_representation)))| NOT (SIZEOF(QUERY (it <* impl_rep.
        used_representation.items| ((
        'INTEGRATED_CNC_SCHEMA.DESRIPTIVE_REPRESENTATION_ITEM' IN
        TYPEOF(it)) AND (it.name = 'thread side')) AND ((it.
        description = 'internal') OR (it.description = 'external'))))
        = 1))) = 0))) = 0;
WR11: SIZEOF(QUERY (pd <* USEDIN(SELF,
        'INTEGRATED_CNC_SCHEMA.PROPERTY_DEFINITION.DEFINITION')| NOT
        (SIZEOF(QUERY (impl_rep <* QUERY (pdr <* USEDIN(pd,
        'INTEGRATED_CNC_SCHEMA.' +
        'PROPERTY_DEFINITION_REPRESENTATION.DEFINITION')| (

```

```

'INTEGRATED_CNC_SCHEMA.' +
'SHAPE_REPRESENTATION_WITH_PARAMETERS' IN TYPEOF(pdr.
used_representation)))| NOT (SIZEOF(QUERY (it <* impl_rep.
used_representation.items| (SIZEOF([
'INTEGRATED_CNC_SCHEMA.MEASURE_REPRESENTATION_ITEM',
'INTEGRATED_CNC_SCHEMA.LENGTH_MEASURE_WITH_UNIT' ] * TYPEOF(
it)) = 2) AND (it.name = 'crest')) <= 1))) = 0))) = 0;
WR12: SIZEOF(QUERY (pds <* QUERY (pd <* USEDIN(SELF,
'INTEGRATED_CNC_SCHEMA.PROPERTY_DEFINITION.DEFINITION')| (
'INTEGRATED_CNC_SCHEMA.PRODUCT_DEFINITION_SHAPE' IN TYPEOF(pd
)))| NOT (SIZEOF(QUERY (sa_occ <* USEDIN(pds,
'INTEGRATED_CNC_SCHEMA.SHAPE_ASPECT.OF_SHAPE')| (sa_occ.
description = 'partial area occurrence') AND (SIZEOF(QUERY (
sdr <* QUERY (sar <* USEDIN(sa_occ,
'INTEGRATED_CNC_SCHEMA.SHAPE_ASPECT_RELATIONSHIP.' +
'RELATED_SHAPE_ASPECT')| (sar.description =
'applied area usage') AND (
'INTEGRATED_CNC_SCHEMA.SHAPE_DEFINING_RELATIONSHIP' IN TYPEOF
(sar)))| ('INTEGRATED_CNC_SCHEMA.APPLIED_AREA' IN TYPEOF(sdr.
relating_shape_aspect)))) = 1))) = 1))) = 0;
WR13: SIZEOF(QUERY (pds <* QUERY (pd <* USEDIN(SELF,
'INTEGRATED_CNC_SCHEMA.PROPERTY_DEFINITION.DEFINITION')| (
'INTEGRATED_CNC_SCHEMA.PRODUCT_DEFINITION_SHAPE' IN TYPEOF(pd
)))| NOT (SIZEOF(QUERY (sa_occ <* USEDIN(pds,
'INTEGRATED_CNC_SCHEMA.SHAPE_ASPECT.OF_SHAPE')| (SIZEOF(QUERY
(sdr <* QUERY (sar <* USEDIN(sa_occ,
'INTEGRATED_CNC_SCHEMA.SHAPE_ASPECT_RELATIONSHIP.' +
'RELATED_SHAPE_ASPECT')| (sar.description = 'applied shape')
AND ('INTEGRATED_CNC_SCHEMA.SHAPE_DEFINING_RELATIONSHIP' IN
TYPEOF(sar)))| ('INTEGRATED_CNC_SCHEMA.SHAPE_ASPECT' IN
TYPEOF(sdr.relating_shape_aspect)))) = 1))) = 1))) = 0;
WR14: SIZEOF(QUERY (pd <* USEDIN(SELF,
'INTEGRATED_CNC_SCHEMA.PROPERTY_DEFINITION.DEFINITION')| NOT
(SIZEOF(QUERY (impl_rep <* QUERY (pdr <* USEDIN(pd,
'INTEGRATED_CNC_SCHEMA.' +
'PROPERTY_DEFINITION_REPRESENTATION.DEFINITION')| (
'INTEGRATED_CNC_SCHEMA.' +
'SHAPE_REPRESENTATION_WITH_PARAMETERS' IN TYPEOF(pdr.
used_representation)))| NOT (SIZEOF(QUERY (it <* impl_rep.
used_representation.items| (
'INTEGRATED_CNC_SCHEMA.DESCRPTIVE_REPRESENTATION_ITEM' IN
TYPEOF(it)) AND (it.name = 'fit class 2')) <= 1))) = 0))) =
0;
WR15: SIZEOF(QUERY (pd <* USEDIN(SELF,
'INTEGRATED_CNC_SCHEMA.PROPERTY_DEFINITION.DEFINITION')| NOT
(SIZEOF(QUERY (impl_rep <* QUERY (pdr <* USEDIN(pd,
'INTEGRATED_CNC_SCHEMA.' +
'PROPERTY_DEFINITION_REPRESENTATION.DEFINITION')| (
'INTEGRATED_CNC_SCHEMA.' +
'SHAPE_REPRESENTATION_WITH_PARAMETERS' IN TYPEOF(pdr.
used_representation)))| NOT (SIZEOF(QUERY (it <* impl_rep.
used_representation.items| (SIZEOF([
'INTEGRATED_CNC_SCHEMA.MEASURE_REPRESENTATION_ITEM',
'INTEGRATED_CNC_SCHEMA.LENGTH_MEASURE_WITH_UNIT' ] * TYPEOF(

```

```

        it)) = 2) AND (it.name = 'nominal size')) (<= 1))) = 0))) = 0
    ;
WR16: SIZEOF(QUERY (pds <* QUERY (pd <* USEDIN(SELF,
    'INTEGRATED_CNC_SCHEMA.PROPERTY_DEFINITION.DEFINITION') | (
    'INTEGRATED_CNC_SCHEMA.PRODUCT_DEFINITION_SHAPE' IN TYPEOF(pd
    ))) | NOT (SIZEOF(QUERY (sa_occ <* USEDIN(pds,
    'INTEGRATED_CNC_SCHEMA.SHAPE_ASPECT.OF_SHAPE') | (sa_occ.
    description = 'thread runout') AND (SIZEOF(QUERY (sdr <*
    QUERY (sar <* USEDIN(sa_occ,
    'INTEGRATED_CNC_SCHEMA.SHAPE_ASPECT_RELATIONSHIP.' +
    'RELATED_SHAPE_ASPECT') | (sar.description =
    'thread runout usage') AND (
    'INTEGRATED_CNC_SCHEMA.SHAPE_DEFINING_RELATIONSHIP' IN TYPEOF
    (sar))) | ('INTEGRATED_CNC_SCHEMA.THREAD_RUNOUT' IN TYPEOF(sdr
    .relating_shape_aspect)))) (<= 1))) = 1))) = 0;
END_ENTITY; -- 10303-522: aic_machining_feature

```

```

ENTITY thread_runout
  SUBTYPE OF (shape_aspect);
  WHERE
    WR1: 'INTEGRATED_CNC_SCHEMA.PRODUCT_DEFINITION_SHAPE' IN TYPEOF(SELF.
    of_shape);
    WR2: SIZEOF(QUERY (pd <* USEDIN(SELF,
    'INTEGRATED_CNC_SCHEMA.PROPERTY_DEFINITION.DEFINITION') | NOT
    (SIZEOF(QUERY (pdr <* USEDIN(pd, 'INTEGRATED_CNC_SCHEMA.' +
    'PROPERTY_DEFINITION_REPRESENTATION.DEFINITION') | (
    'INTEGRATED_CNC_SCHEMA.' +
    'SHAPE_REPRESENTATION_WITH_PARAMETERS' IN TYPEOF(pdr.
    used_representation)))) = 1))) = 0;
    WR3: SIZEOF(QUERY (pd <* USEDIN(SELF,
    'INTEGRATED_CNC_SCHEMA.PROPERTY_DEFINITION.DEFINITION') | NOT
    (SIZEOF(QUERY (impl_rep <* QUERY (pdr <* USEDIN(pd,
    'INTEGRATED_CNC_SCHEMA.' +
    'PROPERTY_DEFINITION_REPRESENTATION.DEFINITION') | (
    'INTEGRATED_CNC_SCHEMA.' +
    'SHAPE_REPRESENTATION_WITH_PARAMETERS' IN TYPEOF(pdr.
    used_representation))) | NOT (SIZEOF(impl_rep.
    used_representation.items) = 3))) = 0))) = 0;
    WR4: SIZEOF(QUERY (pd <* USEDIN(SELF,
    'INTEGRATED_CNC_SCHEMA.PROPERTY_DEFINITION.DEFINITION') | (
    SIZEOF(QUERY (pdr <* USEDIN(pd, 'INTEGRATED_CNC_SCHEMA.' +
    'PROPERTY_DEFINITION_REPRESENTATION.DEFINITION') | (
    'INTEGRATED_CNC_SCHEMA.' +
    'SHAPE_REPRESENTATION_WITH_PARAMETERS' IN TYPEOF(pdr.
    used_representation)) AND (SIZEOF(QUERY (srwp_i <* pdr.
    used_representation.items | NOT (srwp_i.name IN [
    'length of runout', 'pitch or dimension', 'included or extra'
    ]))) > 0))) = 0))) = 0;
    WR5: SIZEOF(QUERY (pd <* USEDIN(SELF,
    'INTEGRATED_CNC_SCHEMA.PROPERTY_DEFINITION.DEFINITION') | NOT
    (SIZEOF(QUERY (impl_rep <* QUERY (pdr <* USEDIN(pd,
    'INTEGRATED_CNC_SCHEMA.' +
    'PROPERTY_DEFINITION_REPRESENTATION.DEFINITION') | (
    'INTEGRATED_CNC_SCHEMA.' +

```



```

        'SHAPE_REPRESENTATION_WITH_PARAMETERS' IN TYPEOF(pdr.
used_representation)))| NOT (SIZEOF(QUERY (it <* impl_rep.
used_representation.items| (SIZEOF([
        'INTEGRATED_CNC_SCHEMA.MEASURE_REPRESENTATION_ITEM',
        'INTEGRATED_CNC_SCHEMA.LENGTH_MEASURE_WITH_UNIT' ] * TYPEOF(
it)) = 2) AND (it.name = 'length of runout')) = 1))) = 0)))
<= 1;
WR6: SIZEOF(QUERY (pd <* USEDIN(SELF,
        'INTEGRATED_CNC_SCHEMA.PROPERTY_DEFINITION.DEFINITION')| NOT
(SIZEOF(QUERY (impl_rep <* QUERY (pdr <* USEDIN(pd,
        'INTEGRATED_CNC_SCHEMA.' +
        'PROPERTY_DEFINITION_REPRESENTATION.DEFINITION')| (
        'INTEGRATED_CNC_SCHEMA.' +
        'SHAPE_REPRESENTATION_WITH_PARAMETERS' IN TYPEOF(pdr.
used_representation)))| NOT (SIZEOF(QUERY (it <* impl_rep.
used_representation.items| ((
        'INTEGRATED_CNC_SCHEMA.DESRIPTIVE_REPRESENTATION_ITEM' IN
TYPEOF(it)) AND (it.name = 'pitch or dimension')) AND (it.
description IN [ 'pitch', 'pitch or dimension' ]))) = 1))) =
0))) = 0;
WR7: SIZEOF(QUERY (pd <* USEDIN(SELF,
        'INTEGRATED_CNC_SCHEMA.PROPERTY_DEFINITION.DEFINITION')| NOT
(SIZEOF(QUERY (impl_rep <* QUERY (pdr <* USEDIN(pd,
        'INTEGRATED_CNC_SCHEMA.' +
        'PROPERTY_DEFINITION_REPRESENTATION.DEFINITION')| (
        'INTEGRATED_CNC_SCHEMA.' +
        'SHAPE_REPRESENTATION_WITH_PARAMETERS' IN TYPEOF(pdr.
used_representation)))| NOT (SIZEOF(QUERY (it <* impl_rep.
used_representation.items| ((
        'INTEGRATED_CNC_SCHEMA.DESRIPTIVE_REPRESENTATION_ITEM' IN
TYPEOF(it)) AND (it.name = 'included or extra')) AND (it.
description IN [ 'included', 'extra' ]))) = 1))) = 0))) = 0;
END_ENTITY; -- 10303-522: aic_machining_feature

ENTITY threading_turning_operation
  SUBTYPE OF (turning_type_operation);
  WHERE
  WR1: (SELF.description IN ['roughing','finishing']);

  WR2: (verify_optional_action_property (SELF, 'allowance')) AND
        (verify_length_measure_action_property (SELF, 'allowance'));

  WR3: NOT (SELF.description = 'roughing') OR
        (verify_required_action_property (SELF, 'allowance'));
END_ENTITY; -- 10303-238: integrated_cnc_schema

ENTITY time_measure_with_unit
  SUBTYPE OF (measure_with_unit);
  WHERE
  WR1: 'INTEGRATED_CNC_SCHEMA.TIME_UNIT' IN TYPEOF(SELF\measure_with_unit
        .unit_component);
END_ENTITY; -- 10303-41: measure_schema

ENTITY time_unit

```

ISO 10303-238:2007(E)

```

SUBTYPE OF (named_unit);
WHERE
  WR1: (((((SELF\named_unit.dimensions.length_exponent = 0.0) AND (SELF\named_unit.dimensions.mass_exponent = 0.0)) AND (SELF\named_unit.dimensions.time_exponent = 1.0)) AND (SELF\named_unit.dimensions.electric_current_exponent = 0.0)) AND (SELF\named_unit.dimensions.thermodynamic_temperature_exponent = 0.0)) AND (SELF\named_unit.dimensions.amount_of_substance_exponent = 0.0)) AND (SELF\named_unit.dimensions.luminous_intensity_exponent = 0.0);
END_ENTITY; -- 10303-41: measure_schema

```

```

ENTITY tolerance_value;
  lower_bound : measure_with_unit;
  upper_bound : measure_with_unit;
WHERE
  WR1: upper_bound\measure_with_unit.value_component > lower_bound\measure_with_unit.value_component;
  WR2: upper_bound\measure_with_unit.unit_component = lower_bound\measure_with_unit.unit_component;
END_ENTITY; -- 10303-47: shape_tolerance_schema

```

```

ENTITY tolerance_zone
  SUBTYPE OF (shape_aspect);
  defining_tolerance : SET [1:?] OF geometric_tolerance;
  form : tolerance_zone_form;
END_ENTITY; -- 10303-47: shape_tolerance_schema

```

```

ENTITY tolerance_zone_definition
  SUPERTYPE OF (ONEOF(projected_zone_definition, runout_zone_definition));
  zone : tolerance_zone;
  boundaries : SET [1:?] OF shape_aspect;
END_ENTITY; -- 10303-47: shape_tolerance_schema

```

```

ENTITY tolerance_zone_form;
  name : label;
END_ENTITY; -- 10303-47: shape_tolerance_schema

```

```

ENTITY topological_representation_item
  SUPERTYPE OF (ONEOF(vertex, edge, face_bound, face, vertex_shell, wire_shell, connected_edge_set, connected_face_set, loop ANDOR path))
  SUBTYPE OF (representation_item);
END_ENTITY; -- 10303-42: topology_schema

```

```

ENTITY toroidal_surface
  SUBTYPE OF (elementary_surface);
  major_radius : positive_length_measure;
  minor_radius : positive_length_measure;
END_ENTITY; -- 10303-42: geometry_schema

```

```

ENTITY total_runout_tolerance
  SUBTYPE OF (geometric_tolerance_with_datum_reference);
WHERE
  WR1: SIZEOF(SELF\geometric_tolerance_with_datum_reference.datum_system)

```

```

        <= 2;
END_ENTITY; -- 10303-519: aic_geometric_tolerances

ENTITY transition_feature
  SUPERTYPE OF (ONEOF(chamfer, edge_round, fillet))
  SUBTYPE OF (shape_aspect);
  WHERE
    WR1: SIZEOF([ 'INTEGRATED_CNC_SCHEMA.PRODUCT_DEFINITION',
                  'INTEGRATED_CNC_SCHEMA.COMPOUND_FEATURE' ] * TYPEOF(SELF.
                    of_shape.definition)) = 1;
    WR2: SIZEOF([ 'INTEGRATED_CNC_SCHEMA.CHAMFER',
                  'INTEGRATED_CNC_SCHEMA.EDGE_ROUND',
                  'INTEGRATED_CNC_SCHEMA.FILLET' ] * TYPEOF(SELF)) = 1;
END_ENTITY; -- 10303-522: aic_machining_feature

ENTITY trimmed_curve
  SUBTYPE OF (bounded_curve);
  basis_curve      : curve;
  trim_1           : SET [1:2] OF trimming_select;
  trim_2           : SET [1:2] OF trimming_select;
  sense_agreement  : BOOLEAN;
  master_representation : trimming_preference;
  WHERE
    WR1: (HIINDEX(trim_1) = 1) OR (TYPEOF(trim_1[1]) <> TYPEOF(trim_1[2]));
    WR2: (HIINDEX(trim_2) = 1) OR (TYPEOF(trim_2[1]) <> TYPEOF(trim_2[2]));
END_ENTITY; -- 10303-42: geometry_schema

ENTITY turned_knurl
  SUBTYPE OF (feature_definition);
  WHERE
    WR1: SELF\characterized_object.description IN [ 'diamond', 'diagonal',
              'straight' ];
    WR2: SIZEOF(QUERY (pd <* USEDIN(SELF,
                                  'INTEGRATED_CNC_SCHEMA.PROPERTY_DEFINITION.DEFINITION') | (
                SIZEOF(QUERY (pdr <* USEDIN(pd, 'INTEGRATED_CNC_SCHEMA.' +
                  'PROPERTY_DEFINITION_REPRESENTATION.DEFINITION') | (
                    'INTEGRATED_CNC_SCHEMA.' +
                    'SHAPE_REPRESENTATION_WITH_PARAMETERS' IN TYPEOF(pdr.
                    used_representation)) AND ((6 <= SIZEOF(pdr.
                    used_representation.items)) AND (SIZEOF(pdr.
                    used_representation.items) <= 9)))) = 1))) = 1;
    WR3: SIZEOF(QUERY (pd <* USEDIN(SELF,
                                  'INTEGRATED_CNC_SCHEMA.PROPERTY_DEFINITION.DEFINITION') | NOT
                (SIZEOF(QUERY (impl_rep <* QUERY (pdr <* USEDIN(pd,
                  'INTEGRATED_CNC_SCHEMA.' +
                  'PROPERTY_DEFINITION_REPRESENTATION.DEFINITION') | (
                    'INTEGRATED_CNC_SCHEMA.' +
                    'SHAPE_REPRESENTATION_WITH_PARAMETERS' IN TYPEOF(pdr.
                    used_representation))) | NOT (SIZEOF(QUERY (it <* impl_rep.
                    used_representation.items | ((
                    'INTEGRATED_CNC_SCHEMA.MEASURE_REPRESENTATION_ITEM' IN TYPEOF
                    (it)) AND ('INTEGRATED_CNC_SCHEMA.COUNT_MEASURE' IN TYPEOF(it
                    \measure_with_unit.value_component))) AND (it.name =
                    'number of teeth')) <= 1))) = 0))) = 0;

```

```

WR4: SIZEOF(QUERY (pd <* USEDIN(SELF,
    'INTEGRATED_CNC_SCHEMA.PROPERTY_DEFINITION.DEFINITION') | NOT
    (SIZEOF(QUERY (impl_rep <* QUERY (pdr <* USEDIN(pd,
    'INTEGRATED_CNC_SCHEMA.' +
    'PROPERTY_DEFINITION_REPRESENTATION.DEFINITION') | (
    'INTEGRATED_CNC_SCHEMA.' +
    'SHAPE_REPRESENTATION_WITH_PARAMETERS' IN TYPEOF(pdr.
    used_representation))) | NOT (SIZEOF(QUERY (it <* impl_rep.
    used_representation.items | (SIZEOF([
    'INTEGRATED_CNC_SCHEMA.MEASURE_REPRESENTATION_ITEM',
    'INTEGRATED_CNC_SCHEMA.LENGTH_MEASURE_WITH_UNIT' ] * TYPEOF(
    it)) = 2) AND (it.name = 'major diameter')) = 1))) = 0))) =
    0;

WR5: SIZEOF(QUERY (pd <* USEDIN(SELF,
    'INTEGRATED_CNC_SCHEMA.PROPERTY_DEFINITION.DEFINITION') | NOT
    (SIZEOF(QUERY (impl_rep <* QUERY (pdr <* USEDIN(pd,
    'INTEGRATED_CNC_SCHEMA.' +
    'PROPERTY_DEFINITION_REPRESENTATION.DEFINITION') | (
    'INTEGRATED_CNC_SCHEMA.' +
    'SHAPE_REPRESENTATION_WITH_PARAMETERS' IN TYPEOF(pdr.
    used_representation))) | NOT (SIZEOF(QUERY (it <* impl_rep.
    used_representation.items | (SIZEOF([
    'INTEGRATED_CNC_SCHEMA.MEASURE_REPRESENTATION_ITEM',
    'INTEGRATED_CNC_SCHEMA.LENGTH_MEASURE_WITH_UNIT' ] * TYPEOF(
    it)) = 2) AND (it.name = 'nominal diameter')) = 1))) = 0)))
    = 0;

WR6: SIZEOF(QUERY (pd <* USEDIN(SELF,
    'INTEGRATED_CNC_SCHEMA.PROPERTY_DEFINITION.' + 'DEFINITION') |
    NOT (SIZEOF(QUERY (impl_rep <* QUERY (pdr <* USEDIN(pd,
    'INTEGRATED_CNC_SCHEMA.' +
    'PROPERTY_DEFINITION_REPRESENTATION.DEFINITION') | (
    'INTEGRATED_CNC_SCHEMA.' +
    'SHAPE_REPRESENTATION_WITH_PARAMETERS' IN TYPEOF(pdr.
    used_representation))) | NOT (SIZEOF(QUERY (it <* impl_rep.
    used_representation.items | (SIZEOF([
    'INTEGRATED_CNC_SCHEMA.MEASURE_REPRESENTATION_ITEM',
    'INTEGRATED_CNC_SCHEMA.LENGTH_MEASURE_WITH_UNIT' ] * TYPEOF(
    it)) = 2) AND (it.name = 'tooth depth')) <= 1))) = 0))) = 0;

WR7: SIZEOF(QUERY (pd <* USEDIN(SELF,
    'INTEGRATED_CNC_SCHEMA.PROPERTY_DEFINITION.DEFINITION') | NOT
    (SIZEOF(QUERY (impl_rep <* QUERY (pdr <* USEDIN(pd,
    'INTEGRATED_CNC_SCHEMA.' +
    'PROPERTY_DEFINITION_REPRESENTATION.DEFINITION') | (
    'INTEGRATED_CNC_SCHEMA.' +
    'SHAPE_REPRESENTATION_WITH_PARAMETERS' IN TYPEOF(pdr.
    used_representation))) | NOT (SIZEOF(QUERY (it <* impl_rep.
    used_representation.items | (SIZEOF([
    'INTEGRATED_CNC_SCHEMA.MEASURE_REPRESENTATION_ITEM',
    'INTEGRATED_CNC_SCHEMA.LENGTH_MEASURE_WITH_UNIT' ] * TYPEOF(
    it)) = 2) AND (it.name = 'root fillet')) <= 1))) = 0))) = 0;

WR8: SIZEOF(QUERY (pd <* USEDIN(SELF,
    'INTEGRATED_CNC_SCHEMA.PROPERTY_DEFINITION.DEFINITION') | NOT
    (SIZEOF(QUERY (impl_rep <* QUERY (pdr <* USEDIN(pd,
    'INTEGRATED_CNC_SCHEMA.' +

```

```

'PROPERTY_DEFINITION_REPRESENTATION.DEFINITION')| (
'INTEGRATED_CNC_SCHEMA.' +
'SHAPE_REPRESENTATION_WITH_PARAMETERS' IN TYPEOF(pdr.
used_representation)))| NOT (SIZEOF(QUERY (it <* impl_rep.
used_representation.items| (SIZEOF([
'INTEGRATED_CNC_SCHEMA.MEASURE_REPRESENTATION_ITEM',
'INTEGRATED_CNC_SCHEMA.LENGTH_MEASURE_WITH_UNIT' ] * TYPEOF(
it)) = 2) AND (it.name = 'diametral pitch')) = 1))) = 0))) =
0;
WR9: NOT (SELF\characterized_object.description IN [ 'diamond',
'diagonal' ]) OR (SIZEOF(QUERY (pd <* USEDIN(SELF,
'INTEGRATED_CNC_SCHEMA.PROPERTY_DEFINITION.DEFINITION')| NOT
(SIZEOF(QUERY (impl_rep <* QUERY (pdr <* USEDIN(pdr,
'INTEGRATED_CNC_SCHEMA.' +
'PROPERTY_DEFINITION_REPRESENTATION.DEFINITION')| (
'INTEGRATED_CNC_SCHEMA.' +
'SHAPE_REPRESENTATION_WITH_PARAMETERS' IN TYPEOF(pdr.
used_representation)))| NOT (SIZEOF(QUERY (it <* impl_rep.
used_representation.items| (SIZEOF([
'INTEGRATED_CNC_SCHEMA.MEASURE_REPRESENTATION_ITEM',
'INTEGRATED_CNC_SCHEMA.PLANE_ANGLE_MEASURE_WITH_UNIT' ] *
TYPEOF(it)) = 2) AND (it.name = 'helix angle')) = 1)))) = 0))
) = 0);
WR10: NOT (SELF\characterized_object.description = 'diagonal') OR (
SIZEOF(QUERY (pd <* USEDIN(SELF,
'INTEGRATED_CNC_SCHEMA.PROPERTY_DEFINITION.DEFINITION')| NOT
(SIZEOF(QUERY (impl_rep <* QUERY (pdr <* USEDIN(pdr,
'INTEGRATED_CNC_SCHEMA.' +
'PROPERTY_DEFINITION_REPRESENTATION.DEFINITION')| (
'INTEGRATED_CNC_SCHEMA.' +
'SHAPE_REPRESENTATION_WITH_PARAMETERS' IN TYPEOF(pdr.
used_representation)))| NOT (SIZEOF(QUERY (it <* impl_rep.
used_representation.items| (
'INTEGRATED_CNC_SCHEMA.DESCRPTIVE_REPRESENTATION_ITEM' IN
TYPEOF(it)) AND (it.name = 'helix hand')) = 1)))) = 0))) = 0)
;
WR11: SIZEOF(QUERY (pds <* QUERY (pd <* USEDIN(SELF,
'INTEGRATED_CNC_SCHEMA.PROPERTY_DEFINITION.DEFINITION')| (
'INTEGRATED_CNC_SCHEMA.PRODUCT_DEFINITION_SHAPE' IN TYPEOF(pd
)))| NOT (SIZEOF(QUERY (sa_occ <* USEDIN(pds,
'INTEGRATED_CNC_SCHEMA.SHAPE_ASPECT.OF_SHAPE')| (sa_occ.
description = 'partial area occurrence') AND (SIZEOF(QUERY (
sdr <* QUERY (sar <* USEDIN(sa_occ,
'INTEGRATED_CNC_SCHEMA.SHAPE_ASPECT_RELATIONSHIP.' +
'RELATED_SHAPE_ASPECT')| (sar.description =
'applied area usage') AND ('INTEGRATED_CNC_SCHEMA.' +
'SHAPE_DEFINING_RELATIONSHIP' IN TYPEOF(sar)))| (
'INTEGRATED_CNC_SCHEMA.APPLIED_AREA' IN TYPEOF(sdr.
relating_shape_aspect)))) = 1))) = 1))) = 0;
WR12: SIZEOF(QUERY (pds <* QUERY (pd <* USEDIN(SELF,
'INTEGRATED_CNC_SCHEMA.PROPERTY_DEFINITION.DEFINITION')| (
'INTEGRATED_CNC_SCHEMA.PRODUCT_DEFINITION_SHAPE' IN TYPEOF(pd
)))| NOT (SIZEOF(QUERY (sa_occ <* USEDIN(pds,
'INTEGRATED_CNC_SCHEMA.SHAPE_ASPECT.OF_SHAPE')| (SIZEOF(QUERY

```

```

        (sdr <* QUERY (sar <* USEDIN(sa_occ,
        'INTEGRATED_CNC_SCHEMA.SHAPE_ASPECT_RELATIONSHIP.' +
        'RELATED_SHAPE_ASPECT')| (sar.description = 'applied shape')
        AND ('INTEGRATED_CNC_SCHEMA.SHAPE_DEFINING_RELATIONSHIP' IN
        TYPEOF(sar)))| ('INTEGRATED_CNC_SCHEMA.SHAPE_ASPECT' IN
        TYPEOF(sdr.relatng_shape_aspect)))) = 1))) = 1))) = 0;
END_ENTITY; -- 10303-522: aic_machining_feature

ENTITY turning_type_operation
  SUBTYPE OF (machining_operation);
  WHERE
  WR1: ((verify_optional_relatng_amr_with_name (SELF, 'approach',
        ['INTEGRATED_CNC_SCHEMA.MACHINING_STRATEGY_RELATIONSHIP'])) AND
        (verify_related_type_for_amr_with_name (SELF, 'approach',
        ['INTEGRATED_CNC_SCHEMA.MACHINING_STRATEGY_RELATIONSHIP'],
        ['INTEGRATED_CNC_SCHEMA.MACHINING_APPROACH_RETRACT_STRATEGY'])))
        );

  WR2: ((verify_optional_relatng_amr_with_name (SELF, 'retract',
        ['INTEGRATED_CNC_SCHEMA.MACHINING_STRATEGY_RELATIONSHIP'])) AND
        (verify_related_type_for_amr_with_name (SELF, 'retract',
        ['INTEGRATED_CNC_SCHEMA.MACHINING_STRATEGY_RELATIONSHIP'],
        ['INTEGRATED_CNC_SCHEMA.MACHINING_APPROACH_RETRACT_STRATEGY'])))
        );

  WR3: ((verify_optional_relatng_amr_with_name (SELF, 'machining',
        ['INTEGRATED_CNC_SCHEMA.MACHINING_STRATEGY_RELATIONSHIP'])) AND
        (verify_related_type_for_amr_with_name (SELF, 'machining',
        ['INTEGRATED_CNC_SCHEMA.MACHINING_STRATEGY_RELATIONSHIP'],
        ['INTEGRATED_CNC_SCHEMA.TURNING_TYPE_STRATEGY'])))
        );

END_ENTITY; -- 10303-238: integrated_cnc_schema

ENTITY turning_type_strategy
  SUBTYPE OF (machining_strategy);
  WHERE
  WR1: (SELF.description IN ['unidirectional', 'bidirectional',
        'contour', 'thread', 'grooving', 'multistep grooving',
        'explicit']);

  WR2: ((verify_optional_action_property (SELF, 'overcut length')) AND
        (verify_length_measure_action_property (SELF, 'overcut length'))
        );

  WR3: ((verify_optional_action_property (SELF, 'multiple passes')) AND
        (verify_enumeration_action_property (SELF, 'multiple passes',
        ['multiple passes allowed', 'multiple passes not allowed'])))
        );

  WR4: ((verify_optional_action_property (SELF, 'cutting depth')) AND
        (0 = SIZEOF (QUERY (prop <*
        get_action_property (SELF, 'cutting depth') | NOT
        (0 < SIZEOF (QUERY (prep <* USEDIN (prop, 'INTEGRATED_CNC_SCHEMA.' +

```

```

'ACTION_PROPERTY_REPRESENTATION.PROPERTY') |
(1 = SIZEOF (QUERY (it <* prep.representation.items |
  (('INTEGRATED_CNC_SCHEMA.COMPOUND_REPRESENTATION_ITEM'
    IN TYPEOF(it)) AND
  ('INTEGRATED_CNC_SCHEMA.LIST_REPRESENTATION_ITEM'
    IN TYPEOF(it.item_element)) AND
  (0 = SIZEOF (QUERY (ie <* it.item_element | NOT (SIZEOF([
    'INTEGRATED_CNC_SCHEMA.MEASURE_REPRESENTATION_ITEM',
    'INTEGRATED_CNC_SCHEMA.LENGTH_MEASURE_WITH_UNIT'] *
    TYPEOF(ie)) = 2))))
  ))))
  )))
  )))
  )))
);

WR5: ((verify_optional_action_property (SELF, 'variable feedrate')) AND
(verify_rep_type_for_action_property (SELF, 'variable feedrate',
  ['INTEGRATED_CNC_SCHEMA.MACHINING_FEED_SPEED_REPRESENTATION'])) AND
(verify_rep_name_for_action_property (SELF, 'variable feedrate',
  ['relative speed']))
);

WR6: NOT (SELF.description = 'unidirectional') OR
((verify_optional_action_property (SELF, 'feed direction')) AND
(verify_rep_item_for_action_property (SELF, 'feed direction',
  ['INTEGRATED_CNC_SCHEMA.DIRECTION'])) AND

(verify_optional_action_property (SELF, 'back path direction')) AND
(verify_rep_item_for_action_property (SELF, 'back path direction',
  ['INTEGRATED_CNC_SCHEMA.DIRECTION'])) AND

(verify_optional_action_property (SELF, 'lift direction')) AND
(verify_rep_item_for_action_property (SELF, 'lift direction',
  ['INTEGRATED_CNC_SCHEMA.DIRECTION'])) AND

(verify_optional_action_property (SELF, 'stepover direction')) AND
(verify_rep_item_for_action_property (SELF, 'stepover direction',
  ['INTEGRATED_CNC_SCHEMA.DIRECTION'])) AND

(verify_optional_action_property (SELF, 'lift height')) AND
(verify_length_measure_action_property (SELF, 'lift height')) AND

(verify_optional_action_property (SELF, 'lift feedrate')) AND
(verify_rep_type_for_action_property (SELF, 'lift feedrate',
  ['INTEGRATED_CNC_SCHEMA.MACHINING_FEED_SPEED_REPRESENTATION'])) AND
(verify_rep_name_for_action_property (SELF, 'lift feedrate',
  ['feed speed', 'feed per revolution'])) AND

(verify_optional_action_property (SELF, 'stepover feedrate')) AND
(verify_rep_type_for_action_property (SELF, 'stepover feedrate',
  ['INTEGRATED_CNC_SCHEMA.MACHINING_FEED_SPEED_REPRESENTATION'])) AND
(verify_rep_name_for_action_property (SELF, 'stepover feedrate',
  ['feed speed', 'feed per revolution']))
);

```

```

WR7: NOT (SELF.description = 'bidirectional') OR
((verify_optional_action_property (SELF, 'feed direction')) AND
(verify_rep_item_for_action_property (SELF, 'feed direction',
['INTEGRATED_CNC_SCHEMA.DIRECTION'])) AND

(verify_optional_action_property (SELF, 'stepover direction')) AND
(verify_rep_item_for_action_property (SELF, 'stepover direction',
['INTEGRATED_CNC_SCHEMA.DIRECTION'])) AND

(verify_optional_action_property (SELF, 'stepover feedrate')) AND
(verify_rep_type_for_action_property (SELF, 'stepover feedrate',
['INTEGRATED_CNC_SCHEMA.MACHINING_FEED_SPEED_REPRESENTATION'])) AND
(verify_rep_name_for_action_property (SELF, 'stepover feedrate',
['feed speed', 'feed per revolution']))
);

```

```

WR8: NOT (SELF.description = 'contour') OR
((verify_optional_action_property (SELF, 'feed direction')) AND
(verify_rep_item_for_action_property (SELF, 'feed direction',
['INTEGRATED_CNC_SCHEMA.DIRECTION'])) AND

(verify_optional_action_property (SELF, 'back path direction')) AND
(verify_rep_item_for_action_property (SELF, 'back path direction',
['INTEGRATED_CNC_SCHEMA.DIRECTION'])) AND

(verify_optional_action_property (SELF, 'lift direction')) AND
(verify_rep_item_for_action_property (SELF, 'lift direction',
['INTEGRATED_CNC_SCHEMA.DIRECTION'])) AND

(verify_optional_action_property (SELF, 'stepover direction')) AND
(verify_rep_item_for_action_property (SELF, 'stepover direction',
['INTEGRATED_CNC_SCHEMA.DIRECTION'])) AND

(verify_optional_action_property (SELF, 'lift height')) AND
(verify_length_measure_action_property (SELF, 'lift height')) AND

(verify_optional_action_property (SELF, 'lift feedrate')) AND
(verify_rep_type_for_action_property (SELF, 'lift feedrate',
['INTEGRATED_CNC_SCHEMA.MACHINING_FEED_SPEED_REPRESENTATION'])) AND
(verify_rep_name_for_action_property (SELF, 'lift feedrate',
['feed speed', 'feed per revolution'])) AND

(verify_optional_action_property (SELF, 'stepover feedrate')) AND
(verify_rep_type_for_action_property (SELF, 'stepover feedrate',
['INTEGRATED_CNC_SCHEMA.MACHINING_FEED_SPEED_REPRESENTATION'])) AND
(verify_rep_name_for_action_property (SELF, 'stepover feedrate',
['feed speed', 'feed per revolution'])) AND

(verify_optional_action_property
(SELF, 'variable stepover feedrate')) AND
(verify_rep_type_for_action_property
(SELF, 'variable stepover feedrate',
['INTEGRATED_CNC_SCHEMA.MACHINING_FEED_SPEED_REPRESENTATION'])) AND

```



```

    (verify_rep_name_for_action_property
      (SELF, 'variable stepover feedrate', ['relative speed']))
  );

WR9: NOT (SELF.description = 'thread') OR
  ((verify_required_action_property      (SELF, 'cut in amount')) AND
   (verify_enumeration_action_property  (SELF, 'cut in amount',
     ['constant depth', 'variable depth', 'constant removal amount'])) AND

   (verify_required_action_property      (SELF, 'threading direction')) AND
   (verify_enumeration_action_property  (SELF, 'threading direction',
     ['left', 'right', 'center', 'left zigzag', 'right zigzag'])) AND

   (verify_optional_action_property      (SELF, 'path return angle')) AND
   (verify_angle_measure_action_property  (SELF, 'path return angle')) AND

   (verify_optional_action_property      (SELF, 'lift height')) AND
   (verify_length_measure_action_property (SELF, 'lift height'))
  );

WR10: NOT (SELF.description IN ['grooving', 'multistep grooving']) OR
  ((verify_optional_action_property      (SELF, 'grooving direction')) AND
   (verify_rep_item_for_action_property  (SELF, 'grooving direction',
     ['INTEGRATED_CNC_SCHEMA.DIRECTION'])) AND

   (verify_optional_action_property      (SELF, 'travel distance')) AND
   (verify_length_measure_action_property (SELF, 'travel distance'))
  );

WR11: NOT (SELF.description = 'multistep grooving') OR
  ((verify_optional_action_property      (SELF, 'retract distance')) AND
   (verify_length_measure_action_property (SELF, 'retract distance'))
  );

END_ENTITY; -- 10303-238: integrated_cnc_schema

ENTITY type_qualifier;
  name : label;
END_ENTITY; -- 10303-45: qualified_measure_schema

ENTITY unary_boolean_expression
  ABSTRACT SUPERTYPE OF (not_expression)
  SUBTYPE OF (boolean_expression, unary_generic_expression);
END_ENTITY; -- 13584-20: iso13584_expressions_schema

ENTITY unary_generic_expression
  ABSTRACT SUPERTYPE
  SUBTYPE OF (generic_expression);
  operand : generic_expression;
END_ENTITY; -- 13584-20: iso13584_generic_expressions_schema

ENTITY uncertainty_measure_with_unit
  SUBTYPE OF (measure_with_unit);
  name      : label;
  description : OPTIONAL text;

```

```

WHERE
  WR1: valid_measure_value(SELf\measure_with_unit.value_component);
END_ENTITY; -- 10303-43: representation_schema

ENTITY uncertainty_qualifier
  SUPERTYPE OF (ONEOF(standard_uncertainty, qualitative_uncertainty));
  measure_name : label;
  description : text;
END_ENTITY; -- 10303-45: qualified_measure_schema

ENTITY uniform_curve
  SUBTYPE OF (b_spline_curve);
END_ENTITY; -- 10303-42: geometry_schema

ENTITY uniform_surface
  SUBTYPE OF (b_spline_surface);
END_ENTITY; -- 10303-42: geometry_schema

ENTITY value_range
  SUBTYPE OF (compound_representation_item);
END_ENTITY; -- 10303-238: integrated_cnc_schema

ENTITY value_representation_item
  SUBTYPE OF (representation_item);
  value_component : measure_value;
  WHERE
    WR1: SIZEOF(QUERY (rep <* using_representations(SELf)| NOT (
      'INTEGRATED_CNC_SCHEMA.GLOBAL_UNIT_ASSIGNED_CONTEXT' IN
      TYPEOF(rep.context_of_items)))) = 0;
END_ENTITY; -- 10303-43: representation_schema

ENTITY variable
  ABSTRACT SUPERTYPE OF (numeric_variable)
  SUBTYPE OF (generic_variable);
END_ENTITY; -- 13584-20: iso13584_expressions_schema

ENTITY variable_semantics
  ABSTRACT SUPERTYPE;
END_ENTITY; -- 13584-20: iso13584_generic_expressions_schema

ENTITY vector
  SUBTYPE OF (geometric_representation_item);
  orientation : direction;
  magnitude : length_measure;
  WHERE
    WR1: magnitude >= 0.0;
END_ENTITY; -- 10303-42: geometry_schema

ENTITY vee_profile
  SUBTYPE OF (shape_aspect);
  WHERE
    WR1: 'INTEGRATED_CNC_SCHEMA.FEATURE_COMPONENT_DEFINITION' IN TYPEOF(
      SELf.of_shape.definition);
    WR2: SIZEOF(QUERY (pd <* USEDIN(SELf,

```

```

'INTEGRATED_CNC_SCHEMA.PROPERTY_DEFINITION.DEFINITION')| NOT
(SIZEOF(QUERY (pdr <* USEDIN(pd, 'INTEGRATED_CNC_SCHEMA.' +
'PROPERTY_DEFINITION_REPRESENTATION.DEFINITION')| (
'INTEGRATED_CNC_SCHEMA.' +
'SHAPE_REPRESENTATION_WITH_PARAMETERS' IN TYPEOF(pdr.
used_representation)))) = 1))) = 0;
WR3: SIZEOF(QUERY (pd <* USEDIN(SELF,
'INTEGRATED_CNC_SCHEMA.PROPERTY_DEFINITION.DEFINITION')| NOT
(SIZEOF(QUERY (impl_rep <* QUERY (pdr <* USEDIN(pd,
'INTEGRATED_CNC_SCHEMA.' +
'PROPERTY_DEFINITION_REPRESENTATION.DEFINITION')| (
'INTEGRATED_CNC_SCHEMA.' +
'SHAPE_REPRESENTATION_WITH_PARAMETERS' IN TYPEOF(pdr.
used_representation)))| NOT (SIZEOF(impl_rep.
used_representation.items) >= 3) AND (SIZEOF(impl_rep.
used_representation.items) <= 6))) = 0))) = 0;
WR4: SIZEOF(QUERY (pd <* USEDIN(SELF,
'INTEGRATED_CNC_SCHEMA.PROPERTY_DEFINITION.DEFINITION')| (
SIZEOF(QUERY (pdr <* USEDIN(pd, 'INTEGRATED_CNC_SCHEMA.' +
'PROPERTY_DEFINITION_REPRESENTATION.DEFINITION')| (
'INTEGRATED_CNC_SCHEMA.' +
'SHAPE_REPRESENTATION_WITH_PARAMETERS' IN TYPEOF(pdr.
used_representation)) AND (SIZEOF(QUERY (srwp_i <* pdr.
used_representation.items| (((srwp_i.name = 'orientation')
OR (srwp_i.name = 'profile angle')) OR (srwp_i.name =
'tilt angle')) OR (srwp_i.name = 'profile radius')) OR (
srwp_i.name = 'first length')) OR (srwp_i.name =
'second length')))) = SIZEOF(pdr.used_representation.items))))
= 1))) = 1;
WR5: SIZEOF(QUERY (pd <* USEDIN(SELF,
'INTEGRATED_CNC_SCHEMA.PROPERTY_DEFINITION.DEFINITION')| NOT
(SIZEOF(QUERY (impl_rep <* QUERY (pdr <* USEDIN(pd,
'INTEGRATED_CNC_SCHEMA.' +
'PROPERTY_DEFINITION_REPRESENTATION.DEFINITION')| (
'INTEGRATED_CNC_SCHEMA.' +
'SHAPE_REPRESENTATION_WITH_PARAMETERS' IN TYPEOF(pdr.
used_representation)))| NOT (SIZEOF(QUERY (it <* impl_rep.
used_representation.items| ('INTEGRATED_CNC_SCHEMA.PLACEMENT'
IN TYPEOF(it)) AND (it.name = 'orientation')) = 1))) = 0)))
= 0;
WR6: SIZEOF(QUERY (pd <* USEDIN(SELF,
'INTEGRATED_CNC_SCHEMA.PROPERTY_DEFINITION.DEFINITION')| NOT
(SIZEOF(QUERY (impl_rep <* QUERY (pdr <* USEDIN(pd,
'INTEGRATED_CNC_SCHEMA.' +
'PROPERTY_DEFINITION_REPRESENTATION.DEFINITION')| (
'INTEGRATED_CNC_SCHEMA.' +
'SHAPE_REPRESENTATION_WITH_PARAMETERS' IN TYPEOF(pdr.
used_representation)))| NOT (SIZEOF(QUERY (it <* impl_rep.
used_representation.items| ((
'INTEGRATED_CNC_SCHEMA.MEASURE_REPRESENTATION_ITEM' IN TYPEOF
(it)) AND ('INTEGRATED_CNC_SCHEMA.LENGTH_MEASURE_WITH_UNIT'
IN TYPEOF(it\measure_with_unit.value_component))) AND (it.
name = 'profile radius')) <= 1))) = 0))) = 0;
WR7: SIZEOF(QUERY (pd <* USEDIN(SELF,

```

```

'INTEGRATED_CNC_SCHEMA.PROPERTY_DEFINITION.DEFINITION')| NOT
(SIZEOF(QUERY (impl_rep <* QUERY (pdr <* USEDIN(pd,
'INTEGRATED_CNC_SCHEMA.' +
'PROPERTY_DEFINITION_REPRESENTATION.DEFINITION')| (
'INTEGRATED_CNC_SCHEMA.' +
'SHAPE_REPRESENTATION_WITH_PARAMETERS' IN TYPEOF(pdr.
used_representation)))| NOT (SIZEOF(QUERY (it <* impl_rep.
used_representation.items| (SIZEOF([
'INTEGRATED_CNC_SCHEMA.MEASURE_REPRESENTATION_ITEM',
'INTEGRATED_CNC_SCHEMA.PLANE_ANGLE_MEASURE_WITH_UNIT' ] *
TYPEOF(it)) = 2) AND (it.name = 'profile angle')) = 1))) = 0
))) = 0;
WR8: SIZEOF(QUERY (pd <* USEDIN(SELF,
'INTEGRATED_CNC_SCHEMA.PROPERTY_DEFINITION.DEFINITION')| NOT
(SIZEOF(QUERY (impl_rep <* QUERY (pdr <* USEDIN(pd,
'INTEGRATED_CNC_SCHEMA.' +
'PROPERTY_DEFINITION_REPRESENTATION.DEFINITION')| (
'INTEGRATED_CNC_SCHEMA.' +
'SHAPE_REPRESENTATION_WITH_PARAMETERS' IN TYPEOF(pdr.
used_representation)))| NOT (SIZEOF(QUERY (it <* impl_rep.
used_representation.items| (SIZEOF([
'INTEGRATED_CNC_SCHEMA.MEASURE_REPRESENTATION_ITEM',
'INTEGRATED_CNC_SCHEMA.PLANE_ANGLE_MEASURE_WITH_UNIT' ] *
TYPEOF(it)) = 2) AND (it.name = 'tilt angle')) = 1))) = 0)))
= 0;
WR9: SIZEOF(QUERY (pd <* USEDIN(SELF,
'INTEGRATED_CNC_SCHEMA.PROPERTY_DEFINITION.DEFINITION')| NOT
(SIZEOF(QUERY (pdr <* USEDIN(pd, 'INTEGRATED_CNC_SCHEMA.' +
'PROPERTY_DEFINITION_REPRESENTATION.DEFINITION')| (
'INTEGRATED_CNC_SCHEMA.PLANAR_SHAPE_REPRESENTATION' IN TYPEOF
(pdr.used_representation)) AND (pdr.used_representation.name
= 'profile limit')) <= 1))) = 0;
WR10: SIZEOF(QUERY (pd <* USEDIN(SELF,
'INTEGRATED_CNC_SCHEMA.PROPERTY_DEFINITION.DEFINITION')| NOT
(SIZEOF(QUERY (impl_rep <* QUERY (pdr <* USEDIN(pd,
'INTEGRATED_CNC_SCHEMA.' +
'PROPERTY_DEFINITION_REPRESENTATION.DEFINITION')| (
'INTEGRATED_CNC_SCHEMA.' +
'SHAPE_REPRESENTATION_WITH_PARAMETERS' IN TYPEOF(pdr.
used_representation)))| NOT (SIZEOF(QUERY (it <* impl_rep.
used_representation.items| ((
'INTEGRATED_CNC_SCHEMA.MEASURE_REPRESENTATION_ITEM' IN TYPEOF
(it)) AND ('INTEGRATED_CNC_SCHEMA.LENGTH_MEASURE_WITH_UNIT'
IN TYPEOF(it\measure_with_unit.value_component)) AND (it.
name = 'first length')) <= 1))) = 0))) = 0;
WR11: SIZEOF(QUERY (pd <* USEDIN(SELF,
'INTEGRATED_CNC_SCHEMA.PROPERTY_DEFINITION.DEFINITION')| NOT
(SIZEOF(QUERY (impl_rep <* QUERY (pdr <* USEDIN(pd,
'INTEGRATED_CNC_SCHEMA.' +
'PROPERTY_DEFINITION_REPRESENTATION.DEFINITION')| (
'INTEGRATED_CNC_SCHEMA.' +
'SHAPE_REPRESENTATION_WITH_PARAMETERS' IN TYPEOF(pdr.
used_representation)))| NOT (SIZEOF(QUERY (it <* impl_rep.
used_representation.items| ((

```

```

        'INTEGRATED_CNC_SCHEMA.MEASURE_REPRESENTATION_ITEM' IN TYPEOF
        (it)) AND ('INTEGRATED_CNC_SCHEMA.LENGTH_MEASURE_WITH_UNIT'
        IN TYPEOF(it\measure_with_unit.value_component))) AND (it.
        name = 'second length')) (<= 1))) = 0))) = 0;
END_ENTITY; -- 10303-522: aic_machining_feature

ENTITY vertex
  SUBTYPE OF (topological_representation_item);
END_ENTITY; -- 10303-42: topology_schema

ENTITY vertex_loop
  SUBTYPE OF (loop);
  loop_vertex : vertex;
END_ENTITY; -- 10303-42: topology_schema

ENTITY vertex_point
  SUBTYPE OF (vertex, geometric_representation_item);
  vertex_geometry : point;
END_ENTITY; -- 10303-42: topology_schema

ENTITY vertex_shell
  SUBTYPE OF (topological_representation_item);
  vertex_shell_extent : vertex_loop;
END_ENTITY; -- 10303-42: topology_schema

ENTITY week_of_year_and_day_date
  SUBTYPE OF (date);
  week_component : week_in_year_number;
  day_component : OPTIONAL day_in_week_number;
END_ENTITY; -- 10303-41: date_time_schema

ENTITY wire_shell
  SUBTYPE OF (topological_representation_item);
  wire_shell_extent : SET [1:?] OF loop;
  WHERE
    WR1: NOT mixed_loop_type_set(wire_shell_extent);
END_ENTITY; -- 10303-42: topology_schema

ENTITY xor_expression
  SUBTYPE OF (binary_boolean_expression);
  SELF\binary_generic_expression.operands : LIST [2:2] OF
    boolean_expression;
END_ENTITY; -- 13584-20: iso13584_expressions_schema

RULE application_context_requires_ap_definition FOR
  (application_context,
  application_protocol_definition);
WHERE
  WR1: (0 = SIZEOF (QUERY (ac <* application_context | NOT
    (1 = SIZEOF (QUERY (apd <* application_protocol_definition |
    (apd.application :=: ac) AND
    (apd.application_interpreted_model_schema_name =
    'integrated_cnc_schema'))))
    ));

```

ISO 10303-238:2007(E)

```

END_RULE; -- 10303-238: integrated_cnc_schema

RULE approval_requires_approval_person_organization FOR
  (approval,
   approval_person_organization);
WHERE
  WR1: (0 = SIZEOF (QUERY (app <* approval | NOT
    (1 <= SIZEOF (QUERY (apo <* approval_person_organization |
      (app :=: apo.authorized_approval))))
    )));
END_RULE; -- 10303-238: integrated_cnc_schema

RULE approval_requires_assignment FOR
  (approval,
   approval_assignment);
WHERE
  WR1: (0 = SIZEOF (QUERY (app <* approval | NOT
    (1 <= SIZEOF (QUERY (aa <* approval_assignment |
      (app :=: aa.assigned_approval))))
    )));
END_RULE; -- 10303-238: integrated_cnc_schema

RULE chamfer_requires_faces_or_features FOR
  (chamfer,
   property_definition_representation,
   feature_component_relationship);
WHERE
  WR1: (0 = SIZEOF (QUERY (cf <* chamfer | NOT (

-- chamfer relates two sets of faces in AP-224 style
((1 = SIZEOF (QUERY (pdr <* property_definition_representation |
  ((pdr.used_representation.name = 'chamfer face') AND
  (pdr.definition.definition :=: cf) AND
  ('INTEGRATED_CNC_SCHEMA.FACE_SHAPE_REPRESENTATION'
   IN TYPEOF (pdr.used_representation)))))) AND

(1 = SIZEOF (QUERY (fcr <* feature_component_relationship |
  ((fcr.relater_shape_aspect :=: cf) AND
  (fcr.related_shape_aspect.description = 'first offset') AND
  ('INTEGRATED_CNC_SCHEMA.CHAMFER_OFFSET'
   IN TYPEOF (fcr.related_shape_aspect)) AND
  ((1 = SIZEOF (QUERY (pdr <* property_definition_representation |
    ((pdr.used_representation.name = 'first face shape') AND
    (pdr.definition.definition :=: fcr.related_shape_aspect) AND
    ('INTEGRATED_CNC_SCHEMA.FACE_SHAPE_REPRESENTATION'
     IN TYPEOF (pdr.used_representation)))
    ))))))) AND

(1 = SIZEOF (QUERY (fcr <* feature_component_relationship |
  ((fcr.relater_shape_aspect :=: cf) AND
  (fcr.related_shape_aspect.description = 'second offset') AND
  ('INTEGRATED_CNC_SCHEMA.CHAMFER_OFFSET'
   IN TYPEOF (fcr.related_shape_aspect)) AND
  ((1 = SIZEOF (QUERY (pdr <* property_definition_representation |

```

```

        ((pdr.used_representation.name = 'second face shape') AND
         (pdr.definition.definition ::= fcr.related_shape_aspect) AND
         ('INTEGRATED_CNC_SCHEMA.FACE_SHAPE_REPRESENTATION'
          IN TYPEOF (pdr.used_representation)))
      )))) ))))
    )
  OR
  -- chamfer relates two features in ISO 14649 style
  ((1 = SIZEOF (QUERY (fcr <* feature_component_relationship |
    ((fcr.name = 'first feature') AND
     (fcr.relating_shape_aspect.of_shape.definition ::= cf) AND
     ('INTEGRATED_CNC_SCHEMA.COMPOSITE_SHAPE_ASPECT'
      IN TYPEOF (fcr.relating_shape_aspect)))))) AND

   (1 = SIZEOF (QUERY (fcr <* feature_component_relationship |
    ((fcr.name = 'second feature') AND
     (fcr.relating_shape_aspect.of_shape.definition ::= cf) AND
     ('INTEGRATED_CNC_SCHEMA.COMPOSITE_SHAPE_ASPECT'
      IN TYPEOF (fcr.relating_shape_aspect))))))
  ))));
END_RULE; -- 10303-238: integrated_cnc_schema

RULE compatible_dimension FOR
  (cartesian_point,
   direction,
   representation_context,
   geometric_representation_context);
WHERE
  WR1: SIZEOF(QUERY (x <* cartesian_point| (SIZEOF(QUERY (y <*
    geometric_representation_context| item_in_context(x, y) AND (
    HIINDEX(x.coordinates) <> y.coordinate_space_dimension))) > 0
  ))) = 0;
  WR2: SIZEOF(QUERY (x <* direction| (SIZEOF(QUERY (y <*
    geometric_representation_context| item_in_context(x, y) AND (
    HIINDEX(x.direction_ratios) <> y.coordinate_space_dimension)
  ) > 0))) = 0;
END_RULE; -- 10303-42: geometry_schema

RULE dependent_instantiable_approval_status FOR
  (approval_status);
WHERE
  WR1: (0 = SIZEOF (QUERY (ast <* approval_status | NOT
    (1 <= SIZEOF (USEDIN (ast, '')))
  )));
END_RULE; -- 10303-238: integrated_cnc_schema

RULE dependent_instantiable_derived_unit FOR
  (derived_unit);
WHERE
  WR1: (0 = SIZEOF (QUERY (du <* derived_unit | NOT
    (1 <= SIZEOF (USEDIN (du, '')))
  )));
END_RULE; -- 10303-238: integrated_cnc_schema

```

## ISO 10303-238:2007(E)

```

RULE dependent_instantiable_named_unit FOR
  (named_unit);
WHERE
  WR1:  (0 = SIZEOF (QUERY (nu <* named_unit | NOT
    (1 <= SIZEOF (USEDIN (nu, ''))
    ))));
END_RULE; -- 10303-238: integrated_cnc_schema

RULE edge_round_requires_faces_or_features FOR
  (edge_round,
  property_definition_representation,
  feature_component_relationship);
WHERE
  WR1:  (0 = SIZEOF (QUERY (er <* edge_round | NOT (

-- edge round relates two sets of faces in AP-224 style
((1 = SIZEOF (QUERY (pdr <* property_definition_representation |
  ((pdr.used_representation.name = 'edge round face') AND
  (pdr.definition.definition ::= er) AND
  ('INTEGRATED_CNC_SCHEMA.FACE_SHAPE_REPRESENTATION'
  IN TYPEOF (pdr.used_representation)))))) AND

  (1 = SIZEOF (QUERY (pdr <* property_definition_representation |
  ((pdr.used_representation.name = 'first face shape') AND
  (pdr.definition.definition ::= er) AND
  ('INTEGRATED_CNC_SCHEMA.FACE_SHAPE_REPRESENTATION'
  IN TYPEOF (pdr.used_representation)))))) AND

  (1 = SIZEOF (QUERY (pdr <* property_definition_representation |
  ((pdr.used_representation.name = 'second face shape') AND
  (pdr.definition.definition ::= er) AND
  ('INTEGRATED_CNC_SCHEMA.FACE_SHAPE_REPRESENTATION'
  IN TYPEOF (pdr.used_representation))))))
  )
OR
-- edge round relates two features in ISO 14649 style
((1 = SIZEOF (QUERY (fcr <* feature_component_relationship |
  ((fcr.name = 'first feature') AND
  (fcr.relating_shape_aspect.of_shape.definition ::= er) AND
  ('INTEGRATED_CNC_SCHEMA.COMPOSITE_SHAPE_ASPECT'
  IN TYPEOF (fcr.relating_shape_aspect)))))) AND

  (1 = SIZEOF (QUERY (fcr <* feature_component_relationship |
  ((fcr.name = 'second feature') AND
  (fcr.relating_shape_aspect.of_shape.definition ::= er) AND
  ('INTEGRATED_CNC_SCHEMA.COMPOSITE_SHAPE_ASPECT'
  IN TYPEOF (fcr.relating_shape_aspect))))))
  ))));
END_RULE; -- 10303-238: integrated_cnc_schema

RULE feature_optional_machining_property_process FOR
  (shape_aspect,
  process_property_association);
WHERE

```



```

WR1: (0 = SIZEOF (QUERY (sa <* shape_aspect |
('INTEGRATED_CNC_SCHEMA.FEATURE_DEFINITION' IN TYPEOF (sa)) OR
('INTEGRATED_CNC_SCHEMA.TRANSITION_FEATURE' IN TYPEOF (sa)))
AND NOT
(1 >= SIZEOF (QUERY (ppa <* process_property_association |
((ppa.property_or_shape ==: sa) AND
(ppa.process.name = 'machining')))))
));
END_RULE; -- 10303-238: integrated_cnc_schema

RULE nc_variable_compatible_initial_value FOR
(expression_representation_item,
representation_item_relationship);
WHERE
-- each nc_variable has at most one one initial value
WR1: (0 = SIZEOF (QUERY (nv <* expression_representation_item |
('INTEGRATED_CNC_SCHEMA.NUMERIC_VARIABLE'
IN TYPEOF (nv)) AND NOT
(1 >= SIZEOF (QUERY (rir <* representation_item_relationship |
(rir.description = 'initial value') AND
(rir.relating_representation_item ==: nv)
))))));

-- the types on either side of the initial value relationship must match
-- each nc_variable has at most one one initial value
WR2: (0 = SIZEOF (QUERY (rir <* representation_item_relationship |
(rir.description = 'initial value') AND
('INTEGRATED_CNC_SCHEMA.NUMERIC_VARIABLE'
IN TYPEOF (rir.relating_representation_item))
AND NOT
(((('INTEGRATED_CNC_SCHEMA.INT_NUMERIC_VARIABLE'
IN TYPEOF (rir.relating_representation_item)) AND
('INTEGRATED_CNC_SCHEMA.INT_LITERAL'
IN TYPEOF (rir.related_representation_item)))
OR
(((('INTEGRATED_CNC_SCHEMA.REAL_NUMERIC_VARIABLE'
IN TYPEOF (rir.relating_representation_item)) AND
('INTEGRATED_CNC_SCHEMA.REAL_LITERAL'
IN TYPEOF (rir.related_representation_item)
))))));
END_RULE; -- 10303-238: integrated_cnc_schema

RULE product_requires_version FOR
(product,
product_definition_formation);
WHERE
WR1: (0 = SIZEOF (QUERY (prod <* product | NOT
(1 <= SIZEOF (QUERY (pdf <* product_definition_formation |
(prod ==: pdf.of_product))))
));
END_RULE; -- 10303-238: integrated_cnc_schema

RULE restrict_unneeded_feature_usage FOR (feature_definition);
WHERE

```

```

WR1:  (0 = SIZEOF (QUERY (fd <* feature_definition |
    ('INTEGRATED_CNC_SCHEMA.FILLET' IN TYPEOF(fd)) OR
    ('INTEGRATED_CNC_SCHEMA.GEAR' IN TYPEOF(fd)) OR
    ('INTEGRATED_CNC_SCHEMA.MARKING' IN TYPEOF(fd)) OR
    ('INTEGRATED_CNC_SCHEMA.PROTRUSION' IN TYPEOF(fd)) OR
    ('INTEGRATED_CNC_SCHEMA.RIB_TOP' IN TYPEOF(fd))
    )));
END_RULE; -- 10303-238: integrated_cnc_schema

RULE security_classification_requires_assignment FOR
    (security_classification,
    security_classification_assignment);
WHERE
    WR1:  (0 = SIZEOF (QUERY (sc <* security_classification | NOT
        (1 <= SIZEOF (QUERY (sca <* security_classification_assignment |
            (sc ::= sca.assigned_security_classification))))
        )));
END_RULE; -- 10303-238: integrated_cnc_schema

FUNCTION acyclic (
    arg1 : generic_expression;
    arg2 : SET OF generic_expression
) : BOOLEAN;
LOCAL
    result : BOOLEAN;
END_LOCAL;
IF 'INTEGRATED_CNC_SCHEMA.SIMPLE_GENERIC_EXPRESSION' IN TYPEOF(arg1)
    THEN
        RETURN (TRUE);
    END_IF;
IF arg1 IN arg2 THEN
    RETURN (FALSE);
    END_IF;
IF 'INTEGRATED_CNC_SCHEMA.UNARY_GENERIC_EXPRESSION' IN TYPEOF(arg1)
    THEN
        RETURN (acyclic(arg1\unary_generic_expression.operand, arg2 + [ arg1
            ]));
    END_IF;
IF 'INTEGRATED_CNC_SCHEMA.BINARY_GENERIC_EXPRESSION' IN TYPEOF(arg1)
    THEN
        RETURN (acyclic(arg1\binary_generic_expression.operands[1], (arg2 + [
            arg1 ])) AND acyclic(arg1\binary_generic_expression.operands[2], (
            arg2 + [ arg1 ])));
    END_IF;
IF 'INTEGRATED_CNC_SCHEMA.MULTIPLE_ARITY_GENERIC_EXPRESSION' IN TYPEOF(
    arg1) THEN
    result := TRUE;
    REPEAT i := 1 TO SIZEOF(arg1\multiple_arity_generic_expression.
        operands);
        result := result AND acyclic(arg1\multiple_arity_generic_expression
            .operands[i], (arg2 + [ arg1 ]));
    END_REPEAT;
    RETURN (result);
    END_IF;

```

```

END_FUNCTION; -- 13584-20: iso13584_generic_expressions_schema

FUNCTION acyclic_curve_replica (
  rep      : curve_replica;
  parent   : curve
) : BOOLEAN;
IF NOT ('INTEGRATED_CNC_SCHEMA.CURVE_REPLICA' IN TYPEOF(parent)) THEN
  RETURN (TRUE);
END_IF;
IF parent :=: rep THEN
  RETURN (FALSE);
ELSE
  RETURN (acyclic_curve_replica(rep, parent\curve_replica.parent_curve)
);
END_IF;
END_FUNCTION; -- 10303-42: geometry_schema

```

```

FUNCTION acyclic_mapped_representation (
  parent_set   : SET OF representation;
  children_set : SET OF representation_item
) : BOOLEAN;
LOCAL
  x : SET OF representation_item;
  y : SET OF representation_item;
END_LOCAL;
x := QUERY (z <* children_set | 'INTEGRATED_CNC_SCHEMA.MAPPED_ITEM' IN
  TYPEOF(z));
IF SIZEOF(x) > 0 THEN
  REPEAT i := 1 TO HIINDEX(x);
    IF x[i]\mapped_item.mapping_source.mapped_representation IN
      parent_set THEN
      RETURN (FALSE);
    END_IF;
    IF NOT acyclic_mapped_representation((parent_set + x[i]\mapped_item
      .mapping_source.mapped_representation), x[i]\mapped_item.
      mapping_source.mapped_representation.items) THEN
      RETURN (FALSE);
    END_IF;
  END_REPEAT;
END_IF;
x := children_set - x;
IF SIZEOF(x) > 0 THEN
  REPEAT i := 1 TO HIINDEX(x);
    y := QUERY (z <* bag_to_set(USEDIN(x[i], '')) |
      'INTEGRATED_CNC_SCHEMA.REPRESENTATION_ITEM' IN TYPEOF(z));
    IF NOT acyclic_mapped_representation(parent_set, y) THEN
      RETURN (FALSE);
    END_IF;
  END_REPEAT;
END_IF;
RETURN (TRUE);
END_FUNCTION; -- 10303-43: representation_schema

```

```

FUNCTION acyclic_point_replica (

```

```

    rep      : point_replica;
    parent   : point
  ) : BOOLEAN;
  IF NOT ('INTEGRATED_CNC_SCHEMA.POINT_REPLICA' IN TYPEOF(parent)) THEN
    RETURN (TRUE);
  END_IF;
  IF parent ==: rep THEN
    RETURN (FALSE);
  ELSE
    RETURN (acyclic_point_replica(rep, parent\point_replica.parent_pt));
  END_IF;
END_FUNCTION; -- 10303-42: geometry_schema

```

```

FUNCTION acyclic_product_category_relationship (
  relation : product_category_relationship;
  children : SET OF product_category
) : BOOLEAN;
LOCAL
  x : SET OF product_category_relationship;
  local_children : SET OF product_category;
END_LOCAL;
REPEAT i := 1 TO HIINDEX(children);
  IF relation.category ==: children[i] THEN
    RETURN (FALSE);
  END_IF;
END_REPEAT;
x := bag_to_set(USEDIN(relation.category, 'INTEGRATED_CNC_SCHEMA.' +
  'PRODUCT_CATEGORY_RELATIONSHIP.SUB_CATEGORY'));
local_children := children + relation.category;
IF SIZEOF(x) > 0 THEN
  REPEAT i := 1 TO HIINDEX(x);
    IF NOT acyclic_product_category_relationship(x[i], local_children)
      THEN
        RETURN (FALSE);
      END_IF;
  END_REPEAT;
END_IF;
RETURN (TRUE);
END_FUNCTION; -- 10303-41: product_definition_schema

```

```

FUNCTION acyclic_product_definition_relationship (
  relation          : product_definition_relationship;
  relatives         : SET [1:?] OF product_definition;
  specific_relation : STRING
) : BOOLEAN;
LOCAL
  x : SET OF product_definition_relationship;
END_LOCAL;
IF relation.relativing_product_definition IN relatives THEN
  RETURN (FALSE);
END_IF;
x := QUERY (pd <* bag_to_set(USEDIN(relation.
  relating_product_definition, 'INTEGRATED_CNC_SCHEMA.' +
  'PRODUCT_DEFINITION_RELATIONSHIP.' + 'RELATED_PRODUCT_DEFINITION')) |

```

```

    specific_relation IN TYPEOF(pd));
REPEAT i := 1 TO HIINDEX(x);
    IF NOT acyclic_product_definition_relationship(x[i], (relatives +
        relation.relativing_product_definition), specific_relation) THEN
        RETURN (FALSE);
    END_IF;
END_REPEAT;
RETURN (TRUE);
END_FUNCTION; -- 10303-41: product_definition_schema

FUNCTION acyclic_surface_replica (
    rep      : surface_replica;
    parent   : surface
) : BOOLEAN;
IF NOT ('INTEGRATED_CNC_SCHEMA.SURFACE_REPLICA' IN TYPEOF(parent)) THEN
    RETURN (TRUE);
END_IF;
IF parent :=: rep THEN
    RETURN (FALSE);
ELSE
    RETURN (acyclic_surface_replica(rep, parent\surface_replica.
        parent_surface));
END_IF;
END_FUNCTION; -- 10303-42: geometry_schema

FUNCTION associated_surface (
    arg : pcurve_or_surface
) : surface;
LOCAL
    surf : surface;
END_LOCAL;
IF 'INTEGRATED_CNC_SCHEMA.PCURVE' IN TYPEOF(arg) THEN
    surf := arg.basis_surface;
ELSE
    surf := arg;
END_IF;
RETURN (surf);
END_FUNCTION; -- 10303-42: geometry_schema

FUNCTION bag_to_set (
    the_bag : BAG OF GENERIC : intype
) : SET OF GENERIC : intype;
LOCAL
    the_set : SET OF GENERIC : intype := [];
END_LOCAL;
IF SIZEOF(the_bag) > 0 THEN
    REPEAT i := 1 TO HIINDEX(the_bag);
        the_set := the_set + the_bag[i];
    END_REPEAT;
END_IF;
RETURN (the_set);
END_FUNCTION; -- 10303-41: support_resource_schema

FUNCTION base_axis (

```

ISO 10303-238:2007(E)

```

dim      : INTEGER;
axis1   : direction;
axis2   : direction;
axis3   : direction
) : LIST [2:3] OF direction;
LOCAL
u : LIST [2:3] OF direction;
factor : REAL;
d1 : direction;
d2 : direction;
END_LOCAL;
IF dim = 3 THEN
    d1 := NVL(normalise(axis3), dummy_gri || direction([ 0.0, 0.0, 1.0 ]))
    );
    d2 := first_proj_axis(d1, axis1);
    u := [ d2, second_proj_axis(d1, d2, axis2), d1 ];
ELSE
    IF EXISTS(axis1) THEN
        d1 := normalise(axis1);
        u := [ d1, orthogonal_complement(d1) ];
        IF EXISTS(axis2) THEN
            factor := dot_product(axis2, u[2]);
            IF factor < 0.0 THEN
                u[2].direction_ratios[1] := -u[2].direction_ratios[1];
                u[2].direction_ratios[2] := -u[2].direction_ratios[2];
            END_IF;
        END_IF;
    ELSE
        IF EXISTS(axis2) THEN
            d1 := normalise(axis2);
            u := [ orthogonal_complement(d1), d1 ];
            u[1].direction_ratios[1] := -u[1].direction_ratios[1];
            u[1].direction_ratios[2] := -u[1].direction_ratios[2];
        ELSE
            u := [ dummy_gri || direction([ 1.0, 0.0 ]), dummy_gri ||
                direction([ 0.0, 1.0 ]) ];
        END_IF;
    END_IF;
END_IF;
RETURN (u);
END_FUNCTION; -- 10303-42: geometry_schema

FUNCTION boolean_choose (
b      : BOOLEAN;
choice1 : GENERIC : item;
choice2 : GENERIC : item
) : GENERIC : item;
IF b THEN
    RETURN (choice1);
ELSE
    RETURN (choice2);
END_IF;
END_FUNCTION; -- 10303-42: topology_schema

```

```

FUNCTION build_2axes (
  ref_direction : direction
) : LIST [2:2] OF direction;
LOCAL
  d : direction := NVL(normalise(ref_direction), dummy_gri || direction([
    1.0, 0.0 ]));
END_LOCAL;
RETURN ([ d, orthogonal_complement(d) ]);
END_FUNCTION; -- 10303-42: geometry_schema

```

```

FUNCTION build_axes (
  axis          : direction;
  ref_direction : direction
) : LIST [3:3] OF direction;
LOCAL
  d1 : direction;
  d2 : direction;
END_LOCAL;
d1 := NVL(normalise(axis), dummy_gri || direction([ 0.0, 0.0, 1.0 ]));
d2 := first_proj_axis(d1, ref_direction);
RETURN ([ d2, normalise(cross_product(d1, d2)).orientation, d1 ]);
END_FUNCTION; -- 10303-42: geometry_schema

```

```

FUNCTION closed_shell_reversed (
  a_shell : closed_shell
) : oriented_closed_shell;
LOCAL
  the_reverse : oriented_closed_shell;
END_LOCAL;
IF 'INTEGRATED_CNC_SCHEMA.ORIENTED_CLOSED_SHELL' IN TYPEOF(a_shell)
  THEN
    the_reverse := dummy_tri || connected_face_set(a_shell\
      connected_face_set.cfs_faces) || closed_shell() ||
      oriented_closed_shell(a_shell\oriented_closed_shell.
        closed_shell_element, NOT a_shell\oriented_closed_shell.orientation
      );
  ELSE
    the_reverse := dummy_tri || connected_face_set(a_shell\
      connected_face_set.cfs_faces) || closed_shell() ||
      oriented_closed_shell(a_shell, FALSE);
  END_IF;
RETURN (the_reverse);
END_FUNCTION; -- 10303-42: topology_schema

```

```

FUNCTION conditional_reverse (
  p          : BOOLEAN;
  an_item    : reversible_topology
) : reversible_topology;
IF p THEN
  RETURN (an_item);
ELSE
  RETURN (topology_reversed(an_item));
END_IF;
END_FUNCTION; -- 10303-42: topology_schema

```

```

FUNCTION constraints_composite_curve_on_surface (
  c : composite_curve_on_surface
) : BOOLEAN;
LOCAL
  n_segments : INTEGER := SIZEOF(c.segments);
END_LOCAL;
REPEAT k := 1 TO n_segments;
  IF (NOT ('INTEGRATED_CNC_SCHEMA.PCURVE' IN TYPEOF(c.composite_curve.
    segments[k].parent_curve)) AND NOT (
    'INTEGRATED_CNC_SCHEMA.SURFACE_CURVE' IN TYPEOF(c.composite_curve.
    segments[k].parent_curve))) AND NOT (
    'INTEGRATED_CNC_SCHEMA.COMPOSITE_CURVE_ON_SURFACE' IN TYPEOF(c\
    composite_curve.segments[k].parent_curve)) THEN
    RETURN (FALSE);
  END_IF;
END_REPEAT;
RETURN (TRUE);
END_FUNCTION; -- 10303-42: geometry_schema

FUNCTION constraints_geometry_shell_based_surface_model (
  m : shell_based_surface_model
) : BOOLEAN;
LOCAL
  result : BOOLEAN := TRUE;
END_LOCAL;
REPEAT j := 1 TO SIZEOF(m.sbsm_boundary);
  IF NOT ('INTEGRATED_CNC_SCHEMA.OPEN_SHELL' IN TYPEOF(m.sbsm_boundary[
    j])) AND NOT ('INTEGRATED_CNC_SCHEMA.CLOSED_SHELL' IN TYPEOF(m.
    sbsm_boundary[j])) THEN
    result := FALSE;
    RETURN (result);
  END_IF;
END_REPEAT;
RETURN (result);
END_FUNCTION; -- 10303-42: geometric_model_schema

FUNCTION constraints_geometry_shell_based_wireframe_model (
  m : shell_based_wireframe_model
) : BOOLEAN;
LOCAL
  result : BOOLEAN := TRUE;
END_LOCAL;
REPEAT j := 1 TO SIZEOF(m.sbwm_boundary);
  IF NOT ('INTEGRATED_CNC_SCHEMA.WIRE_SHELL' IN TYPEOF(m.sbwm_boundary[
    j])) AND NOT ('INTEGRATED_CNC_SCHEMA.VERTEX_SHELL' IN TYPEOF(m.
    sbwm_boundary[j])) THEN
    result := FALSE;
    RETURN (result);
  END_IF;
END_REPEAT;
RETURN (result);
END_FUNCTION; -- 10303-42: geometric_model_schema

```



```

FUNCTION constraints_param_b_spline (
  degree      : INTEGER;
  up_knots    : INTEGER;
  up_cp       : INTEGER;
  knot_mult   : LIST OF INTEGER;
  knots       : LIST OF parameter_value
) : BOOLEAN;
LOCAL
  result : BOOLEAN := TRUE;
  k : INTEGER;
  sum : INTEGER;
END_LOCAL;
sum := knot_mult[1];
REPEAT i := 2 TO up_knots;
  sum := sum + knot_mult[i];
END_REPEAT;
IF ((degree < 1) OR (up_knots < 2)) OR (up_cp < degree) OR (sum <>
  degree + up_cp + 2) THEN
  result := FALSE;
  RETURN (result);
END_IF;
k := knot_mult[1];
IF (k < 1) OR (k > degree + 1) THEN
  result := FALSE;
  RETURN (result);
END_IF;
REPEAT i := 2 TO up_knots;
  IF (knot_mult[i] < 1) OR (knots[i] <= knots[(i - 1)]) THEN
    result := FALSE;
    RETURN (result);
  END_IF;
  k := knot_mult[i];
  IF (i < up_knots) AND (k > degree) THEN
    result := FALSE;
    RETURN (result);
  END_IF;
  IF (i = up_knots) AND (k > degree + 1) THEN
    result := FALSE;
    RETURN (result);
  END_IF;
END_REPEAT;
RETURN (result);
END_FUNCTION; -- 10303-42: geometry_schema

FUNCTION constraints_rectangular_composite_surface (
  s : rectangular_composite_surface
) : BOOLEAN;
REPEAT i := 1 TO s.n_u;
  REPEAT j := 1 TO s.n_v;
    IF NOT (('INTEGRATED_CNC_SCHEMA.B_SPLINE_SURFACE' IN TYPEOF(s.
      segments[i][j].parent_surface)) OR (
      'INTEGRATED_CNC_SCHEMA.RECTANGULAR_TRIMMED_SURFACE' IN TYPEOF(s.
      segments[i][j].parent_surface))) THEN
      RETURN (FALSE);
    END_IF;
  END_REPEAT;
END_REPEAT;

```

```

        END_IF;
    END_REPEAT;
END_REPEAT;
REPEAT i := 1 TO s.n_u - 1;
    REPEAT j := 1 TO s.n_v;
        IF s.segments[i][j].u_transition = discontinuous THEN
            RETURN (FALSE);
        END_IF;
    END_REPEAT;
END_REPEAT;
REPEAT i := 1 TO s.n_u;
    REPEAT j := 1 TO s.n_v - 1;
        IF s.segments[i][j].v_transition = discontinuous THEN
            RETURN (FALSE);
        END_IF;
    END_REPEAT;
END_REPEAT;
RETURN (TRUE);
END_FUNCTION; -- 10303-42: geometry_schema

FUNCTION cross_product (
    arg1 : direction;
    arg2 : direction
) : vector;
LOCAL
    mag : REAL;
    res : direction;
    v1 : LIST [3:3] OF REAL;
    v2 : LIST [3:3] OF REAL;
    result : vector;
END_LOCAL;
IF (NOT EXISTS(arg1) OR (arg1.dim = 2)) OR (NOT EXISTS(arg2) OR (arg2.
    dim = 2)) THEN
    RETURN (?);
ELSE
    BEGIN
        v1 := normalise(arg1).direction_ratios;
        v2 := normalise(arg2).direction_ratios;
        res := dummy_gri || direction([ (v1[2] * v2[3] - v1[3] * v2[2]), (
            v1[3] * v2[1] - v1[1] * v2[3]), (v1[1] * v2[2] - v1[2] * v2[1]) ]
        );
        mag := 0.0;
        REPEAT i := 1 TO 3;
            mag := mag + res.direction_ratios[i] * res.direction_ratios[i];
        END_REPEAT;
        IF mag > 0.0 THEN
            result := dummy_gri || vector(res, sqrt(mag));
        ELSE
            result := dummy_gri || vector(arg1, 0.0);
        END_IF;
        RETURN (result);
    END;
END_IF;
END_FUNCTION; -- 10303-42: geometry_schema

```

```

FUNCTION curve_weights_positive (
  b : rational_b_spline_curve
) : BOOLEAN;
LOCAL
  result : BOOLEAN := TRUE;
END_LOCAL;
REPEAT i := 0 TO b.upper_index_on_control_points;
  IF b.weights[i] <= 0.0 THEN
    result := FALSE;
    RETURN (result);
  END_IF;
END_REPEAT;
RETURN (result);
END_FUNCTION; -- 10303-42: geometry_schema

FUNCTION derive_dimensional_exponents (
  x : unit
) : dimensional_exponents;
LOCAL
  result : dimensional_exponents := dimensional_exponents(0.0, 0.0, 0.0,
    0.0, 0.0, 0.0, 0.0);
END_LOCAL;
IF 'INTEGRATED_CNC_SCHEMA.DERIVED_UNIT' IN TYPEOF(x) THEN
  REPEAT i := LOINDEX(x.elements) TO HIINDEX(x.elements);
    result.length_exponent := result.length_exponent + x.elements[i].
      exponent * x.elements[i].unit.dimensions.length_exponent;
    result.mass_exponent := result.mass_exponent + x.elements[i].
      exponent * x.elements[i].unit.dimensions.mass_exponent;
    result.time_exponent := result.time_exponent + x.elements[i].
      exponent * x.elements[i].unit.dimensions.time_exponent;
    result.electric_current_exponent := result.
      electric_current_exponent + x.elements[i].exponent * x.elements[i].
      unit.dimensions.electric_current_exponent;
    result.thermodynamic_temperature_exponent := result.
      thermodynamic_temperature_exponent + x.elements[i].exponent * x.
      elements[i].unit.dimensions.thermodynamic_temperature_exponent;
    result.amount_of_substance_exponent := result.
      amount_of_substance_exponent + x.elements[i].exponent * x.
      elements[i].unit.dimensions.amount_of_substance_exponent;
    result.luminous_intensity_exponent := result.
      luminous_intensity_exponent + x.elements[i].exponent * x.elements
      [i].unit.dimensions.luminous_intensity_exponent;
  END_REPEAT;
ELSE
  result := x.dimensions;
END_IF;
RETURN (result);
END_FUNCTION; -- 10303-41: measure_schema

FUNCTION dimension_of (
  item : geometric_representation_item
) : dimension_count;
LOCAL

```

```

x : SET OF representation;
y : representation_context;
dim : dimension_count;
END_LOCAL;
IF 'INTEGRATED_CNC_SCHEMA.CARTESIAN_POINT' IN TYPEOF(item) THEN
  dim := SIZEOF(item\cartesian_point.coordinates);
  RETURN (dim);
END_IF;
IF 'INTEGRATED_CNC_SCHEMA.DIRECTION' IN TYPEOF(item) THEN
  dim := SIZEOF(item\direction.direction_ratios);
  RETURN (dim);
END_IF;
IF 'INTEGRATED_CNC_SCHEMA.VECTOR' IN TYPEOF(item) THEN
  dim := SIZEOF(item\vector.orientation\direction.direction_ratios);
  RETURN (dim);
END_IF;
x := using_representations(item);
y := x[1].context_of_items;
dim := y\geometric_representation_context.coordinate_space_dimension;
RETURN (dim);
END_FUNCTION; -- 10303-42: geometry_schema

FUNCTION dimensions_for_si_unit (
  n : si_unit_name
) : dimensional_exponents;
CASE n OF
  metre :
    RETURN (dimensional_exponents(1.0, 0.0, 0.0, 0.0, 0.0, 0.0, 0.0))
    ;
  gram :
    RETURN (dimensional_exponents(0.0, 1.0, 0.0, 0.0, 0.0, 0.0, 0.0))
    ;
  second :
    RETURN (dimensional_exponents(0.0, 0.0, 1.0, 0.0, 0.0, 0.0, 0.0))
    ;
  ampere :
    RETURN (dimensional_exponents(0.0, 0.0, 0.0, 1.0, 0.0, 0.0, 0.0))
    ;
  kelvin :
    RETURN (dimensional_exponents(0.0, 0.0, 0.0, 0.0, 1.0, 0.0, 0.0))
    ;
  mole :
    RETURN (dimensional_exponents(0.0, 0.0, 0.0, 0.0, 0.0, 1.0, 0.0))
    ;
  candela :
    RETURN (dimensional_exponents(0.0, 0.0, 0.0, 0.0, 0.0, 0.0, 1.0))
    ;
  radian :
    RETURN (dimensional_exponents(0.0, 0.0, 0.0, 0.0, 0.0, 0.0, 0.0))
    ;
  steradian :
    RETURN (dimensional_exponents(0.0, 0.0, 0.0, 0.0, 0.0, 0.0, 0.0))
    ;
  hertz :

```

```

RETURN (dimensional_exponents(0.0, 0.0, -1.0, 0.0, 0.0, 0.0, 0.0)
);
newton :
RETURN (dimensional_exponents(1.0, 1.0, -2.0, 0.0, 0.0, 0.0, 0.0)
);
pascal :
RETURN (dimensional_exponents(-1.0, 1.0, -2.0, 0.0, 0.0, 0.0, 0.0
));
joule :
RETURN (dimensional_exponents(2.0, 1.0, -2.0, 0.0, 0.0, 0.0, 0.0)
);
watt :
RETURN (dimensional_exponents(2.0, 1.0, -3.0, 0.0, 0.0, 0.0, 0.0)
);
coulomb :
RETURN (dimensional_exponents(0.0, 0.0, 1.0, 1.0, 0.0, 0.0, 0.0))
;
volt :
RETURN (dimensional_exponents(2.0, 1.0, -3.0, -1.0, 0.0, 0.0, 0.0
));
farad :
RETURN (dimensional_exponents(-2.0, -1.0, 4.0, 1.0, 0.0, 0.0, 0.0
));
ohm :
RETURN (dimensional_exponents(2.0, 1.0, -3.0, -2.0, 0.0, 0.0, 0.0
));
siemens :
RETURN (dimensional_exponents(-2.0, -1.0, 3.0, 2.0, 0.0, 0.0, 0.0
));
weber :
RETURN (dimensional_exponents(2.0, 1.0, -2.0, -1.0, 0.0, 0.0, 0.0
));
tesla :
RETURN (dimensional_exponents(0.0, 1.0, -2.0, -1.0, 0.0, 0.0, 0.0
));
henry :
RETURN (dimensional_exponents(2.0, 1.0, -2.0, -2.0, 0.0, 0.0, 0.0
));
degree_celsius :
RETURN (dimensional_exponents(0.0, 0.0, 0.0, 0.0, 1.0, 0.0, 0.0))
;
lumen :
RETURN (dimensional_exponents(0.0, 0.0, 0.0, 0.0, 0.0, 0.0, 1.0))
;
lux :
RETURN (dimensional_exponents(-2.0, 0.0, 0.0, 0.0, 0.0, 0.0, 1.0)
);
becquerel :
RETURN (dimensional_exponents(0.0, 0.0, -1.0, 0.0, 0.0, 0.0, 0.0)
);
gray :
RETURN (dimensional_exponents(2.0, 0.0, -2.0, 0.0, 0.0, 0.0, 0.0)
);
sievert :

```

```

        RETURN (dimensional_exponents(2.0, 0.0, -2.0, 0.0, 0.0, 0.0, 0.0)
        );
    OTHERWISE :
        RETURN (?);
    END_CASE;
END_FUNCTION; -- 10303-41: measure_schema

FUNCTION dot_product (
    arg1 : direction;
    arg2 : direction
) : REAL;
LOCAL
    scalar : REAL;
    vec1 : direction;
    vec2 : direction;
    ndim : INTEGER;
END_LOCAL;
IF NOT EXISTS(arg1) OR NOT EXISTS(arg2) THEN
    scalar := ?;
ELSE
    IF arg1.dim <> arg2.dim THEN
        scalar := ?;
    ELSE
        BEGIN
            vec1 := normalise(arg1);
            vec2 := normalise(arg2);
            ndim := arg1.dim;
            scalar := 0.0;
            REPEAT i := 1 TO ndim;
                scalar := scalar + vec1.direction_ratios[i] * vec2.
                    direction_ratios[i];
            END_REPEAT;
        END;
    END_IF;
END_IF;
RETURN (scalar);
END_FUNCTION; -- 10303-42: geometry_schema

FUNCTION edge_reversed (
    an_edge : edge
) : oriented_edge;
LOCAL
    the_reverse : oriented_edge;
END_LOCAL;
IF 'INTEGRATED_CNC_SCHEMA.ORIENTED_EDGE' IN TYPEOF(an_edge) THEN
    the_reverse := dummy_tri || edge(an_edge.edge_end, an_edge.edge_start
        ) || oriented_edge(an_edge\oriented_edge.edge_element, NOT an_edge\
            oriented_edge.orientation);
ELSE
    the_reverse := dummy_tri || edge(an_edge.edge_end, an_edge.edge_start
        ) || oriented_edge(an_edge, FALSE);
END_IF;
RETURN (the_reverse);
END_FUNCTION; -- 10303-42: topology_schema

```

```

FUNCTION face_bound_reversed (
  a_face_bound : face_bound
) : face_bound;
LOCAL
  the_reverse : face_bound;
END_LOCAL;
IF 'INTEGRATED_CNC_SCHEMA.FACE_OUTER_BOUND' IN TYPEOF(a_face_bound)
  THEN
    the_reverse := dummy_tri || face_bound(a_face_bound\face_bound.bound,
      NOT a_face_bound\face_bound.orientation) || face_outer_bound();
  ELSE
    the_reverse := dummy_tri || face_bound(a_face_bound.bound, NOT
      a_face_bound.orientation);
  END_IF;
RETURN (the_reverse);
END_FUNCTION; -- 10303-42: topology_schema

FUNCTION face_reversed (
  a_face : face
) : oriented_face;
LOCAL
  the_reverse : oriented_face;
END_LOCAL;
IF 'INTEGRATED_CNC_SCHEMA.ORIENTED_FACE' IN TYPEOF(a_face) THEN
  the_reverse := dummy_tri || face(set_of_topology_reversed(a_face.
    bounds)) || oriented_face(a_face\oriented_face.face_element, NOT
    a_face\oriented_face.orientation);
  ELSE
    the_reverse := dummy_tri || face(set_of_topology_reversed(a_face.
    bounds)) || oriented_face(a_face, FALSE);
  END_IF;
RETURN (the_reverse);
END_FUNCTION; -- 10303-42: topology_schema

FUNCTION first_proj_axis (
  z_axis : direction;
  arg    : direction
) : direction;
LOCAL
  x_axis : direction;
  v      : direction;
  z      : direction;
  x_vec  : vector;
END_LOCAL;
IF NOT EXISTS(z_axis) THEN
  RETURN (?);
  ELSE
    z := normalise(z_axis);
    IF NOT EXISTS(arg) THEN
      IF (z.direction_ratios <> [ 1.0, 0.0, 0.0 ]) AND (z.
        direction_ratios <> [ -1.0, 0.0, 0.0 ]) THEN
        v := dummy_gri || direction([ 1.0, 0.0, 0.0 ]);
      ELSE

```

```

        v := dummy_gri || direction([ 0.0, 1.0, 0.0 ]);
    END_IF;
ELSE
    IF arg.dim <> 3 THEN
        RETURN (?);
    END_IF;
    IF cross_product(arg, z).magnitude = 0.0 THEN
        RETURN (?);
    ELSE
        v := normalise(arg);
    END_IF;
END_IF;
x_vec := scalar_times_vector(dot_product(v, z), z);
x_axis := vector_difference(v, x_vec).orientation;
x_axis := normalise(x_axis);
END_IF;
RETURN (x_axis);
END_FUNCTION; -- 10303-42: geometry_schema

FUNCTION gbsf_check_curve (
    cv : representation_item
) : BOOLEAN;
IF SIZEOF([ 'INTEGRATED_CNC_SCHEMA.BOUNDED_CURVE',
    'INTEGRATED_CNC_SCHEMA.CONIC', 'INTEGRATED_CNC_SCHEMA.CURVE_REPLICA',
    'INTEGRATED_CNC_SCHEMA.LINE',
    'INTEGRATED_CNC_SCHEMA.OFFSET_CURVE_3D' ] * TYPEOF(cv)) > 1 THEN
    RETURN (FALSE);
END_IF;
IF SIZEOF([ 'INTEGRATED_CNC_SCHEMA.CIRCLE',
    'INTEGRATED_CNC_SCHEMA.ELLIPSE',
    'INTEGRATED_CNC_SCHEMA.TRIMMED_CURVE' ] * TYPEOF(cv)) = 1 THEN
    RETURN (TRUE);
ELSE
    IF ('INTEGRATED_CNC_SCHEMA.B_SPLINE_CURVE' IN TYPEOF(cv)) AND (cv\
        b_spline_curve.self_intersect = FALSE) OR (cv\b_spline_curve.
        self_intersect = UNKNOWN) THEN
        RETURN (TRUE);
    ELSE
        IF ('INTEGRATED_CNC_SCHEMA.COMPOSITE_CURVE' IN TYPEOF(cv)) AND (cv\
            composite_curve.self_intersect = FALSE) OR (cv\composite_curve.
            self_intersect = UNKNOWN) THEN
            RETURN (SIZEOF(QUERY (seg <* cv\composite_curve.segments| NOT
                gbsf_check_curve(seg.parent_curve))) = 0);
        ELSE
            IF 'INTEGRATED_CNC_SCHEMA.CURVE_REPLICA' IN TYPEOF(cv) THEN
                RETURN (gbsf_check_curve(cv\curve_replica.parent_curve));
            ELSE
                IF (('INTEGRATED_CNC_SCHEMA.OFFSET_CURVE_3D' IN TYPEOF(cv)) AND
                    ((cv\offset_curve_3d.self_intersect = FALSE) OR (cv\
                    offset_curve_3d.self_intersect = UNKNOWN))) AND NOT (
                    'INTEGRATED_CNC_SCHEMA.POLYLINE' IN TYPEOF(cv\offset_curve_3d
                    .basis_curve)) THEN
                    RETURN (gbsf_check_curve(cv\offset_curve_3d.basis_curve));
                ELSE

```





```

    RETURN (gbsf_check_surface(pnt\point_on_surface.basis_surface));
ELSE
    IF 'INTEGRATED_CNC_SCHEMA.DEGENERATE_PCURVE' IN TYPEOF(pnt) THEN
        RETURN (gbsf_check_curve(pnt\degenerate_pcurve.
            reference_to_curve\representation.items[1]) AND
            gbsf_check_surface(pnt\degenerate_pcurve.basis_surface));
    END_IF;
END_IF;
END_IF;
END_IF;
RETURN (FALSE);
END_FUNCTION; -- 10303-507: aic_geometrically_bounded_surface

```

```

FUNCTION gbsf_check_surface (
    sf : surface
) : BOOLEAN;
IF ('INTEGRATED_CNC_SCHEMA.B_SPLINE_SURFACE' IN TYPEOF(sf)) AND (sf\
    b_spline_surface.self_intersect = FALSE) OR (sf\b_spline_surface.
    self_intersect = UNKNOWN) THEN
    RETURN (TRUE);
ELSE
    IF SIZEOF([ 'INTEGRATED_CNC_SCHEMA.SPHERICAL_SURFACE',
        'INTEGRATED_CNC_SCHEMA.TOROIDAL_SURFACE',
        'INTEGRATED_CNC_SCHEMA.CURVE_BOUNDED_SURFACE',
        'INTEGRATED_CNC_SCHEMA.RECTANGULAR_TRIMMED_SURFACE' ] * TYPEOF(sf))
        = 1 THEN
        RETURN (TRUE);
    ELSE
        IF ('INTEGRATED_CNC_SCHEMA.OFFSET_SURFACE' IN TYPEOF(sf)) AND (sf\
            offset_surface.self_intersect = FALSE) OR (sf\offset_surface.
            self_intersect = UNKNOWN) THEN
            RETURN (gbsf_check_surface(sf\offset_surface.basis_surface));
        ELSE
            IF 'INTEGRATED_CNC_SCHEMA.RECTANGULAR_COMPOSITE_SURFACE' IN
                TYPEOF(sf) THEN
                REPEAT i := 1 TO SIZEOF(sf\rectangular_composite_surface.
                    segments);
                    REPEAT j := 1 TO SIZEOF(sf\rectangular_composite_surface.
                        segments[i]);
                        IF NOT gbsf_check_surface(sf\rectangular_composite_surface.
                            segments[i][j].parent_surface) THEN
                            RETURN (FALSE);
                        END_IF;
                    END_REPEAT;
                END_REPEAT;
                RETURN (TRUE);
            ELSE
                IF 'INTEGRATED_CNC_SCHEMA.SURFACE_REPLICA' IN TYPEOF(sf) THEN
                    RETURN (gbsf_check_surface(sf\surface_replica.parent_surface)
                        );
                ELSE
                    IF 'INTEGRATED_CNC_SCHEMA.SURFACE_OF_REVOLUTION' IN TYPEOF(sf
                        ) THEN
                        RETURN (gbsf_check_curve(sf\swept_surface.swept_curve));
                    END_IF;
                END_IF;
            END_IF;
        END_IF;
    END_IF;
END_FUNCTION;

```

```

        END_IF;
    END_IF;
    END_IF;
    END_IF;
    END_IF;
    RETURN (FALSE);
END_FUNCTION; -- 10303-507: aic_geometrically_bounded_surface

FUNCTION get_action_property (
    cad :      characterized_action_definition;
    prop_name : STRING
): SET OF action_property;

    RETURN (bag_to_set (QUERY (ap < *
        USEDIN (cad, 'INTEGRATED_CNC_SCHEMA.ACTION_PROPERTY.DEFINITION') |
        (ap.name = prop_name))));
END_FUNCTION; -- 10303-238: integrated_cnc_schema

FUNCTION get_basis_surface (
    c : curve_on_surface
) : SET [0:2] OF surface;
LOCAL
    surfs : SET [0:2] OF surface;
    n : INTEGER;
END_LOCAL;
surfs := [];
IF 'INTEGRATED_CNC_SCHEMA.PCURVE' IN TYPEOF(c) THEN
    surfs := [ c\pcurve.basis_surface ];
ELSE
    IF 'INTEGRATED_CNC_SCHEMA.SURFACE_CURVE' IN TYPEOF(c) THEN
        n := SIZEOF(c\surface_curve.associated_geometry);
        REPEAT i := 1 TO n;
            surfs := surfs + associated_surface(c\surface_curve.
                associated_geometry[i]);
        END_REPEAT;
    END_IF;
END_IF;
IF 'INTEGRATED_CNC_SCHEMA.COMPOSITE_CURVE_ON_SURFACE' IN TYPEOF(c) THEN
    n := SIZEOF(c\composite_curve.segments);
    surfs := get_basis_surface(c\composite_curve.segments[1].parent_curve
);
    IF n > 1 THEN
        REPEAT i := 2 TO n;
            surfs := surfs * get_basis_surface(c\composite_curve.segments[i].
                parent_curve);
        END_REPEAT;
    END_IF;
END_IF;
RETURN (surfs);
END_FUNCTION; -- 10303-42: geometry_schema

FUNCTION get_count_of_relatng_amr (
    am :      action_method;

```

ISO 10303-238:2007(E)

```

amr_types : SET OF STRING
): INTEGER;

RETURN (SIZEOF (QUERY (amr <* get_relating_amr (am) |
    (SIZEOF(amr_types * TYPEOF(amr)) =
    SIZEOF(amr_types)) ))) ;
END_FUNCTION; -- 10303-238: integrated_cnc_schema

FUNCTION get_count_of_relating_amr_with_name (
    am :          action_method;
    amr_name :   STRING;
    amr_types : SET OF STRING
): INTEGER;

RETURN (SIZEOF (QUERY (amr <* get_relating_amr (am) |
    ((amr.name = amr_name) AND
    (SIZEOF(amr_types * TYPEOF(amr)) =
    SIZEOF(amr_types)) ))) );
END_FUNCTION; -- 10303-238: integrated_cnc_schema

FUNCTION get_description_value (
    obj : description_attribute_select
) : text;
LOCAL
    description_bag : BAG OF description_attribute := USEDIN(obj,
        'INTEGRATED_CNC_SCHEMA.' + 'DESCRIPTION_ATTRIBUTE.' +
        'DESCRIBED_ITEM');
END_LOCAL;
IF SIZEOF(description_bag) = 1 THEN
    RETURN (description_bag[1].attribute_value);
ELSE
    RETURN (?);
END_IF;
END_FUNCTION; -- 10303-41: basic_attribute_schema

FUNCTION get_id_value (
    obj : id_attribute_select
) : identifier;
LOCAL
    id_bag : BAG OF id_attribute := USEDIN(obj, 'INTEGRATED_CNC_SCHEMA.' +
        'ID_ATTRIBUTE.' + 'IDENTIFIED_ITEM');
END_LOCAL;
IF SIZEOF(id_bag) = 1 THEN
    RETURN (id_bag[1].attribute_value);
ELSE
    RETURN (?);
END_IF;
END_FUNCTION; -- 10303-41: basic_attribute_schema

FUNCTION get_name_value (
    obj : name_attribute_select
) : label;
LOCAL
    name_bag : BAG OF name_attribute := USEDIN(obj,

```

```

        'INTEGRATED_CNC_SCHEMA.' + 'NAME_ATTRIBUTE.' + 'NAMED_ITEM');
END_LOCAL;
IF SIZEOF(name_bag) = 1 THEN
    RETURN (name_bag[1].attribute_value);
ELSE
    RETURN (?);
END_IF;
END_FUNCTION; -- 10303-41: basic_attribute_schema

FUNCTION get_property_definition_representations (
    c_def_instance : characterized_definition
) : SET OF property_definition_representation;
LOCAL
    pd_set : SET OF property_definition := [];
    pdr_set : SET OF property_definition_representation := [];
END_LOCAL;
pd_set := bag_to_set(USEDIN(c_def_instance,
    'INTEGRATED_CNC_SCHEMA.PROPERTY_DEFINITION.DEFINITION'));
IF SIZEOF(pd_set) < 1 THEN
    RETURN (pdr_set);
END_IF;
REPEAT i := 1 TO HIINDEX(pd_set);
    pdr_set := pdr_set + bag_to_set(USEDIN(pd_set[i],
        'INTEGRATED_CNC_SCHEMA.PROPERTY_DEFINITION_REPRESENTATION.DEFINITION'
    ));
END_REPEAT;
RETURN (pdr_set);
END_FUNCTION; -- 10303-41: product_property_representation_schema

FUNCTION get_relating_amr (
    am : action_method
) : SET OF action_method_relationship;

RETURN (bag_to_set (USEDIN (am,
    'INTEGRATED_CNC_SCHEMA.ACTION_METHOD_RELATIONSHIP.RELATING_METHOD')));
END_FUNCTION; -- 10303-238: integrated_cnc_schema

FUNCTION get_resource_property (
    crd : characterized_resource_definition;
    prop_name : STRING
): SET OF resource_property;

RETURN (bag_to_set (QUERY (rp < *
    USEDIN (crd, 'INTEGRATED_CNC_SCHEMA.RESOURCE_PROPERTY.RESOURCE') |
    (rp.name = prop_name))));
END_FUNCTION; -- 10303-238: integrated_cnc_schema

FUNCTION get_role (
    obj : role_select
) : object_role;
LOCAL
    role_bag : BAG OF role_association := USEDIN(obj,
        'INTEGRATED_CNC_SCHEMA.' + 'ROLE_ASSOCIATION.' + 'ITEM_WITH_ROLE');
END_LOCAL;

```

ISO 10303-238:2007(E)

```

IF SIZEOF(role_bag) = 1 THEN
    RETURN (role_bag[1].role);
ELSE
    RETURN (?);
END_IF;
END_FUNCTION; -- 10303-41: basic_attribute_schema

FUNCTION get_tool_body_item (
    mt :          machining_tool;
    prop_name :   STRING
): SET OF representation_item;

LOCAL
    props : SET OF resource_property;
    preps : SET OF resource_property_representation;
    items : SET OF representation_item;
END_LOCAL;

props := get_resource_property (mt, 'tool body');
REPEAT i := 1 TO HIINDEX(props);
    preps := preps + USEDIN (props[i], 'INTEGRATED_CNC_SCHEMA.'+
        'RESOURCE_PROPERTY_REPRESENTATION.PROPERTY');
END_REPEAT;

REPEAT i := 1 TO HIINDEX(preps);
    IF ('INTEGRATED_CNC_SCHEMA.MACHINING_TOOL_BODY_REPRESENTATION'
        IN TYPEOF (preps[i].representation))
    THEN
        items := items + preps[i].representation.items;
    END_IF;
END_REPEAT;

RETURN (bag_to_set (QUERY (it <* items | (it.name = prop_name))));
END_FUNCTION; -- 10303-238: integrated_cnc_schema

FUNCTION is_acyclic (
    arg : generic_expression
) : BOOLEAN;
RETURN (acyclic(arg, []));
END_FUNCTION; -- 13584-20: iso13584_generic_expressions_schema

FUNCTION is_int_expr (
    arg : numeric_expression
) : BOOLEAN;

IF 'INTEGRATED_CNC_SCHEMA.INT_LITERAL' IN TYPEOF(arg) THEN
    RETURN (TRUE);
END_IF;
IF 'INTEGRATED_CNC_SCHEMA.REAL_LITERAL' IN TYPEOF(arg) THEN
    RETURN (FALSE);
END_IF;
IF 'INTEGRATED_CNC_SCHEMA.INT_NUMERIC_VARIABLE' IN TYPEOF(arg) THEN
    RETURN (TRUE);
END_IF;

```

```

    IF 'INTEGRATED_CNC_SCHEMA.REAL_NUMERIC_VARIABLE' IN TYPEOF(arg) THEN
        RETURN (FALSE);
    END_IF;
    RETURN (FALSE);
END_FUNCTION; -- 13584-20: iso13584_expressions_schema

FUNCTION is_SQL_mappable (
    arg : expression
) : BOOLEAN;

    IF 'INTEGRATED_CNC_SCHEMA.SIMPLE_NUMERIC_EXPRESSION' IN TYPEOF(arg)
        THEN
            RETURN (TRUE);
        END_IF;
    IF 'INTEGRATED_CNC_SCHEMA.NOT_EXPRESSION' IN TYPEOF(arg) THEN
        RETURN (is_SQL_mappable(arg\unary_generic_expression.operand));
    END_IF;
    IF ('INTEGRATED_CNC_SCHEMA.XOR_EXPRESSION' IN TYPEOF(arg)) THEN
        RETURN (FALSE);
    END_IF;
    IF ('INTEGRATED_CNC_SCHEMA.AND_EXPRESSION' IN TYPEOF(arg)) OR (
        'INTEGRATED_CNC_SCHEMA.OR_EXPRESSION' IN TYPEOF(arg)) THEN
        REPEAT i := 1 TO SIZEOF(arg\multiple_arity_boolean_expression.
            operands);
            IF NOT is_SQL_mappable(arg\multiple_arity_boolean_expression.
                operands[i]) THEN
                RETURN (FALSE);
            END_IF;
        END_REPEAT;
        RETURN (TRUE);
    END_IF;
    IF ((((((('INTEGRATED_CNC_SCHEMA.COMPARISON_EQUAL' IN TYPEOF(arg)) OR (
        'INTEGRATED_CNC_SCHEMA.COMPARISON_GREATER' IN TYPEOF(arg))) OR (
        'INTEGRATED_CNC_SCHEMA.COMPARISON_GREATER_EQUAL' IN TYPEOF(arg))) OR
        ('INTEGRATED_CNC_SCHEMA.COMPARISON_LESS' IN TYPEOF(arg))) OR (
        'INTEGRATED_CNC_SCHEMA.COMPARISON_LESS_EQUAL' IN TYPEOF(arg))) OR (
        'INTEGRATED_CNC_SCHEMA.COMPARISON_NOT_EQUAL' IN TYPEOF(arg))) THEN
        RETURN (is_SQL_mappable(arg\comparison_expression.operands[1]) AND
            is_SQL_mappable(arg\comparison_expression.operands[2]));
    END_IF;
    RETURN (FALSE);
END_FUNCTION; -- 13584-20: iso13584_expressions_schema

FUNCTION item_in_context (
    item : representation_item;
    cntxt : representation_context
) : BOOLEAN;
LOCAL
    y : BAG OF representation_item;
END_LOCAL;
    IF SIZEOF(USEDIN(item, 'INTEGRATED_CNC_SCHEMA.REPRESENTATION.ITEMS') *
        cntxt.representations_in_context) > 0 THEN
        RETURN (TRUE);
    ELSE

```

```

y := QUERY (z <* USEDIN(item, '' |
'INTEGRATED_CNC_SCHEMA.REPRESENTATION_ITEM' IN TYPEOF(z));
IF SIZEOF(y) > 0 THEN
  REPEAT i := 1 TO HIINDEX(y);
    IF item_in_context(y[i], cntxt) THEN
      RETURN (TRUE);
    END_IF;
  END_REPEAT;
END_IF;
RETURN (FALSE);
END_FUNCTION; -- 10303-43: representation_schema

FUNCTION leap_year (
  year : year_number
) : BOOLEAN;
IF (year MOD 4 = 0) AND (year MOD 100 <> 0) OR (year MOD 400 = 0) THEN
  RETURN (TRUE);
ELSE
  RETURN (FALSE);
END_IF;
END_FUNCTION; -- 10303-41: date_time_schema

FUNCTION list_face_loops (
  f : face
) : LIST [0:?] OF loop;
LOCAL
  loops : LIST [0:?] OF loop := [];
END_LOCAL;
REPEAT i := 1 TO SIZEOF(f.bounds);
  loops := loops + f.bounds[i].bound;
END_REPEAT;
RETURN (loops);
END_FUNCTION; -- 10303-42: topology_schema

FUNCTION list_of_topology_reversed (
  a_list : list_of_reversible_topology_item
) : list_of_reversible_topology_item;
LOCAL
  the_reverse : list_of_reversible_topology_item;
END_LOCAL;
the_reverse := [];
REPEAT i := 1 TO SIZEOF(a_list);
  the_reverse := topology_reversed(a_list[i]) + the_reverse;
END_REPEAT;
RETURN (the_reverse);
END_FUNCTION; -- 10303-42: topology_schema

FUNCTION list_to_array (
  lis : LIST [0:?] OF GENERIC : T;
  low : INTEGER;
  u : INTEGER
) : ARRAY [low:u] OF GENERIC : T;
LOCAL

```



```

n : INTEGER;
res : ARRAY [low:u] OF GENERIC : T;
END_LOCAL;
n := SIZEOF(lis);
IF n <> u - low + 1 THEN
  RETURN (?);
ELSE
  res := [ lis[1] ];
  REPEAT i := 2 TO n;
    res[(low + i - 1)] := lis[i];
  END_REPEAT;
  RETURN (res);
END_IF;
END_FUNCTION; -- 10303-42: geometry_schema

FUNCTION list_to_set (
  l : LIST [0:?] OF GENERIC : T
) : SET OF GENERIC : T;
LOCAL
  s : SET OF GENERIC : T := [];
END_LOCAL;
REPEAT i := 1 TO SIZEOF(l);
  s := s + l[i];
END_REPEAT;
RETURN (s);
END_FUNCTION; -- 10303-42: topology_schema

FUNCTION make_array_of_array (
  lis : LIST [1:?] OF LIST [1:?] OF GENERIC : T;
  low1 : INTEGER;
  u1 : INTEGER;
  low2 : INTEGER;
  u2 : INTEGER
) : ARRAY [low1:u1] OF ARRAY [low2:u2] OF GENERIC : T;
LOCAL
  res : ARRAY [low1:u1] OF ARRAY [low2:u2] OF GENERIC : T;
END_LOCAL;
IF u1 - low1 + 1 <> SIZEOF(lis) THEN
  RETURN (?);
END_IF;
IF u2 - low2 + 1 <> SIZEOF(lis[1]) THEN
  RETURN (?);
END_IF;
res := [ list_to_array(lis[1], low2, u2) ];
REPEAT i := 2 TO HIINDEX(lis);
  IF u2 - low2 + 1 <> SIZEOF(lis[i]) THEN
    RETURN (?);
  END_IF;
  res[(low1 + i - 1)] := list_to_array(lis[i], low2, u2);
END_REPEAT;
RETURN (res);
END_FUNCTION; -- 10303-42: geometry_schema

FUNCTION mixed_loop_type_set (

```

ISO 10303-238:2007(E)

```

    l : SET [0:?] OF loop
  ) : LOGICAL;
LOCAL
  poly_loop_type : LOGICAL;
END_LOCAL;
  IF SIZEOF(l) <= 1 THEN
    RETURN (FALSE);
  END_IF;
  poly_loop_type := 'INTEGRATED_CNC_SCHEMA.POLY_LOOP' IN TYPEOF(l[1]);
  REPEAT i := 2 TO SIZEOF(l);
    IF ('INTEGRATED_CNC_SCHEMA.POLY_LOOP' IN TYPEOF(l[i])) <>
      poly_loop_type THEN
      RETURN (TRUE);
    END_IF;
  END_REPEAT;
  RETURN (FALSE);
END_FUNCTION; -- 10303-42: topology_schema

FUNCTION msb_shells (
  brep : manifold_solid_brep
) : SET [1:?] OF closed_shell;
  IF SIZEOF(QUERY (msbtype <* TYPEOF(brep) | msbtype LIKE
  '*BREP_WITH_VOIDS')) >= 1 THEN
    RETURN (brep\brep_with_voids.voids + brep.outer);
  ELSE
    RETURN ([ brep.outer ]);
  END_IF;
END_FUNCTION; -- 10303-42: geometric_model_schema

FUNCTION msf_curve_check (
  cv : representation_item
) : BOOLEAN;
  IF SIZEOF([ 'INTEGRATED_CNC_SCHEMA.BOUNDED_CURVE',
  'INTEGRATED_CNC_SCHEMA.CONIC', 'INTEGRATED_CNC_SCHEMA.CURVE_REPLICA',
  'INTEGRATED_CNC_SCHEMA.LINE',
  'INTEGRATED_CNC_SCHEMA.OFFSET_CURVE_3D' ] * TYPEOF(cv)) > 1 THEN
    RETURN (FALSE);
  END_IF;
  IF ('INTEGRATED_CNC_SCHEMA.B_SPLINE_CURVE' IN TYPEOF(cv)) AND (cv\
  b_spline_curve.self_intersect = FALSE) OR (cv\b_spline_curve.
  self_intersect = UNKNOWN) THEN
    RETURN (TRUE);
  ELSE
    IF SIZEOF([ 'INTEGRATED_CNC_SCHEMA.CONIC',
    'INTEGRATED_CNC_SCHEMA.LINE' ] * TYPEOF(cv)) = 1 THEN
      RETURN (TRUE);
    ELSE
      IF 'INTEGRATED_CNC_SCHEMA.CURVE_REPLICA' IN TYPEOF(cv) THEN
        RETURN (msf_curve_check(cv\curve_replica.parent_curve));
      ELSE
        IF (('INTEGRATED_CNC_SCHEMA.OFFSET_CURVE_3D' IN TYPEOF(cv)) AND (
        (cv\offset_curve_3d.self_intersect = FALSE) OR (cv\
        offset_curve_3d.self_intersect = UNKNOWN))) AND NOT (
        'INTEGRATED_CNC_SCHEMA.POLYLINE' IN TYPEOF(cv\offset_curve_3d.

```

```

basis_curve)) THEN
RETURN (msf_curve_check(cv\offset_curve_3d.basis_curve));
ELSE
IF 'INTEGRATED_CNC_SCHEMA.PCURVE' IN TYPEOF(cv) THEN
RETURN (msf_curve_check(cv\pcurve.reference_to_curve\
representation.items[1]) AND msf_surface_check(cv\pcurve.
basis_surface));
ELSE
IF 'INTEGRATED_CNC_SCHEMA.SURFACE_CURVE' IN TYPEOF(cv) THEN
IF msf_curve_check(cv\surface_curve.curve_3d) THEN
REPEAT i := 1 TO SIZEOF(cv\surface_curve.
associated_geometry);
IF 'INTEGRATED_CNC_SCHEMA.SURFACE' IN TYPEOF(cv\
surface_curve.associated_geometry[i]) THEN
IF NOT msf_surface_check(cv\surface_curve.
associated_geometry[i]) THEN
RETURN (FALSE);
END_IF;
ELSE
IF 'INTEGRATED_CNC_SCHEMA.PCURVE' IN TYPEOF(cv\
surface_curve.associated_geometry[i]) THEN
IF NOT msf_curve_check(cv\surface_curve.
associated_geometry[i]) THEN
RETURN (FALSE);
END_IF;
END_IF;
END_IF;
END_REPEAT;
RETURN (TRUE);
END_IF;
ELSE
IF 'INTEGRATED_CNC_SCHEMA.POLYLINE' IN TYPEOF(cv) THEN
IF SIZEOF(cv\polyline.points) >= 3 THEN
RETURN (TRUE);
END_IF;
END_IF;
END_IF;
END_IF;
END_IF;
END_IF;
END_IF;
RETURN (FALSE);
END_FUNCTION; -- 10303-509: aic_manifold_surface

FUNCTION msf_surface_check (
surf : surface
) : BOOLEAN;
IF 'INTEGRATED_CNC_SCHEMA.ELEMENTARY_SURFACE' IN TYPEOF(surf) THEN
RETURN (TRUE);
ELSE
IF 'INTEGRATED_CNC_SCHEMA.SWEPT_SURFACE' IN TYPEOF(surf) THEN
RETURN (msf_curve_check(surf\swept_surface.swept_curve));
ELSE

```

```

IF ('INTEGRATED_CNC_SCHEMA.OFFSET_SURFACE' IN TYPEOF(surf)) AND (
  surf\offset_surface.self_intersect = FALSE) OR (surf\
  offset_surface.self_intersect = UNKNOWN) THEN
  RETURN (msf_surface_check(surf\offset_surface.basis_surface));
ELSE
  IF 'INTEGRATED_CNC_SCHEMA.SURFACE_REPLICA' IN TYPEOF(surf) THEN
    RETURN (msf_surface_check(surf\surface_replica.parent_surface))
    ;
  ELSE
    IF ('INTEGRATED_CNC_SCHEMA.B_SPLINE_SURFACE' IN TYPEOF(surf))
      AND (surf\b_spline_surface.self_intersect = FALSE) OR (surf\
      b_spline_surface.self_intersect = UNKNOWN) THEN
      RETURN (TRUE);
    END_IF;
  END_IF;
END_IF;
END_IF;
END_IF;
RETURN (FALSE);
END_FUNCTION; -- 10303-509: aic_manifold_surface

```

```

FUNCTION nmsf_curve_check (
  cv : representation_item
) : BOOLEAN;
IF SIZEOF([ 'INTEGRATED_CNC_SCHEMA.BOUNDED_CURVE',
  'INTEGRATED_CNC_SCHEMA.CONIC', 'INTEGRATED_CNC_SCHEMA.CURVE_REPLICA',
  'INTEGRATED_CNC_SCHEMA.LINE',
  'INTEGRATED_CNC_SCHEMA.OFFSET_CURVE_3D' ] * TYPEOF(cv)) > 1 THEN
  RETURN (FALSE);
ELSE
  IF ('INTEGRATED_CNC_SCHEMA.B_SPLINE_CURVE' IN TYPEOF(cv)) AND (cv\
  b_spline_curve.self_intersect = FALSE) OR (cv\b_spline_curve.
  self_intersect = UNKNOWN) THEN
    RETURN (TRUE);
  ELSE
    IF SIZEOF([ 'INTEGRATED_CNC_SCHEMA.CONIC',
      'INTEGRATED_CNC_SCHEMA.LINE' ] * TYPEOF(cv)) = 1 THEN
      RETURN (TRUE);
    ELSE
      IF 'INTEGRATED_CNC_SCHEMA.CURVE_REPLICA' IN TYPEOF(cv) THEN
        RETURN (nmsf_curve_check(cv\curve_replica.parent_curve));
      ELSE
        IF (('INTEGRATED_CNC_SCHEMA.OFFSET_CURVE_3D' IN TYPEOF(cv)) AND
          ((cv\offset_curve_3d.self_intersect = FALSE) OR (cv\
          offset_curve_3d.self_intersect = UNKNOWN))) AND NOT (
          'INTEGRATED_CNC_SCHEMA.POLYLINE' IN TYPEOF(cv\offset_curve_3d
          .basis_curve)) THEN
            RETURN (nmsf_curve_check(cv\offset_curve_3d.basis_curve));
          ELSE
            IF 'INTEGRATED_CNC_SCHEMA.PCURVE' IN TYPEOF(cv) THEN
              RETURN (nmsf_curve_check(cv\pcurve.reference_to_curve\
              representation.items[1]) AND nmsf_surface_check(cv\pcurve
              .basis_surface));
            ELSE

```



```

    );
ELSE
  IF ('INTEGRATED_CNC_SCHEMA.B_SPLINE_SURFACE' IN TYPEOF(surf))
    AND (surf\b_spline_surface.self_intersect = FALSE) OR (surf\
    b_spline_surface.self_intersect = UNKNOWN) THEN
    RETURN (TRUE);
  END_IF;
END_IF;
END_IF;
END_IF;
END_IF;
RETURN (FALSE);
END_FUNCTION; -- 10303-508: aic_non_manifold_surface

```

```

FUNCTION normalise (
  arg : vector_or_direction
) : vector_or_direction;
LOCAL
  ndim : INTEGER;
  v : direction;
  result : vector_or_direction;
  vec : vector;
  mag : REAL;
END_LOCAL;
IF NOT EXISTS(arg) THEN
  result := ?;
ELSE
  ndim := arg.dim;
  IF 'INTEGRATED_CNC_SCHEMA.VECTOR' IN TYPEOF(arg) THEN
    BEGIN
      v := dummy_gri || direction(arg.orientation.direction_ratios);
      IF arg.magnitude = 0.0 THEN
        RETURN (?);
      ELSE
        vec := dummy_gri || vector(v, 1.0);
      END_IF;
    END;
  ELSE
    v := dummy_gri || direction(arg.direction_ratios);
  END_IF;
  mag := 0.0;
  REPEAT i := 1 TO ndim;
    mag := mag + v.direction_ratios[i] * v.direction_ratios[i];
  END_REPEAT;
  IF mag > 0.0 THEN
    mag := sqrt(mag);
    REPEAT i := 1 TO ndim;
      v.direction_ratios[i] := v.direction_ratios[i] / mag;
    END_REPEAT;
    IF 'INTEGRATED_CNC_SCHEMA.VECTOR' IN TYPEOF(arg) THEN
      vec.orientation := v;
      result := vec;
    ELSE
      result := v;
    END_IF;
  END_IF;
END_IF;

```

```

        END_IF;
    ELSE
        RETURN (?);
    END_IF;
END_IF;
RETURN (result);
END_FUNCTION; -- 10303-42: geometry_schema

FUNCTION open_shell_reversed (
    a_shell : open_shell
) : oriented_open_shell;
LOCAL
    the_reverse : oriented_open_shell;
END_LOCAL;
IF 'INTEGRATED_CNC_SCHEMA.ORIENTED_OPEN_SHELL' IN TYPEOF(a_shell) THEN
    the_reverse := dummy_tri || connected_face_set(a_shell\
        connected_face_set.cfs_faces) || open_shell() ||
        oriented_open_shell(a_shell\oriented_open_shell.open_shell_element,
            NOT a_shell\oriented_open_shell.orientation);
ELSE
    the_reverse := dummy_tri || connected_face_set(a_shell\
        connected_face_set.cfs_faces) || open_shell() ||
        oriented_open_shell(a_shell, FALSE);
END_IF;
RETURN (the_reverse);
END_FUNCTION; -- 10303-42: topology_schema

FUNCTION orthogonal_complement (
    vec : direction
) : direction;
LOCAL
    result : direction;
END_LOCAL;
IF (vec.dim <> 2) OR NOT EXISTS(vec) THEN
    RETURN (?);
ELSE
    result := dummy_gri || direction([ -vec.direction_ratios[2], vec.
        direction_ratios[1] ]);
    RETURN (result);
END_IF;
END_FUNCTION; -- 10303-42: geometry_schema

FUNCTION path_head_to_tail (
    a_path : path
) : LOGICAL;
LOCAL
    n : INTEGER;
    p : LOGICAL := TRUE;
END_LOCAL;
n := SIZEOF(a_path.edge_list);
REPEAT i := 2 TO n;
    p := p AND (a_path.edge_list[(i - 1)].edge_end :=: a_path.edge_list[i
        ].edge_start);
END_REPEAT;

```

ISO 10303-238:2007(E)

```

RETURN (p);
END_FUNCTION; -- 10303-42: topology_schema

FUNCTION path_reversed (
  a_path : path
) : oriented_path;
LOCAL
  the_reverse : oriented_path;
END_LOCAL;
IF 'INTEGRATED_CNC_SCHEMA.ORIENTED_PATH' IN TYPEOF(a_path) THEN
  the_reverse := dummy_tri || path(list_of_topology_reversed(a_path.
    edge_list)) || oriented_path(a_path\oriented_path.path_element, NOT
    a_path\oriented_path.orientation);
ELSE
  the_reverse := dummy_tri || path(list_of_topology_reversed(a_path.
    edge_list)) || oriented_path(a_path, FALSE);
END_IF;
RETURN (the_reverse);
END_FUNCTION; -- 10303-42: topology_schema

FUNCTION scalar_times_vector (
  scalar : REAL;
  vec    : vector_or_direction
) : vector;
LOCAL
  v : direction;
  mag : REAL;
  result : vector;
END_LOCAL;
IF NOT EXISTS(scalar) OR NOT EXISTS(vec) THEN
  RETURN (?);
ELSE
  IF 'INTEGRATED_CNC_SCHEMA.VECTOR' IN TYPEOF(vec) THEN
    v := dummy_gri || direction(vec.orientation.direction_ratios);
    mag := scalar * vec.magnitude;
  ELSE
    v := dummy_gri || direction(vec.direction_ratios);
    mag := scalar;
  END_IF;
  IF mag < 0.0 THEN
    REPEAT i := 1 TO SIZEOF(v.direction_ratios);
      v.direction_ratios[i] := -v.direction_ratios[i];
    END_REPEAT;
    mag := -mag;
  END_IF;
  result := dummy_gri || vector(normalise(v), mag);
END_IF;
RETURN (result);
END_FUNCTION; -- 10303-42: geometry_schema

FUNCTION second_proj_axis (
  z_axis : direction;
  x_axis : direction;
  arg    : direction

```



```

    ) : direction;
LOCAL
    y_axis : vector;
    v : direction;
    temp : vector;
END_LOCAL;
IF NOT EXISTS(arg) THEN
    v := dummy_gri || direction([ 0.0, 1.0, 0.0 ]);
ELSE
    v := arg;
END_IF;
temp := scalar_times_vector(dot_product(v, z_axis), z_axis);
y_axis := vector_difference(v, temp);
temp := scalar_times_vector(dot_product(v, x_axis), x_axis);
y_axis := vector_difference(y_axis, temp);
y_axis := normalise(y_axis);
RETURN (y_axis.orientation);
END_FUNCTION; -- 10303-42: geometry_schema

FUNCTION set_of_topology_reversed (
    a_set : set_of_reversible_topology_item
) : set_of_reversible_topology_item;
LOCAL
    the_reverse : set_of_reversible_topology_item;
END_LOCAL;
the_reverse := [];
REPEAT i := 1 TO SIZEOF(a_set);
    the_reverse := the_reverse + topology_reversed(a_set[i]);
END_REPEAT;
RETURN (the_reverse);
END_FUNCTION; -- 10303-42: topology_schema

FUNCTION shell_reversed (
    a_shell : shell
) : shell;
IF 'INTEGRATED_CNC_SCHEMA.OPEN_SHELL' IN TYPEOF(a_shell) THEN
    RETURN (open_shell_reversed(a_shell));
ELSE
    IF 'INTEGRATED_CNC_SCHEMA.CLOSED_SHELL' IN TYPEOF(a_shell) THEN
        RETURN (closed_shell_reversed(a_shell));
    ELSE
        RETURN (?);
    END_IF;
END_IF;
END_FUNCTION; -- 10303-42: topology_schema

FUNCTION surface_weights_positive (
    b : rational_b_spline_surface
) : BOOLEAN;
LOCAL
    result : BOOLEAN := TRUE;
END_LOCAL;
REPEAT i := 0 TO b.u_upper;
    REPEAT j := 0 TO b.v_upper;

```

```

        IF b.weights[i][j] <= 0.0 THEN
            result := FALSE;
            RETURN (result);
        END_IF;
    END_REPEAT;
END_REPEAT;
RETURN (result);
END_FUNCTION; -- 10303-42: geometry_schema

FUNCTION topology_reversed (
    an_item : reversible_topology
) : reversible_topology;
IF 'INTEGRATED_CNC_SCHEMA.EDGE' IN TYPEOF(an_item) THEN
    RETURN (edge_reversed(an_item));
END_IF;
IF 'INTEGRATED_CNC_SCHEMA.PATH' IN TYPEOF(an_item) THEN
    RETURN (path_reversed(an_item));
END_IF;
IF 'INTEGRATED_CNC_SCHEMA.FACE_BOUND' IN TYPEOF(an_item) THEN
    RETURN (face_bound_reversed(an_item));
END_IF;
IF 'INTEGRATED_CNC_SCHEMA.FACE' IN TYPEOF(an_item) THEN
    RETURN (face_reversed(an_item));
END_IF;
IF 'INTEGRATED_CNC_SCHEMA.SHELL' IN TYPEOF(an_item) THEN
    RETURN (shell_reversed(an_item));
END_IF;
IF 'SET' IN TYPEOF(an_item) THEN
    RETURN (set_of_topology_reversed(an_item));
END_IF;
IF 'LIST' IN TYPEOF(an_item) THEN
    RETURN (list_of_topology_reversed(an_item));
END_IF;
RETURN (?);
END_FUNCTION; -- 10303-42: topology_schema

FUNCTION using_items (
    item          : founded_item_select;
    checked_items : SET OF founded_item_select
) : SET OF founded_item_select;
LOCAL
    new_check_items : SET OF founded_item_select;
    result_items    : SET OF founded_item_select;
    next_items      : SET OF founded_item_select;
END_LOCAL;
result_items := [];
new_check_items := checked_items + item;
next_items := QUERY (z <* bag_to_set(USEDIN(item, ''))| (
    'INTEGRATED_CNC_SCHEMA.REPRESENTATION_ITEM' IN TYPEOF(z)) OR (
    'INTEGRATED_CNC_SCHEMA.FOUNDED_ITEM' IN TYPEOF(z)));
IF SIZEOF(next_items) > 0 THEN
    REPEAT i := 1 TO HIINDEX(next_items);
        IF NOT (next_items[i] IN new_check_items) THEN
            result_items := result_items + next_items[i] + using_items(

```

```

        next_items[i], new_check_items);
    END_IF;
END_REPEAT;
END_IF;
RETURN (result_items);
END_FUNCTION; -- 10303-43: representation_schema

FUNCTION using_representations (
    item : founded_item_select
) : SET OF representation;
LOCAL
    results : SET OF representation;
    result_bag : BAG OF representation;
    intermediate_items : SET OF founded_item_select;
END_LOCAL;
results := [];
result_bag := USEDIN(item, 'INTEGRATED_CNC_SCHEMA.REPRESENTATION.ITEMS'
);
IF SIZEOF(result_bag) > 0 THEN
    REPEAT i := 1 TO HIINDEX(result_bag);
        results := results + result_bag[i];
    END_REPEAT;
END_IF;
intermediate_items := using_items(item, []);
IF SIZEOF(intermediate_items) > 0 THEN
    REPEAT i := 1 TO HIINDEX(intermediate_items);
        result_bag := USEDIN(intermediate_items[i],
            'INTEGRATED_CNC_SCHEMA.REPRESENTATION.ITEMS');
        IF SIZEOF(result_bag) > 0 THEN
            REPEAT j := 1 TO HIINDEX(result_bag);
                results := results + result_bag[j];
            END_REPEAT;
        END_IF;
    END_REPEAT;
END_IF;
RETURN (results);
END_FUNCTION; -- 10303-43: representation_schema

FUNCTION valid_calendar_date (
    date : calendar_date
) : LOGICAL;
CASE date.month_component OF
    1 :
        RETURN ((1 <= date.day_component) AND (date.day_component <= 31))
        ;
    2 :
        BEGIN
            IF leap_year(date.year_component) THEN
                RETURN ((1 <= date.day_component) AND (date.day_component <=
                    29));
            ELSE
                RETURN ((1 <= date.day_component) AND (date.day_component <=
                    28));
            END_IF;
        END;
END_CASE;

```

```

        END;
3 :
    RETURN ((1 <= date.day_component) AND (date.day_component <= 31))
    ;
4 :
    RETURN ((1 <= date.day_component) AND (date.day_component <= 30))
    ;
5 :
    RETURN ((1 <= date.day_component) AND (date.day_component <= 31))
    ;
6 :
    RETURN ((1 <= date.day_component) AND (date.day_component <= 30))
    ;
7 :
    RETURN ((1 <= date.day_component) AND (date.day_component <= 31))
    ;
8 :
    RETURN ((1 <= date.day_component) AND (date.day_component <= 31))
    ;
9 :
    RETURN ((1 <= date.day_component) AND (date.day_component <= 30))
    ;
10 :
    RETURN ((1 <= date.day_component) AND (date.day_component <= 31))
    ;
11 :
    RETURN ((1 <= date.day_component) AND (date.day_component <= 30))
    ;
12 :
    RETURN ((1 <= date.day_component) AND (date.day_component <= 31))
    ;
END_CASE;
RETURN (FALSE);
END_FUNCTION; -- 10303-41: date_time_schema

FUNCTION valid_geometrically_bounded_wf_curve (
    crv : curve
) : BOOLEAN;
IF SIZEOF([ 'INTEGRATED_CNC_SCHEMA.POLYLINE',
    'INTEGRATED_CNC_SCHEMA.B_SPLINE_CURVE',
    'INTEGRATED_CNC_SCHEMA.ELLIPSE', 'INTEGRATED_CNC_SCHEMA.CIRCLE' ] *
    TYPEOF(crv)) = 1 THEN
    RETURN (TRUE);
ELSE
    IF 'INTEGRATED_CNC_SCHEMA.TRIMMED_CURVE' IN TYPEOF(crv) THEN
        IF SIZEOF([ 'INTEGRATED_CNC_SCHEMA.LINE',
            'INTEGRATED_CNC_SCHEMA.PARABOLA',
            'INTEGRATED_CNC_SCHEMA.HYPERBOLA' ] * TYPEOF(crv\trimmed_curve.
                basis_curve)) = 1 THEN
            RETURN (TRUE);
        ELSE
            RETURN (valid_geometrically_bounded_wf_curve(crv\trimmed_curve.
                basis_curve));
        END_IF;
    END_IF;
END_FUNCTION;

```

```

ELSE
  IF 'INTEGRATED_CNC_SCHEMA.OFFSET_CURVE_3D' IN TYPEOF(crv) THEN
    RETURN (valid_geometrically_bounded_wf_curve(crv\offset_curve_3d.
      basis_curve));
  ELSE
    IF 'INTEGRATED_CNC_SCHEMA.CURVE_REPLICA' IN TYPEOF(crv) THEN
      RETURN (valid_geometrically_bounded_wf_curve(crv\curve_replica.
        parent_curve));
    ELSE
      IF 'INTEGRATED_CNC_SCHEMA.COMPOSITE_CURVE' IN TYPEOF(crv) THEN
        RETURN (SIZEOF(QUERY (ccs <* crv\composite_curve.segments|
          NOT valid_geometrically_bounded_wf_curve(ccs.parent_curve))
          ) = 0);
        END_IF;
      END_IF;
    END_IF;
  END_IF;
  RETURN (FALSE);
END_FUNCTION; -- 10303-510: aic_geometrically_bounded_wireframe

FUNCTION valid_geometrically_bounded_wf_point (
  pnt : point
) : BOOLEAN;
IF 'INTEGRATED_CNC_SCHEMA.CARTESIAN_POINT' IN TYPEOF(pnt) THEN
  RETURN (TRUE);
ELSE
  IF 'INTEGRATED_CNC_SCHEMA.POINT_ON_CURVE' IN TYPEOF(pnt) THEN
    RETURN (valid_geometrically_bounded_wf_curve(pnt\point_on_curve.
      basis_curve));
  ELSE
    IF 'INTEGRATED_CNC_SCHEMA.POINT_REPLICA' IN TYPEOF(pnt) THEN
      RETURN (valid_geometrically_bounded_wf_point(pnt\point_replica.
        parent_pt));
    END_IF;
  END_IF;
END_IF;
RETURN (FALSE);
END_FUNCTION; -- 10303-510: aic_geometrically_bounded_wireframe

FUNCTION valid_measure_value (
  m : measure_value
) : BOOLEAN;
IF 'REAL' IN TYPEOF(m) THEN
  RETURN (m > 0.0);
ELSE
  IF 'INTEGER' IN TYPEOF(m) THEN
    RETURN (m > 0);
  ELSE
    RETURN (TRUE);
  END_IF;
END_IF;
END_FUNCTION; -- 10303-43: representation_schema

```

```

FUNCTION valid_time (
    time : local_time
) : BOOLEAN;
IF EXISTS(time.second_component) THEN
    RETURN (EXISTS(time.minute_component));
ELSE
    RETURN (TRUE);
END_IF;
END_FUNCTION; -- 10303-41: date_time_schema

FUNCTION valid_units (
    m : measure_with_unit
) : BOOLEAN;
IF 'INTEGRATED_CNC_SCHEMA.LENGTH_MEASURE'
    IN TYPEOF(m.value_component) THEN
    IF derive_dimensional_exponents(m.unit_component) <>
        dimensional_exponents(1, 0, 0, 0, 0, 0, 0) THEN
        RETURN (FALSE);
    END_IF;
END_IF;
IF 'INTEGRATED_CNC_SCHEMA.TIME_MEASURE'
    IN TYPEOF(m.value_component) THEN
    IF derive_dimensional_exponents(m.unit_component) <>
        dimensional_exponents(0, 0, 1, 0, 0, 0, 0) THEN
        RETURN (FALSE);
    END_IF;
END_IF;
IF 'INTEGRATED_CNC_SCHEMA.PLANE_ANGLE_MEASURE'
    IN TYPEOF(m.value_component) THEN
    IF derive_dimensional_exponents(m.unit_component) <>
        dimensional_exponents(0, 0, 0, 0, 0, 0, 0) THEN
        RETURN (FALSE);
    END_IF;
END_IF;
IF 'INTEGRATED_CNC_SCHEMA.SOLID_ANGLE_MEASURE'
    IN TYPEOF(m.value_component) THEN
    IF derive_dimensional_exponents(m.unit_component) <>
        dimensional_exponents(0, 0, 0, 0, 0, 0, 0) THEN
        RETURN (FALSE);
    END_IF;
END_IF;
IF 'INTEGRATED_CNC_SCHEMA.RATIO_MEASURE'
    IN TYPEOF(m.value_component)
    THEN
    IF derive_dimensional_exponents(m.unit_component) <>
        dimensional_exponents(0, 0, 0, 0, 0, 0, 0) THEN
        RETURN (FALSE);
    END_IF;
END_IF;
IF 'INTEGRATED_CNC_SCHEMA.POSITIVE_LENGTH_MEASURE'
    IN TYPEOF(m.value_component) THEN
    IF derive_dimensional_exponents(m.unit_component) <>
        dimensional_exponents(1, 0, 0, 0, 0, 0, 0) THEN
        RETURN (FALSE);

```

```

    END_IF;
END_IF;
IF 'INTEGRATED_CNC_SCHEMA.POSITIVE_PLANE_ANGLE_MEASURE'
    IN TYPEOF(m.value_component) THEN
    IF derive_dimensional_exponents(m.unit_component) <>
        dimensional_exponents(0, 0, 0, 0, 0, 0) THEN
        RETURN (FALSE);
    END_IF;
END_IF;
RETURN (TRUE);
END_FUNCTION; -- 10303-41: measure_schema

FUNCTION valid_wireframe_edge_curve (
    crv : curve
) : BOOLEAN;
IF SIZEOF([ 'INTEGRATED_CNC_SCHEMA.LINE', 'INTEGRATED_CNC_SCHEMA.CONIC'
    , 'INTEGRATED_CNC_SCHEMA.B_SPLINE_CURVE',
    'INTEGRATED_CNC_SCHEMA.POLYLINE' ] * TYPEOF(crv)) = 1 THEN
    RETURN (TRUE);
ELSE
    IF 'INTEGRATED_CNC_SCHEMA.CURVE_REPLICA' IN TYPEOF(crv) THEN
        RETURN (valid_wireframe_edge_curve(crv\curve_replica.parent_curve))
        ;
    ELSE
        IF 'INTEGRATED_CNC_SCHEMA.OFFSET_CURVE_3D' IN TYPEOF(crv) THEN
            RETURN (valid_wireframe_edge_curve(crv\offset_curve_3d.
                basis_curve));
        END_IF;
    END_IF;
END_IF;
RETURN (FALSE);
END_FUNCTION; -- 10303-502: aic_shell_based_wireframe

FUNCTION valid_wireframe_vertex_point (
    pnt : point
) : BOOLEAN;
IF 'INTEGRATED_CNC_SCHEMA.CARTESIAN_POINT' IN TYPEOF(pnt) THEN
    RETURN (TRUE);
ELSE
    IF 'INTEGRATED_CNC_SCHEMA.POINT_REPLICA' IN TYPEOF(pnt) THEN
        RETURN (valid_wireframe_vertex_point(pnt\point_replica.parent_pt));
    END_IF;
END_IF;
RETURN (FALSE);
END_FUNCTION; -- 10303-502: aic_shell_based_wireframe

FUNCTION vector_difference (
    arg1 : vector_or_direction;
    arg2 : vector_or_direction
) : vector;
LOCAL
    result : vector;
    res : direction;
    vec1 : direction;

```

```

    vec2 : direction;
    mag : REAL;
    mag1 : REAL;
    mag2 : REAL;
    ndim : INTEGER;
END_LOCAL;
IF (NOT EXISTS(arg1) OR NOT EXISTS(arg2)) OR (arg1.dim <> arg2.dim)
    THEN
        RETURN (?);
    ELSE
        BEGIN
            IF 'INTEGRATED_CNC_SCHEMA.VECTOR' IN TYPEOF(arg1) THEN
                mag1 := arg1.magnitude;
                vec1 := arg1.orientation;
            ELSE
                mag1 := 1.0;
                vec1 := arg1;
            END_IF;
            IF 'INTEGRATED_CNC_SCHEMA.VECTOR' IN TYPEOF(arg2) THEN
                mag2 := arg2.magnitude;
                vec2 := arg2.orientation;
            ELSE
                mag2 := 1.0;
                vec2 := arg2;
            END_IF;
            vec1 := normalise(vec1);
            vec2 := normalise(vec2);
            ndim := SIZEOF(vec1.direction_ratios);
            mag := 0.0;
            res := dummy_gri || direction(vec1.direction_ratios);
            REPEAT i := 1 TO ndim;
                res.direction_ratios[i] := mag1 * vec1.direction_ratios[i] + mag2
                    * vec2.direction_ratios[i];
                mag := mag + res.direction_ratios[i] * res.direction_ratios[i];
            END_REPEAT;
            IF mag > 0.0 THEN
                result := dummy_gri || vector(res, sqrt(mag));
            ELSE
                result := dummy_gri || vector(vec1, 0.0);
            END_IF;
        END;
    END_IF;
RETURN (result);
END_FUNCTION; -- 10303-42: geometry_schema

FUNCTION verify_angle_measure_action_property (
    cad :      characterized_action_definition;
    prop_name : STRING
): LOGICAL;

RETURN (verify_rep_item_for_action_property(cad, prop_name,
    ['INTEGRATED_CNC_SCHEMA.MEASURE_REPRESENTATION_ITEM',
    'INTEGRATED_CNC_SCHEMA.PLANE_ANGLE_MEASURE_WITH_UNIT']));
END_FUNCTION; -- 10303-238: integrated_cnc_schema

```



```

FUNCTION verify_angle_measure_rep_item (
    rep :          representation;
    prop_name : STRING
): LOGICAL;

    RETURN (0 = SIZEOF (QUERY ( it <* rep.items |
        (it.name = prop_name) AND NOT (SIZEOF([
            'INTEGRATED_CNC_SCHEMA.MEASURE_REPRESENTATION_ITEM',
            'INTEGRATED_CNC_SCHEMA.PLANE_ANGLE_MEASURE_WITH_UNIT'] *
            TYPEOF(it)) = 2)))));
END_FUNCTION; -- 10303-238: integrated_cnc_schema

FUNCTION verify_angle_measure_resource_property (
    crd :          characterized_resource_definition;
    prop_name : STRING
): LOGICAL;

    RETURN (verify_rep_item_for_resource_property (crd, prop_name,
        ['INTEGRATED_CNC_SCHEMA.MEASURE_REPRESENTATION_ITEM',
        'INTEGRATED_CNC_SCHEMA.PLANE_ANGLE_MEASURE_WITH_UNIT']));
END_FUNCTION; -- 10303-238: integrated_cnc_schema

FUNCTION verify_angle_measure_tool_body_item (
    mt :          machining_tool;
    prop_name : STRING
): LOGICAL;

    RETURN (verify_rep_item_for_tool_body(mt, prop_name,
        ['INTEGRATED_CNC_SCHEMA.MEASURE_REPRESENTATION_ITEM',
        'INTEGRATED_CNC_SCHEMA.PLANE_ANGLE_MEASURE_WITH_UNIT']));
END_FUNCTION; -- 10303-238: integrated_cnc_schema

FUNCTION verify_ballnose_endmill_dimensions (
    mt :          machining_tool
): LOGICAL;

    LOCAL
        rads : SET OF REPRESENTATION_ITEM :=
            get_tool_body_item (mt, 'edge radius');
        dias : SET OF REPRESENTATION_ITEM :=
            get_tool_body_item (mt, 'effective cutting diameter');
    END_LOCAL;

    RETURN ((0 = SIZEOF(rads)) OR
        ((1 = SIZEOF(rads)) AND
            (1 = SIZEOF(dias)) AND
            (rads[1].value_component = dias[1].value_component/2))
    );
END_FUNCTION; -- 10303-238: integrated_cnc_schema

FUNCTION verify_bullnose_endmill_dimensions (
    mt :          machining_tool
): LOGICAL;

```

```

LOCAL
  rads : SET OF REPRESENTATION_ITEM :=
    get_tool_body_item (mt, 'edge radius');
  dias : SET OF REPRESENTATION_ITEM :=
    get_tool_body_item (mt, 'effective cutting diameter');
END_LOCAL;

RETURN ((1 = SIZEOF(rads)) AND
        (1 = SIZEOF(dias)) AND
        (rads[1].value_component < dias[1].value_component/2)
        );
END_FUNCTION; -- 10303-238: integrated_cnc_schema

FUNCTION verify_count_measure_action_property (
  cad :      characterized_action_definition;
  prop_name : STRING
): LOGICAL;

-- All properties have matching representations. The reason we test
-- for "nothing matching the negation" rather than "something matching
-- the positive" is so that we return true if there are no properties.
--
RETURN (0 = SIZEOF (QUERY (prop <* get_action_property (cad, prop_name) |

  -- property has no matching representations
  NOT (

    -- there is at least one rep with matching rep items
    (0 < SIZEOF (QUERY (prep <* USEDIN (prop, 'INTEGRATED_CNC_SCHEMA.' +
      'ACTION_PROPERTY_REPRESENTATION.PROPERTY') |

      -- property representation has at least one matching rep item
      (0 < SIZEOF (QUERY (it <* prep.representation.items |
        (('INTEGRATED_CNC_SCHEMA.MEASURE_REPRESENTATION_ITEM'
          IN TYPEOF(it)) AND
          ('INTEGRATED_CNC_SCHEMA.COUNT_MEASURE'
          IN TYPEOF(it.value_component))))
        )))
      )))
    )));
END_FUNCTION; -- 10303-238: integrated_cnc_schema

FUNCTION verify_count_measure_rep_item (
  rep :      representation;
  prop_name : STRING
): LOGICAL;

RETURN (0 = SIZEOF (QUERY ( it <* rep.items |
  (it.name = prop_name) AND NOT
  (('INTEGRATED_CNC_SCHEMA.MEASURE_REPRESENTATION_ITEM'
    IN TYPEOF(it)) AND
  ('INTEGRATED_CNC_SCHEMA.COUNT_MEASURE'
    IN TYPEOF(it.value_component))))));

```

```

END_FUNCTION; -- 10303-238: integrated_cnc_schema

FUNCTION verify_count_measure_resource_property (
  crd :      characterized_resource_definition;
  prop_name : STRING
): LOGICAL;

-- All properties have matching representations. The reason we test
-- for "nothing matching the negation" rather than "something matching
-- the positive" is so that we return true if there are no properties.
--
RETURN (0 = SIZEOF (QUERY (prop <* get_resource_property (crd, prop_name) |

  -- property has no matching representations
  NOT (

    -- there is at least one rep with matching rep items
    (0 < SIZEOF (QUERY (prep <* USEDIN (prop, 'INTEGRATED_CNC_SCHEMA.' +
      'RESOURCE_PROPERTY_REPRESENTATION.PROPERTY') |

      -- property representation has at least one matching rep item
      (0 < SIZEOF (QUERY (it <* prep.representation.items |
        (('INTEGRATED_CNC_SCHEMA.MEASURE_REPRESENTATION_ITEM'
          IN TYPEOF(it)) AND
          ('INTEGRATED_CNC_SCHEMA.COUNT_MEASURE'
            IN TYPEOF(it.value_component)))
        )))
      )))
    )));
END_FUNCTION; -- 10303-238: integrated_cnc_schema

FUNCTION verify_count_measure_tool_body_item (
  mt :      machining_tool;
  prop_name : STRING
): LOGICAL;

RETURN (0 = SIZEOF (QUERY (it <* get_tool_body_item (mt, prop_name) | NOT
  (('INTEGRATED_CNC_SCHEMA.MEASURE_REPRESENTATION_ITEM'
    IN TYPEOF(it)) AND
  ('INTEGRATED_CNC_SCHEMA.COUNT_MEASURE'
    IN TYPEOF(it.value_component)))
  ));
END_FUNCTION; -- 10303-238: integrated_cnc_schema

FUNCTION verify_descriptive_action_property (
  cad :      characterized_action_definition;
  prop_name : STRING
): LOGICAL;

RETURN (verify_rep_item_for_action_property(cad, prop_name,
  ['INTEGRATED_CNC_SCHEMA.DESCRPTIVE_REPRESENTATION_ITEM']));
END_FUNCTION; -- 10303-238: integrated_cnc_schema

FUNCTION verify_enumeration_action_property (

```

```

cad :          characterized_action_definition;
prop_name :   STRING;
prop_values  : SET OF STRING
): LOGICAL;

-- Each action property has at least one representation that contains
-- a descriptive rep item, and that descriptive rep item has a value
-- drawn from the prop_values set.

-- there are no properties that do not have matching representations
RETURN (0 = SIZEOF (QUERY (prop <* get_action_property (cad, prop_name) |

    NOT (
      -- there is at least one rep with matching rep items
      (0 < SIZEOF (QUERY (prep <* USEDIN (prop, 'INTEGRATED_CNC_SCHEMA.' +
        'ACTION_PROPERTY_REPRESENTATION.PROPERTY') |

          -- property representation has at least one matching rep item
          (0 < SIZEOF (QUERY (it <* prep.representation.items |
            (('INTEGRATED_CNC_SCHEMA.DESRIPTIVE_REPRESENTATION_ITEM'
              IN TYPEOF(it)) AND
              (it.description IN prop_values))
            )))
          )))
    ));
END_FUNCTION; -- 10303-238: integrated_cnc_schema

FUNCTION verify_enumeration_resource_property (
  crd :          characterized_resource_definition;
  prop_name :   STRING;
  prop_values  : SET OF STRING
): LOGICAL;

RETURN (0 = SIZEOF (QUERY (prop <* get_resource_property (crd, prop_name) |

    NOT (
      -- there is at least one rep with matching rep items
      (0 < SIZEOF (QUERY (prep <* USEDIN (prop, 'INTEGRATED_CNC_SCHEMA.' +
        'RESOURCE_PROPERTY_REPRESENTATION.PROPERTY') |

          -- property representation has at least one matching rep item
          (0 < SIZEOF (QUERY (it <* prep.representation.items |
            (('INTEGRATED_CNC_SCHEMA.DESRIPTIVE_REPRESENTATION_ITEM'
              IN TYPEOF(it)) AND
              (it.description IN prop_values))
            )))
          )))
    ));
END_FUNCTION; -- 10303-238: integrated_cnc_schema

FUNCTION verify_enumeration_tool_body_item (
  mt :          machining_tool;
  prop_name :   STRING;
  prop_values  : SET OF STRING

```

```

): LOGICAL;

RETURN (0 = SIZEOF (QUERY (it <* get_tool_body_item (mt, prop_name) | NOT
    (('INTEGRATED_CNC_SCHEMA.DESRIPTIVE_REPRESENTATION_ITEM'
     IN TYPEOF(it)) AND
     (it.description IN prop_values))
    )));
END_FUNCTION; -- 10303-238: integrated_cnc_schema

FUNCTION verify_length_measure_action_property (
    cad :      characterized_action_definition;
    prop_name : STRING
): LOGICAL;

RETURN (verify_rep_item_for_action_property (cad, prop_name,
    ['INTEGRATED_CNC_SCHEMA.MEASURE_REPRESENTATION_ITEM',
     'INTEGRATED_CNC_SCHEMA.LENGTH_MEASURE_WITH_UNIT']));
END_FUNCTION; -- 10303-238: integrated_cnc_schema

FUNCTION verify_length_measure_rep_item (
    rep :      representation;
    prop_name : STRING
): LOGICAL;

RETURN (0 = SIZEOF (QUERY ( it <* rep.items |
    (it.name = prop_name) AND NOT (SIZEOF([
     'INTEGRATED_CNC_SCHEMA.MEASURE_REPRESENTATION_ITEM',
     'INTEGRATED_CNC_SCHEMA.LENGTH_MEASURE_WITH_UNIT'] *
     TYPEOF(it)) = 2))));
END_FUNCTION; -- 10303-238: integrated_cnc_schema

FUNCTION verify_length_measure_resource_property (
    crd :      characterized_resource_definition;
    prop_name : STRING
): LOGICAL;

RETURN (verify_rep_item_for_resource_property (crd, prop_name,
    ['INTEGRATED_CNC_SCHEMA.MEASURE_REPRESENTATION_ITEM',
     'INTEGRATED_CNC_SCHEMA.LENGTH_MEASURE_WITH_UNIT']));
END_FUNCTION; -- 10303-238: integrated_cnc_schema

FUNCTION verify_length_measure_tool_body_item (
    mt :      machining_tool;
    prop_name : STRING
): LOGICAL;

RETURN (verify_rep_item_for_tool_body(mt, prop_name,
    ['INTEGRATED_CNC_SCHEMA.MEASURE_REPRESENTATION_ITEM',
     'INTEGRATED_CNC_SCHEMA.LENGTH_MEASURE_WITH_UNIT']));
END_FUNCTION; -- 10303-238: integrated_cnc_schema

FUNCTION verify_linear_speed_measure_rep_item (
    rep :      representation;
    prop_name : STRING

```

```

): LOGICAL;

RETURN (0 = SIZEOF (QUERY ( it <* rep.items |
    (it.name = prop_name) AND NOT
    (('INTEGRATED_CNC_SCHEMA.MEASURE_REPRESENTATION_ITEM'
    IN TYPEOF(it)) AND
    ('INTEGRATED_CNC_SCHEMA.NUMERIC_MEASURE'
    IN TYPEOF(it.value_component))))));
END_FUNCTION; -- 10303-238: integrated_cnc_schema

FUNCTION verify_numeric_measure_action_property (
    cad :      characterized_action_definition;
    prop_name : STRING
): LOGICAL;

-- All properties have matching representations. The reason we test
-- for "nothing matching the negation" rather than "something matching
-- the positive" is so that we return true if there are no properties.
--
RETURN (0 = SIZEOF (QUERY (prop <* get_action_property (cad, prop_name) |

    -- property has no matching representations
    NOT (

        -- there is at least one rep with matching rep items
        (0 < SIZEOF (QUERY (prep <* USEDIN (prop, 'INTEGRATED_CNC_SCHEMA.' +
            'ACTION_PROPERTY_REPRESENTATION.PROPERTY') |

            -- property representation has at least one matching rep item
            (0 < SIZEOF (QUERY (it <* prep.representation.items |
                (('INTEGRATED_CNC_SCHEMA.MEASURE_REPRESENTATION_ITEM'
                IN TYPEOF(it)) AND
                ('INTEGRATED_CNC_SCHEMA.NUMERIC_MEASURE'
                IN TYPEOF(it.value_component))))
            )))
        )))
    )));
END_FUNCTION; -- 10303-238: integrated_cnc_schema

FUNCTION verify_optional_action_property (
    cad :      characterized_action_definition;
    prop_name : STRING
): LOGICAL;

RETURN (1 >= SIZEOF (get_action_property (cad, prop_name)));
END_FUNCTION; -- 10303-238: integrated_cnc_schema

FUNCTION verify_optional_in_process_geometry (
    mpe : machining_process_executable
): LOGICAL;

RETURN
    ((verify_optional_action_property (mpe, 'as-is shape')) AND
    (verify_optional_action_property (mpe, 'to-be shape')) AND

```

```

(verify_optional_action_property (mpe, 'removal shape')) AND

-- All properties need advanced prep shape reps
(0 = SIZEOF (QUERY (prop < *
  USEDIN (mpe, 'INTEGRATED_CNC_SCHEMA.ACTION_PROPERTY.DEFINITION') |
  ((prop.name IN ['as-is shape', 'to-be shape', 'removal shape']) AND
  (0 = SIZEOF (QUERY (prep < * USEDIN (prop, 'INTEGRATED_CNC_SCHEMA.' +
    'ACTION_PROPERTY_REPRESENTATION.PROPERTY') |
    ('INTEGRATED_CNC_SCHEMA.SHAPE_REPRESENTATION'
    IN TYPEOF (prep.representation))))))
)))
);
END_FUNCTION; -- 10303-238: integrated_cnc_schema

FUNCTION verify_optional_relating_amr (
  am :          action_method;
  amr_types : SET OF STRING
): LOGICAL;

  RETURN (1 >= get_count_of_relating_amr (am, amr_types));
END_FUNCTION; -- 10303-238: integrated_cnc_schema

FUNCTION verify_optional_relating_amr_with_name (
  am :          action_method;
  amr_name :   STRING;
  amr_types : SET OF STRING
): LOGICAL;

  RETURN (1 >= get_count_of_relating_amr_with_name (
    am, amr_name, amr_types));
END_FUNCTION; -- 10303-238: integrated_cnc_schema

FUNCTION verify_optional_rep_item (
  rep :          representation;
  prop_name :   STRING
): LOGICAL;

  RETURN (1 >= SIZEOF (QUERY ( it < * rep.items |
    (it.name = prop_name))));
END_FUNCTION; -- 10303-238: integrated_cnc_schema

FUNCTION verify_optional_resource_property (
  crd :          characterized_resource_definition;
  prop_name :   STRING
): LOGICAL;

  RETURN (1 >= SIZEOF (get_resource_property (crd, prop_name)));
END_FUNCTION; -- 10303-238: integrated_cnc_schema

FUNCTION verify_optional_tool_body_item (
  mt :          machining_tool;
  prop_name :   STRING
): LOGICAL;

```

ISO 10303-238:2007(E)

```

    RETURN (1 >= SIZEOF (get_tool_body_item (mt, prop_name)));
END_FUNCTION; -- 10303-238: integrated_cnc_schema

FUNCTION verify_pressure_measure_action_property (
    cad :      characterized_action_definition;
    prop_name : STRING
): LOGICAL;

    RETURN (verify_numeric_measure_action_property (cad, prop_name));
END_FUNCTION; -- 10303-238: integrated_cnc_schema

FUNCTION verify_ratio_measure_action_property (
    cad :      characterized_action_definition;
    prop_name : STRING
): LOGICAL;

    RETURN (verify_rep_item_for_action_property (cad, prop_name,
        ['INTEGRATED_CNC_SCHEMA.MEASURE_REPRESENTATION_ITEM',
        'INTEGRATED_CNC_SCHEMA.RATIO_MEASURE_WITH_UNIT']));
END_FUNCTION; -- 10303-238: integrated_cnc_schema

FUNCTION verify_ratio_measure_rep_item (
    rep :      representation;
    prop_name : STRING
): LOGICAL;

    RETURN (0 = SIZEOF (QUERY ( it <* rep.items |
        (it.name = prop_name) AND NOT (SIZEOF([
        'INTEGRATED_CNC_SCHEMA.MEASURE_REPRESENTATION_ITEM',
        'INTEGRATED_CNC_SCHEMA.RATIO_MEASURE_WITH_UNIT'] *
        TYPEOF(it)) = 2))));
END_FUNCTION; -- 10303-238: integrated_cnc_schema

FUNCTION verify_related_type_for_amr (
    am :      action_method;
    amr_types : SET OF STRING;
    types :   SET OF STRING
): LOGICAL;

    RETURN (0 = SIZEOF (QUERY (amr <* get_relating_amr (am) |
        (SIZEOF(amr_types * TYPEOF(amr)) =
        SIZEOF(amr_types)) AND
        NOT
        (SIZEOF(types * TYPEOF(amr.related_method)) =
        SIZEOF(types)) ))));
END_FUNCTION; -- 10303-238: integrated_cnc_schema

FUNCTION verify_related_type_for_amr_with_name (
    am :      action_method;
    amr_name : STRING;
    amr_types : SET OF STRING;
    types :   SET OF STRING
): LOGICAL;

```



```

RETURN (0 = SIZEOF (QUERY (amr <* get_relating_amr (am) |
    (amr.name = amr_name) AND
    (SIZEOF(amr_types * TYPEOF(amr)) =
    SIZEOF(amr_types)) AND
    NOT
    (SIZEOF(types * TYPEOF(amr.related_method)) =
    SIZEOF(types) ) ));
END_FUNCTION; -- 10303-238: integrated_cnc_schema

FUNCTION verify_rep_item_for_action_property (
    cad :          characterized_action_definition;
    prop_name :    STRING;
    rep_item_types : SET OF STRING
): LOGICAL;

-- All properties have matching representations. The reason we test
-- for "nothing matching the negation" rather than "something matching
-- the positive" is so that we return true if there are no properties.
--
RETURN (0 = SIZEOF (QUERY (prop <* get_action_property (cad, prop_name) |

    -- property has no matching representations
    NOT (

        -- there is at least one rep with matching rep items
        (0 < SIZEOF (QUERY (prep <* USEDIN (prop, 'INTEGRATED_CNC_SCHEMA.' +
            'ACTION_PROPERTY_REPRESENTATION.PROPERTY') |

            -- property representation has at least one matching rep item
            (0 < SIZEOF (QUERY (it <* prep.representation.items |
                (SIZEOF (rep_item_types * TYPEOF(it)) =
                SIZEOF (rep_item_types))))
            )))
        )))
    )))
END_FUNCTION; -- 10303-238: integrated_cnc_schema

FUNCTION verify_rep_item_for_resource_property (
    crd :          characterized_resource_definition;
    prop_name :    STRING;
    rep_item_types : SET OF STRING
): LOGICAL;

RETURN (0 = SIZEOF (QUERY (prop <* get_resource_property (crd, prop_name) |
    NOT (0 < SIZEOF (QUERY (prep <* USEDIN (prop, 'INTEGRATED_CNC_SCHEMA.' +
        'RESOURCE_PROPERTY_REPRESENTATION.PROPERTY') |

        (0 < SIZEOF (QUERY (it <* prep.representation.items |
            (SIZEOF (rep_item_types * TYPEOF(it)) =
            SIZEOF (rep_item_types))))
        )))
    )))
END_FUNCTION; -- 10303-238: integrated_cnc_schema

```

ISO 10303-238:2007(E)

```

FUNCTION verify_rep_item_for_tool_body (
    mt :          machining_tool;
    prop_name :   STRING;
    rep_item_types : SET OF STRING
): LOGICAL;

    RETURN (0 = SIZEOF (QUERY (it <* get_tool_body_item (mt, prop_name) | NOT
        ((SIZEOF (rep_item_types * TYPEOF(it)) =
            SIZEOF (rep_item_types)))
        )));
END_FUNCTION; -- 10303-238: integrated_cnc_schema

FUNCTION verify_rep_name_for_action_property (
    cad :          characterized_action_definition;
    prop_name :   STRING;
    desc_names :  SET OF STRING
): LOGICAL;

    RETURN (0 = SIZEOF (QUERY (prop <*
        get_action_property (cad, prop_name) | NOT
        (0 < SIZEOF (QUERY (prep <* USEDIN (prop, 'INTEGRATED_CNC_SCHEMA.'+
            'ACTION_PROPERTY_REPRESENTATION.PROPERTY') |
            (prep.representation.name IN desc_names)
            )))
        )));
END_FUNCTION; -- 10303-238: integrated_cnc_schema

FUNCTION verify_rep_type_for_action_property (
    cad :          characterized_action_definition;
    prop_name :   STRING;
    rep_types :   SET OF STRING
): LOGICAL;

    RETURN (0 = SIZEOF (QUERY (prop <*
        get_action_property (cad, prop_name) | NOT
        (0 < SIZEOF (QUERY (prep <* USEDIN (prop, 'INTEGRATED_CNC_SCHEMA.'+
            'ACTION_PROPERTY_REPRESENTATION.PROPERTY') |
            (SIZEOF(rep_types * TYPEOF(preparepresentation)) =
                SIZEOF(rep_types))
            )))
        )));
END_FUNCTION; -- 10303-238: integrated_cnc_schema

FUNCTION verify_rep_type_for_resource_property (
    crd :          characterized_resource_definition;
    prop_name :   STRING;
    rep_types :   SET OF STRING
): LOGICAL;

    RETURN (0 = SIZEOF (QUERY (prop <*
        get_resource_property (crd, prop_name) | NOT
        (0 < SIZEOF (QUERY (prep <* USEDIN (prop, 'INTEGRATED_CNC_SCHEMA.'+
            'RESOURCE_PROPERTY_REPRESENTATION.PROPERTY') |

```

```

        (SIZEOF(rep_types * TYPEOF(preparepresentation)) =
        SIZEOF(rep_types))
    )))
END_FUNCTION; -- 10303-238: integrated_cnc_schema

FUNCTION verify_required_action_property (
    cad :      characterized_action_definition;
    prop_name : STRING
): LOGICAL;

    RETURN (1 = SIZEOF (get_action_property (cad, prop_name)));
END_FUNCTION; -- 10303-238: integrated_cnc_schema

FUNCTION verify_required_relating_amr (
    am :      action_method;
    amr_types : SET OF STRING
): LOGICAL;

    RETURN (1 = get_count_of_relating_amr (am, amr_types));
END_FUNCTION; -- 10303-238: integrated_cnc_schema

FUNCTION verify_required_relating_amr_with_name (
    am :      action_method;
    amr_name : STRING;
    amr_types : SET OF STRING
): LOGICAL;

    RETURN (1 = get_count_of_relating_amr_with_name (
        am, amr_name, amr_types));
END_FUNCTION; -- 10303-238: integrated_cnc_schema

FUNCTION verify_required_rep_item (
    rep :      representation;
    prop_name : STRING
): LOGICAL;

    RETURN (1 = SIZEOF (QUERY ( it <* rep.items |
        (it.name = prop_name))));
END_FUNCTION; -- 10303-238: integrated_cnc_schema

FUNCTION verify_required_resource_property (
    crd :      characterized_resource_definition;
    prop_name : STRING
): LOGICAL;

    RETURN (1 = SIZEOF (get_resource_property (crd, prop_name)));
END_FUNCTION; -- 10303-238: integrated_cnc_schema

FUNCTION verify_required_tool_body_item (
    mt :      machining_tool;
    prop_name : STRING
): LOGICAL;

```

ISO 10303-238:2007(E)

```

    RETURN (1 = SIZEOF (get_tool_body_item (mt, prop_name)));
END_FUNCTION; -- 10303-238: integrated_cnc_schema

FUNCTION verify_rotary_speed_measure_rep_item (
    rep :      representation;
    prop_name : STRING
): LOGICAL;

    RETURN (0 = SIZEOF (QUERY ( it <* rep.items |
        (it.name = prop_name) AND NOT
        (('INTEGRATED_CNC_SCHEMA.MEASURE_REPRESENTATION_ITEM'
            IN TYPEOF(it)) AND
        ('INTEGRATED_CNC_SCHEMA.NUMERIC_MEASURE'
            IN TYPEOF(it.value_component))))));
END_FUNCTION; -- 10303-238: integrated_cnc_schema

FUNCTION verify_time_measure_action_property (
    cad :      characterized_action_definition;
    prop_name : STRING
): LOGICAL;

    RETURN (verify_rep_item_for_action_property(cad, prop_name,
        ['INTEGRATED_CNC_SCHEMA.MEASURE_REPRESENTATION_ITEM',
        'INTEGRATED_CNC_SCHEMA.TIME_MEASURE_WITH_UNIT']));
END_FUNCTION; -- 10303-238: integrated_cnc_schema

FUNCTION verify_time_measure_rep_item (
    rep :      representation;
    prop_name : STRING
): LOGICAL;

    RETURN (0 = SIZEOF (QUERY ( it <* rep.items |
        (it.name = prop_name) AND NOT (SIZEOF([
        'INTEGRATED_CNC_SCHEMA.MEASURE_REPRESENTATION_ITEM',
        'INTEGRATED_CNC_SCHEMA.TIME_MEASURE_WITH_UNIT'] *
        TYPEOF(it)) = 2))));
END_FUNCTION; -- 10303-238: integrated_cnc_schema

FUNCTION verify_time_measure_resource_property (
    crd :      characterized_resource_definition;
    prop_name : STRING
): LOGICAL;

    RETURN (verify_rep_item_for_resource_property (crd, prop_name,
        ['INTEGRATED_CNC_SCHEMA.MEASURE_REPRESENTATION_ITEM',
        'INTEGRATED_CNC_SCHEMA.TIME_MEASURE_WITH_UNIT']));
END_FUNCTION; -- 10303-238: integrated_cnc_schema

END_SCHEMA; -- integrated_cnc_schema

```

**Annex B**  
(normative)

**AIM short names**

Table B.1 provides the short names of entities specified in the AIM of this part of ISO 10303. Requirements on the use of the short names are found in the implementation methods included in ISO 10303.

**Table B.1 — AIM short names of entities**

Entity name	Short name
ACTION	ACTION
ACTION_METHOD	ACTMTH
ACTION_METHOD_RELATIONSHIP	ACMTRL
ACTION_METHOD_WITH_ASSOCIATED_DOCUMENTS	AMWAD
ACTION_PROPERTY	ACTPRP
ACTION_PROPERTY_REPRESENTATION	ACPRRP
ACTION_RELATIONSHIP	ACTRLT
ACTION_RESOURCE	ACTRSR
ACTION_RESOURCE_RELATIONSHIP	ACRSRL
ACTION_RESOURCE_REQUIREMENT	ACRSRQ
ACTION_RESOURCE_REQUIREMENT_RELATIONSHIP	ARRR
ACTION_RESOURCE_TYPE	ACRSTY
ADDRESS	ADDRSS
ADVANCED_BREP_SHAPE_REPRESENTATION	ABSR
ADVANCED_FACE	ADVFC
AND_EXPRESSION	ANDEXP
ANGULAR_LOCATION	ANGLCT
ANGULAR_SIZE	ANGSZ
ANGULARITY_TOLERANCE	ANGTLR
APEX	APEX
APPLICATION_CONTEXT	APPCNT
APPLICATION_CONTEXT_ELEMENT	APCNEL

**Table B.1 — AIM short names of entities (continued)**

Entity name	Short name
APPLICATION_PROTOCOL_DEFINITION	APPRDF
APPLIED_APPROVAL_ASSIGNMENT	APAPAS
APPLIED_AREA	APPAR
APPLIED_CLASSIFICATION_ASSIGNMENT	APCLAS
APPLIED_DATE_AND_TIME_ASSIGNMENT	ADATA
APPLIED_DATE_ASSIGNMENT	APDTAS
APPLIED_DOCUMENT_REFERENCE	APDCRF
APPLIED_DOCUMENT_USAGE_CONSTRAINT_ASSIGNMENT	ADUCA
APPLIED_EXTERNAL_IDENTIFICATION_ASSIGNMENT	AEIA
APPLIED_IDENTIFICATION_ASSIGNMENT	APIDAS
APPLIED_ORGANIZATION_ASSIGNMENT	APORAS
APPLIED_PERSON_AND_ORGANIZATION_ASSIGNMENT	APAOA
APPLIED_SECURITY_CLASSIFICATION_ASSIGNMENT	ASCA
APPROVAL	APPRVL
APPROVAL_ASSIGNMENT	APPASS
APPROVAL_DATE_TIME	APDTTM
APPROVAL_PERSON_ORGANIZATION	APPROR
APPROVAL_RELATIONSHIP	APPRLT
APPROVAL_ROLE	APPRL
APPROVAL_STATUS	APPSTT
ASSEMBLY_COMPONENT_USAGE	ASCMUS
AXIS1_PLACEMENT	AX1PLC
AXIS2_PLACEMENT_2D	A2PL2D
AXIS2_PLACEMENT_3D	A2PL3D
B_SPLINE_CURVE	BSPCR
B_SPLINE_CURVE_WITH_KNOTS	BSCWK
B_SPLINE_SURFACE	BSPSR
B_SPLINE_SURFACE_WITH_KNOTS	BSSWK

**Table B.1 — AIM short names of entities (continued)**

Entity name	Short name
BACK_BORING_OPERATION	BCBROP
BEZIER_CURVE	BZRCRV
BEZIER_SURFACE	BZRSRF
BINARY_BOOLEAN_EXPRESSION	BNBLEX
BINARY_GENERIC_EXPRESSION	BNGNEX
BLOCK	BLOCK
BLOCK_SHAPE_REPRESENTATION	BLSHRP
BOOLEAN_EXPRESSION	BLNEXP
BORING_OPERATION	BRNOPR
BOSS	BOSS
BOSS_TOP	BSSTP
BOTTOM_AND_SIDE_MILLING_OPERATION	BASMO
BOUNDARY_CURVE	BNDCR
BOUNDED_CURVE	BNDCRV
BOUNDED_PCURVE	BNDPCR
BOUNDED_SURFACE	BNDSRF
BOUNDED_SURFACE_CURVE	BNSRCR
BREP_WITH_VOIDS	BRWTVD
CALENDAR_DATE	CLNDT
CARTESIAN_POINT	C RTPNT
CARTESIAN_TRANSFORMATION_OPERATOR	CR TROP
CARTESIAN_TRANSFORMATION_OPERATOR_3D	CTO3
CENTRE_OF_SYMMETRY	CNOFSY
CHAMFER	CHMFR
CHAMFER_OFFSET	CHMOFF
CHARACTERIZED_OBJECT	CHROBJ
CIRCLE	CIRCLE
CIRCULAR_CLOSED_PROFILE	CRCLPR

**Table B.1 — AIM short names of entities (continued)**

Entity name	Short name
CIRCULAR_PATTERN	CRCPTT
CIRCULAR_RUNOUT_TOLERANCE	CRRNTL
CLASS	CLASS
CLASSIFICATION_ASSIGNMENT	CLSASS
CLASSIFICATION_ROLE	CLSRL
CLOSED_PATH_PROFILE	CLPTPR
CLOSED_SHELL	CLSSHL
COAXIALITY_TOLERANCE	CXLTLR
COMMON_DATUM	CMMDTM
COMPARISON_EQUAL	CMPEQL
COMPARISON_EXPRESSION	CMPEXP
COMPARISON_GREATER	CMPGRT
COMPARISON_GREATER_EQUAL	CMGREQ
COMPARISON_LESS	CMPLSS
COMPARISON_LESS_EQUAL	CMLSEQ
COMPARISON_NOT_EQUAL	CMNTEQ
COMPOSITE_CURVE	CMPCRIV
COMPOSITE_CURVE_ON_SURFACE	CCOS
COMPOSITE_CURVE_SEGMENT	CMCRSG
COMPOSITE_HOLE	CMPHL
COMPOSITE_SHAPE_ASPECT	CMSHAS
COMPOUND_FEATURE	CMPFTR
COMPOUND_REPRESENTATION_ITEM	CMRPIT
CONCENTRICITY_TOLERANCE	CNCTLR
CONCURRENT_ACTION_METHOD	CNACMT
CONIC	CONIC
CONICAL_SURFACE	CNCSRF
CONNECTED_EDGE_SET	CNEDST



**Table B.1 — AIM short names of entities (continued)**

Entity name	Short name
CONNECTED_FACE_SET	CNFCST
CONTEXT_DEPENDENT_SHAPE_REPRESENTATION	CDSR
CONTEXT_DEPENDENT_UNIT	CNDPUN
CONTOURING_TURNING_OPERATION	CNTROP
CONVERSION_BASED_UNIT	CNBSUN
COORDINATED_UNIVERSAL_TIME_OFFSET	CUTO
CURVE	CURVE
CURVE_BOUNDED_SURFACE	CRBNSR
CURVE_REPLICA	CRVRPL
CYLINDRICAL_SHAPE_REPRESENTATION	CYSHRP
CYLINDRICAL_SURFACE	CYLSRF
CYLINDRICITY_TOLERANCE	CYLTLR
DATA_ENVIRONMENT	DTENV
DATE	DATE
DATE_AND_TIME	DTANTM
DATE_AND_TIME_ASSIGNMENT	DATA
DATE_ASSIGNMENT	DTASS
DATE_ROLE	DTRL
DATE_TIME_ROLE	DTMRL
DATUM	DATUM
DATUM_FEATURE	DTMFTR
DATUM_REFERENCE	DTMRFR
DATUM_TARGET	DTMTRG
DEFINITIONAL_REPRESENTATION	DFNRPR
DEGENERATE_PCURVE	DGNPCR
DEGENERATE_TOROIDAL_SURFACE	DGTRSR
DERIVED_SHAPE_ASPECT	DRSHAS
DERIVED_UNIT	DRVUNT

**Table B.1 — AIM short names of entities (continued)**

Entity name	Short name
DERIVED_UNIT_ELEMENT	DRUNEL
DESCRIPTION_ATTRIBUTE	DSCATT
DESCRIPTIVE_REPRESENTATION_ITEM	DSRPIT
DIMENSION_RELATED_TOLERANCE_ZONE_ELEMENT	DRTZE
DIMENSIONAL_CHARACTERISTIC_REPRESENTATION	DMCHRP
DIMENSIONAL_EXPONENTS	DMNEXP
DIMENSIONAL_LOCATION	DMNLCT
DIMENSIONAL_LOCATION_WITH_PATH	DLWP
DIMENSIONAL_SIZE	DMNSZ
DIMENSIONAL_SIZE_WITH_PATH	DSWP
DIRECTED_DIMENSIONAL_LOCATION	DRDMLC
DIRECTION	DRCTN
DIRECTION_SHAPE_REPRESENTATION	DRSHRP
DOCUMENT	DCMNT
DOCUMENT_FILE	DCMFL
DOCUMENT_REFERENCE	DCMRFR
DOCUMENT_REPRESENTATION_TYPE	DCRPTY
DOCUMENT_TYPE	DCMTYP
DOCUMENT_USAGE_CONSTRAINT	DCUSCN
DOCUMENT_USAGE_CONSTRAINT_ASSIGNMENT	DUCA
DOCUMENT_USAGE_ROLE	DCUSRL
DOCUMENT_WITH_CLASS	DCWTCL
DRILLING_OPERATION	DRLOPR
DRILLING_TYPE_OPERATION	DRTYOP
DRILLING_TYPE_STRATEGY	DRTYST
EDGE	EDGE
EDGE_BASED_WIREFRAME_MODEL	EBWM
EDGE_BASED_WIREFRAME_SHAPE_REPRESENTATION	EBWSR

**Table B.1 — AIM short names of entities (continued)**

Entity name	Short name
EDGE_CURVE	EDGCRV
EDGE_LOOP	EDGLP
EDGE_ROUND	EDGRND
ELEMENTARY_SURFACE	ELMSRF
ELLIPSE	ELLPS
ENVIRONMENT	ENVRNM
EVALUATED_DEGENERATE_PCURVE	EVDGPC
EXPANDED_UNCERTAINTY	EXPUNC
EXPRESSION	EXPRSS
EXPRESSION_REPRESENTATION_ITEM	EXPRPIT
EXTENSION	EXTNSN
EXTERNAL_IDENTIFICATION_ASSIGNMENT	EXIDAS
EXTERNAL_SOURCE	EXTSRC
EXTERNALLY_DEFINED_CLASS	EXD0
EXTERNALLY_DEFINED_DIMENSION_DEFINITION	EDDD
EXTERNALLY_DEFINED_FEATURE_DEFINITION	EDFD
EXTERNALLY_DEFINED_GENERAL_PROPERTY	EDGP
EXTERNALLY_DEFINED_ITEM	EXDFIT
EXTERNALLY_DEFINED_ITEM_RELATIONSHIP	EDIR
EXTERNALLY_DEFINED_REPRESENTATION_WITH_PARAMETERS	EDRWP
FACE	FACE
FACE_BASED_SURFACE_MODEL	FBSM
FACE_BOUND	FCBND
FACE_OUTER_BOUND	FCOTBN
FACE_SHAPE_REPRESENTATION	FCSHRP
FACE_SURFACE	FCSRF
FACETED_BREP	FCTBR
FACETED_BREP_SHAPE_REPRESENTATION	FBSR

**Table B.1 — AIM short names of entities (continued)**

Entity name	Short name
FACING_TURNING_OPERATION	FCTROP
FEATURE_COMPONENT_DEFINITION	FTCMDF
FEATURE_COMPONENT_RELATIONSHIP	FTCMRL
FEATURE_DEFINITION	FTRDFN
FEATURE_PATTERN	FTRPTT
FILLET	FILLET
FLAT_FACE	FLTFC
FLATNESS_TOLERANCE	FLTTLR
FOUNDED_ITEM	FNDITM
FREEFORM_MILLING_OPERATION	FRMLOP
FREEFORM_MILLING_STRATEGY	FRMLST
FREEFORM_MILLING_TOLERANCE_REPRESENTATION	FMTR
FUNCTIONALLY_DEFINED_TRANSFORMATION	FNDFTR
GEAR	GEAR
GENERAL_PROPERTY	GNRPRP
GENERAL_PROPERTY_ASSOCIATION	GNPRAS
GENERIC_EXPRESSION	GNREXP
GENERIC_LITERAL	GNRLTR
GENERIC_VARIABLE	GNRVRB
GEOMETRIC_ALIGNMENT	GMTALG
GEOMETRIC_CURVE_SET	GMCNST
GEOMETRIC_INTERSECTION	GMTINT
GEOMETRIC_REPRESENTATION_CONTEXT	GMRPCN
GEOMETRIC_REPRESENTATION_ITEM	GMRPIT
GEOMETRIC_SET	GMTST
GEOMETRIC_TOLERANCE	GMTTLR
GEOMETRIC_TOLERANCE_RELATIONSHIP	GMTLRL
GEOMETRIC_TOLERANCE_WITH_DATUM_REFERENCE	GTWDR

**Table B.1 — AIM short names of entities (continued)**

Entity name	Short name
GEOMETRIC_TOLERANCE_WITH_DEFINED_UNIT	GTWDU
GEOMETRICALLY_BOUNDED_SURFACE_SHAPE_REPRESENTATION	GBSSR
GEOMETRICALLY_BOUNDED_WIREFRAME_SHAPE_REPRESENTATION	GBWSR
GLOBAL_UNCERTAINTY_ASSIGNED_CONTEXT	GC
GLOBAL_UNIT_ASSIGNED_CONTEXT	GUAC
GROOVING_TURNING_OPERATION	GRTROP
GROUP	GROUP
HOLE_BOTTOM	HLBTT
HYPERBOLA	HYPRBL
ID_ATTRIBUTE	IDATT
IDENTIFICATION_ASSIGNMENT	IDNASS
IDENTIFICATION_ROLE	IDNRL
INSTANCED_FEATURE	INSFTR
INT_LITERAL	INTLTR
INT_NUMERIC_VARIABLE	INNMVR
INTERSECTION_CURVE	INTCRV
ITEM_DEFINED_TRANSFORMATION	ITDFTR
KNOWN_SOURCE	KNWSRC
KNURLING_TURNING_OPERATION	KNTROP
LENGTH_MEASURE_WITH_UNIT	LMWU
LENGTH_UNIT	LNGUNT
LIMITS_AND_FITS	LMANFT
LINE	LINE
LINE_PROFILE_TOLERANCE	LNPO
LINEAR_PROFILE	LNRPRF
LITERAL_NUMBER	LTRNMB
LOCAL_TIME	LCLTM

**Table B.1 — AIM short names of entities (continued)**

Entity name	Short name
LOCATION_SHAPE_REPRESENTATION	LCSHRP
LOOP	LOOP
MACHINING_ADAPTIVE_CONTROL_RELATIONSHIP	MACR
MACHINING_APPROACH_RETRACT_STRATEGY	MARS
MACHINING_CUTTING_COMPONENT	MCCTCM
MACHINING_CUTTING_CORNER_REPRESENTATION	MCCR
MACHINING_DWELL_TIME_REPRESENTATION	MDTR
MACHINING_EXECUTION_RESOURCE	MCEXRS
MACHINING_FEATURE_PROCESS	MCFTPR
MACHINING_FEATURE_RELATIONSHIP	MCFTRL
MACHINING_FEATURE_SEQUENCE_RELATIONSHIP	MFSR
MACHINING_FEED_SPEED_REPRESENTATION	MFS0
MACHINING_FINAL_FEATURE_RELATIONSHIP	MFF0
MACHINING_FUNCTIONS	MCHFNC
MACHINING_FUNCTIONS_RELATIONSHIP	MCFNRL
MACHINING_NC_FUNCTION	MCNCFN
MACHINING_OFFSET_VECTOR_REPRESENTATION	MOVR
MACHINING_OPERATION	MCHOPR
MACHINING_OPERATION_RELATIONSHIP	MCOPRL
MACHINING_OPERATOR_INSTRUCTION	MCOPIN
MACHINING_OPERATOR_INSTRUCTION_RELATIONSHIP	MOI0
MACHINING_PROCESS_BODY_RELATIONSHIP	MPBR
MACHINING_PROCESS_BRANCH_RELATIONSHIP	MPB0
MACHINING_PROCESS_CONCURRENT_RELATIONSHIP	MPCR
MACHINING_PROCESS_EXECUTABLE	MCPREX
MACHINING_PROCESS_MODEL	MCPRMD
MACHINING_PROCESS_MODEL_RELATIONSHIP	MPMR
MACHINING_PROCESS_SEQUENCE_RELATIONSHIP	MPSR

**Table B.1 — AIM short names of entities (continued)**

Entity name	Short name
MACHINING_PROJECT	MCHPRJ
MACHINING_PROJECT_WORKPIECE_RELATIONSHIP	MPWR
MACHINING_RAPID_MOVEMENT	MCRPMV
MACHINING_SETUP	MCH1
MACHINING_SETUP_WORKPIECE_RELATIONSHIP	MSW0
MACHINING_SPINDLE_SPEED_REPRESENTATION	MSS0
MACHINING_STRATEGY	MCHSTR
MACHINING_STRATEGY_RELATIONSHIP	MCSTRL
MACHINING_TECHNOLOGY	MCHTCH
MACHINING_TECHNOLOGY_RELATIONSHIP	MCTCRL
MACHINING_TOOL	MCHTL
MACHINING_TOOL_BODY_REPRESENTATION	MTBR
MACHINING_TOOL_DIRECTION_REPRESENTATION	MTD0
MACHINING_TOOL_USAGE	MCTLUS
MACHINING_TOOLPATH	MCHTLP
MACHINING_TOOLPATH_SEQUENCE_RELATIONSHIP	MTSR
MACHINING_TOOLPATH_SPEED_PROFILE_REPRESENTATION	MTSPR
MACHINING_TOUCH_PROBING	MCTCPR
MACHINING_WORKINGSTEP	MCHWRK
MACHINING_WORKPLAN	MCH0
MAKE_FROM_USAGE_OPTION	MFUO
MANIFOLD_SOLID_BREP	MNSLBR
MANIFOLD_SURFACE_SHAPE_REPRESENTATION	MSSR
MAPPED_ITEM	MPPITM
MARKING	MRKNG
MASS_MEASURE_WITH_UNIT	MMWU
MASS_UNIT	MSSUNT
MATERIAL_DESIGNATION	MTRDSG

**Table B.1 — AIM short names of entities (continued)**

Entity name	Short name
MATERIAL_DESIGNATION_CHARACTERIZATION	MTDSCH
MATERIAL_PROPERTY	MTRPRP
MATERIAL_PROPERTY_REPRESENTATION	MTPRRP
MEASURE_QUALIFICATION	MSRQLF
MEASURE_REPRESENTATION_ITEM	MSRPIT
MEASURE_WITH_UNIT	MSWTUN
MILLING_TYPE_OPERATION	MLTYOP
MILLING_TYPE_STRATEGY	MLTYST
MODIFIED_GEOMETRIC_TOLERANCE	MDGMTL
MODIFIED_PATTERN	MDFPTT
MULTIPLE_ARITY_BOOLEAN_EXPRESSION	MABE
MULTIPLE_ARITY_GENERIC_EXPRESSION	MAGE
NAME_ATTRIBUTE	NMATT
NAMED_UNIT	NMDUNT
NEXT_ASSEMBLY_USAGE_OCCURRENCE	NAUO
NGON_CLOSED_PROFILE	NGCLPR
NGON_SHAPE_REPRESENTATION	NGSHRP
NON_MANIFOLD_SURFACE_SHAPE_REPRESENTATION	NMSSR
NOT_EXPRESSION	NTEXP
NUMERIC_EXPRESSION	NMREXP
NUMERIC_VARIABLE	NMRVRB
OBJECT_ROLE	OBJRL
OFFSET_CURVE_3D	OF3CR3D
OFFSET_SURFACE	OFFSRF
OPEN_PATH_PROFILE	OPPTPR
OPEN_SHELL	OPNSHL
OR_EXPRESSION	OREXP
ORDINAL_DATE	ORDDT



**Table B.1 — AIM short names of entities (continued)**

Entity name	Short name
ORGANIZATION	ORGNZT
ORGANIZATION_ASSIGNMENT	ORGASS
ORGANIZATION_ROLE	ORGRLE
ORGANIZATIONAL_ADDRESS	ORGADD
ORIENTED_CLOSED_SHELL	ORCLSH
ORIENTED_EDGE	ORNEDG
ORIENTED_FACE	ORNFC
ORIENTED_OPEN_SHELL	OROPSH
ORIENTED_PATH	ORNPTH
OUTER_BOUNDARY_CURVE	OTBNCR
OUTER_ROUND	OTRRND
OUTSIDE_PROFILE	OTSPRF
PARABOLA	PRBL
PARALLEL_OFFSET	PRLOFF
PARALLELISM_TOLERANCE	PRLTLR
PARAMETRIC_REPRESENTATION_CONTEXT	PRRPCN
PARTIAL_CIRCULAR_PROFILE	PRCRPR
PATH	PATH
PATH_FEATURE_COMPONENT	PTFTCM
PATH_SHAPE_REPRESENTATION	PTSHRP
PATTERN_OFFSET_MEMBERSHIP	PTOFMM
PATTERN_OMIT_MEMBERSHIP	PTOMMM
PCURVE	PCURVE
PERPENDICULAR_TO	PRPT
PERPENDICULARITY_TOLERANCE	PRPTLR
PERSON	PERSON
PERSON_AND_ORGANIZATION	PRANOR
PERSON_AND_ORGANIZATION_ASSIGNMENT	PAOA

**Table B.1 — AIM short names of entities (continued)**

Entity name	Short name
PERSON_AND_ORGANIZATION_ROLE	PAOR
PERSONAL_ADDRESS	PRSADD
PLACED_DATUM_TARGET_FEATURE	PDT0
PLACEMENT	PLCMNT
PLANAR_SHAPE_REPRESENTATION	PLSHRP
PLANE	PLANE
PLANE_ANGLE_MEASURE_WITH_UNIT	PAMWU
PLANE_ANGLE_UNIT	PLANUN
PLANE_MILLING_OPERATION	PLMLOP
PLUS_MINUS_TOLERANCE	PLMNTL
POCKET	POCKET
POCKET_BOTTOM	PCKBTT
POINT	POINT
POINT_ON_CURVE	PNONCR
POINT_ON_SURFACE	PNONSR
POINT_REPLICA	PNTRPL
POLY_LOOP	PLYLP
POLYLINE	PLYLN
POSITION_TOLERANCE	PSTTLR
PRE_DEFINED_ITEM	PRDFIT
PRECISION_QUALIFIER	PRCQLF
PROCESS_PRODUCT_ASSOCIATION	PRPRAS
PROCESS_PROPERTY_ASSOCIATION	PRPRS
PRODUCT	PRDCT
PRODUCT_CATEGORY	PRDCTG
PRODUCT_CATEGORY_RELATIONSHIP	PRCTRL
PRODUCT_CONTEXT	PRDCNT
PRODUCT_DEFINITION	PRDDFN

**Table B.1 — AIM short names of entities (continued)**

Entity name	Short name
PRODUCT_DEFINITION_CONTEXT	PRDFCN
PRODUCT_DEFINITION_FORMATION	PRDFFR
PRODUCT_DEFINITION_FORMATION_WITH_SPECIFIED_SOURCE	PDFWSS
PRODUCT_DEFINITION_PROCESS	PRDFPR
PRODUCT_DEFINITION_RELATIONSHIP	PRDFRL
PRODUCT_DEFINITION_SHAPE	PRDFSH
PRODUCT_DEFINITION_USAGE	PRDFUS
PRODUCT_DEFINITION_WITH_ASSOCIATED_DOCUMENTS	PDWAD
PRODUCT_RELATED_PRODUCT_CATEGORY	PRPC
PROFILE_FLOOR	PRFFLR
PROJECTED_ZONE_DEFINITION	PRZNDP
PROPERTY_DEFINITION	PRPDFN
PROPERTY_DEFINITION_REPRESENTATION	PRDFRP
PROPERTY_PROCESS	PRPPRC
PROTRUSION	PRTRSN
QUALIFIED_REPRESENTATION_ITEM	QLRPIT
QUALITATIVE_UNCERTAINTY	QLTUNC
QUASI_UNIFORM_CURVE	QSUNCR
QUASI_UNIFORM_SURFACE	QSUNSR
RATIO_MEASURE_WITH_UNIT	RMWU
RATIO_UNIT	RTUNT
RATIONAL_B_SPLINE_CURVE	RBSC
RATIONAL_B_SPLINE_SURFACE	RBSS
REAL_LITERAL	RLLTR
REAL_NUMERIC_VARIABLE	RLNMVR
RECTANGULAR_CLOSED_PROFILE	RCCLPR
RECTANGULAR_COMPOSITE_SURFACE	RCCMSR
RECTANGULAR_PATTERN	RCTPTT

**Table B.1 — AIM short names of entities (continued)**

Entity name	Short name
RECTANGULAR_TRIMMED_SURFACE	RCTRSR
REFERENCED_MODIFIED_DATUM	RFMDDT
REMOVAL_VOLUME	RMVVLM
REPARAMETRISED_COMPOSITE_CURVE_SEGMENT	RCCS
REPLICATE_FEATURE	RPLFTR
REPRESENTATION	RPRSNT
REPRESENTATION_CONTEXT	RPRCNT
REPRESENTATION_ITEM	RPRITM
REPRESENTATION_ITEM_RELATIONSHIP	RPITRL
REPRESENTATION_MAP	RPRMP
REPRESENTATION_RELATIONSHIP	RPRRLT
REPRESENTATION_RELATIONSHIP_WITH_TRANSFORMATION	RRWT
REQUIREMENT_FOR_ACTION_RESOURCE	RFAR
RESOURCE_PROPERTY	RSRPRP
RESOURCE_PROPERTY_REPRESENTATION	RSPRRP
RESOURCE_REQUIREMENT_TYPE	RSRQTY
REVOLVED_PROFILE	RVLPRF
RIB_TOP	RBTP
RIB_TOP_FLOOR	RBTPFL
RIGHT_CIRCULAR_CYLINDER	RGCRCY
ROLE_ASSOCIATION	RLASS
ROUND_HOLE	RNDHL
ROUNDED_END	RNDEND
ROUNDED_U_PROFILE	RNUPR
ROUNDNESS_TOLERANCE	RNDTLR
RUNOUT_ZONE_DEFINITION	RNZNDF
RUNOUT_ZONE_ORIENTATION	RNZNOR
RUNOUT_ZONE_ORIENTATION_REFERENCE_DIRECTION	RZORD

**Table B.1 — AIM short names of entities (continued)**

Entity name	Short name
SEAM_CURVE	SMCRV
SECURITY_CLASSIFICATION	SCRCLS
SECURITY_CLASSIFICATION_ASSIGNMENT	SCCLAS
SECURITY_CLASSIFICATION_LEVEL	SCCLLV
SEQUENTIAL_METHOD	SQNMTH
SERIAL_ACTION_METHOD	SRACMT
SHAPE_ASPECT	SHPASP
SHAPE_ASPECT_DERIVING_RELATIONSHIP	SADR
SHAPE_ASPECT_RELATIONSHIP	SHASRL
SHAPE_DEFINING_RELATIONSHIP	SHDFRL
SHAPE_DEFINITION_REPRESENTATION	SHDFRP
SHAPE_DIMENSION_REPRESENTATION	SHDMRP
SHAPE_REPRESENTATION	SHPRPR
SHAPE_REPRESENTATION_RELATIONSHIP	SHRPLR
SHAPE_REPRESENTATION_WITH_PARAMETERS	SRWP
SHELL_BASED_SURFACE_MODEL	SBSM
SHELL_BASED_WIREFRAME_MODEL	SBWM
SHELL_BASED_WIREFRAME_SHAPE_REPRESENTATION	SBWSR
SI_UNIT	SUNT
SIDE_MILLING_OPERATION	SDMLOP
SIMPLE_GENERIC_EXPRESSION	SMGNEX
SIMPLE_NUMERIC_EXPRESSION	SMNMEX
SLOT	SLOT
SLOT_END	SLTEND
SOLID_ANGLE_MEASURE_WITH_UNIT	SAMWU
SOLID_ANGLE_UNIT	SLANUN
SOLID_MODEL	SLDMDL
SPHERICAL_CAP	SPHCP

**Table B.1 — AIM short names of entities (continued)**

Entity name	Short name
SPHERICAL_SURFACE	SPHSRF
SQUARE_U_PROFILE	SQUPR
STANDARD_UNCERTAINTY	STNUNC
STEP	STEP
STRAIGHTNESS_TOLERANCE	STRTLR
SURFACE	SRFC
SURFACE_CURVE	SRFCRV
SURFACE_OF_LINEAR_EXTRUSION	SL
SURFACE_OF_REVOLUTION	SROFRV
SURFACE_PATCH	SRFPTC
SURFACE_PROFILE_TOLERANCE	SRPRTL
SURFACE_REPLICA	SRFRPL
SURFACE_TEXTURE_REPRESENTATION	SRTXRP
SWEPT_SURFACE	SWPSRF
SYMMETRIC_SHAPE_ASPECT	SYSHAS
SYMMETRY_TOLERANCE	SYMTLR
TANGENT	TNGNT
TAPER	TAPER
TAPPING_OPERATION	TPPOPR
TEE_PROFILE	TPRF
THREAD	THREAD
THREAD_RUNOUT	THRRNT
THREADING_TURNING_OPERATION	THTROP
TIME_MEASURE_WITH_UNIT	TMWU
TIME_UNIT	TMUNT
TOLERANCE_VALUE	TLRVL
TOLERANCE_ZONE	TLRZN
TOLERANCE_ZONE_DEFINITION	TLZNDF

**Table B.1 — AIM short names of entities (continued)**

Entity name	Short name
TOLERANCE_ZONE_FORM	TLZNFR
TOPOLOGICAL_REPRESENTATION_ITEM	TPRPIT
TOROIDAL_SURFACE	TRDSRF
TOTAL_RUNOUT_TOLERANCE	TTRNTL
TRANSITION_FEATURE	TRNFTR
TRIMMED_CURVE	TRMCRV
TURNED_KNURL	TRNKNR
TURNING_TYPE_OPERATION	TRTYOP
TURNING_TYPE_STRATEGY	TRTYST
TYPE_QUALIFIER	TYPQLF
UNARY_BOOLEAN_EXPRESSION	UNBLEX
UNARY_GENERIC_EXPRESSION	UNGNEX
UNCERTAINTY_MEASURE_WITH_UNIT	UMWU
UNCERTAINTY_QUALIFIER	UNCQLF
UNIFORM_CURVE	UNFCRV
UNIFORM_SURFACE	UNFSRF
VALUE_RANGE	VLRNG
VALUE_REPRESENTATION_ITEM	VLRPIT
VARIABLE	VRBL
VARIABLE_SEMANTICS	VRBSMN
VECTOR	VECTOR
VEE_PROFILE	VPRF
VERTEX	VERTEX
VERTEX_LOOP	VRTLP
VERTEX_POINT	VRTPNT
VERTEX_SHELL	VRTSHL
WEEK_OF_YEAR_AND_DAY_DATE	WOYADD
WIRE_SHELL	WRSHL

**Table B.1 — AIM short names of entities (continued)**

Entity name	Short name
XOR_EXPRESSION	XREXP



## Annex C (normative)

### Implementation method-specific requirements

The implementation method defines what types of exchange behaviour are required with respect to this part of ISO 10303. Conformance to this part of ISO 10303 shall be realized in an exchange structure described by either ISO 10303-21 or ISO 10303-28.

#### C.1 Requirements specific to ISO 10303-21

If the implementation method is ISO 10303-21, the file format shall be encoded according to the syntax and EXPRESS language mapping defined in ISO 10303-21 and in the AIM defined in Annex A of this part of ISO 10303. The header of the exchange structure shall identify use of this part of ISO 10303 by the schema name ‘integrated\_cnc\_schema’.

#### C.2 Requirements specific to ISO 10303-28

If the implementation method is ISO 10303-28, the file format shall be encoded according to the syntax and EXPRESS language mapping defined in ISO 10303-28 and in the AIM defined in Annex A of this part of ISO 10303. The ISO 10303-28 configuration shown below shall be used.

```
<?xml version="1.0"?>
<configuration
  xmlns="urn:oid:1.0.10303.28.2.1.2"
  xmlns:xs="http://www.w3.org/2001/XMLSchema">

  <schema targetNamespace="urn:oid:1.0.10303.238.1.0.1" />
  <option exp-attribute="attribute-content" tagless="true" />
  <uosElement name="iso_10303_28_terse" >
    <add_attribute name="schema" type="xs:NMTOKEN" usage="required" />
  </uosElement>
</configuration>
```

The iso\_10303\_28\_terse element shall identify the use of this part of ISO 10303 by the namespace ‘urn:oid:1.0.10303.238.1.0.1’ and the ‘schema’ attribute value of ‘integrated\_cnc\_schema’.

**EXAMPLE** The ISO 10303-28 configuration results in instance data written using the “attribute-content” encoding enclosed in the iso\_10303\_28\_terse UOS element, as shown in the fragment below.

```
<?xml version="1.0"?>
<iso_10303_28_terse
  xmlns="urn:oid:1.0.10303.238.1.0.1"
  xmlns:exp="urn:oid:1.0.10303.28.2.1.1"
  xmlns:xsi="http://www.w3.org/2001/XMLSchema-instance"
  schema="integrated_cnc_schema">
```

## ISO 10303-238:2007(E)

```
<exp:header>
  <exp:name>dataset</exp:name>
  <exp:preprocessor_version>stepnc writer</exp:preprocessor_version>
</exp:header>

<!-- instance data -->
<Axis2_placement_3d id="id1" Name="" Location="id2" Axis="id3" Ref_direction="id4"/>
<Cartesian_point id="id2" Name="loc" Coordinates="3.5 -3.5 -4.16875"/>
<Direction id="id3" Name="Z direction" Direction_ratios="0 0 1"/>
<Direction id="id4" Name="X direction" Direction_ratios="1 0 0"/>
</iso_10303_28_terse>
```

.....

## Annex D (normative)

### Protocol Implementation Conformance Statement (PICS) proforma

This clause lists the optional elements of this part of ISO 10303. An implementation may choose to support any combination of these optional elements. However, certain combinations of options are likely to be implemented together. These combinations are called conformance classes and are described in the subclauses of this annex.

This annex is in the form of a questionnaire. This questionnaire is intended to be filled out by the implementer and may be used in preparation for conformance testing by a testing laboratory. The completed PICS proforma is referred to as a PICS.

Question:

1. Please provide an identifier for the product or system for which conformance is claimed:

Product name and current version number: \_\_\_\_\_

2. Please indicate the implementation method chosen:

ISO 10303-21 exchange structure — preprocessor

Preprocessor name and current version number: \_\_\_\_\_

ISO 10303-21 exchange structure — postprocessor

Postprocessor name and current version number: \_\_\_\_\_

ISO 10303-28 XML exchange structure — preprocessor

Preprocessor name and current version number: \_\_\_\_\_

ISO 10303-28 XML exchange structure — postprocessor

Postprocessor name and current version number: \_\_\_\_\_

3. This part of ISO 10303 defines four conformance classes. Each class is defined so as to include all the options specified by the preceding class. Please indicate the highest numbered class for which conformance is claimed. Circle one:

CC1: Tool path programming

CC2: Closed-loop programming

CC3: Feature-based programming

CC4: Generative programming

4. If conformance to CC1: Tool path programming is claimed, answer the questions below.

(a) Indicate which machining technologies are supported. Circle all that apply:

milling  
turning

(b) Indicate which toolpath curve geometries are supported. Circle all that apply:

polylines, composite or trimmed curves based upon line or circle  
all bounded\_curve types  
the following bounded\_curve types: \_\_\_\_\_

5. If conformance to CC2: Closed-loop programming is claimed, answer the questions below.

(a) Indicate which machining technologies are supported. Circle all that apply:

milling  
turning

(b) Indicate which toolpath curve geometries are supported. Circle all that apply:

polylines, composite or trimmed curves based upon line or circle  
all bounded\_curve types  
the following bounded\_curve types: \_\_\_\_\_

(c) Indicate which workpiece shape representations are supported. Circle all that apply:

advanced\_brep\_shape\_representation  
edge\_based\_wireframe\_shape\_representation  
faceted\_brep\_shape\_representation  
geometrically\_bounded\_surface\_shape\_representation  
geometrically\_bounded\_wireframe\_shape\_representation  
manifold\_surface\_shape\_representation  
non\_manifold\_surface\_shape\_representation  
shell\_based\_wireframe\_shape\_representation

6. If conformance to CC3: Feature-based programming is claimed, answer the questions below.

(a) Indicate which machining technologies are supported. Circle all that apply:

milling using 2.5D features only  
milling using all features  
milling using the following features: \_\_\_\_\_  
turning using all features  
turning using the following features: \_\_\_\_\_

(b) Indicate which workpiece shape representations are supported. Circle all that apply:

advanced\_brep\_shape\_representation  
edge\_based\_wireframe\_shape\_representation

faceted\_brep\_shape\_representation  
 geometrically\_bounded\_surface\_shape\_representation  
 geometrically\_bounded\_wireframe\_shape\_representation  
 manifold\_surface\_shape\_representation  
 non\_manifold\_surface\_shape\_representation  
 shell\_based\_wireframe\_shape\_representation

7. If conformance to CC4: Generative programming is claimed, answer the questions below.

(a) Indicate which machining technologies are supported. Circle all that apply:

milling using 2.5D features only  
 milling using all features  
 milling using the following features: \_\_\_\_\_  
 turning using all features  
 turning using the following features: \_\_\_\_\_

(b) Indicate which workpiece shape representations are supported. Circle all that apply:

advanced\_brep\_shape\_representation  
 edge\_based\_wireframe\_shape\_representation  
 faceted\_brep\_shape\_representation  
 geometrically\_bounded\_surface\_shape\_representation  
 geometrically\_bounded\_wireframe\_shape\_representation  
 manifold\_surface\_shape\_representation  
 non\_manifold\_surface\_shape\_representation  
 shell\_based\_wireframe\_shape\_representation

## **Annex E** (normative)

### **Information object registration**

#### **E.1 Document identification**

In order to provide for unambiguous identification of an information object in an open system, the object identifier

{ iso standard 10303 part(238) version(1) }

is assigned to this part of ISO 10303. The meaning of this value is defined in ISO/IEC 8824-1, and is described in ISO 10303-1.

#### **E.2 Schema identification**

In order to provide for unambiguous identification of the `integrated_cnc_schema` in an open information system, the object identifiers are assigned as follows:

{ iso standard 10303 part(238) version(1) schema(1) integrated-cnc-schema(1) }

is assigned to the `integrated_cnc_schema` schema (see Annex A). The meaning of this value is defined in ISO/IEC 8824-1, and is described in ISO 10303-1.

**Annex F**  
(informative)

**Application activity model**

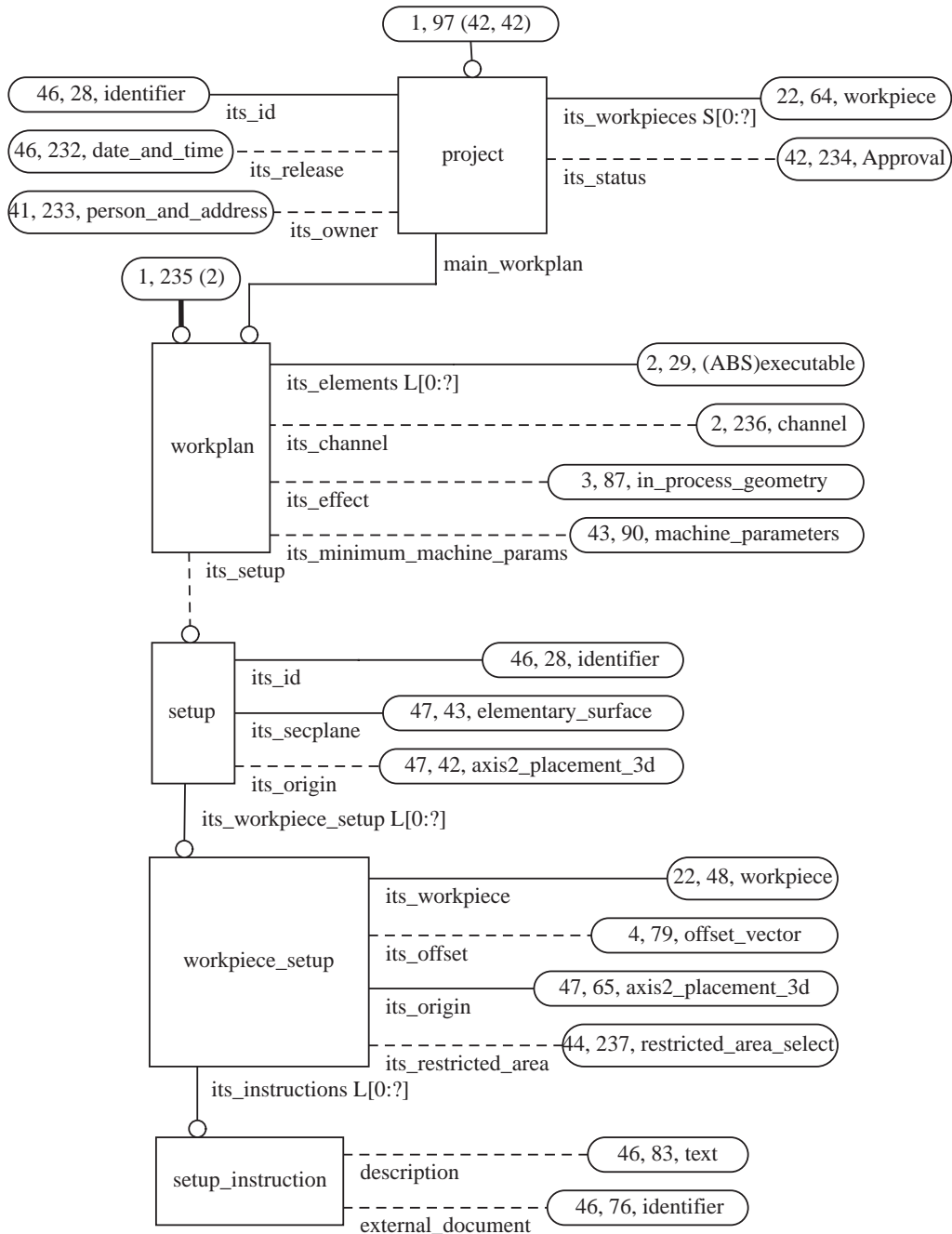
The application activity model (AAM) is provided as an aid to understanding the scope and information requirements defined in this application protocol. The application activity model is given in Annex B of ISO 14649-1:2003.

**Annex G**  
(informative)

**Application reference model**

This annex provides the application reference model for this part of ISO 10303. The application reference model is a graphical representation of the structure and constraints of the application objects specified in clause 4, including the application objects referenced from ISO 14649-10, ISO 14649-11, ISO 14649-12, ISO 14649-111 and ISO 14649-121. The graphical form of the application reference model is presented in EXPRESS-G. The application reference model is independent from any implementation method. EXPRESS-G is defined in Annex D of ISO 10303-11:1994.





**Figure G.1 — ARM diagram (1 of 48)**

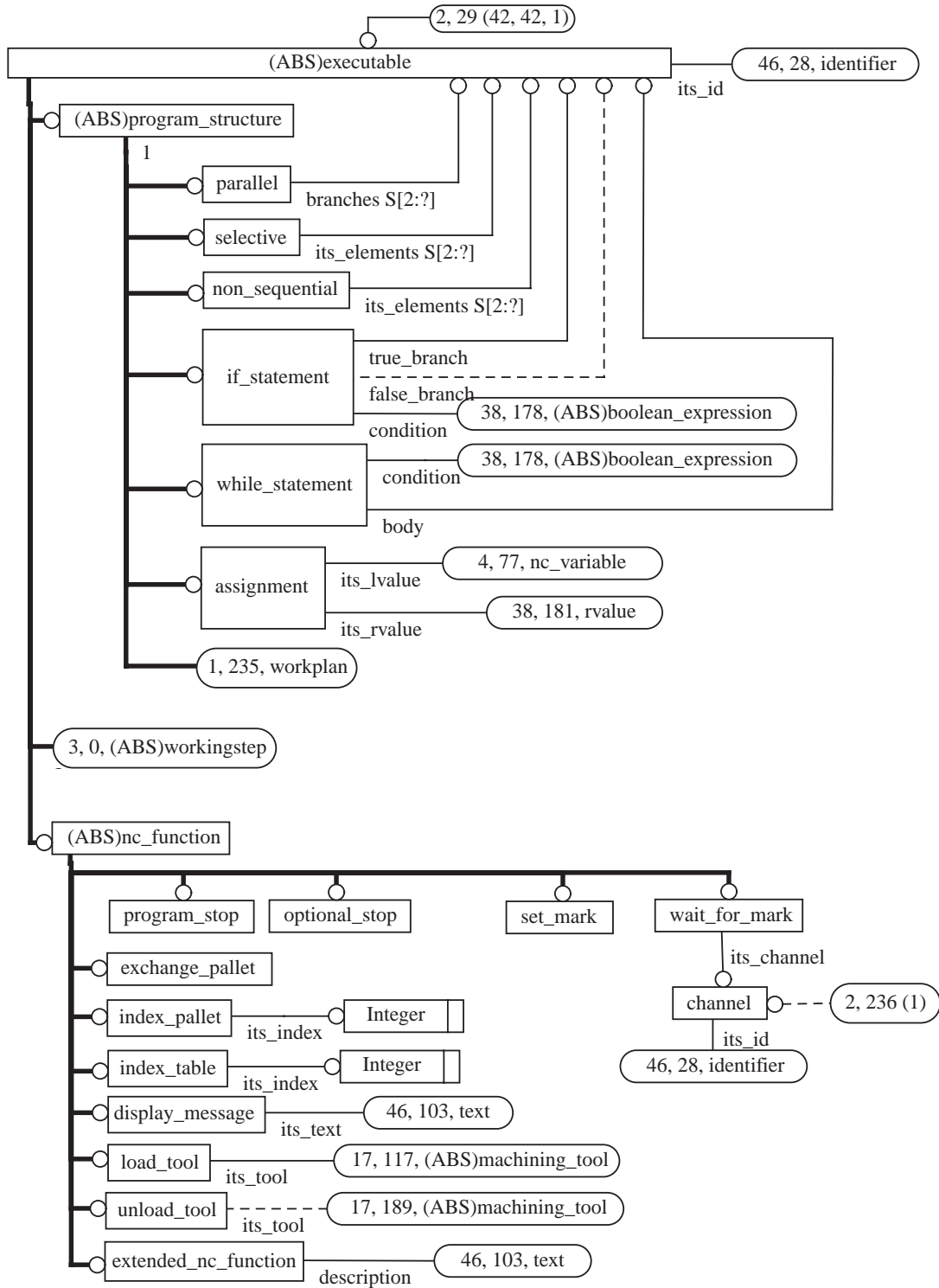
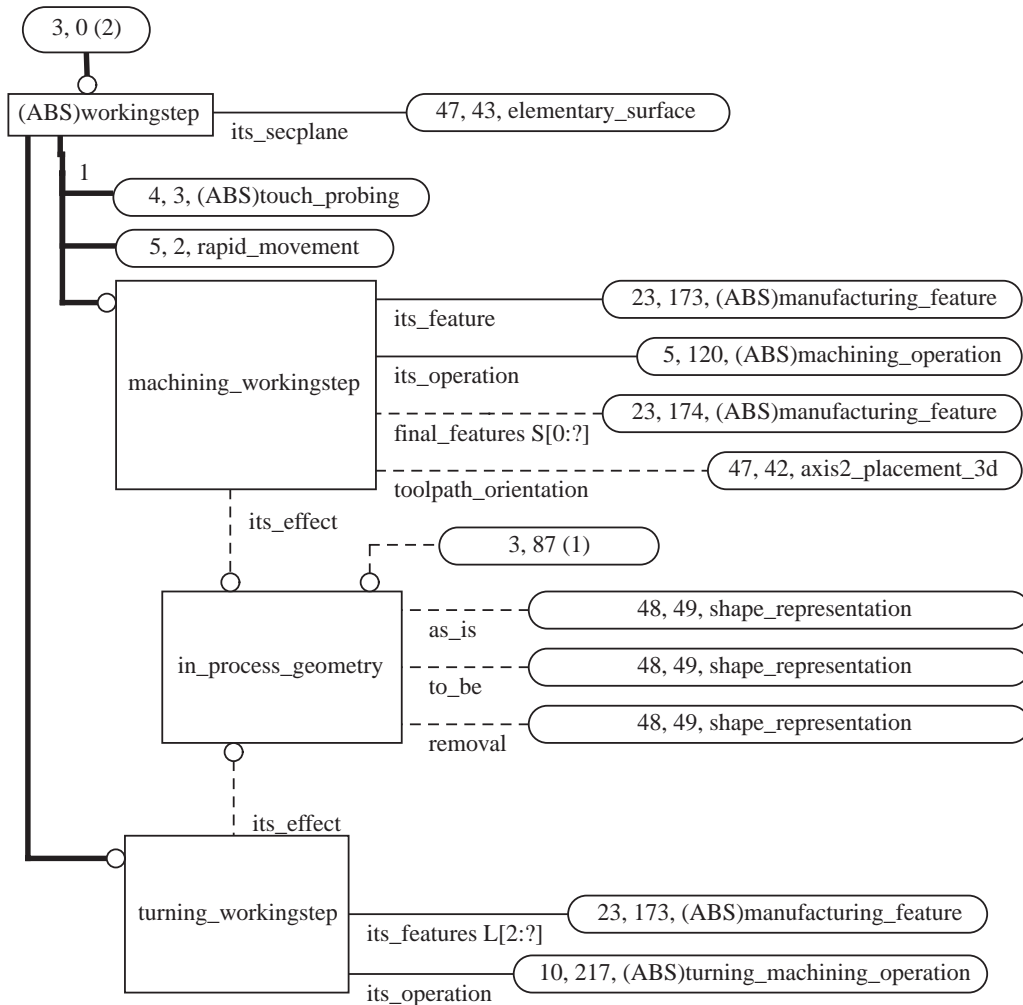
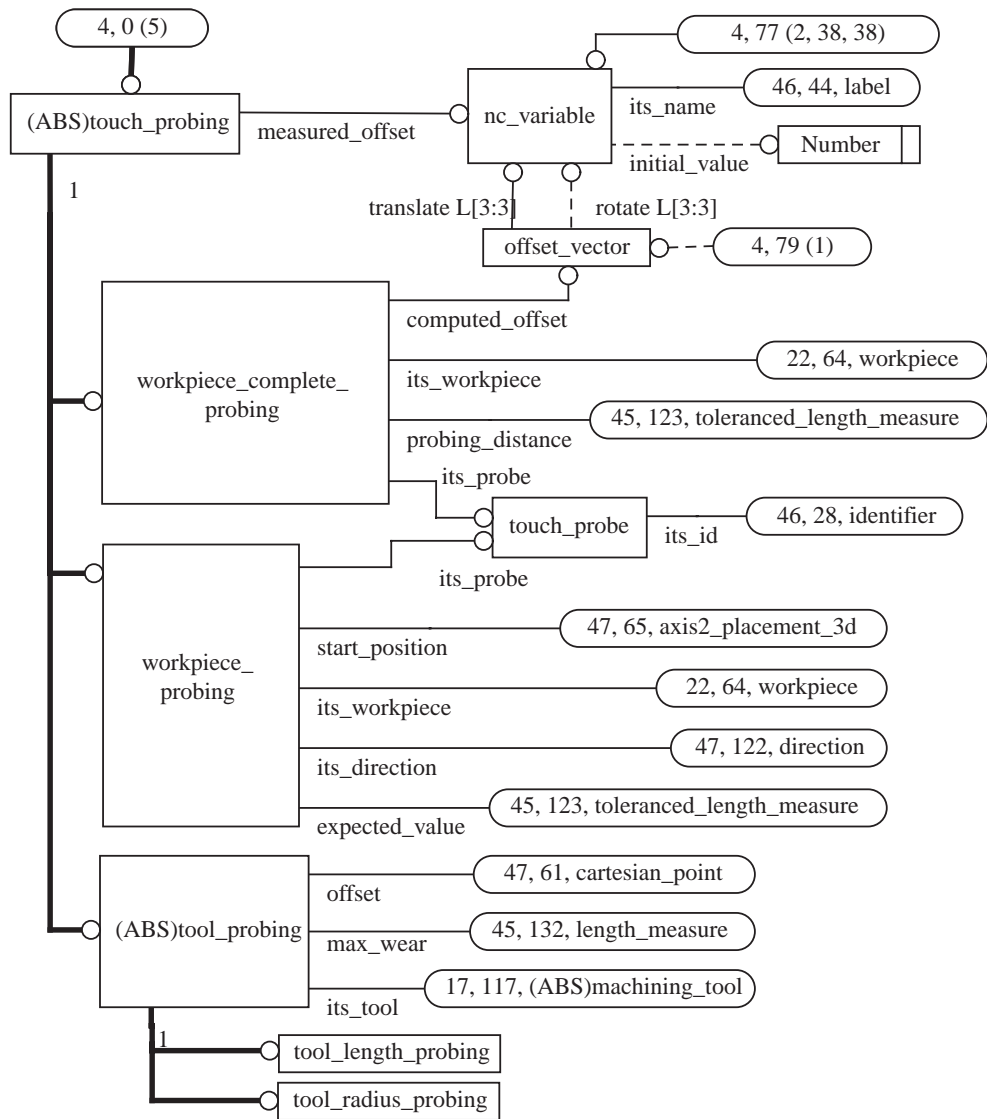


Figure G.2 — ARM diagram (2 of 48)

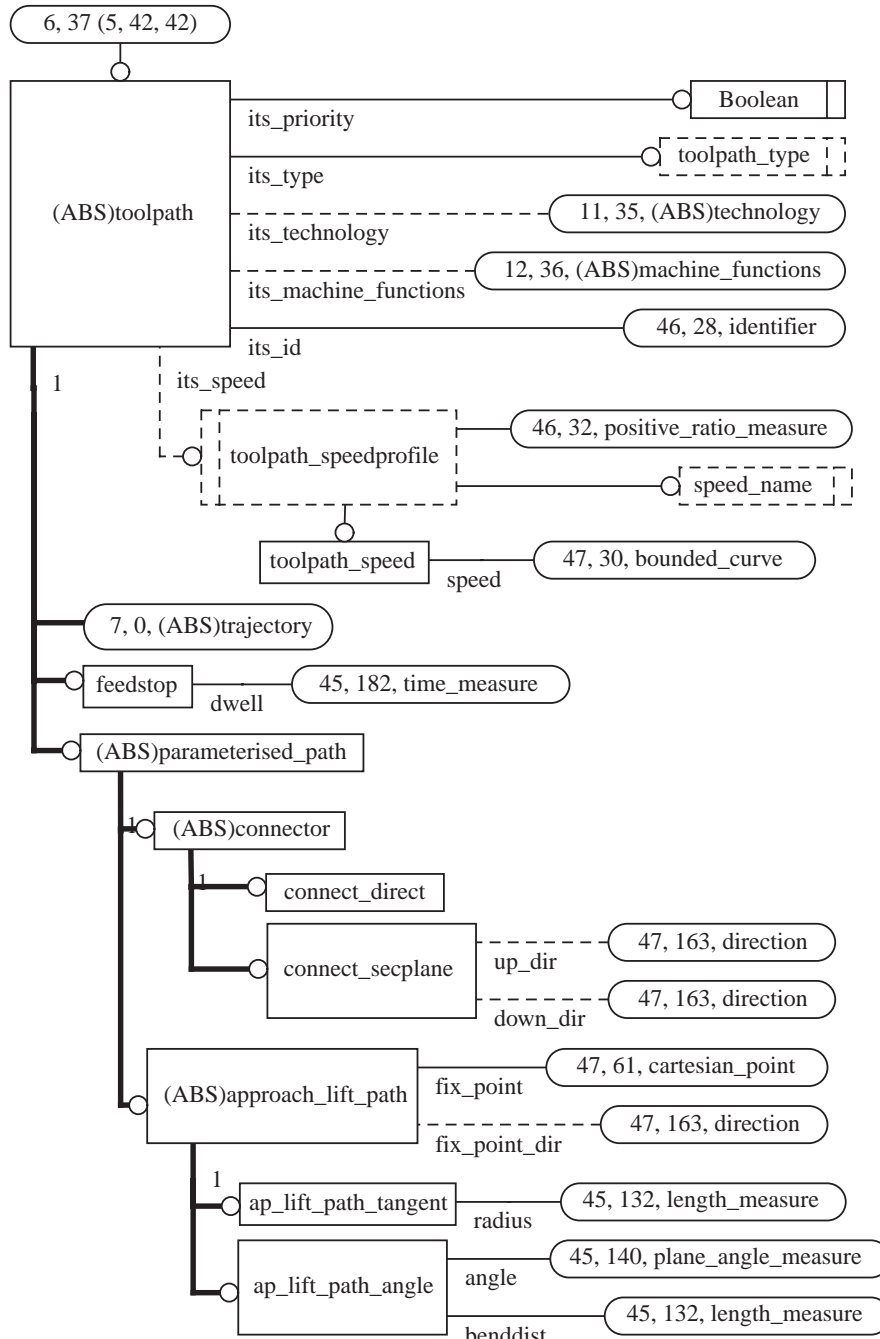


**Figure G.3 — ARM diagram (3 of 48)**



**Figure G.4 — ARM diagram (4 of 48)**





**Figure G.6 — ARM diagram (6 of 48)**

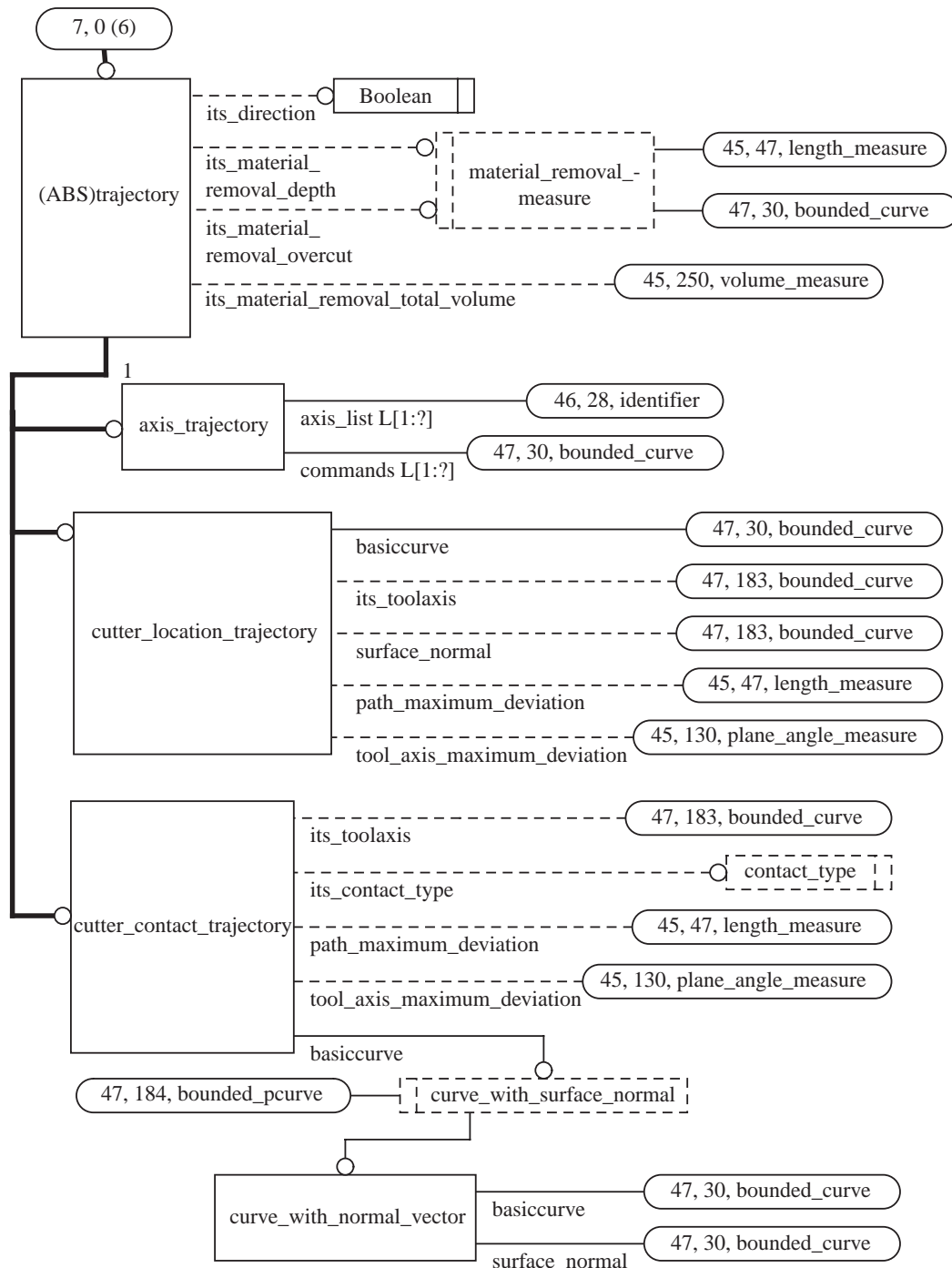


Figure G.7 — ARM diagram (7 of 48)

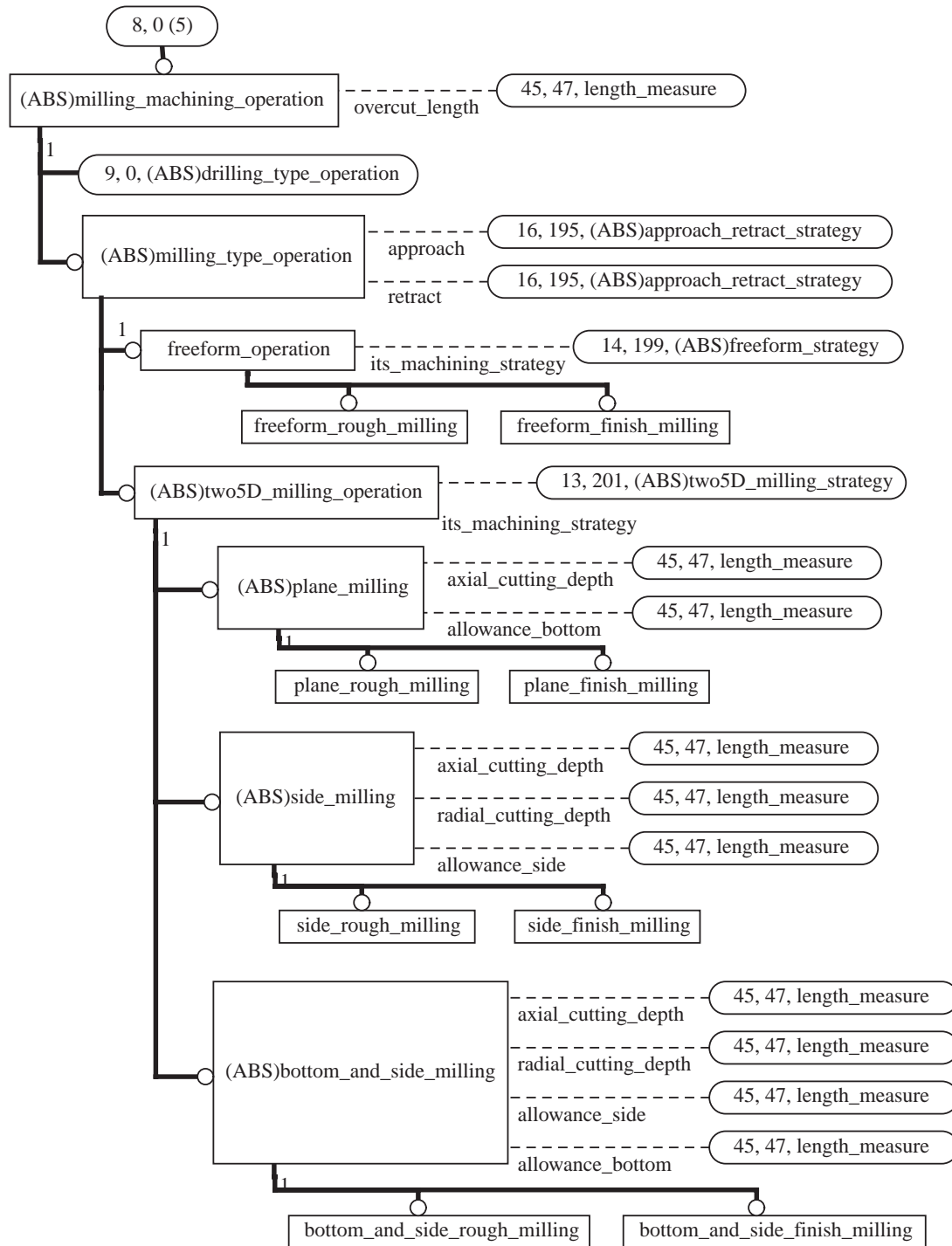
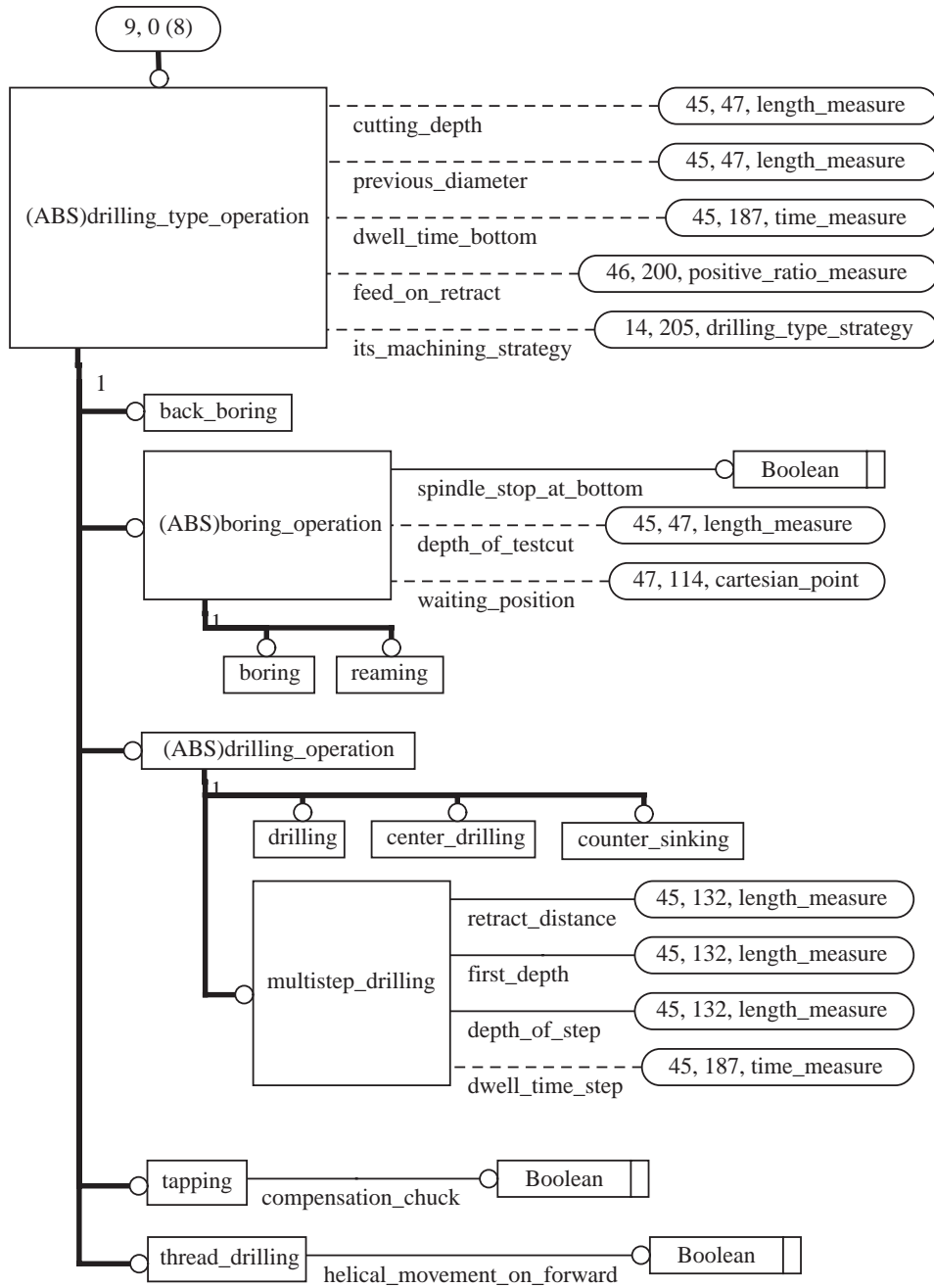


Figure G.8 — ARM diagram (8 of 48)





**Figure G.9 — ARM diagram (9 of 48)**

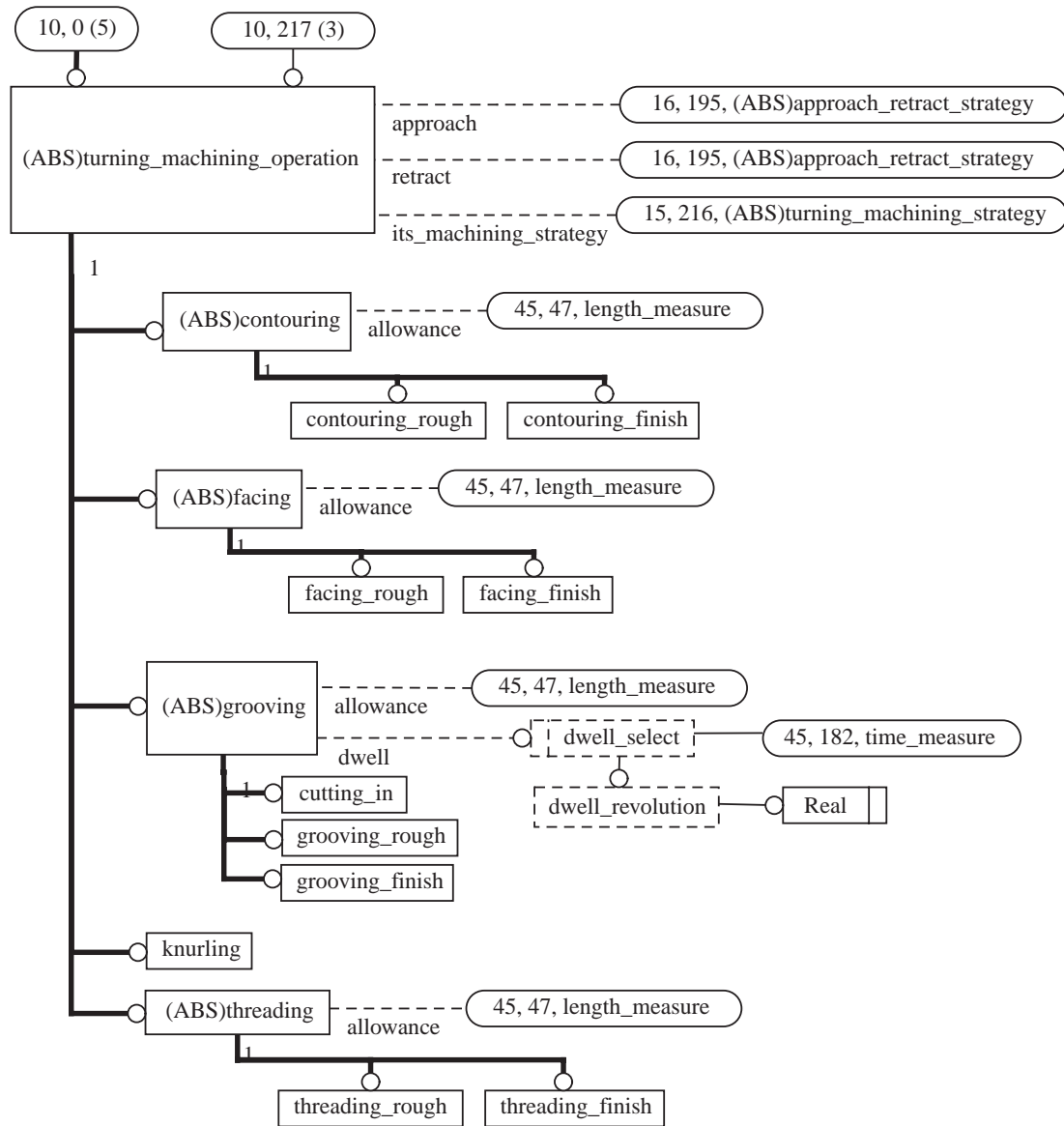
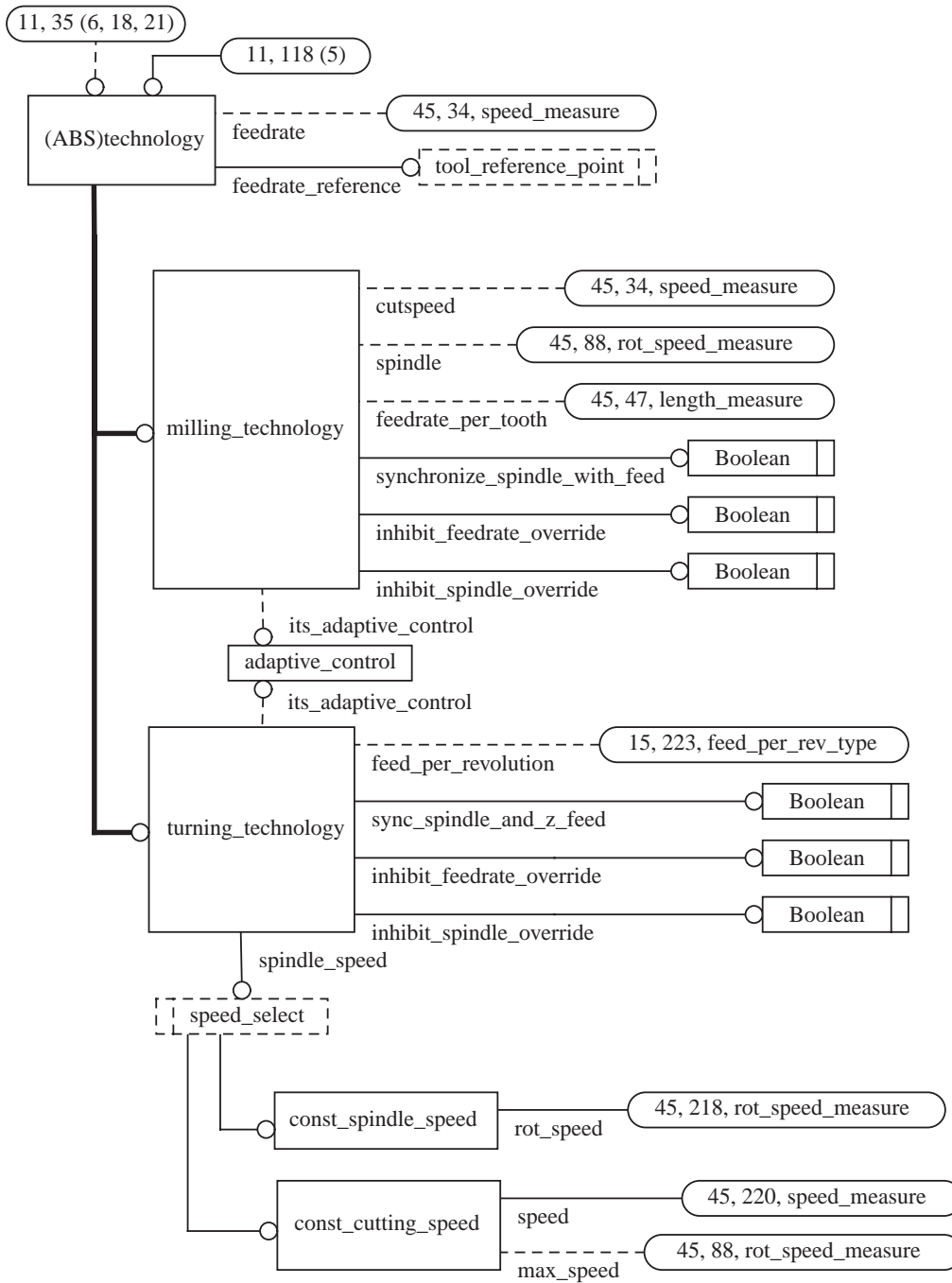
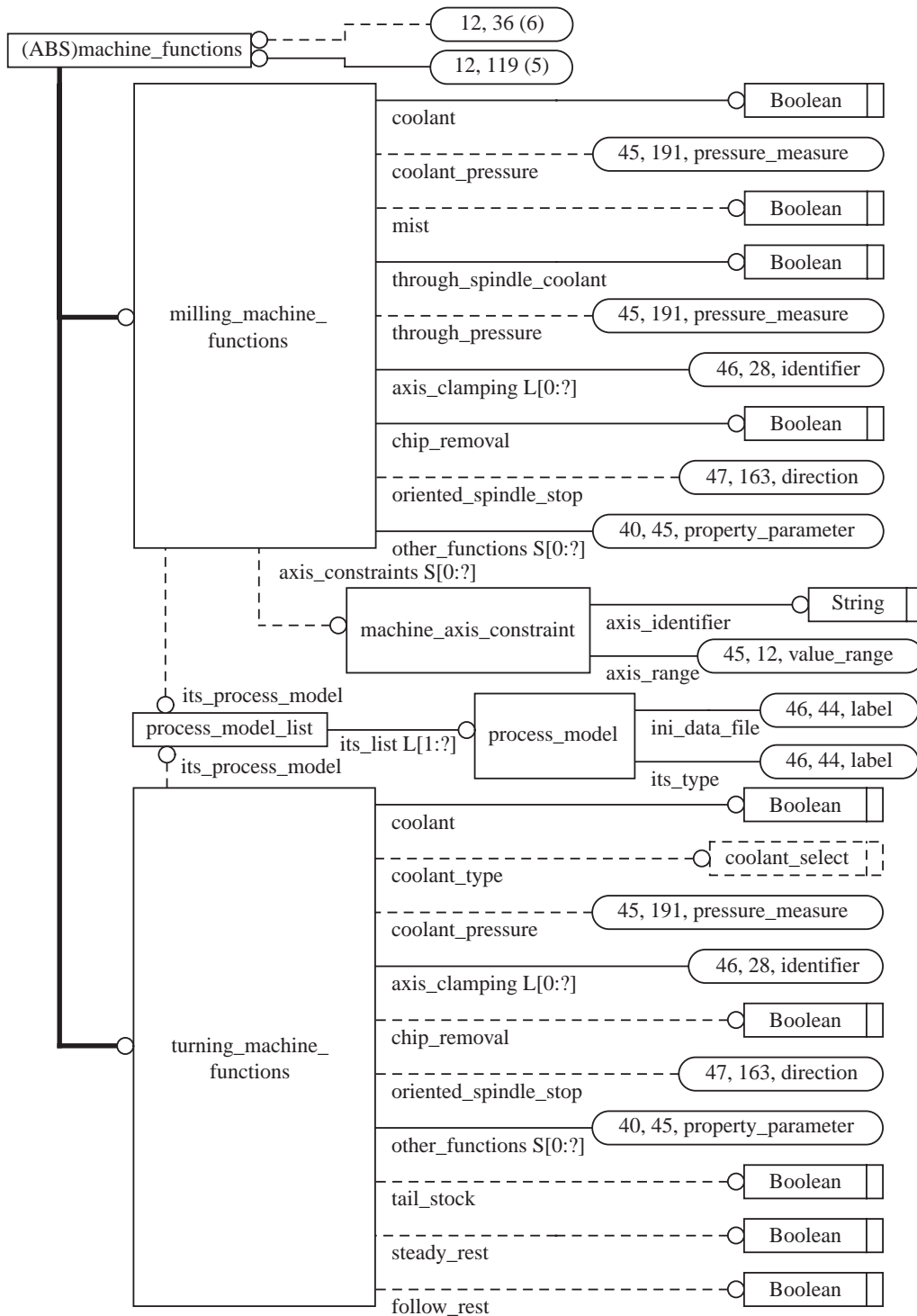


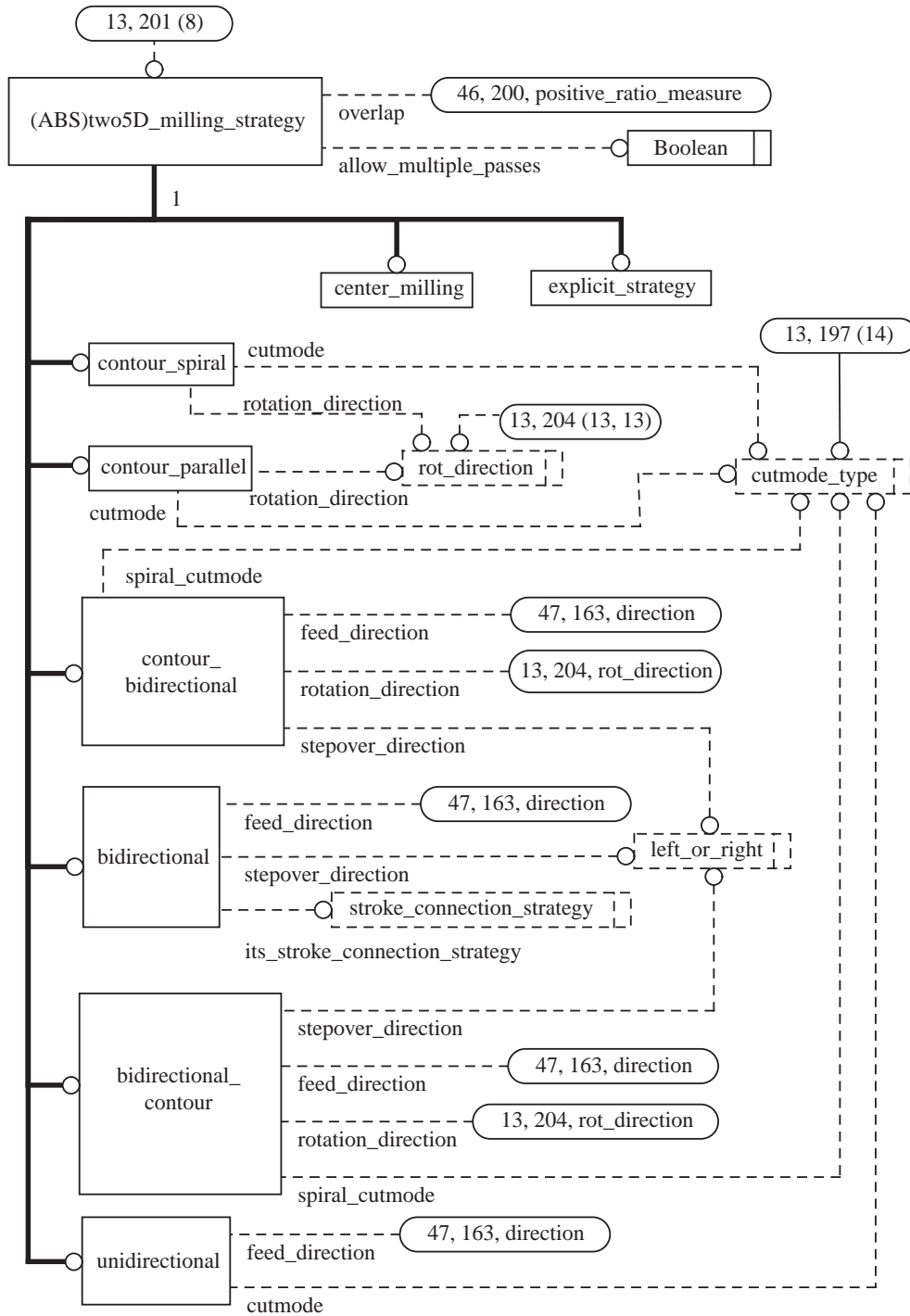
Figure G.10 — ARM diagram (10 of 48)



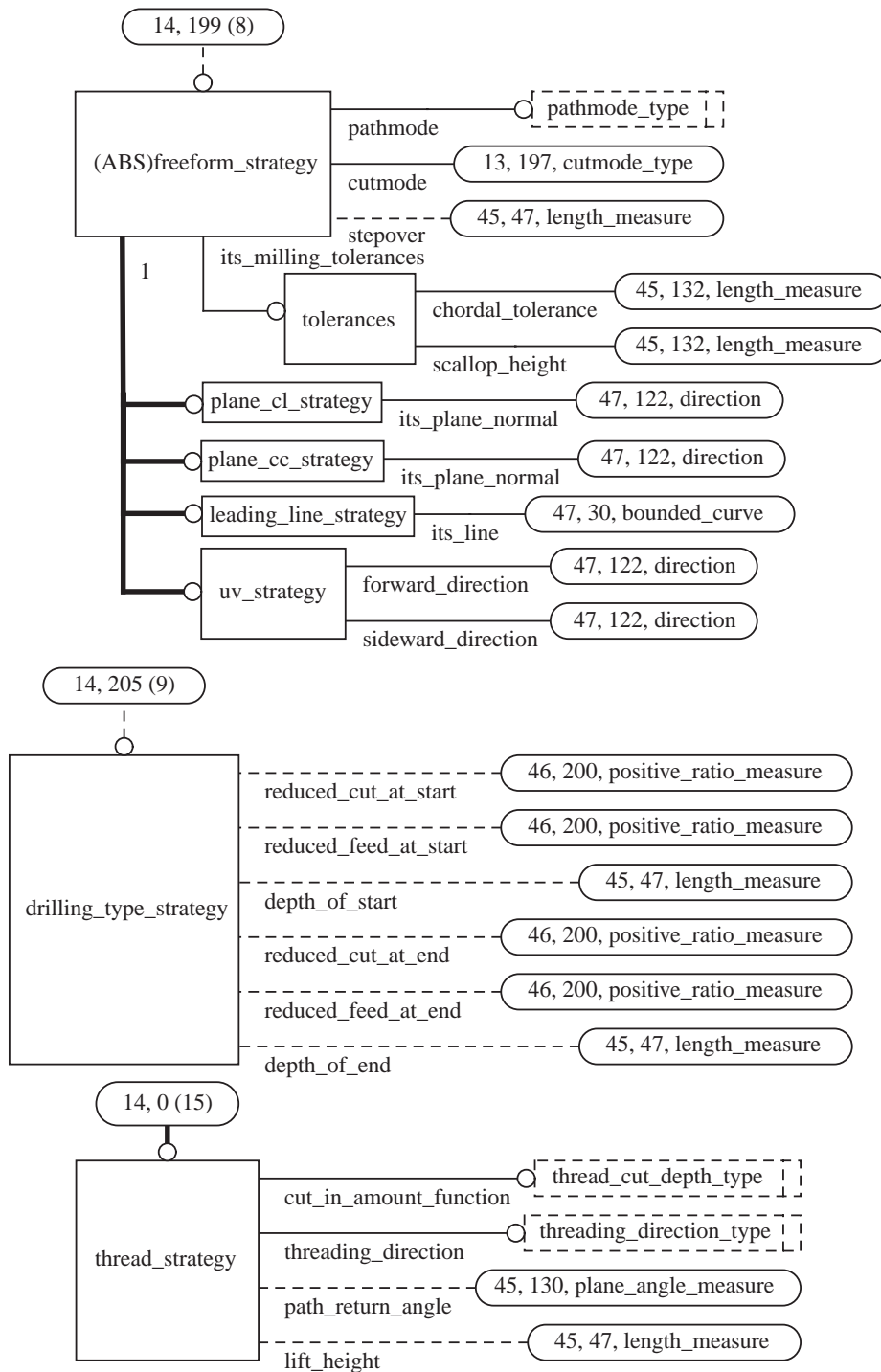
**Figure G.11 — ARM diagram (11 of 48)**



**Figure G.12 — ARM diagram (12 of 48)**



**Figure G.13 — ARM diagram (13 of 48)**



**Figure G.14 — ARM diagram (14 of 48)**

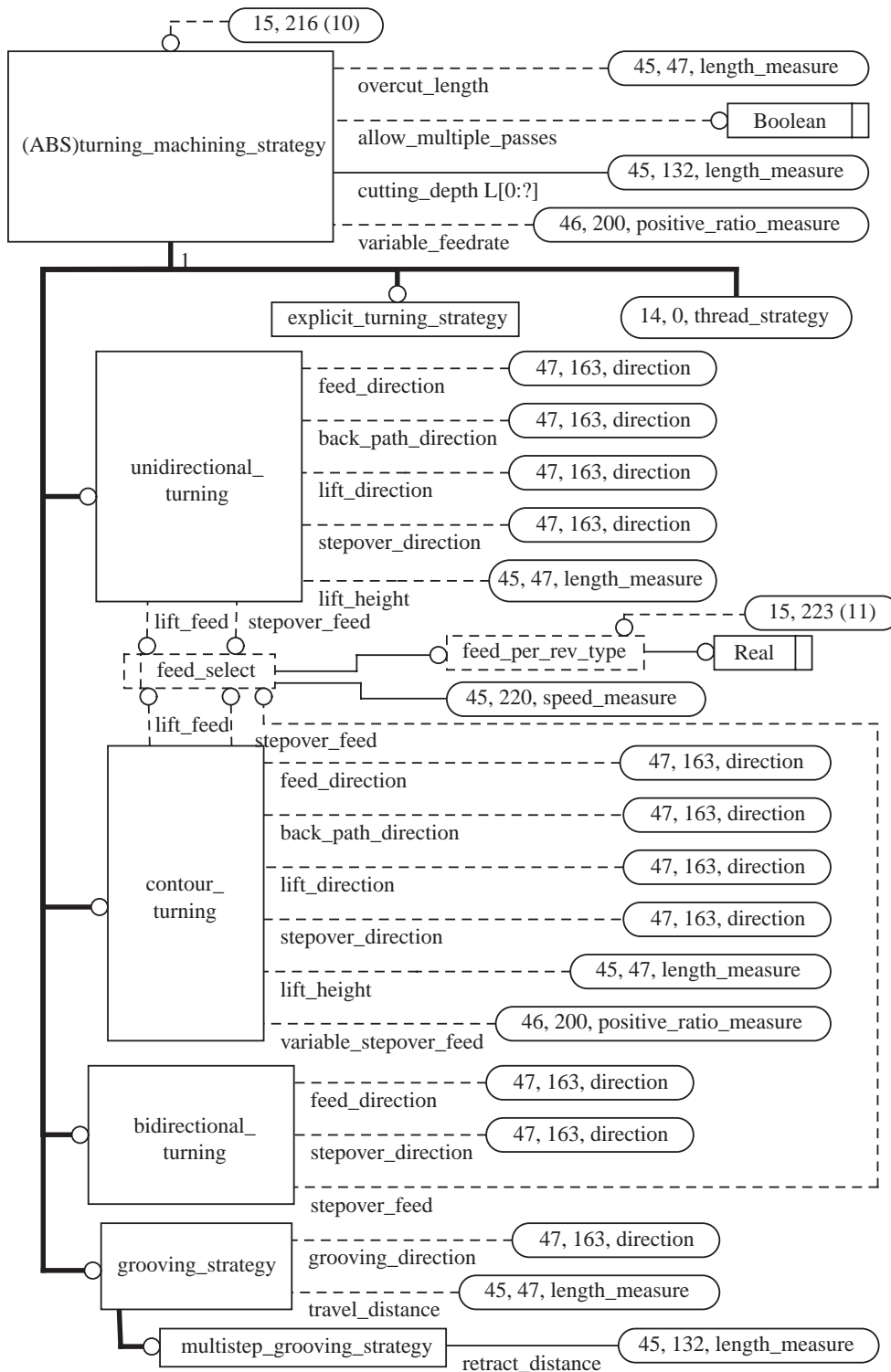


Figure G.15 — ARM diagram (15 of 48)

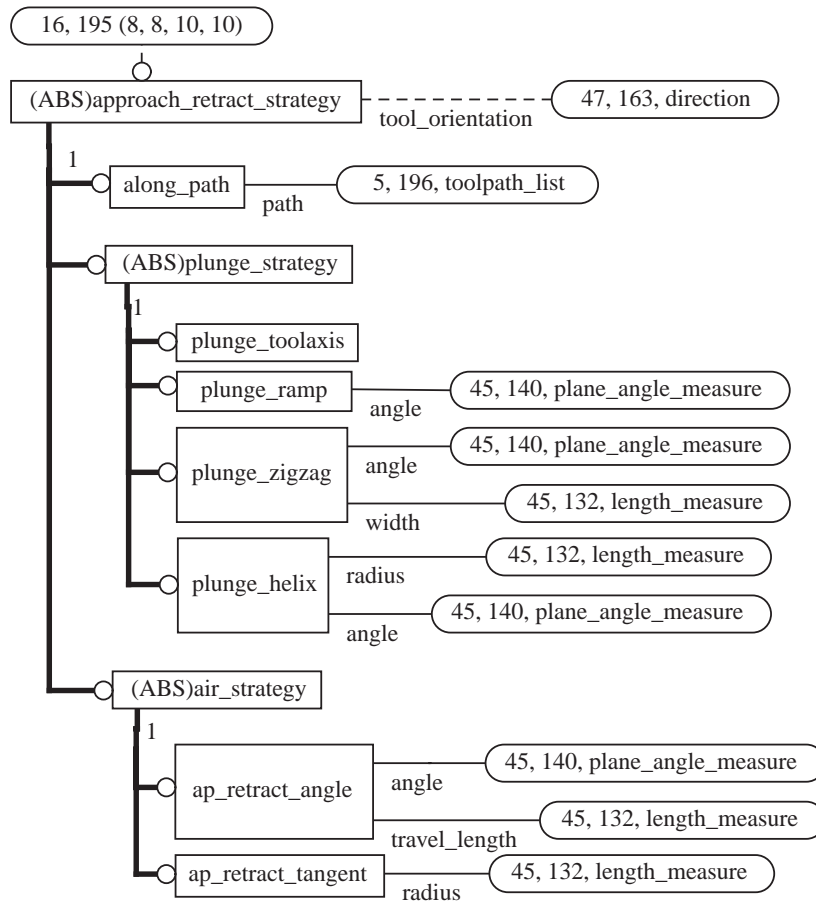
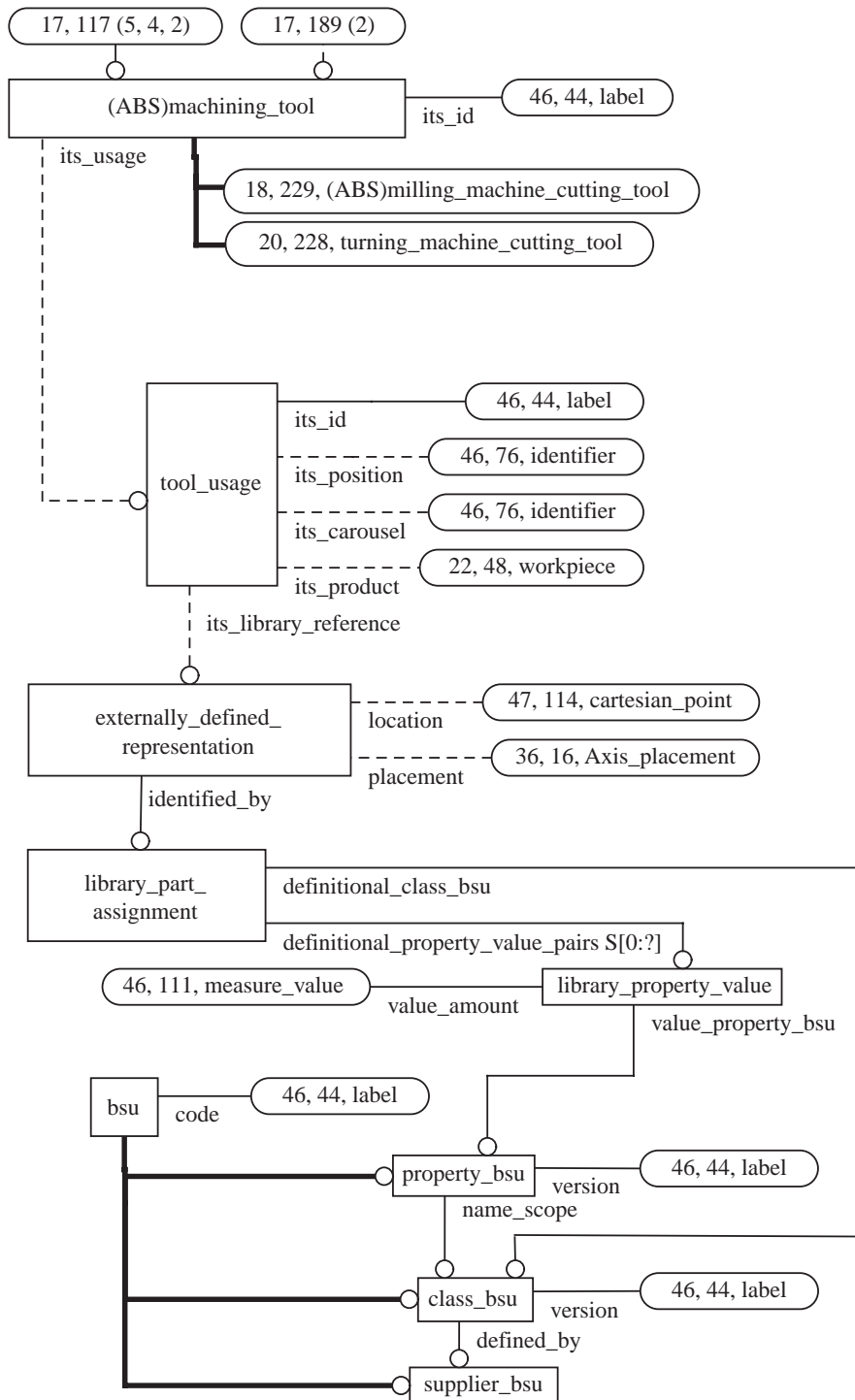


Figure G.16 — ARM diagram (16 of 48)





**Figure G.17 — ARM diagram (17 of 48)**

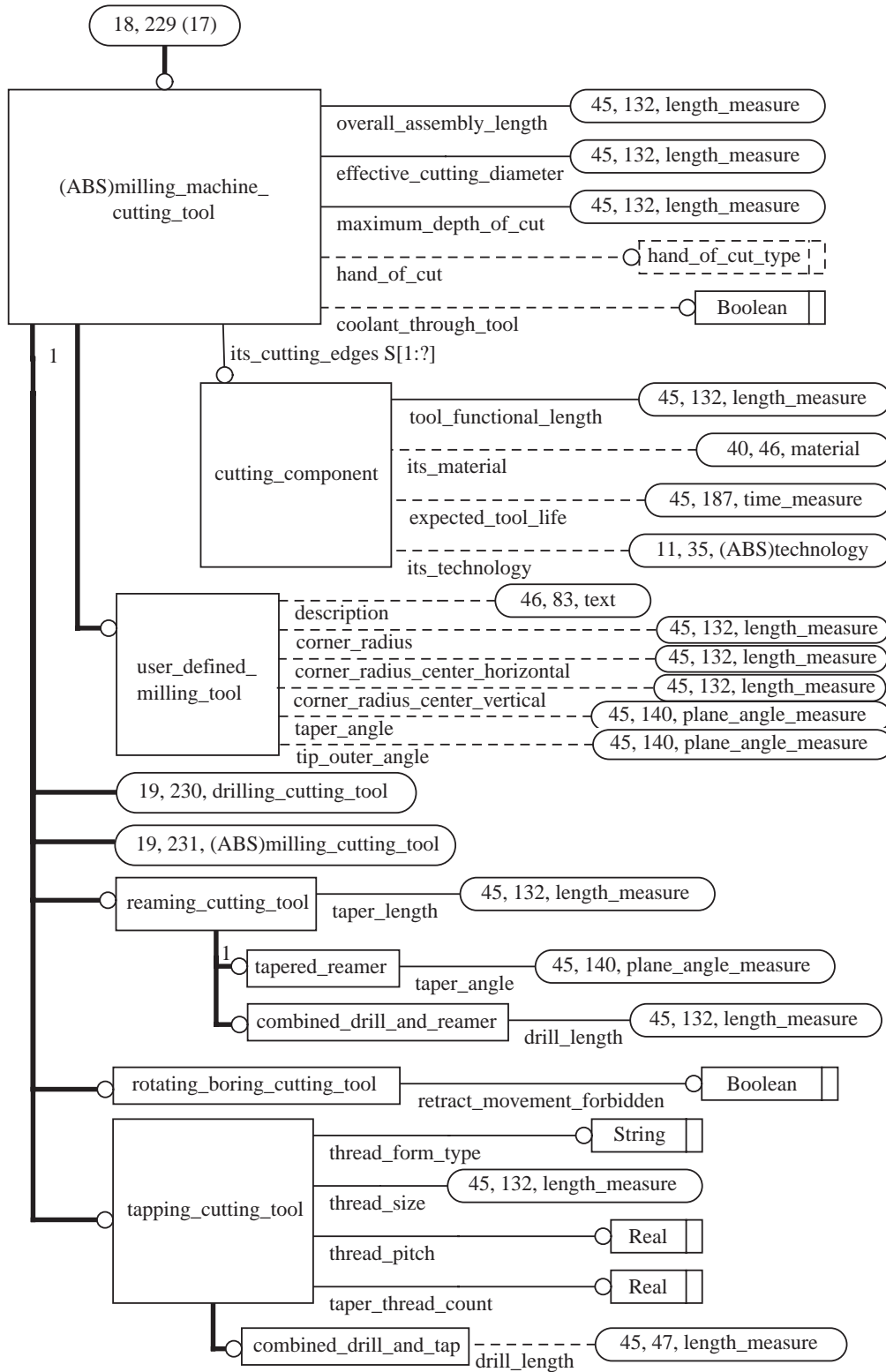
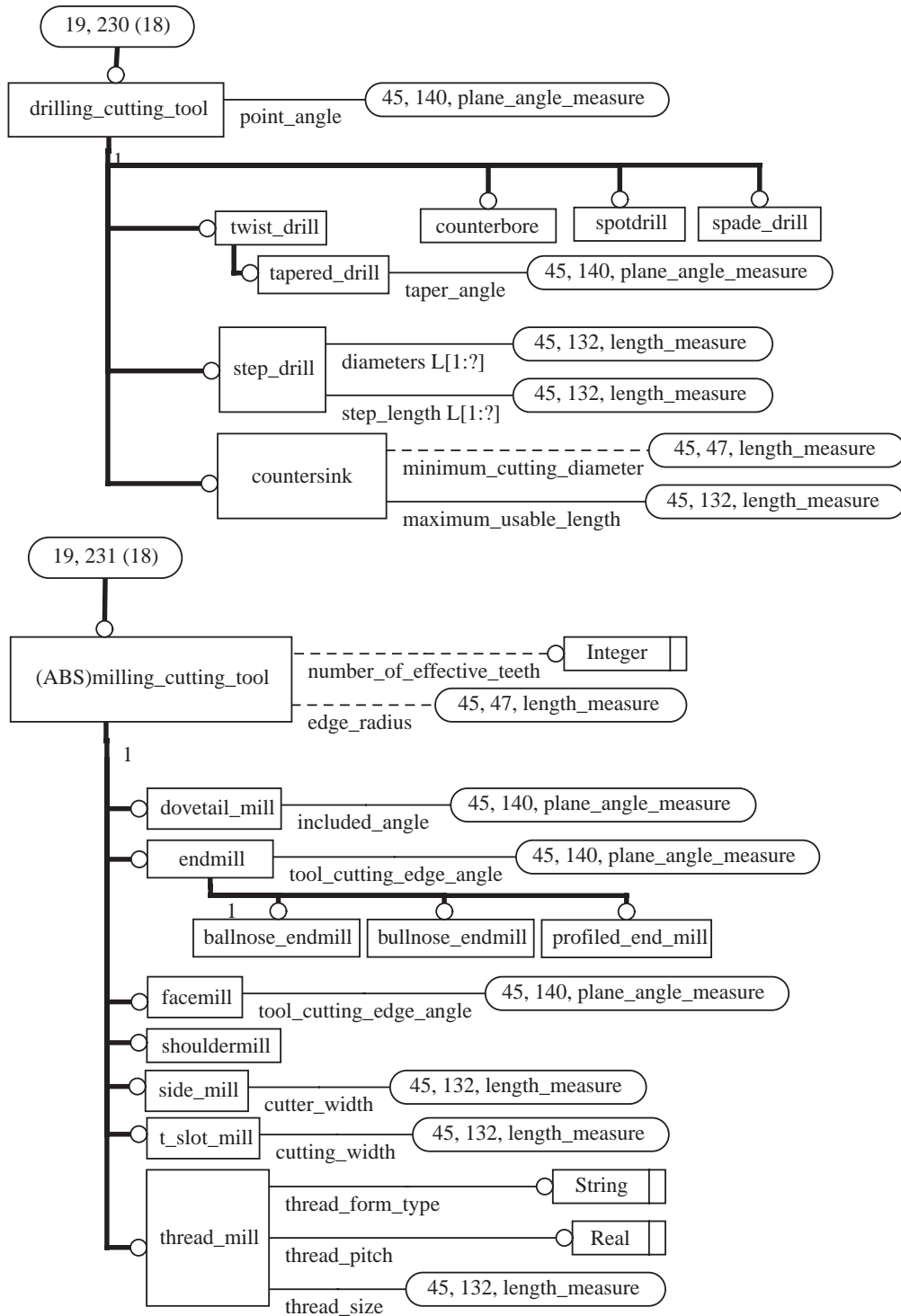
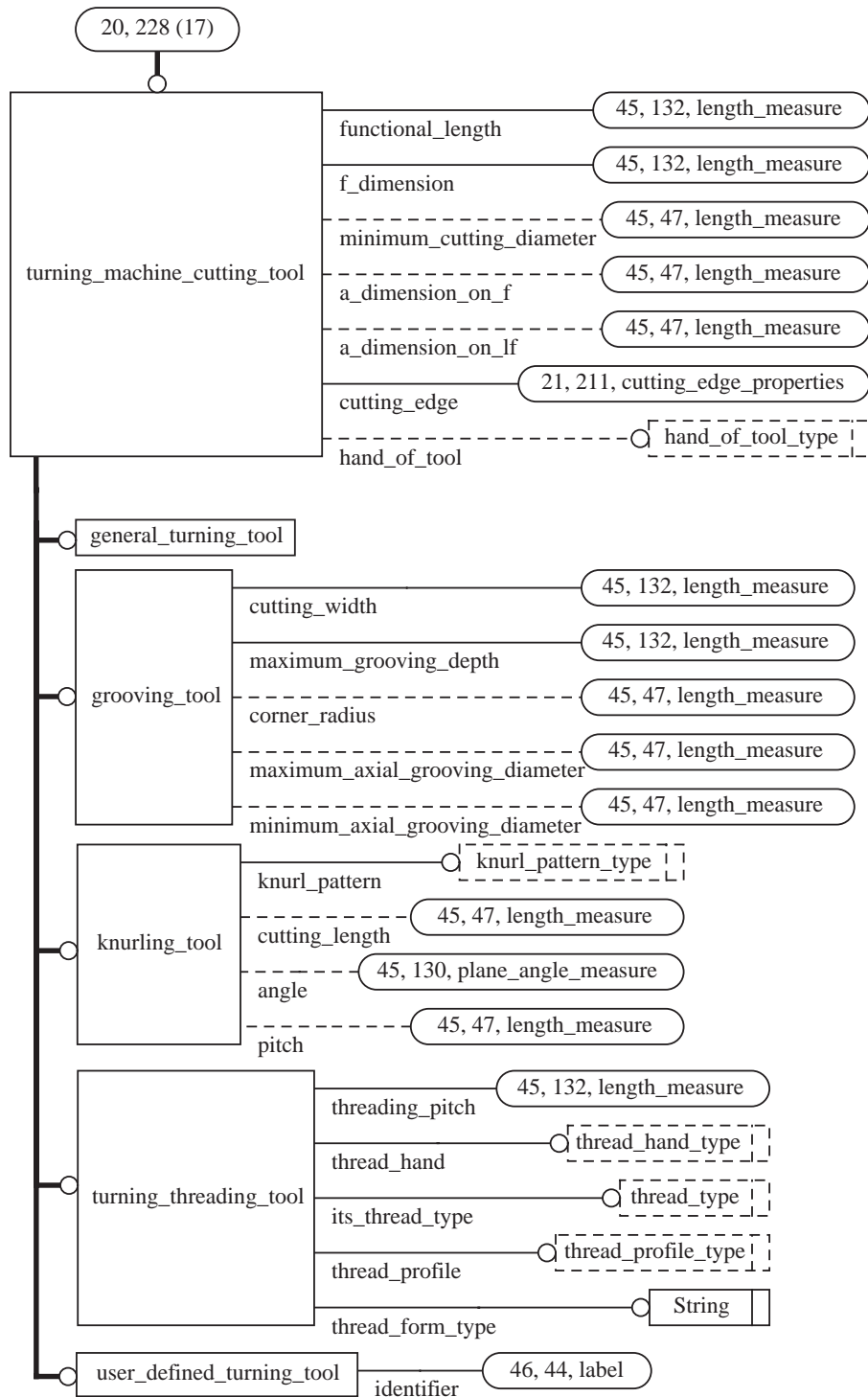


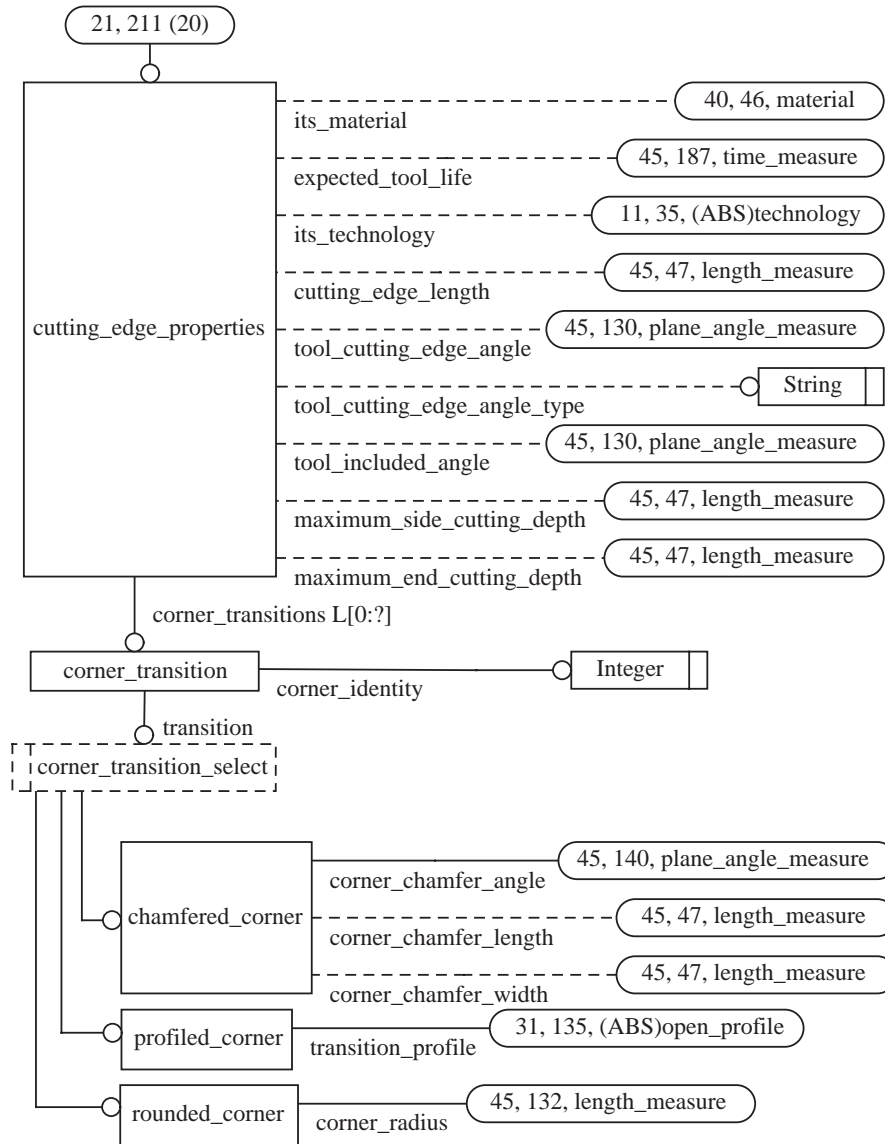
Figure G.18 — ARM diagram (18 of 48)



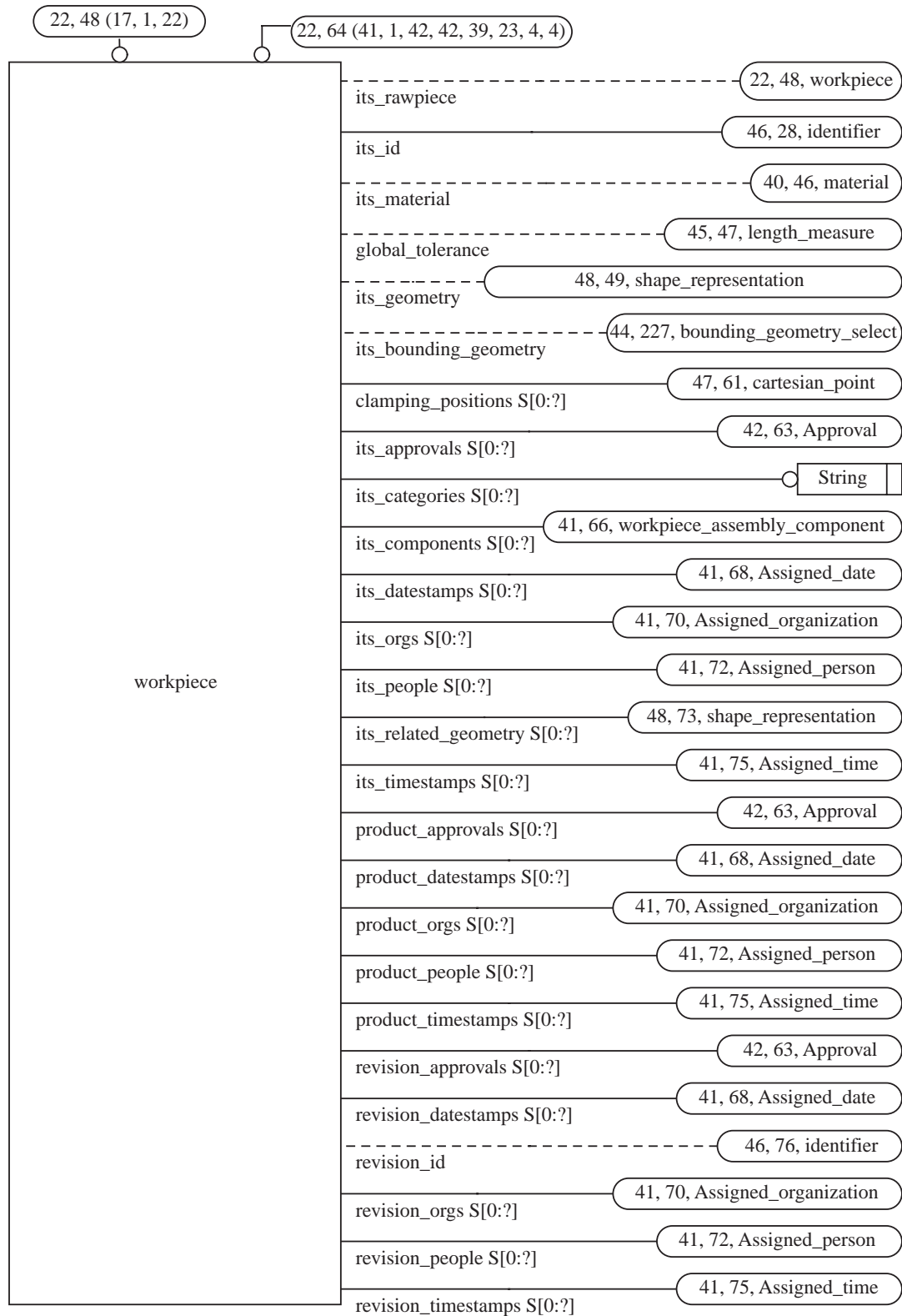
**Figure G.19 — ARM diagram (19 of 48)**



**Figure G.20 — ARM diagram (20 of 48)**



**Figure G.21 — ARM diagram (21 of 48)**



**Figure G.22 — ARM diagram (22 of 48)**

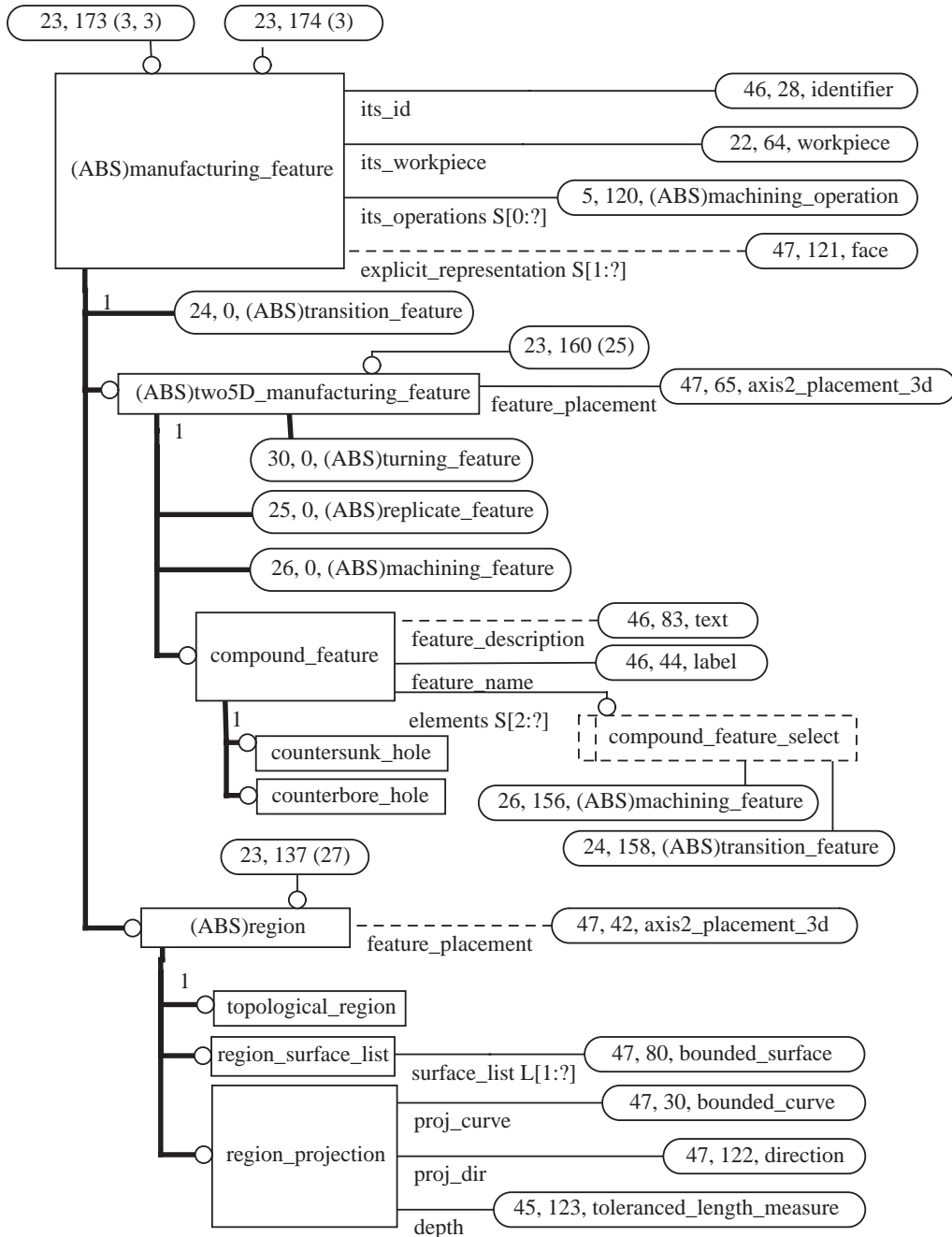
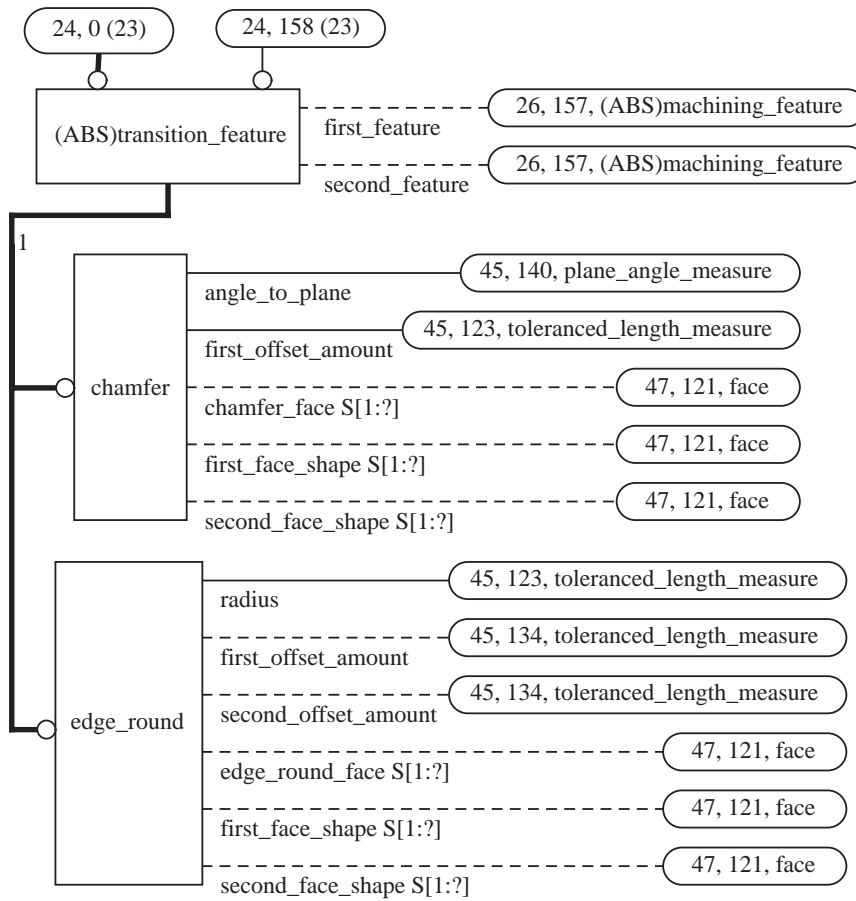


Figure G.23 — ARM diagram (23 of 48)



**Figure G.24 — ARM diagram (24 of 48)**



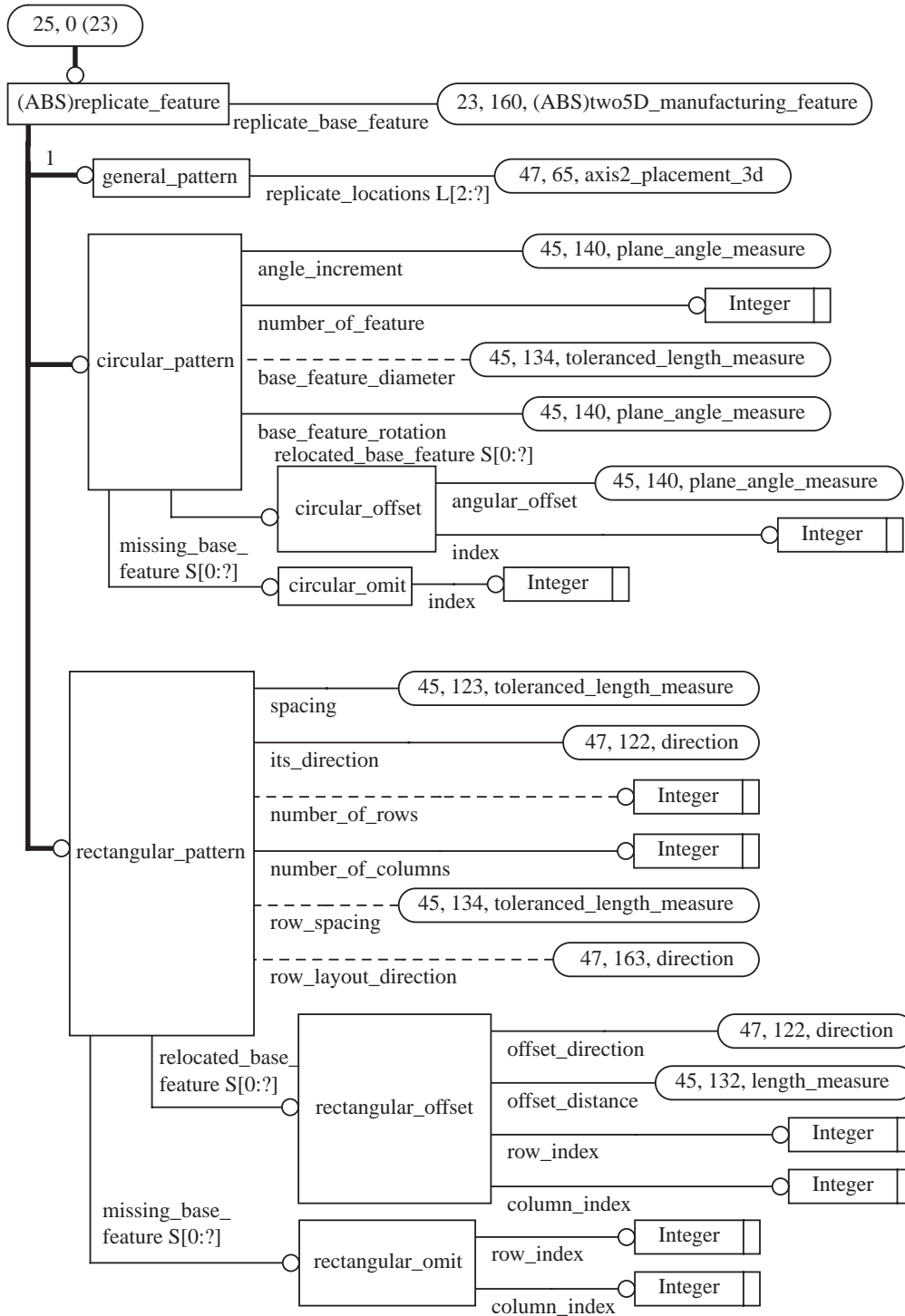
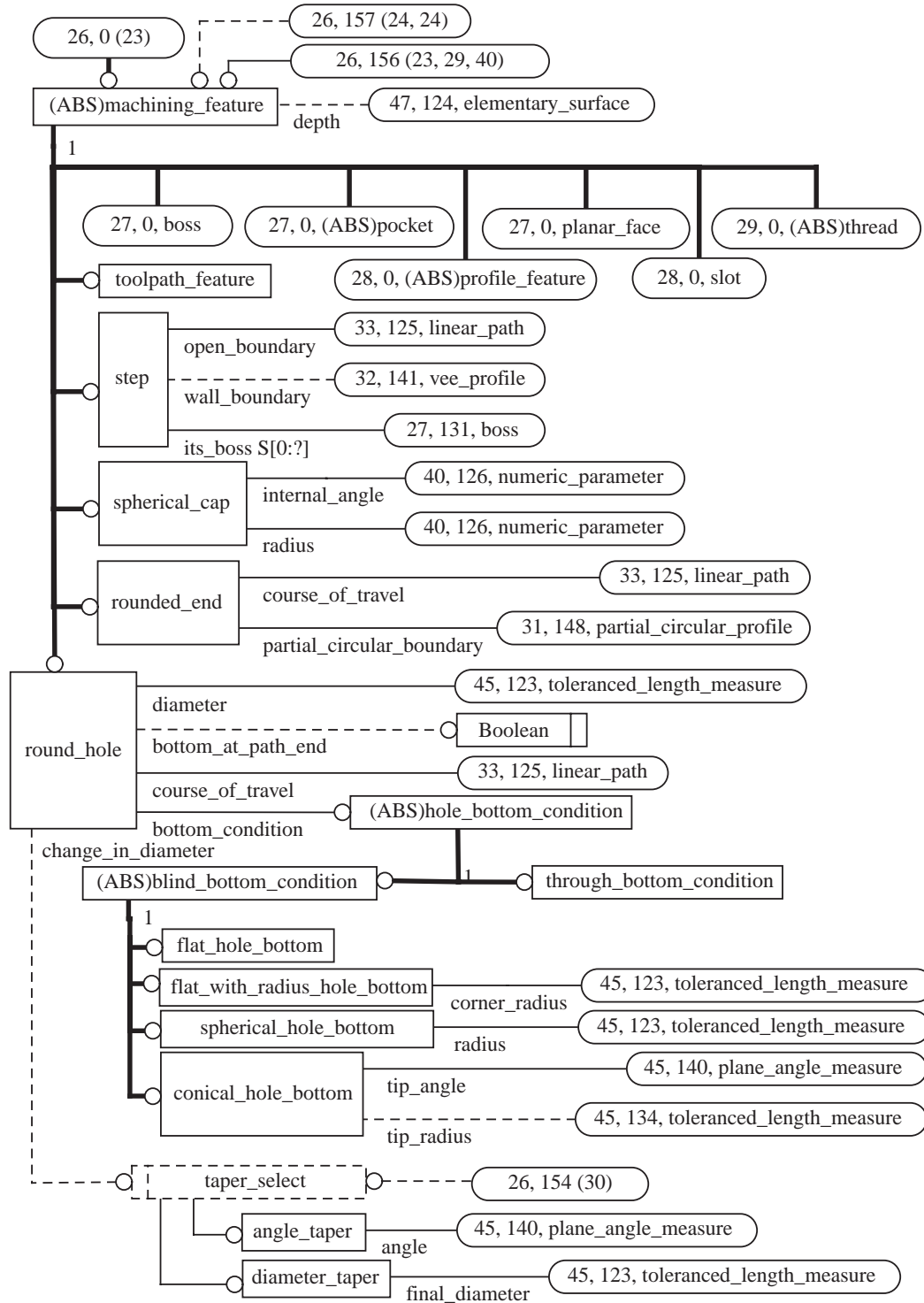
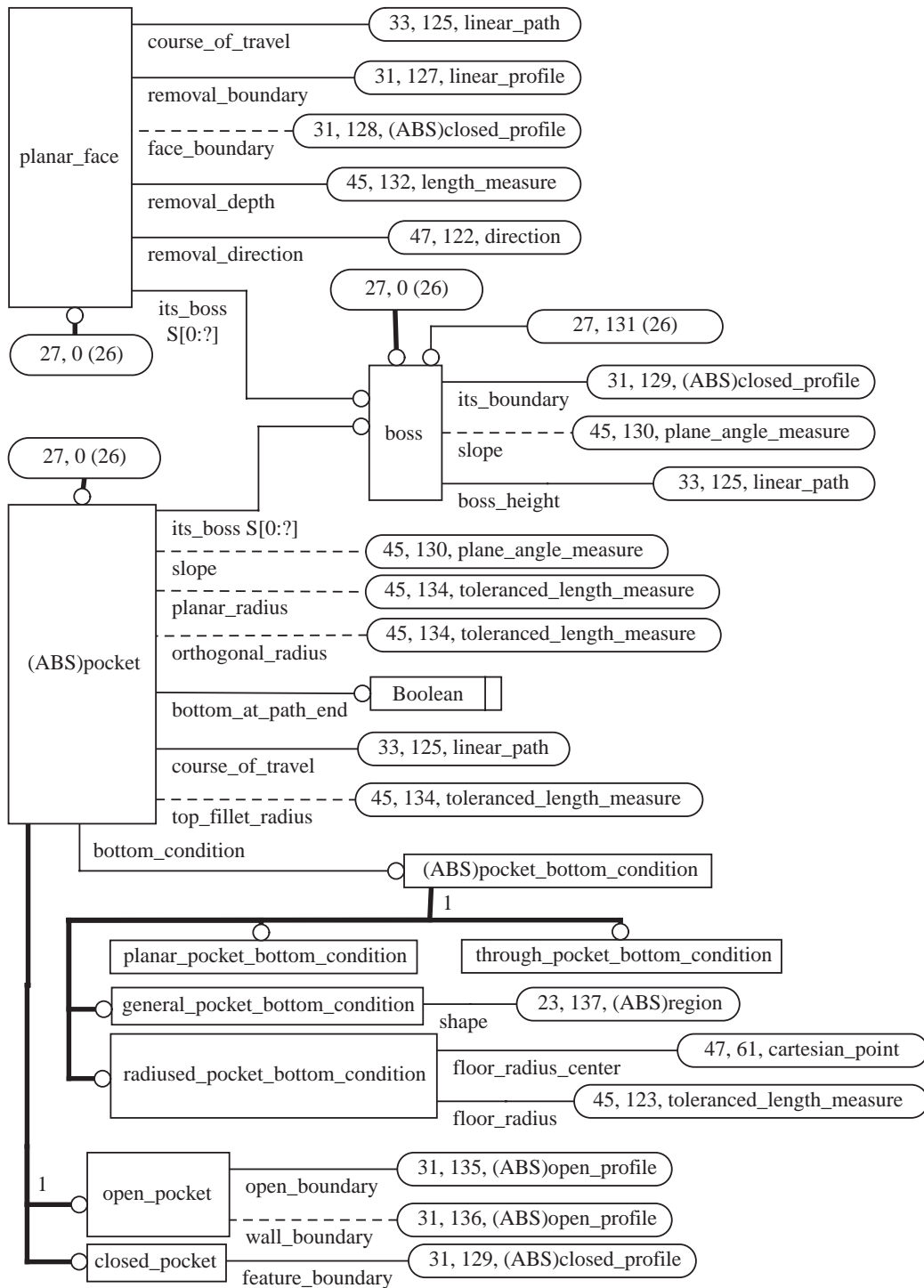


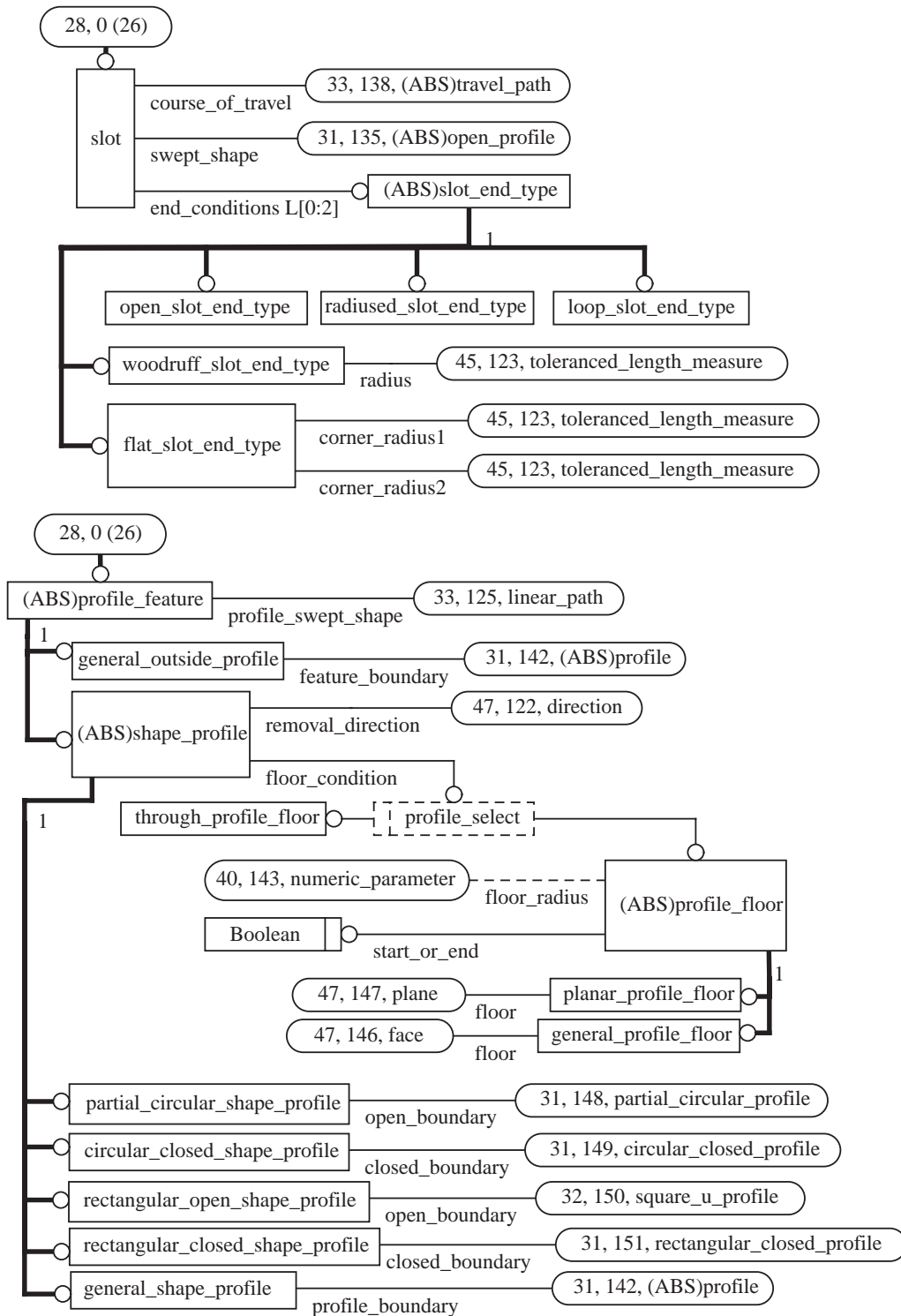
Figure G.25 — ARM diagram (25 of 48)



**Figure G.26 — ARM diagram (26 of 48)**



**Figure G.27 — ARM diagram (27 of 48)**



**Figure G.28 — ARM diagram (28 of 48)**

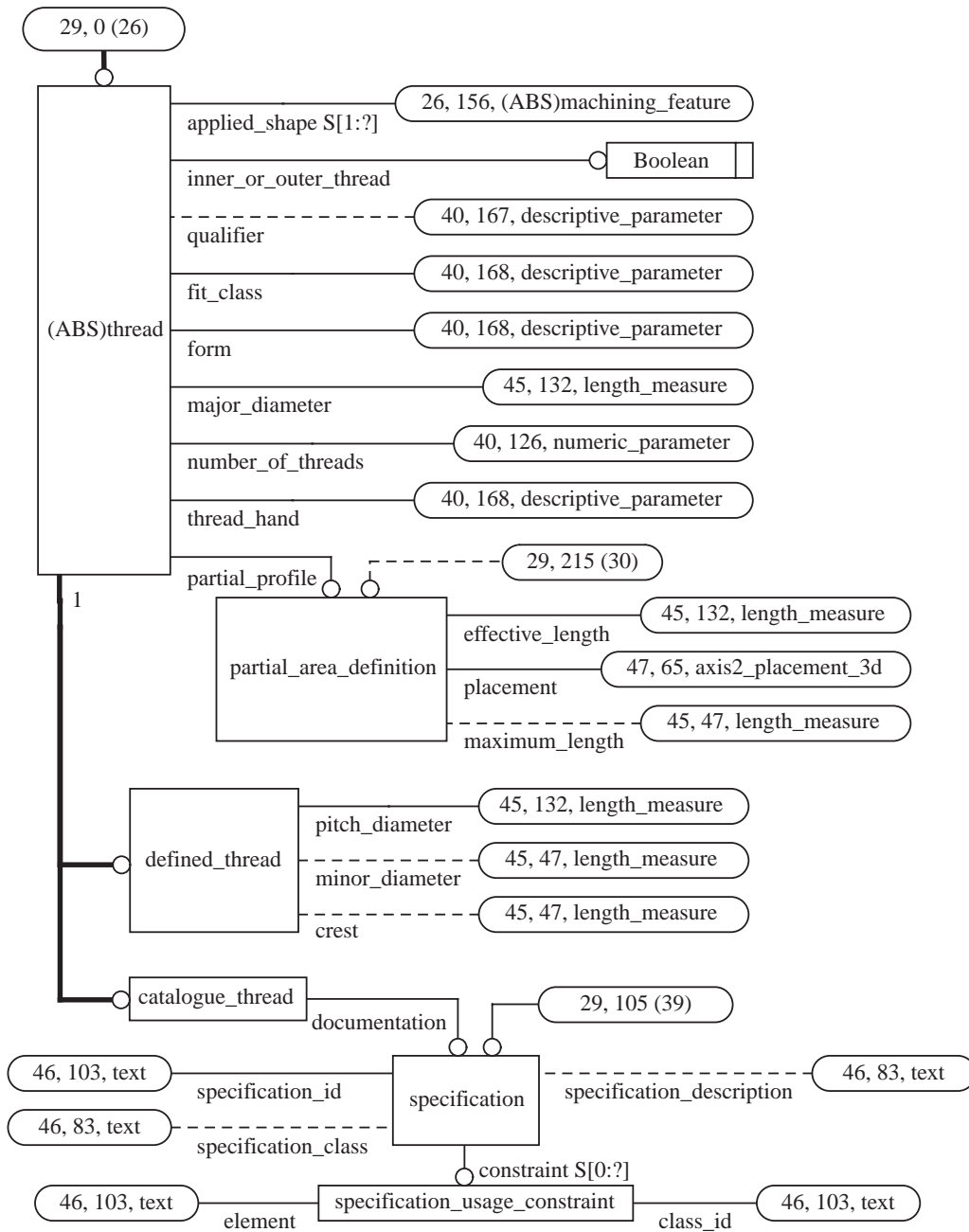
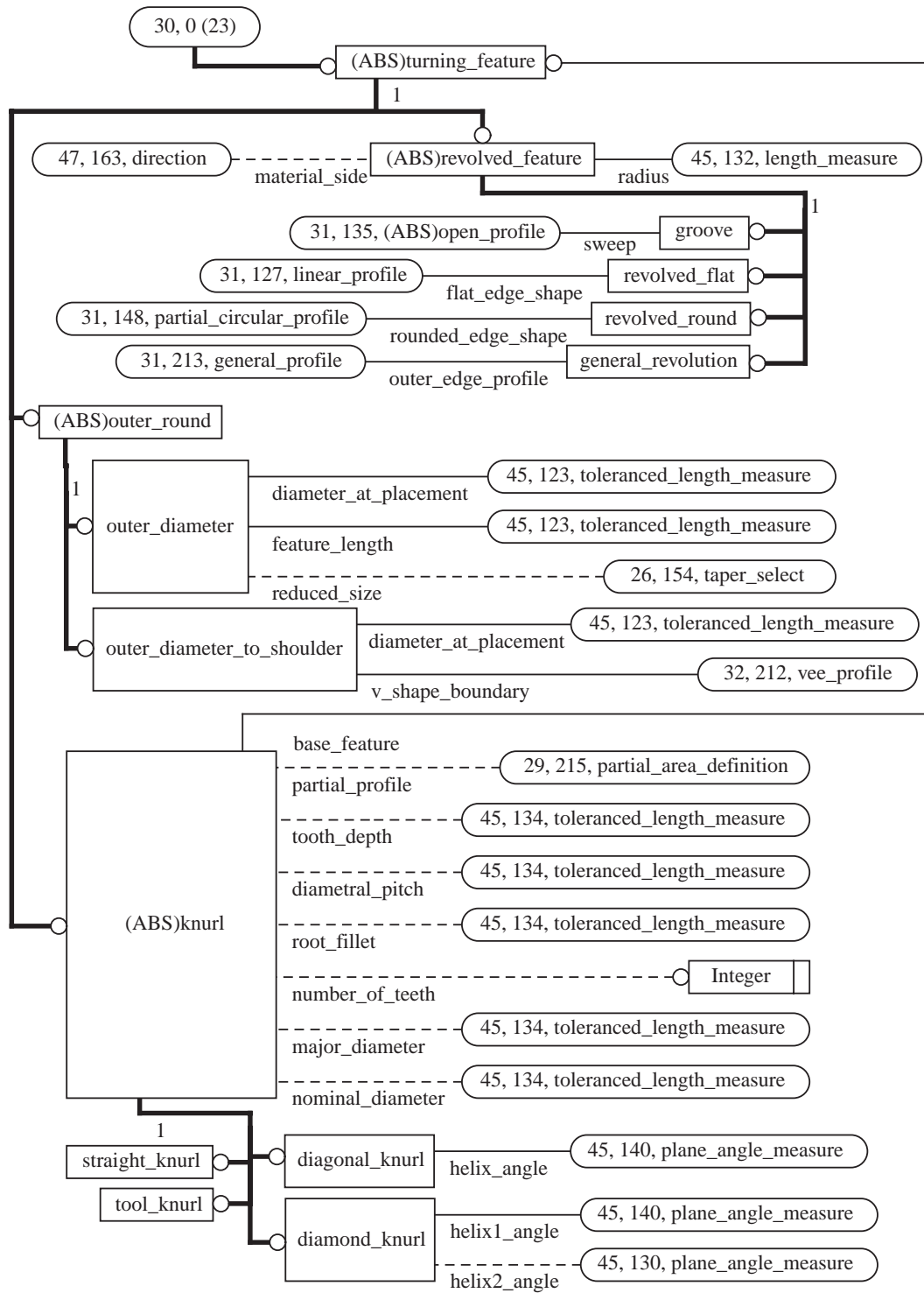
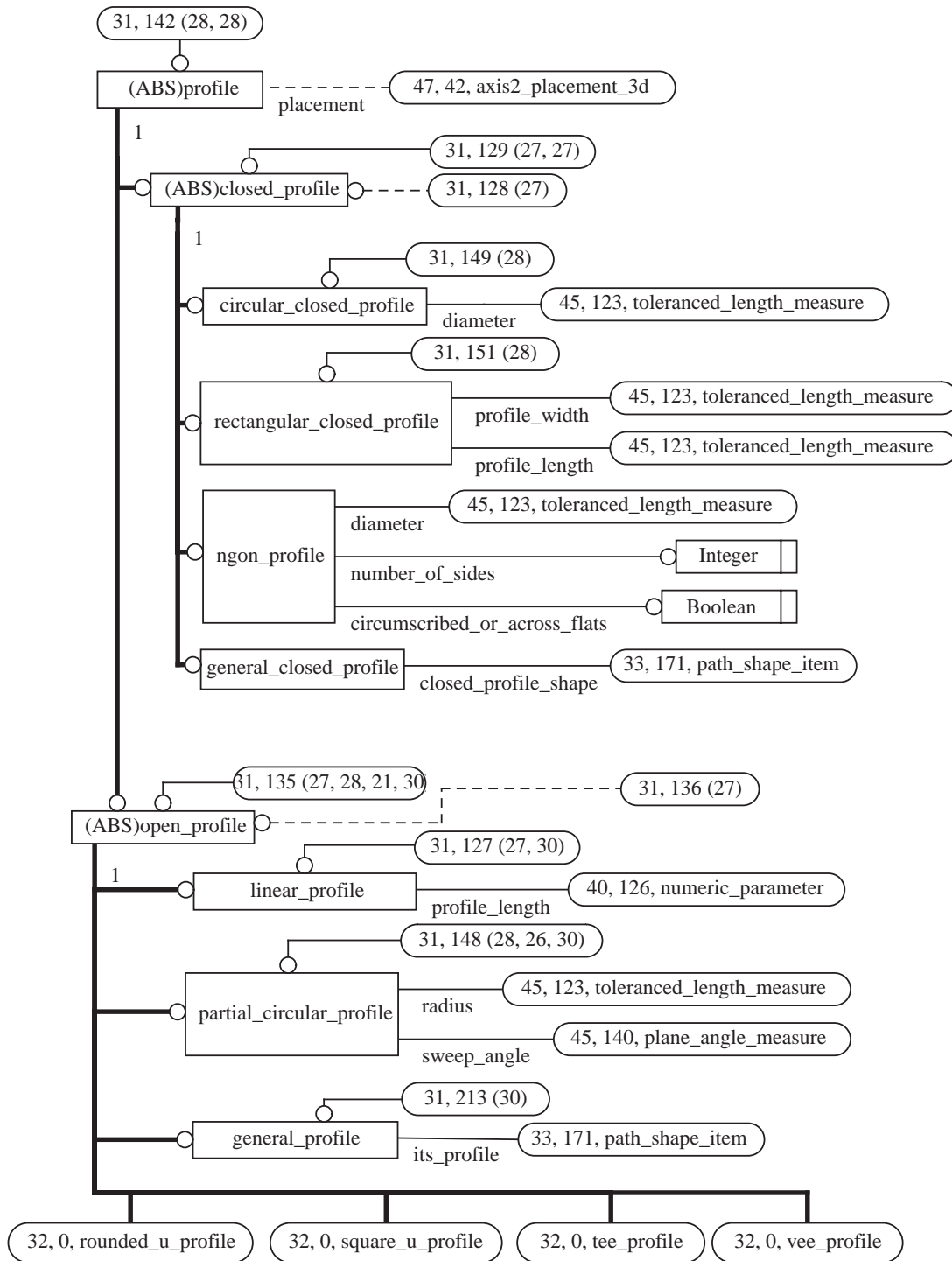


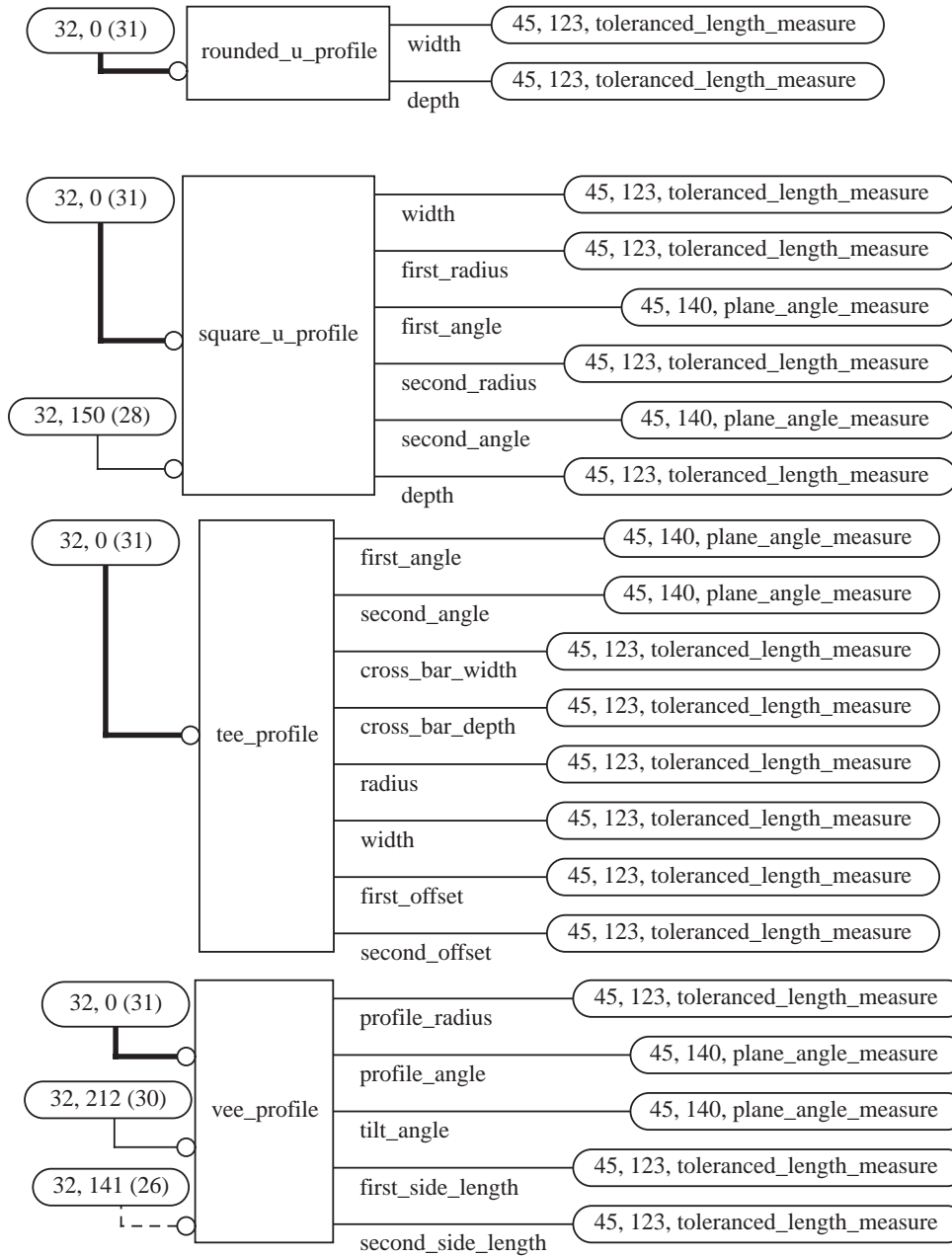
Figure G.29 — ARM diagram (29 of 48)



**Figure G.30 — ARM diagram (30 of 48)**

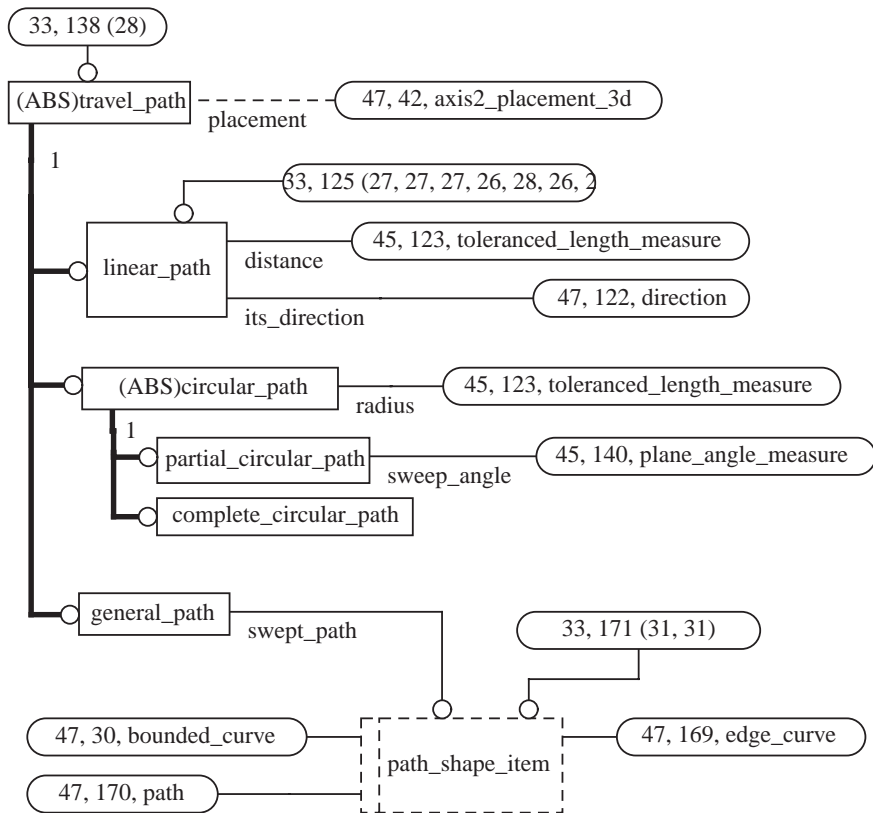


**Figure G.31 — ARM diagram (31 of 48)**



**Figure G.32 — ARM diagram (32 of 48)**





**Figure G.33 — ARM diagram (33 of 48)**

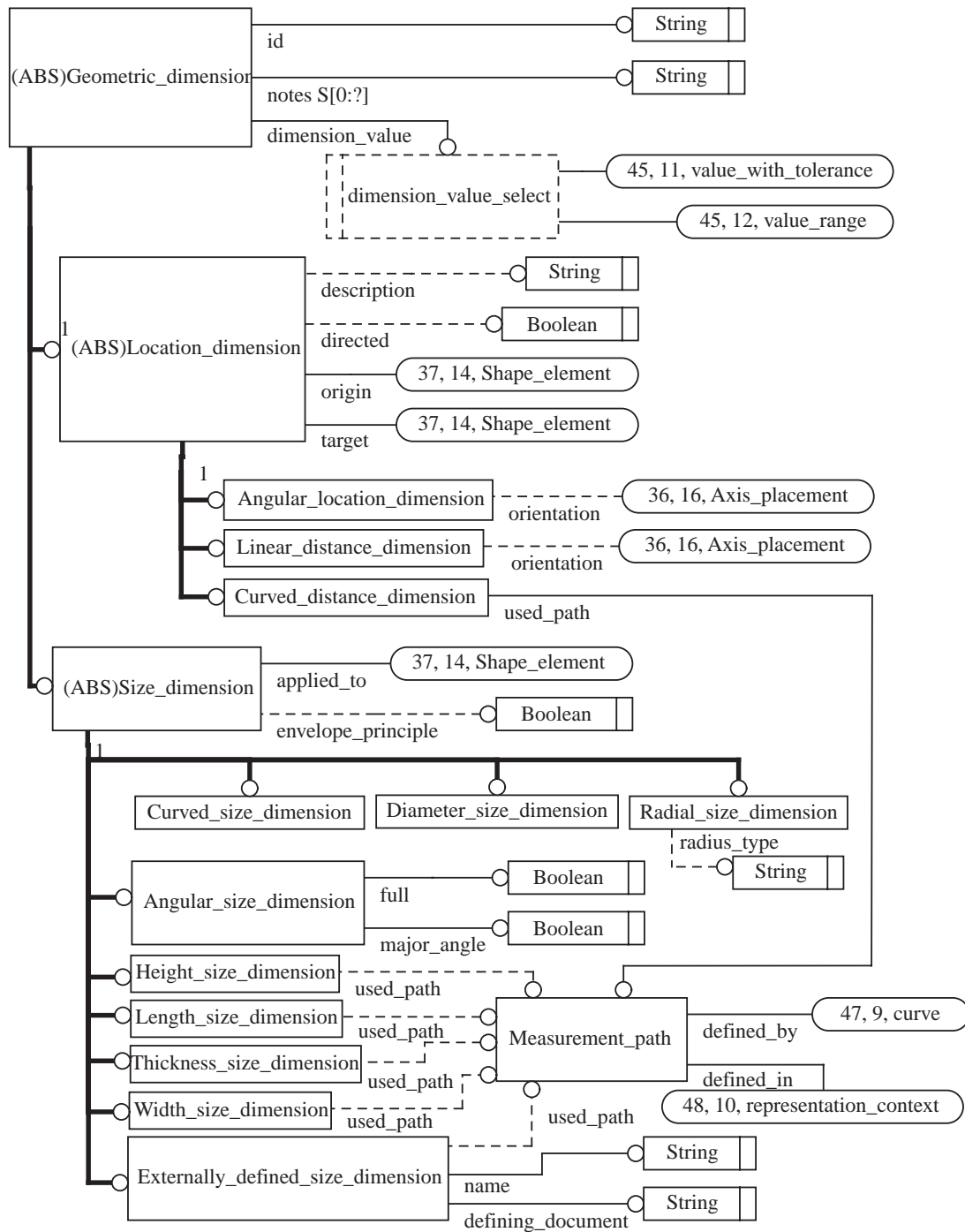
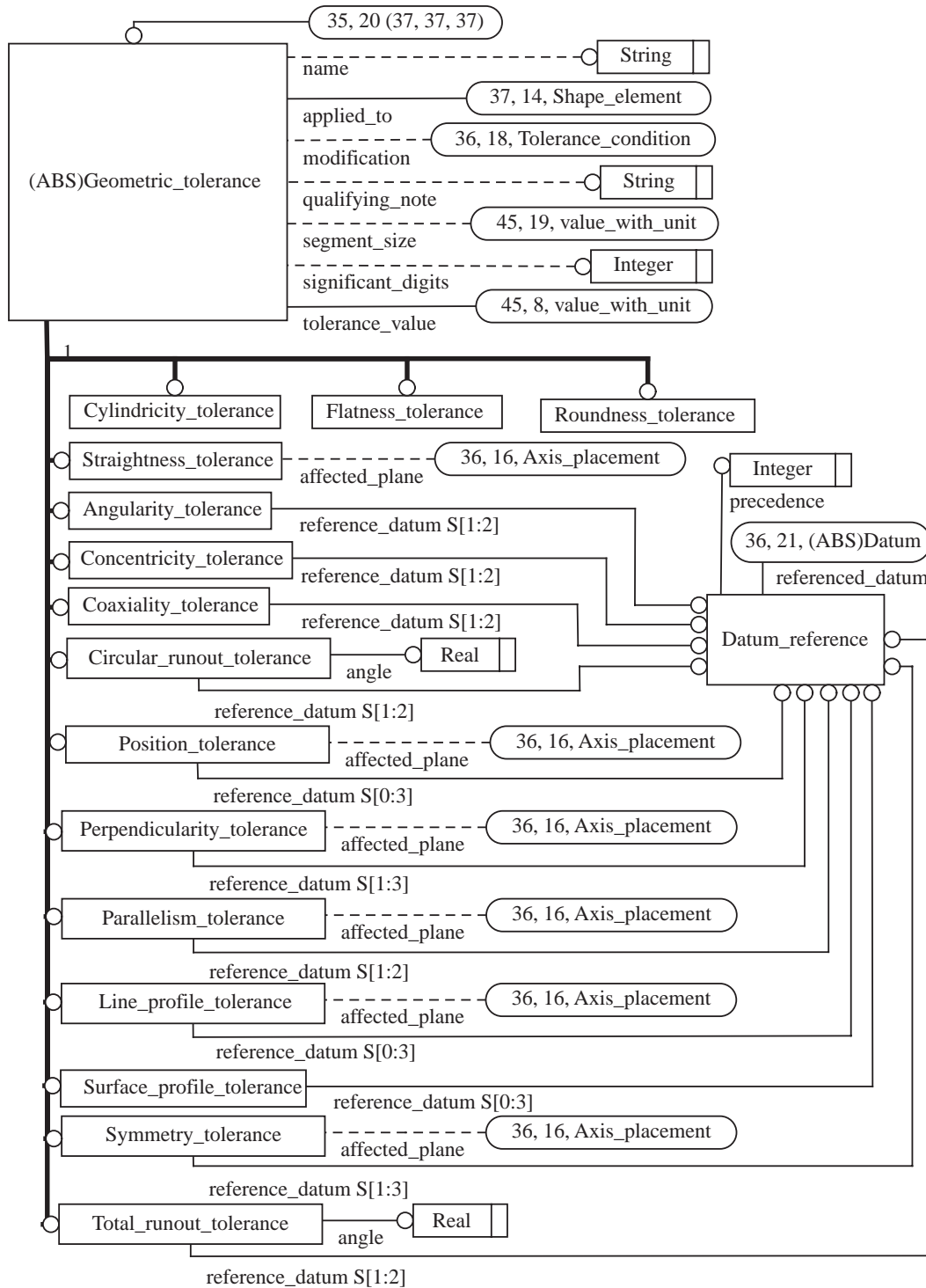
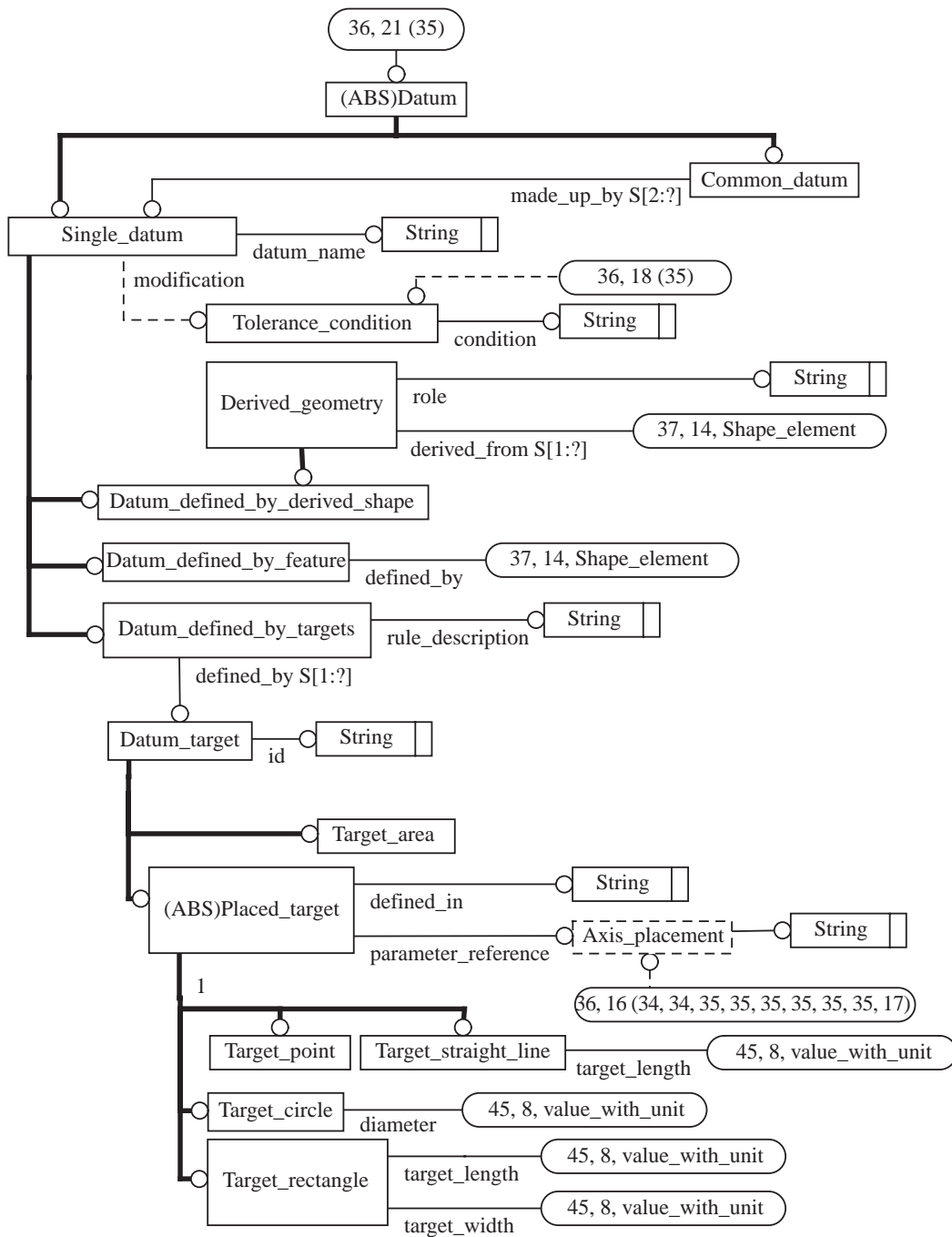


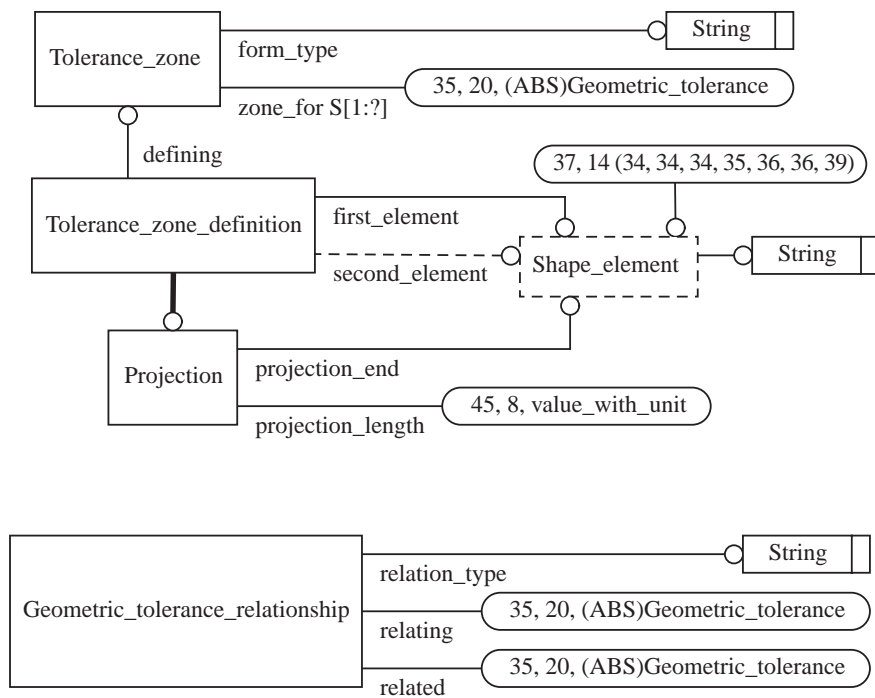
Figure G.34 — ARM diagram (34 of 48)



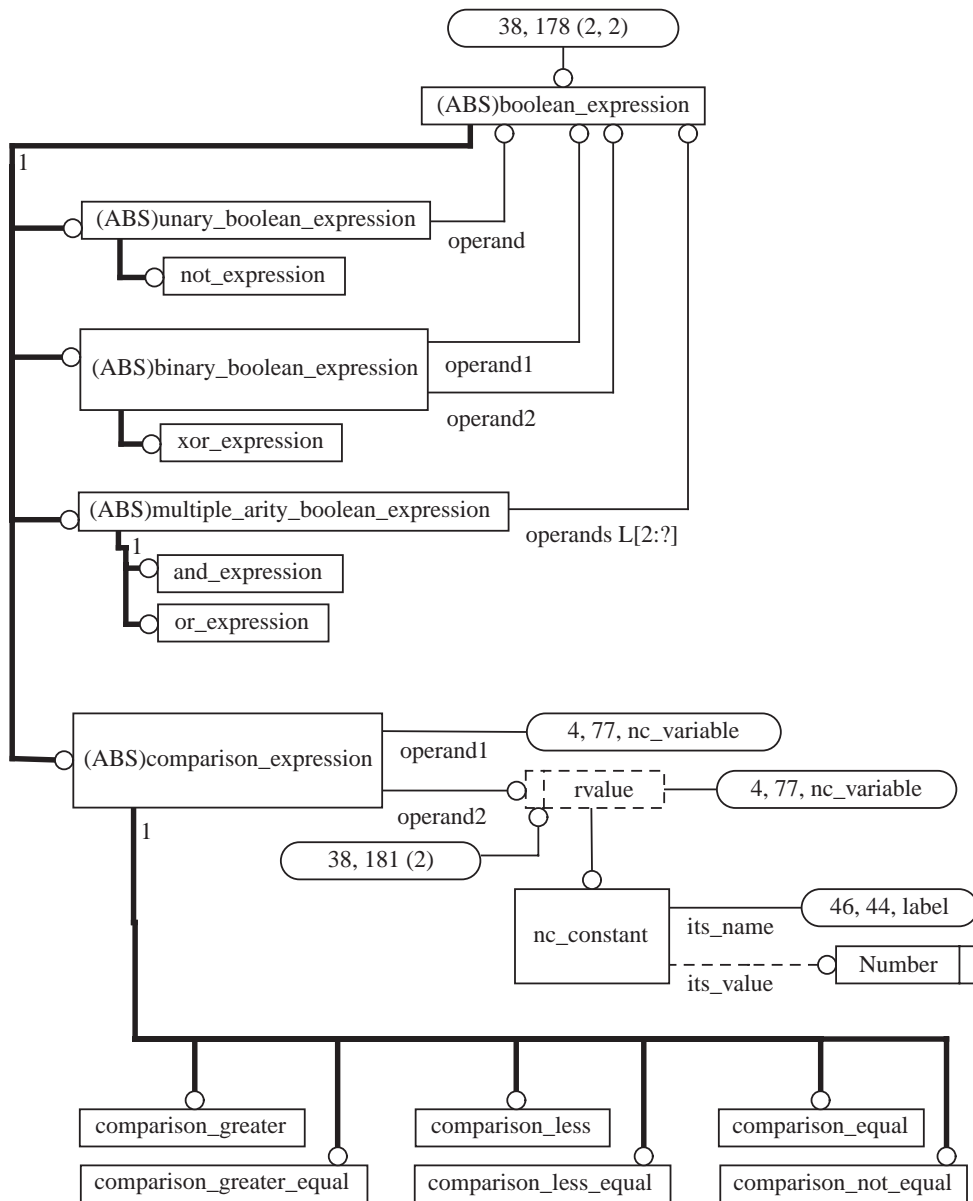
**Figure G.35 — ARM diagram (35 of 48)**



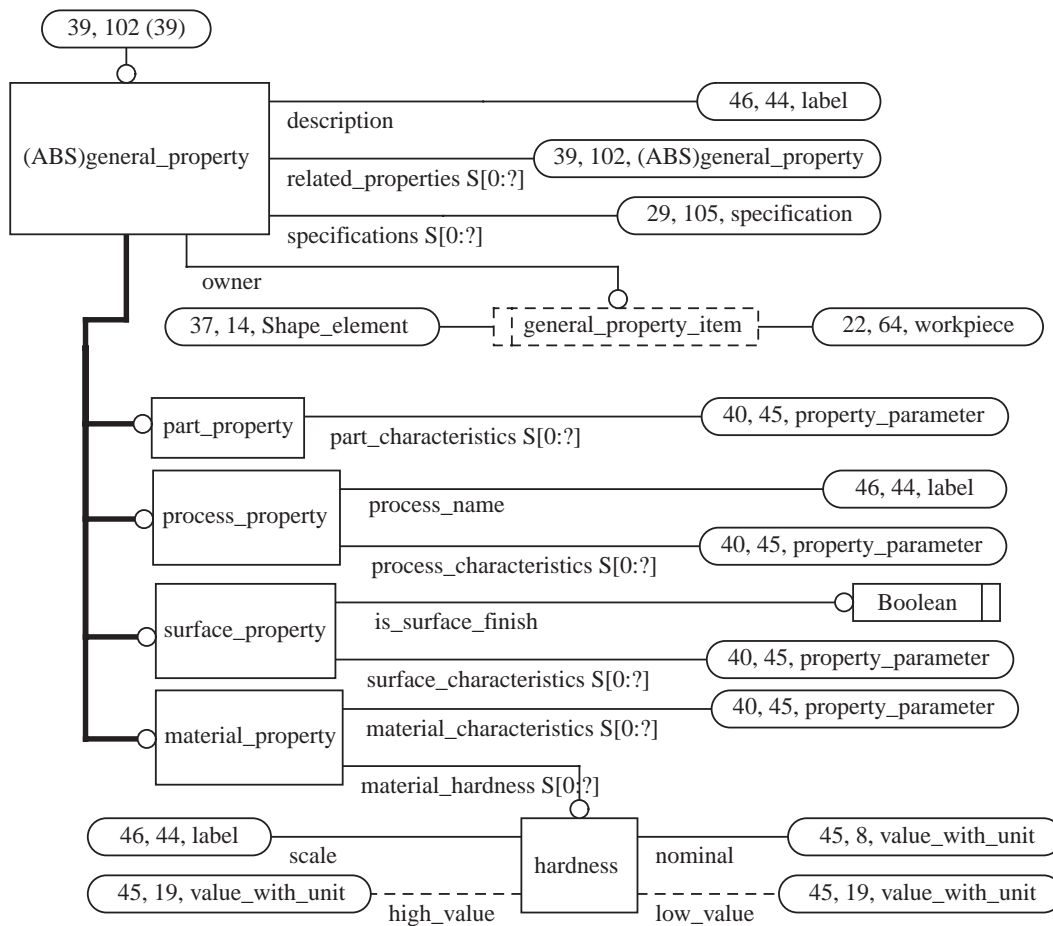
**Figure G.36 — ARM diagram (36 of 48)**



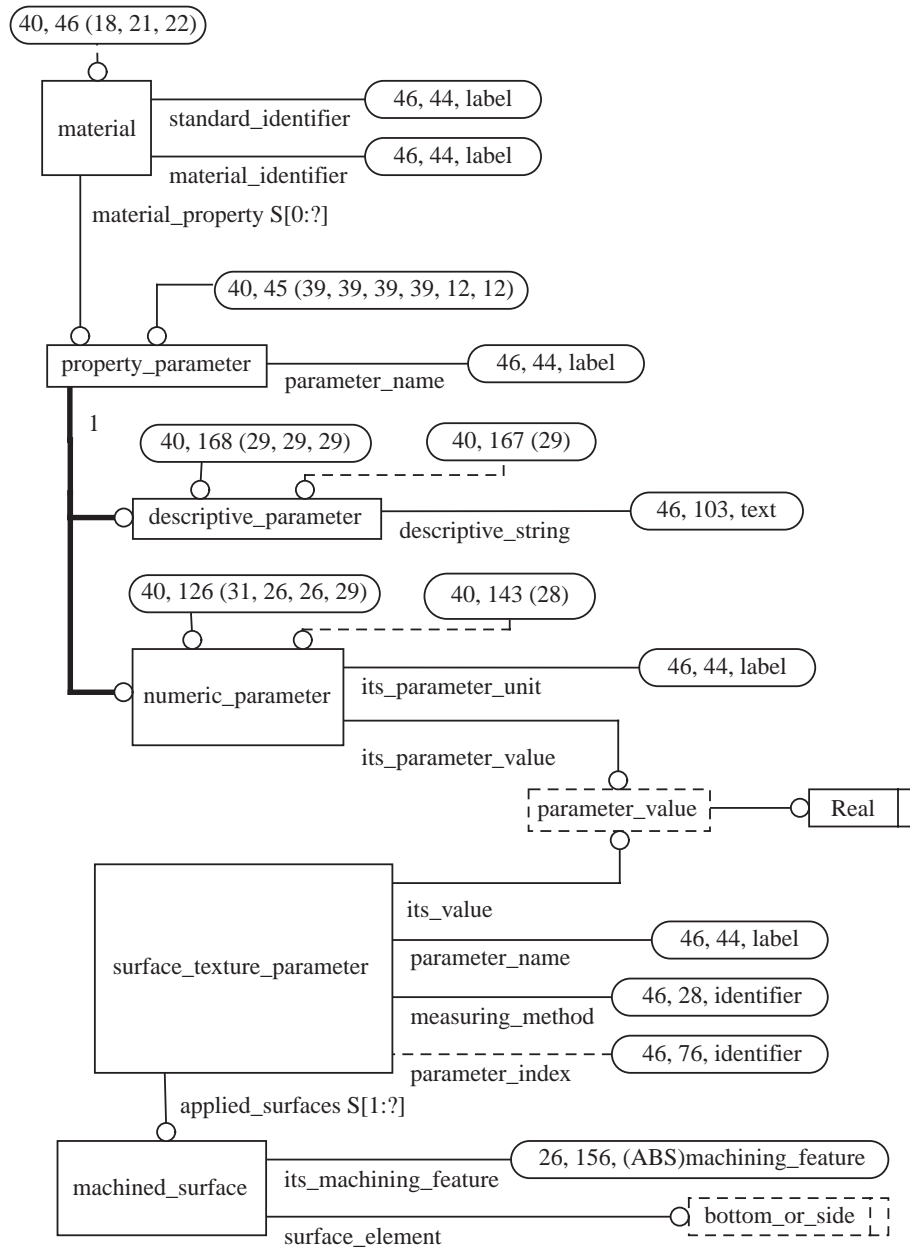
**Figure G.37 — ARM diagram (37 of 48)**



**Figure G.38 — ARM diagram (38 of 48)**

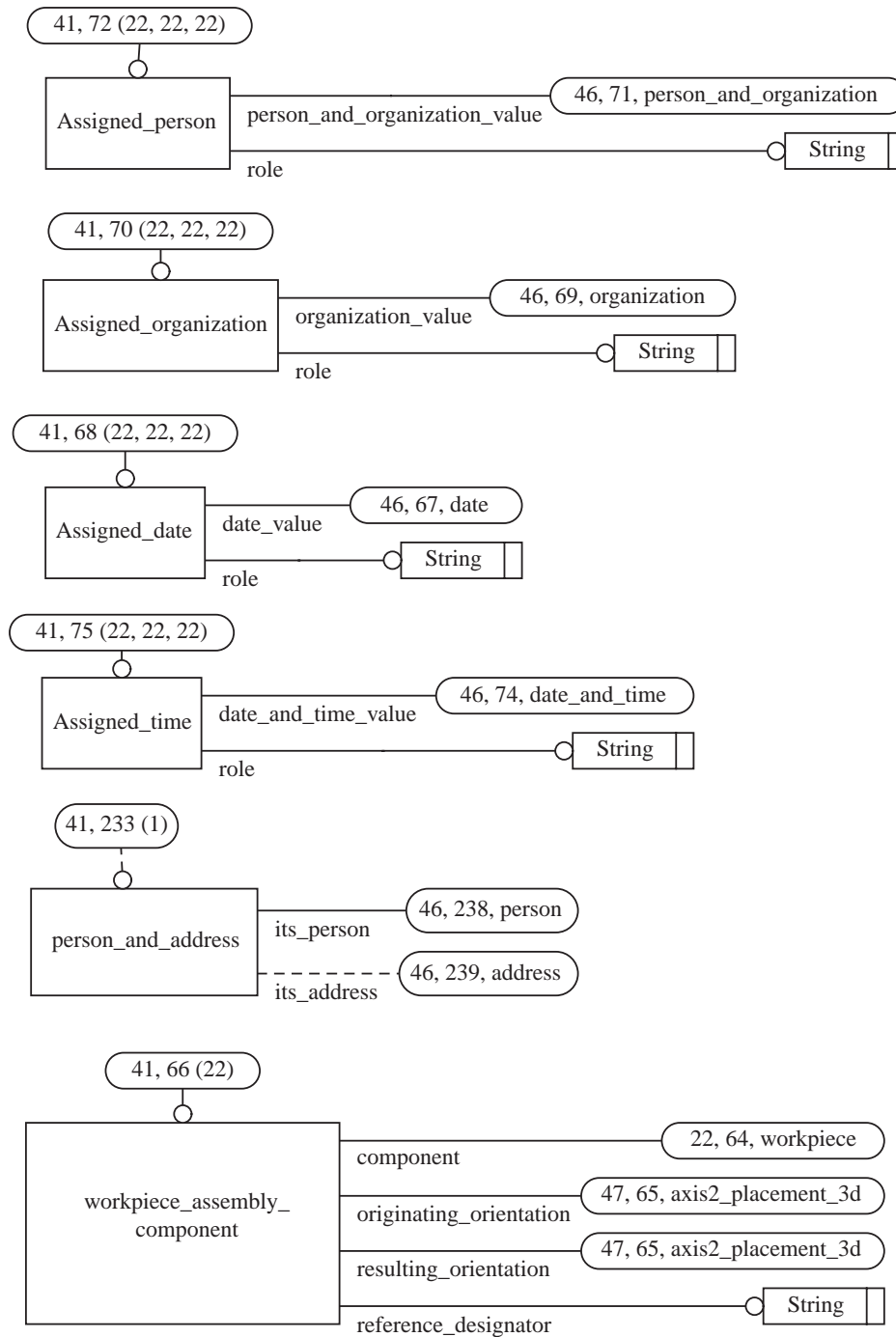


**Figure G.39 — ARM diagram (39 of 48)**

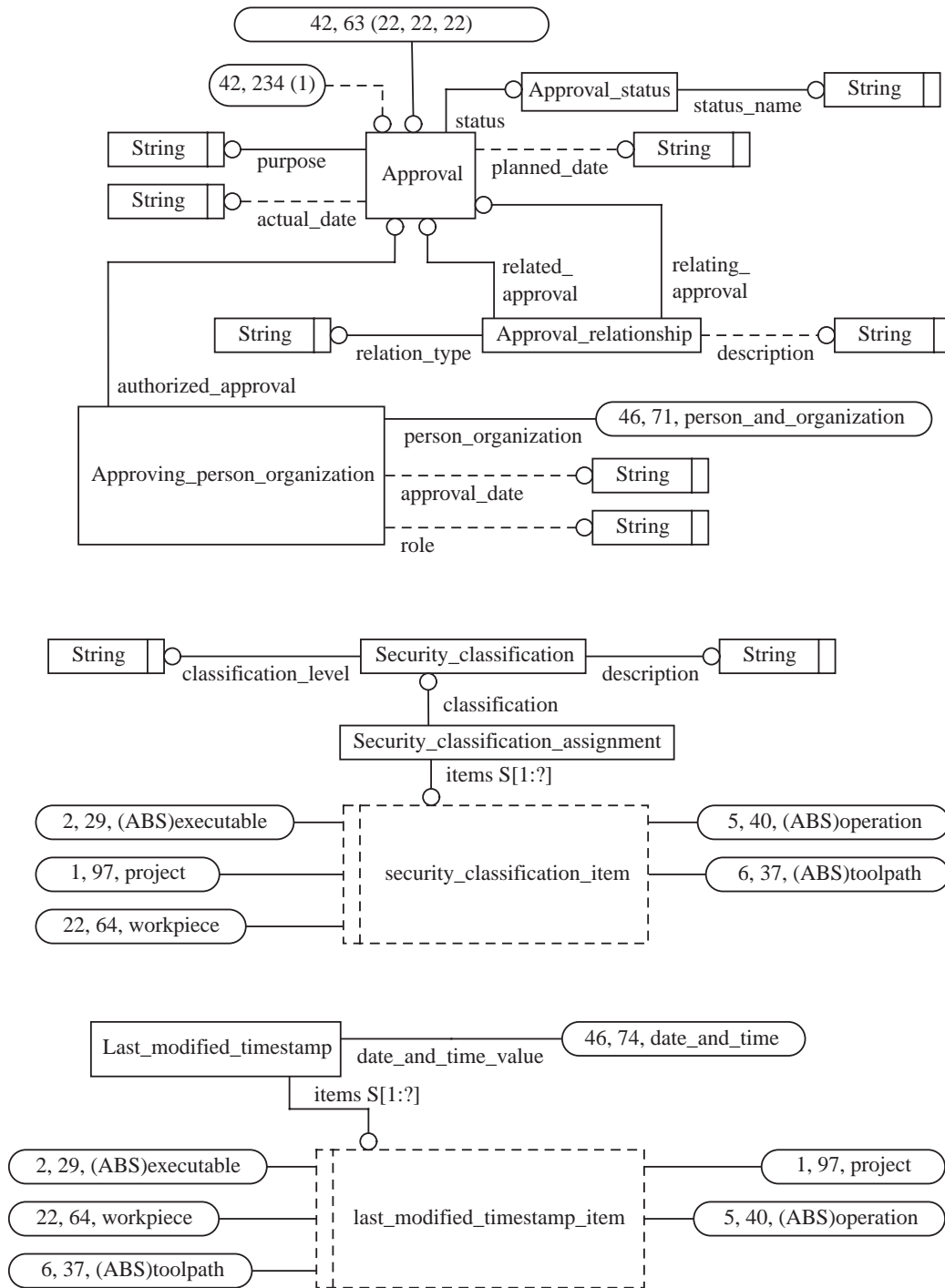


**Figure G.40 — ARM diagram (40 of 48)**

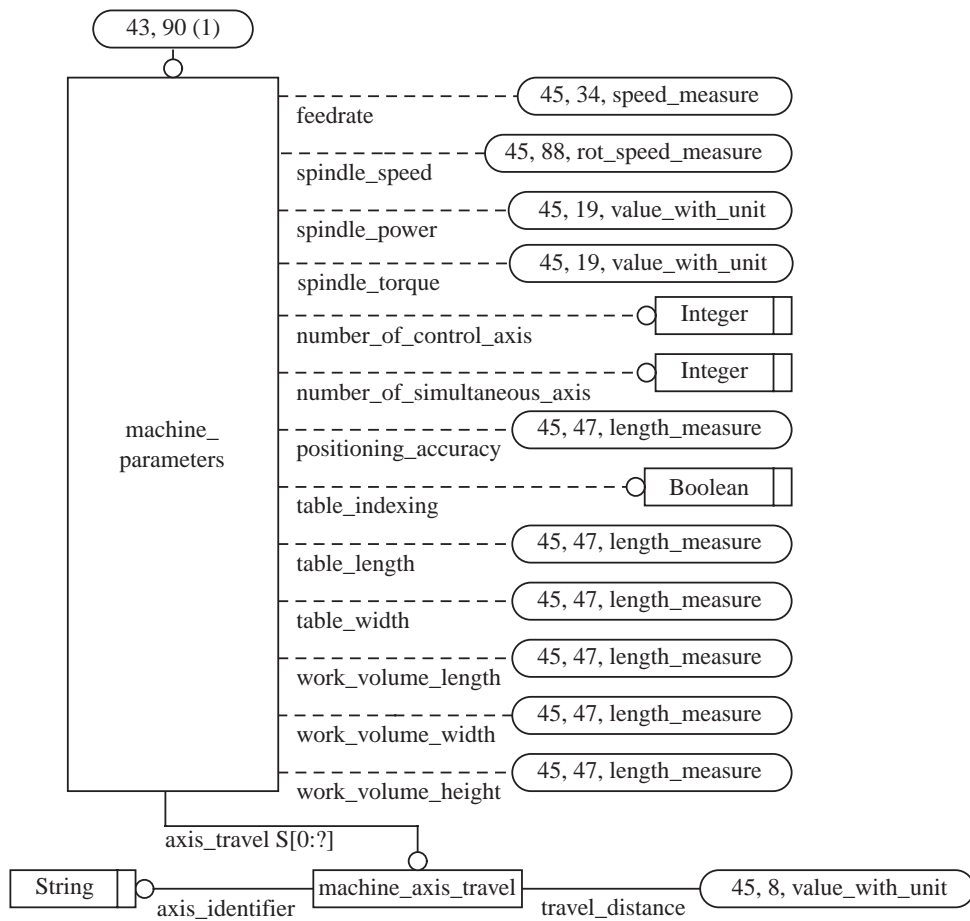




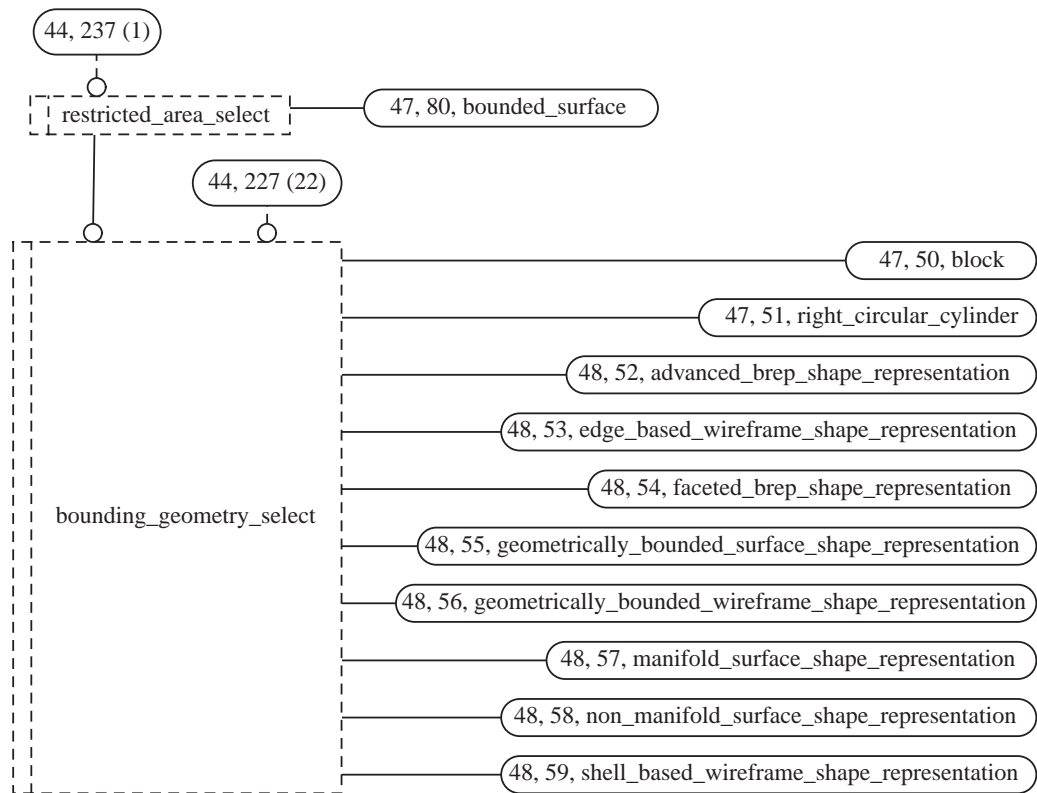
**Figure G.41 — ARM diagram (41 of 48)**



**Figure G.42 — ARM diagram (42 of 48)**



**Figure G.43 — ARM diagram (43 of 48)**



**Figure G.44 — ARM diagram (44 of 48)**

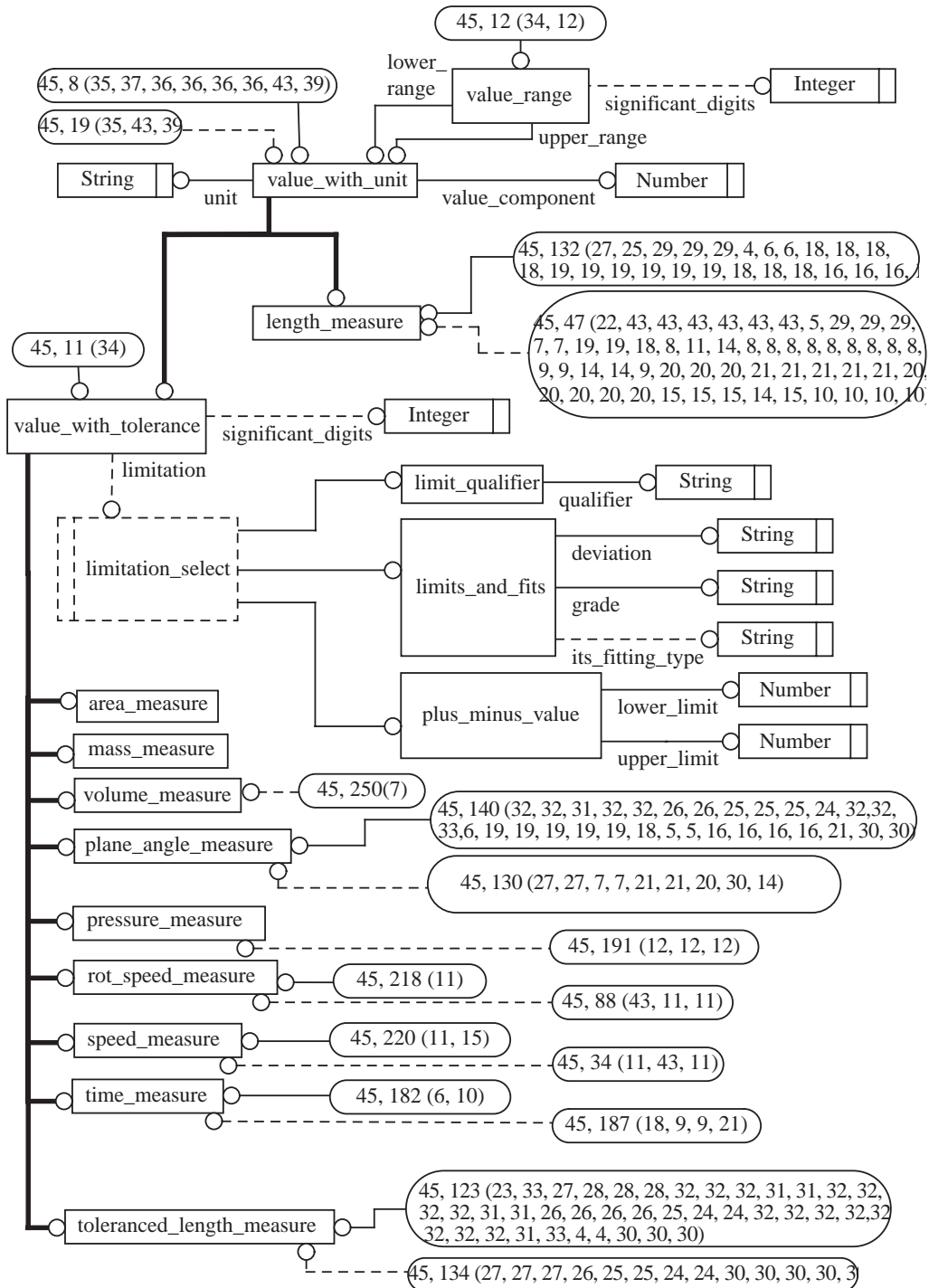
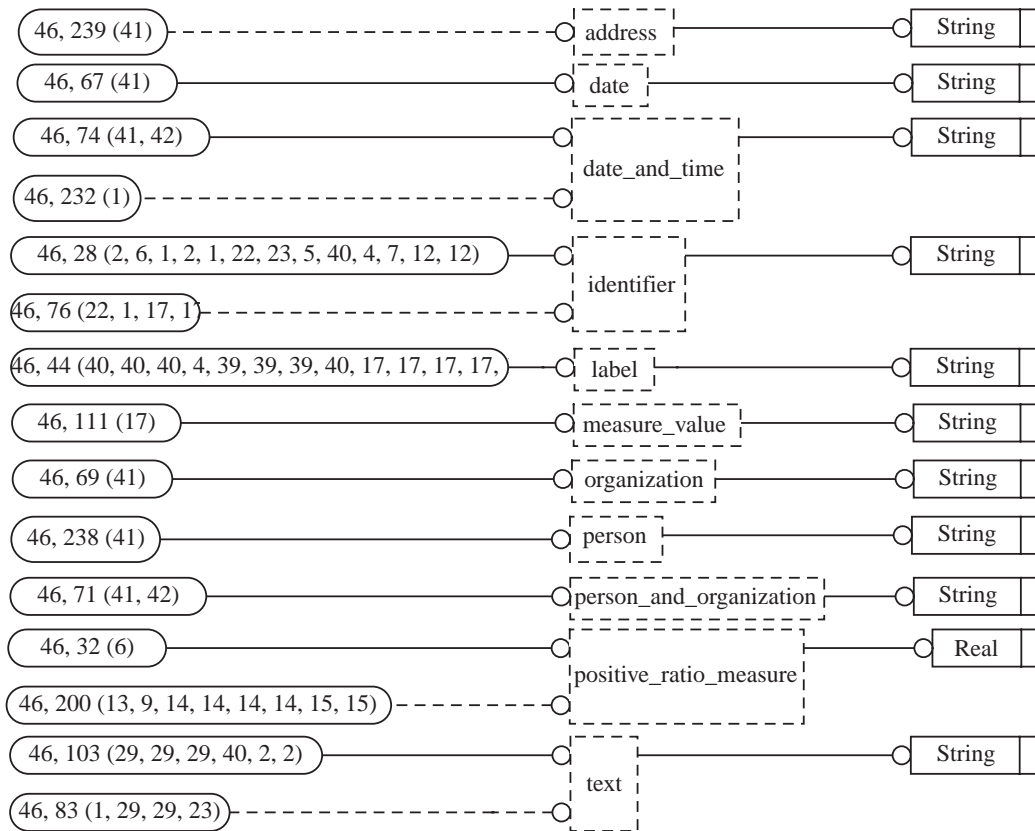
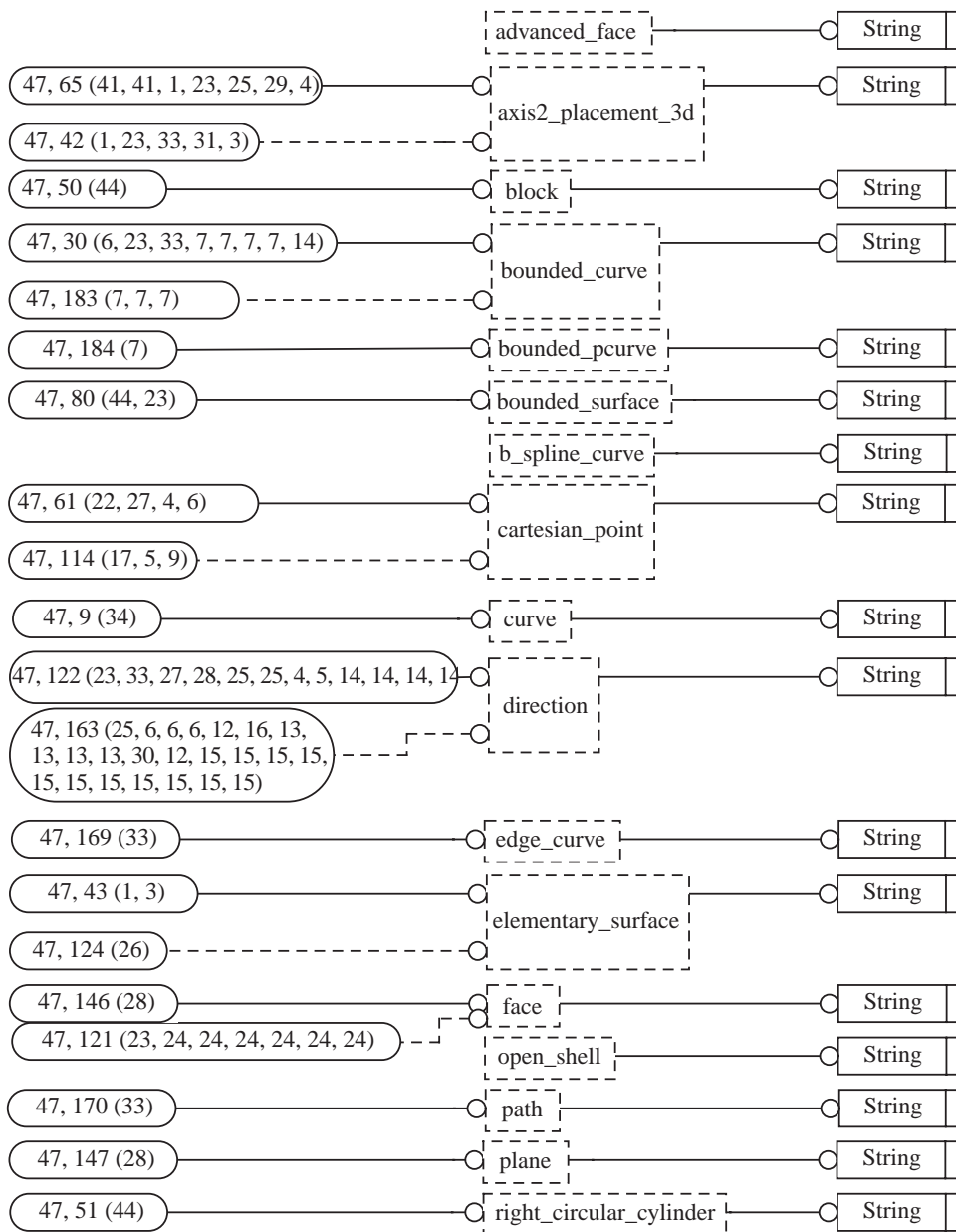


Figure G.45 — ARM diagram (45 of 48)



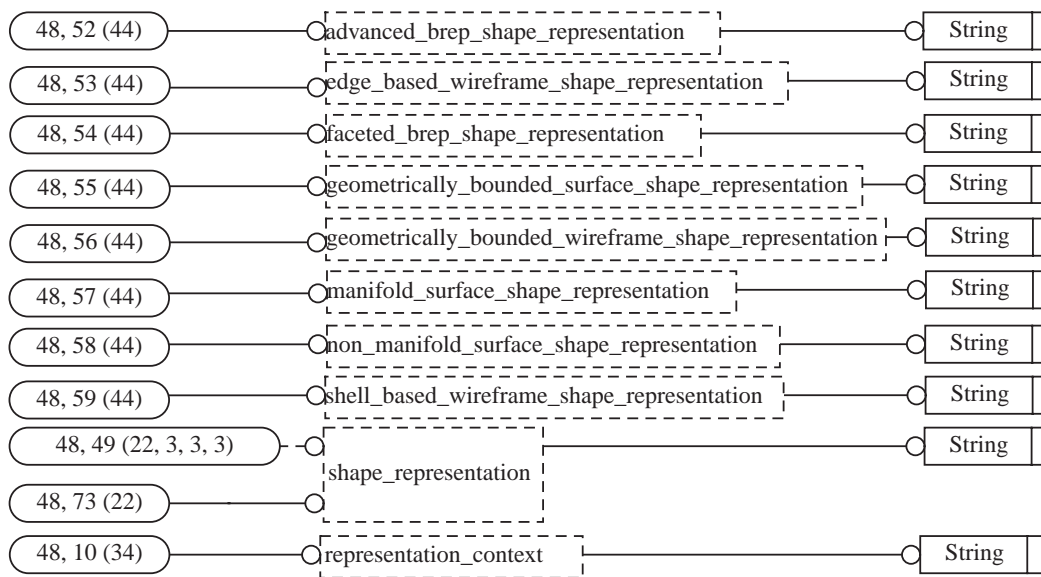
NOTE These are integrated resource definitions referenced by ISO 14649 but defined in ISO 10303-41. For the purposes of this application reference model these are treated as primitive types.

**Figure G.46 — ARM diagram (46 of 48)**



NOTE These are integrated resource definitions referenced by ISO 14649 but defined in ISO 10303-42. For the purposes of this application reference model these are treated as primitive types.

**Figure G.47 — ARM diagram (47 of 48)**



NOTE These are integrated resource definitions referenced by ISO 14649 but defined in AICs and other integrated resource parts. For the purposes of this application reference model these are treated as primitive types.

**Figure G.48 — ARM diagram (48 of 48)**

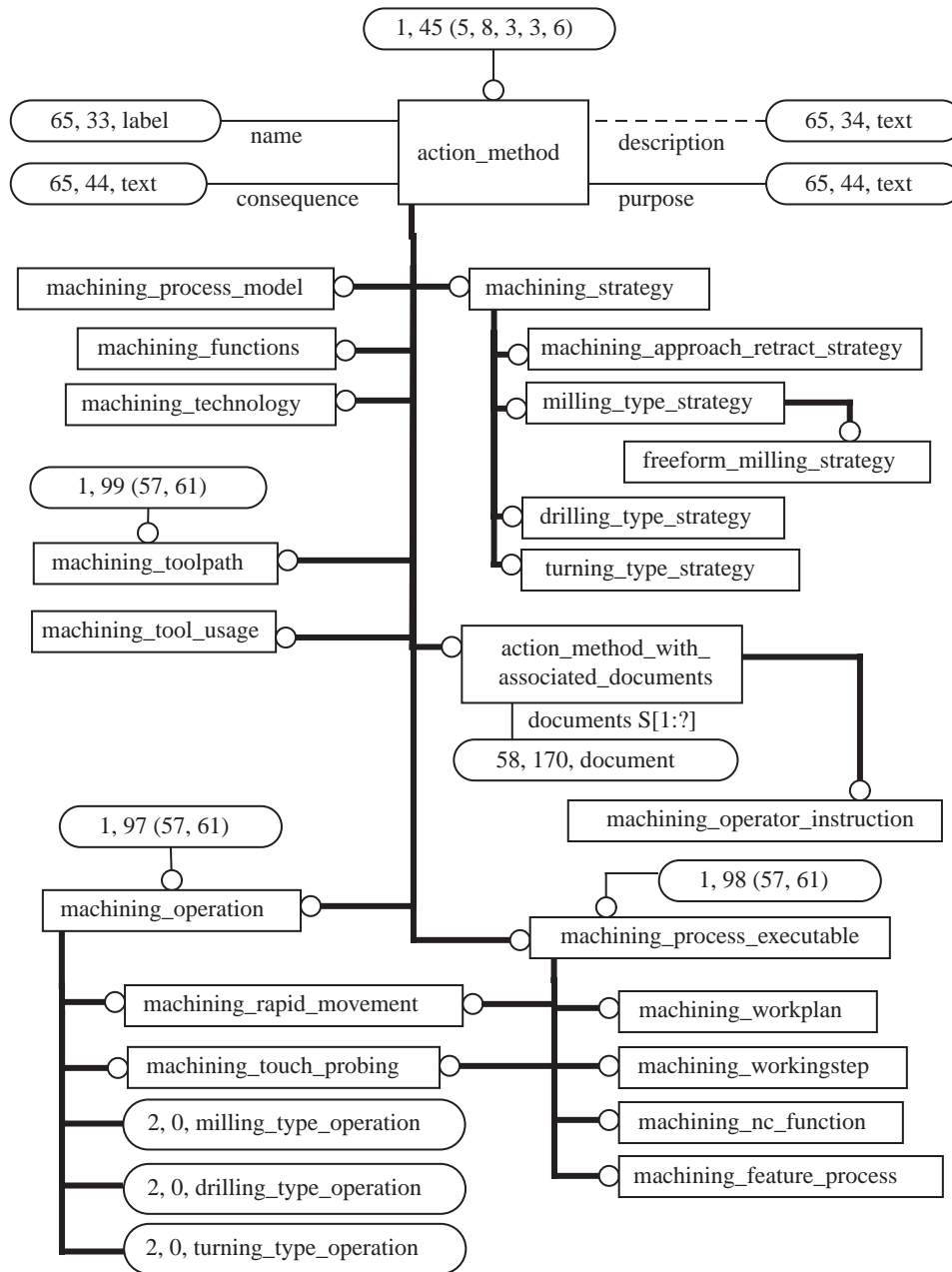


[Blank page]

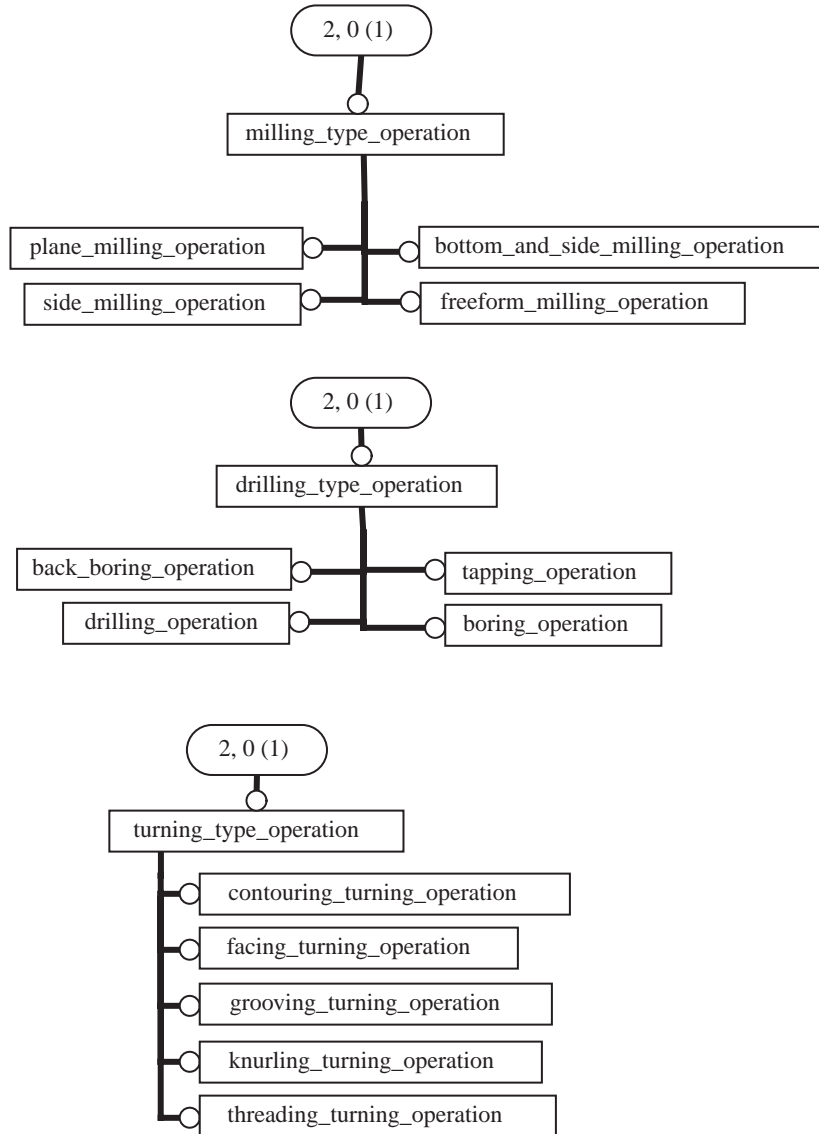
**Annex H**  
(informative)

**AIM EXPRESS-G**

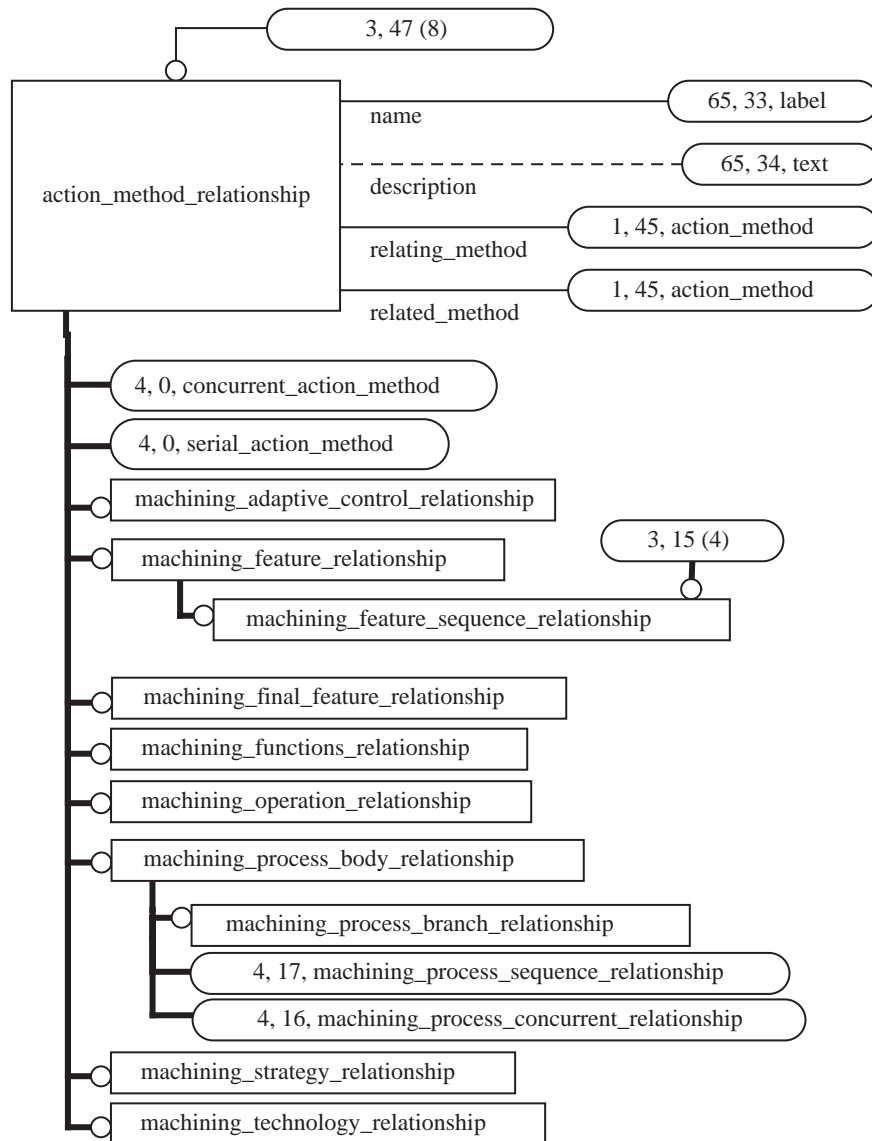
The diagrams in this annex correspond to the AIM EXPRESS expanded listing given in Annex A. The diagrams use the EXPRESS-G graphical notation for the EXPRESS language. EXPRESS-G is defined in Annex D of ISO 10303-11:1994.



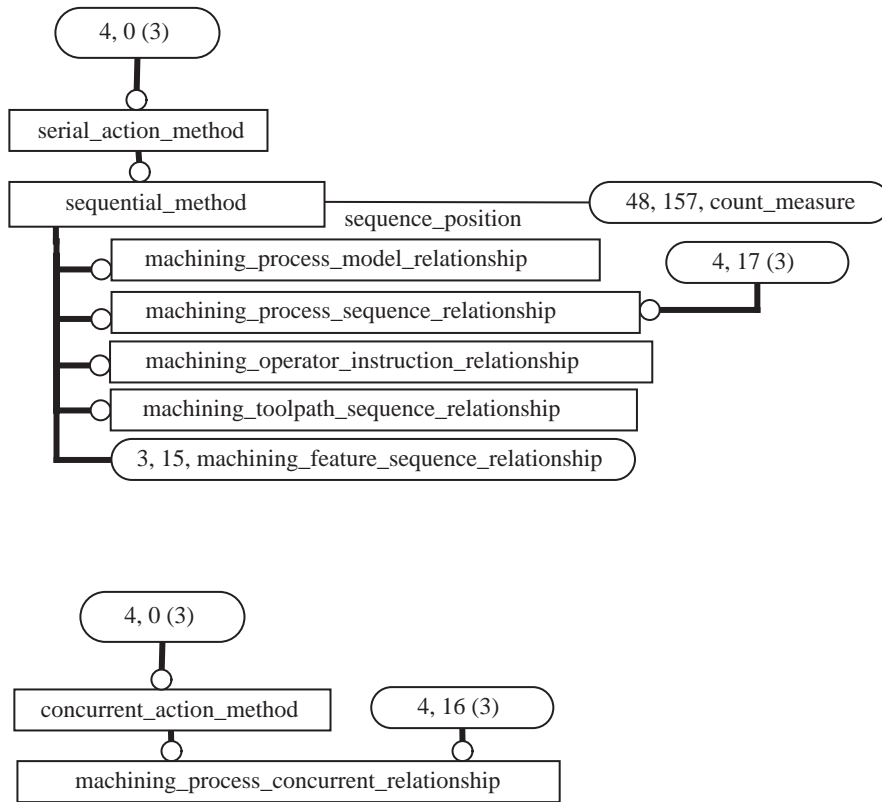
**Figure H.1 — AIM EXPRESS-G diagram action method**



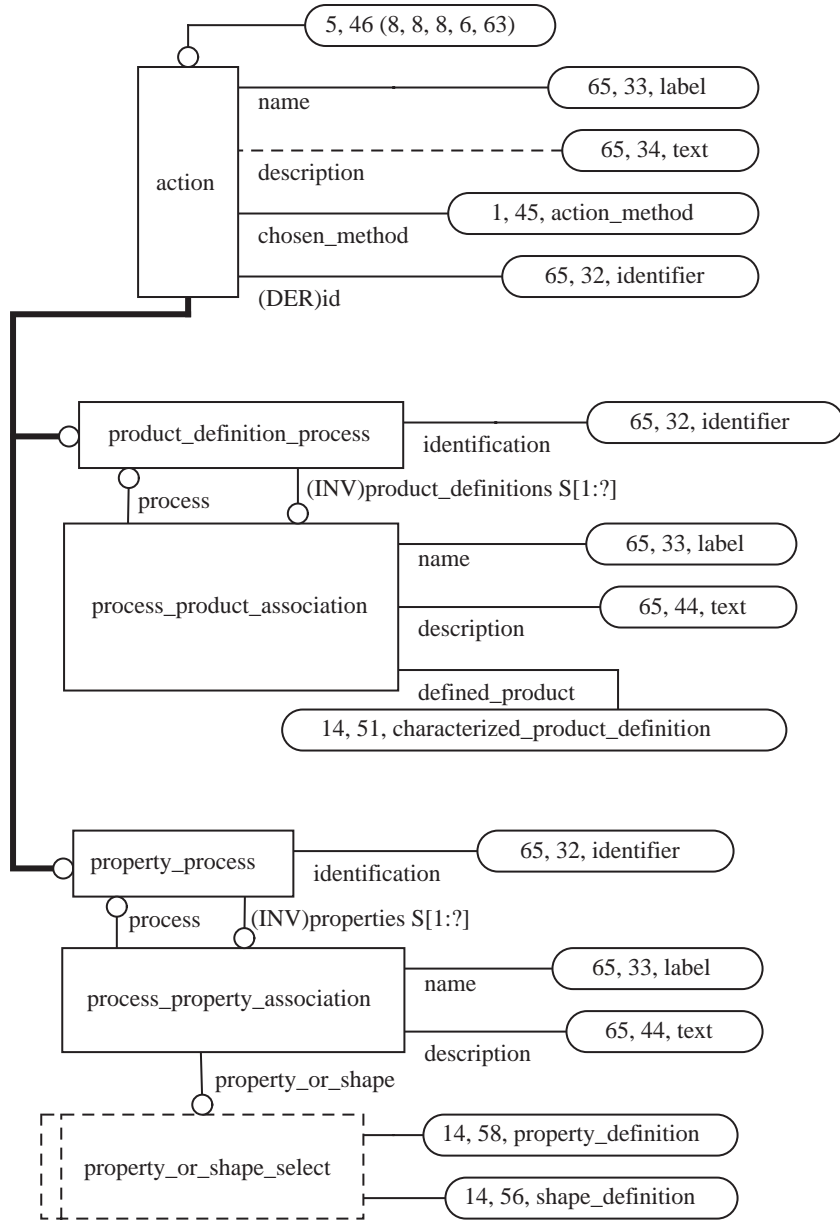
**Figure H.2 — AIM EXPRESS-G diagram machining operation subtypes**



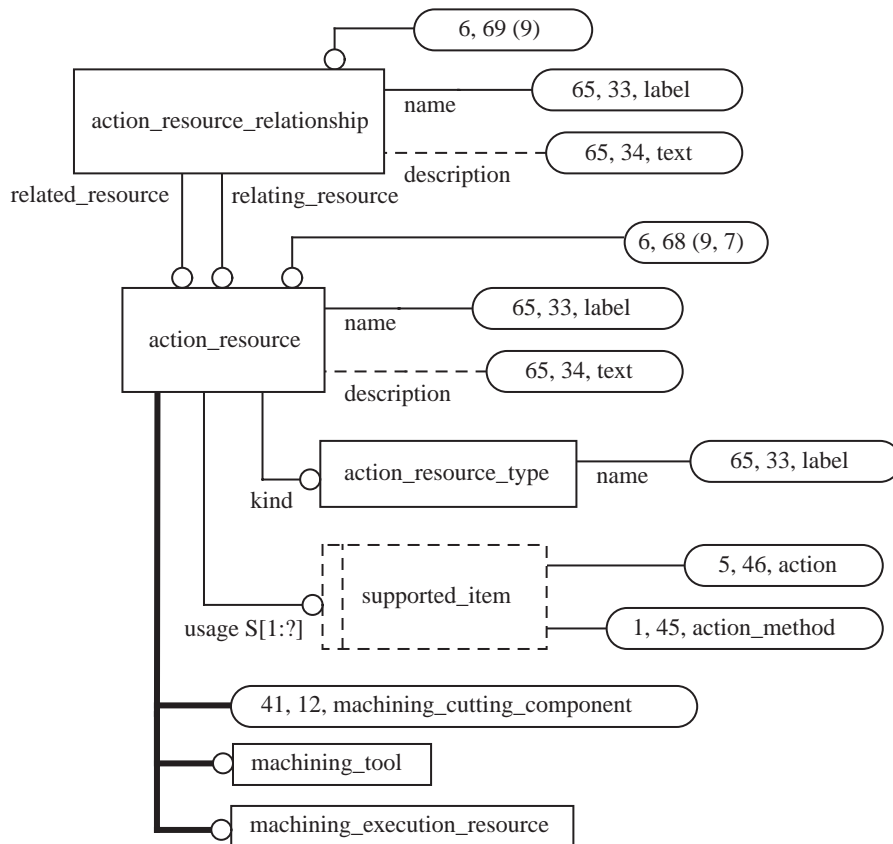
**Figure H.3 — AIM EXPRESS-G diagram action method relationship**



**Figure H.4 — AIM EXPRESS-G diagram action method relationship subtypes**

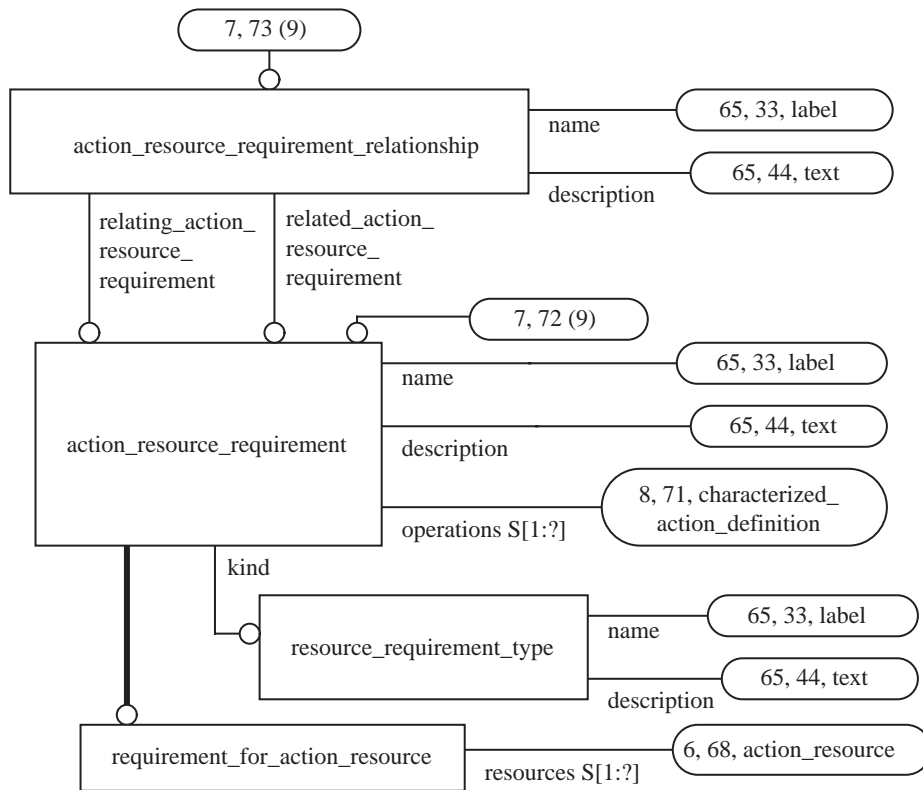


**Figure H.5 — AIM EXPRESS-G diagram action**

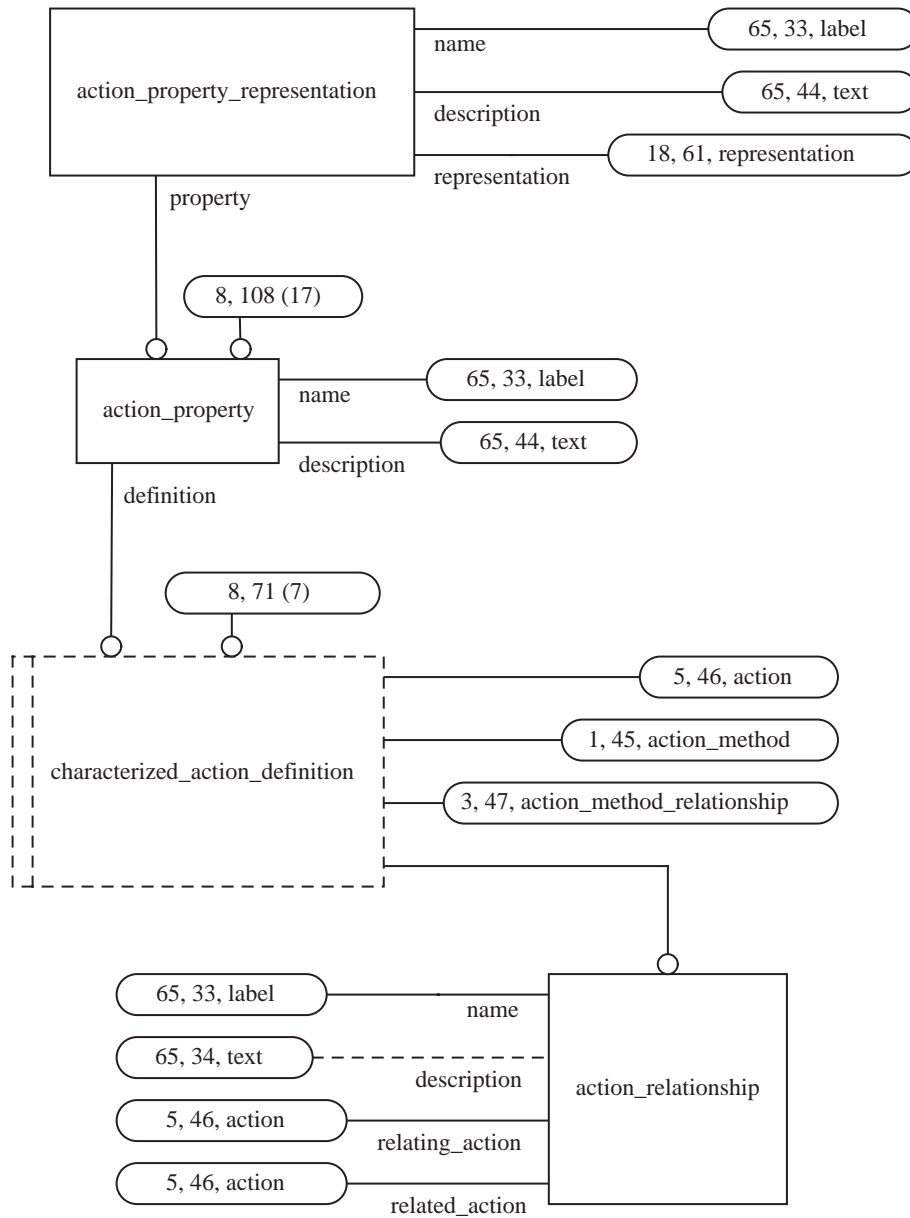


**Figure H.6 — AIM EXPRESS-G diagram action resource**

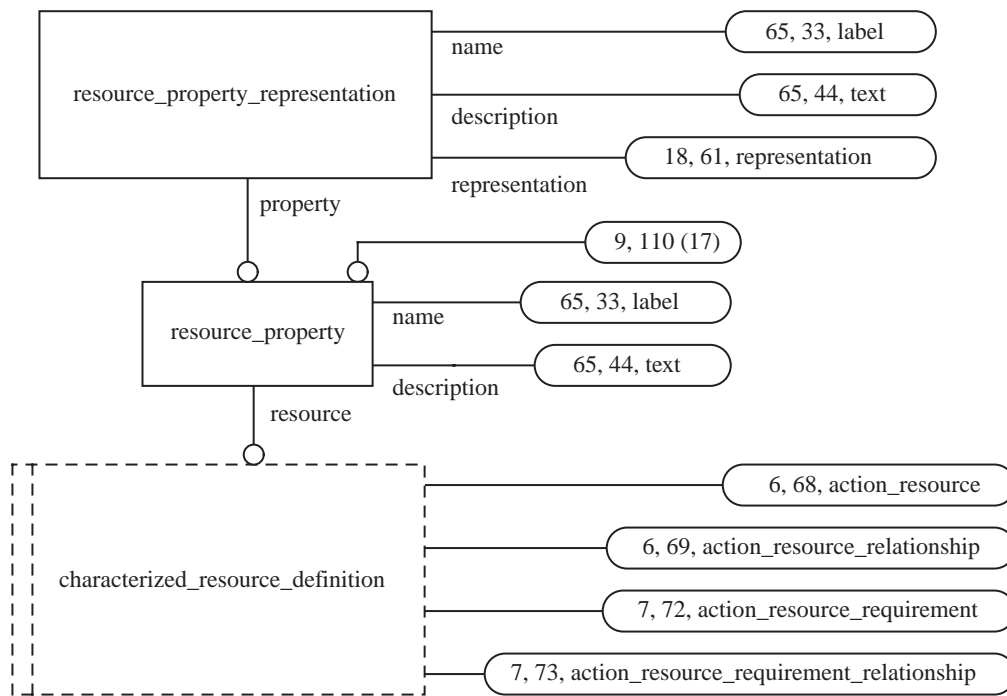




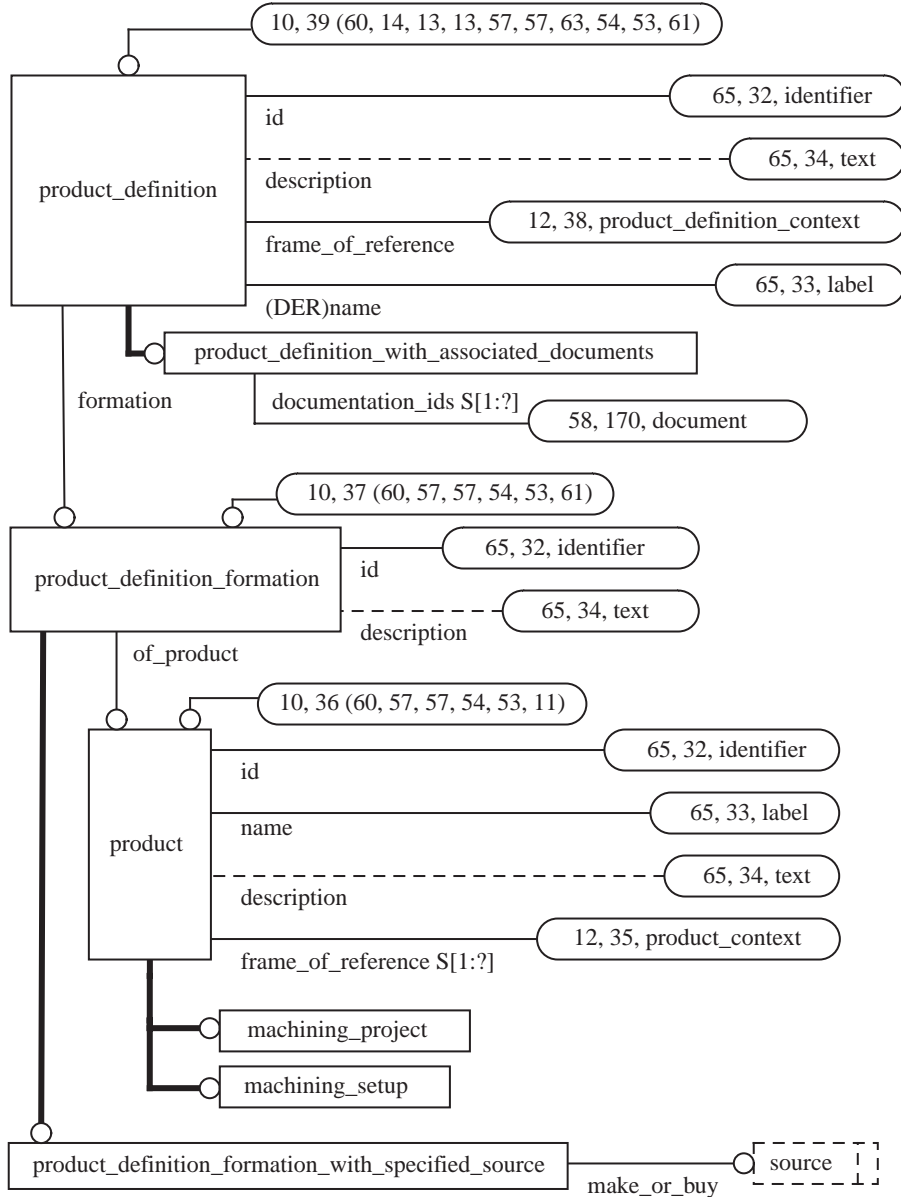
**Figure H.7 — AIM EXPRESS-G diagram action resource requirement**



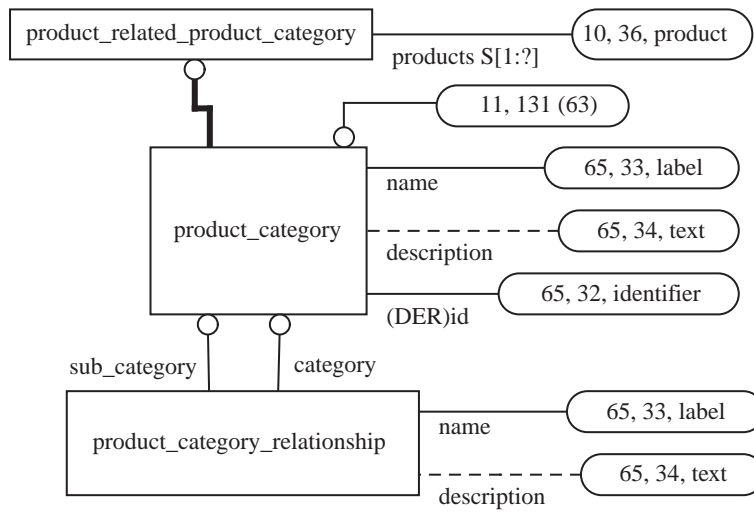
**Figure H.8 — AIM EXPRESS-G diagram action property**



**Figure H.9 — AIM EXPRESS-G diagram resource property**



**Figure H.10 — AIM EXPRESS-G diagram product**



**Figure H.11 — AIM EXPRESS-G diagram product category**

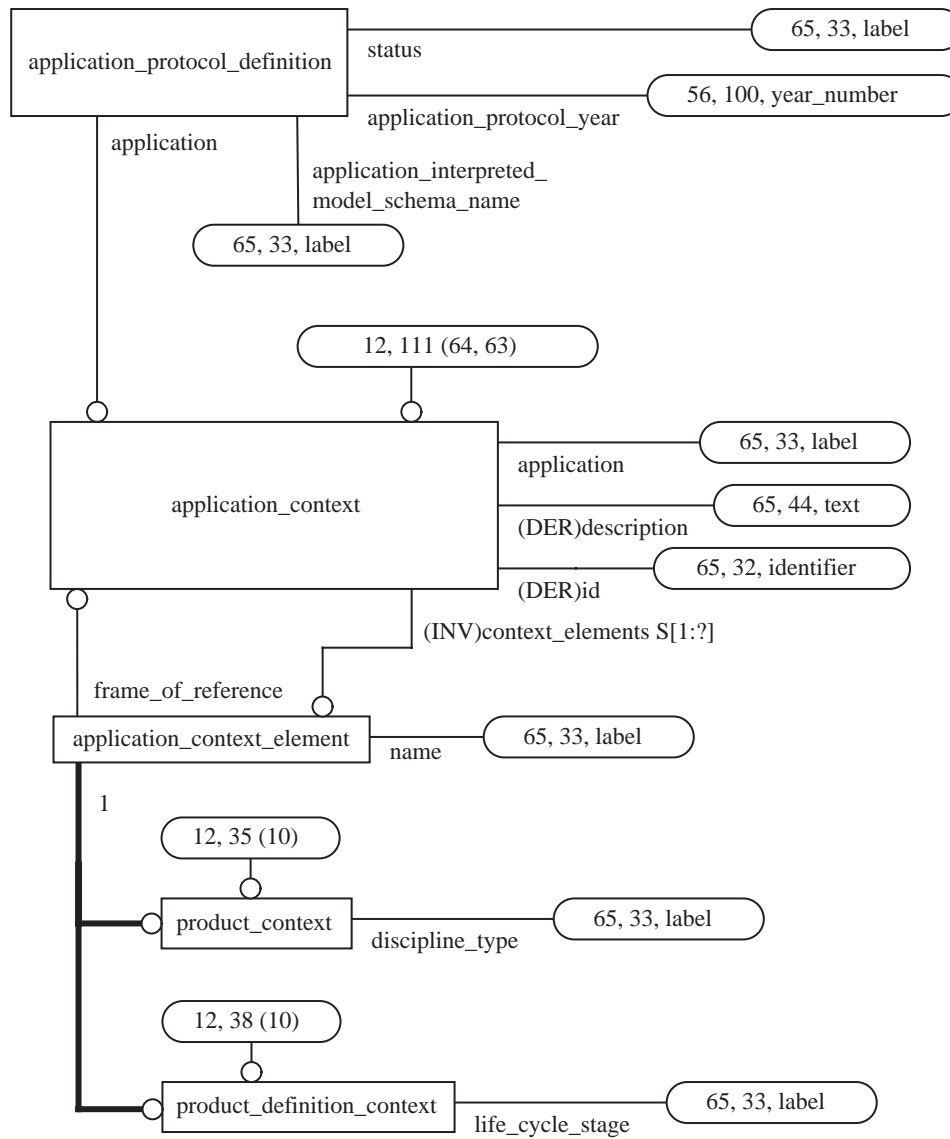
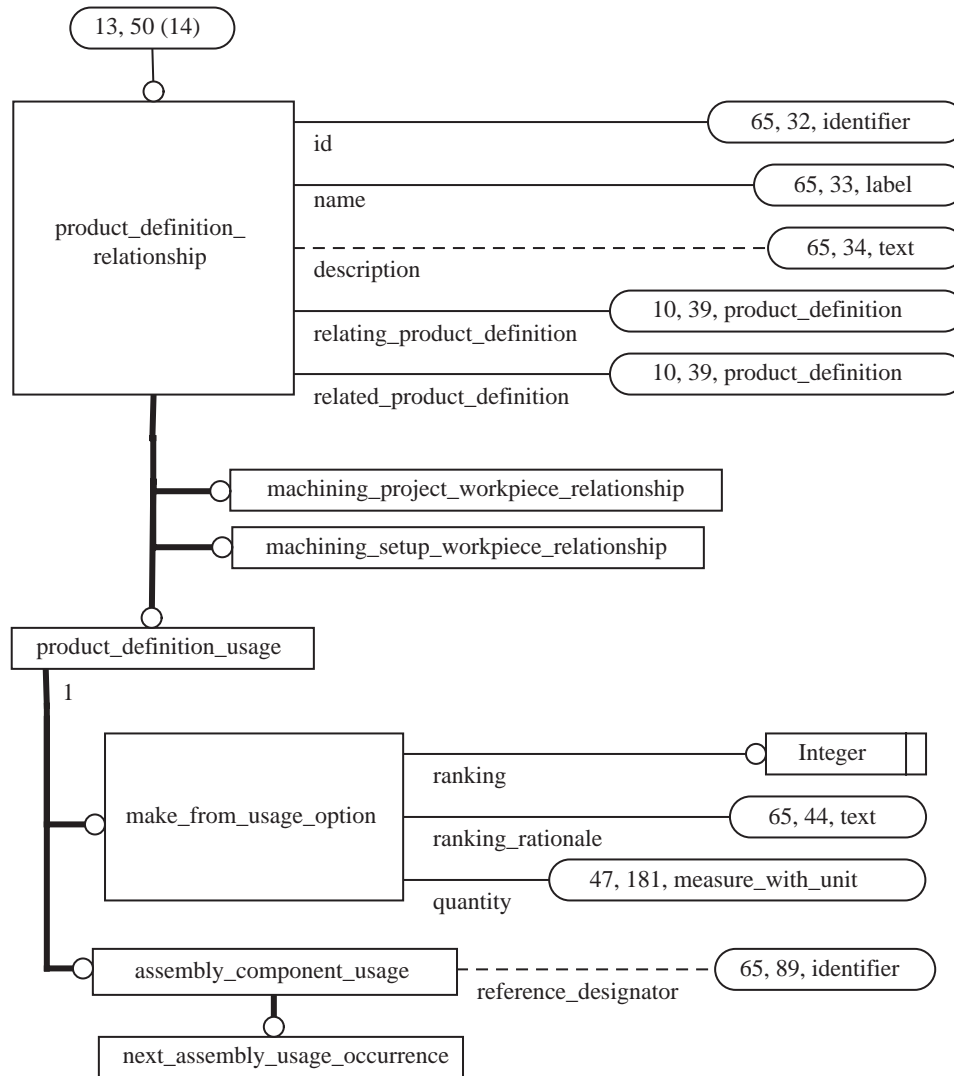


Figure H.12 — AIM EXPRESS-G diagram product context



**Figure H.13 — AIM EXPRESS-G diagram product definition relationship**

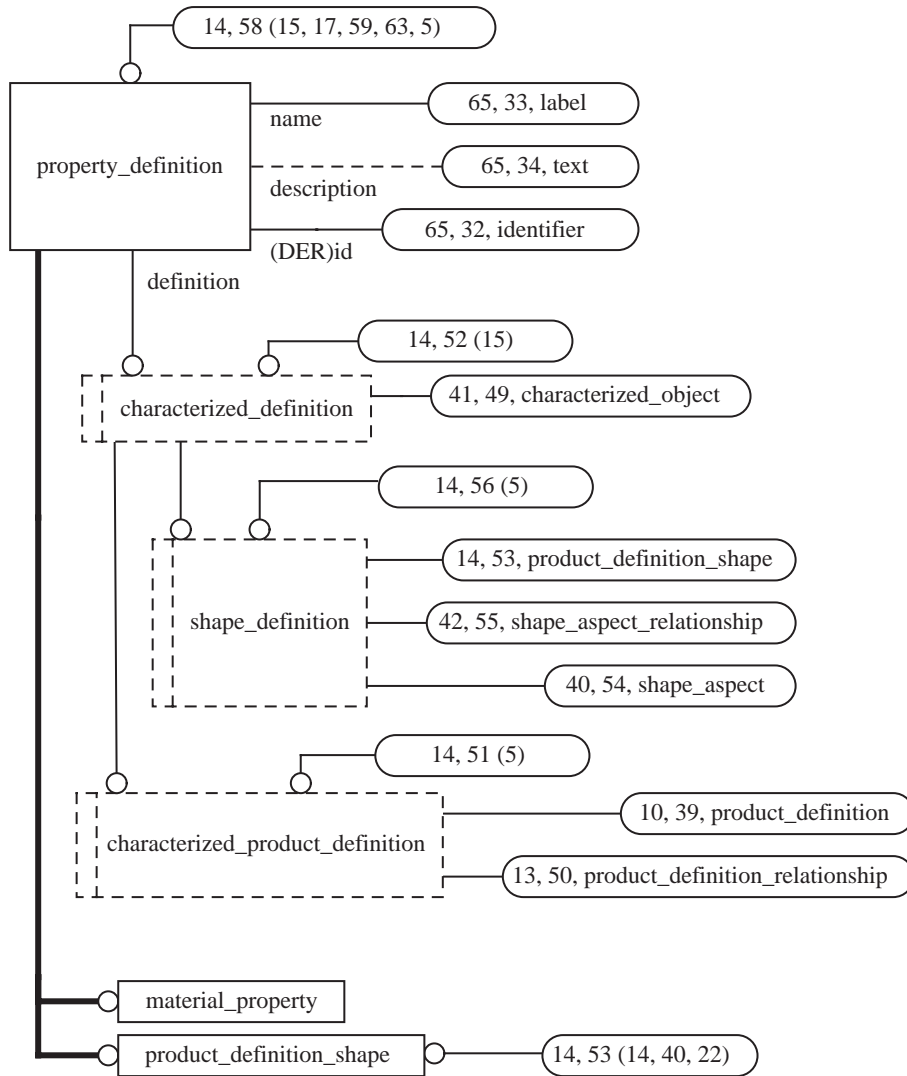
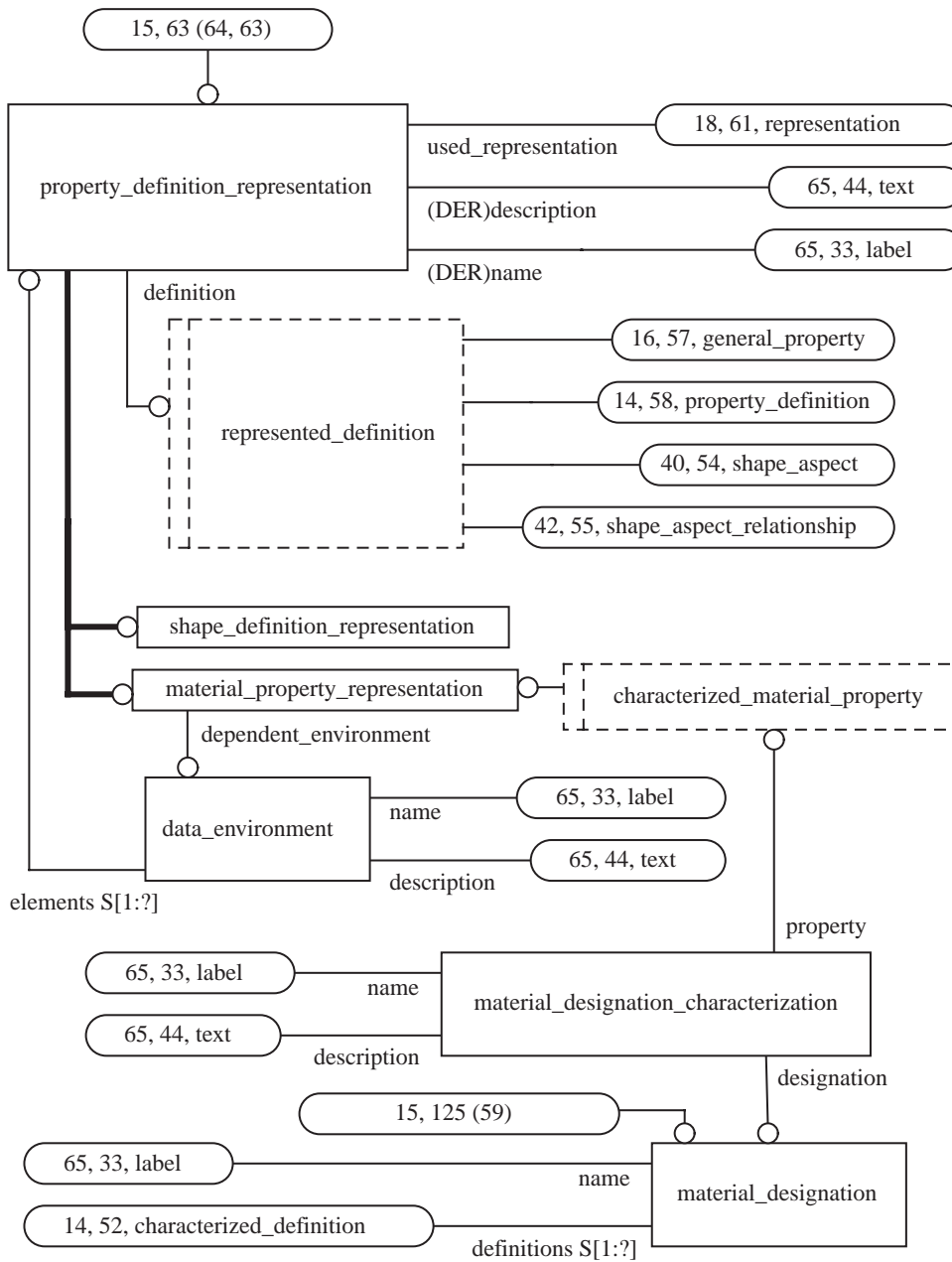
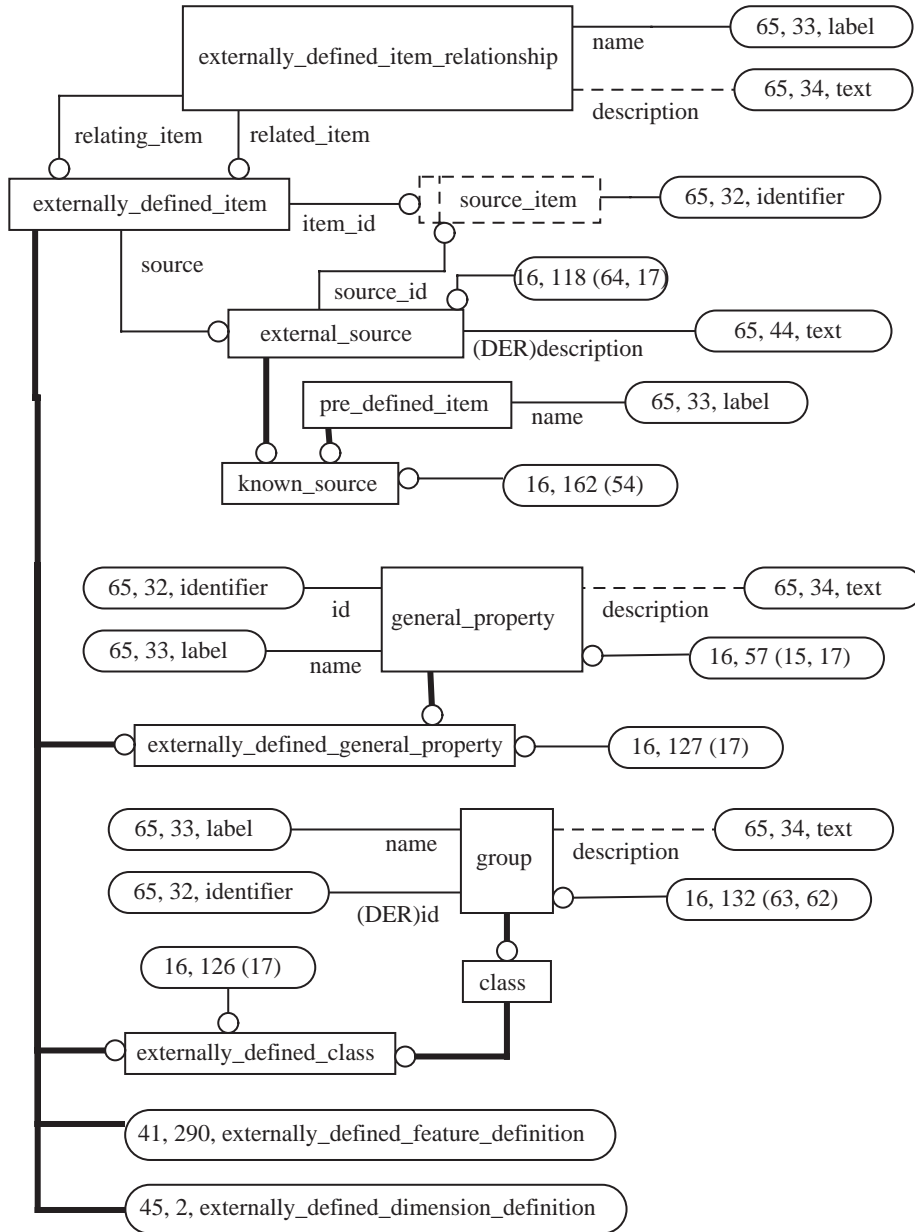


Figure H.14 — AIM EXPRESS-G diagram property definition

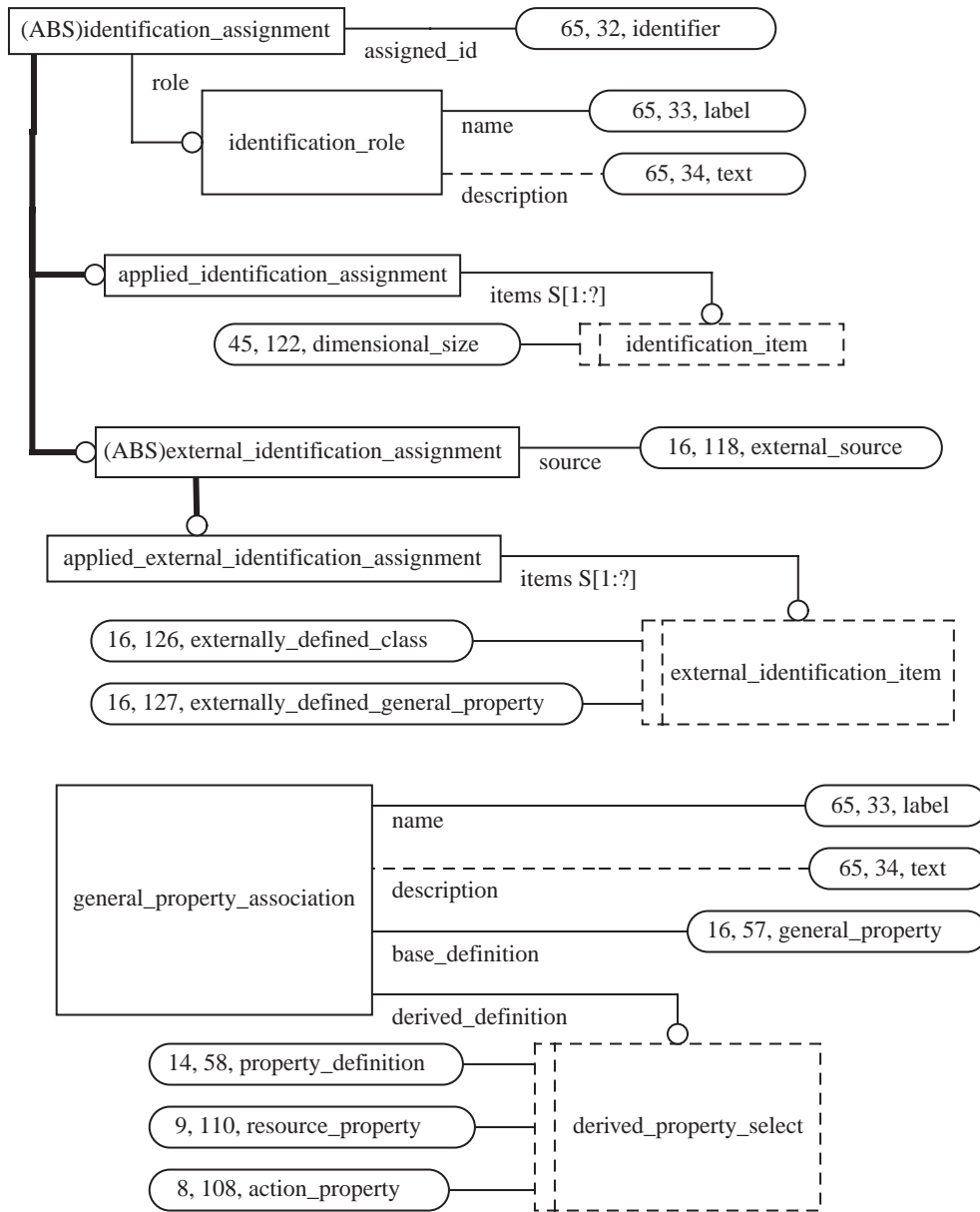




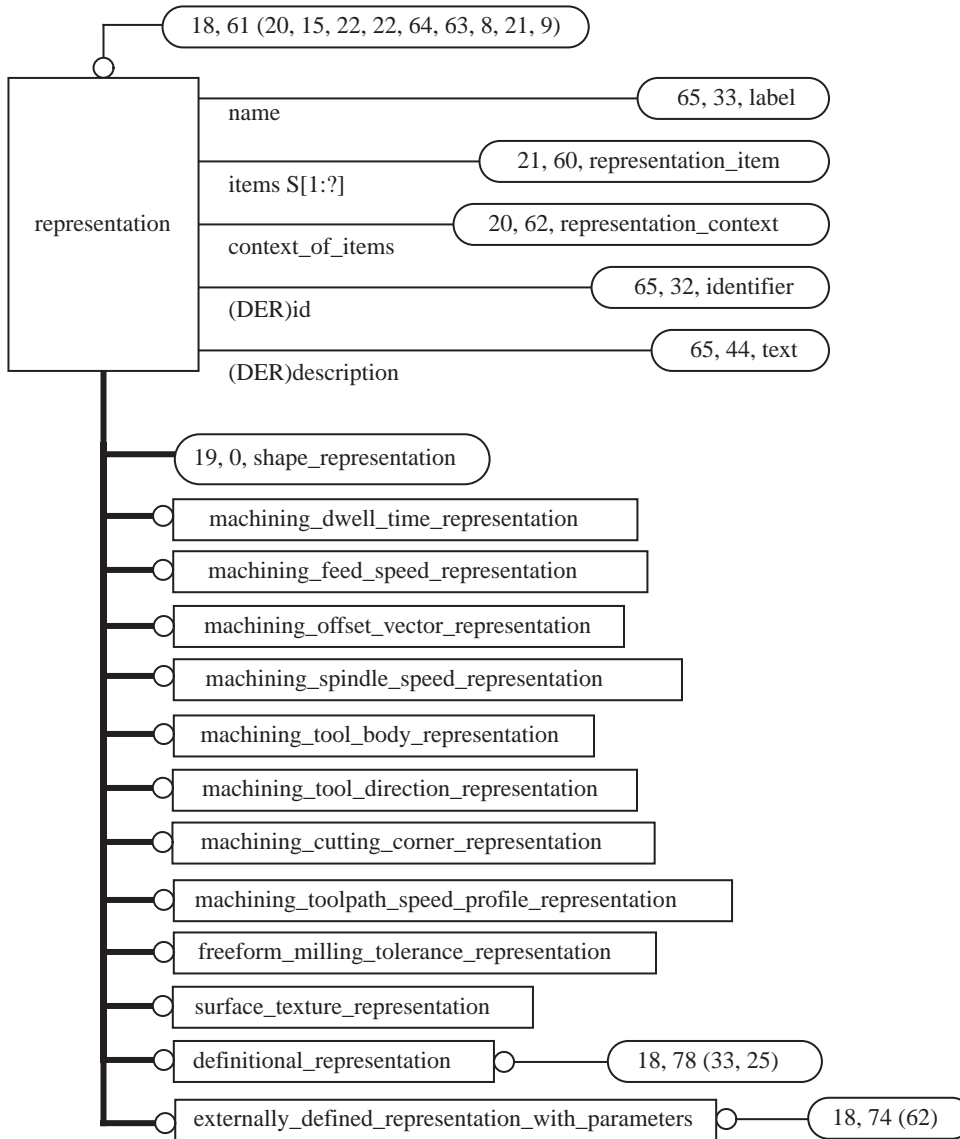
**Figure H.15 — AIM EXPRESS-G diagram property definition representation**



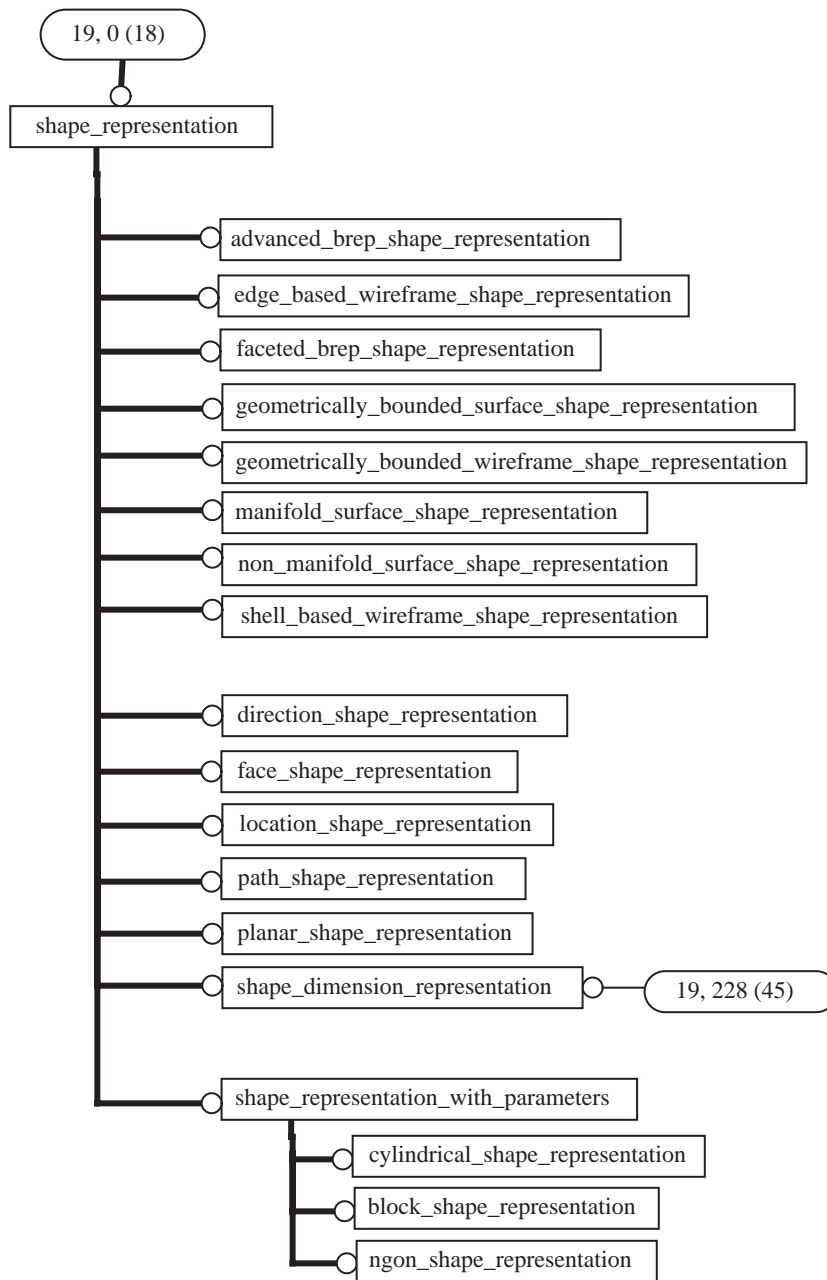
**Figure H.16 — AIM EXPRESS-G diagram externally defined item**



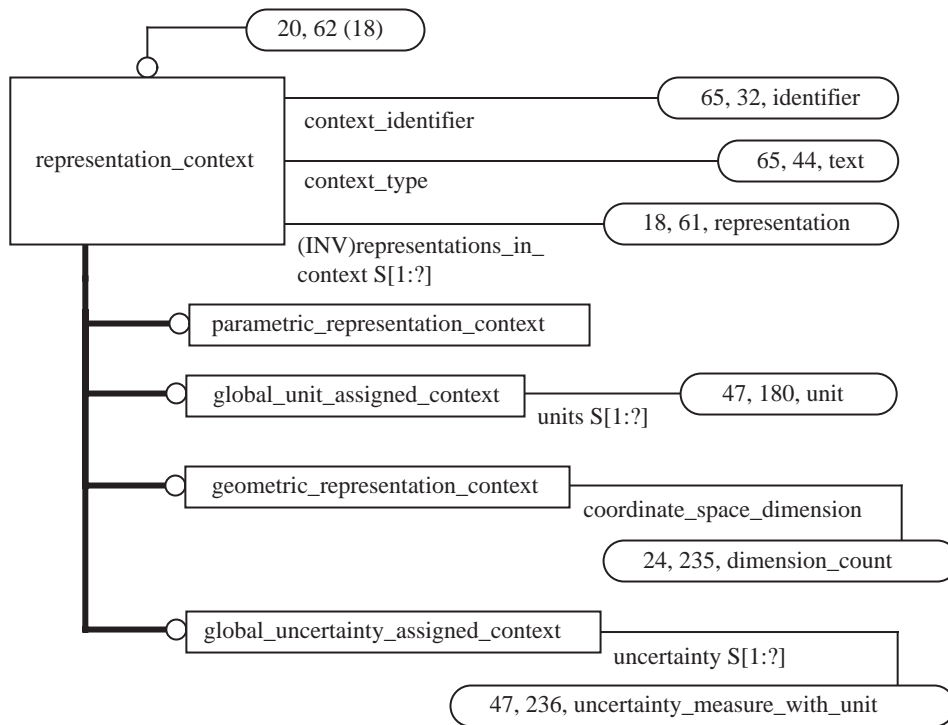
**Figure H.17 — AIM EXPRESS-G diagram identification assignment**



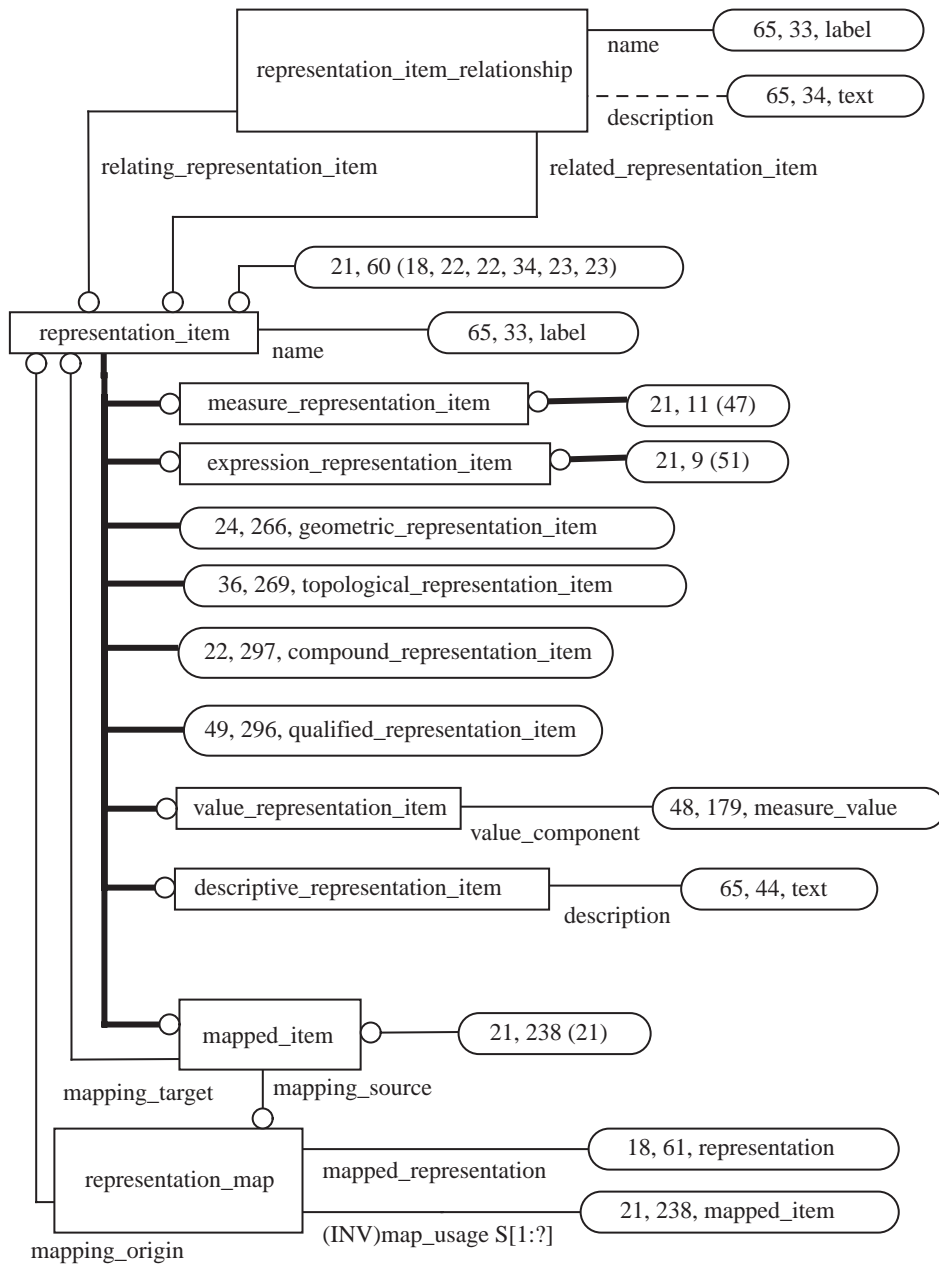
**Figure H.18 — AIM EXPRESS-G diagram representation**



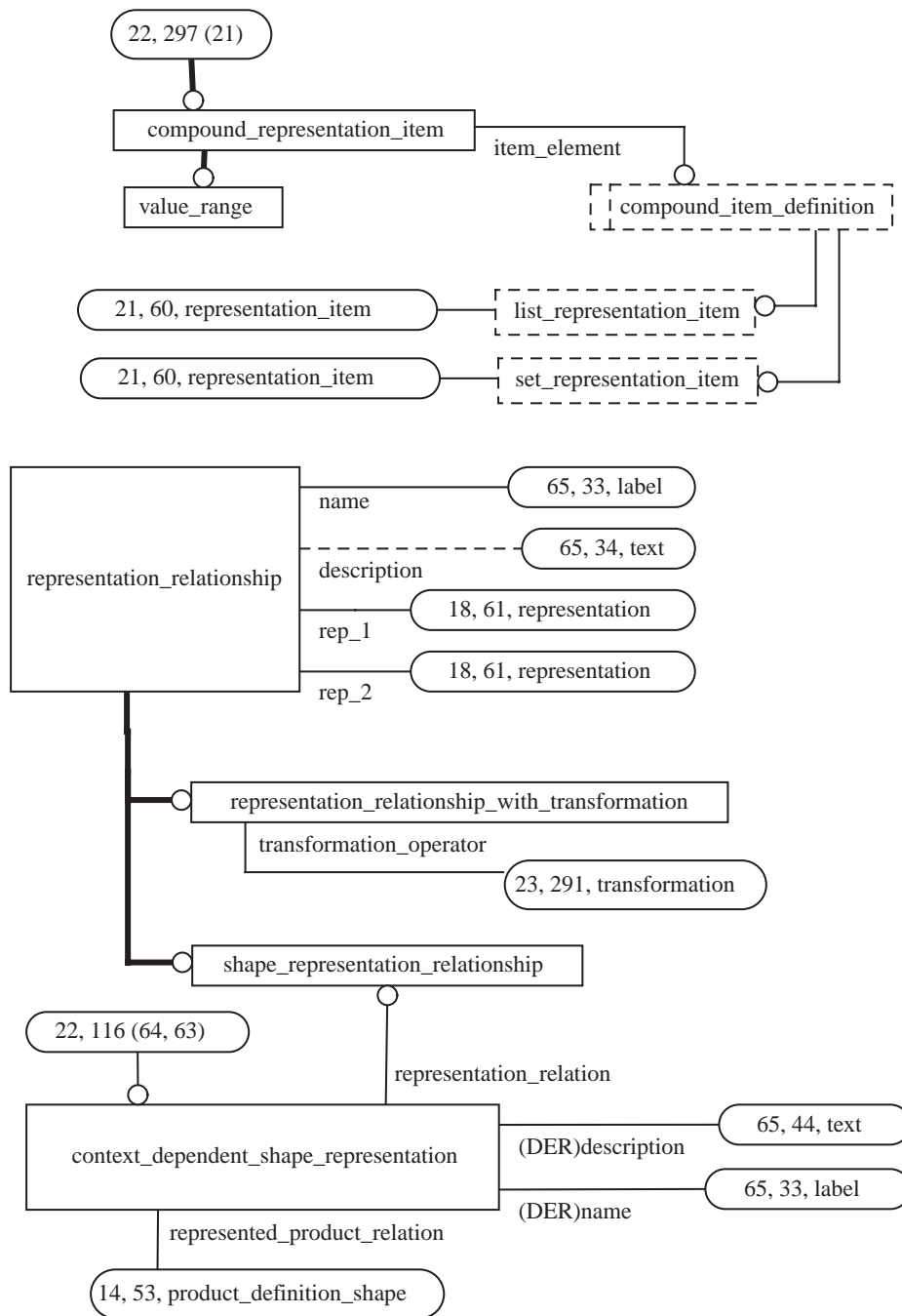
**Figure H.19 — AIM EXPRESS-G diagram shape representation**



**Figure H.20 — AIM EXPRESS-G diagram representation context**

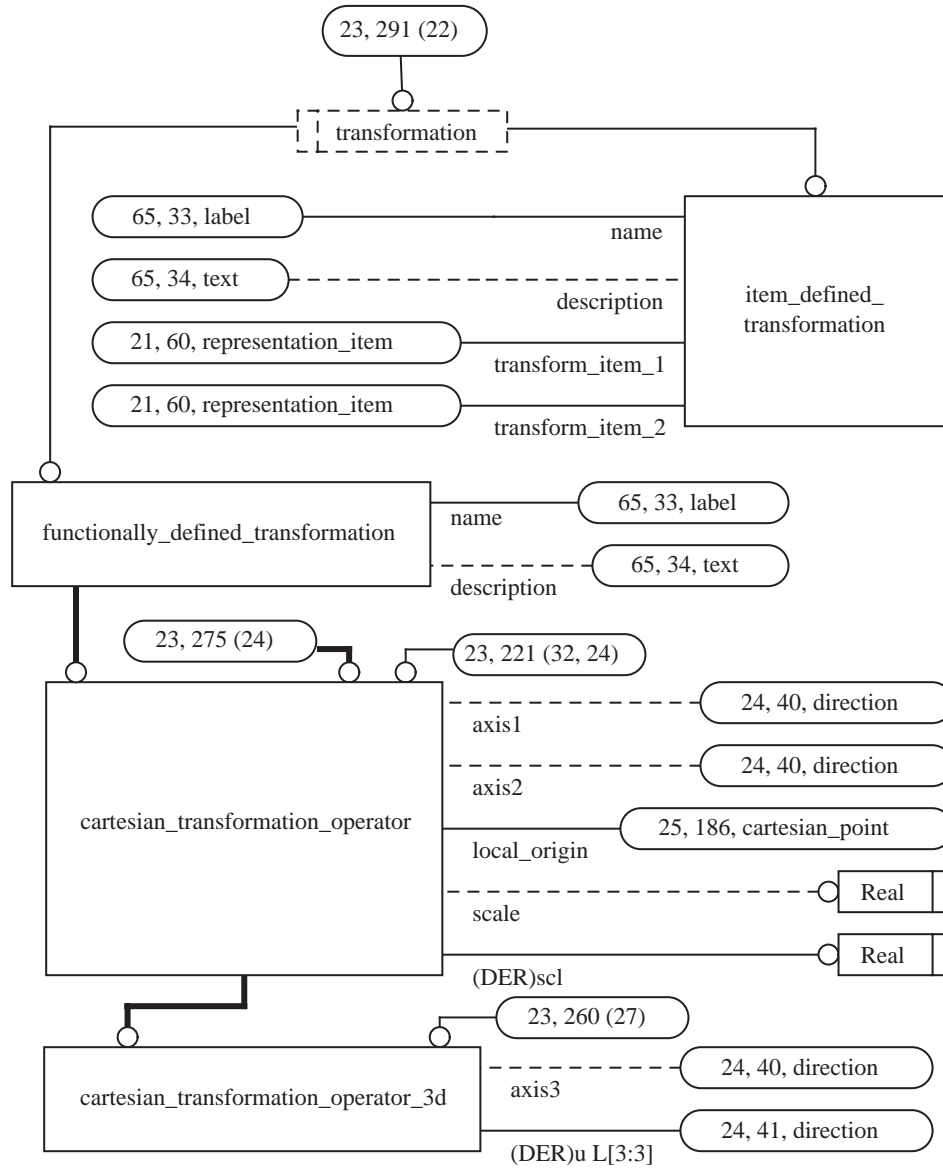


**Figure H.21 — AIM EXPRESS-G diagram representation item**



**Figure H.22 — AIM EXPRESS-G diagram representation relationship**





**Figure H.23 — AIM EXPRESS-G diagram transformation**

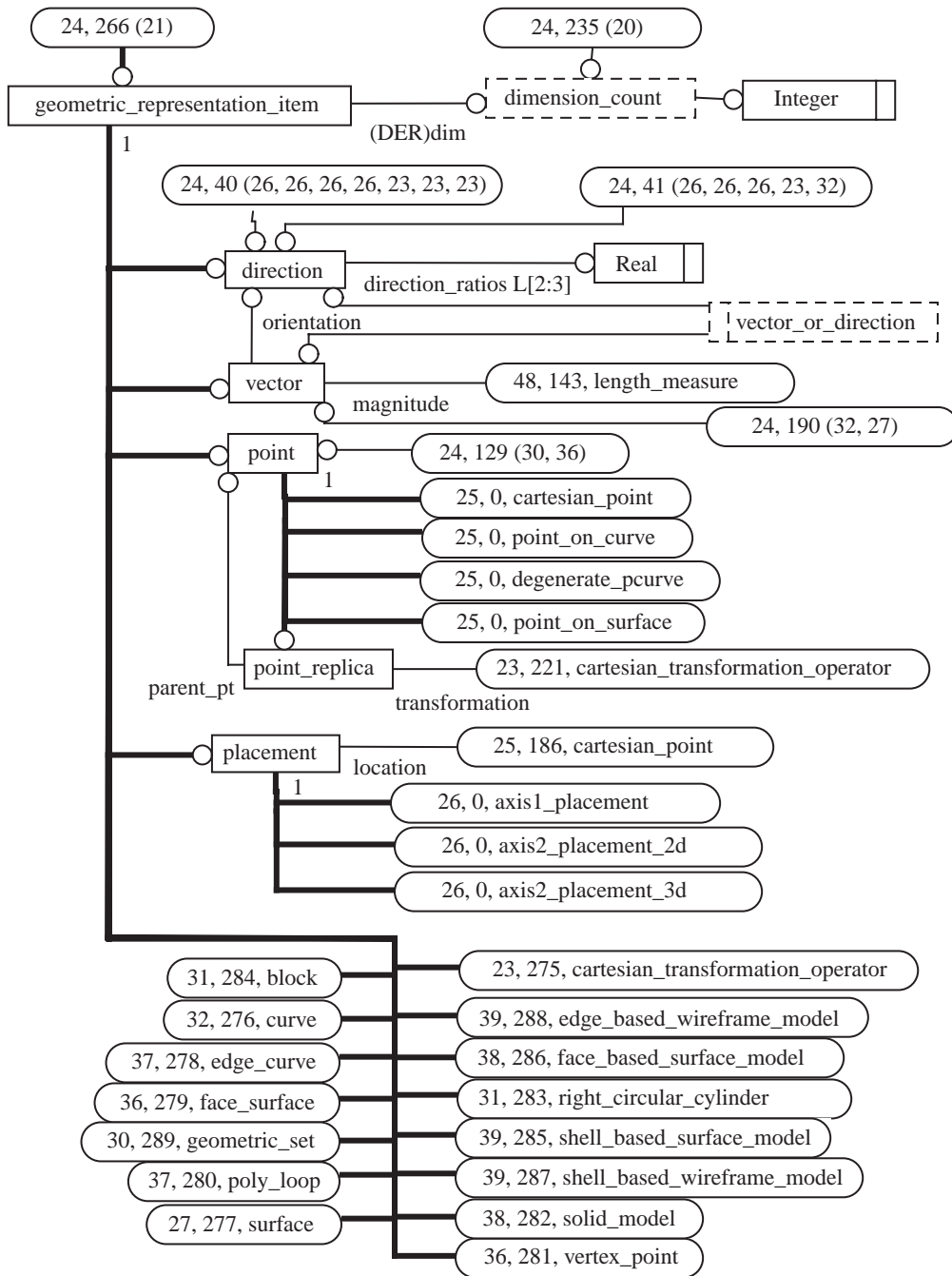
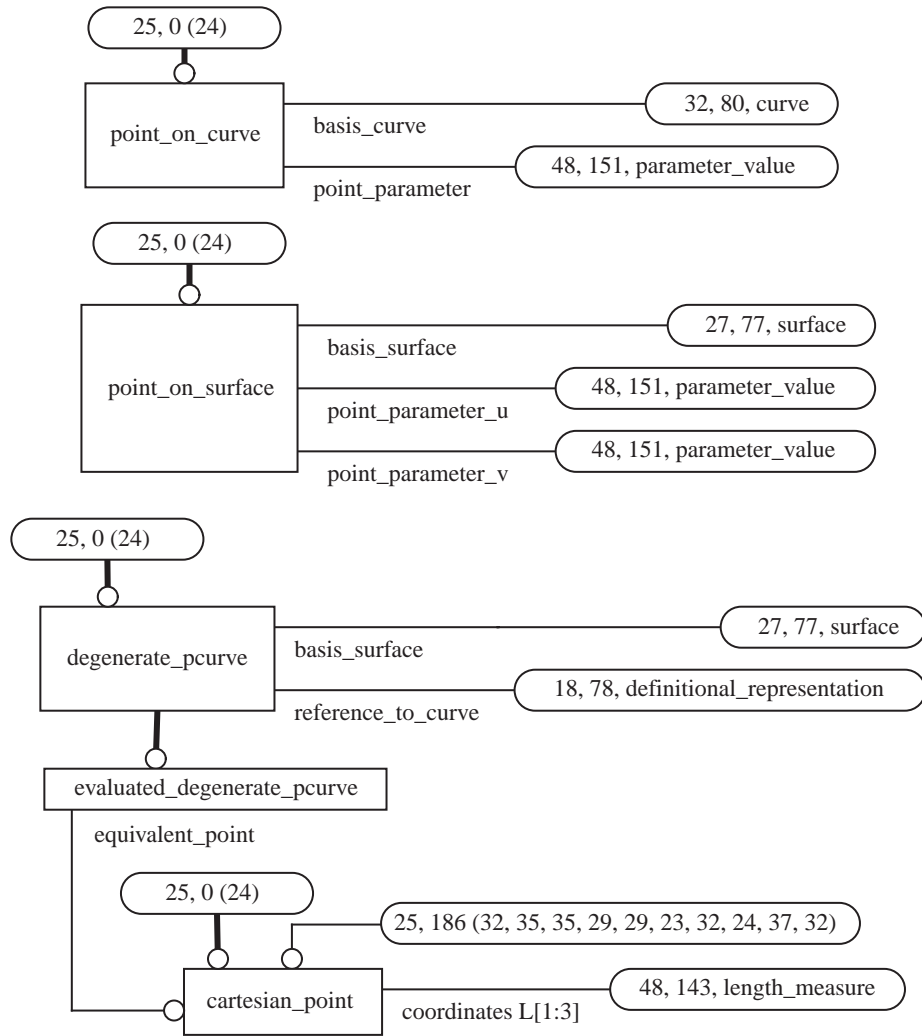
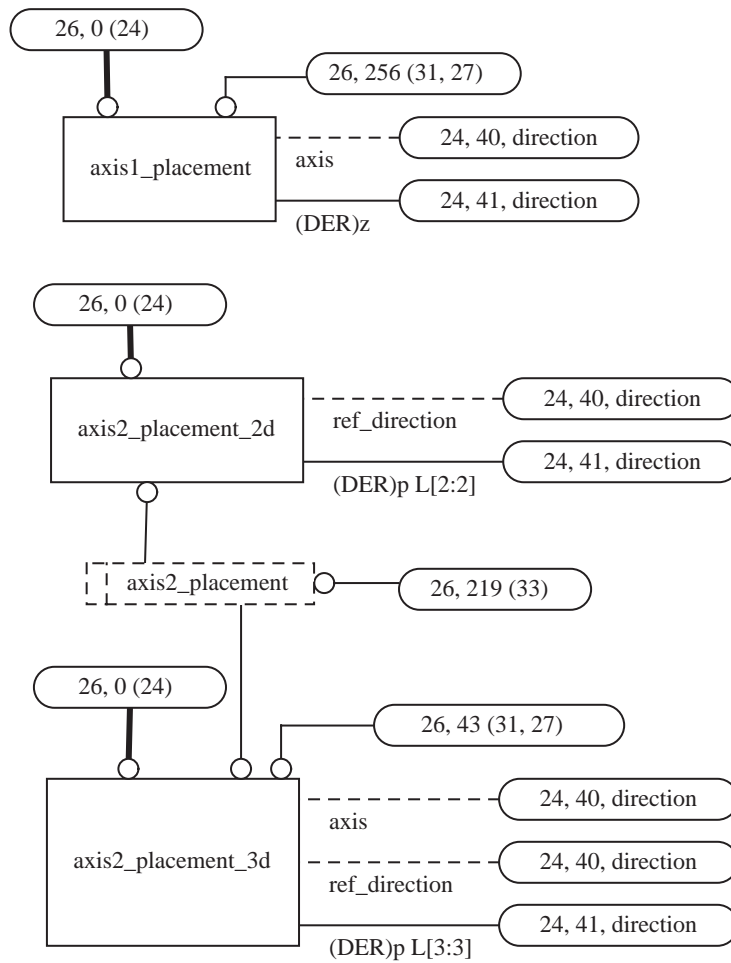


Figure H.24 — AIM EXPRESS-G diagram geometric representation item



**Figure H.25 — AIM EXPRESS-G diagram points**



**Figure H.26 — AIM EXPRESS-G diagram placement**

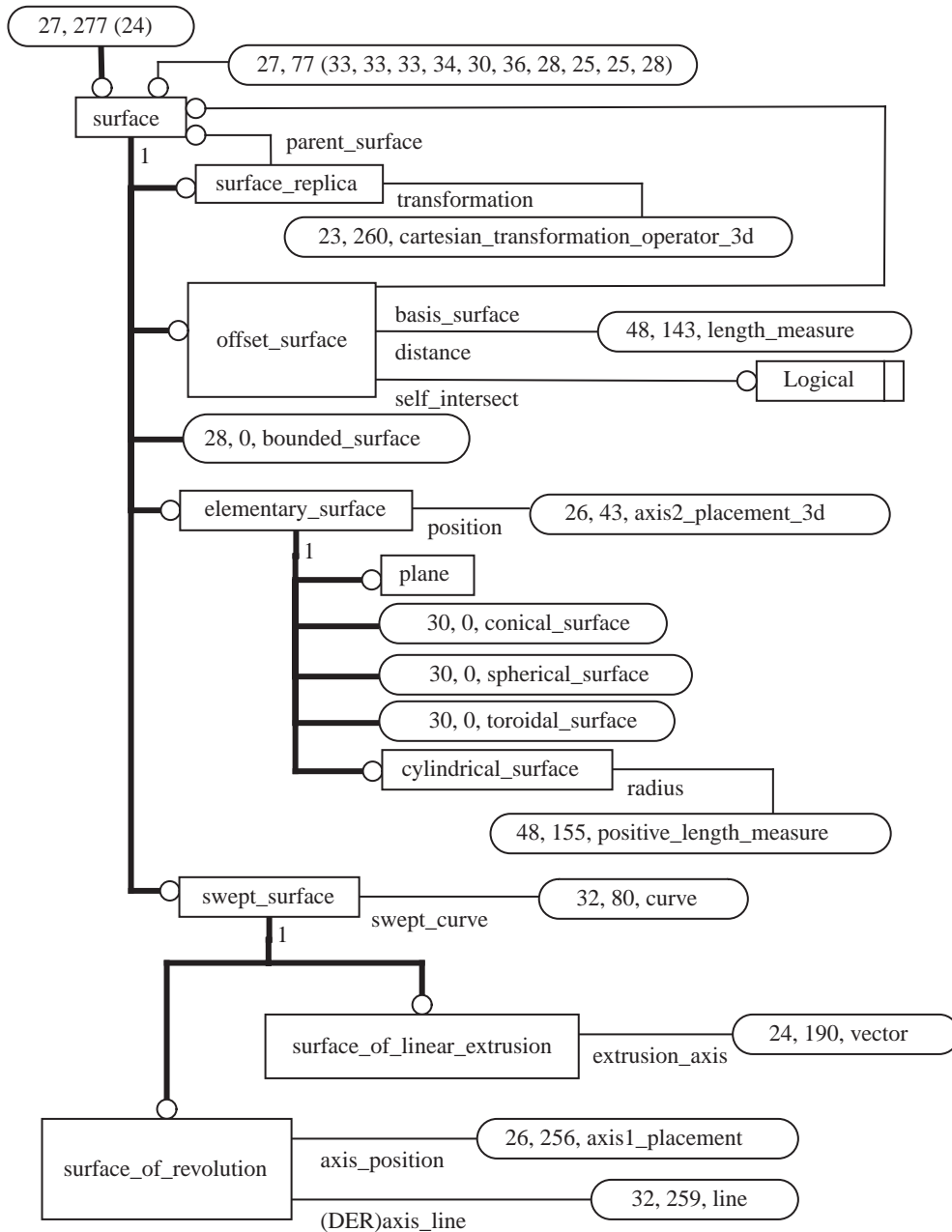


Figure H.27 — AIM EXPRESS-G diagram surface

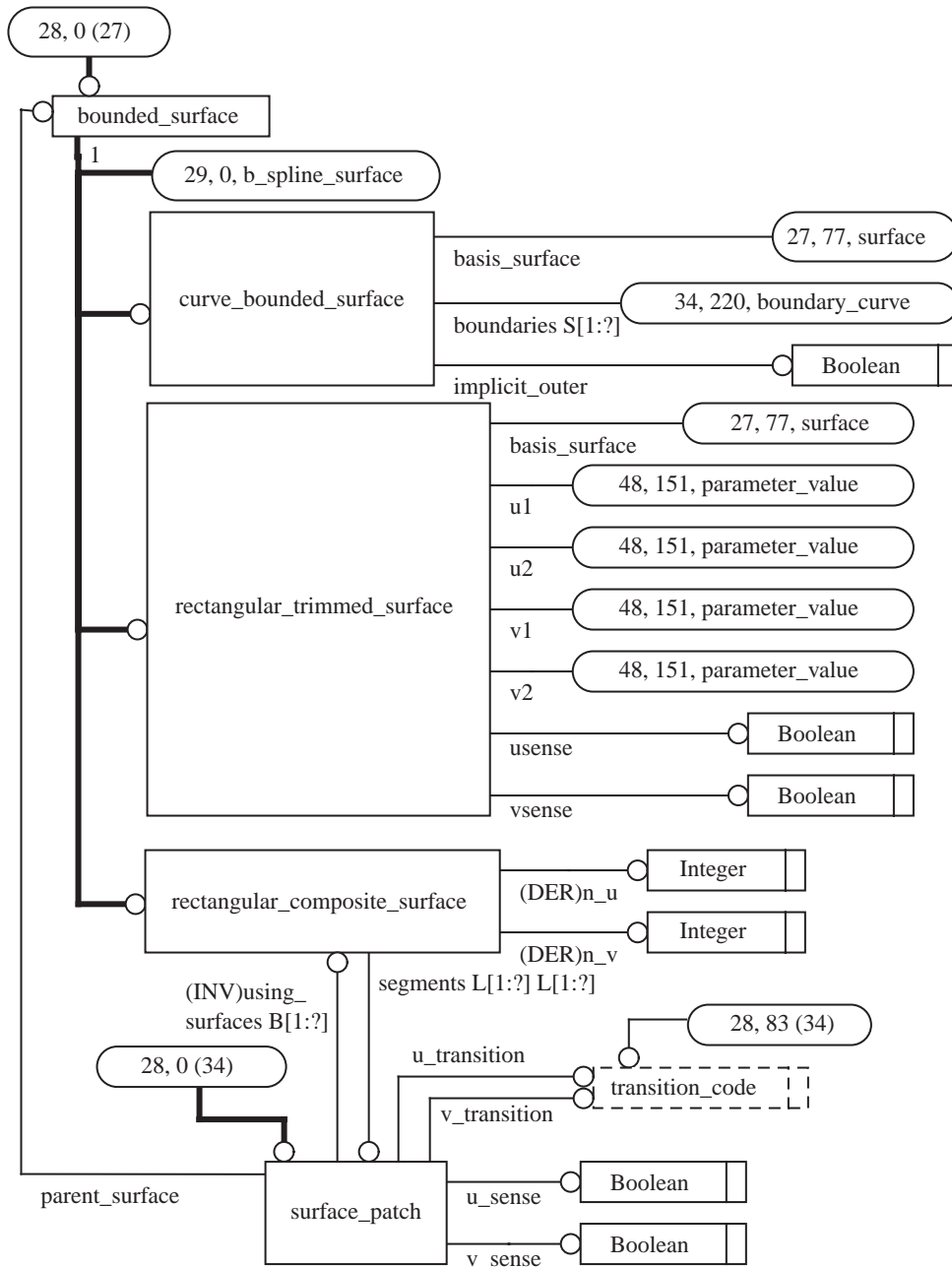
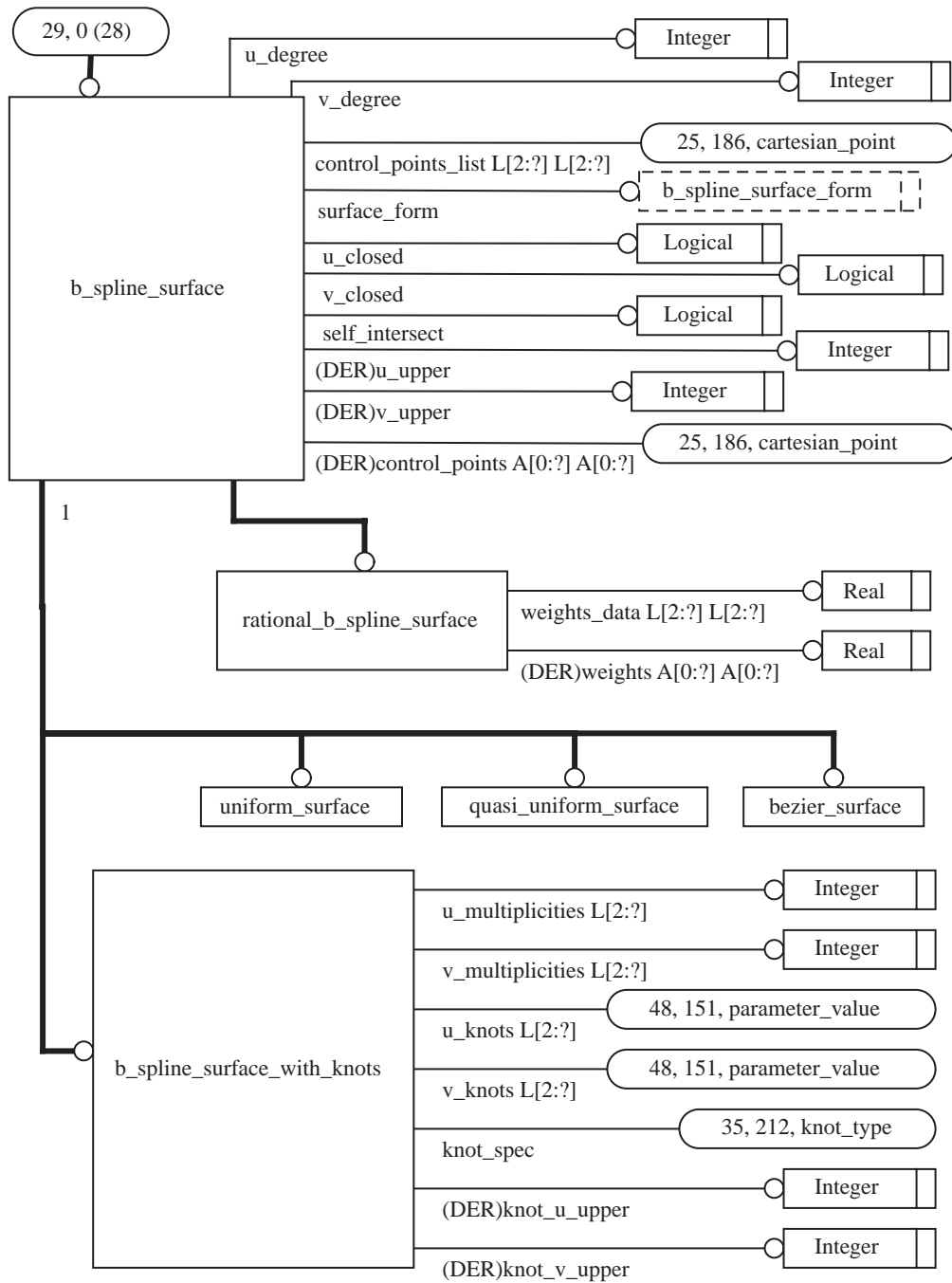
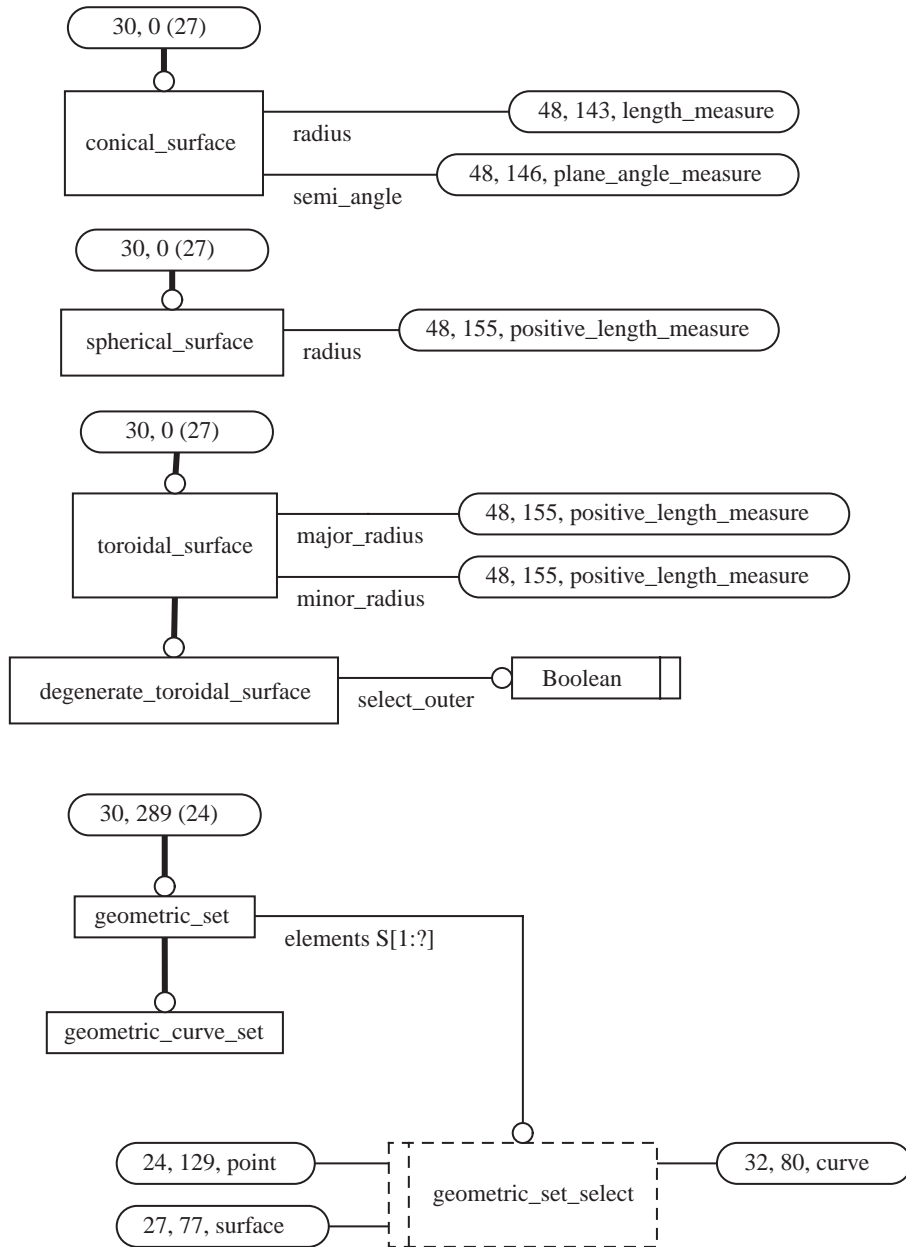


Figure H.28 — AIM EXPRESS-G diagram bounded surface

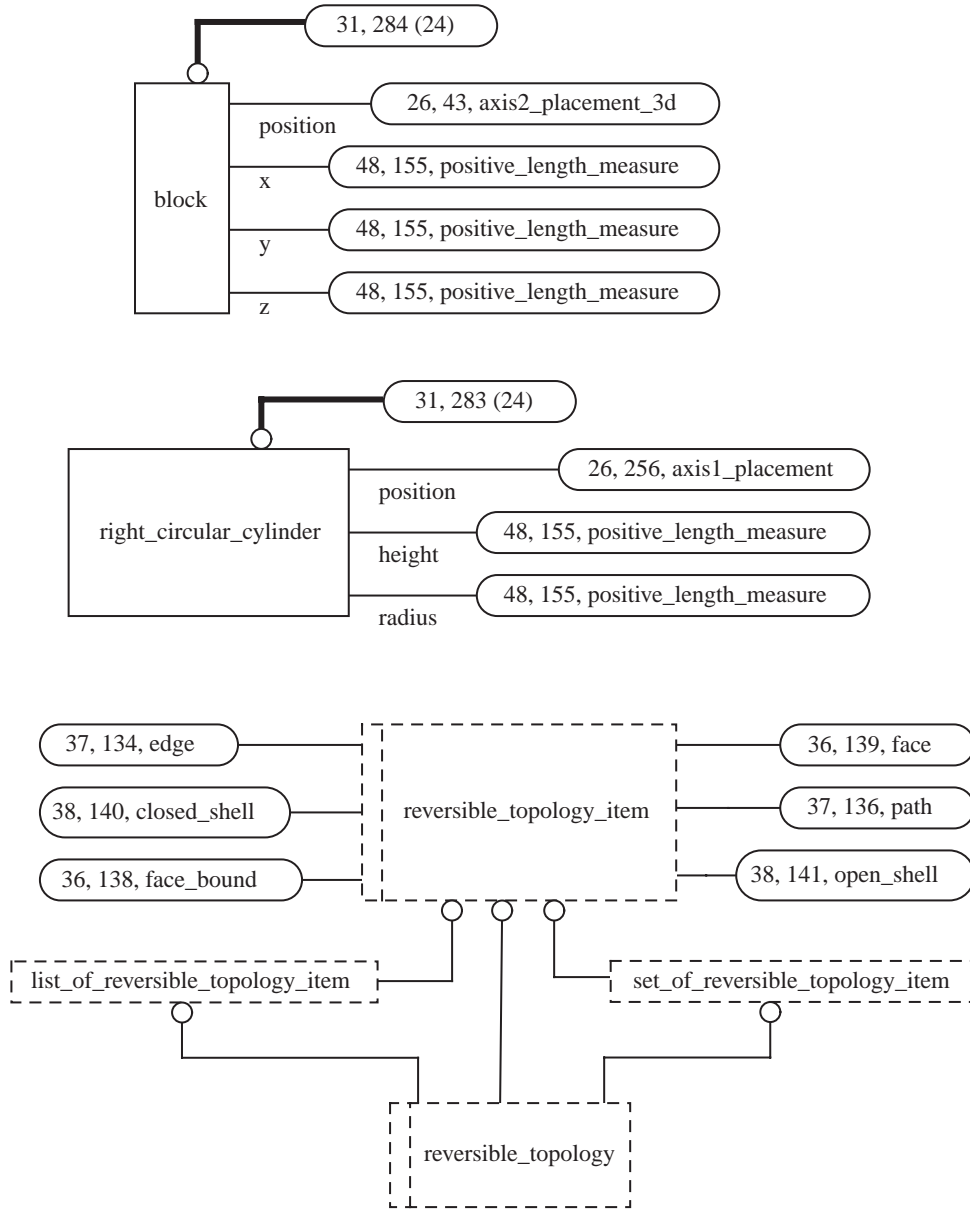


**Figure H.29 — AIM EXPRESS-G diagram b-spline surface**



**Figure H.30 — AIM EXPRESS-G diagram other surface**





**Figure H.31 — AIM EXPRESS-G diagram block and cylinder**

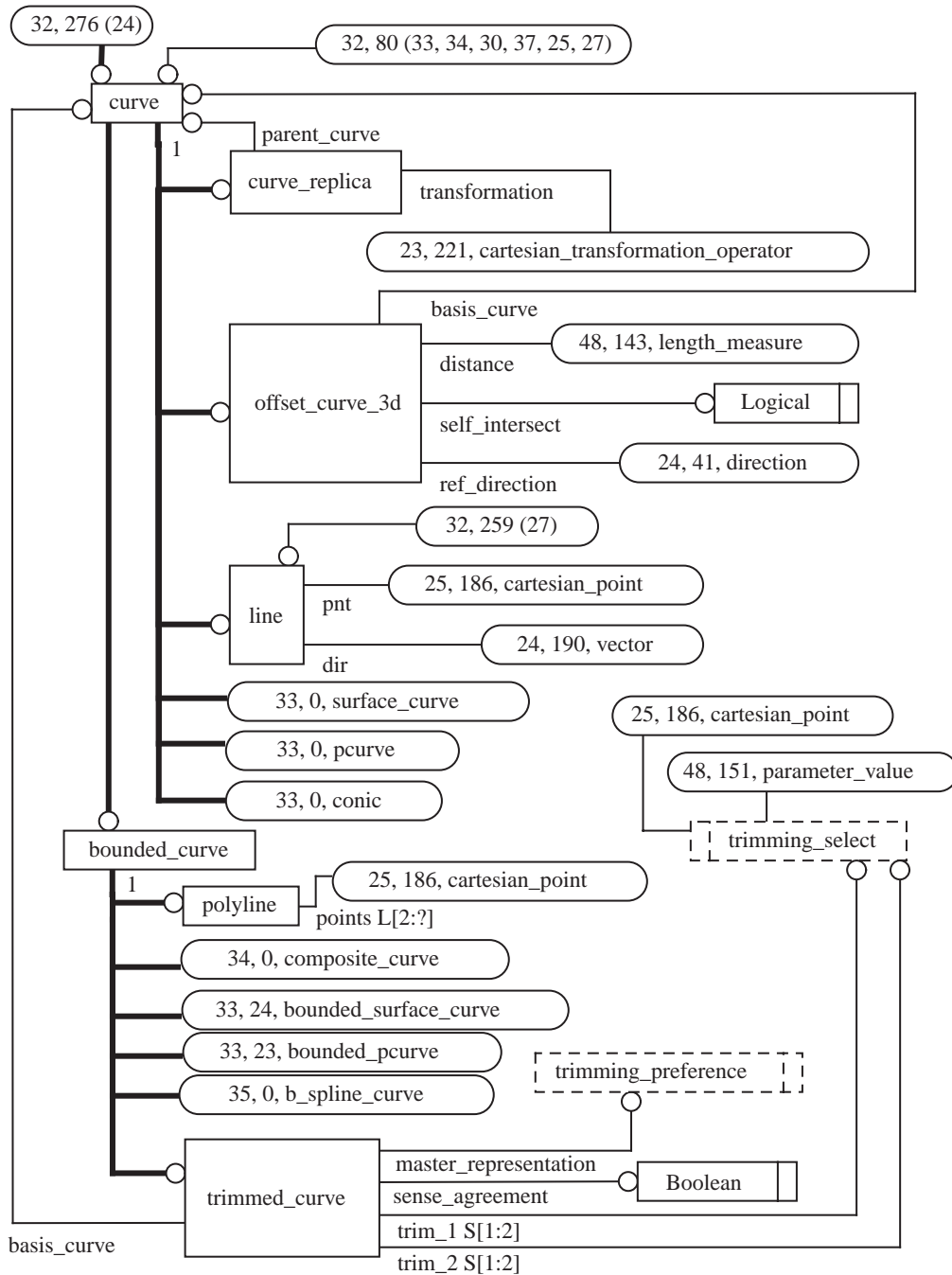
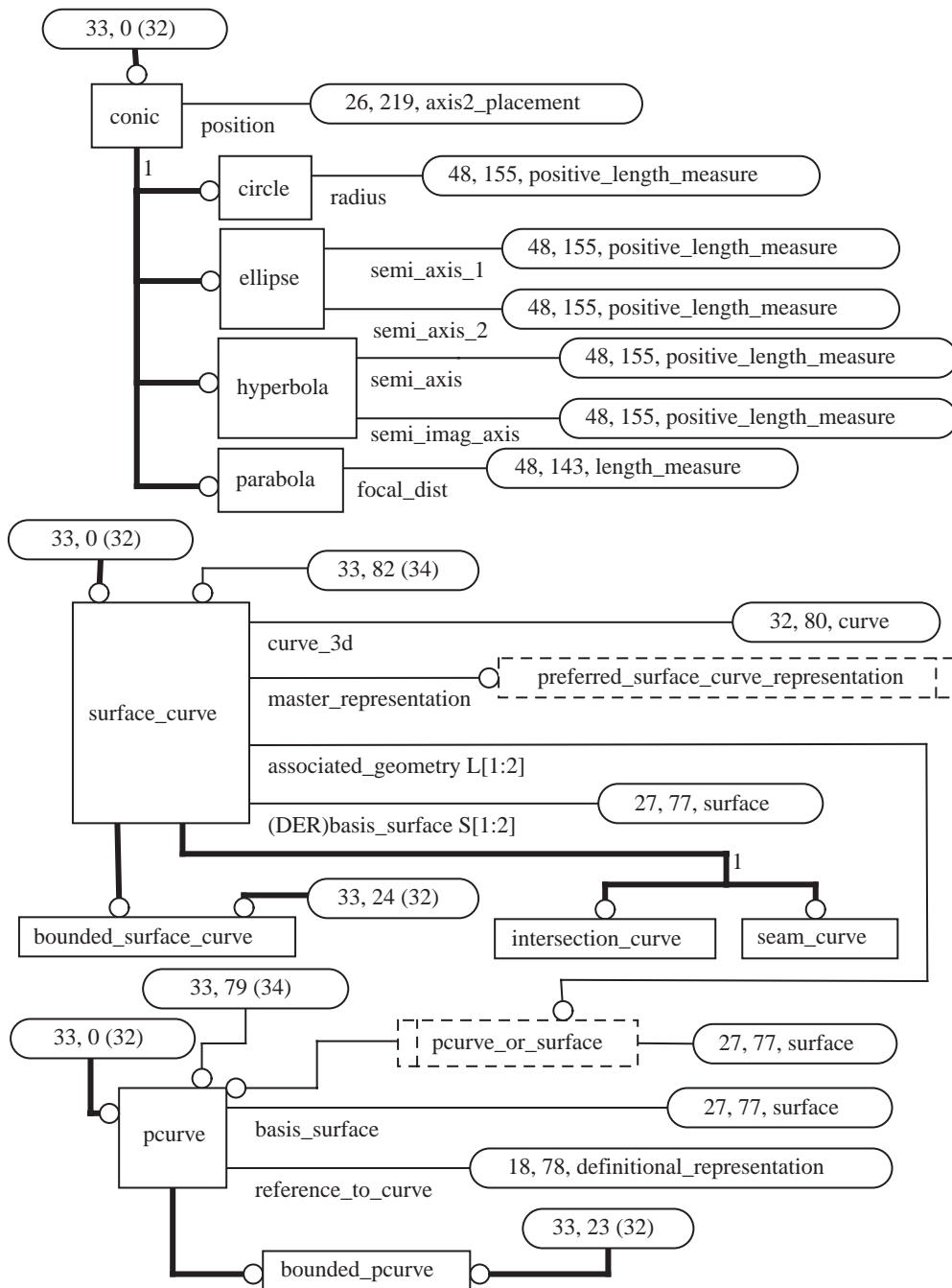


Figure H.32 — AIM EXPRESS-G diagram curve



**Figure H.33 — AIM EXPRESS-G diagram conic**

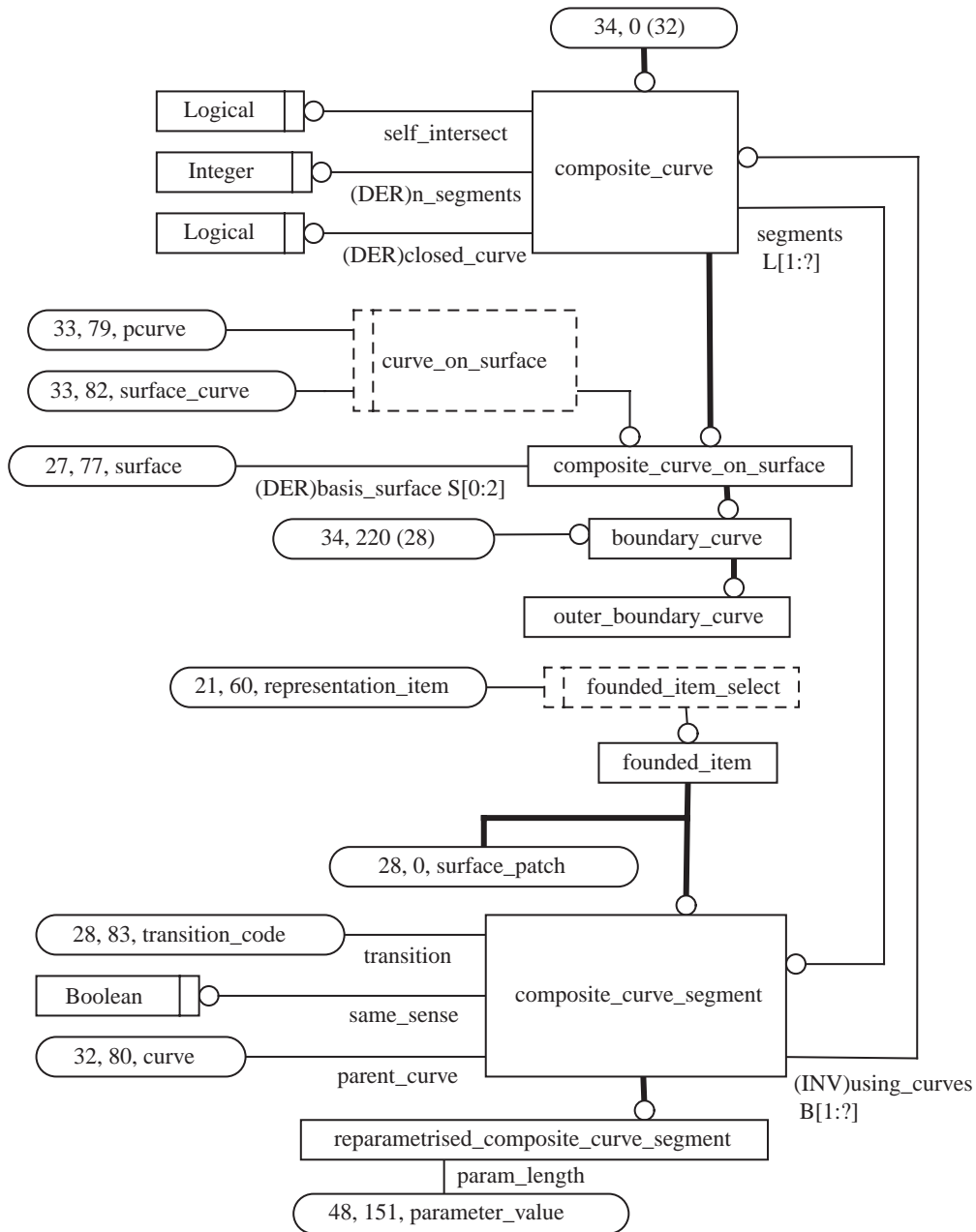
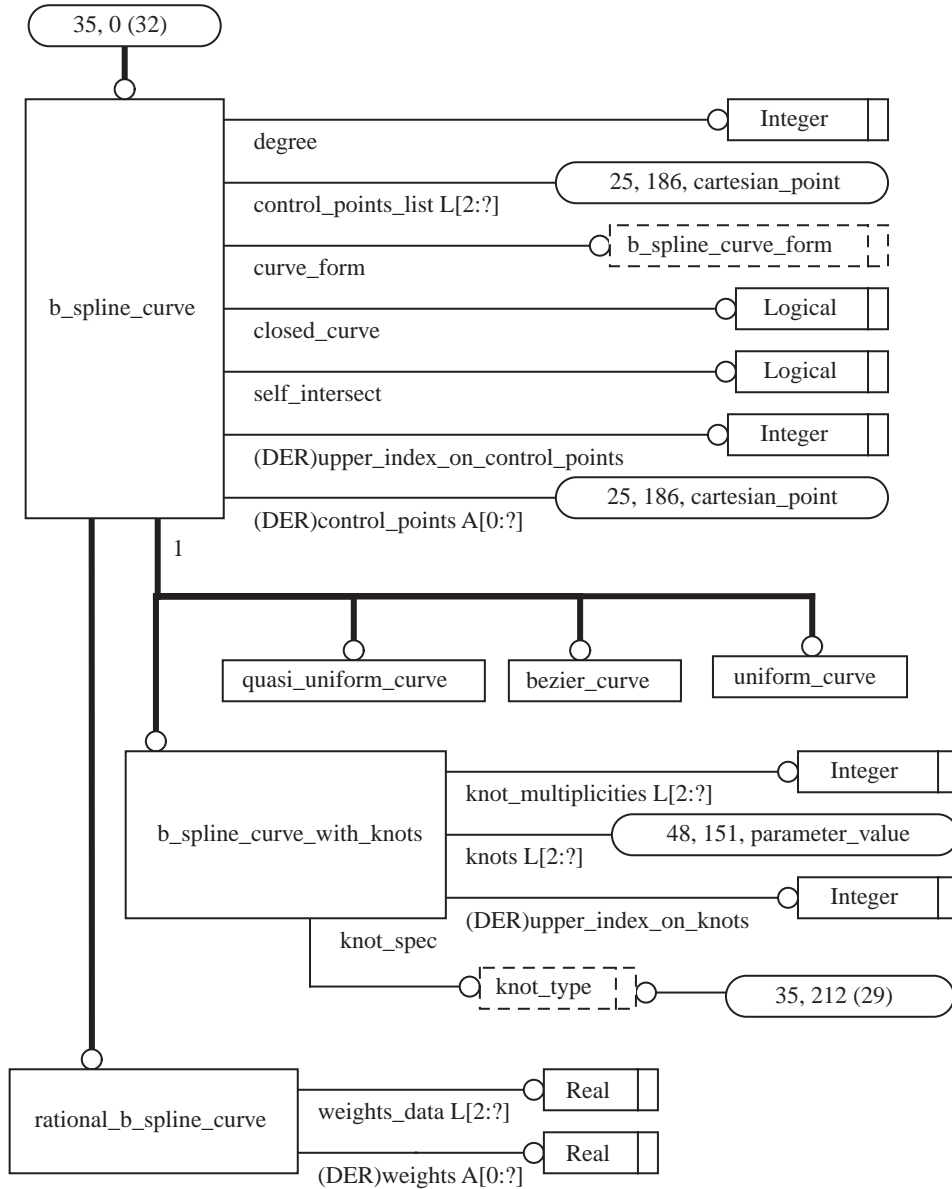
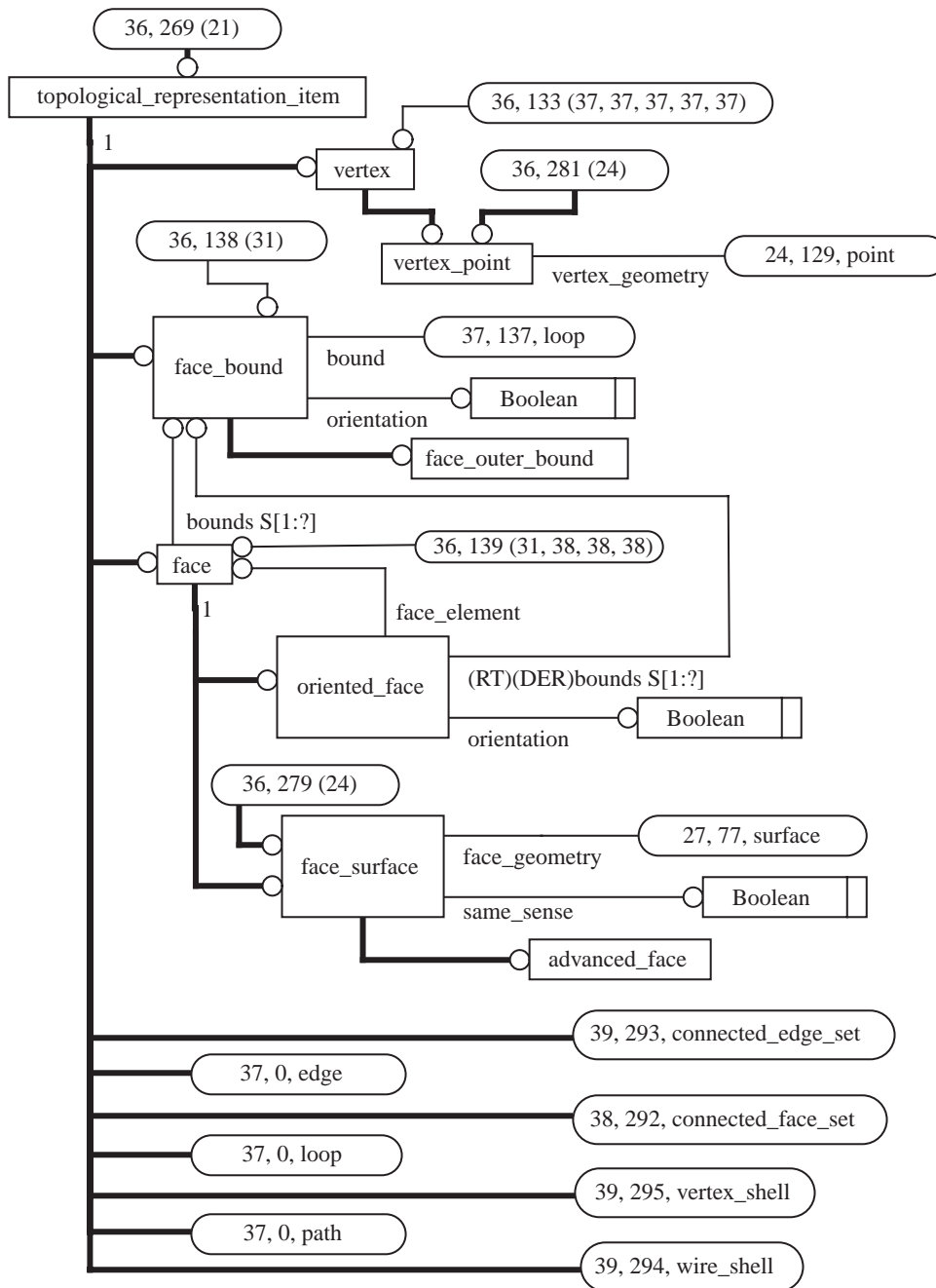


Figure H.34 — AIM EXPRESS-G diagram composite curve



**Figure H.35 — AIM EXPRESS-G diagram b-spline curve**



**Figure H.36 — AIM EXPRESS-G diagram topological representation item**

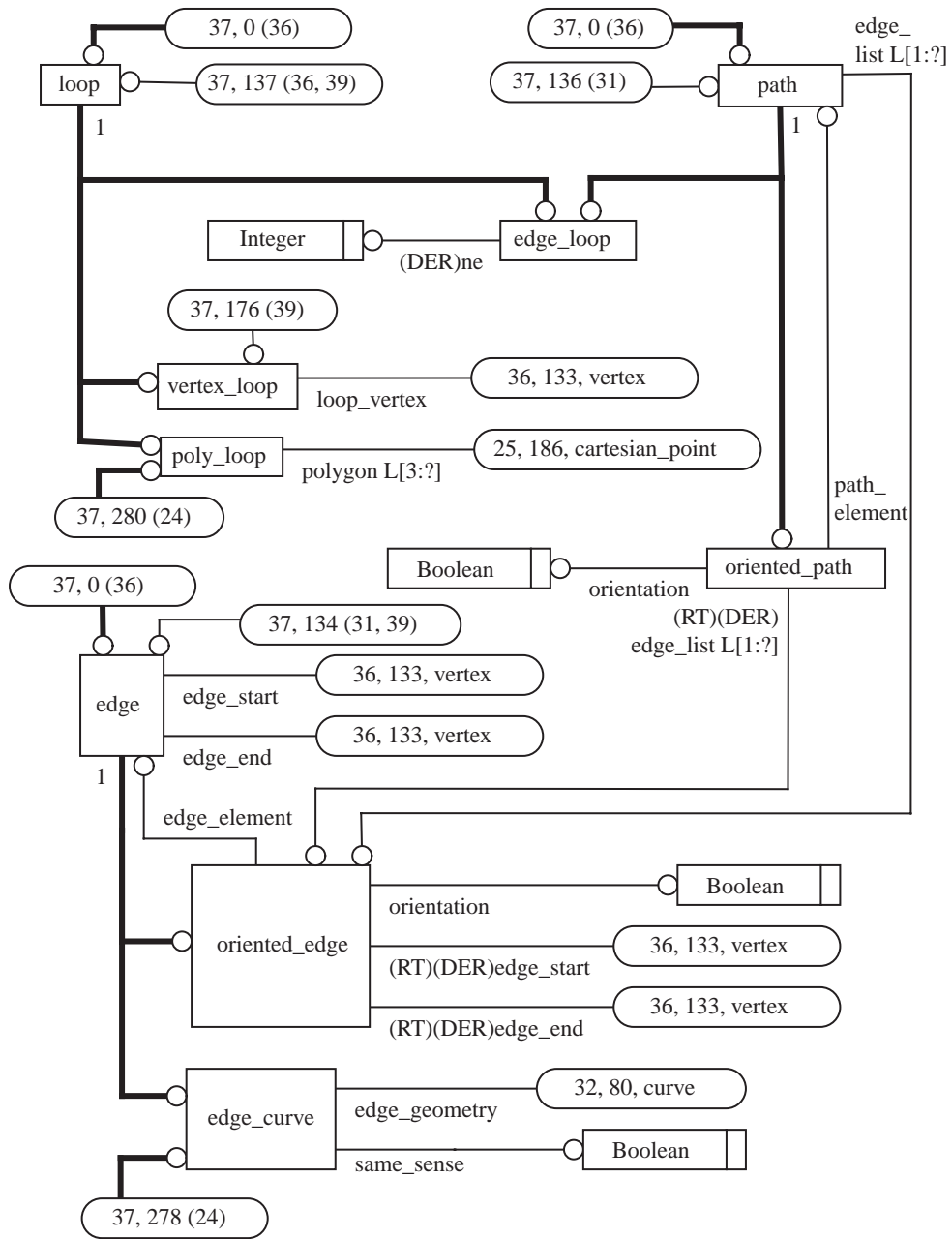


Figure H.37 — AIM EXPRESS-G diagram edge, loop, and path

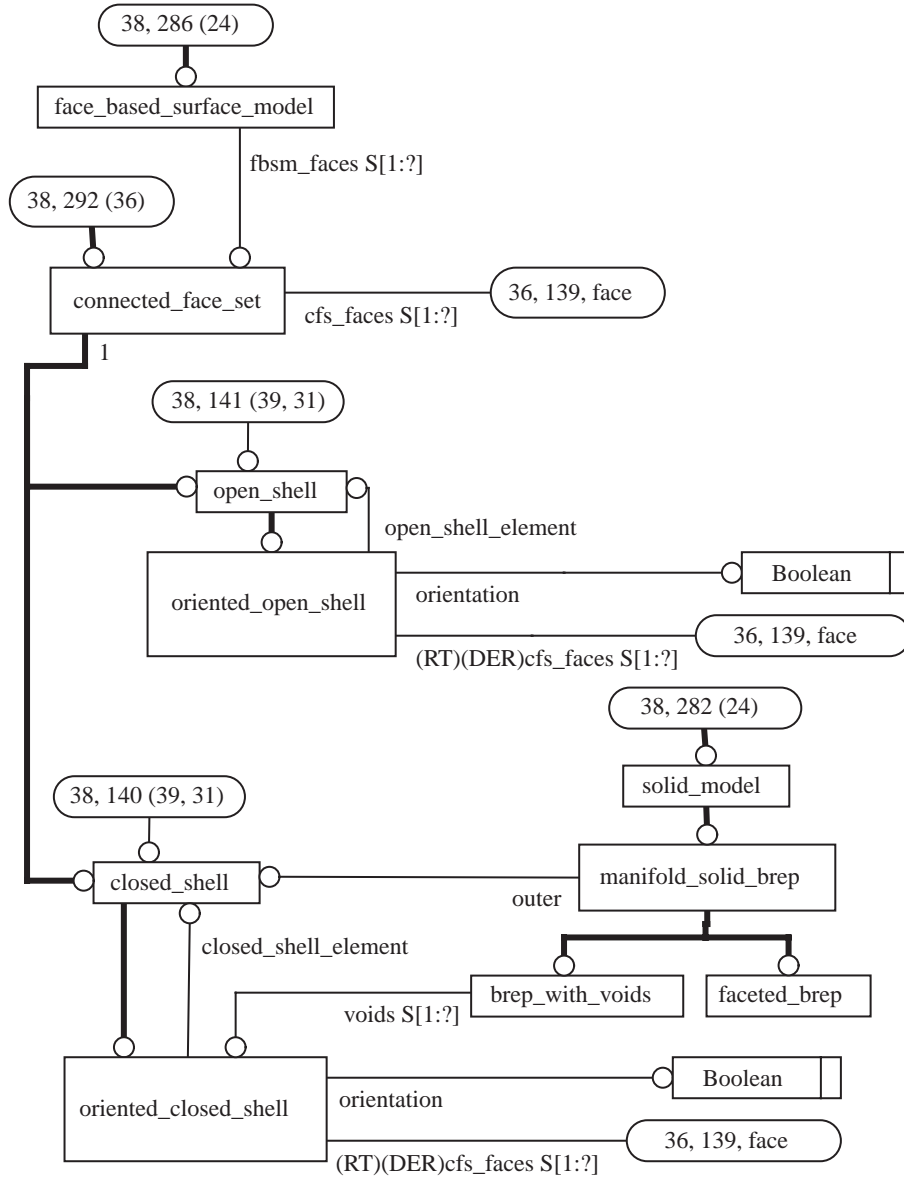
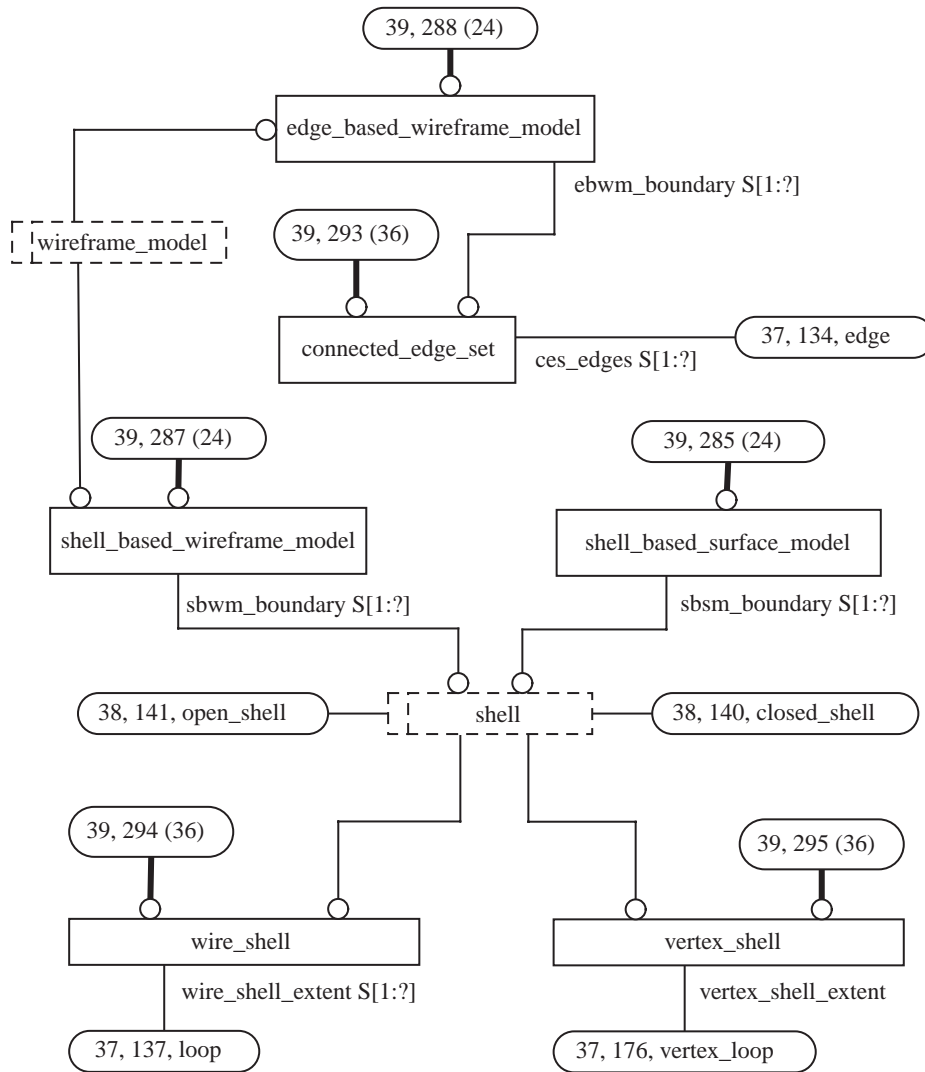
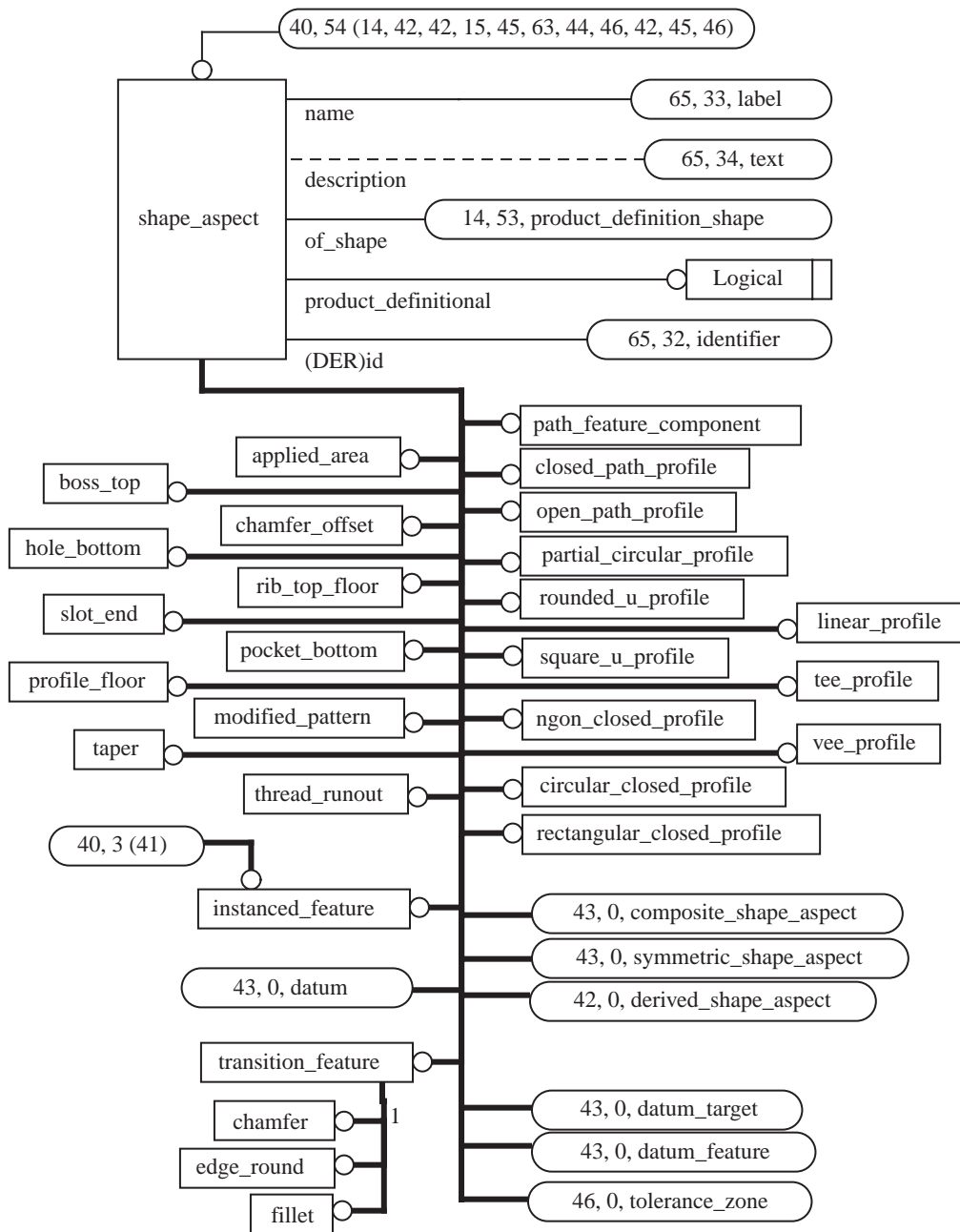


Figure H.38 — AIM EXPRESS-G diagram connected face set





**Figure H.39 — AIM EXPRESS-G diagram shell**



**Figure H.40 — AIM EXPRESS-G diagram shape aspect**

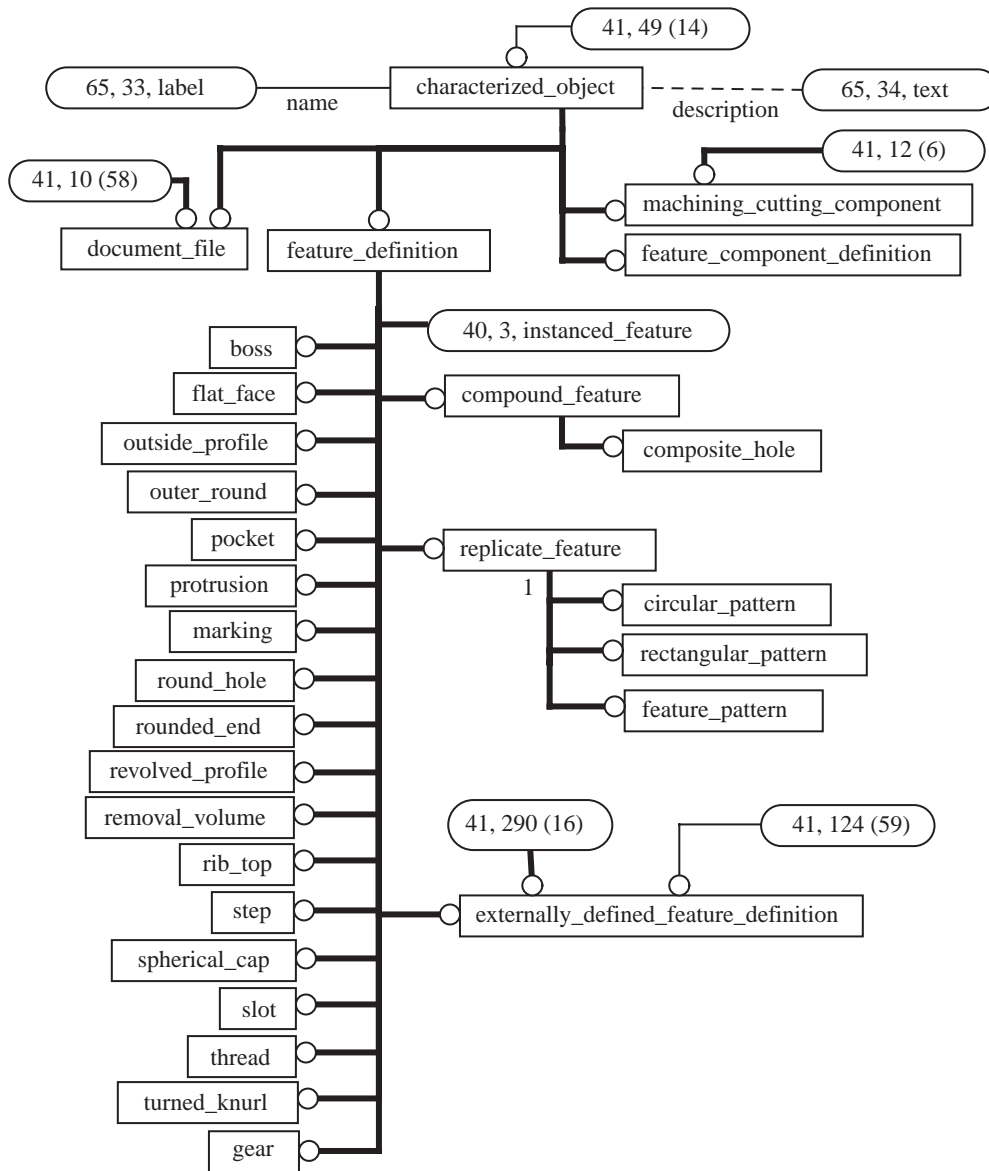


Figure H.41 — AIM EXPRESS-G diagram characterized object

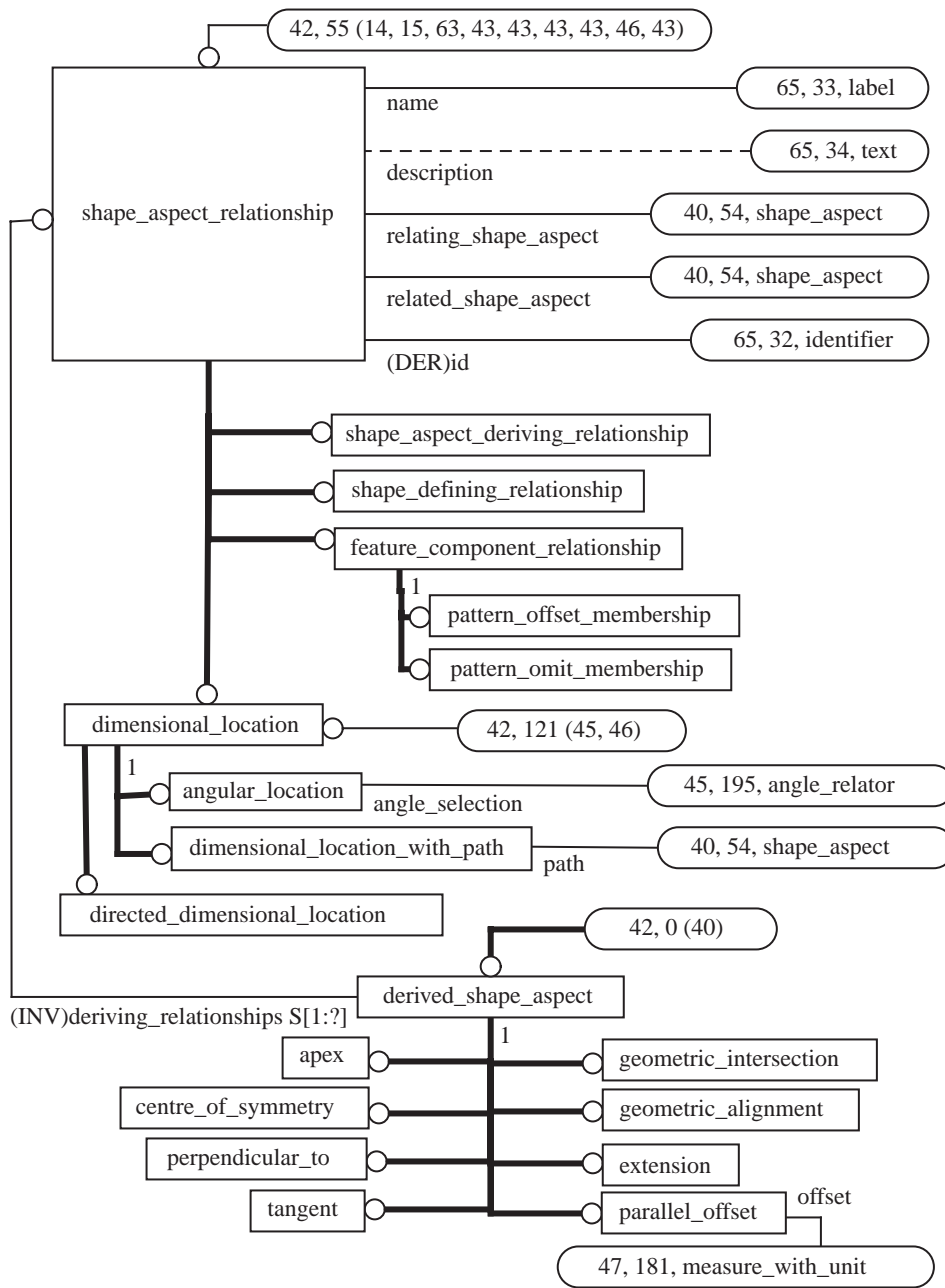
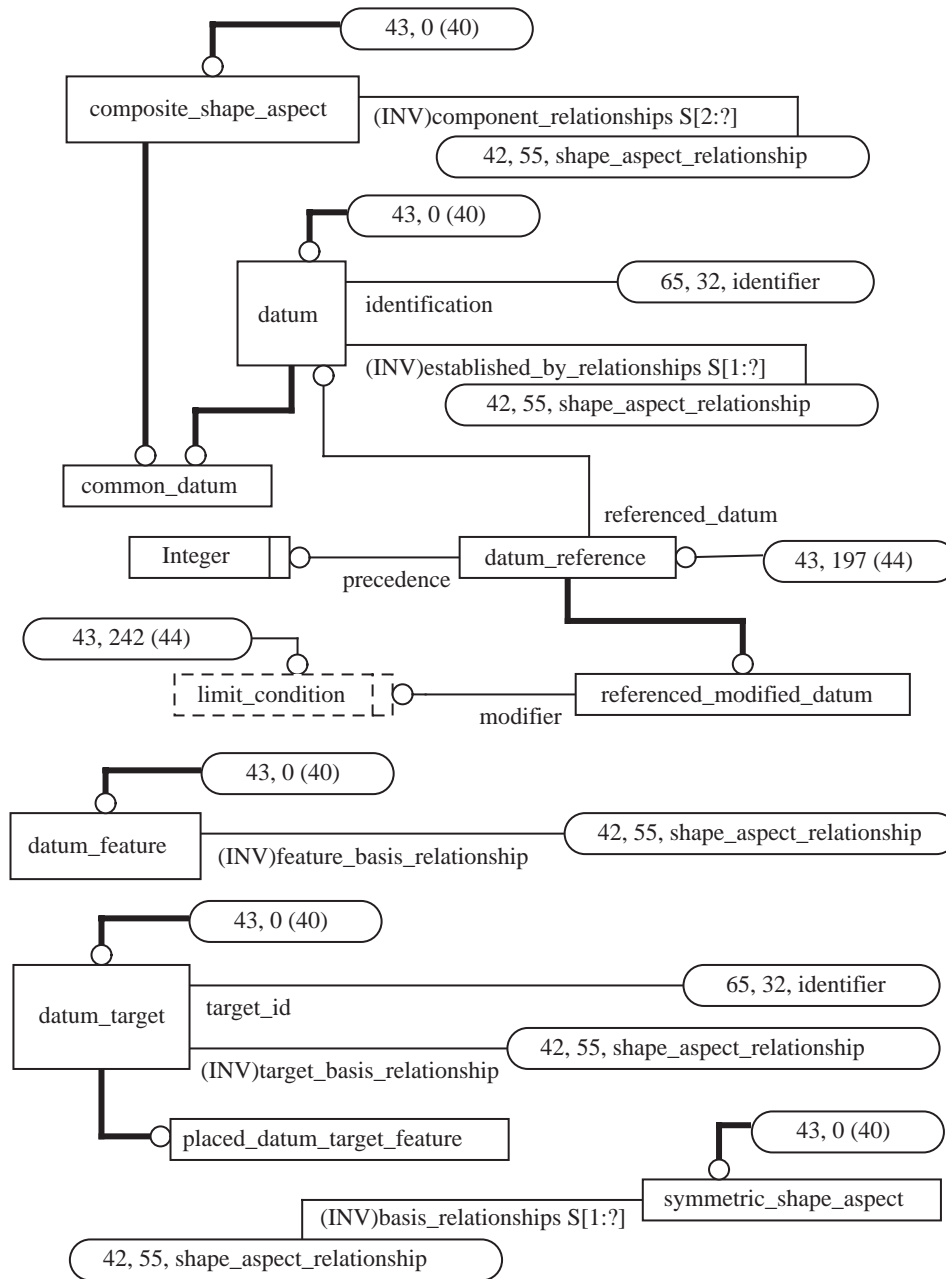


Figure H.42 — AIM EXPRESS-G diagram shape aspect relationship



**Figure H.43 — AIM EXPRESS-G diagram datum**

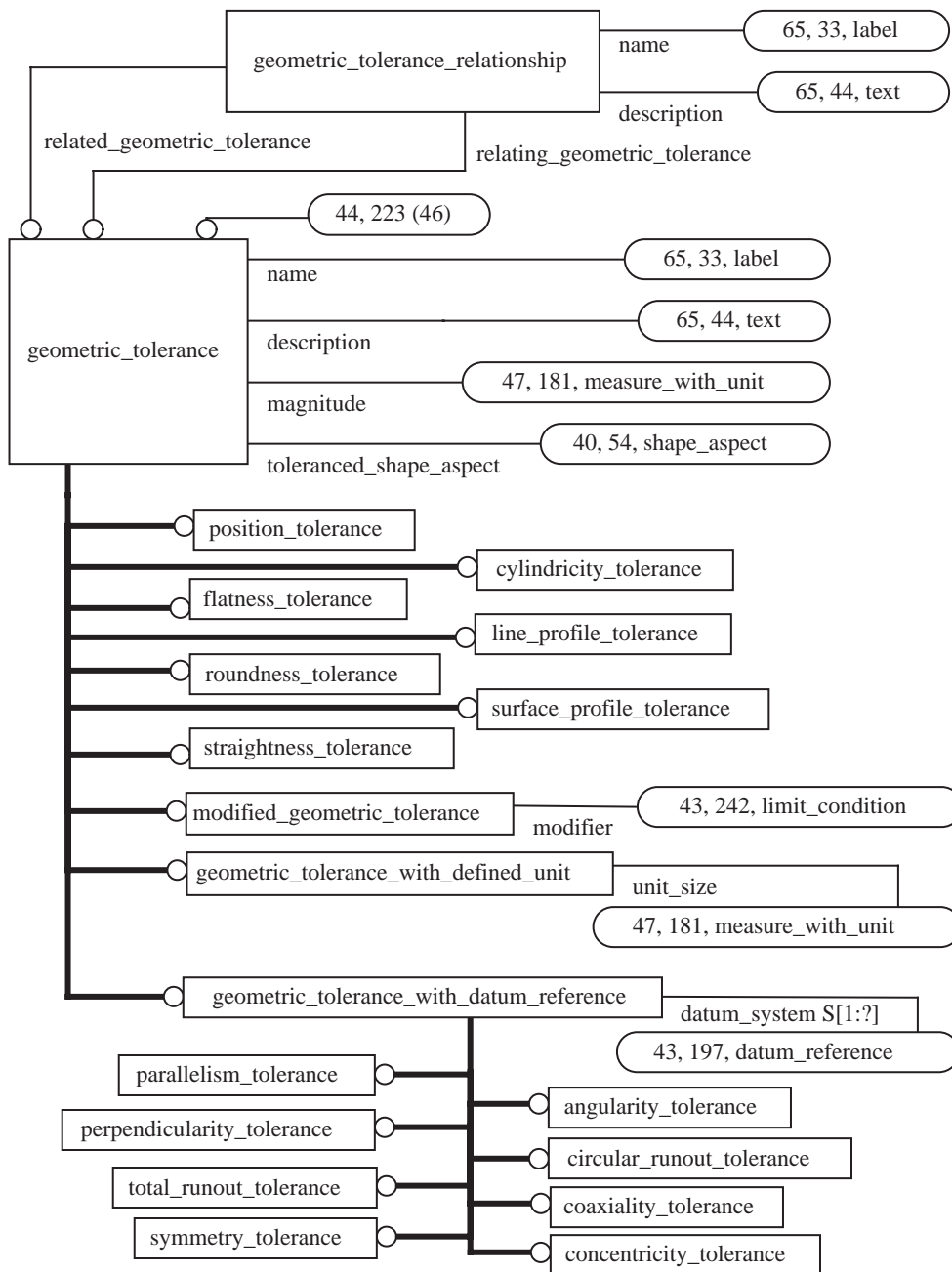
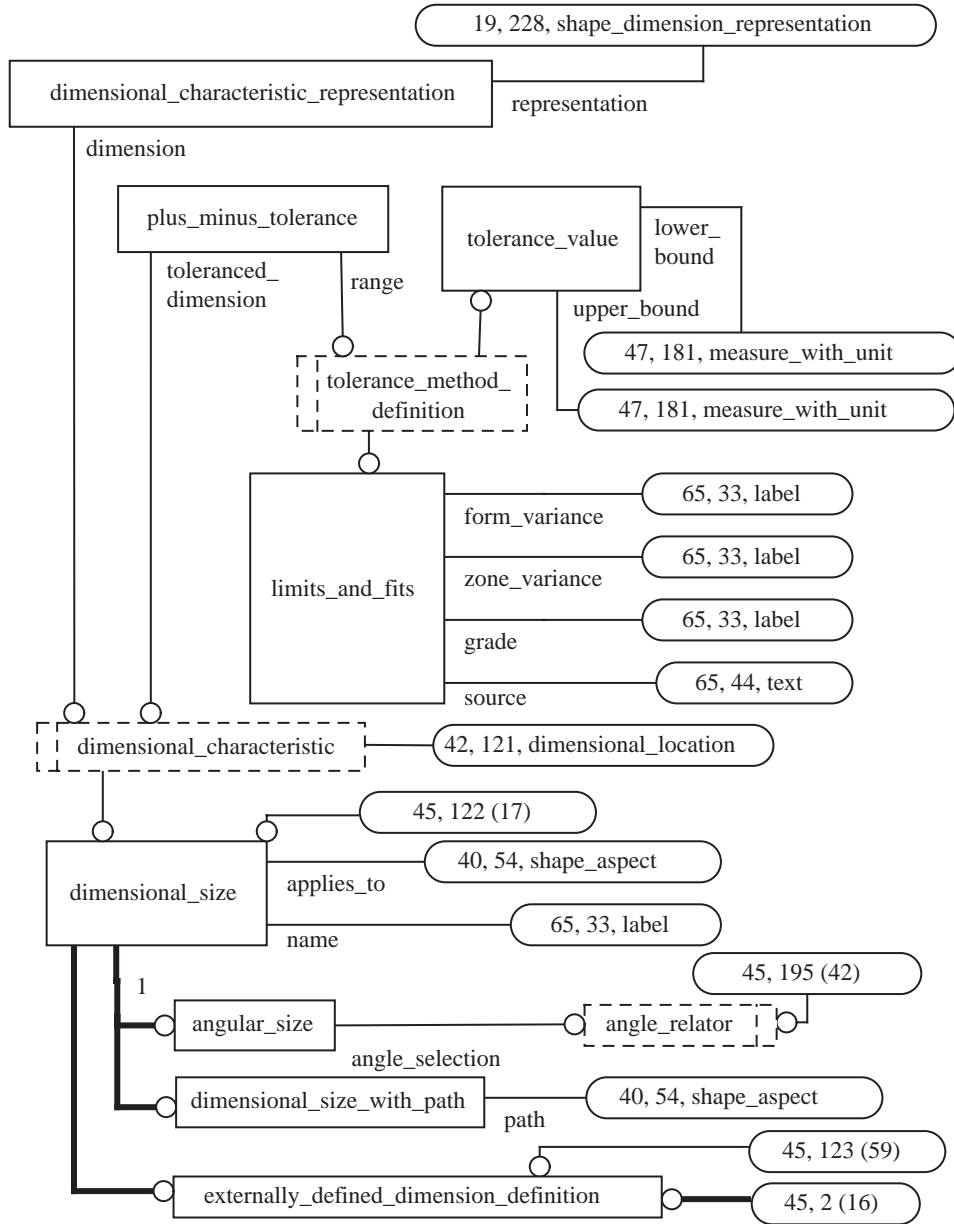
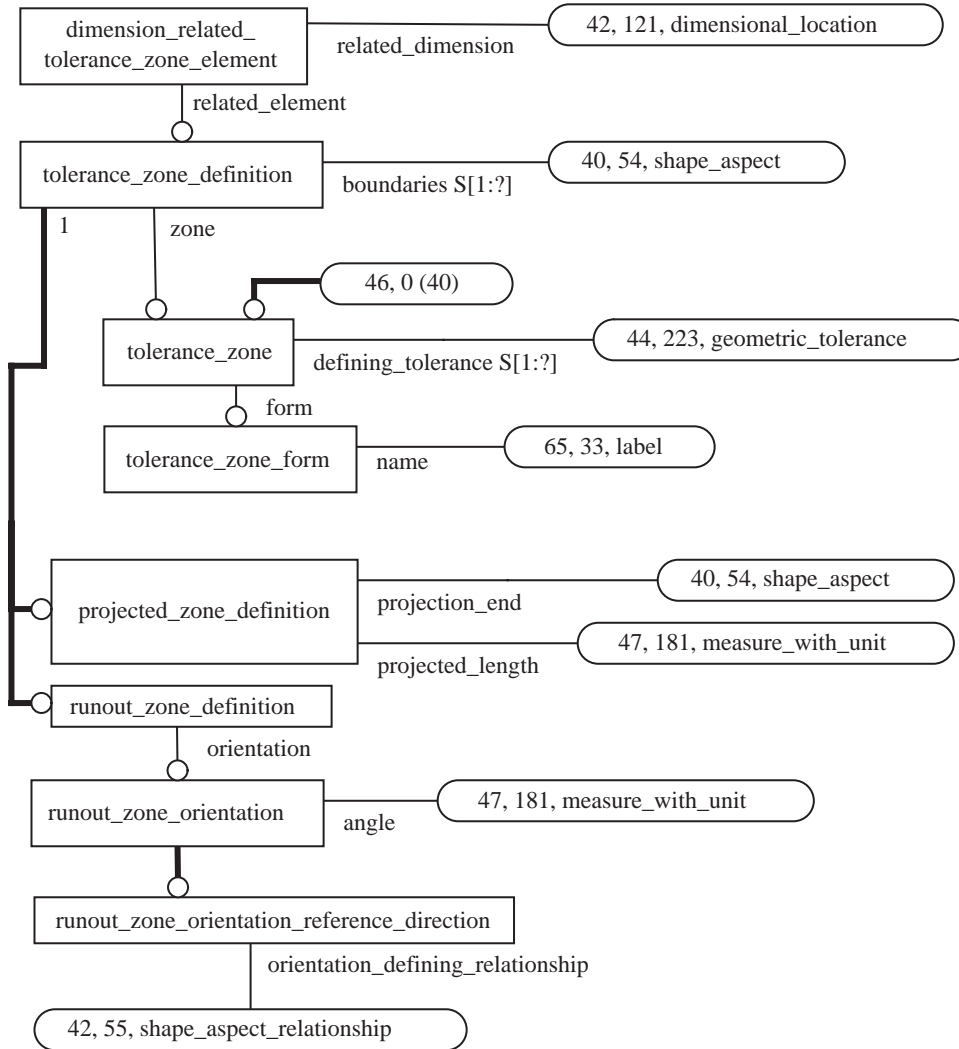


Figure H.44 — AIM EXPRESS-G diagram geometric tolerance

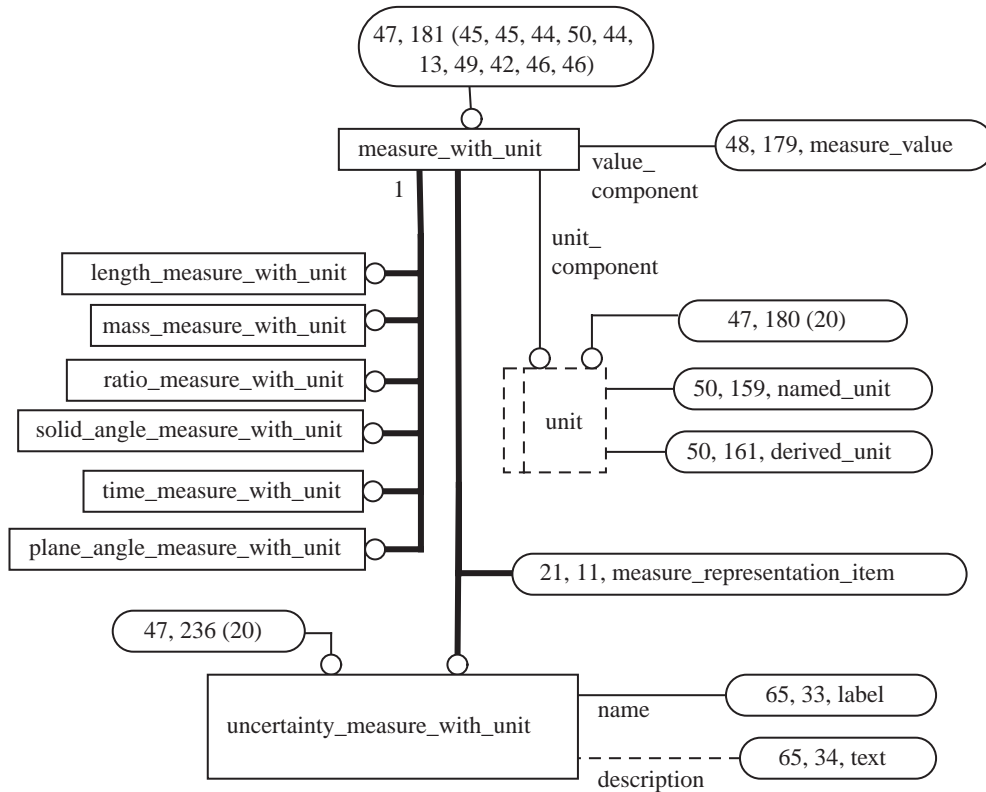


**Figure H.45 — AIM EXPRESS-G diagram dimensional size**

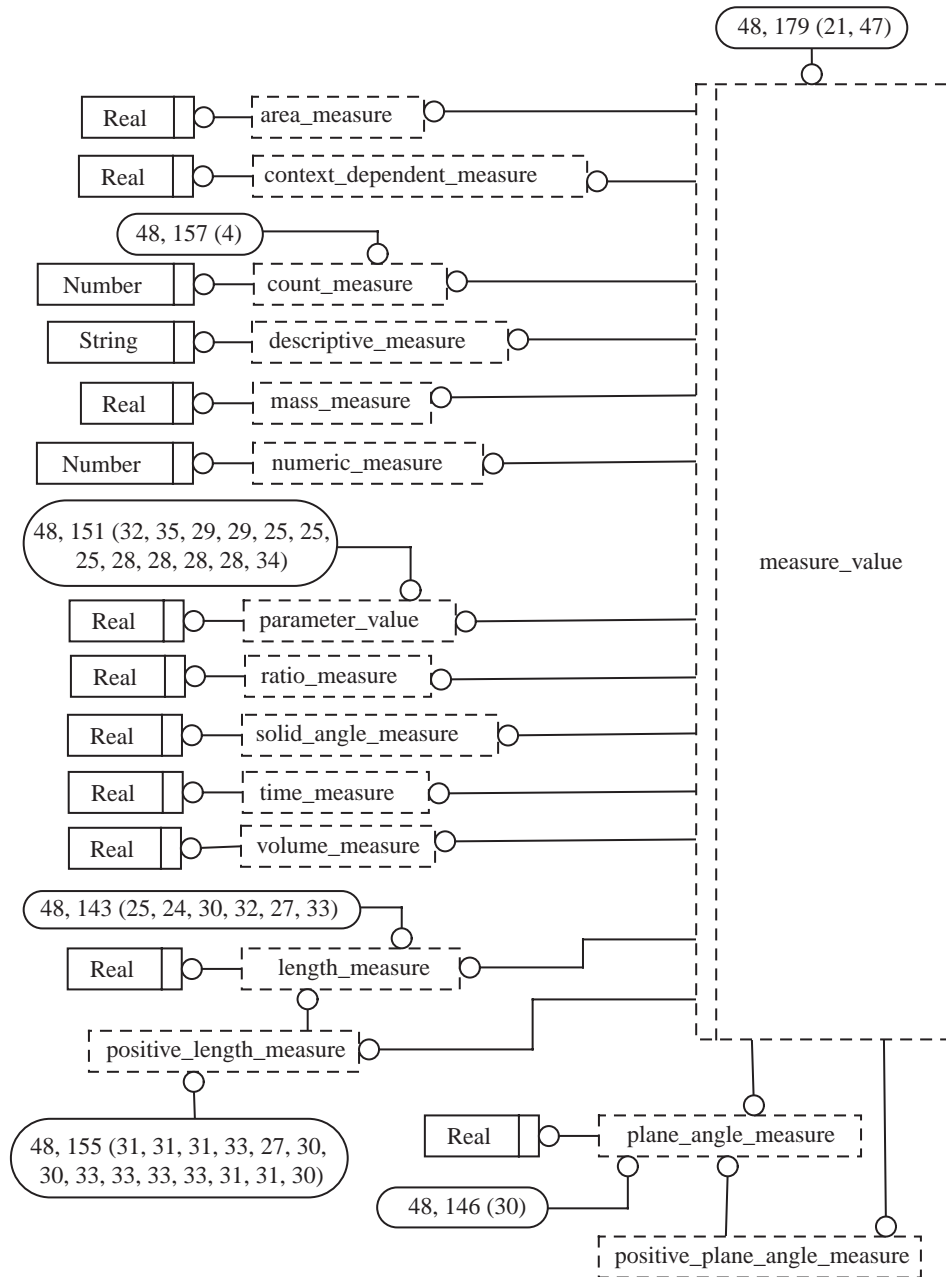


**Figure H.46 — AIM EXPRESS-G diagram tolerance zone**

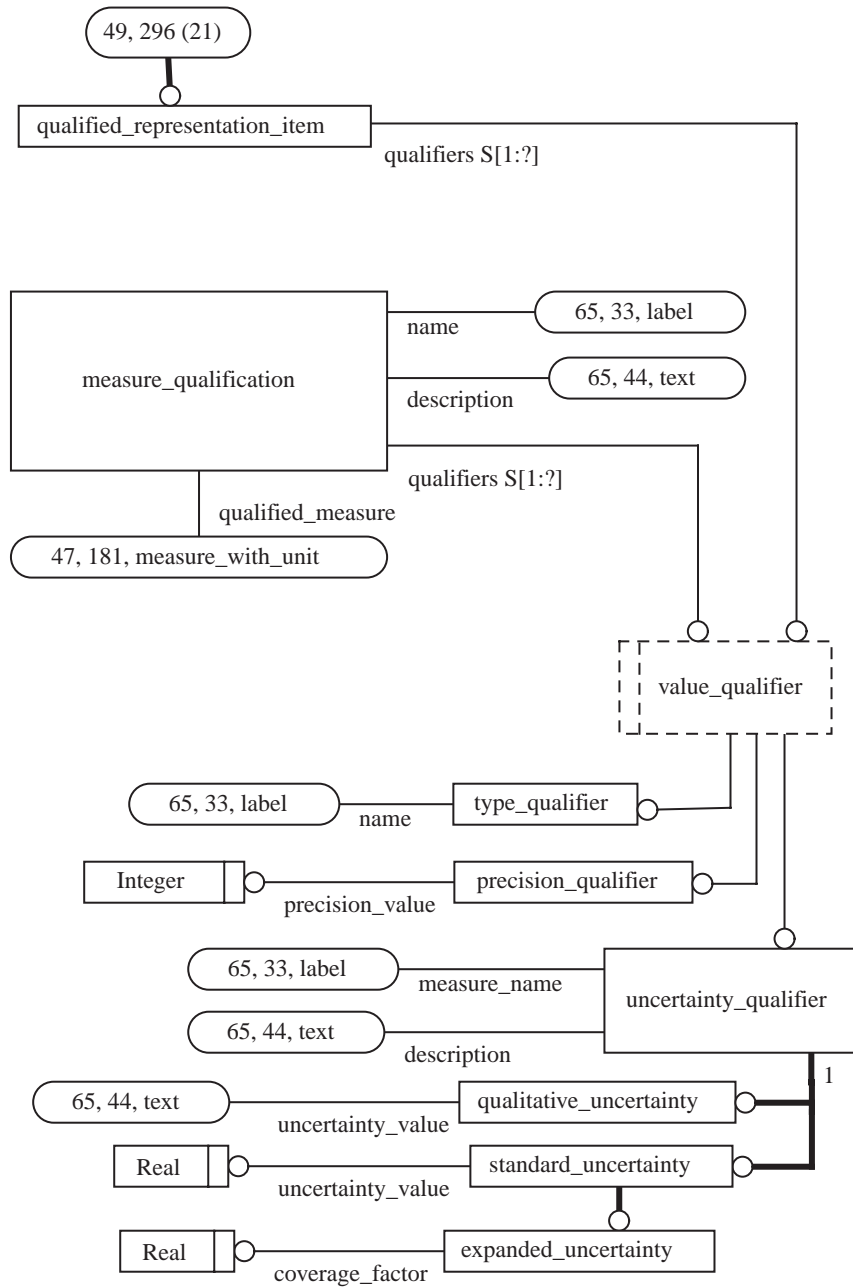




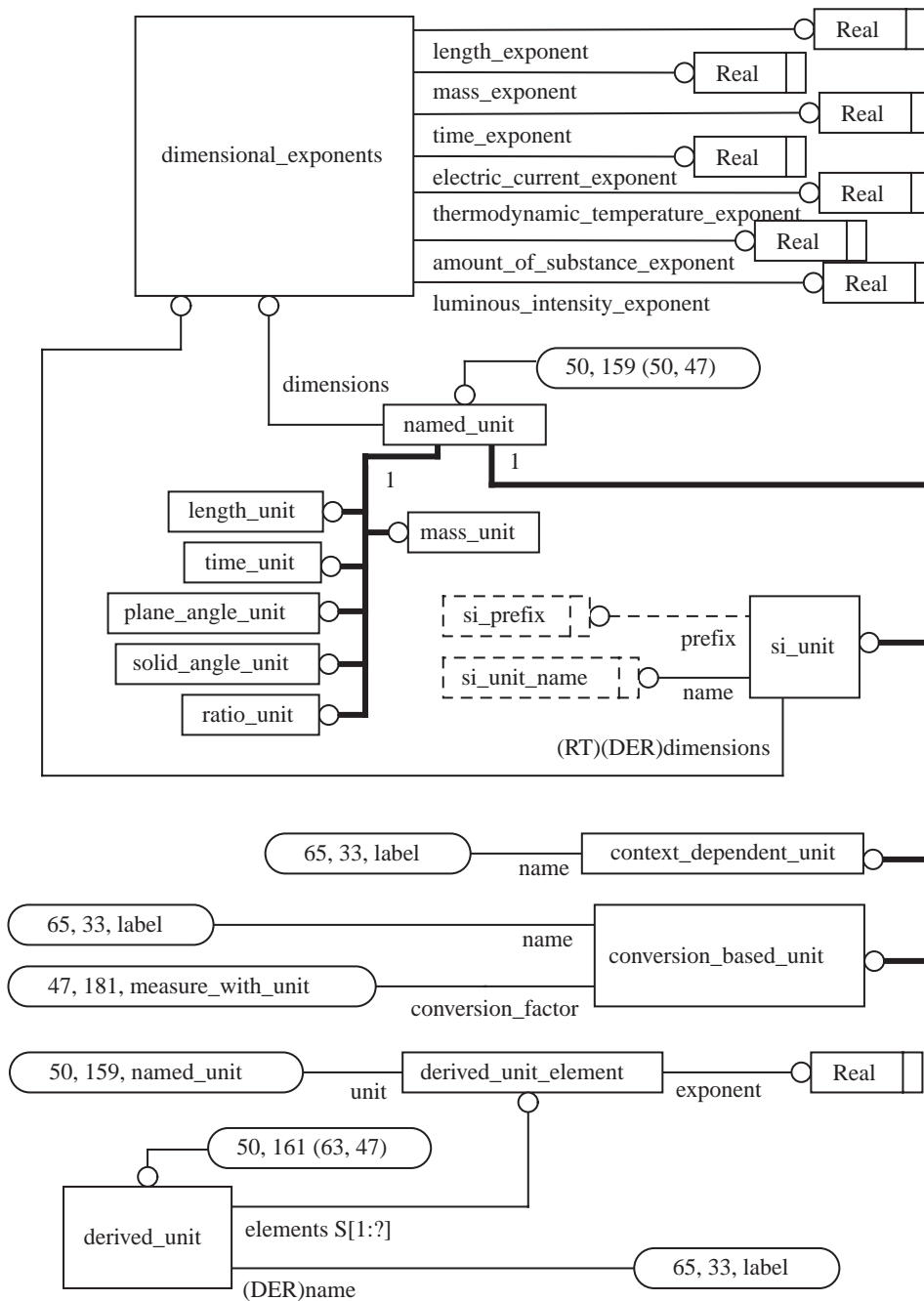
**Figure H.47 — AIM EXPRESS-G diagram measure with unit**



**Figure H.48 — AIM EXPRESS-G diagram measure value**



**Figure H.49 — AIM EXPRESS-G diagram qualified representation item**



**Figure H.50 — AIM EXPRESS-G diagram unit**

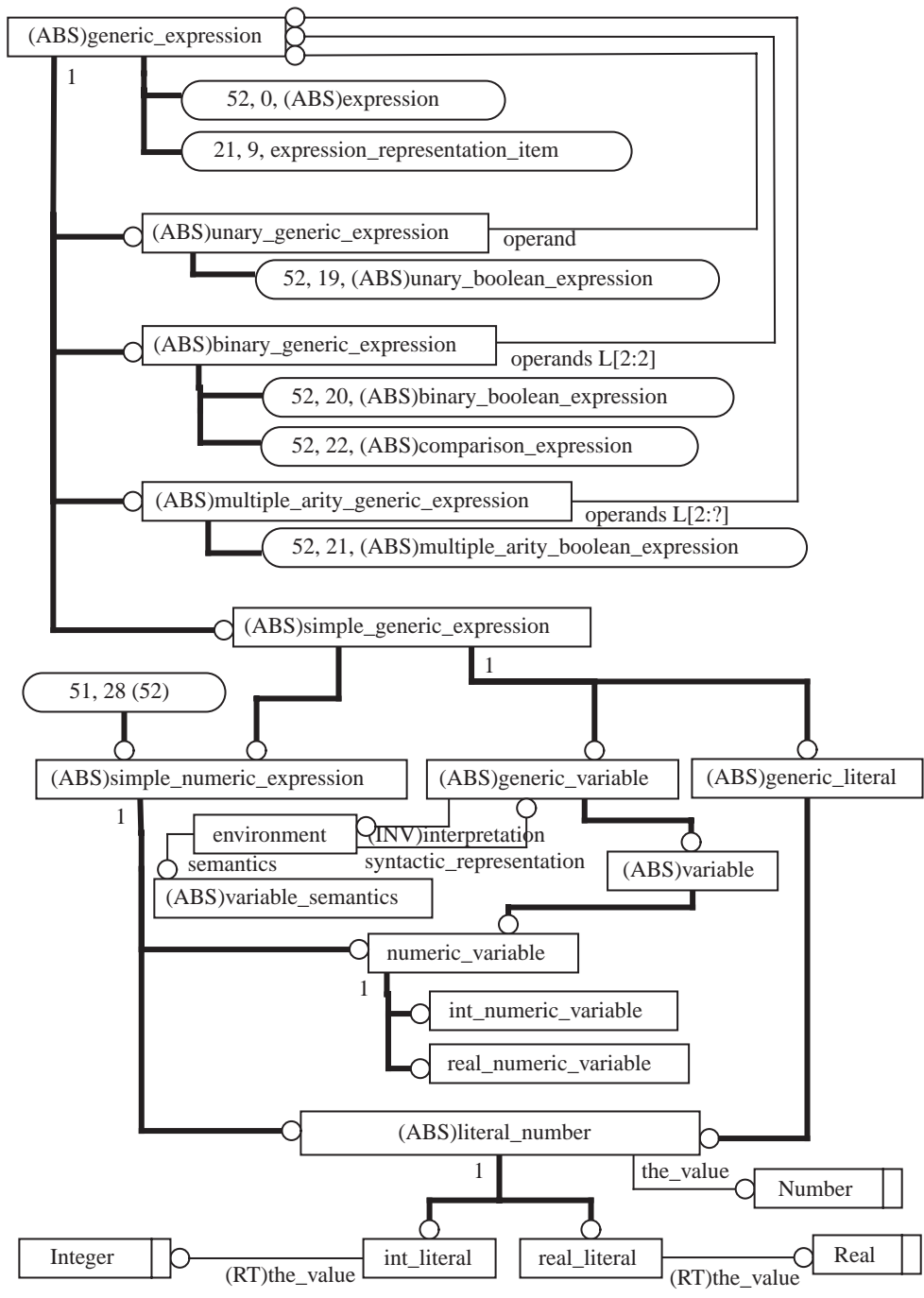


Figure H.51 — AIM EXPRESS-G diagram generic expression

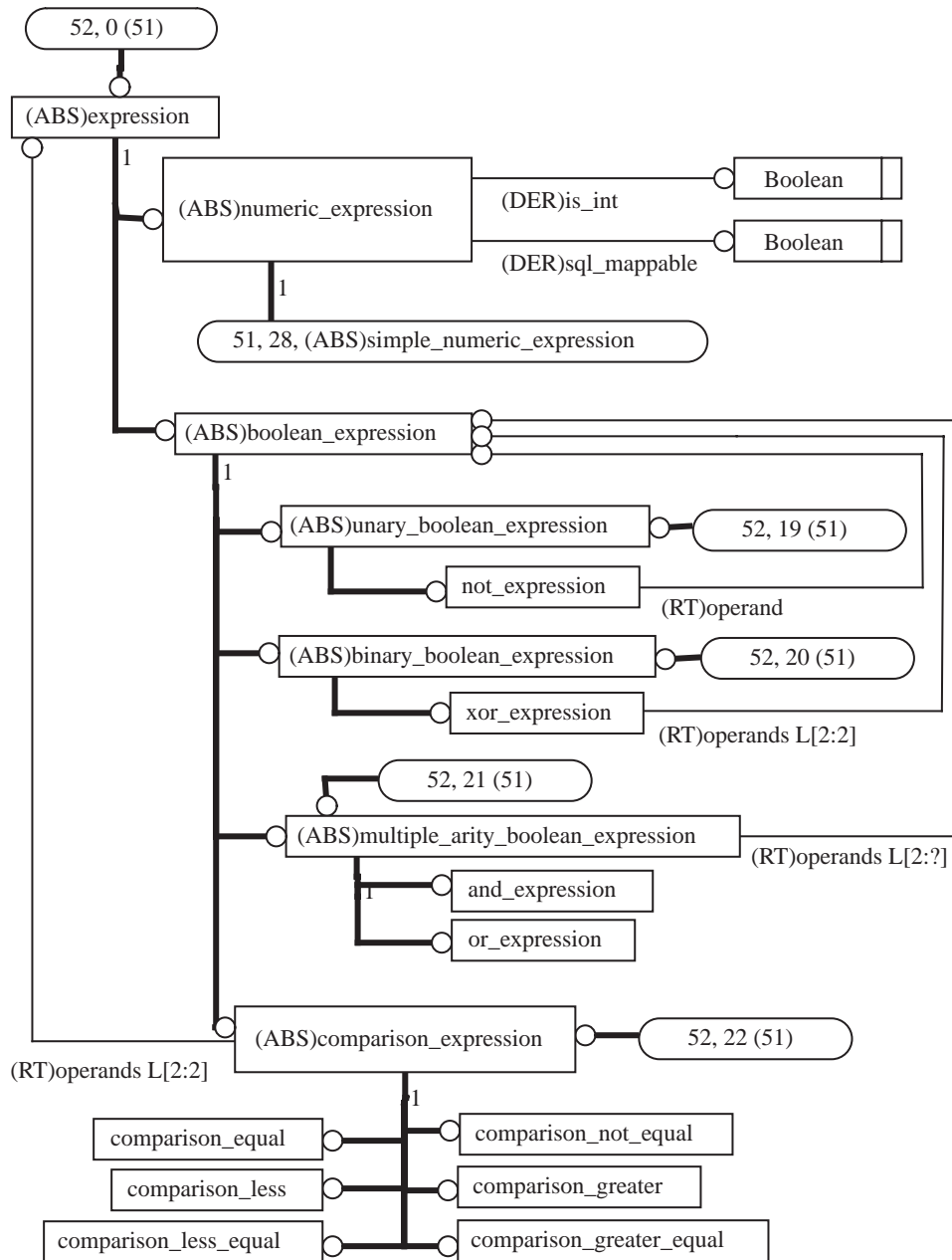
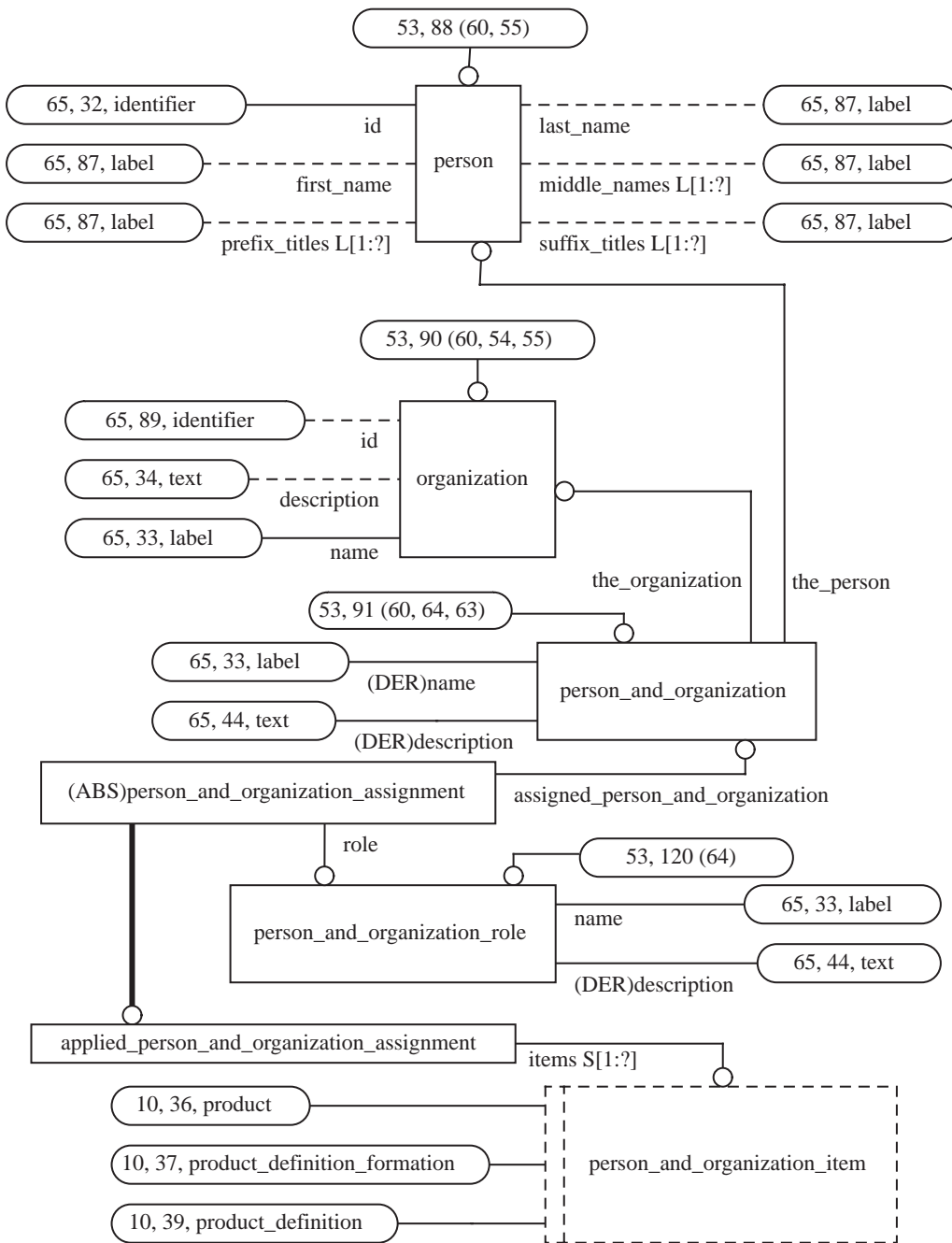
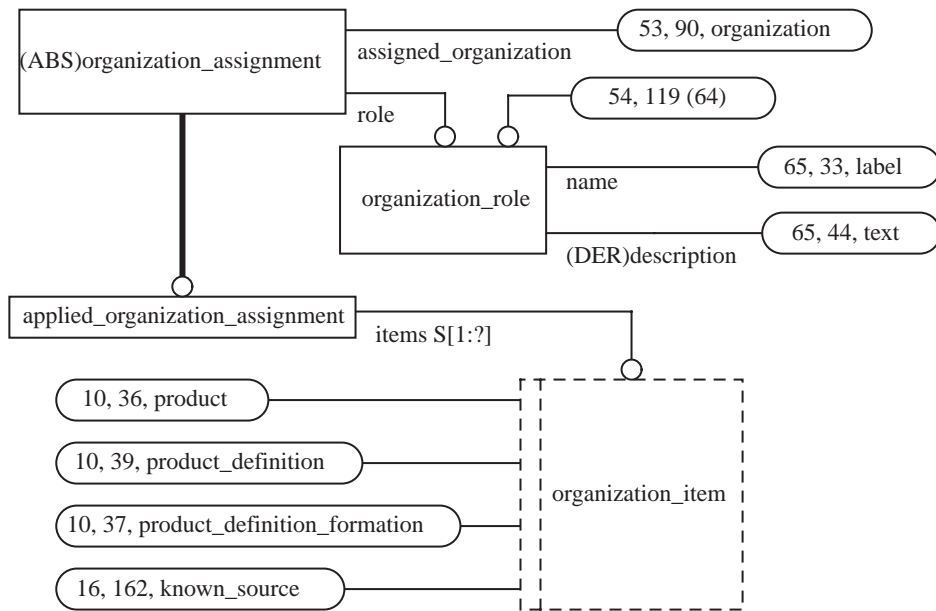


Figure H.52 — AIM EXPRESS-G diagram expression

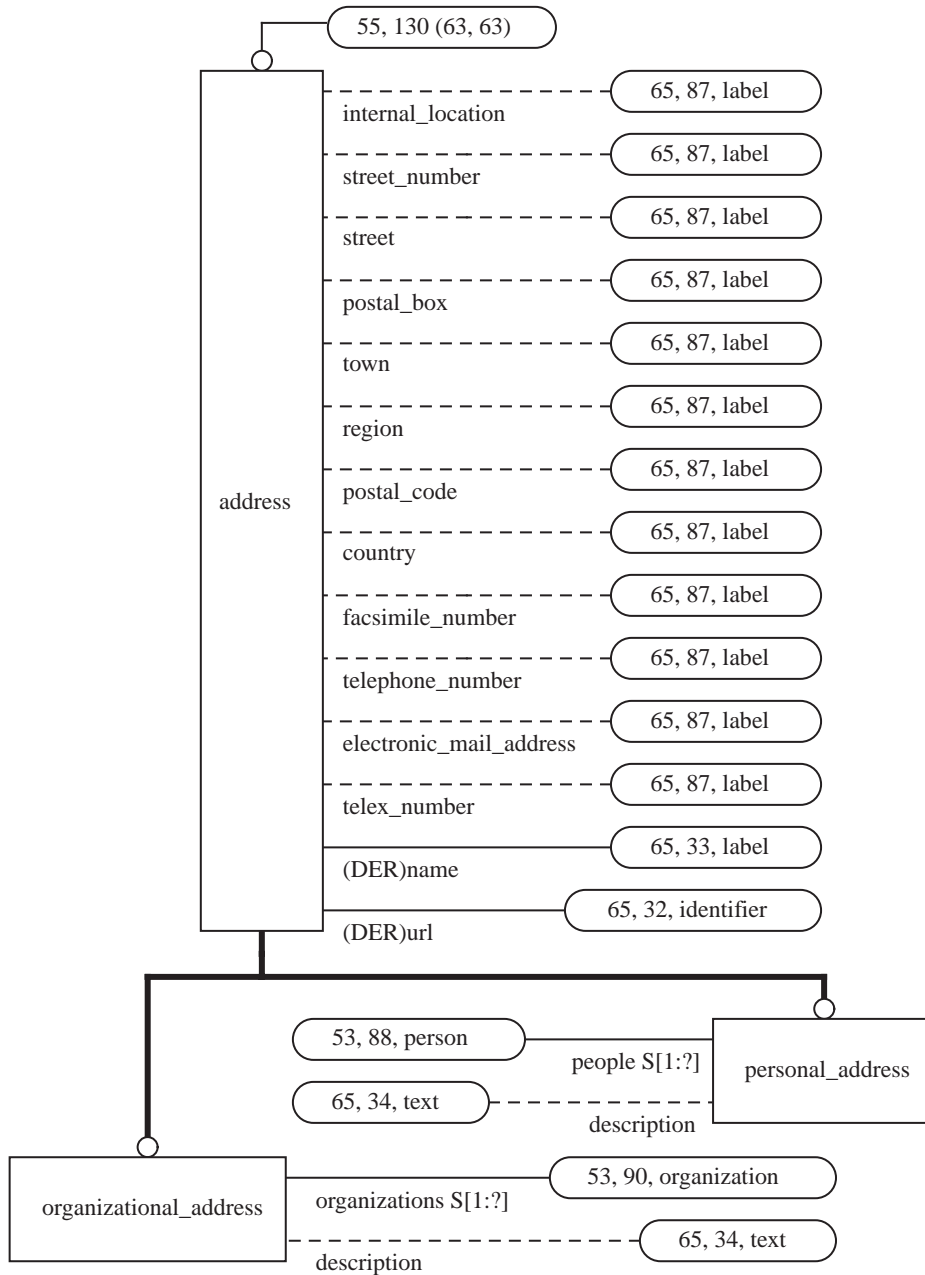


**Figure H.53 — AIM EXPRESS-G diagram person and organization**

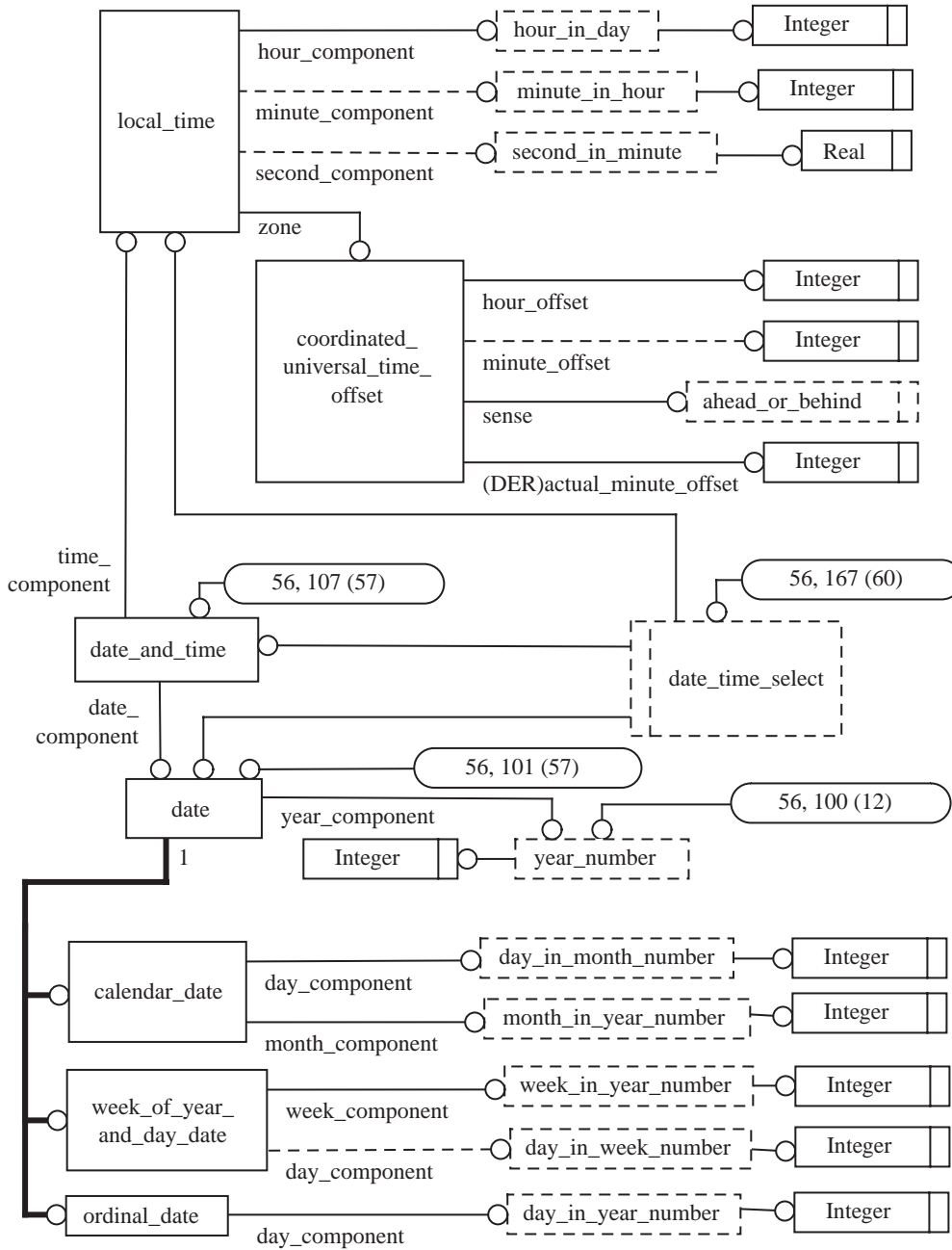


**Figure H.54 — AIM EXPRESS-G diagram organization assignment**

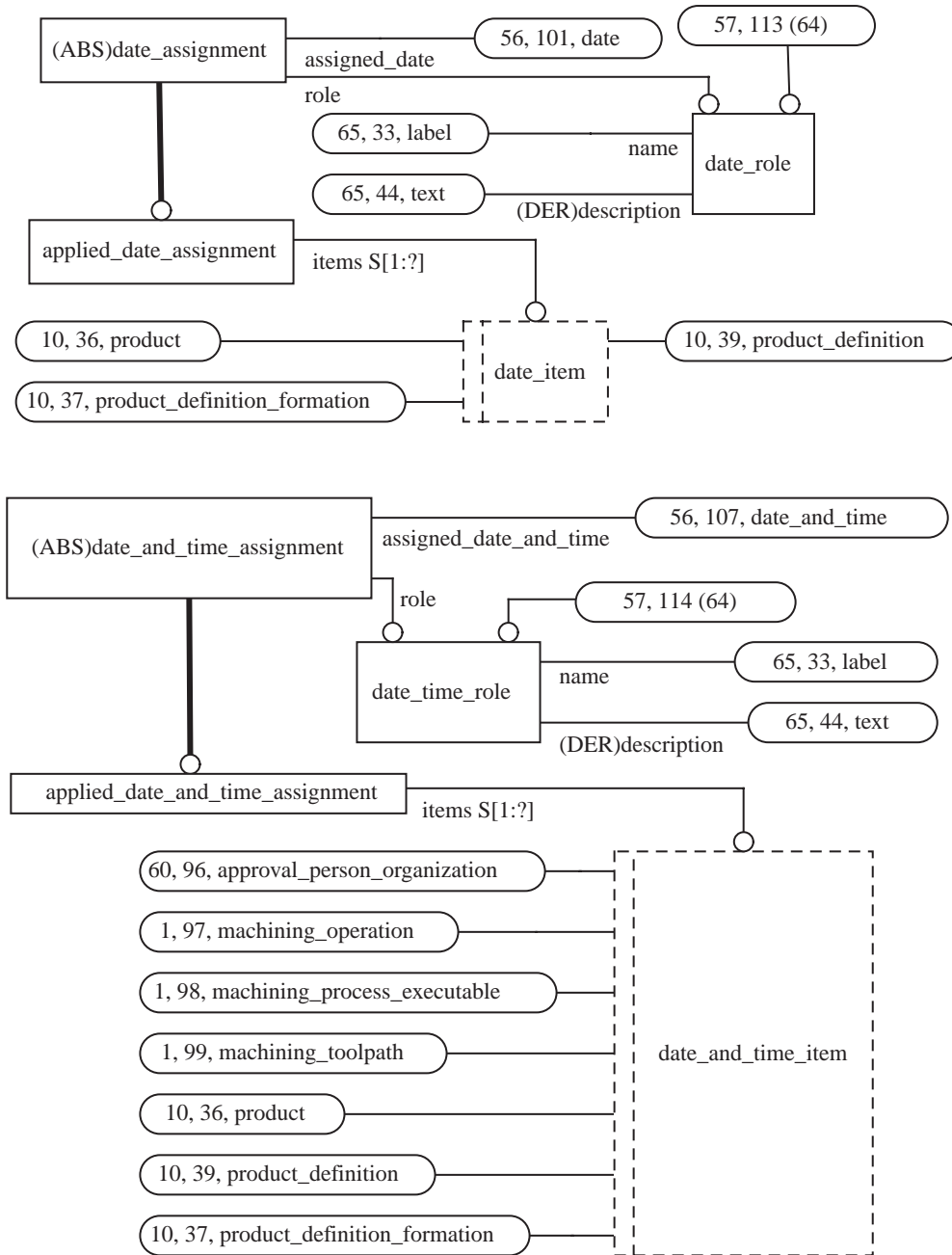




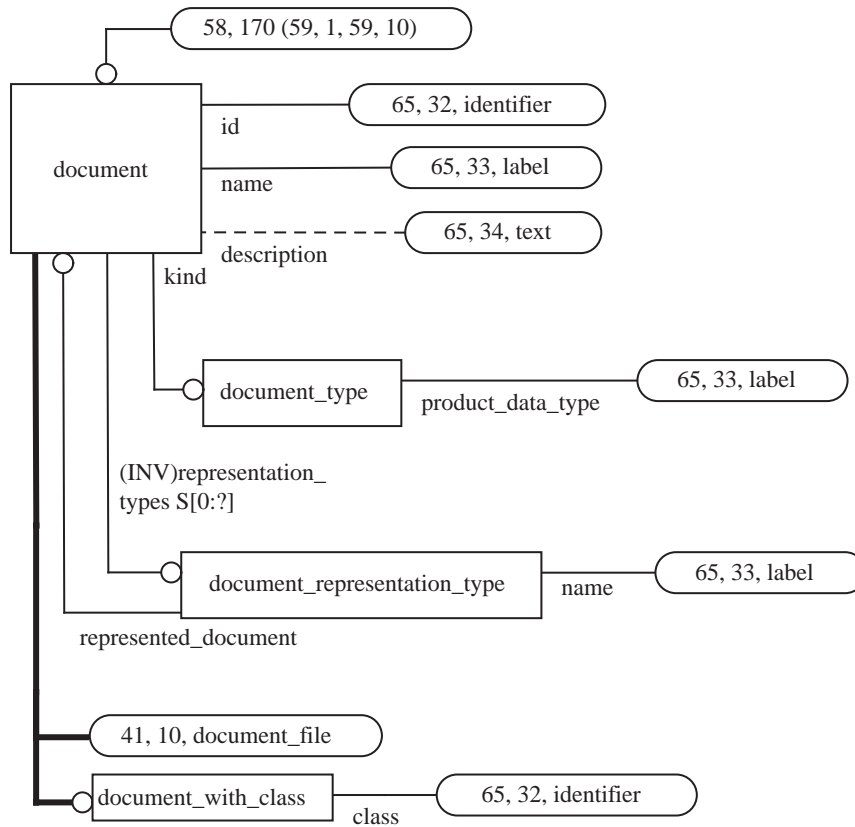
**Figure H.55 — AIM EXPRESS-G diagram address**



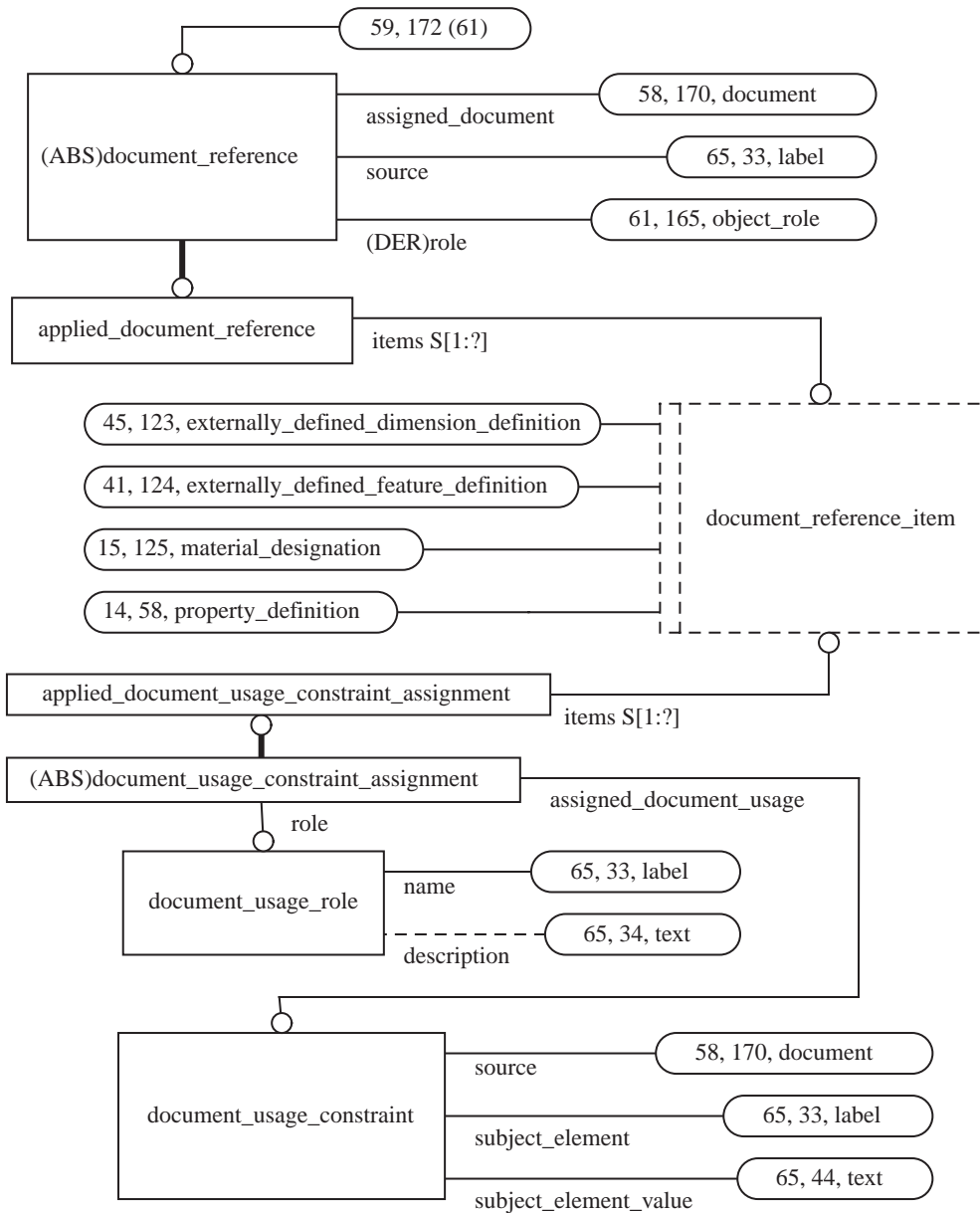
**Figure H.56 — AIM EXPRESS-G diagram date and time**



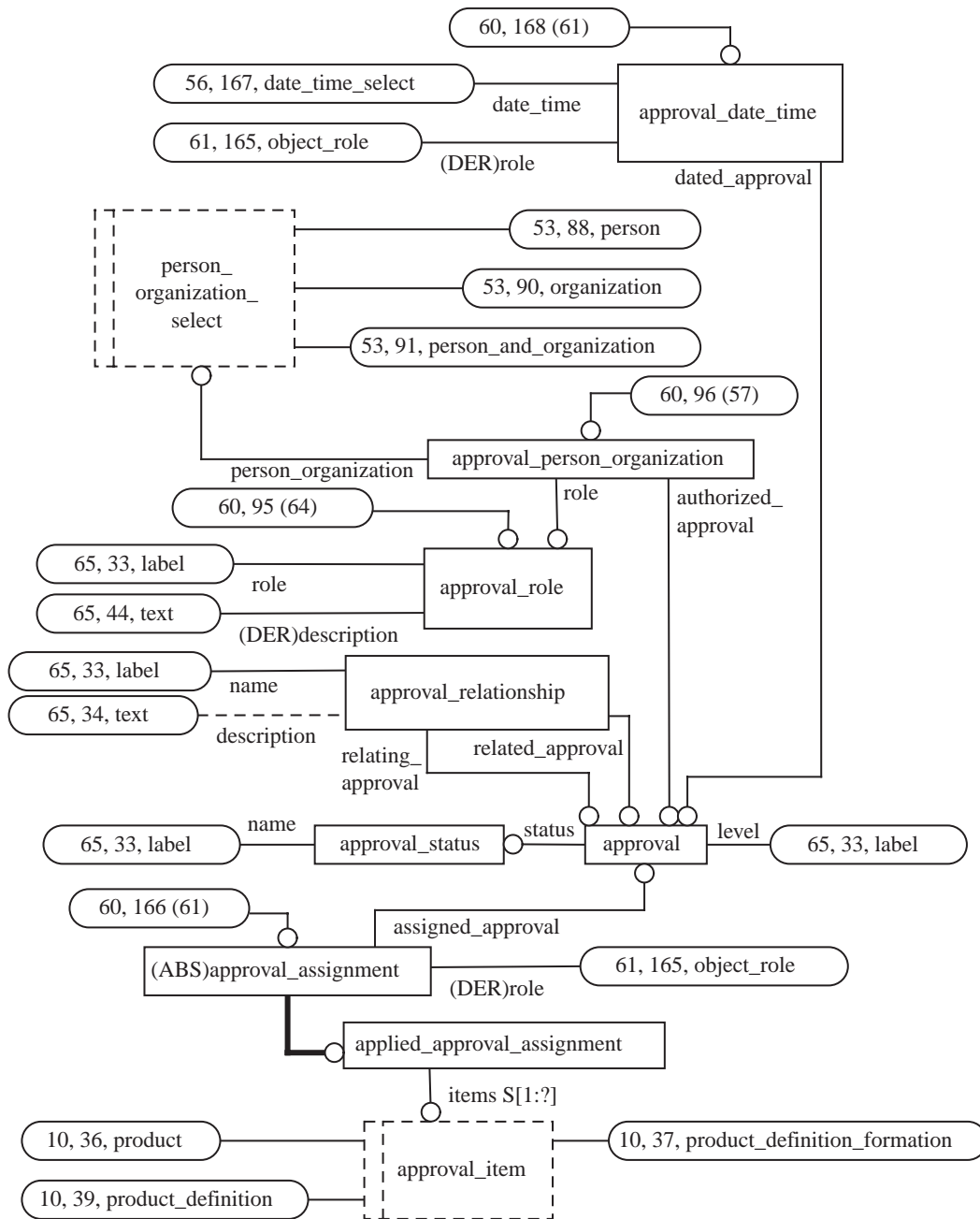
**Figure H.57 — AIM EXPRESS-G diagram date and time assignment**



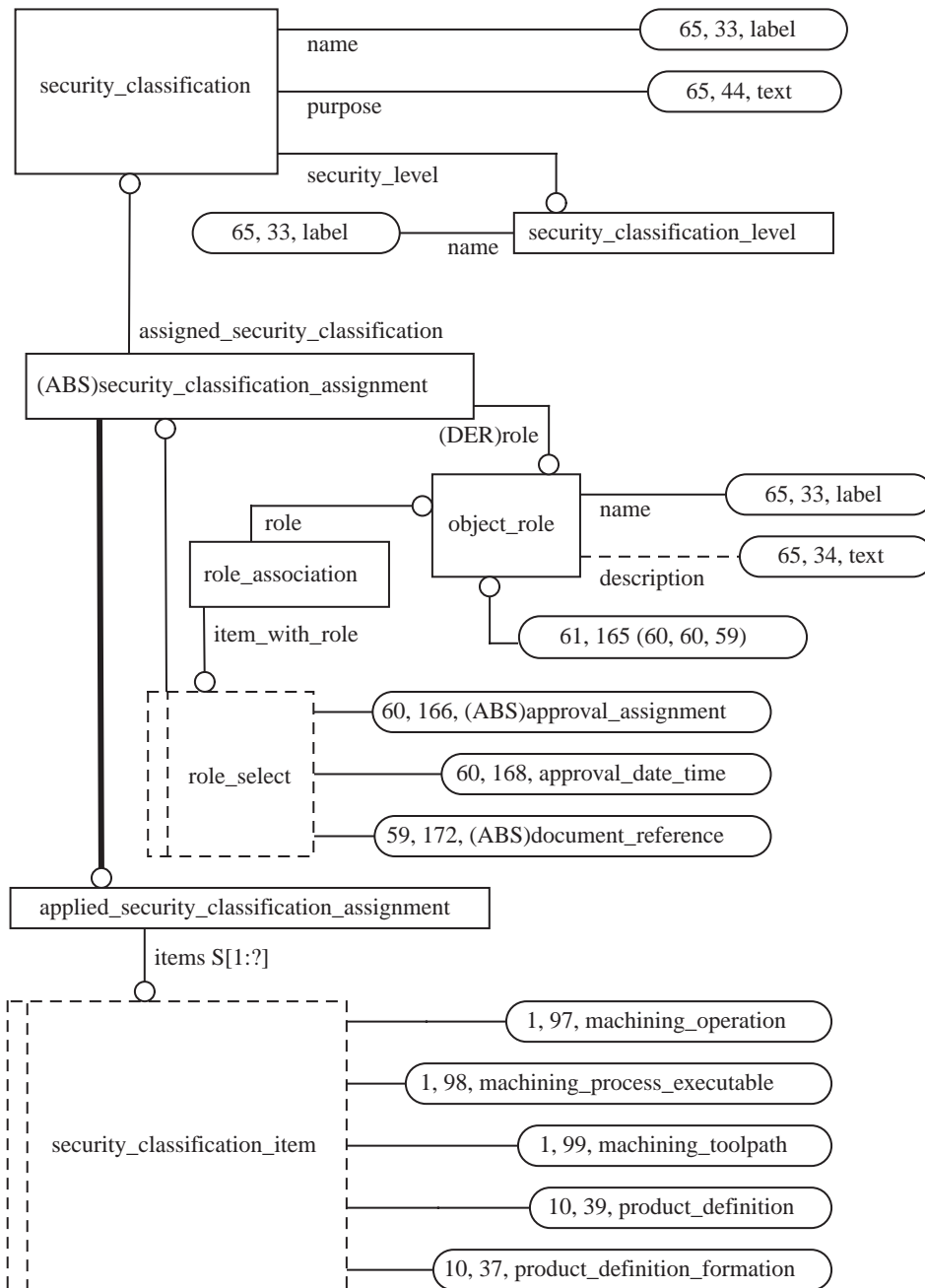
**Figure H.58 — AIM EXPRESS-G diagram document**



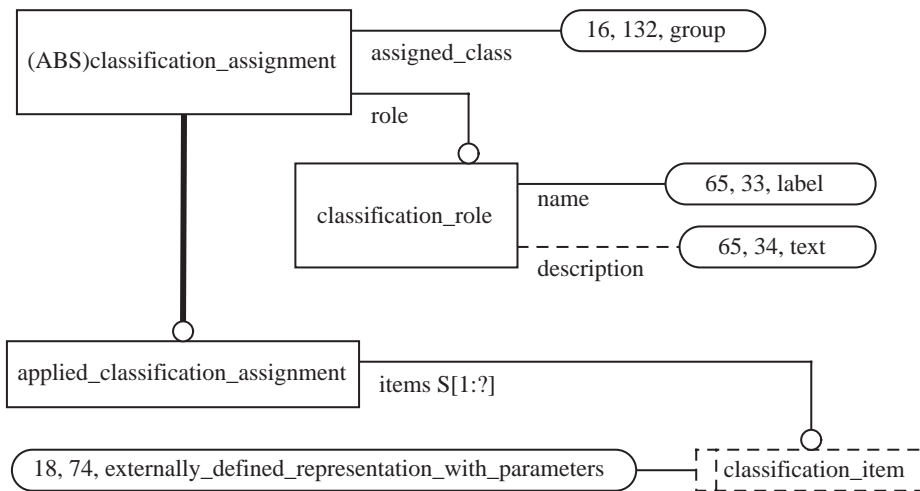
**Figure H.59 — AIM EXPRESS-G diagram document reference**



**Figure H.60 — AIM EXPRESS-G diagram approval**

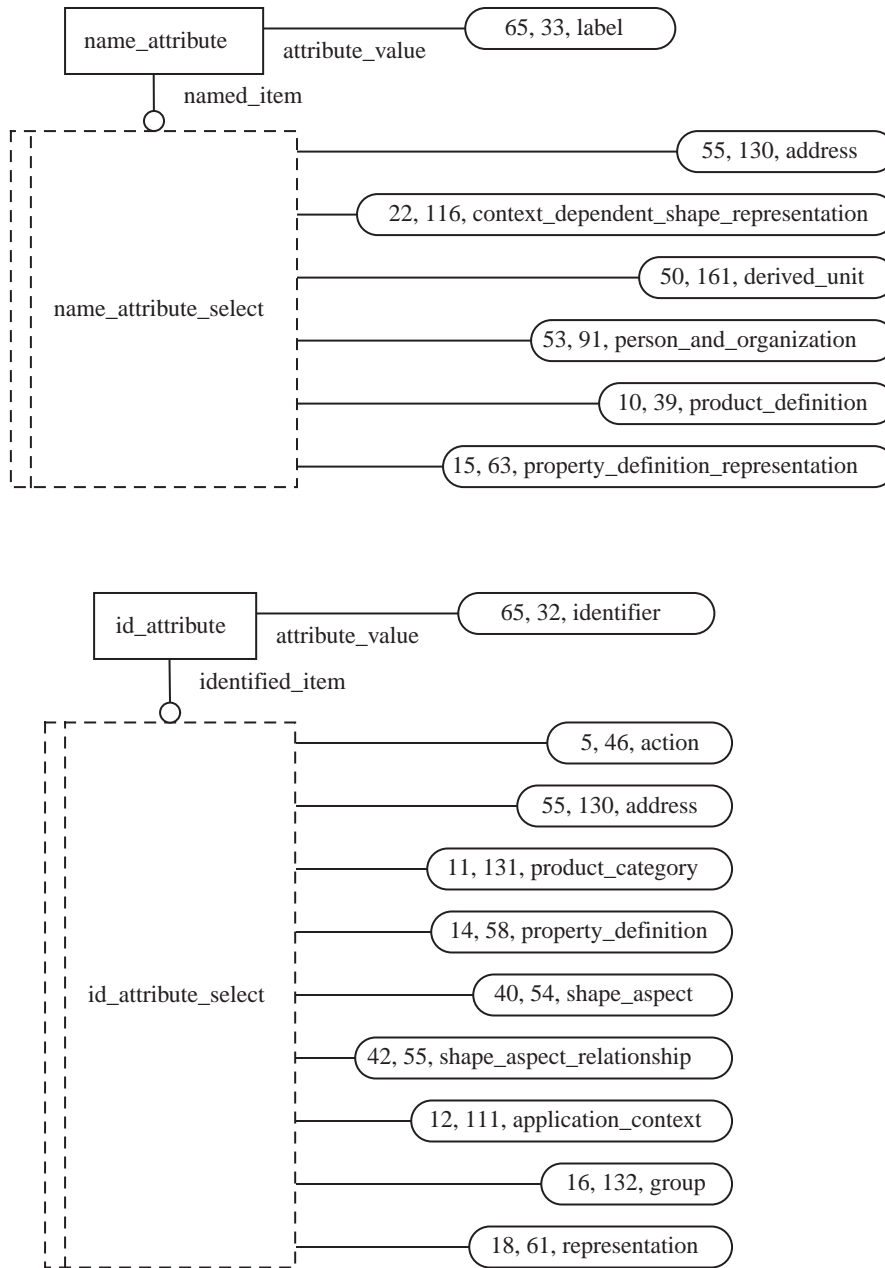


**Figure H.61 — AIM EXPRESS-G diagram security classification**

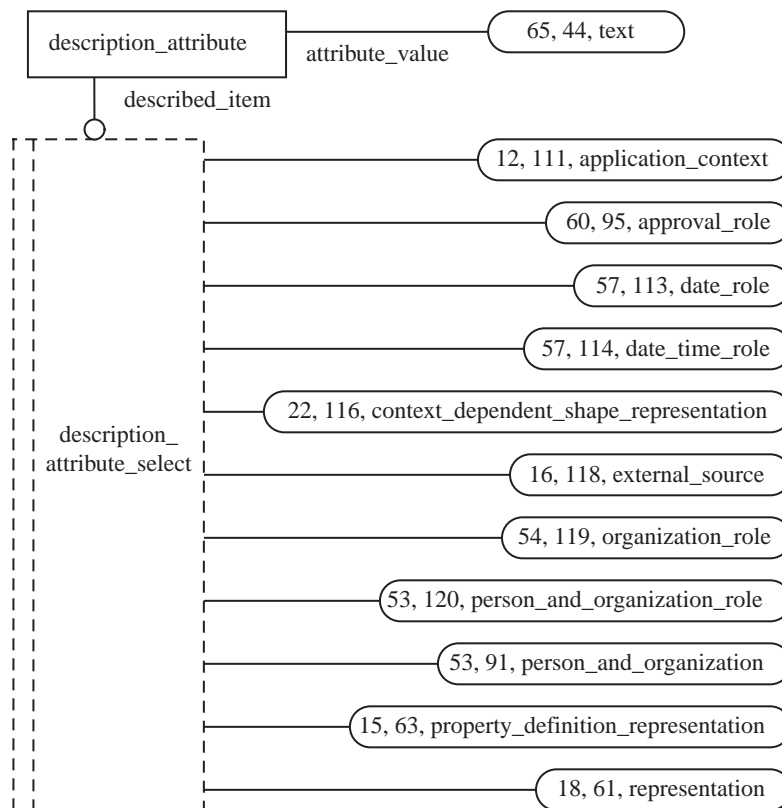


**Figure H.62 — AIM EXPRESS-G diagram classification assignment**





**Figure H.63 — AIM EXPRESS-G diagram name and id attribute**



**Figure H.64 — AIM EXPRESS-G diagram description attribute**

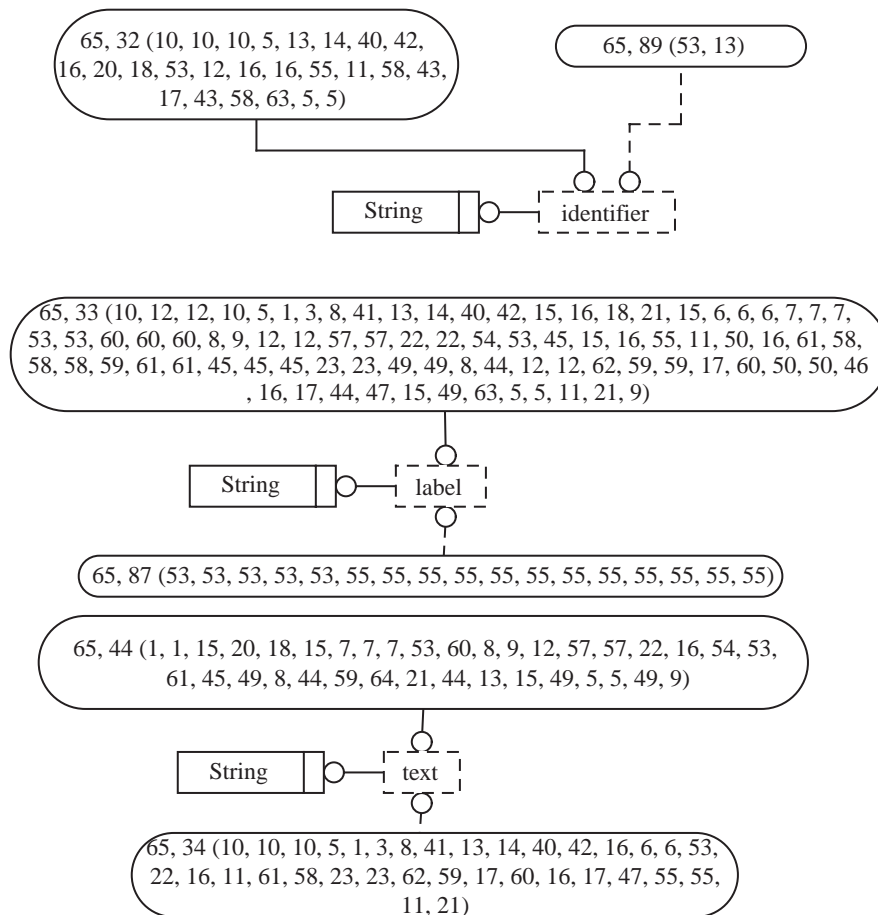


Figure H.65 — AIM EXPRESS-G diagram additional types

## **Annex I** (informative)

### **Computer interpretable listings**

This annex references a listing of the complete EXPRESS schema specified in Annex A of this part of ISO 10303 without comments or other explanatory text. It also references a listing of the EXPRESS entity names and corresponding short names as specified in Annex B of this part of ISO 10303. The content of this annex is available in computer-interpretable form and can be found at the following URLs:

Short names: [http://www.tc184-sc4.org/short\\_names](http://www.tc184-sc4.org/short_names)

EXPRESS: <http://www.tc184-sc4.org/express>

If there is difficulty accessing these sites contact ISO Central Secretariat or contact the ISO TC 184/SC4 Secretariat directly at: [sc4sec@cme.nist.gov](mailto:sc4sec@cme.nist.gov).

NOTE The information provided in computer-interpretable form at the above URLs is informative. The information that is contained in the body of this part of ISO 10303 is normative.

[Blank page]

## Annex J (informative)

### Annotated examples

#### J.1 Introduction

This annex provides four example data sets to assist implementors in understanding the use and structure of this part of ISO 10303. The examples have been annotated with comments to illustrate the relationship between the application object concepts documented in 4.2 and the AIM instances organized according to the mapping paths documented in 5.1.

The first data set is a conformance class one example that describes a simple workplan for milling a block using explicit toolpaths. The second is a conformance class two example that adds workpiece and stock geometry descriptions to the first example. The third is a conformance class three example that describes a milling workplan for several features on a block. This was adapted from an ARM example that appears in ISO 14649-11. The fourth is a conformance class three example that describes a turning workplan for several features on a workpiece. This was adapted from an ARM example that appears in ISO 14649-12.

#### J.2 Annotation conventions

Each data set is described as an ISO 10303-21 exchange structure. The AIM instances are grouped by ARM application object with a comment at the beginning of each block show how the instances are arranged to describe the application object and associated parameters.

**EXAMPLE** The instances below represent a Milling\_machine\_functions application object.

```

/*****
 * Application object: MILLING_MACHINE_FUNCTIONS (#50)
 * THROUGH_SPINDLE_COOLANT: #50, #51, #52, #53, #54: [through spindle coolant off]
 * CHIP_REMOVAL: #50, #55, #56, #57, #58: [chip removal off]
 * COOLANT: #50, #59, #60, #61, #62: [coolant on]
 */
#50=MACHINING_FUNCTIONS('', 'milling', ' ', ' ');

#51=ACTION_PROPERTY('through spindle coolant', '', #50);
#52=ACTION_PROPERTY_REPRESENTATION('', '', #51, #53);
#53=REPRESENTATION('', (#54), #31);
#54=DESCRIPTIVE_REPRESENTATION_ITEM('constant', 'through spindle coolant off');

#55=ACTION_PROPERTY('chip removal', '', #50);
#56=ACTION_PROPERTY_REPRESENTATION('', '', #55, #57);
#57=REPRESENTATION('', (#58), #31);
#58=DESCRIPTIVE_REPRESENTATION_ITEM('constant', 'chip removal off');

#59=ACTION_PROPERTY('coolant', '', #50);
#60=ACTION_PROPERTY_REPRESENTATION('', '', #59, #61);
#61=REPRESENTATION('', (#62), #31);
#62=DESCRIPTIVE_REPRESENTATION_ITEM('constant', 'coolant on');

```

In the example above, the first line of the comment indicates that the instances describe a Milling\_machine\_functions application object. In parenthesis, instance #50 is identified as the AIM element for the application object and the starting instance for the reference paths given in the mapping tables.

In Table 8, the mapping table entry for Milling\_machine\_functions calls for an AIM element of type machining\_functions and the reference path shown below:

```

machining_functions <=
  action_method
  { action_method.description = 'milling' }

```

Instance #50 is the machining\_functions instance at the start of the reference path. The second line simply states that machining\_functions is a subtype of action\_method. The final line of the path states that the description attribute has the value “milling.” In instance #50, the second attribute (which the description attribute in ISO 10303-21 syntax) is indeed “milling.”

The rest of the comment indicates application object parameters and AIM instances that form the reference path given in the mapping tables. Consider the Milling\_machine\_functions coolant parameter and the corresponding reference path from Table 8:

```

machining_functions <=
  action_method
  characterized_action_definition = action_method
  characterized_action_definition <-
    action_property.definition
    { action_property.name = 'coolant' }
    action_property <-
      action_property_representation.property
      action_property_representation
      action_property_representation.representation ->
        representation
        representation.items[i] ->
          representation_item =>
            descriptive_representation_item
            descriptive_representation_item.description
            { (descriptive_representation_item.description = 'coolant on' )
              (descriptive_representation_item.description = 'coolant off' ) }

```

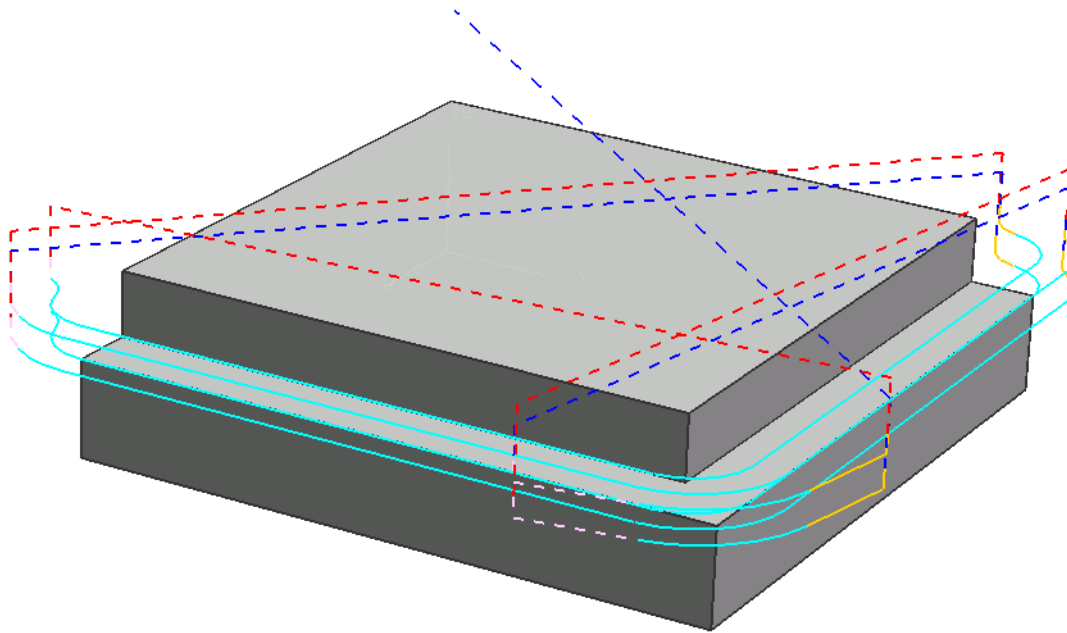
The comment indicates that #50, #59, #60, #61, and #62 describe the coolant parameter. Instance #50 is the machining\_functions instance at the start of the reference path. This is referred to by #59, an action property with a name of “coolant.” This action\_property is referred to by #60, which is an action\_property\_representation. This refers to #61, which is a representation that contains descriptive\_representation\_item #62 in its items set. The last lines of the reference path constrain the value of the description attribute to either “coolant on” or “coolant off.” In instance #62, the value is “coolant on,” which is also documented at the end of the comment. This can seem verbose, but implementation tests have shown that in normal use, almost all data in a file will be geometry instances that describe either workpiece shape or toolpath curves.

It is hoped that this annotation will assist implementors in understanding the use and structure of the application objects, mapping reference paths, and corresponding integrated representation for the examples that follow.

### J.3 Machining project for CC1 and CC2 examples

The first two examples describe a machining project with a single workplan and single workingstep. The workplan specifies explicit toolpaths to mill a simple block as shown in Figure J.1.

The workpiece for the project is a block 100mm square and 25mm high, with a 10mm wide by 10mm high step along two sides. The rawpiece is a block 100mm square and 25mm high. The origin is at the bottom of the part, on the corner opposite both steps. The toolpath was generated for a 20mm end-mill and starts at (0,0,40). The dashed toolpaths shown in Figure J.1 specify rapid feed and the solid toolpaths specify a feedrate of 250 mm/min.



**Figure J.1 — Example workpiece and toolpath**

The example in J.4 is a conformance class one data set and contains only the machining workplan and toolpaths. The example in J.5 is a conformance class two data set, and contains the machining workplan, toolpaths, rawpiece geometry, and workpiece geometry.

### J.4 Data set for CC1 example

The example below is a conformance class one (CC1) data set for the project described in J.3. This describes a machining workplan with one workingstep. The workingstep refers to a freeform milling operation which contains twelve cutter location toolpath segments.

```
ISO-10303-21;
HEADER;

FILE_DESCRIPTION (
```



```

/* description */ ('AP238 CC1 simple block example'),
/* implementation_level */ '2;1');

FILE_NAME(
/* name */ 'simple_block_cc1',
/* time_stamp */ '2006-07-06T11:54:14-04:00',
/* author */ ('Dave Loffredo (loffredo@steptools.com)'),
/* organization */ (''),
/* preprocessor_version */ 'ST-DEVELOPER v11',
/* originating_system */ 'Various',
/* authorisation */ '');

FILE_SCHEMA (('INTEGRATED_CNC_SCHEMA'));
ENDSEC;

DATA;

/*****
* Application object: PROJECT (#10)
* MAIN_WORKPLAN: #10, #11, #12, #575
* ITS_ID: #10, #13, #14 ['New Project']
* ITS_WORKPIECES [*]: #10, #15, #19
*/
#10=PRODUCT_DEFINITION('','',#13,#16);
#11=PROCESS_PRODUCT_ASSOCIATION('','',#10,#12);
#12=PRODUCT_DEFINITION_PROCESS('machining','',#575,'');
#13=PRODUCT_DEFINITION_FORMATION('','',#14);
#14=MACHINING_PROJECT('New Project','',$(#18));
#15=MACHINING_PROJECT_WORKPIECE_RELATIONSHIP('','workpiece','',#10,#19);
#16=PRODUCT_DEFINITION_CONTEXT('CNC Machining',#17,'manufacturing');
#17=APPLICATION_CONTEXT(
'Application protocol for the exchange of CNC data');
#18=PRODUCT_CONTEXT('CNC Machining',#17,'manufacturing');

/*****
* Application object: WORKPIECE (#19)
* ITS_ID: #19 ['unnamed workpiece']
* SHAPE_DEFINITION: #19, #20
*/
#19=PRODUCT_DEFINITION('unnamed workpiece','',#21,#16);
#20=PRODUCT_DEFINITION_SHAPE('','',#19);
#21=PRODUCT_DEFINITION_FORMATION('1.0','Workpiece',#22);
#22=PRODUCT('WP','AP-238 CC1','',$(#18));

/*****
* Application object: CUTTER_LOCATION_TRAJECTORY (#23)
* ITS_TYPE: #23, #24, #25, #26, #27 ['trajectory path']
* ITS_TECHNOLOGY: #23, #28, #528
* ITS_PRIORITY: #23, #29, #30, #31, #32 ['required']
* RAPID_SPEED: #23, #33, #34, #35, #36 ['true']
* ITS_ID: #23 ['WS 1 TP 1']
* BASICCURVE: #23, #37, #38, #39, #40
*/
#23=MACHINING_TOOLPATH('WS 1 TP 1','cutter location trajectory','',');

```

```

#24=ACTION_PROPERTY('trajectory type','cutter location trajectory',#23);
#25=ACTION_PROPERTY_REPRESENTATION('','cutter location trajectory',#24,#26);
#26=REPRESENTATION('constant',(#27),#41);
#27=DESCRIPTIVE_REPRESENTATION_ITEM('constant','trajectory path');
#28=MACHINING_TECHNOLOGY_RELATIONSHIP('','cutter location trajectory',#23,
#528);
#29=ACTION_PROPERTY('priority','cutter location trajectory',#23);
#30=ACTION_PROPERTY_REPRESENTATION('','cutter location trajectory',#29,#31);
#31=REPRESENTATION('constant',(#32),#41);
#32=DESCRIPTIVE_REPRESENTATION_ITEM('constant','required');
#33=ACTION_PROPERTY('speed profile','rapid',#23);
#34=ACTION_PROPERTY_REPRESENTATION('','rapid',#33,#35);
#35=MACHINING_TOOLPATH_SPEED_PROFILE_REPRESENTATION('',(#36),#41);
#36=DESCRIPTIVE_REPRESENTATION_ITEM('','rapid');
#37=ACTION_PROPERTY('basic curve','cutter location trajectory',#23);
#38=ACTION_PROPERTY_REPRESENTATION('','cutter location trajectory',#37,#39);
#39=REPRESENTATION('',(#40),#42);
#40=POLYLINE('basic curve for WS 1 TP 1',(#44,#45,#46));
#41=REPRESENTATION_CONTEXT('','units not necessary');
#42=(
GEOMETRIC_REPRESENTATION_CONTEXT(3)
GLOBAL_UNIT_ASSIGNED_CONTEXT((#554,#551,#558))
REPRESENTATION_CONTEXT('MILLIMETRE DEGREE STERADIAN','')
);
#44=CARTESIAN_POINT('start point',(0.,0.,40.));
#45=CARTESIAN_POINT('',(76.6078,112.6997,28.));
#46=CARTESIAN_POINT('',(76.6078,112.6997,23.));

/*****
* Application object: CUTTER_LOCATION_TRAJECTORY (#47)
* ITS_TYPE: #47, #48, #49, #26, #27 ['trajectory path']
* ITS_TECHNOLOGY: #47, #50, #537
* ITS_PRIORITY: #47, #51, #52, #31, #32 ['required']
* ITS_ID: #47 ['WS 1 TP 2']
* BASICCURVE: #47, #53, #54, #55, #56
*/
#47=MACHINING_TOOLPATH('WS 1 TP 2','cutter location trajectory','','');
#48=ACTION_PROPERTY('trajectory type','cutter location trajectory',#47);
#49=ACTION_PROPERTY_REPRESENTATION('','cutter location trajectory',#48,#26);
#50=MACHINING_TECHNOLOGY_RELATIONSHIP('','cutter location trajectory',#47,
#537);
#51=ACTION_PROPERTY('priority','cutter location trajectory',#47);
#52=ACTION_PROPERTY_REPRESENTATION('','cutter location trajectory',#51,#31);
#53=ACTION_PROPERTY('basic curve','cutter location trajectory',#47);
#54=ACTION_PROPERTY_REPRESENTATION('','cutter location trajectory',#53,#55);
#55=REPRESENTATION('',(#56),#42);
#56=COMPOSITE_CURVE('composite curve for WS 1 TP 2',(#57,#61,#69),.F.);
#57=COMPOSITE_CURVE_SEGMENT(.CONTINUOUS.,.T.,#58);
#58=POLYLINE('basic curve for WS 1 TP 2',(#46,#59,#60));
#59=CARTESIAN_POINT('',(76.6078,112.6997,20.));
#60=CARTESIAN_POINT('',(93.5102,109.6997,20.));
#61=COMPOSITE_CURVE_SEGMENT(.CONTINUOUS.,.T.,#62);
#62=TRIMMED_CURVE('Arc for in WS 1 TP 2',#63,(#60),(#68),.F.,.CARTESIAN.);
#63=CIRCLE('Circle for in WS 1 TP 2',#64,19.8938);

```

```

#64=AXIS2_PLACEMENT_3D('Arc placement for in WS 1 TP 2',#65,#66,#67);
#65=CARTESIAN_POINT('Arc centre for in WS 1 TP 2',(90.0336,90.112,20.));
#66=DIRECTION('Z direction',(0.,0.,1.));
#67=DIRECTION('X direction',(1.,0.,0.));
#68=CARTESIAN_POINT('Arc end for in WS 1 TP 2',(102.0069,105.9992,20.));
#69=COMPOSITE_CURVE_SEGMENT(.DISCONTINUOUS.,.T.,#70);
#70=TRIMMED_CURVE('Arc for in WS 1 TP 2',#71,(#68),(#74),.F.,.CARTESIAN.);
#71=CIRCLE('Circle for in WS 1 TP 2',#72,20.0085);
#72=AXIS2_PLACEMENT_3D('Arc placement for in WS 1 TP 2',#73,#66,#67);
#73=CARTESIAN_POINT('Arc centre for in WS 1 TP 2',(89.9986,89.9948,20.));
#74=CARTESIAN_POINT('Arc end for in WS 1 TP 2',(109.6997,93.4889,20.));

/*****
* Application object: CUTTER_LOCATION_TRAJECTORY (#75)
* ITS_TYPE: #75, #76, #77, #26, #27 ['trajectory path']
* ITS_TECHNOLOGY: #75, #78, #537
* ITS_PRIORITY: #75, #79, #80, #31, #32 ['required']
* RAPID_SPEED: #75, #81, #82, #83, #84 ['true']
* ITS_ID: #75 ['WS 1 TP 3']
* BASICCURVE: #75, #85, #86, #87, #88
*/
#75=MACHINING_TOOLPATH('WS 1 TP 3','cutter location trajectory','',');
#76=ACTION_PROPERTY('trajectory type','cutter location trajectory',#75);
#77=ACTION_PROPERTY_REPRESENTATION('','cutter location trajectory',#76,#26);
#78=MACHINING_TECHNOLOGY_RELATIONSHIP('','cutter location trajectory',#75,
#537);
#79=ACTION_PROPERTY('priority','cutter location trajectory',#75);
#80=ACTION_PROPERTY_REPRESENTATION('','cutter location trajectory',#79,#31);
#81=ACTION_PROPERTY('speed profile','rapid',#75);
#82=ACTION_PROPERTY_REPRESENTATION('','rapid',#81,#83);
#83=MACHINING_TOOLPATH_SPEED_PROFILE_REPRESENTATION('',(84),#41);
#84=DESCRIPTIVE_REPRESENTATION_ITEM('','rapid');
#85=ACTION_PROPERTY('basic curve','cutter location trajectory',#75);
#86=ACTION_PROPERTY_REPRESENTATION('','cutter location trajectory',#85,#87);
#87=REPRESENTATION('',(88),#42);
#88=POLYLINE('basic curve for WS 1 TP 3',(74,#89,#90,#91,#92,#93));
#89=CARTESIAN_POINT('',(112.6997,76.5738,20.));
#90=CARTESIAN_POINT('',(112.6997,76.5738,23.));
#91=CARTESIAN_POINT('',(112.6997,76.5738,28.));
#92=CARTESIAN_POINT('',(-12.6979,98.9837,28.));
#93=CARTESIAN_POINT('',(-12.6979,98.9837,23.));

/*****
* Application object: CUTTER_LOCATION_TRAJECTORY (#94)
* ITS_TYPE: #94, #95, #96, #26, #27 ['trajectory path']
* ITS_TECHNOLOGY: #94, #97, #537
* ITS_PRIORITY: #94, #98, #99, #31, #32 ['required']
* ITS_ID: #94 ['WS 1 TP 4']
* BASICCURVE: #94, #100, #101, #102, #103
*/
#94=MACHINING_TOOLPATH('WS 1 TP 4','cutter location trajectory','',');
#95=ACTION_PROPERTY('trajectory type','cutter location trajectory',#94);
#96=ACTION_PROPERTY_REPRESENTATION('','cutter location trajectory',#95,#26);
#97=MACHINING_TECHNOLOGY_RELATIONSHIP('','cutter location trajectory',#94,

```

```

#537);
#98=ACTION_PROPERTY('priority','cutter location trajectory',#94);
#99=ACTION_PROPERTY_REPRESENTATION('','cutter location trajectory',#98,#31);
#100=ACTION_PROPERTY('basic curve','cutter location trajectory',#94);
#101=ACTION_PROPERTY_REPRESENTATION('','cutter location trajectory',#100,
#102);
#102=REPRESENTATION('',( #103),#42);
#103=COMPOSITE_CURVE('composite curve for WS 1 TP 4',( #104,#108,#114,#120,
#126,#132,#137,#143),.F.);
#104=COMPOSITE_CURVE_SEGMENT(.CONTINUOUS.,.T.,#105);
#105=POLYLINE('basic curve for WS 1 TP 4',( #93,#106,#107));
#106=CARTESIAN_POINT('',(-12.6979,98.9837,20.));
#107=CARTESIAN_POINT('',(-9.5374,101.5877,20.));
#108=COMPOSITE_CURVE_SEGMENT(.CONTINUOUS.,.T.,#109);
#109=TRIMMED_CURVE('Arc for in WS 1 TP 4',#110,(#107),(#113),.F.,.CARTESIAN.);
#110=CIRCLE('Circle for in WS 1 TP 4',#111,14.9775);
#111=AXIS2_PLACEMENT_3D('Arc placement for in WS 1 TP 4',#112,#66,#67);
#112=CARTESIAN_POINT('Arc centre for in WS 1 TP 4',(-0.0136,90.028,20.));
#113=CARTESIAN_POINT('Arc end for in WS 1 TP 4',(-1.9146,104.8844,20.));
#114=COMPOSITE_CURVE_SEGMENT(.CONTINUOUS.,.T.,#115);
#115=POLYLINE('basic curve for WS 1 TP 4',( #113,#116,#117,#118,#119));
#116=CARTESIAN_POINT('',(-1.7697,104.9029,20.));
#117=CARTESIAN_POINT('',(-0.3611,105.0001,20.));
#118=CARTESIAN_POINT('',(90.4542,105.0001,20.));
#119=CARTESIAN_POINT('',(90.539,104.9972,20.));
#120=COMPOSITE_CURVE_SEGMENT(.CONTINUOUS.,.T.,#121);
#121=TRIMMED_CURVE('Arc for in WS 1 TP 4',#122,(#119),(#125),.F.,.CARTESIAN.);
#122=CIRCLE('Circle for in WS 1 TP 4',#123,14.8938);
#123=AXIS2_PLACEMENT_3D('Arc placement for in WS 1 TP 4',#124,#66,#67);
#124=CARTESIAN_POINT('Arc centre for in WS 1 TP 4',(90.0336,90.112,20.));
#125=CARTESIAN_POINT('Arc end for in WS 1 TP 4',(99.0019,102.003,20.));
#126=COMPOSITE_CURVE_SEGMENT(.CONTINUOUS.,.T.,#127);
#127=TRIMMED_CURVE('Arc for in WS 1 TP 4',#128,(#125),(#131),.F.,.CARTESIAN.);
#128=CIRCLE('Circle for in WS 1 TP 4',#129,15.0085);
#129=AXIS2_PLACEMENT_3D('Arc placement for in WS 1 TP 4',#130,#66,#67);
#130=CARTESIAN_POINT('Arc centre for in WS 1 TP 4',(89.9986,89.9948,20.));
#131=CARTESIAN_POINT('Arc end for in WS 1 TP 4',(104.9966,90.5564,20.));
#132=COMPOSITE_CURVE_SEGMENT(.CONTINUOUS.,.T.,#133);
#133=POLYLINE('basic curve for WS 1 TP 4',( #131,#134,#135,#136));
#134=CARTESIAN_POINT('',(105.0001,90.4629,20.));
#135=CARTESIAN_POINT('',(105.0001,-0.2221,20.));
#136=CARTESIAN_POINT('',(104.9997,-0.2552,20.));
#137=COMPOSITE_CURVE_SEGMENT(.CONTINUOUS.,.T.,#138);
#138=TRIMMED_CURVE('Arc for in WS 1 TP 4',#139,(#136),(#142),.F.,.CARTESIAN.);
#139=CIRCLE('Circle for in WS 1 TP 4',#140,14.8411);
#140=AXIS2_PLACEMENT_3D('Arc placement for in WS 1 TP 4',#141,#66,#67);
#141=CARTESIAN_POINT('Arc centre for in WS 1 TP 4',(90.1599,-0.0584,20.));
#142=CARTESIAN_POINT('Arc end for in WS 1 TP 4',(102.0037,-9.0016,20.));
#143=COMPOSITE_CURVE_SEGMENT(.DISCONTINUOUS.,.T.,#144);
#144=TRIMMED_CURVE('Arc for in WS 1 TP 4',#145,(#142),(#148),.F.,.CARTESIAN.);
#145=CIRCLE('Circle for in WS 1 TP 4',#146,14.9146);
#146=AXIS2_PLACEMENT_3D('Arc placement for in WS 1 TP 4',#147,#66,#67);
#147=CARTESIAN_POINT('Arc centre for in WS 1 TP 4',(90.0613,-0.0673,20.));
#148=CARTESIAN_POINT('Arc end for in WS 1 TP 4',(101.5829,-9.5381,20.));

```

```

/*****
* Application object: CUTTER_LOCATION_TRAJECTORY (#149)
* ITS_TYPE: #149, #150, #151, #26, #27 ['trajectory path']
* ITS_TECHNOLOGY: #149, #152, #537
* ITS_PRIORITY: #149, #153, #154, #31, #32 ['required']
* RAPID_SPEED: #149, #155, #156, #157, #158 ['true']
* ITS_ID: #149 ['WS 1 TP 5']
* BASICCURVE: #149, #159, #160, #161, #162
*/
#149=MACHINING_TOOLPATH('WS 1 TP 5','cutter location trajectory','','');
#150=ACTION_PROPERTY('trajectory type','cutter location trajectory',#149);
#151=ACTION_PROPERTY_REPRESENTATION('','cutter location trajectory',#150,
#26);
#152=MACHINING_TECHNOLOGY_RELATIONSHIP('','cutter location trajectory',#149,
#537);
#153=ACTION_PROPERTY('priority','cutter location trajectory',#149);
#154=ACTION_PROPERTY_REPRESENTATION('','cutter location trajectory',#153,
#31);
#155=ACTION_PROPERTY('speed profile','rapid',#149);
#156=ACTION_PROPERTY_REPRESENTATION('','rapid',#155,#157);
#157=MACHINING_TOOLPATH_SPEED_PROFILE_REPRESENTATION('',( #158 ),#41);
#158=DESCRIPTIVE_REPRESENTATION_ITEM('','rapid');
#159=ACTION_PROPERTY('basic curve','cutter location trajectory',#149);
#160=ACTION_PROPERTY_REPRESENTATION('','cutter location trajectory',#159,
#161);
#161=REPRESENTATION('',( #162 ),#42);
#162=POLYLINE('basic curve for WS 1 TP 5',( #148 ,#163 ,#164 ,#165 ,#166 ,#167 ));
#163=CARTESIAN_POINT('',(98.9855,-12.6979,20.));
#164=CARTESIAN_POINT('',(98.9855,-12.6979,23.));
#165=CARTESIAN_POINT('',(98.9855,-12.6979,28.));
#166=CARTESIAN_POINT('',(-12.9971,88.1,28.));
#167=CARTESIAN_POINT('',(-12.9971,88.1,23.));

/*****
* Application object: CUTTER_LOCATION_TRAJECTORY (#168)
* ITS_TYPE: #168, #169, #170, #26, #27 ['trajectory path']
* ITS_TECHNOLOGY: #168, #171, #537
* ITS_PRIORITY: #168, #172, #173, #31, #32 ['required']
* ITS_ID: #168 ['WS 1 TP 6']
* BASICCURVE: #168, #174, #175, #176, #177
*/
#168=MACHINING_TOOLPATH('WS 1 TP 6','cutter location trajectory','','');
#169=ACTION_PROPERTY('trajectory type','cutter location trajectory',#168);
#170=ACTION_PROPERTY_REPRESENTATION('','cutter location trajectory',#169,
#26);
#171=MACHINING_TECHNOLOGY_RELATIONSHIP('','cutter location trajectory',#168,
#537);
#172=ACTION_PROPERTY('priority','cutter location trajectory',#168);
#173=ACTION_PROPERTY_REPRESENTATION('','cutter location trajectory',#172,
#31);
#174=ACTION_PROPERTY('basic curve','cutter location trajectory',#168);
#175=ACTION_PROPERTY_REPRESENTATION('','cutter location trajectory',#174,
#176);

```

```

#176=REPRESENTATION('', (#177), #42);
#177=COMPOSITE_CURVE('composite curve for WS 1 TP 6', (#178, #181, #187, #193,
#199, #203, #209, #215, #218, #224, #230, #236), .F.);
#178=COMPOSITE_CURVE_SEGMENT(.CONTINUOUS., .T., #179);
#179=POLYLINE('basic curve for WS 1 TP 6', (#167, #180));
#180=CARTESIAN_POINT('', (-12.9971, 88.1, 20.));
#181=COMPOSITE_CURVE_SEGMENT(.CONTINUOUS., .T., #182);
#182=TRIMMED_CURVE('Arc for in WS 1 TP 6', #183, (#180), (#186), .T., .CARTESIAN.);
#183=CIRCLE('Circle for in WS 1 TP 6', #184, 7.);
#184=AXIS2_PLACEMENT_3D('Arc placement for in WS 1 TP 6', #185, #66, #67);
#185=CARTESIAN_POINT('Arc centre for in WS 1 TP 6', (-16.4813, 94.1712, 20.));
#186=CARTESIAN_POINT('Arc end for in WS 1 TP 6', (-9.6979, 92.4432, 20.));
#187=COMPOSITE_CURVE_SEGMENT(.CONTINUOUS., .T., #188);
#188=TRIMMED_CURVE('Arc for in WS 1 TP 6', #189, (#186), (#192), .F., .CARTESIAN.);
#189=CIRCLE('Circle for in WS 1 TP 6', #190, 10.2831);
#190=AXIS2_PLACEMENT_3D('Arc placement for in WS 1 TP 6', #191, #66, #67);
#191=CARTESIAN_POINT('Arc centre for in WS 1 TP 6', (0.2669, 89.9048, 20.));
#192=CARTESIAN_POINT('Arc end for in WS 1 TP 6', (-8.8119, 94.7336, 20.));
#193=COMPOSITE_CURVE_SEGMENT(.CONTINUOUS., .T., #194);
#194=TRIMMED_CURVE('Arc for in WS 1 TP 6', #195, (#192), (#198), .F., .CARTESIAN.);
#195=CIRCLE('Circle for in WS 1 TP 6', #196, 9.9775);
#196=AXIS2_PLACEMENT_3D('Arc placement for in WS 1 TP 6', #197, #66, #67);
#197=CARTESIAN_POINT('Arc centre for in WS 1 TP 6', (-0.0136, 90.028, 20.));
#198=CARTESIAN_POINT('Arc end for in WS 1 TP 6', (-1.28, 99.9248, 20.));
#199=COMPOSITE_CURVE_SEGMENT(.CONTINUOUS., .T., #200);
#200=POLYLINE('basic curve for WS 1 TP 6', (#198, #201, #202));
#201=CARTESIAN_POINT('', (-0.1889, 100.0001, 20.));
#202=CARTESIAN_POINT('', (90.3693, 100.0001, 20.));
#203=COMPOSITE_CURVE_SEGMENT(.CONTINUOUS., .T., #204);
#204=TRIMMED_CURVE('Arc for in WS 1 TP 6', #205, (#202), (#208), .F., .CARTESIAN.);
#205=CIRCLE('Circle for in WS 1 TP 6', #206, 9.8938);
#206=AXIS2_PLACEMENT_3D('Arc placement for in WS 1 TP 6', #207, #66, #67);
#207=CARTESIAN_POINT('Arc centre for in WS 1 TP 6', (90.0336, 90.112, 20.));
#208=CARTESIAN_POINT('Arc end for in WS 1 TP 6', (95.9968, 98.0068, 20.));
#209=COMPOSITE_CURVE_SEGMENT(.CONTINUOUS., .T., #210);
#210=TRIMMED_CURVE('Arc for in WS 1 TP 6', #211, (#208), (#214), .F., .CARTESIAN.);
#211=CIRCLE('Circle for in WS 1 TP 6', #212, 10.0085);
#212=AXIS2_PLACEMENT_3D('Arc placement for in WS 1 TP 6', #213, #66, #67);
#213=CARTESIAN_POINT('Arc centre for in WS 1 TP 6', (89.9986, 89.9948, 20.));
#214=CARTESIAN_POINT('Arc end for in WS 1 TP 6', (100.0001, 90.3693, 20.));
#215=COMPOSITE_CURVE_SEGMENT(.CONTINUOUS., .T., #216);
#216=POLYLINE('basic curve for WS 1 TP 6', (#214, #217));
#217=CARTESIAN_POINT('', (100.0001, -0.1889, 20.));
#218=COMPOSITE_CURVE_SEGMENT(.CONTINUOUS., .T., #219);
#219=TRIMMED_CURVE('Arc for in WS 1 TP 6', #220, (#217), (#223), .F., .CARTESIAN.);
#220=CIRCLE('Circle for in WS 1 TP 6', #221, 9.8411);
#221=AXIS2_PLACEMENT_3D('Arc placement for in WS 1 TP 6', #222, #66, #67);
#222=CARTESIAN_POINT('Arc centre for in WS 1 TP 6', (90.1599, -0.0584, 20.));
#223=CARTESIAN_POINT('Arc end for in WS 1 TP 6', (98.0068, -5.9975, 20.));
#224=COMPOSITE_CURVE_SEGMENT(.CONTINUOUS., .T., #225);
#225=TRIMMED_CURVE('Arc for in WS 1 TP 6', #226, (#223), (#229), .F., .CARTESIAN.);
#226=CIRCLE('Circle for in WS 1 TP 6', #227, 9.9146);
#227=AXIS2_PLACEMENT_3D('Arc placement for in WS 1 TP 6', #228, #66, #67);
#228=CARTESIAN_POINT('Arc centre for in WS 1 TP 6', (90.0613, -0.0673, 20.));

```

```

#229=CARTESIAN_POINT('Arc end for in WS 1 TP 6', (94.7336, -8.8119, 20.));
#230=COMPOSITE_CURVE_SEGMENT(.CONTINUOUS., .T., #231);
#231=TRIMMED_CURVE('Arc for in WS 1 TP 6', #232, (#229), (#235), .F., .CARTESIAN.);
#232=CIRCLE('Circle for in WS 1 TP 6', #233, 9.6195);
#233=AXIS2_PLACEMENT_3D('Arc placement for in WS 1 TP 6', #234, #66, #67);
#234=CARTESIAN_POINT('Arc centre for in WS 1 TP 6', (90.1227, -0.3694, 20.));
#235=CARTESIAN_POINT('Arc end for in WS 1 TP 6', (92.4709, -9.6979, 20.));
#236=COMPOSITE_CURVE_SEGMENT(.DISCONTINUOUS., .T., #237);
#237=TRIMMED_CURVE('Arc for in WS 1 TP 6', #238, (#235), (#241), .T., .CARTESIAN.);
#238=CIRCLE('Circle for in WS 1 TP 6', #239, 7.);
#239=AXIS2_PLACEMENT_3D('Arc placement for in WS 1 TP 6', #240, #66, #67);
#240=CARTESIAN_POINT('Arc centre for in WS 1 TP 6', (94.1797, -16.4862, 20.));
#241=CARTESIAN_POINT('Arc end for in WS 1 TP 6', (87.6325, -14.0095, 20.));

```

```

/*****
* Application object: CUTTER_LOCATION_TRAJECTORY (#242)
* ITS_TYPE: #242, #243, #244, #26, #27 ['trajectory path']
* ITS_TECHNOLOGY: #242, #245, #537
* ITS_PRIORITY: #242, #246, #247, #31, #32 ['required']
* RAPID_SPEED: #242, #248, #249, #250, #251 ['true']
* ITS_ID: #242 ['WS 1 TP 7']
* BASICCURVE: #242, #252, #253, #254, #255
*/
#242=MACHINING_TOOLPATH('WS 1 TP 7', 'cutter location trajectory', '', '');
#243=ACTION_PROPERTY('trajectory type', 'cutter location trajectory', #242);
#244=ACTION_PROPERTY_REPRESENTATION('', 'cutter location trajectory', #243,
#26);
#245=MACHINING_TECHNOLOGY_RELATIONSHIP('', 'cutter location trajectory', #242,
#537);
#246=ACTION_PROPERTY('priority', 'cutter location trajectory', #242);
#247=ACTION_PROPERTY_REPRESENTATION('', 'cutter location trajectory', #246,
#31);
#248=ACTION_PROPERTY('speed profile', 'rapid', #242);
#249=ACTION_PROPERTY_REPRESENTATION('', 'rapid', #248, #250);
#250=MACHINING_TOOLPATH_SPEED_PROFILE_REPRESENTATION('', (#251), #41);
#251=DESCRIPTIVE_REPRESENTATION_ITEM('', 'rapid');
#252=ACTION_PROPERTY('basic curve', 'cutter location trajectory', #242);
#253=ACTION_PROPERTY_REPRESENTATION('', 'cutter location trajectory', #252,
#254);
#254=REPRESENTATION('', (#255), #42);
#255=POLYLINE('basic curve for WS 1 TP 7', (#241, #256, #257, #258, #259, #260));
#256=CARTESIAN_POINT('', (87.6325, -14.0095, 23.));
#257=CARTESIAN_POINT('', (87.6325, -14.0095, 31.));
#258=CARTESIAN_POINT('', (76.7996, 112.6997, 31.));
#259=CARTESIAN_POINT('', (76.7996, 112.6997, 23.));
#260=CARTESIAN_POINT('', (76.7996, 112.6997, 18.));

```

```

/*****
* Application object: CUTTER_LOCATION_TRAJECTORY (#261)
* ITS_TYPE: #261, #262, #263, #26, #27 ['trajectory path']
* ITS_TECHNOLOGY: #261, #264, #537
* ITS_PRIORITY: #261, #265, #266, #31, #32 ['required']
* ITS_ID: #261 ['WS 1 TP 8']
* BASICCURVE: #261, #267, #268, #269, #270

```

```

*/
#261=MACHINING_TOOLPATH('WS 1 TP 8','cutter location trajectory','','');
#262=ACTION_PROPERTY('trajectory type','cutter location trajectory',#261);
#263=ACTION_PROPERTY_REPRESENTATION('','cutter location trajectory',#262,
#26);
#264=MACHINING_TECHNOLOGY_RELATIONSHIP('','cutter location trajectory',#261,
#537);
#265=ACTION_PROPERTY('priority','cutter location trajectory',#261);
#266=ACTION_PROPERTY_REPRESENTATION('','cutter location trajectory',#265,
#31);
#267=ACTION_PROPERTY('basic curve','cutter location trajectory',#261);
#268=ACTION_PROPERTY_REPRESENTATION('','cutter location trajectory',#267,
#269);
#269=REPRESENTATION('',( #270), #42);
#270=COMPOSITE_CURVE('composite curve for WS 1 TP 8', (#271, #275, #281, #285,
#291, #295), .F.);
#271=COMPOSITE_CURVE_SEGMENT(.CONTINUOUS., .T., #272);
#272=POLYLINE('basic curve for WS 1 TP 8', (#260, #273, #274));
#273=CARTESIAN_POINT('',(76.7996,112.6997,15.));
#274=CARTESIAN_POINT('',(93.5151,109.6997,15.));
#275=COMPOSITE_CURVE_SEGMENT(.CONTINUOUS., .T., #276);
#276=TRIMMED_CURVE('Arc for in WS 1 TP 8', #277, (#274), (#280), .F., .CARTESIAN.);
#277=CIRCLE('Circle for in WS 1 TP 8', #278, 20.0969);
#278=AXIS2_PLACEMENT_3D('Arc placement for in WS 1 TP 8', #279, #66, #67);
#279=CARTESIAN_POINT('Arc centre for in WS 1 TP 8', (89.9649, 89.9188, 15.));
#280=CARTESIAN_POINT('Arc end for in WS 1 TP 8', (101.6281, 106.2851, 15.));
#281=COMPOSITE_CURVE_SEGMENT(.CONTINUOUS., .T., #282);
#282=POLYLINE('basic curve for WS 1 TP 8', (#280, #283, #284));
#283=CARTESIAN_POINT('',(101.6318,106.2824,15.));
#284=CARTESIAN_POINT('',(101.6356,106.2798,15.));
#285=COMPOSITE_CURVE_SEGMENT(.CONTINUOUS., .T., #286);
#286=TRIMMED_CURVE('Arc for in WS 1 TP 8', #287, (#284), (#290), .F., .CARTESIAN.);
#287=CIRCLE('Circle for in WS 1 TP 8', #288, 19.9541);
#288=AXIS2_PLACEMENT_3D('Arc placement for in WS 1 TP 8', #289, #66, #67);
#289=CARTESIAN_POINT('Arc centre for in WS 1 TP 8', (90.0404, 90.0404, 15.));
#290=CARTESIAN_POINT('Arc end for in WS 1 TP 8', (107.6374, 99.4484, 15.));
#291=COMPOSITE_CURVE_SEGMENT(.CONTINUOUS., .T., #292);
#292=POLYLINE('basic curve for WS 1 TP 8', (#290, #293, #294));
#293=CARTESIAN_POINT('',(107.6398,99.4439,15.));
#294=CARTESIAN_POINT('',(107.6422,99.4394,15.));
#295=COMPOSITE_CURVE_SEGMENT(.DISCONTINUOUS., .T., #296);
#296=TRIMMED_CURVE('Arc for in WS 1 TP 8', #297, (#294), (#300), .F., .CARTESIAN.);
#297=CIRCLE('Circle for in WS 1 TP 8', #298, 20.1824);
#298=AXIS2_PLACEMENT_3D('Arc placement for in WS 1 TP 8', #299, #66, #67);
#299=CARTESIAN_POINT('Arc centre for in WS 1 TP 8', (89.8342, 89.9419, 15.));
#300=CARTESIAN_POINT('Arc end for in WS 1 TP 8', (109.6997, 93.5045, 15.));

/*****
* Application object: CUTTER_LOCATION_TRAJECTORY (#301)
* ITS_TYPE: #301, #302, #303, #26, #27 ['trajectory path']
* ITS_TECHNOLOGY: #301, #304, #537
* ITS_PRIORITY: #301, #305, #306, #31, #32 ['required']
* RAPID_SPEED: #301, #307, #308, #309, #310 ['true']
* ITS_ID: #301 ['WS 1 TP 9']

```



```

* BASICCURVE: #301, #311, #312, #313, #314
*/
#301=MACHINING_TOOLPATH('WS 1 TP 9','cutter location trajectory','','');
#302=ACTION_PROPERTY('trajectory type','cutter location trajectory',#301);
#303=ACTION_PROPERTY_REPRESENTATION('','cutter location trajectory',#302,
#26);
#304=MACHINING_TECHNOLOGY_RELATIONSHIP('','cutter location trajectory',#301,
#537);
#305=ACTION_PROPERTY('priority','cutter location trajectory',#301);
#306=ACTION_PROPERTY_REPRESENTATION('','cutter location trajectory',#305,
#31);
#307=ACTION_PROPERTY('speed profile','rapid',#301);
#308=ACTION_PROPERTY_REPRESENTATION('','rapid',#307,#309);
#309=MACHINING_TOOLPATH_SPEED_PROFILE_REPRESENTATION('',( #310),#41);
#310=DESCRIPTIVE_REPRESENTATION_ITEM('','rapid');
#311=ACTION_PROPERTY('basic curve','cutter location trajectory',#301);
#312=ACTION_PROPERTY_REPRESENTATION('','cutter location trajectory',#311,
#313);
#313=REPRESENTATION('',( #314),#42);
#314=POLYLINE('basic curve for WS 1 TP 9',( #300,#315,#316,#317,#318,#319,
#320));
#315=CARTESIAN_POINT('',(112.6997,76.7764,15.));
#316=CARTESIAN_POINT('',(112.6997,76.7764,18.));
#317=CARTESIAN_POINT('',(112.6997,76.7764,31.));
#318=CARTESIAN_POINT('',(-12.6979,98.9932,31.));
#319=CARTESIAN_POINT('',(-12.6979,98.9932,23.));
#320=CARTESIAN_POINT('',(-12.6979,98.9932,18.));

/*****
* Application object: CUTTER_LOCATION_TRAJECTORY (#321)
* ITS_TYPE: #321, #322, #323, #26, #27 ['trajectory path']
* ITS_TECHNOLOGY: #321, #324, #537
* ITS_PRIORITY: #321, #325, #326, #31, #32 ['required']
* ITS_ID: #321 ['WS 1 TP 10']
* BASICCURVE: #321, #327, #328, #329, #330
*/
#321=MACHINING_TOOLPATH('WS 1 TP 10','cutter location trajectory','','');
#322=ACTION_PROPERTY('trajectory type','cutter location trajectory',#321);
#323=ACTION_PROPERTY_REPRESENTATION('','cutter location trajectory',#322,
#26);
#324=MACHINING_TECHNOLOGY_RELATIONSHIP('','cutter location trajectory',#321,
#537);
#325=ACTION_PROPERTY('priority','cutter location trajectory',#321);
#326=ACTION_PROPERTY_REPRESENTATION('','cutter location trajectory',#325,
#31);
#327=ACTION_PROPERTY('basic curve','cutter location trajectory',#321);
#328=ACTION_PROPERTY_REPRESENTATION('','cutter location trajectory',#327,
#329);
#329=REPRESENTATION('',( #330),#42);
#330=COMPOSITE_CURVE('composite curve for WS 1 TP 10',( #331,#335,#341,#347,
#353,#357,#363,#367,#373,#378,#384),.F.);
#331=COMPOSITE_CURVE_SEGMENT(.CONTINUOUS.,.T.,#332);
#332=POLYLINE('basic curve for WS 1 TP 10',( #320,#333,#334));
#333=CARTESIAN_POINT('',(-12.6979,98.9932,15.));

```

```

#334=CARTESIAN_POINT('', (-9.5364,101.5958,15.));
#335=COMPOSITE_CURVE_SEGMENT(.CONTINUOUS.,.T.,#336);
#336=TRIMMED_CURVE('Arc for in WS 1 TP
10',#337, (#334), (#340), .F.,.CARTESIAN.);
#337=CIRCLE('Circle for in WS 1 TP 10',#338,14.9952);
#338=AXIS2_PLACEMENT_3D('Arc placement for in WS 1 TP 10',#339,#66,#67);
#339=CARTESIAN_POINT('Arc centre for in WS 1 TP 10',(-0.0061,90.0187,15.));
#340=CARTESIAN_POINT('Arc end for in WS 1 TP 10',(-1.9172,104.8916,15.));
#341=COMPOSITE_CURVE_SEGMENT(.CONTINUOUS.,.T.,#342);
#342=POLYLINE('basic curve for WS 1 TP 10',(#340,#343,#344,#345,#346));
#343=CARTESIAN_POINT('', (-1.771,104.9104,15.));
#344=CARTESIAN_POINT('', (-0.3611,105.0076,15.));
#345=CARTESIAN_POINT('', (90.4695,105.0076,15.));
#346=CARTESIAN_POINT('', (90.5696,105.0036,15.));
#347=COMPOSITE_CURVE_SEGMENT(.CONTINUOUS.,.T.,#348);
#348=TRIMMED_CURVE('Arc for in WS 1 TP
10',#349, (#346), (#352), .F.,.CARTESIAN.);
#349=CIRCLE('Circle for in WS 1 TP 10',#350,15.0969);
#350=AXIS2_PLACEMENT_3D('Arc placement for in WS 1 TP 10',#351,#66,#67);
#351=CARTESIAN_POINT('Arc centre for in WS 1 TP 10', (89.9649,89.9188,15.));
#352=CARTESIAN_POINT('Arc end for in WS 1 TP 10', (98.7264,102.2132,15.));
#353=COMPOSITE_CURVE_SEGMENT(.CONTINUOUS.,.T.,#354);
#354=POLYLINE('basic curve for WS 1 TP 10',(#352,#355,#356));
#355=CARTESIAN_POINT('', (98.7282,102.2119,15.));
#356=CARTESIAN_POINT('', (98.7301,102.2106,15.));
#357=COMPOSITE_CURVE_SEGMENT(.CONTINUOUS.,.T.,#358);
#358=TRIMMED_CURVE('Arc for in WS 1 TP
10',#359, (#356), (#362), .F.,.CARTESIAN.);
#359=CIRCLE('Circle for in WS 1 TP 10',#360,14.9541);
#360=AXIS2_PLACEMENT_3D('Arc placement for in WS 1 TP 10',#361,#66,#67);
#361=CARTESIAN_POINT('Arc centre for in WS 1 TP 10', (90.0404,90.0404,15.));
#362=CARTESIAN_POINT('Arc end for in WS 1 TP 10', (103.228,97.091,15.));
#363=COMPOSITE_CURVE_SEGMENT(.CONTINUOUS.,.T.,#364);
#364=POLYLINE('basic curve for WS 1 TP 10',(#362,#365,#366));
#365=CARTESIAN_POINT('', (103.2292,97.0888,15.));
#366=CARTESIAN_POINT('', (103.2304,97.0865,15.));
#367=COMPOSITE_CURVE_SEGMENT(.CONTINUOUS.,.T.,#368);
#368=TRIMMED_CURVE('Arc for in WS 1 TP
10',#369, (#366), (#372), .F.,.CARTESIAN.);
#369=CIRCLE('Circle for in WS 1 TP 10',#370,15.1824);
#370=AXIS2_PLACEMENT_3D('Arc placement for in WS 1 TP 10',#371,#66,#67);
#371=CARTESIAN_POINT('Arc centre for in WS 1 TP 10', (89.8342,89.9419,15.));
#372=CARTESIAN_POINT('Arc end for in WS 1 TP 10', (105.0032,90.5792,15.));
#373=COMPOSITE_CURVE_SEGMENT(.CONTINUOUS.,.T.,#374);
#374=POLYLINE('basic curve for WS 1 TP 10',(#372,#375,#376,#377));
#375=CARTESIAN_POINT('', (105.0076,90.4743,15.));
#376=CARTESIAN_POINT('', (105.0076,-0.222,15.));
#377=CARTESIAN_POINT('', (105.0072,-0.255,15.));
#378=COMPOSITE_CURVE_SEGMENT(.CONTINUOUS.,.T.,#379);
#379=TRIMMED_CURVE('Arc for in WS 1 TP
10',#380, (#377), (#383), .F.,.CARTESIAN.);
#380=CIRCLE('Circle for in WS 1 TP 10',#381,14.8322);
#381=AXIS2_PLACEMENT_3D('Arc placement for in WS 1 TP 10',#382,#66,#67);
#382=CARTESIAN_POINT('Arc centre for in WS 1 TP 10', (90.1763,-0.059,15.));

```

```

#383=CARTESIAN_POINT('Arc end for in WS 1 TP 10', (101.9997, -9.0144, 15.));
#384=COMPOSITE_CURVE_SEGMENT(.DISCONTINUOUS., .T., #385);
#385=TRIMMED_CURVE('Arc for in WS 1 TP
10', #386, (#383), (#389), .F., .CARTESIAN.);
#386=CIRCLE('Circle for in WS 1 TP 10', #387, 14.9841);
#387=AXIS2_PLACEMENT_3D('Arc placement for in WS 1 TP 10', #388, #66, #67);
#388=CARTESIAN_POINT('Arc centre for in WS 1 TP 10', (90.012, -0.0245, 15.));
#389=CARTESIAN_POINT('Arc end for in WS 1 TP 10', (101.589, -9.5375, 15.));

/*****
* Application object: CUTTER_LOCATION_TRAJECTORY (#390)
* ITS_TYPE: #390, #391, #392, #26, #27 ['trajectory path']
* ITS_TECHNOLOGY: #390, #393, #537
* ITS_PRIORITY: #390, #394, #395, #31, #32 ['required']
* RAPID_SPEED: #390, #396, #397, #398, #399 ['true']
* ITS_ID: #390 ['WS 1 TP 11']
* BASICCURVE: #390, #400, #401, #402, #403
*/
#390=MACHINING_TOOLPATH('WS 1 TP 11', 'cutter location trajectory', '', '');
#391=ACTION_PROPERTY('trajectory type', 'cutter location trajectory', #390);
#392=ACTION_PROPERTY_REPRESENTATION('', 'cutter location trajectory', #391,
#26);
#393=MACHINING_TECHNOLOGY_RELATIONSHIP('', 'cutter location trajectory', #390,
#537);
#394=ACTION_PROPERTY('priority', 'cutter location trajectory', #390);
#395=ACTION_PROPERTY_REPRESENTATION('', 'cutter location trajectory', #394,
#31);
#396=ACTION_PROPERTY('speed profile', 'rapid', #390);
#397=ACTION_PROPERTY_REPRESENTATION('', 'rapid', #396, #398);
#398=MACHINING_TOOLPATH_SPEED_PROFILE_REPRESENTATION('', (#399), #41);
#399=DESCRIPTIVE_REPRESENTATION_ITEM('', 'rapid');
#400=ACTION_PROPERTY('basic curve', 'cutter location trajectory', #390);
#401=ACTION_PROPERTY_REPRESENTATION('', 'cutter location trajectory', #400,
#402);
#402=REPRESENTATION('', (#403), #42);
#403=POLYLINE('basic curve for WS 1 TP 11', (#389, #404, #405, #406, #407, #408,
#409));
#404=CARTESIAN_POINT('', (98.992, -12.6979, 15.));
#405=CARTESIAN_POINT('', (98.992, -12.6979, 18.));
#406=CARTESIAN_POINT('', (98.992, -12.6979, 31.));
#407=CARTESIAN_POINT('', (-12.9934, 87.8423, 31.));
#408=CARTESIAN_POINT('', (-12.9934, 87.8423, 23.));
#409=CARTESIAN_POINT('', (-12.9934, 87.8423, 18.));

/*****
* Application object: CUTTER_LOCATION_TRAJECTORY (#410)
* ITS_TYPE: #410, #411, #412, #26, #27 ['trajectory path']
* ITS_TECHNOLOGY: #410, #413, #537
* ITS_PRIORITY: #410, #414, #415, #31, #32 ['required']
* ITS_ID: #410 ['WS 1 TP 12']
* BASICCURVE: #410, #416, #417, #418, #419
*/
#410=MACHINING_TOOLPATH('WS 1 TP 12', 'cutter location trajectory', '', '');
#411=ACTION_PROPERTY('trajectory type', 'cutter location trajectory', #410);

```

```

#412=ACTION_PROPERTY_REPRESENTATION('', 'cutter location trajectory', #411,
#26);
#413=MACHINING_TECHNOLOGY_RELATIONSHIP('', 'cutter location trajectory', #410,
#537);
#414=ACTION_PROPERTY('priority', 'cutter location trajectory', #410);
#415=ACTION_PROPERTY_REPRESENTATION('', 'cutter location trajectory', #414,
#31);
#416=ACTION_PROPERTY('basic curve', 'cutter location trajectory', #410);
#417=ACTION_PROPERTY_REPRESENTATION('', 'cutter location trajectory', #416,
#418);
#418=REPRESENTATION('', (#419), #42);
#419=COMPOSITE_CURVE('composite curve for WS 1 TP 12', (#420, #423, #429, #434,
#440, #444, #450, #456, #462, #465, #471, #477), .F.);
#420=COMPOSITE_CURVE_SEGMENT(.CONTINUOUS., .T., #421);
#421=POLYLINE('basic curve for WS 1 TP 12', (#409, #422));
#422=CARTESIAN_POINT('', (-12.9934, 87.8423, 15.));
#423=COMPOSITE_CURVE_SEGMENT(.CONTINUOUS., .T., #424);
#424=TRIMMED_CURVE('Arc for in WS 1 TP
12', #425, (#422), (#428), .T., .CARTESIAN.);
#425=CIRCLE('Circle for in WS 1 TP 12', #426, 7.);
#426=AXIS2_PLACEMENT_3D('Arc placement for in WS 1 TP 12', #427, #66, #67);
#427=CARTESIAN_POINT('Arc centre for in WS 1 TP 12', (-16.5527, 93.8698, 15.));
#428=CARTESIAN_POINT('Arc end for in WS 1 TP 12', (-9.6979, 92.4515, 15.));
#429=COMPOSITE_CURVE_SEGMENT(.CONTINUOUS., .T., #430);
#430=POLYLINE('basic curve for WS 1 TP 12', (#428, #431, #432, #433));
#431=CARTESIAN_POINT('', (-9.6772, 92.5514, 15.));
#432=CARTESIAN_POINT('', (-9.316, 93.6425, 15.));
#433=CARTESIAN_POINT('', (-8.8194, 94.7336, 15.));
#434=COMPOSITE_CURVE_SEGMENT(.CONTINUOUS., .T., #435);
#435=TRIMMED_CURVE('Arc for in WS 1 TP
12', #436, (#433), (#439), .F., .CARTESIAN.);
#436=CIRCLE('Circle for in WS 1 TP 12', #437, 9.9952);
#437=AXIS2_PLACEMENT_3D('Arc placement for in WS 1 TP 12', #438, #66, #67);
#438=CARTESIAN_POINT('Arc centre for in WS 1 TP 12', (-0.0061, 90.0187, 15.));
#439=CARTESIAN_POINT('Arc end for in WS 1 TP 12', (-1.28, 99.9324, 15.));
#440=COMPOSITE_CURVE_SEGMENT(.CONTINUOUS., .T., #441);
#441=POLYLINE('basic curve for WS 1 TP 12', (#439, #442, #443));
#442=CARTESIAN_POINT('', (-0.1889, 100.0076, 15.));
#443=CARTESIAN_POINT('', (90.3693, 100.0076, 15.));
#444=COMPOSITE_CURVE_SEGMENT(.CONTINUOUS., .T., #445);
#445=TRIMMED_CURVE('Arc for in WS 1 TP
12', #446, (#443), (#449), .F., .CARTESIAN.);
#446=CIRCLE('Circle for in WS 1 TP 12', #447, 10.0969);
#447=AXIS2_PLACEMENT_3D('Arc placement for in WS 1 TP 12', #448, #66, #67);
#448=CARTESIAN_POINT('Arc centre for in WS 1 TP 12', (89.9649, 89.9188, 15.));
#449=CARTESIAN_POINT('Arc end for in WS 1 TP 12', (95.8246, 98.1414, 15.));
#450=COMPOSITE_CURVE_SEGMENT(.CONTINUOUS., .T., #451);
#451=TRIMMED_CURVE('Arc for in WS 1 TP
12', #452, (#449), (#455), .F., .CARTESIAN.);
#452=CIRCLE('Circle for in WS 1 TP 12', #453, 9.9541);
#453=AXIS2_PLACEMENT_3D('Arc placement for in WS 1 TP 12', #454, #66, #67);
#454=CARTESIAN_POINT('Arc centre for in WS 1 TP 12', (90.0404, 90.0404, 15.));
#455=CARTESIAN_POINT('Arc end for in WS 1 TP 12', (98.8187, 94.7336, 15.));
#456=COMPOSITE_CURVE_SEGMENT(.CONTINUOUS., .T., #457);

```

```

#457=TRIMMED_CURVE('Arc for in WS 1 TP
12', #458, (#455), (#461), .F., .CARTESIAN.);
#458=CIRCLE('Circle for in WS 1 TP 12', #459, 10.1824);
#459=AXIS2_PLACEMENT_3D('Arc placement for in WS 1 TP 12', #460, #66, #67);
#460=CARTESIAN_POINT('Arc centre for in WS 1 TP 12', (89.8342, 89.9419, 15.));
#461=CARTESIAN_POINT('Arc end for in WS 1 TP 12', (100.0076, 90.3693, 15.));
#462=COMPOSITE_CURVE_SEGMENT(.CONTINUOUS., .T., #463);
#463=POLYLINE('basic curve for WS 1 TP 12', (#461, #464));
#464=CARTESIAN_POINT('', (100.0076, -0.1889, 15.));
#465=COMPOSITE_CURVE_SEGMENT(.CONTINUOUS., .T., #466);
#466=TRIMMED_CURVE('Arc for in WS 1 TP
12', #467, (#464), (#470), .F., .CARTESIAN.);
#467=CIRCLE('Circle for in WS 1 TP 12', #468, 9.8322);
#468=AXIS2_PLACEMENT_3D('Arc placement for in WS 1 TP 12', #469, #66, #67);
#469=CARTESIAN_POINT('Arc centre for in WS 1 TP 12', (90.1763, -0.059, 15.));
#470=CARTESIAN_POINT('Arc end for in WS 1 TP 12', (98.0068, -6.005, 15.));
#471=COMPOSITE_CURVE_SEGMENT(.CONTINUOUS., .T., #472);
#472=TRIMMED_CURVE('Arc for in WS 1 TP
12', #473, (#470), (#476), .F., .CARTESIAN.);
#473=CIRCLE('Circle for in WS 1 TP 12', #474, 9.9841);
#474=AXIS2_PLACEMENT_3D('Arc placement for in WS 1 TP 12', #475, #66, #67);
#475=CARTESIAN_POINT('Arc centre for in WS 1 TP 12', (90.012, -0.0245, 15.));
#476=CARTESIAN_POINT('Arc end for in WS 1 TP 12', (92.4833, -9.6979, 15.));
#477=COMPOSITE_CURVE_SEGMENT(.DISCONTINUOUS., .T., #478);
#478=TRIMMED_CURVE('Arc for in WS 1 TP
12', #479, (#476), (#482), .T., .CARTESIAN.);
#479=CIRCLE('Circle for in WS 1 TP 12', #480, 7.);
#480=AXIS2_PLACEMENT_3D('Arc placement for in WS 1 TP 12', #481, #66, #67);
#481=CARTESIAN_POINT('Arc centre for in WS 1 TP 12', (94.216, -16.4801, 15.));
#482=CARTESIAN_POINT('Arc end for in WS 1 TP 12', (87.6601, -14.0265, 15.));

/*****
* Application object: DERIVED_UNIT (#483)
* NAME: #483, #484 ['revolution/minute']
*/
#483=DERIVED_UNIT((#485));
#484=NAME_ATTRIBUTE('revolution/minute', #483);
#485=DERIVED_UNIT_ELEMENT(#547, -1.);

/*****
* Application object: DERIVED_UNIT (#486)
* NAME: #486, #487 ['millimetre/minute']
*/
#486=DERIVED_UNIT((#488, #489));
#487=NAME_ATTRIBUTE('millimetre/minute', #486);
#488=DERIVED_UNIT_ELEMENT(#554, 1.);
#489=DERIVED_UNIT_ELEMENT(#547, -1.);

/*****
* Application object: FREEFORM_OPERATION (#490)
* ITS_TOOLPATH [1]: #490, #491, #23
* ITS_TOOLPATH [2]: #490, #492, #47
* ITS_TOOLPATH [3]: #490, #493, #75
* ITS_TOOLPATH [4]: #490, #494, #94

```

```

* ITS_TOOLPATH [5]: #490, #495, #149
* ITS_TOOLPATH [6]: #490, #496, #168
* ITS_TOOLPATH [7]: #490, #497, #242
* ITS_TOOLPATH [8]: #490, #498, #261
* ITS_TOOLPATH [9]: #490, #499, #301
* ITS_TOOLPATH [10]: #490, #500, #321
* ITS_TOOLPATH [11]: #490, #501, #390
* ITS_TOOLPATH [12]: #490, #502, #410
* ITS_TECHNOLOGY: #490, #503, #528
* ITS_MACHINE_FUNCTIONS: #490, #504, #515
* ITS_TOOL: #490, #580
* ITS_ID: #490 ['WS 1']
*/
#490=FREEFORM_MILLING_OPERATION('WS 1','','','');
#491=MACHINING_TOOLPATH_SEQUENCE_RELATIONSHIP('',' ',#490,#23,1.);
#492=MACHINING_TOOLPATH_SEQUENCE_RELATIONSHIP('',' ',#490,#47,2.);
#493=MACHINING_TOOLPATH_SEQUENCE_RELATIONSHIP('',' ',#490,#75,3.);
#494=MACHINING_TOOLPATH_SEQUENCE_RELATIONSHIP('',' ',#490,#94,4.);
#495=MACHINING_TOOLPATH_SEQUENCE_RELATIONSHIP('',' ',#490,#149,5.);
#496=MACHINING_TOOLPATH_SEQUENCE_RELATIONSHIP('',' ',#490,#168,6.);
#497=MACHINING_TOOLPATH_SEQUENCE_RELATIONSHIP('',' ',#490,#242,7.);
#498=MACHINING_TOOLPATH_SEQUENCE_RELATIONSHIP('',' ',#490,#261,8.);
#499=MACHINING_TOOLPATH_SEQUENCE_RELATIONSHIP('',' ',#490,#301,9.);
#500=MACHINING_TOOLPATH_SEQUENCE_RELATIONSHIP('',' ',#490,#321,10.);
#501=MACHINING_TOOLPATH_SEQUENCE_RELATIONSHIP('',' ',#490,#390,11.);
#502=MACHINING_TOOLPATH_SEQUENCE_RELATIONSHIP('',' ',#490,#410,12.);
#503=MACHINING_TECHNOLOGY_RELATIONSHIP('',' ',#490,#528);
#504=MACHINING_FUNCTIONS_RELATIONSHIP('',' ',#490,#515);

/*****
* Application object: MACHINING_WORKINGSTEP (#505)
* ITS_OPERATION: #505, #506, #490
* ITS_ID: #505 ['WS 1']
* ITS_FEATURE: #505, #507, #508, #509, #510, #567
*/
#505=MACHINING_WORKINGSTEP('WS 1','machining','','');
#506=MACHINING_OPERATION_RELATIONSHIP('','machining',#505,#490);
#507=MACHINING_FEATURE_RELATIONSHIP('','machining',#505,#508);
#508=MACHINING_FEATURE_PROCESS('','machining','','');
#509=PROPERTY_PROCESS('machining','machining',#508,'');
#510=PROCESS_PROPERTY_ASSOCIATION('','machining',#509,#567);

/*****
* Application object: MILLING_MACHINE_FUNCTIONS (#515)
* CHIP_REMOVAL: #515, #516, #517, #518, #519 ['chip removal off']
* COOLANT: #515, #520, #521, #522, #523 ['coolant off']
* THROUGH_SPINDLE_COOLANT: #515, #524, #525, #526, #527 ['through spindle
coolant off']
*/
#515=MACHINING_FUNCTIONS('','milling','','');
#516=ACTION_PROPERTY('chip removal','milling',#515);
#517=ACTION_PROPERTY_REPRESENTATION('','milling',#516,#518);
#518=REPRESENTATION('constant',(#519),#41);
#519=DESCRIPTIVE_REPRESENTATION_ITEM('constant','chip removal off');

```

```

#520=ACTION_PROPERTY('coolant','milling',#515);
#521=ACTION_PROPERTY_REPRESENTATION('','milling',#520,#522);
#522=REPRESENTATION('constant',(#523),#41);
#523=DESCRIPTIVE_REPRESENTATION_ITEM('constant','coolant off');
#524=ACTION_PROPERTY('through spindle coolant','milling',#515);
#525=ACTION_PROPERTY_REPRESENTATION('','milling',#524,#526);
#526=REPRESENTATION('constant',(#527),#41);
#527=DESCRIPTIVE_REPRESENTATION_ITEM('constant',
'through spindle coolant off');

/*****
* Application object: MILLING_TECHNOLOGY (#528)
* SPINDLE: #528, #529, #530, #531, #532
* FEEDRATE: #528, #533, #534, #535, #536
*/
#528=MACHINING_TECHNOLOGY('','milling','','');
#529=ACTION_PROPERTY('spindle','milling',#528);
#530=ACTION_PROPERTY_REPRESENTATION('rotational speed','milling',#529,#531);
#531=MACHINING_SPINDLE_SPEED_REPRESENTATION('spindle speed',(#532),#41);
#532=MEASURE_REPRESENTATION_ITEM('rotational speed',NUMERIC_MEASURE(0.),
#483);
#533=ACTION_PROPERTY('feedrate','milling',#528);
#534=ACTION_PROPERTY_REPRESENTATION('feed speed','milling',#533,#535);
#535=MACHINING_FEED_SPEED_REPRESENTATION('feed speed',(#536),#41);
#536=MEASURE_REPRESENTATION_ITEM('feed speed',NUMERIC_MEASURE(0.),#486);

/*****
* Application object: MILLING_TECHNOLOGY (#537)
* SPINDLE: #537, #538, #539, #540, #541
* FEEDRATE: #537, #542, #543, #544, #545
*/
#537=MACHINING_TECHNOLOGY('','milling','','');
#538=ACTION_PROPERTY('spindle','milling',#537);
#539=ACTION_PROPERTY_REPRESENTATION('rotational speed','milling',#538,#540);
#540=MACHINING_SPINDLE_SPEED_REPRESENTATION('spindle speed',(#541),#41);
#541=MEASURE_REPRESENTATION_ITEM('rotational speed',NUMERIC_MEASURE(0.),
#483);
#542=ACTION_PROPERTY('feedrate','milling',#537);
#543=ACTION_PROPERTY_REPRESENTATION('feed speed','milling',#542,#544);
#544=MACHINING_FEED_SPEED_REPRESENTATION('feed speed',(#545),#41);
#545=MEASURE_REPRESENTATION_ITEM('feed speed',NUMERIC_MEASURE(250.),#486);

/*****
* Application object: NAMED_UNIT (#546)
*/
#546=(
NAMED_UNIT(*)
SI_UNIT($,.SECOND.)
TIME_UNIT()
);

/*****
* Application object: NAMED_UNIT (#547)
*/

```

ISO 10303-238:2007(E)

```
#547=(
CONVERSION_BASED_UNIT('minute',#549)
NAMED_UNIT(#548)
TIME_UNIT()
);
#548=DIMENSIONAL_EXPONENTS(0.,0.,1.,0.,0.,0.,0.);
#549=TIME_MEASURE_WITH_UNIT(TIME_MEASURE(60.),#546);

/*****
 * Application object: NAMED_UNIT (#550)
 */
#550=(
NAMED_UNIT(*)
PLANE_ANGLE_UNIT()
SI_UNIT($,.RADIAN.)
);

/*****
 * Application object: NAMED_UNIT (#551)
 */
#551=(
CONVERSION_BASED_UNIT('degree',#553)
NAMED_UNIT(#552)
PLANE_ANGLE_UNIT()
);
#552=DIMENSIONAL_EXPONENTS(0.,0.,0.,0.,0.,0.,0.);
#553=PLANE_ANGLE_MEASURE_WITH_UNIT(PLANE_ANGLE_MEASURE(0.01745329252),#550);

/*****
 * Application object: NAMED_UNIT (#554)
 */
#554=(
LENGTH_UNIT()
NAMED_UNIT(*)
SI_UNIT(.MILLI.,.METRE.)
);

/*****
 * Application object: NAMED_UNIT (#558)
 */
#558=(
NAMED_UNIT(*)
SI_UNIT($,.STERADIAN.)
SOLID_ANGLE_UNIT()
);

/*****
 * Application object: TOOLPATH_FEATURE (#567)
 * ITS_WORKPIECE: #567, #20, #19
 * FEATURE_PLACEMENT: #567, #568, #569, #570, #571
 * ITS_ID: #567 ['']
 * ITS_OPERATIONS [*]: #567, #510, #509, #508, #507, #505, #506, #490
 */
```



```

#567=INSTANCED_FEATURE('', 'toolpath', '', 'toolpath', #20, .F.);
#568=PRODUCT_DEFINITION_SHAPE('orientation', 'toolpath', #567);
#569=SHAPE_DEFINITION_REPRESENTATION(#568, #570);
#570=SHAPE_REPRESENTATION_WITH_PARAMETERS('', (#571), #42);
#571=AXIS2_PLACEMENT_3D('orientation', #572, #66, #67);
#572=CARTESIAN_POINT('origin', (0., 0., 0.));

/*****
* Application object: WORKPLAN (#575)
* ITS_ELEMENTS [1]: #575, #576, #505
* ITS_ID: #575 ['main workplan']
*/
#575=MACHINING_WORKPLAN('main workplan', '', '', '');
#576=MACHINING_PROCESS_SEQUENCE_RELATIONSHIP('', '', #575, #505, 1.);

/*****
* Application object: ENDMILL (#580)
* ITS_ID: #580 ['1']
* EFFECTIVE_CUTTING_DIAMETER: #580, #582, #583, #584, #585
* MAXIMUM_DEPTH_OF_CUT: #580, #582, #583, #584, #586
* HAND_OF_CUT: #580, #582, #583, #584, #587 ['right']
* EDGE_RADIUS: #580, #582, #583, #584, #588
*/
#580=MACHINING_TOOL('1', 'endmill', (#490), #581);
#581=ACTION_RESOURCE_TYPE('milling cutting tool');
#582=RESOURCE_PROPERTY('tool body', '', #580);
#583=RESOURCE_PROPERTY_REPRESENTATION('', '', #582, #584);
#584=MACHINING_TOOL_BODY_REPRESENTATION('endmill', (#585, #586, #587, #588), #41);
#585=(
LENGTH_MEASURE_WITH_UNIT()
MEASURE_REPRESENTATION_ITEM()
MEASURE_WITH_UNIT(LENGTH_MEASURE(20.), #554)
REPRESENTATION_ITEM('effective cutting diameter')
);
#586=(
LENGTH_MEASURE_WITH_UNIT()
MEASURE_REPRESENTATION_ITEM()
MEASURE_WITH_UNIT(LENGTH_MEASURE(20.), #554)
REPRESENTATION_ITEM('maximum depth of cut')
);
#587=DESCRIPTIVE_REPRESENTATION_ITEM('hand of cut', 'right');
#588=(
LENGTH_MEASURE_WITH_UNIT()
MEASURE_REPRESENTATION_ITEM()
MEASURE_WITH_UNIT(LENGTH_MEASURE(0.), #554)
REPRESENTATION_ITEM('edge radius')
);

#600=APPLICATION_PROTOCOL_DEFINITION('international standard',
'integrated_cnc_schema', 2006, #17);
ENDSEC;
END-ISO-10303-21;

```

## J.5 Data set for CC2 example

The example below is a conformance class two (CC2) data set for the project described in J.3. This describes the same machining workplan and toolpaths as the previous CC1 example, but also contains shape descriptions for both the workpiece and rawpiece.

```
ISO-10303-21;
HEADER;

FILE_DESCRIPTION(
/* description */ ('AP238 CC2 simple block example'),
/* implementation_level */ ('2;1'));

FILE_NAME(
/* name */ ('simple_block_cc2'),
/* time_stamp */ ('2006-07-06T12:30:22-04:00'),
/* author */ ('Dave Loffredo (loffredo@steptools.com)'),
/* organization */ (''),
/* preprocessor_version */ ('ST-DEVELOPER v11'),
/* originating_system */ ('Various'),
/* authorisation */ (''));

FILE_SCHEMA (('INTEGRATED_CNC_SCHEMA'));
ENDSEC;

DATA;

/*****
* Application object: PROJECT (#10)
* MAIN_WORKPLAN: #10, #11, #12, #1134
* ITS_ID: #10, #13, #14 ['New Project']
* ITS_WORKPIECES [*]: #10, #15, #19
*/
#10=PRODUCT_DEFINITION('','',#13,#16);
#11=PROCESS_PRODUCT_ASSOCIATION('','',#10,#12);
#12=PRODUCT_DEFINITION_PROCESS('machining','',#1134,'');
#13=PRODUCT_DEFINITION_FORMATION('','',#14);
#14=MACHINING_PROJECT('New Project','',$(#18));
#15=MACHINING_PROJECT_WORKPIECE_RELATIONSHIP('','workpiece','',#10,#19);
#16=PRODUCT_DEFINITION_CONTEXT('CNC Machining',#17,'manufacturing');
#17=APPLICATION_CONTEXT(
'Application protocol for the exchange of CNC data');
#18=PRODUCT_CONTEXT('CNC Machining',#17,'manufacturing');

/*****
* Application object: WORKPIECE (#19)
* ITS_ID: #19, #24, #25 ['WP']
* ITS_SUBASSEMBLY [*]: #19, #536
* ITS_GEOMETRY: #19, #20, #21, #22
* ITS_RAWPIECE: #19, #23, #315
*/
#19=PRODUCT_DEFINITION('','',#24,#16);
#20=PRODUCT_DEFINITION_SHAPE('','',#19);
```

```

#21=SHAPE_DEFINITION_REPRESENTATION(#20,#22);
#22=SHAPE_REPRESENTATION('parent',(#29),#1026);
#23=MAKE_FROM_USAGE_OPTION('',' ',#19,#315,0,'',#33);
#24=PRODUCT_DEFINITION_FORMATION('1.0','Workpiece',#25);
#25=PRODUCT('WP','AP-238 CC2',' ',(#18));
#29=AXIS2_PLACEMENT_3D('owner',#30,#31,#32);
#30=CARTESIAN_POINT('owner',(0.,0.,0.));
#31=DIRECTION('owner',(0.,0.,1.));
#32=DIRECTION('owner',(1.,0.,0.));
#33=MEASURE_WITH_UNIT(COUNT_MEASURE(1.),#1099);

/*****
* Application object: WORKPIECE (#34)
* ITS_ID: #34, #38, #39 ['WORKPIECE COMPONENT']
* ITS_APPROVALS: #34, #44
* ITS_GEOMETRY: #34, #35, #42, #43
* ITS_RELATED_GEOMETRY [*]: #34, #35, #42, #43, #47, #48
* ITS_TIMESTAMPS: #34, #36
* PRODUCT_PEOPLE: #34, #38, #39, #40
* REVISION_APPROVALS: #34, #38, #49, #510
* REVISION_PEOPLE: #34, #38, #45
* REVISION_PEOPLE: #34, #38, #50
*/
#34=PRODUCT_DEFINITION('WORKPIECE COMPONENT','',#38,#16);
#35=PRODUCT_DEFINITION_SHAPE('','',#34);
#36=APPLIED_DATE_AND_TIME_ASSIGNMENT(#37,#52,(#34));
#37=DATE_AND_TIME(#56,#57);
#38=PRODUCT_DEFINITION_FORMATION(' ',' ',#39);
#39=PRODUCT('loffDE0Bxyzt','loffDE0Bxyzt',' ',(#18));
#40=APPLIED_PERSON_AND_ORGANIZATION_ASSIGNMENT(#41,#53,(#39));
#41=PERSON_AND_ORGANIZATION(#1101,#59);
#42=SHAPE_DEFINITION_REPRESENTATION(#35,#43);
#43=SHAPE_REPRESENTATION('loffDE0Bxyzt-none',(#60),#1026);
#44=APPLIED_APPROVAL_ASSIGNMENT(#516,(#34));
#45=APPLIED_PERSON_AND_ORGANIZATION_ASSIGNMENT(#46,#54,(#38));
#46=PERSON_AND_ORGANIZATION(#1101,#64);
#47=SHAPE_REPRESENTATION_RELATIONSHIP('none',
'relationship between loffDE0Bxyzt-none and loffDE0Bxyzt-none',#43,#48);
#48=ADVANCED_BREP_SHAPE_REPRESENTATION('loffDE0Bxyzt-none',(#65),#1026);
#49=APPLIED_APPROVAL_ASSIGNMENT(#510,(#38));
#50=APPLIED_PERSON_AND_ORGANIZATION_ASSIGNMENT(#51,#55,(#34,#38));
#51=PERSON_AND_ORGANIZATION(#1101,#314);
#52=DATE_TIME_ROLE('creation_date');
#53=PERSON_AND_ORGANIZATION_ROLE('design_owner');
#54=PERSON_AND_ORGANIZATION_ROLE('design_supplier');
#55=PERSON_AND_ORGANIZATION_ROLE('creator');
#56=CALENDAR_DATE(0,1,1);
#57=LOCAL_TIME(0,0,0.,#58);
#58=COORDINATED_UNIVERSAL_TIME_OFFSET(0,0,.BEHIND.);
#59=ORGANIZATION(' ',' ',' ');
#60=AXIS2_PLACEMENT_3D('child',#61,#62,#63);
#61=CARTESIAN_POINT('child',(0.,0.,0.));
#62=DIRECTION('child',(0.,0.,1.));
#63=DIRECTION('child',(1.,0.,0.));

```

```

#64=ORGANIZATION(' ',' ',' ');
#65=MANIFOLD_SOLID_BREP('WORKPIECE',#66);
#66=CLOSED_SHELL('',( #67,#123,#170,#208,#232,#249,#261,#285,#302));
#67=ADVANCED_FACE('WPface0',( #68),#118,.T.);
#68=FACE_OUTER_BOUND('',#69,.T.);
#69=EDGE_LOOP('',( #70,#80,#88,#96,#104,#112));
#70=ORIENTED_EDGE('',*,*,#71,.F.);
#71=EDGE_CURVE('',#72,#74,#76,.T.);
#72=VERTEX_POINT('',#73);
#73=CARTESIAN_POINT('',(90.,0.,15.));
#74=VERTEX_POINT('',#75);
#75=CARTESIAN_POINT('',(90.,90.,15.));
#76=LINE('',#77,#78);
#77=CARTESIAN_POINT('',(90.,45.,15.));
#78=VECTOR('',#79,1.);
#79=DIRECTION('',(0.,1.,0.));
#80=ORIENTED_EDGE('',*,*,#81,.F.);
#81=EDGE_CURVE('',#82,#72,#84,.T.);
#82=VERTEX_POINT('',#83);
#83=CARTESIAN_POINT('',(100.,0.,15.));
#84=LINE('',#85,#86);
#85=CARTESIAN_POINT('',(50.,0.,15.));
#86=VECTOR('',#87,1.);
#87=DIRECTION('',(-1.,0.,0.));
#88=ORIENTED_EDGE('',*,*,#89,.F.);
#89=EDGE_CURVE('',#90,#82,#92,.T.);
#90=VERTEX_POINT('',#91);
#91=CARTESIAN_POINT('',(100.,100.,15.));
#92=LINE('',#93,#94);
#93=CARTESIAN_POINT('',(100.,50.,15.));
#94=VECTOR('',#95,1.);
#95=DIRECTION('',(0.,-1.,0.));
#96=ORIENTED_EDGE('',*,*,#97,.F.);
#97=EDGE_CURVE('',#98,#90,#100,.T.);
#98=VERTEX_POINT('',#99);
#99=CARTESIAN_POINT('',(0.,100.,15.));
#100=LINE('',#101,#102);
#101=CARTESIAN_POINT('',(50.,100.,15.));
#102=VECTOR('',#103,1.);
#103=DIRECTION('',(1.,0.,0.));
#104=ORIENTED_EDGE('',*,*,#105,.F.);
#105=EDGE_CURVE('',#106,#98,#108,.T.);
#106=VERTEX_POINT('',#107);
#107=CARTESIAN_POINT('',(0.,90.,15.));
#108=LINE('',#109,#110);
#109=CARTESIAN_POINT('',(0.,50.,15.));
#110=VECTOR('',#111,1.);
#111=DIRECTION('',(0.,1.,0.));
#112=ORIENTED_EDGE('',*,*,#113,.F.);
#113=EDGE_CURVE('',#74,#106,#114,.T.);
#114=LINE('',#115,#116);
#115=CARTESIAN_POINT('',(45.,90.,15.));
#116=VECTOR('',#117,1.);
#117=DIRECTION('',(-1.,0.,0.));

```

```

#118=PLANE('',#119);
#119=AXIS2_PLACEMENT_3D('',#120,#121,#122);
#120=CARTESIAN_POINT('',(50.,50.,15.));
#121=DIRECTION('',(0.,0.,1.));
#122=DIRECTION('',(1.,0.,0.));
#123=ADVANCED_FACE('WPface1',(#124),#165,.T.);
#124=FACE_OUTER_BOUND('',#125,.T.);
#125=EDGE_LOOP('',(#126,#134,#135,#143,#151,#159));
#126=ORIENTED_EDGE('',*,*,#127,.T.);
#127=EDGE_CURVE('',#128,#82,#130,.T.);
#128=VERTEX_POINT('',#129);
#129=CARTESIAN_POINT('',(100.,0.,0.));
#130=LINE('',#131,#132);
#131=CARTESIAN_POINT('',(100.,0.,0.));
#132=VECTOR('',#133,1.);
#133=DIRECTION('',(0.,0.,1.));
#134=ORIENTED_EDGE('',*,*,#81,.T.);
#135=ORIENTED_EDGE('',*,*,#136,.T.);
#136=EDGE_CURVE('',#72,#137,#139,.T.);
#137=VERTEX_POINT('',#138);
#138=CARTESIAN_POINT('',(90.,0.,25.));
#139=LINE('',#140,#141);
#140=CARTESIAN_POINT('',(90.,0.,15.));
#141=VECTOR('',#142,1.);
#142=DIRECTION('',(0.,0.,1.));
#143=ORIENTED_EDGE('',*,*,#144,.T.);
#144=EDGE_CURVE('',#137,#145,#147,.T.);
#145=VERTEX_POINT('',#146);
#146=CARTESIAN_POINT('',(0.,0.,25.));
#147=LINE('',#148,#149);
#148=CARTESIAN_POINT('',(45.,0.,25.));
#149=VECTOR('',#150,1.);
#150=DIRECTION('',(-1.,0.,0.));
#151=ORIENTED_EDGE('',*,*,#152,.F.);
#152=EDGE_CURVE('',#153,#145,#155,.T.);
#153=VERTEX_POINT('',#154);
#154=CARTESIAN_POINT('',(0.,0.,0.));
#155=LINE('',#156,#157);
#156=CARTESIAN_POINT('',(0.,0.,0.));
#157=VECTOR('',#158,1.);
#158=DIRECTION('',(0.,0.,1.));
#159=ORIENTED_EDGE('',*,*,#160,.T.);
#160=EDGE_CURVE('',#153,#128,#161,.T.);
#161=LINE('',#162,#163);
#162=CARTESIAN_POINT('',(50.,0.,0.));
#163=VECTOR('',#164,1.);
#164=DIRECTION('',(1.,0.,0.));
#165=PLANE('',#166);
#166=AXIS2_PLACEMENT_3D('',#167,#168,#169);
#167=CARTESIAN_POINT('',(50.,0.,0.));
#168=DIRECTION('',(0.,-1.,0.));
#169=DIRECTION('',(0.,0.,-1.));
#170=ADVANCED_FACE('WPface2',(#171),#203,.T.);
#171=FACE_OUTER_BOUND('',#172,.T.);

```

```

#172=EDGE_LOOP('', (#173, #174, #182, #188, #189, #197));
#173=ORIENTED_EDGE('', *, *, #152, .T.);
#174=ORIENTED_EDGE('', *, *, #175, .T.);
#175=EDGE_CURVE('', #145, #176, #178, .T.);
#176=VERTEX_POINT('', #177);
#177=CARTESIAN_POINT('', (0., 90., 25.));
#178=LINE('', #179, #180);
#179=CARTESIAN_POINT('', (0., 45., 25.));
#180=VECTOR('', #181, 1.);
#181=DIRECTION('', (0., 1., 0.));
#182=ORIENTED_EDGE('', *, *, #183, .F.);
#183=EDGE_CURVE('', #106, #176, #184, .T.);
#184=LINE('', #185, #186);
#185=CARTESIAN_POINT('', (0., 90., 15.));
#186=VECTOR('', #187, 1.);
#187=DIRECTION('', (0., 0., 1.));
#188=ORIENTED_EDGE('', *, *, #105, .T.);
#189=ORIENTED_EDGE('', *, *, #190, .F.);
#190=EDGE_CURVE('', #191, #98, #193, .T.);
#191=VERTEX_POINT('', #192);
#192=CARTESIAN_POINT('', (0., 100., 0.));
#193=LINE('', #194, #195);
#194=CARTESIAN_POINT('', (0., 100., 0.));
#195=VECTOR('', #196, 1.);
#196=DIRECTION('', (0., 0., 1.));
#197=ORIENTED_EDGE('', *, *, #198, .T.);
#198=EDGE_CURVE('', #191, #153, #199, .T.);
#199=LINE('', #200, #201);
#200=CARTESIAN_POINT('', (0., 50., 0.));
#201=VECTOR('', #202, 1.);
#202=DIRECTION('', (0., -1., 0.));
#203=PLANE('', #204);
#204=AXIS2_PLACEMENT_3D('', #205, #206, #207);
#205=CARTESIAN_POINT('', (0., 50., 0.));
#206=DIRECTION('', (-1., 0., 0.));
#207=DIRECTION('', (0., 0., 1.));
#208=ADVANCED_FACE('WPface3', (#209), #227, .T.);
#209=FACE_OUTER_BOUND('', #210, .T.);
#210=EDGE_LOOP('', (#211, #212, #213, #221));
#211=ORIENTED_EDGE('', *, *, #190, .T.);
#212=ORIENTED_EDGE('', *, *, #97, .T.);
#213=ORIENTED_EDGE('', *, *, #214, .F.);
#214=EDGE_CURVE('', #215, #90, #217, .T.);
#215=VERTEX_POINT('', #216);
#216=CARTESIAN_POINT('', (100., 100., 0.));
#217=LINE('', #218, #219);
#218=CARTESIAN_POINT('', (100., 100., 0.));
#219=VECTOR('', #220, 1.);
#220=DIRECTION('', (0., 0., 1.));
#221=ORIENTED_EDGE('', *, *, #222, .T.);
#222=EDGE_CURVE('', #215, #191, #223, .T.);
#223=LINE('', #224, #225);
#224=CARTESIAN_POINT('', (50., 100., 0.));
#225=VECTOR('', #226, 1.);

```

```

#226=DIRECTION('',(-1.,0.,0.));
#227=PLANE('',#228);
#228=AXIS2_PLACEMENT_3D('',#229,#230,#231);
#229=CARTESIAN_POINT('',(50.,100.,0.));
#230=DIRECTION('',(0.,1.,0.));
#231=DIRECTION('',(0.,0.,1.));
#232=ADVANCED_FACE('WPface4',(#233),#244,.T.);
#233=FACE_OUTER_BOUND('',#234,.T.);
#234=EDGE_LOOP('',(#235,#241,#242,#243));
#235=ORIENTED_EDGE('',*,*,#236,.F.);
#236=EDGE_CURVE('',#128,#215,#237,.T.);
#237=LINE('',#238,#239);
#238=CARTESIAN_POINT('',(100.,50.,0.));
#239=VECTOR('',#240,1.);
#240=DIRECTION('',(0.,1.,0.));
#241=ORIENTED_EDGE('',*,*,#160,.F.);
#242=ORIENTED_EDGE('',*,*,#198,.F.);
#243=ORIENTED_EDGE('',*,*,#222,.F.);
#244=PLANE('',#245);
#245=AXIS2_PLACEMENT_3D('',#246,#247,#248);
#246=CARTESIAN_POINT('',(50.,50.,0.));
#247=DIRECTION('',(0.,0.,-1.));
#248=DIRECTION('',(-1.,0.,0.));
#249=ADVANCED_FACE('WPface5',(#250),#256,.T.);
#250=FACE_OUTER_BOUND('',#251,.T.);
#251=EDGE_LOOP('',(#252,#253,#254,#255));
#252=ORIENTED_EDGE('',*,*,#236,.T.);
#253=ORIENTED_EDGE('',*,*,#214,.T.);
#254=ORIENTED_EDGE('',*,*,#89,.T.);
#255=ORIENTED_EDGE('',*,*,#127,.F.);
#256=PLANE('',#257);
#257=AXIS2_PLACEMENT_3D('',#258,#259,#260);
#258=CARTESIAN_POINT('',(100.,50.,0.));
#259=DIRECTION('',(1.,0.,0.));
#260=DIRECTION('',(0.,0.,-1.));
#261=ADVANCED_FACE('WPface6',(#262),#280,.T.);
#262=FACE_OUTER_BOUND('',#263,.T.);
#263=EDGE_LOOP('',(#264,#265,#273,#279));
#264=ORIENTED_EDGE('',*,*,#144,.F.);
#265=ORIENTED_EDGE('',*,*,#266,.F.);
#266=EDGE_CURVE('',#267,#137,#269,.T.);
#267=VERTEX_POINT('',#268);
#268=CARTESIAN_POINT('',(90.,90.,25.));
#269=LINE('',#270,#271);
#270=CARTESIAN_POINT('',(90.,45.,25.));
#271=VECTOR('',#272,1.);
#272=DIRECTION('',(0.,-1.,0.));
#273=ORIENTED_EDGE('',*,*,#274,.F.);
#274=EDGE_CURVE('',#176,#267,#275,.T.);
#275=LINE('',#276,#277);
#276=CARTESIAN_POINT('',(45.,90.,25.));
#277=VECTOR('',#278,1.);
#278=DIRECTION('',(1.,0.,0.));
#279=ORIENTED_EDGE('',*,*,#175,.F.);

```

```

#280=PLANE('', #281);
#281=AXIS2_PLACEMENT_3D('', #282, #283, #284);
#282=CARTESIAN_POINT('', (45., 45., 25.));
#283=DIRECTION('', (0., 0., 1.));
#284=DIRECTION('', (1., 0., 0.));
#285=ADVANCED_FACE('WPface7', (#286), #297, .T.);
#286=FACE_OUTER_BOUND('', #287, .T.);
#287=EDGE_LOOP('', (#288, #289, #290, #296));
#288=ORIENTED_EDGE('', *, *, #183, .T.);
#289=ORIENTED_EDGE('', *, *, #274, .T.);
#290=ORIENTED_EDGE('', *, *, #291, .F.);
#291=EDGE_CURVE('', #74, #267, #292, .T.);
#292=LINE('', #293, #294);
#293=CARTESIAN_POINT('', (90., 90., 15.));
#294=VECTOR('', #295, 1.);
#295=DIRECTION('', (0., 0., 1.));
#296=ORIENTED_EDGE('', *, *, #113, .T.);
#297=PLANE('', #298);
#298=AXIS2_PLACEMENT_3D('', #299, #300, #301);
#299=CARTESIAN_POINT('', (45., 90., 15.));
#300=DIRECTION('', (0., 1., 0.));
#301=DIRECTION('', (0., 0., 1.));
#302=ADVANCED_FACE('WPface8', (#303), #309, .T.);
#303=FACE_OUTER_BOUND('', #304, .T.);
#304=EDGE_LOOP('', (#305, #306, #307, #308));
#305=ORIENTED_EDGE('', *, *, #71, .T.);
#306=ORIENTED_EDGE('', *, *, #291, .T.);
#307=ORIENTED_EDGE('', *, *, #266, .T.);
#308=ORIENTED_EDGE('', *, *, #136, .F.);
#309=PLANE('', #310);
#310=AXIS2_PLACEMENT_3D('', #311, #312, #313);
#311=CARTESIAN_POINT('', (90., 45., 15.));
#312=DIRECTION('', (1., 0., 0.));
#313=DIRECTION('', (0., 0., -1.));
#314=ORGANIZATION(' ', ' ', ' ');

/*****
* Application object: WORKPIECE (#315)
* ITS_ID: #315, #319, #320 ['RAWPIECE']
* ITS_SUBASSEMBLY [*]: #315, #541
* ITS_GEOMETRY: #315, #316, #317, #318
*/
#315=PRODUCT_DEFINITION('RAW', '', #319, #16);
#316=PRODUCT_DEFINITION_SHAPE('', '', #315);
#317=SHAPE_DEFINITION_REPRESENTATION(#316, #318);
#318=SHAPE_REPRESENTATION('parent', (#324), #1028);
#319=PRODUCT_DEFINITION_FORMATION('1.0', 'Workpiece', #320);
#320=PRODUCT('RAW', 'AP-238 CC2', ' ', (#18));
#324=AXIS2_PLACEMENT_3D('owner', #325, #326, #327);
#325=CARTESIAN_POINT('owner', (0., 0., 0.));
#326=DIRECTION('owner', (0., 0., 1.));
#327=DIRECTION('owner', (1., 0., 0.));

/*****

```



```

* Application object: WORKPIECE (#328)
* ITS_ID: #328, #332, #333 ['RAWPIECE COMPONENT']
* ITS_APPROVALS: #328, #338
* ITS_GEOMETRY: #328, #329, #336, #337
* ITS_RELATED_GEOMETRY [*]: #328, #329, #336, #337, #341, #342
* ITS_TIMESTAMPS: #328, #330
* PRODUCT_PEOPLE: #328, #332, #333, #334
* REVISION_APPROVALS: #328, #332, #343
* REVISION_PEOPLE: #328, #332, #339
* REVISION_PEOPLE: #328, #332, #344, #345
*/
#328=PRODUCT_DEFINITION('RAWPIECE COMPONENT',' ',#332,#16);
#329=PRODUCT_DEFINITION_SHAPE(' ',' ',#328);
#330=APPLIED_DATE_AND_TIME_ASSIGNMENT(#331,#346,(#328));
#331=DATE_AND_TIME(#350,#351);
#332=PRODUCT_DEFINITION_FORMATION(' ',' ',#333);
#333=PRODUCT('RAWPIECE COMPONENT','loffDE0Bxyzv',' ',(#18));
#334=APPLIED_PERSON_AND_ORGANIZATION_ASSIGNMENT(#335,#347,(#333));
#335=PERSON_AND_ORGANIZATION(#1102,#353);
#336=SHAPE_DEFINITION_REPRESENTATION(#329,#337);
#337=SHAPE_REPRESENTATION('loffDE0Bxyzv-none',(#354),#1028);
#338=APPLIED_APPROVAL_ASSIGNMENT(#523,(#328));
#339=APPLIED_PERSON_AND_ORGANIZATION_ASSIGNMENT(#340,#348,(#332));
#340=PERSON_AND_ORGANIZATION(#1102,#358);
#341=SHAPE_REPRESENTATION_RELATIONSHIP('none',
'relationship between loffDE0Bxyzv-none and loffDE0Bxyzv-none',#337,#342);
#342=ADVANCED_BREP_SHAPE_REPRESENTATION('loffDE0Bxyzv-none',(#359),#1028);
#343=APPLIED_APPROVAL_ASSIGNMENT(#517,(#332));
#344=APPLIED_PERSON_AND_ORGANIZATION_ASSIGNMENT(#345,#349,(#328,#332));
#345=PERSON_AND_ORGANIZATION(#1102,#509);
#346=DATE_TIME_ROLE('creation_date');
#347=PERSON_AND_ORGANIZATION_ROLE('design_owner');
#348=PERSON_AND_ORGANIZATION_ROLE('design_supplier');
#349=PERSON_AND_ORGANIZATION_ROLE('creator');
#350=CALENDAR_DATE(0,1,1);
#351=LOCAL_TIME(0,0,0.,#352);
#352=COORDINATED_UNIVERSAL_TIME_OFFSET(0,0,.BEHIND.);
#353=ORGANIZATION(' ',' ',' ');
#354=AXIS2_PLACEMENT_3D('child',#355,#356,#357);
#355=CARTESIAN_POINT('child',(0.,0.,0.));
#356=DIRECTION('child',(0.,0.,1.));
#357=DIRECTION('child',(1.,0.,0.));
#358=ORGANIZATION(' ',' ',' ');
#359=MANIFOLD_SOLID_BREP('RAWPIECE',#360);
#360=CLOSED_SHELL(' ',(#361,#401,#432,#456,#480,#497));
#361=ADVANCED_FACE('RPface0',(#362),#396,.T.);
#362=FACE_OUTER_BOUND(' ',#363,.T.);
#363=EDGE_LOOP(' ',(#364,#374,#382,#390));
#364=ORIENTED_EDGE(' ',*,*,#365,.F.);
#365=EDGE_CURVE(' ',#366,#368,#370,.T.);
#366=VERTEX_POINT(' ',#367);
#367=CARTESIAN_POINT(' ',(100.,0.,25.));
#368=VERTEX_POINT(' ',#369);
#369=CARTESIAN_POINT(' ',(0.,0.,25.));

```

```

#370=LINE ('', #371, #372);
#371=CARTESIAN_POINT ('', (50., 0., 25.));
#372=VECTOR ('', #373, 1.);
#373=DIRECTION ('', (-1., 0., 0.));
#374=ORIENTED_EDGE ('', *, *, #375, .F.);
#375=EDGE_CURVE ('', #376, #366, #378, .T.);
#376=VERTEX_POINT ('', #377);
#377=CARTESIAN_POINT ('', (100., 100., 25.));
#378=LINE ('', #379, #380);
#379=CARTESIAN_POINT ('', (100., 50., 25.));
#380=VECTOR ('', #381, 1.);
#381=DIRECTION ('', (0., -1., 0.));
#382=ORIENTED_EDGE ('', *, *, #383, .F.);
#383=EDGE_CURVE ('', #384, #376, #386, .T.);
#384=VERTEX_POINT ('', #385);
#385=CARTESIAN_POINT ('', (0., 100., 25.));
#386=LINE ('', #387, #388);
#387=CARTESIAN_POINT ('', (50., 100., 25.));
#388=VECTOR ('', #389, 1.);
#389=DIRECTION ('', (1., 0., 0.));
#390=ORIENTED_EDGE ('', *, *, #391, .F.);
#391=EDGE_CURVE ('', #368, #384, #392, .T.);
#392=LINE ('', #393, #394);
#393=CARTESIAN_POINT ('', (0., 50., 25.));
#394=VECTOR ('', #395, 1.);
#395=DIRECTION ('', (0., 1., 0.));
#396=PLANE ('', #397);
#397=AXIS2_PLACEMENT_3D ('', #398, #399, #400);
#398=CARTESIAN_POINT ('', (50., 50., 25.));
#399=DIRECTION ('', (0., 0., 1.));
#400=DIRECTION ('', (1., 0., 0.));
#401=ADVANCED_FACE ('RFace1', (#402), #427, .T.);
#402=FACE_OUTER_BOUND ('', #403, .T.);
#403=EDGE_LOOP ('', (#404, #412, #413, #421));
#404=ORIENTED_EDGE ('', *, *, #405, .T.);
#405=EDGE_CURVE ('', #406, #366, #408, .T.);
#406=VERTEX_POINT ('', #407);
#407=CARTESIAN_POINT ('', (100., 0., 0.));
#408=LINE ('', #409, #410);
#409=CARTESIAN_POINT ('', (100., 0., 0.));
#410=VECTOR ('', #411, 1.);
#411=DIRECTION ('', (0., 0., 1.));
#412=ORIENTED_EDGE ('', *, *, #365, .T.);
#413=ORIENTED_EDGE ('', *, *, #414, .F.);
#414=EDGE_CURVE ('', #415, #368, #417, .T.);
#415=VERTEX_POINT ('', #416);
#416=CARTESIAN_POINT ('', (0., 0., 0.));
#417=LINE ('', #418, #419);
#418=CARTESIAN_POINT ('', (0., 0., 0.));
#419=VECTOR ('', #420, 1.);
#420=DIRECTION ('', (0., 0., 1.));
#421=ORIENTED_EDGE ('', *, *, #422, .T.);
#422=EDGE_CURVE ('', #415, #406, #423, .T.);
#423=LINE ('', #424, #425);

```

```

#424=CARTESIAN_POINT('', (50.,0.,0.));
#425=VECTOR('', #426,1.);
#426=DIRECTION('', (1.,0.,0.));
#427=PLANE('', #428);
#428=AXIS2_PLACEMENT_3D('', #429, #430, #431);
#429=CARTESIAN_POINT('', (50.,0.,0.));
#430=DIRECTION('', (0.,-1.,0.));
#431=DIRECTION('', (0.,0.,-1.));
#432=ADVANCED_FACE('RPface2', (#433), #451, .T.);
#433=FACE_OUTER_BOUND('', #434, .T.);
#434=EDGE_LOOP('', (#435, #436, #437, #445));
#435=ORIENTED_EDGE('', *, *, #414, .T.);
#436=ORIENTED_EDGE('', *, *, #391, .T.);
#437=ORIENTED_EDGE('', *, *, #438, .F.);
#438=EDGE_CURVE('', #439, #384, #441, .T.);
#439=VERTEX_POINT('', #440);
#440=CARTESIAN_POINT('', (0.,100.,0.));
#441=LINE('', #442, #443);
#442=CARTESIAN_POINT('', (0.,100.,0.));
#443=VECTOR('', #444,1.);
#444=DIRECTION('', (0.,0.,1.));
#445=ORIENTED_EDGE('', *, *, #446, .T.);
#446=EDGE_CURVE('', #439, #415, #447, .T.);
#447=LINE('', #448, #449);
#448=CARTESIAN_POINT('', (0.,50.,0.));
#449=VECTOR('', #450,1.);
#450=DIRECTION('', (0.,-1.,0.));
#451=PLANE('', #452);
#452=AXIS2_PLACEMENT_3D('', #453, #454, #455);
#453=CARTESIAN_POINT('', (0.,50.,0.));
#454=DIRECTION('', (-1.,0.,0.));
#455=DIRECTION('', (0.,0.,1.));
#456=ADVANCED_FACE('RPface3', (#457), #475, .T.);
#457=FACE_OUTER_BOUND('', #458, .T.);
#458=EDGE_LOOP('', (#459, #460, #461, #469));
#459=ORIENTED_EDGE('', *, *, #438, .T.);
#460=ORIENTED_EDGE('', *, *, #383, .T.);
#461=ORIENTED_EDGE('', *, *, #462, .F.);
#462=EDGE_CURVE('', #463, #376, #465, .T.);
#463=VERTEX_POINT('', #464);
#464=CARTESIAN_POINT('', (100.,100.,0.));
#465=LINE('', #466, #467);
#466=CARTESIAN_POINT('', (100.,100.,0.));
#467=VECTOR('', #468,1.);
#468=DIRECTION('', (0.,0.,1.));
#469=ORIENTED_EDGE('', *, *, #470, .T.);
#470=EDGE_CURVE('', #463, #439, #471, .T.);
#471=LINE('', #472, #473);
#472=CARTESIAN_POINT('', (50.,100.,0.));
#473=VECTOR('', #474,1.);
#474=DIRECTION('', (-1.,0.,0.));
#475=PLANE('', #476);
#476=AXIS2_PLACEMENT_3D('', #477, #478, #479);
#477=CARTESIAN_POINT('', (50.,100.,0.));

```

```

#478=DIRECTION('',(0.,1.,0.));
#479=DIRECTION('',(0.,0.,1.));
#480=ADVANCED_FACE('RPface4',(#481),#492,.T.);
#481=FACE_OUTER_BOUND('',#482,.T.);
#482=EDGE_LOOP('',(483,#489,#490,#491));
#483=ORIENTED_EDGE('',*,*,#484,.F.);
#484=EDGE_CURVE('',#406,#463,#485,.T.);
#485=LINE('',#486,#487);
#486=CARTESIAN_POINT('',(100.,50.,0.));
#487=VECTOR('',#488,1.);
#488=DIRECTION('',(0.,1.,0.));
#489=ORIENTED_EDGE('',*,*,#422,.F.);
#490=ORIENTED_EDGE('',*,*,#446,.F.);
#491=ORIENTED_EDGE('',*,*,#470,.F.);
#492=PLANE('',#493);
#493=AXIS2_PLACEMENT_3D('',#494,#495,#496);
#494=CARTESIAN_POINT('',(50.,50.,0.));
#495=DIRECTION('',(0.,0.,-1.));
#496=DIRECTION('',(-1.,0.,0.));
#497=ADVANCED_FACE('RPface5',(#498),#504,.T.);
#498=FACE_OUTER_BOUND('',#499,.T.);
#499=EDGE_LOOP('',(500,#501,#502,#503));
#500=ORIENTED_EDGE('',*,*,#484,.T.);
#501=ORIENTED_EDGE('',*,*,#462,.T.);
#502=ORIENTED_EDGE('',*,*,#375,.T.);
#503=ORIENTED_EDGE('',*,*,#405,.F.);
#504=PLANE('',#505);
#505=AXIS2_PLACEMENT_3D('',#506,#507,#508);
#506=CARTESIAN_POINT('',(100.,50.,0.));
#507=DIRECTION('',(1.,0.,0.));
#508=DIRECTION('',(0.,0.,-1.));
#509=ORGANIZATION(' ',' ',' ');

/*****
* Application object: APPROVAL (#510)
* PURPOSE: #510 ['']
* APPROVAL_DATE_TIME: #510, #511, #512
* STATUS: #510, #524
*/
#510=APPROVAL(#524,'');
#511=APPROVAL_DATE_TIME(#512,#510);
#512=DATE_AND_TIME(#513,#514);
#513=CALENDAR_DATE(0,1,1);
#514=LOCAL_TIME(0,0,0.,#515);
#515=COORDINATED_UNIVERSAL_TIME_OFFSET(0,0,.BEHIND.);

/*****
* Application object: APPROVAL (#516)
* PURPOSE: #516 [' ']
* STATUS: #516, #525
*/
#516=APPROVAL(#525,' ');

/*****

```

```

* Application object: APPROVAL (#517)
* PURPOSE: #517 ['']
* APPROVAL_DATE_TIME: #517, #518, #519
* STATUS: #517, #526
*/
#517=APPROVAL(#526, '');
#518=APPROVAL_DATE_TIME(#519, #517);
#519=DATE_AND_TIME(#520, #521);
#520=CALENDAR_DATE(0, 1, 1);
#521=LOCAL_TIME(0, 0, 0., #522);
#522=COORDINATED_UNIVERSAL_TIME_OFFSET(0, 0, .BEHIND.);

/*****
* Application object: APPROVAL (#523)
* PURPOSE: #523 ['']
* STATUS: #523, #527
*/
#523=APPROVAL(#527, ' ');

/*****
* Application object: APPROVAL_STATUS (#524)
* STATUS_NAME: #524 ['']
*/
#524=APPROVAL_STATUS('');

/*****
* Application object: APPROVAL_STATUS (#525)
* STATUS_NAME: #525 ['not_yet_approved']
*/
#525=APPROVAL_STATUS('not_yet_approved');

/*****
* Application object: APPROVAL_STATUS (#526)
* STATUS_NAME: #526 ['']
*/
#526=APPROVAL_STATUS('');

/*****
* Application object: APPROVAL_STATUS (#527)
* STATUS_NAME: #527 ['not_yet_approved']
*/
#527=APPROVAL_STATUS('not_yet_approved');

/*****
* Application object: APPROVING_PERSON_ORGANIZATION (#528)
* ROLE: #528, #529 ['approver']
* PERSON_ORGANIZATION: #528, #530
* AUTHORIZED_APPROVAL: #528, #510
*/
#528=APPROVAL_PERSON_ORGANIZATION(#530, #510, #529);
#529=APPROVAL_ROLE('approver');
#530=PERSON_AND_ORGANIZATION(#1101, #531);
#531=ORGANIZATION(' ', ' ', ' ');

```

```

/*****
* Application object: APPROVING_PERSON_ORGANIZATION (#532)
* ROLE: #532, #533 ['approver']
* PERSON_ORGANIZATION: #532, #534
* AUTHORIZED_APPROVAL: #532, #517
*/
#532=APPROVAL_PERSON_ORGANIZATION(#534,#517,#533);
#533=APPROVAL_ROLE('approver');
#534=PERSON_AND_ORGANIZATION(#1102,#535);
#535=ORGANIZATION(' ',' ',' ');

/*****
* Application object: ASSEMBLY (#536)
* ITEM_TRANSFORM: #536, #537, #538, #539, #540
* CHILD_WORKPIECE: #536, #34
*/
#536=NEXT_ASSEMBLY_USAGE_OCCURRENCE(' ',' ',#19,#34,'');
#537=PRODUCT_DEFINITION_SHAPE(' ',' ',#536);
#538=CONTEXT_DEPENDENT_SHAPE_REPRESENTATION(#539,#537);
#539=(
REPRESENTATION_RELATIONSHIP(' ',' ',#43,#22)
REPRESENTATION_RELATIONSHIP_WITH_TRANSFORMATION(#540)
SHAPE_REPRESENTATION_RELATIONSHIP()
);
#540=ITEM_DEFINED_TRANSFORMATION(' ',' ',#60,#29);

/*****
* Application object: ASSEMBLY (#541)
* ITEM_TRANSFORM: #541, #542, #543, #544, #545
* CHILD_WORKPIECE: #541, #328
*/
#541=NEXT_ASSEMBLY_USAGE_OCCURRENCE(' ',' ',#315,#328,'');
#542=PRODUCT_DEFINITION_SHAPE(' ',' ',#541);
#543=CONTEXT_DEPENDENT_SHAPE_REPRESENTATION(#544,#542);
#544=(
REPRESENTATION_RELATIONSHIP(' ',' ',#337,#318)
REPRESENTATION_RELATIONSHIP_WITH_TRANSFORMATION(#545)
SHAPE_REPRESENTATION_RELATIONSHIP()
);
#545=ITEM_DEFINED_TRANSFORMATION(' ',' ',#354,#324);

/*****
* Application object: CUTTER_LOCATION_TRAJECTORY (#546)
* ITS_TYPE: #546, #547, #548, #549, #550 ['trajectory path']
* ITS_TECHNOLOGY: #546, #551, #1053
* ITS_PRIORITY: #546, #552, #553, #554, #555 ['required']
* RAPID_SPEED: #546, #556, #557, #558, #559 ['true']
* ITS_ID: #546 ['WS 1 TP 1']
* BASICCURVE: #546, #560, #561, #562, #563
*/
#546=MACHINING_TOOLPATH('WS 1 TP 1','cutter location trajectory',' ',' ');
#547=ACTION_PROPERTY('trajectory type','cutter location trajectory',#546);
#548=ACTION_PROPERTY_REPRESENTATION(' ','cutter location trajectory',#547,
#549);

```

```

#549=REPRESENTATION('constant', (#550), #564);
#550=DESCRIPTIVE_REPRESENTATION_ITEM('constant', 'trajectory path');
#551=MACHINING_TECHNOLOGY_RELATIONSHIP('', 'cutter location trajectory', #546,
#1053);
#552=ACTION_PROPERTY('priority', 'cutter location trajectory', #546);
#553=ACTION_PROPERTY_REPRESENTATION('', 'cutter location trajectory', #552,
#554);
#554=REPRESENTATION('constant', (#555), #564);
#555=DESCRIPTIVE_REPRESENTATION_ITEM('constant', 'required');
#556=ACTION_PROPERTY('speed profile', 'rapid', #546);
#557=ACTION_PROPERTY_REPRESENTATION('', 'rapid', #556, #558);
#558=MACHINING_TOOLPATH_SPEED_PROFILE_REPRESENTATION('', (#559), #564);
#559=DESCRIPTIVE_REPRESENTATION_ITEM('', 'rapid');
#560=ACTION_PROPERTY('basic curve', 'cutter location trajectory', #546);
#561=ACTION_PROPERTY_REPRESENTATION('', 'cutter location trajectory', #560,
#562);
#562=REPRESENTATION('', (#563), #565);
#563=POLYLINE('basic curve for WS 1 TP 1', (#567, #568, #569));
#564=REPRESENTATION_CONTEXT('', 'units not necessary');
#565=(
GEOMETRIC_REPRESENTATION_CONTEXT(3)
GLOBAL_UNIT_ASSIGNED_CONTEXT((#1071, #1075, #1091))
REPRESENTATION_CONTEXT('MILLIMETRE DEGREE STERADIAN', '')
);
#567=CARTESIAN_POINT('start point', (0., 0., 40.));
#568=CARTESIAN_POINT('', (76.6078, 112.6997, 28.));
#569=CARTESIAN_POINT('', (76.6078, 112.6997, 23.));

/*****
* Application object: CUTTER_LOCATION_TRAJECTORY (#570)
* ITS_TYPE: #570, #571, #572, #549, #550 ['trajectory path']
* ITS_TECHNOLOGY: #570, #573, #1062
* ITS_PRIORITY: #570, #574, #575, #554, #555 ['required']
* ITS_ID: #570 ['WS 1 TP 2']
* BASICCURVE: #570, #576, #577, #578, #579
*/
#570=MACHINING_TOOLPATH('WS 1 TP 2', 'cutter location trajectory', '', '');
#571=ACTION_PROPERTY('trajectory type', 'cutter location trajectory', #570);
#572=ACTION_PROPERTY_REPRESENTATION('', 'cutter location trajectory', #571,
#549);
#573=MACHINING_TECHNOLOGY_RELATIONSHIP('', 'cutter location trajectory', #570,
#1062);
#574=ACTION_PROPERTY('priority', 'cutter location trajectory', #570);
#575=ACTION_PROPERTY_REPRESENTATION('', 'cutter location trajectory', #574,
#554);
#576=ACTION_PROPERTY('basic curve', 'cutter location trajectory', #570);
#577=ACTION_PROPERTY_REPRESENTATION('', 'cutter location trajectory', #576,
#578);
#578=REPRESENTATION('', (#579), #565);
#579=COMPOSITE_CURVE('composite curve for WS 1 TP 2', (#580, #584, #592), .F.);
#580=COMPOSITE_CURVE_SEGMENT(.CONTINUOUS., .T., #581);
#581=POLYLINE('basic curve for WS 1 TP 2', (#569, #582, #583));
#582=CARTESIAN_POINT('', (76.6078, 112.6997, 20.));
#583=CARTESIAN_POINT('', (93.5102, 109.6997, 20.));

```

```

#584=COMPOSITE_CURVE_SEGMENT(.CONTINUOUS.,.T.,#585);
#585=TRIMMED_CURVE('Arc for in WS 1 TP 2',#586,(#583),(#591),.F.,.CARTESIAN.);
#586=CIRCLE('Circle for in WS 1 TP 2',#587,19.8938);
#587=AXIS2_PLACEMENT_3D('Arc placement for in WS 1 TP 2',#588,#589,#590);
#588=CARTESIAN_POINT('Arc centre for in WS 1 TP 2',(90.0336,90.112,20.));
#589=DIRECTION('Z direction',(0.,0.,1.));
#590=DIRECTION('X direction',(1.,0.,0.));
#591=CARTESIAN_POINT('Arc end for in WS 1 TP 2',(102.0069,105.9992,20.));
#592=COMPOSITE_CURVE_SEGMENT(.DISCONTINUOUS.,.T.,#593);
#593=TRIMMED_CURVE('Arc for in WS 1 TP 2',#594,(#591),(#597),.F.,.CARTESIAN.);
#594=CIRCLE('Circle for in WS 1 TP 2',#595,20.0085);
#595=AXIS2_PLACEMENT_3D('Arc placement for in WS 1 TP 2',#596,#589,#590);
#596=CARTESIAN_POINT('Arc centre for in WS 1 TP 2',(89.9986,89.9948,20.));
#597=CARTESIAN_POINT('Arc end for in WS 1 TP 2',(109.6997,93.4889,20.));

/*****
* Application object: CUTTER_LOCATION_TRAJECTORY (#598)
* ITS_TYPE: #598, #599, #600, #549, #550 ['trajectory path']
* ITS_TECHNOLOGY: #598, #601, #1062
* ITS_PRIORITY: #598, #602, #603, #554, #555 ['required']
* RAPID_SPEED: #598, #604, #605, #606, #607 ['true']
* ITS_ID: #598 ['WS 1 TP 3']
* BASICCURVE: #598, #608, #609, #610, #611
*/
#598=MACHINING_TOOLPATH('WS 1 TP 3','cutter location trajectory','','');
#599=ACTION_PROPERTY('trajectory type','cutter location trajectory',#598);
#600=ACTION_PROPERTY_REPRESENTATION('','cutter location trajectory',#599,
#549);
#601=MACHINING_TECHNOLOGY_RELATIONSHIP('','cutter location trajectory',#598,
#1062);
#602=ACTION_PROPERTY('priority','cutter location trajectory',#598);
#603=ACTION_PROPERTY_REPRESENTATION('','cutter location trajectory',#602,
#554);
#604=ACTION_PROPERTY('speed profile','rapid',#598);
#605=ACTION_PROPERTY_REPRESENTATION('','rapid',#604,#606);
#606=MACHINING_TOOLPATH_SPEED_PROFILE_REPRESENTATION('',( #607),#564);
#607=DESCRIPTIVE_REPRESENTATION_ITEM('','rapid');
#608=ACTION_PROPERTY('basic curve','cutter location trajectory',#598);
#609=ACTION_PROPERTY_REPRESENTATION('','cutter location trajectory',#608,
#610);
#610=REPRESENTATION('',( #611),#565);
#611=POLYLINE('basic curve for WS 1 TP 3',( #597,#612,#613,#614,#615,#616));
#612=CARTESIAN_POINT('',(112.6997,76.5738,20.));
#613=CARTESIAN_POINT('',(112.6997,76.5738,23.));
#614=CARTESIAN_POINT('',(112.6997,76.5738,28.));
#615=CARTESIAN_POINT('',(-12.6979,98.9837,28.));
#616=CARTESIAN_POINT('',(-12.6979,98.9837,23.));

/*****
* Application object: CUTTER_LOCATION_TRAJECTORY (#617)
* ITS_TYPE: #617, #618, #619, #549, #550 ['trajectory path']
* ITS_TECHNOLOGY: #617, #620, #1062
* ITS_PRIORITY: #617, #621, #622, #554, #555 ['required']
* ITS_ID: #617 ['WS 1 TP 4']

```



```

* BASICCURVE: #617, #623, #624, #625, #626
*/
#617=MACHINING_TOOLPATH('WS 1 TP 4','cutter location trajectory','','');
#618=ACTION_PROPERTY('trajectory type','cutter location trajectory',#617);
#619=ACTION_PROPERTY_REPRESENTATION('','cutter location trajectory',#618,
#549);
#620=MACHINING_TECHNOLOGY_RELATIONSHIP('','cutter location trajectory',#617,
#1062);
#621=ACTION_PROPERTY('priority','cutter location trajectory',#617);
#622=ACTION_PROPERTY_REPRESENTATION('','cutter location trajectory',#621,
#554);
#623=ACTION_PROPERTY('basic curve','cutter location trajectory',#617);
#624=ACTION_PROPERTY_REPRESENTATION('','cutter location trajectory',#623,
#625);
#625=REPRESENTATION('',( #626), #565);
#626=COMPOSITE_CURVE('composite curve for WS 1 TP 4', (#627, #631, #637, #643,
#649, #655, #660, #666), .F.);
#627=COMPOSITE_CURVE_SEGMENT(.CONTINUOUS., .T., #628);
#628=POLYLINE('basic curve for WS 1 TP 4', (#616, #629, #630));
#629=CARTESIAN_POINT('', (-12.6979, 98.9837, 20.));
#630=CARTESIAN_POINT('', (-9.5374, 101.5877, 20.));
#631=COMPOSITE_CURVE_SEGMENT(.CONTINUOUS., .T., #632);
#632=TRIMMED_CURVE('Arc for in WS 1 TP 4', #633, (#630), (#636), .F., .CARTESIAN.);
#633=CIRCLE('Circle for in WS 1 TP 4', #634, 14.9775);
#634=AXIS2_PLACEMENT_3D('Arc placement for in WS 1 TP 4', #635, #589, #590);
#635=CARTESIAN_POINT('Arc centre for in WS 1 TP 4', (-0.0136, 90.028, 20.));
#636=CARTESIAN_POINT('Arc end for in WS 1 TP 4', (-1.9146, 104.8844, 20.));
#637=COMPOSITE_CURVE_SEGMENT(.CONTINUOUS., .T., #638);
#638=POLYLINE('basic curve for WS 1 TP 4', (#636, #639, #640, #641, #642));
#639=CARTESIAN_POINT('', (-1.7697, 104.9029, 20.));
#640=CARTESIAN_POINT('', (-0.3611, 105.0001, 20.));
#641=CARTESIAN_POINT('', (90.4542, 105.0001, 20.));
#642=CARTESIAN_POINT('', (90.539, 104.9972, 20.));
#643=COMPOSITE_CURVE_SEGMENT(.CONTINUOUS., .T., #644);
#644=TRIMMED_CURVE('Arc for in WS 1 TP 4', #645, (#642), (#648), .F., .CARTESIAN.);
#645=CIRCLE('Circle for in WS 1 TP 4', #646, 14.8938);
#646=AXIS2_PLACEMENT_3D('Arc placement for in WS 1 TP 4', #647, #589, #590);
#647=CARTESIAN_POINT('Arc centre for in WS 1 TP 4', (90.0336, 90.112, 20.));
#648=CARTESIAN_POINT('Arc end for in WS 1 TP 4', (99.0019, 102.003, 20.));
#649=COMPOSITE_CURVE_SEGMENT(.CONTINUOUS., .T., #650);
#650=TRIMMED_CURVE('Arc for in WS 1 TP 4', #651, (#648), (#654), .F., .CARTESIAN.);
#651=CIRCLE('Circle for in WS 1 TP 4', #652, 15.0085);
#652=AXIS2_PLACEMENT_3D('Arc placement for in WS 1 TP 4', #653, #589, #590);
#653=CARTESIAN_POINT('Arc centre for in WS 1 TP 4', (89.9986, 89.9948, 20.));
#654=CARTESIAN_POINT('Arc end for in WS 1 TP 4', (104.9966, 90.5564, 20.));
#655=COMPOSITE_CURVE_SEGMENT(.CONTINUOUS., .T., #656);
#656=POLYLINE('basic curve for WS 1 TP 4', (#654, #657, #658, #659));
#657=CARTESIAN_POINT('', (105.0001, 90.4629, 20.));
#658=CARTESIAN_POINT('', (105.0001, -0.2221, 20.));
#659=CARTESIAN_POINT('', (104.9997, -0.2552, 20.));
#660=COMPOSITE_CURVE_SEGMENT(.CONTINUOUS., .T., #661);
#661=TRIMMED_CURVE('Arc for in WS 1 TP 4', #662, (#659), (#665), .F., .CARTESIAN.);
#662=CIRCLE('Circle for in WS 1 TP 4', #663, 14.8411);
#663=AXIS2_PLACEMENT_3D('Arc placement for in WS 1 TP 4', #664, #589, #590);

```

```
#664=CARTESIAN_POINT('Arc centre for in WS 1 TP 4', (90.1599,-0.0584,20.));
#665=CARTESIAN_POINT('Arc end for in WS 1 TP 4', (102.0037,-9.0016,20.));
#666=COMPOSITE_CURVE_SEGMENT(.DISCONTINUOUS.,.T.,#667);
#667=TRIMMED_CURVE('Arc for in WS 1 TP 4',#668, (#665), (#671), .F., .CARTESIAN.);
#668=CIRCLE('Circle for in WS 1 TP 4',#669,14.9146);
#669=AXIS2_PLACEMENT_3D('Arc placement for in WS 1 TP 4',#670,#589,#590);
#670=CARTESIAN_POINT('Arc centre for in WS 1 TP 4', (90.0613,-0.0673,20.));
#671=CARTESIAN_POINT('Arc end for in WS 1 TP 4', (101.5829,-9.5381,20.));
```

```
/******
```

```
* Application object: CUTTER_LOCATION_TRAJECTORY (#672)
* ITS_TYPE: #672, #673, #674, #549, #550 ['trajectory path']
* ITS_TECHNOLOGY: #672, #675, #1062
* ITS_PRIORITY: #672, #676, #677, #554, #555 ['required']
* RAPID_SPEED: #672, #678, #679, #680, #681 ['true']
* ITS_ID: #672 ['WS 1 TP 5']
* BASICCURVE: #672, #682, #683, #684, #685
*/
```

```
#672=MACHINING_TOOLPATH('WS 1 TP 5','cutter location trajectory','','');
#673=ACTION_PROPERTY('trajectory type','cutter location trajectory',#672);
#674=ACTION_PROPERTY_REPRESENTATION('','cutter location trajectory',#673,
#549);
#675=MACHINING_TECHNOLOGY_RELATIONSHIP('','cutter location trajectory',#672,
#1062);
#676=ACTION_PROPERTY('priority','cutter location trajectory',#672);
#677=ACTION_PROPERTY_REPRESENTATION('','cutter location trajectory',#676,
#554);
#678=ACTION_PROPERTY('speed profile','rapid',#672);
#679=ACTION_PROPERTY_REPRESENTATION('','rapid',#678,#680);
#680=MACHINING_TOOLPATH_SPEED_PROFILE_REPRESENTATION('',( #681),#564);
#681=DESCRIPTIVE_REPRESENTATION_ITEM('','rapid');
#682=ACTION_PROPERTY('basic curve','cutter location trajectory',#672);
#683=ACTION_PROPERTY_REPRESENTATION('','cutter location trajectory',#682,
#684);
#684=REPRESENTATION('',( #685),#565);
#685=POLYLINE('basic curve for WS 1 TP 5', (#671,#686,#687,#688,#689,#690));
#686=CARTESIAN_POINT('',(98.9855,-12.6979,20.));
#687=CARTESIAN_POINT('',(98.9855,-12.6979,23.));
#688=CARTESIAN_POINT('',(98.9855,-12.6979,28.));
#689=CARTESIAN_POINT('',(-12.9971,88.1,28.));
#690=CARTESIAN_POINT('',(-12.9971,88.1,23.));
```

```
/******
```

```
* Application object: CUTTER_LOCATION_TRAJECTORY (#691)
* ITS_TYPE: #691, #692, #693, #549, #550 ['trajectory path']
* ITS_TECHNOLOGY: #691, #694, #1062
* ITS_PRIORITY: #691, #695, #696, #554, #555 ['required']
* ITS_ID: #691 ['WS 1 TP 6']
* BASICCURVE: #691, #697, #698, #699, #700
*/
```

```
#691=MACHINING_TOOLPATH('WS 1 TP 6','cutter location trajectory','','');
#692=ACTION_PROPERTY('trajectory type','cutter location trajectory',#691);
#693=ACTION_PROPERTY_REPRESENTATION('','cutter location trajectory',#692,
#549);
```

```

#694=MACHINING_TECHNOLOGY_RELATIONSHIP('', 'cutter location trajectory', #691,
#1062);
#695=ACTION_PROPERTY('priority', 'cutter location trajectory', #691);
#696=ACTION_PROPERTY_REPRESENTATION('', 'cutter location trajectory', #695,
#554);
#697=ACTION_PROPERTY('basic curve', 'cutter location trajectory', #691);
#698=ACTION_PROPERTY_REPRESENTATION('', 'cutter location trajectory', #697,
#699);
#699=REPRESENTATION('', (#700), #565);
#700=COMPOSITE_CURVE('composite curve for WS 1 TP 6', (#701, #704, #710, #716,
#722, #726, #732, #738, #741, #747, #753, #759), .F.);
#701=COMPOSITE_CURVE_SEGMENT(.CONTINUOUS., .T., #702);
#702=POLYLINE('basic curve for WS 1 TP 6', (#690, #703));
#703=CARTESIAN_POINT('', (-12.9971, 88.1, 20.));
#704=COMPOSITE_CURVE_SEGMENT(.CONTINUOUS., .T., #705);
#705=TRIMMED_CURVE('Arc for in WS 1 TP 6', #706, (#703), (#709), .T., .CARTESIAN.);
#706=CIRCLE('Circle for in WS 1 TP 6', #707, 7.);
#707=AXIS2_PLACEMENT_3D('Arc placement for in WS 1 TP 6', #708, #589, #590);
#708=CARTESIAN_POINT('Arc centre for in WS 1 TP 6', (-16.4813, 94.1712, 20.));
#709=CARTESIAN_POINT('Arc end for in WS 1 TP 6', (-9.6979, 92.4432, 20.));
#710=COMPOSITE_CURVE_SEGMENT(.CONTINUOUS., .T., #711);
#711=TRIMMED_CURVE('Arc for in WS 1 TP 6', #712, (#709), (#715), .F., .CARTESIAN.);
#712=CIRCLE('Circle for in WS 1 TP 6', #713, 10.2831);
#713=AXIS2_PLACEMENT_3D('Arc placement for in WS 1 TP 6', #714, #589, #590);
#714=CARTESIAN_POINT('Arc centre for in WS 1 TP 6', (0.2669, 89.9048, 20.));
#715=CARTESIAN_POINT('Arc end for in WS 1 TP 6', (-8.8119, 94.7336, 20.));
#716=COMPOSITE_CURVE_SEGMENT(.CONTINUOUS., .T., #717);
#717=TRIMMED_CURVE('Arc for in WS 1 TP 6', #718, (#715), (#721), .F., .CARTESIAN.);
#718=CIRCLE('Circle for in WS 1 TP 6', #719, 9.9775);
#719=AXIS2_PLACEMENT_3D('Arc placement for in WS 1 TP 6', #720, #589, #590);
#720=CARTESIAN_POINT('Arc centre for in WS 1 TP 6', (-0.0136, 90.028, 20.));
#721=CARTESIAN_POINT('Arc end for in WS 1 TP 6', (-1.28, 99.9248, 20.));
#722=COMPOSITE_CURVE_SEGMENT(.CONTINUOUS., .T., #723);
#723=POLYLINE('basic curve for WS 1 TP 6', (#721, #724, #725));
#724=CARTESIAN_POINT('', (-0.1889, 100.0001, 20.));
#725=CARTESIAN_POINT('', (90.3693, 100.0001, 20.));
#726=COMPOSITE_CURVE_SEGMENT(.CONTINUOUS., .T., #727);
#727=TRIMMED_CURVE('Arc for in WS 1 TP 6', #728, (#725), (#731), .F., .CARTESIAN.);
#728=CIRCLE('Circle for in WS 1 TP 6', #729, 9.8938);
#729=AXIS2_PLACEMENT_3D('Arc placement for in WS 1 TP 6', #730, #589, #590);
#730=CARTESIAN_POINT('Arc centre for in WS 1 TP 6', (90.0336, 90.112, 20.));
#731=CARTESIAN_POINT('Arc end for in WS 1 TP 6', (95.9968, 98.0068, 20.));
#732=COMPOSITE_CURVE_SEGMENT(.CONTINUOUS., .T., #733);
#733=TRIMMED_CURVE('Arc for in WS 1 TP 6', #734, (#731), (#737), .F., .CARTESIAN.);
#734=CIRCLE('Circle for in WS 1 TP 6', #735, 10.0085);
#735=AXIS2_PLACEMENT_3D('Arc placement for in WS 1 TP 6', #736, #589, #590);
#736=CARTESIAN_POINT('Arc centre for in WS 1 TP 6', (89.9986, 89.9948, 20.));
#737=CARTESIAN_POINT('Arc end for in WS 1 TP 6', (100.0001, 90.3693, 20.));
#738=COMPOSITE_CURVE_SEGMENT(.CONTINUOUS., .T., #739);
#739=POLYLINE('basic curve for WS 1 TP 6', (#737, #740));
#740=CARTESIAN_POINT('', (100.0001, -0.1889, 20.));
#741=COMPOSITE_CURVE_SEGMENT(.CONTINUOUS., .T., #742);
#742=TRIMMED_CURVE('Arc for in WS 1 TP 6', #743, (#740), (#746), .F., .CARTESIAN.);
#743=CIRCLE('Circle for in WS 1 TP 6', #744, 9.8411);

```

```

#744=AXIS2_PLACEMENT_3D('Arc placement for in WS 1 TP 6',#745,#589,#590);
#745=CARTESIAN_POINT('Arc centre for in WS 1 TP 6',(90.1599,-0.0584,20.));
#746=CARTESIAN_POINT('Arc end for in WS 1 TP 6',(98.0068,-5.9975,20.));
#747=COMPOSITE_CURVE_SEGMENT(.CONTINUOUS.,.T.,#748);
#748=TRIMMED_CURVE('Arc for in WS 1 TP 6',#749,(#746),(#752),.F.,.CARTESIAN.);
#749=CIRCLE('Circle for in WS 1 TP 6',#750,9.9146);
#750=AXIS2_PLACEMENT_3D('Arc placement for in WS 1 TP 6',#751,#589,#590);
#751=CARTESIAN_POINT('Arc centre for in WS 1 TP 6',(90.0613,-0.0673,20.));
#752=CARTESIAN_POINT('Arc end for in WS 1 TP 6',(94.7336,-8.8119,20.));
#753=COMPOSITE_CURVE_SEGMENT(.CONTINUOUS.,.T.,#754);
#754=TRIMMED_CURVE('Arc for in WS 1 TP 6',#755,(#752),(#758),.F.,.CARTESIAN.);
#755=CIRCLE('Circle for in WS 1 TP 6',#756,9.6195);
#756=AXIS2_PLACEMENT_3D('Arc placement for in WS 1 TP 6',#757,#589,#590);
#757=CARTESIAN_POINT('Arc centre for in WS 1 TP 6',(90.1227,-0.3694,20.));
#758=CARTESIAN_POINT('Arc end for in WS 1 TP 6',(92.4709,-9.6979,20.));
#759=COMPOSITE_CURVE_SEGMENT(.DISCONTINUOUS.,.T.,#760);
#760=TRIMMED_CURVE('Arc for in WS 1 TP 6',#761,(#758),(#764),.T.,.CARTESIAN.);
#761=CIRCLE('Circle for in WS 1 TP 6',#762,7.);
#762=AXIS2_PLACEMENT_3D('Arc placement for in WS 1 TP 6',#763,#589,#590);
#763=CARTESIAN_POINT('Arc centre for in WS 1 TP 6',(94.1797,-16.4862,20.));
#764=CARTESIAN_POINT('Arc end for in WS 1 TP 6',(87.6325,-14.0095,20.));

/*****
* Application object: CUTTER_LOCATION_TRAJECTORY (#765)
* ITS_TYPE: #765, #766, #767, #549, #550 ['trajectory path']
* ITS_TECHNOLOGY: #765, #768, #1062
* ITS_PRIORITY: #765, #769, #770, #554, #555 ['required']
* RAPID_SPEED: #765, #771, #772, #773, #774 ['true']
* ITS_ID: #765 ['WS 1 TP 7']
* BASICCURVE: #765, #775, #776, #777, #778
*/
#765=MACHINING_TOOLPATH('WS 1 TP 7','cutter location trajectory','','');
#766=ACTION_PROPERTY('trajectory type','cutter location trajectory',#765);
#767=ACTION_PROPERTY_REPRESENTATION('','cutter location trajectory',#766,
#549);
#768=MACHINING_TECHNOLOGY_RELATIONSHIP('','cutter location trajectory',#765,
#1062);
#769=ACTION_PROPERTY('priority','cutter location trajectory',#765);
#770=ACTION_PROPERTY_REPRESENTATION('','cutter location trajectory',#769,
#554);
#771=ACTION_PROPERTY('speed profile','rapid',#765);
#772=ACTION_PROPERTY_REPRESENTATION('','rapid',#771,#773);
#773=MACHINING_TOOLPATH_SPEED_PROFILE_REPRESENTATION('',( #774 ),#564);
#774=DESCRIPTIVE_REPRESENTATION_ITEM('','rapid');
#775=ACTION_PROPERTY('basic curve','cutter location trajectory',#765);
#776=ACTION_PROPERTY_REPRESENTATION('','cutter location trajectory',#775,
#777);
#777=REPRESENTATION('',( #778 ),#565);
#778=POLYLINE('basic curve for WS 1 TP 7',( #764 ,#779 ,#780 ,#781 ,#782 ,#783 ));
#779=CARTESIAN_POINT('',(87.6325,-14.0095,23.));
#780=CARTESIAN_POINT('',(87.6325,-14.0095,31.));
#781=CARTESIAN_POINT('',(76.7996,112.6997,31.));
#782=CARTESIAN_POINT('',(76.7996,112.6997,23.));
#783=CARTESIAN_POINT('',(76.7996,112.6997,18.));

```

```

/*****
* Application object: CUTTER_LOCATION_TRAJECTORY (#784)
* ITS_TYPE: #784, #785, #786, #549, #550 ['trajectory path']
* ITS_TECHNOLOGY: #784, #787, #1062
* ITS_PRIORITY: #784, #788, #789, #554, #555 ['required']
* ITS_ID: #784 ['WS 1 TP 8']
* BASICCURVE: #784, #790, #791, #792, #793
*/
#784=MACHINING_TOOLPATH('WS 1 TP 8','cutter location trajectory','','');
#785=ACTION_PROPERTY('trajectory type','cutter location trajectory',#784);
#786=ACTION_PROPERTY_REPRESENTATION('','cutter location trajectory',#785,
#549);
#787=MACHINING_TECHNOLOGY_RELATIONSHIP('','cutter location trajectory',#784,
#1062);
#788=ACTION_PROPERTY('priority','cutter location trajectory',#784);
#789=ACTION_PROPERTY_REPRESENTATION('','cutter location trajectory',#788,
#554);
#790=ACTION_PROPERTY('basic curve','cutter location trajectory',#784);
#791=ACTION_PROPERTY_REPRESENTATION('','cutter location trajectory',#790,
#792);
#792=REPRESENTATION('',(793),#565);
#793=COMPOSITE_CURVE('composite curve for WS 1 TP 8',(794,#798,#804,#808,
#814,#818),.F.);
#794=COMPOSITE_CURVE_SEGMENT(.CONTINUOUS.,.T.,#795);
#795=POLYLINE('basic curve for WS 1 TP 8',(783,#796,#797));
#796=CARTESIAN_POINT('',(76.7996,112.6997,15.));
#797=CARTESIAN_POINT('',(93.5151,109.6997,15.));
#798=COMPOSITE_CURVE_SEGMENT(.CONTINUOUS.,.T.,#799);
#799=TRIMMED_CURVE('Arc for in WS 1 TP 8',#800,(797),(803),.F.,.CARTESIAN.);
#800=CIRCLE('Circle for in WS 1 TP 8',#801,20.0969);
#801=AXIS2_PLACEMENT_3D('Arc placement for in WS 1 TP 8',#802,#589,#590);
#802=CARTESIAN_POINT('Arc centre for in WS 1 TP 8',(89.9649,89.9188,15.));
#803=CARTESIAN_POINT('Arc end for in WS 1 TP 8',(101.6281,106.2851,15.));
#804=COMPOSITE_CURVE_SEGMENT(.CONTINUOUS.,.T.,#805);
#805=POLYLINE('basic curve for WS 1 TP 8',(803,#806,#807));
#806=CARTESIAN_POINT('',(101.6318,106.2824,15.));
#807=CARTESIAN_POINT('',(101.6356,106.2798,15.));
#808=COMPOSITE_CURVE_SEGMENT(.CONTINUOUS.,.T.,#809);
#809=TRIMMED_CURVE('Arc for in WS 1 TP 8',#810,(807),(813),.F.,.CARTESIAN.);
#810=CIRCLE('Circle for in WS 1 TP 8',#811,19.9541);
#811=AXIS2_PLACEMENT_3D('Arc placement for in WS 1 TP 8',#812,#589,#590);
#812=CARTESIAN_POINT('Arc centre for in WS 1 TP 8',(90.0404,90.0404,15.));
#813=CARTESIAN_POINT('Arc end for in WS 1 TP 8',(107.6374,99.4484,15.));
#814=COMPOSITE_CURVE_SEGMENT(.CONTINUOUS.,.T.,#815);
#815=POLYLINE('basic curve for WS 1 TP 8',(813,#816,#817));
#816=CARTESIAN_POINT('',(107.6398,99.4439,15.));
#817=CARTESIAN_POINT('',(107.6422,99.4394,15.));
#818=COMPOSITE_CURVE_SEGMENT(.DISCONTINUOUS.,.T.,#819);
#819=TRIMMED_CURVE('Arc for in WS 1 TP 8',#820,(817),(823),.F.,.CARTESIAN.);
#820=CIRCLE('Circle for in WS 1 TP 8',#821,20.1824);
#821=AXIS2_PLACEMENT_3D('Arc placement for in WS 1 TP 8',#822,#589,#590);
#822=CARTESIAN_POINT('Arc centre for in WS 1 TP 8',(89.8342,89.9419,15.));
#823=CARTESIAN_POINT('Arc end for in WS 1 TP 8',(109.6997,93.5045,15.));

```

```

/*****
* Application object: CUTTER_LOCATION_TRAJECTORY (#824)
* ITS_TYPE: #824, #825, #826, #549, #550 ['trajectory path']
* ITS_TECHNOLOGY: #824, #827, #1062
* ITS_PRIORITY: #824, #828, #829, #554, #555 ['required']
* RAPID_SPEED: #824, #830, #831, #832, #833 ['true']
* ITS_ID: #824 ['WS 1 TP 9']
* BASICCURVE: #824, #834, #835, #836, #837
*/
#824=MACHINING_TOOLPATH('WS 1 TP 9','cutter location trajectory','','');
#825=ACTION_PROPERTY('trajectory type','cutter location trajectory',#824);
#826=ACTION_PROPERTY_REPRESENTATION('','cutter location trajectory',#825,
#549);
#827=MACHINING_TECHNOLOGY_RELATIONSHIP('','cutter location trajectory',#824,
#1062);
#828=ACTION_PROPERTY('priority','cutter location trajectory',#824);
#829=ACTION_PROPERTY_REPRESENTATION('','cutter location trajectory',#828,
#554);
#830=ACTION_PROPERTY('speed profile','rapid',#824);
#831=ACTION_PROPERTY_REPRESENTATION('','rapid',#830,#832);
#832=MACHINING_TOOLPATH_SPEED_PROFILE_REPRESENTATION('',(833),#564);
#833=DESCRIPTIVE_REPRESENTATION_ITEM('','rapid');
#834=ACTION_PROPERTY('basic curve','cutter location trajectory',#824);
#835=ACTION_PROPERTY_REPRESENTATION('','cutter location trajectory',#834,
#836);
#836=REPRESENTATION('',(837),#565);
#837=POLYLINE('basic curve for WS 1 TP 9',(823,#838,#839,#840,#841,#842,
#843));
#838=CARTESIAN_POINT('',(112.6997,76.7764,15.));
#839=CARTESIAN_POINT('',(112.6997,76.7764,18.));
#840=CARTESIAN_POINT('',(112.6997,76.7764,31.));
#841=CARTESIAN_POINT('',(-12.6979,98.9932,31.));
#842=CARTESIAN_POINT('',(-12.6979,98.9932,23.));
#843=CARTESIAN_POINT('',(-12.6979,98.9932,18.));

/*****
* Application object: CUTTER_LOCATION_TRAJECTORY (#844)
* ITS_TYPE: #844, #845, #846, #549, #550 ['trajectory path']
* ITS_TECHNOLOGY: #844, #847, #1062
* ITS_PRIORITY: #844, #848, #849, #554, #555 ['required']
* ITS_ID: #844 ['WS 1 TP 10']
* BASICCURVE: #844, #850, #851, #852, #853
*/
#844=MACHINING_TOOLPATH('WS 1 TP 10','cutter location trajectory','','');
#845=ACTION_PROPERTY('trajectory type','cutter location trajectory',#844);
#846=ACTION_PROPERTY_REPRESENTATION('','cutter location trajectory',#845,
#549);
#847=MACHINING_TECHNOLOGY_RELATIONSHIP('','cutter location trajectory',#844,
#1062);
#848=ACTION_PROPERTY('priority','cutter location trajectory',#844);
#849=ACTION_PROPERTY_REPRESENTATION('','cutter location trajectory',#848,
#554);
#850=ACTION_PROPERTY('basic curve','cutter location trajectory',#844);

```

```

#851=ACTION_PROPERTY_REPRESENTATION('', 'cutter location trajectory', #850,
#852);
#852=REPRESENTATION('', (#853), #565);
#853=COMPOSITE_CURVE('composite curve for WS 1 TP 10', (#854, #858, #864, #870,
#876, #880, #886, #890, #896, #901, #907), .F.);
#854=COMPOSITE_CURVE_SEGMENT(.CONTINUOUS., .T., #855);
#855=POLYLINE('basic curve for WS 1 TP 10', (#843, #856, #857));
#856=CARTESIAN_POINT('', (-12.6979, 98.9932, 15.));
#857=CARTESIAN_POINT('', (-9.5364, 101.5958, 15.));
#858=COMPOSITE_CURVE_SEGMENT(.CONTINUOUS., .T., #859);
#859=TRIMMED_CURVE('Arc for in WS 1 TP
10', #860, (#857), (#863), .F., .CARTESIAN.);
#860=CIRCLE('Circle for in WS 1 TP 10', #861, 14.9952);
#861=AXIS2_PLACEMENT_3D('Arc placement for in WS 1 TP 10', #862, #589, #590);
#862=CARTESIAN_POINT('Arc centre for in WS 1 TP 10', (-0.0061, 90.0187, 15.));
#863=CARTESIAN_POINT('Arc end for in WS 1 TP 10', (-1.9172, 104.8916, 15.));
#864=COMPOSITE_CURVE_SEGMENT(.CONTINUOUS., .T., #865);
#865=POLYLINE('basic curve for WS 1 TP 10', (#863, #866, #867, #868, #869));
#866=CARTESIAN_POINT('', (-1.771, 104.9104, 15.));
#867=CARTESIAN_POINT('', (-0.3611, 105.0076, 15.));
#868=CARTESIAN_POINT('', (90.4695, 105.0076, 15.));
#869=CARTESIAN_POINT('', (90.5696, 105.0036, 15.));
#870=COMPOSITE_CURVE_SEGMENT(.CONTINUOUS., .T., #871);
#871=TRIMMED_CURVE('Arc for in WS 1 TP
10', #872, (#869), (#875), .F., .CARTESIAN.);
#872=CIRCLE('Circle for in WS 1 TP 10', #873, 15.0969);
#873=AXIS2_PLACEMENT_3D('Arc placement for in WS 1 TP 10', #874, #589, #590);
#874=CARTESIAN_POINT('Arc centre for in WS 1 TP 10', (89.9649, 89.9188, 15.));
#875=CARTESIAN_POINT('Arc end for in WS 1 TP 10', (98.7264, 102.2132, 15.));
#876=COMPOSITE_CURVE_SEGMENT(.CONTINUOUS., .T., #877);
#877=POLYLINE('basic curve for WS 1 TP 10', (#875, #878, #879));
#878=CARTESIAN_POINT('', (98.7282, 102.2119, 15.));
#879=CARTESIAN_POINT('', (98.7301, 102.2106, 15.));
#880=COMPOSITE_CURVE_SEGMENT(.CONTINUOUS., .T., #881);
#881=TRIMMED_CURVE('Arc for in WS 1 TP
10', #882, (#879), (#885), .F., .CARTESIAN.);
#882=CIRCLE('Circle for in WS 1 TP 10', #883, 14.9541);
#883=AXIS2_PLACEMENT_3D('Arc placement for in WS 1 TP 10', #884, #589, #590);
#884=CARTESIAN_POINT('Arc centre for in WS 1 TP 10', (90.0404, 90.0404, 15.));
#885=CARTESIAN_POINT('Arc end for in WS 1 TP 10', (103.228, 97.091, 15.));
#886=COMPOSITE_CURVE_SEGMENT(.CONTINUOUS., .T., #887);
#887=POLYLINE('basic curve for WS 1 TP 10', (#885, #888, #889));
#888=CARTESIAN_POINT('', (103.2292, 97.0888, 15.));
#889=CARTESIAN_POINT('', (103.2304, 97.0865, 15.));
#890=COMPOSITE_CURVE_SEGMENT(.CONTINUOUS., .T., #891);
#891=TRIMMED_CURVE('Arc for in WS 1 TP
10', #892, (#889), (#895), .F., .CARTESIAN.);
#892=CIRCLE('Circle for in WS 1 TP 10', #893, 15.1824);
#893=AXIS2_PLACEMENT_3D('Arc placement for in WS 1 TP 10', #894, #589, #590);
#894=CARTESIAN_POINT('Arc centre for in WS 1 TP 10', (89.8342, 89.9419, 15.));
#895=CARTESIAN_POINT('Arc end for in WS 1 TP 10', (105.0032, 90.5792, 15.));
#896=COMPOSITE_CURVE_SEGMENT(.CONTINUOUS., .T., #897);
#897=POLYLINE('basic curve for WS 1 TP 10', (#895, #898, #899, #900));
#898=CARTESIAN_POINT('', (105.0076, 90.4743, 15.));

```

```

#899=CARTESIAN_POINT('',(105.0076,-0.222,15.));
#900=CARTESIAN_POINT('',(105.0072,-0.255,15.));
#901=COMPOSITE_CURVE_SEGMENT(.CONTINUOUS.,.T.,#902);
#902=TRIMMED_CURVE('Arc for in WS 1 TP
10',#903,(#900),(#906),.F.,.CARTESIAN.);
#903=CIRCLE('Circle for in WS 1 TP 10',#904,14.8322);
#904=AXIS2_PLACEMENT_3D('Arc placement for in WS 1 TP 10',#905,#589,#590);
#905=CARTESIAN_POINT('Arc centre for in WS 1 TP 10',(90.1763,-0.059,15.));
#906=CARTESIAN_POINT('Arc end for in WS 1 TP 10',(101.9997,-9.0144,15.));
#907=COMPOSITE_CURVE_SEGMENT(.DISCONTINUOUS.,.T.,#908);
#908=TRIMMED_CURVE('Arc for in WS 1 TP
10',#909,(#906),(#912),.F.,.CARTESIAN.);
#909=CIRCLE('Circle for in WS 1 TP 10',#910,14.9841);
#910=AXIS2_PLACEMENT_3D('Arc placement for in WS 1 TP 10',#911,#589,#590);
#911=CARTESIAN_POINT('Arc centre for in WS 1 TP 10',(90.012,-0.0245,15.));
#912=CARTESIAN_POINT('Arc end for in WS 1 TP 10',(101.589,-9.5375,15.));

/*****
* Application object: CUTTER_LOCATION_TRAJECTORY (#913)
* ITS_TYPE: #913, #914, #915, #549, #550 ['trajectory path']
* ITS_TECHNOLOGY: #913, #916, #1062
* ITS_PRIORITY: #913, #917, #918, #554, #555 ['required']
* RAPID_SPEED: #913, #919, #920, #921, #922 ['true']
* ITS_ID: #913 ['WS 1 TP 11']
* BASICCURVE: #913, #923, #924, #925, #926
*/
#913=MACHINING_TOOLPATH('WS 1 TP 11','cutter location trajectory','',');
#914=ACTION_PROPERTY('trajectory type','cutter location trajectory',#913);
#915=ACTION_PROPERTY_REPRESENTATION('','cutter location trajectory',#914,
#549);
#916=MACHINING_TECHNOLOGY_RELATIONSHIP('','cutter location trajectory',#913,
#1062);
#917=ACTION_PROPERTY('priority','cutter location trajectory',#913);
#918=ACTION_PROPERTY_REPRESENTATION('','cutter location trajectory',#917,
#554);
#919=ACTION_PROPERTY('speed profile','rapid',#913);
#920=ACTION_PROPERTY_REPRESENTATION('','rapid',#919,#921);
#921=MACHINING_TOOLPATH_SPEED_PROFILE_REPRESENTATION('',(922),#564);
#922=DESCRIPTIVE_REPRESENTATION_ITEM('','rapid');
#923=ACTION_PROPERTY('basic curve','cutter location trajectory',#913);
#924=ACTION_PROPERTY_REPRESENTATION('','cutter location trajectory',#923,
#925);
#925=REPRESENTATION('',(926),#565);
#926=POLYLINE('basic curve for WS 1 TP 11',(912,#927,#928,#929,#930,#931,
#932));
#927=CARTESIAN_POINT('',(98.992,-12.6979,15.));
#928=CARTESIAN_POINT('',(98.992,-12.6979,18.));
#929=CARTESIAN_POINT('',(98.992,-12.6979,31.));
#930=CARTESIAN_POINT('',(-12.9934,87.8423,31.));
#931=CARTESIAN_POINT('',(-12.9934,87.8423,23.));
#932=CARTESIAN_POINT('',(-12.9934,87.8423,18.));

/*****
* Application object: CUTTER_LOCATION_TRAJECTORY (#933)

```



```

* ITS_TYPE: #933, #934, #935, #549, #550 ['trajectory path']
* ITS_TECHNOLOGY: #933, #936, #1062
* ITS_PRIORITY: #933, #937, #938, #554, #555 ['required']
* ITS_ID: #933 ['WS 1 TP 12']
* BASICCURVE: #933, #939, #940, #941, #942
*/
#933=MACHINING_TOOLPATH('WS 1 TP 12','cutter location trajectory','','');
#934=ACTION_PROPERTY('trajectory type','cutter location trajectory',#933);
#935=ACTION_PROPERTY_REPRESENTATION('','cutter location trajectory',#934,
#549);
#936=MACHINING_TECHNOLOGY_RELATIONSHIP('','cutter location trajectory',#933,
#1062);
#937=ACTION_PROPERTY('priority','cutter location trajectory',#933);
#938=ACTION_PROPERTY_REPRESENTATION('','cutter location trajectory',#937,
#554);
#939=ACTION_PROPERTY('basic curve','cutter location trajectory',#933);
#940=ACTION_PROPERTY_REPRESENTATION('','cutter location trajectory',#939,
#941);
#941=REPRESENTATION('',( #942 ), #565);
#942=COMPOSITE_CURVE('composite curve for WS 1 TP 12', (#943, #946, #952, #957,
#963, #967, #973, #979, #985, #988, #994, #1000), .F.);
#943=COMPOSITE_CURVE_SEGMENT(.CONTINUOUS., .T., #944);
#944=POLYLINE('basic curve for WS 1 TP 12', (#932, #945));
#945=CARTESIAN_POINT('', (-12.9934, 87.8423, 15.));
#946=COMPOSITE_CURVE_SEGMENT(.CONTINUOUS., .T., #947);
#947=TRIMMED_CURVE('Arc for in WS 1 TP
12', #948, (#945), (#951), .T., .CARTESIAN.);
#948=CIRCLE('Circle for in WS 1 TP 12', #949, 7.);
#949=AXIS2_PLACEMENT_3D('Arc placement for in WS 1 TP 12', #950, #589, #590);
#950=CARTESIAN_POINT('Arc centre for in WS 1 TP 12', (-16.5527, 93.8698, 15.));
#951=CARTESIAN_POINT('Arc end for in WS 1 TP 12', (-9.6979, 92.4515, 15.));
#952=COMPOSITE_CURVE_SEGMENT(.CONTINUOUS., .T., #953);
#953=POLYLINE('basic curve for WS 1 TP 12', (#951, #954, #955, #956));
#954=CARTESIAN_POINT('', (-9.6772, 92.5514, 15.));
#955=CARTESIAN_POINT('', (-9.316, 93.6425, 15.));
#956=CARTESIAN_POINT('', (-8.8194, 94.7336, 15.));
#957=COMPOSITE_CURVE_SEGMENT(.CONTINUOUS., .T., #958);
#958=TRIMMED_CURVE('Arc for in WS 1 TP
12', #959, (#956), (#962), .F., .CARTESIAN.);
#959=CIRCLE('Circle for in WS 1 TP 12', #960, 9.9952);
#960=AXIS2_PLACEMENT_3D('Arc placement for in WS 1 TP 12', #961, #589, #590);
#961=CARTESIAN_POINT('Arc centre for in WS 1 TP 12', (-0.0061, 90.0187, 15.));
#962=CARTESIAN_POINT('Arc end for in WS 1 TP 12', (-1.28, 99.9324, 15.));
#963=COMPOSITE_CURVE_SEGMENT(.CONTINUOUS., .T., #964);
#964=POLYLINE('basic curve for WS 1 TP 12', (#962, #965, #966));
#965=CARTESIAN_POINT('', (-0.1889, 100.0076, 15.));
#966=CARTESIAN_POINT('', (90.3693, 100.0076, 15.));
#967=COMPOSITE_CURVE_SEGMENT(.CONTINUOUS., .T., #968);
#968=TRIMMED_CURVE('Arc for in WS 1 TP
12', #969, (#966), (#972), .F., .CARTESIAN.);
#969=CIRCLE('Circle for in WS 1 TP 12', #970, 10.0969);
#970=AXIS2_PLACEMENT_3D('Arc placement for in WS 1 TP 12', #971, #589, #590);
#971=CARTESIAN_POINT('Arc centre for in WS 1 TP 12', (89.9649, 89.9188, 15.));
#972=CARTESIAN_POINT('Arc end for in WS 1 TP 12', (95.8246, 98.1414, 15.));

```

```

#973=COMPOSITE_CURVE_SEGMENT(.CONTINUOUS.,.T.,#974);
#974=TRIMMED_CURVE('Arc for in WS 1 TP
12',#975,(#972),(#978),.F.,.CARTESIAN.);
#975=CIRCLE('Circle for in WS 1 TP 12',#976,9.9541);
#976=AXIS2_PLACEMENT_3D('Arc placement for in WS 1 TP 12',#977,#589,#590);
#977=CARTESIAN_POINT('Arc centre for in WS 1 TP 12',(90.0404,90.0404,15.));
#978=CARTESIAN_POINT('Arc end for in WS 1 TP 12',(98.8187,94.7336,15.));
#979=COMPOSITE_CURVE_SEGMENT(.CONTINUOUS.,.T.,#980);
#980=TRIMMED_CURVE('Arc for in WS 1 TP
12',#981,(#978),(#984),.F.,.CARTESIAN.);
#981=CIRCLE('Circle for in WS 1 TP 12',#982,10.1824);
#982=AXIS2_PLACEMENT_3D('Arc placement for in WS 1 TP 12',#983,#589,#590);
#983=CARTESIAN_POINT('Arc centre for in WS 1 TP 12',(89.8342,89.9419,15.));
#984=CARTESIAN_POINT('Arc end for in WS 1 TP 12',(100.0076,90.3693,15.));
#985=COMPOSITE_CURVE_SEGMENT(.CONTINUOUS.,.T.,#986);
#986=POLYLINE('basic curve for WS 1 TP 12',(#984,#987));
#987=CARTESIAN_POINT('',(100.0076,-0.1889,15.));
#988=COMPOSITE_CURVE_SEGMENT(.CONTINUOUS.,.T.,#989);
#989=TRIMMED_CURVE('Arc for in WS 1 TP
12',#990,(#987),(#993),.F.,.CARTESIAN.);
#990=CIRCLE('Circle for in WS 1 TP 12',#991,9.8322);
#991=AXIS2_PLACEMENT_3D('Arc placement for in WS 1 TP 12',#992,#589,#590);
#992=CARTESIAN_POINT('Arc centre for in WS 1 TP 12',(90.1763,-0.059,15.));
#993=CARTESIAN_POINT('Arc end for in WS 1 TP 12',(98.0068,-6.005,15.));
#994=COMPOSITE_CURVE_SEGMENT(.CONTINUOUS.,.T.,#995);
#995=TRIMMED_CURVE('Arc for in WS 1 TP
12',#996,(#993),(#999),.F.,.CARTESIAN.);
#996=CIRCLE('Circle for in WS 1 TP 12',#997,9.9841);
#997=AXIS2_PLACEMENT_3D('Arc placement for in WS 1 TP 12',#998,#589,#590);
#998=CARTESIAN_POINT('Arc centre for in WS 1 TP 12',(90.012,-0.0245,15.));
#999=CARTESIAN_POINT('Arc end for in WS 1 TP 12',(92.4833,-9.6979,15.));
#1000=COMPOSITE_CURVE_SEGMENT(.DISCONTINUOUS.,.T.,#1001);
#1001=TRIMMED_CURVE('Arc for in WS 1 TP
12',#1002,(#999),(#1005),.T.,.CARTESIAN.);
#1002=CIRCLE('Circle for in WS 1 TP 12',#1003,7.);
#1003=AXIS2_PLACEMENT_3D('Arc placement for in WS 1 TP 12',#1004,#589,#590);
#1004=CARTESIAN_POINT('Arc centre for in WS 1 TP 12',(94.216,-16.4801,15.));
#1005=CARTESIAN_POINT('Arc end for in WS 1 TP 12',(87.6601,-14.0265,15.));

/*****
* Application object: DERIVED_UNIT (#1006)
*/
#1006=DERIVED_UNIT((#1007));
#1007=DERIVED_UNIT_ELEMENT(#1095,-1.);

/*****
* Application object: DERIVED_UNIT (#1008)
*/
#1008=DERIVED_UNIT((#1009,#1010));
#1009=DERIVED_UNIT_ELEMENT(#1071,1.);
#1010=DERIVED_UNIT_ELEMENT(#1095,-1.);

/*****
* Application object: FREEFORM_OPERATION (#1011)

```

```

* ITS_TOOLPATH [1]: #1011, #1012, #546
* ITS_TOOLPATH [2]: #1011, #1013, #570
* ITS_TOOLPATH [3]: #1011, #1014, #598
* ITS_TOOLPATH [4]: #1011, #1015, #617
* ITS_TOOLPATH [5]: #1011, #1016, #672
* ITS_TOOLPATH [6]: #1011, #1017, #691
* ITS_TOOLPATH [7]: #1011, #1018, #765
* ITS_TOOLPATH [8]: #1011, #1019, #784
* ITS_TOOLPATH [9]: #1011, #1020, #824
* ITS_TOOLPATH [10]: #1011, #1021, #844
* ITS_TOOLPATH [11]: #1011, #1022, #913
* ITS_TOOLPATH [12]: #1011, #1023, #933
* ITS_TECHNOLOGY: #1011, #1024, #1053
* ITS_MACHINE_FUNCTIONS: #1011, #1025, #1040
* ITS_TOOL: #1011, #1150
* ITS_ID: #1011 ['WS 1']
*/
#1011=FREEFORM_MILLING_OPERATION('WS 1','','','');
#1012=MACHINING_TOOLPATH_SEQUENCE_RELATIONSHIP('','',#1011,#546,1.);
#1013=MACHINING_TOOLPATH_SEQUENCE_RELATIONSHIP('','',#1011,#570,2.);
#1014=MACHINING_TOOLPATH_SEQUENCE_RELATIONSHIP('','',#1011,#598,3.);
#1015=MACHINING_TOOLPATH_SEQUENCE_RELATIONSHIP('','',#1011,#617,4.);
#1016=MACHINING_TOOLPATH_SEQUENCE_RELATIONSHIP('','',#1011,#672,5.);
#1017=MACHINING_TOOLPATH_SEQUENCE_RELATIONSHIP('','',#1011,#691,6.);
#1018=MACHINING_TOOLPATH_SEQUENCE_RELATIONSHIP('','',#1011,#765,7.);
#1019=MACHINING_TOOLPATH_SEQUENCE_RELATIONSHIP('','',#1011,#784,8.);
#1020=MACHINING_TOOLPATH_SEQUENCE_RELATIONSHIP('','',#1011,#824,9.);
#1021=MACHINING_TOOLPATH_SEQUENCE_RELATIONSHIP('','',#1011,#844,10.);
#1022=MACHINING_TOOLPATH_SEQUENCE_RELATIONSHIP('','',#1011,#913,11.);
#1023=MACHINING_TOOLPATH_SEQUENCE_RELATIONSHIP('','',#1011,#933,12.);
#1024=MACHINING_TECHNOLOGY_RELATIONSHIP('','',#1011,#1053);
#1025=MACHINING_FUNCTIONS_RELATIONSHIP('','',#1011,#1040);

/*****
* Application object: GEOMETRIC_CONTEXT (#1026)
* LENGTH_UNIT: #1026, #1072 ['millimetre']
* PLANE_ANGLE_UNIT: #1026, #1078 ['degree']
* SOLID_ANGLE_UNIT: #1026, #1092 ['steradian']
* DIMENSIONS: #1026 [3]
*/
#1026= (
GEOMETRIC_REPRESENTATION_CONTEXT(3)
GLOBAL_UNCERTAINTY_ASSIGNED_CONTEXT((#1027))
GLOBAL_UNIT_ASSIGNED_CONTEXT((#1071,#1075,#1091))
REPRESENTATION_CONTEXT('simple_block_workpiece',
'TOP_LEVEL_ASSEMBLY_PART')
);
#1027=UNCERTAINTY_MEASURE_WITH_UNIT(LENGTH_MEASURE(2.E-005),#1071,
'DISTANCE_ACCURACY_VALUE','Maximum Tolerance applied to model');

/*****
* Application object: GEOMETRIC_CONTEXT (#1028)
* LENGTH_UNIT: #1028, #1074 ['millimetre']
* PLANE_ANGLE_UNIT: #1028, #1084 ['degree']

```

ISO 10303-238:2007(E)

```
* SOLID_ANGLE_UNIT: #1028, #1094 ['steradian']
* DIMENSIONS: #1028 [3]
*/
#1028=(
GEOMETRIC_REPRESENTATION_CONTEXT(3)
GLOBAL_UNCERTAINTY_ASSIGNED_CONTEXT((#1029))
GLOBAL_UNIT_ASSIGNED_CONTEXT((#1071,#1075,#1091))
REPRESENTATION_CONTEXT('simple_block_rawpiece','TOP_LEVEL_ASSEMBLY_PART')
);
#1029=UNCERTAINTY_MEASURE_WITH_UNIT(LENGTH_MEASURE(2.E-005),#1071,
'DISTANCE_ACCURACY_VALUE','Maximum Tolerance applied to model');

/*****
* Application object: MACHINING_WORKINGSTEP (#1030)
* ITS_OPERATION: #1030, #1031, #1011
* ITS_ID: #1030 ['WS 1']
* ITS_FEATURE: #1030, #1032, #1033, #1034, #1035, #1117
*/
#1030=MACHINING_WORKINGSTEP('WS 1','machining','','');
#1031=MACHINING_OPERATION_RELATIONSHIP('','machining',#1030,#1011);
#1032=MACHINING_FEATURE_RELATIONSHIP('','machining',#1030,#1033);
#1033=MACHINING_FEATURE_PROCESS('','machining','','');
#1034=PROPERTY_PROCESS('machining','machining',#1033,'');
#1035=PROCESS_PROPERTY_ASSOCIATION('','machining',#1034,#1117);

/*****
* Application object: MILLING_MACHINE_FUNCTIONS (#1040)
* CHIP_REMOVAL: #1040, #1041, #1042, #1043, #1044 ['chip removal off']
* COOLANT: #1040, #1045, #1046, #1047, #1048 ['coolant off']
* THROUGH_SPINDLE_COOLANT: #1040, #1049, #1050, #1051, #1052 ['through spindle
coolant off']
*/
#1040=MACHINING_FUNCTIONS('','milling','','');
#1041=ACTION_PROPERTY('chip removal','milling',#1040);
#1042=ACTION_PROPERTY_REPRESENTATION('','milling',#1041,#1043);
#1043=REPRESENTATION('constant',(#1044),#564);
#1044=DESCRIPTIVE_REPRESENTATION_ITEM('constant','chip removal off');
#1045=ACTION_PROPERTY('coolant','milling',#1040);
#1046=ACTION_PROPERTY_REPRESENTATION('','milling',#1045,#1047);
#1047=REPRESENTATION('constant',(#1048),#564);
#1048=DESCRIPTIVE_REPRESENTATION_ITEM('constant','coolant off');
#1049=ACTION_PROPERTY('through spindle coolant','milling',#1040);
#1050=ACTION_PROPERTY_REPRESENTATION('','milling',#1049,#1051);
#1051=REPRESENTATION('constant',(#1052),#564);
#1052=DESCRIPTIVE_REPRESENTATION_ITEM('constant',
'through spindle coolant off');

/*****
* Application object: MILLING_TECHNOLOGY (#1053)
* SPINDLE: #1053, #1054, #1055, #1056, #1057
* FEEDRATE: #1053, #1058, #1059, #1060, #1061
*/
#1053=MACHINING_TECHNOLOGY('','milling','','');
#1054=ACTION_PROPERTY('spindle','milling',#1053);
```

```

#1055=ACTION_PROPERTY_REPRESENTATION('rotational speed','milling',#1054,
#1056);
#1056=MACHINING_SPINDLE_SPEED_REPRESENTATION('spindle speed',(#1057),#564);
#1057=MEASURE_REPRESENTATION_ITEM('rotational speed',NUMERIC_MEASURE(0.),
#1006);
#1058=ACTION_PROPERTY('feedrate','milling',#1053);
#1059=ACTION_PROPERTY_REPRESENTATION('feed speed','milling',#1058,#1060);
#1060=MACHINING_FEED_SPEED_REPRESENTATION('feed speed',(#1061),#564);
#1061=MEASURE_REPRESENTATION_ITEM('feed speed',NUMERIC_MEASURE(0.),#1008);

/*****
* Application object: MILLING_TECHNOLOGY (#1062)
* SPINDLE: #1062, #1063, #1064, #1065, #1066
* FEEDRATE: #1062, #1067, #1068, #1069, #1070
*/
#1062=MACHINING_TECHNOLOGY('','milling','','');
#1063=ACTION_PROPERTY('spindle','milling',#1062);
#1064=ACTION_PROPERTY_REPRESENTATION('rotational speed','milling',#1063,
#1065);
#1065=MACHINING_SPINDLE_SPEED_REPRESENTATION('spindle speed',(#1066),#564);
#1066=MEASURE_REPRESENTATION_ITEM('rotational speed',NUMERIC_MEASURE(0.),
#1006);
#1067=ACTION_PROPERTY('feedrate','milling',#1062);
#1068=ACTION_PROPERTY_REPRESENTATION('feed speed','milling',#1067,#1069);
#1069=MACHINING_FEED_SPEED_REPRESENTATION('feed speed',(#1070),#564);
#1070=MEASURE_REPRESENTATION_ITEM('feed speed',NUMERIC_MEASURE(250.),#1008);

/*****
* Application object: NAMED_UNIT (#1071)
*/
#1071=(
LENGTH_UNIT()
NAMED_UNIT(*)
SI_UNIT(.MILLI.,.METRE.)
);

/*****
* Application object: NAMED_UNIT (#1075)
*/
#1075=(
CONVERSION_BASED_UNIT('degree',#1077)
NAMED_UNIT(#1076)
PLANE_ANGLE_UNIT()
);
#1076=DIMENSIONAL_EXPONENTS(0.,0.,0.,0.,0.,0.);
#1077=PLANE_ANGLE_MEASURE_WITH_UNIT(PLANE_ANGLE_MEASURE(0.01745329252),#1087);

/*****
* Application object: NAMED_UNIT (#1087)
*/
#1087=(
NAMED_UNIT(*)
PLANE_ANGLE_UNIT()
SI_UNIT($,.RADIAN.)

```

```

);

/*****
 * Application object: NAMED_UNIT (#1091)
 */
#1091= (
NAMED_UNIT(*)
SI_UNIT($, .STERADIAN.)
SOLID_ANGLE_UNIT()
);

/*****
 * Application object: NAMED_UNIT (#1095)
 */
#1095= (
CONVERSION_BASED_UNIT('minute', #1097)
NAMED_UNIT(#1096)
TIME_UNIT()
);
#1096=DIMENSIONAL_EXPONENTS(0., 0., 1., 0., 0., 0.);
#1097=TIME_MEASURE_WITH_UNIT(TIME_MEASURE(60.), #1098);

/*****
 * Application object: NAMED_UNIT (#1098)
 */
#1098= (
NAMED_UNIT(*)
SI_UNIT($, .SECOND.)
TIME_UNIT()
);

/*****
 * Application object: NAMED_UNIT (#1099)
 */
#1099=CONTEXT_DEPENDENT_UNIT(#1100, 'count');
#1100=DIMENSIONAL_EXPONENTS(0., 0., 0., 0., 0., 0.);

/*****
 * Application object: PERSON_AND_ADDRESS (#1101)
 */
#1101=PERSON(' ', ' ', ' ', (' '), $, $);

/*****
 * Application object: PERSON_AND_ADDRESS (#1102)
 */
#1102=PERSON(' ', ' ', ' ', (' '), $, $);

/*****
 * Application object: TOOLPATH_FEATURE (#1111)
 * ITS_WORKPIECE: #1111, #20, #19
 * FEATURE_PLACEMENT: #1111, #1112, #1113, #1114, #1115
 * ITS_ID: #1111 ['']
 */
#1111=INSTANCED_FEATURE('', 'toolpath', '', 'toolpath', #20, .F.);

```

```

#1112=PRODUCT_DEFINITION_SHAPE('orientation','toolpath',#1111);
#1113=SHAPE_DEFINITION_REPRESENTATION(#1112,#1114);
#1114=SHAPE_REPRESENTATION_WITH_PARAMETERS('',( #1115),#565);
#1115=AXIS2_PLACEMENT_3D('orientation',#1116,#589,#590);
#1116=CARTESIAN_POINT('origin',(0.,0.,0.));

/*****
* Application object: TOOLPATH_FEATURE (#1117)
* ITS_WORKPIECE: #1117, #20, #19
* FEATURE_PLACEMENT: #1117, #1118, #1119, #1120, #1121
* ITS_ID: #1117 ['']
* ITS_OPERATIONS [*]: #1117, #1122, #1123, #1124, #1125, #1126, #1127, #1011
* ITS_OPERATIONS [*]: #1117, #1035, #1034, #1033, #1032, #1030, #1031, #1011
*/
#1117=INSTANCED_FEATURE('','toolpath','','toolpath',#20,.F.);
#1118=PRODUCT_DEFINITION_SHAPE('orientation','toolpath',#1117);
#1119=SHAPE_DEFINITION_REPRESENTATION(#1118,#1120);
#1120=SHAPE_REPRESENTATION_WITH_PARAMETERS('',( #1121),#1128);
#1121=AXIS2_PLACEMENT_3D('orientation',#1129,#1130,#1131);
#1122=PROCESS_PROPERTY_ASSOCIATION('','toolpath',#1123,#1117);
#1123=PROPERTY_PROCESS('machining','toolpath',#1124,'');
#1124=MACHINING_FEATURE_PROCESS('','toolpath','','');
#1125=MACHINING_FEATURE_RELATIONSHIP('','toolpath',#1126,#1124);
#1126=MACHINING_WORKINGSTEP('','toolpath','','');
#1127=MACHINING_OPERATION_RELATIONSHIP('','toolpath',#1126,#1011);
#1128=(
GEOMETRIC_REPRESENTATION_CONTEXT(3)
GLOBAL_UNIT_ASSIGNED_CONTEXT((#1071,#1075,#1091))
REPRESENTATION_CONTEXT('MILLIMETRE DEGREE STERADIAN','')
);
#1129=CARTESIAN_POINT('origin',(0.,0.,0.));
#1130=DIRECTION('Z direction',(0.,0.,1.));
#1131=DIRECTION('X direction',(1.,0.,0.));

/*****
* Application object: WORKPLAN (#1134)
* ITS_ELEMENTS [1]: #1134, #1135, #1030
* ITS_ID: #1134 ['main workplan']
*/
#1134=MACHINING_WORKPLAN('main workplan','','','');
#1135=MACHINING_PROCESS_SEQUENCE_RELATIONSHIP('','',#1134,#1030,1.);

/*****
* Application object: ENDMILL (#1150)
* ITS_ID: #1150 ['1']
* EFFECTIVE_CUTTING_DIAMETER: #1150, #1152, #1153, #1154, #1155
* MAXIMUM_DEPTH_OF_CUT: #1150, #1152, #1153, #1154, #1156
* HAND_OF_CUT: #1150, #1152, #1153, #1154, #1157 ['right']
* EDGE_RADIUS: #1150, #1152, #1153, #1154, #1158
*/
#1150=MACHINING_TOOL('1','endmill',(#1011),#1151);
#1151=ACTION_RESOURCE_TYPE('milling cutting tool');
#1152=RESOURCE_PROPERTY('tool body','','#1150);
#1153=RESOURCE_PROPERTY_REPRESENTATION('','',#1152,#1154);

```

## ISO 10303-238:2007(E)

```
#1154=MACHINING_TOOL_BODY_REPRESENTATION('endmill', (#1155,#1156,#1157,
#1158),#564);
#1155=(
LENGTH_MEASURE_WITH_UNIT()
MEASURE_REPRESENTATION_ITEM()
MEASURE_WITH_UNIT(LENGTH_MEASURE(20.),#1071)
REPRESENTATION_ITEM('effective cutting diameter')
);
#1156=(
LENGTH_MEASURE_WITH_UNIT()
MEASURE_REPRESENTATION_ITEM()
MEASURE_WITH_UNIT(LENGTH_MEASURE(20.),#1071)
REPRESENTATION_ITEM('maximum depth of cut')
);
#1157=DESCRIPTIVE_REPRESENTATION_ITEM('hand of cut','right');
#1158=(
LENGTH_MEASURE_WITH_UNIT()
MEASURE_REPRESENTATION_ITEM()
MEASURE_WITH_UNIT(LENGTH_MEASURE(0.),#1071)
REPRESENTATION_ITEM('edge radius')
);

#1160=APPLICATION_PROTOCOL_DEFINITION('international standard',
'integrated_cnc_schema',2006,#17);
ENDSEC;
END-ISO-10303-21;
```

## J.6 Data set for ISO 14649-11 example #1 (CC3)

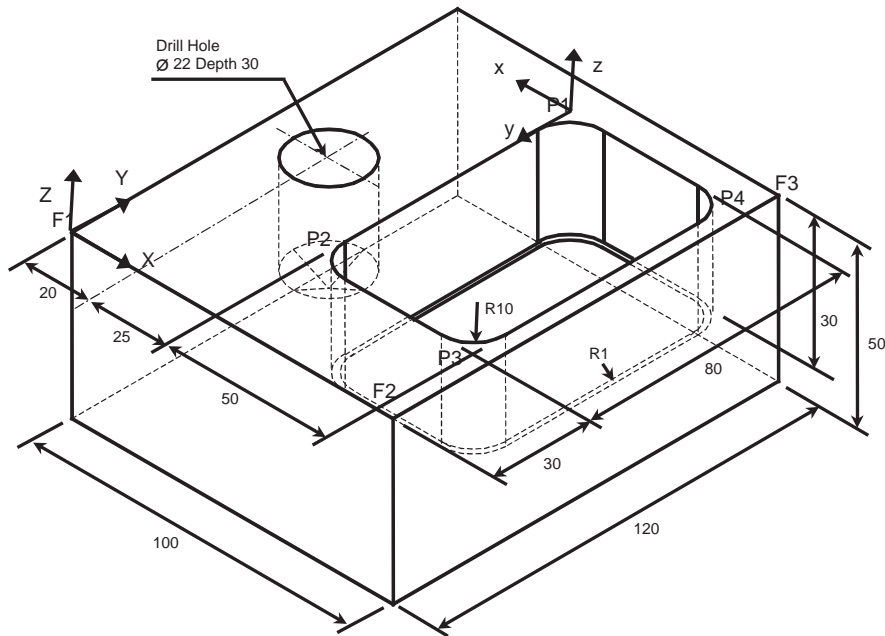
The following test case is defined by Annex E of ISO 14649-11:2004. It defines a simple machining project for a block that contains a hole and a pocket as shown in Figure J.2. The data set follows the original ordering of application object instances in the ISO 14649-11 example. This example is a conformance class three file and contains no toolpaths. The processing system must generate toolpaths from the supplied features in order to machine the part. .

```
ISO-10303-21;
HEADER;
FILE_DESCRIPTION(
/* description */ ('AP238 AIM version of ISO14649-11 example #1'),
/* implementation_level */ '2;1');

FILE_NAME(
/* name */ 'p11_example1_aim',
/* time_stamp */ '2006-06-22T10:50:52-04:00',
/* author */ ('Dave Loffredo (loffredo@steptools.com)'),
/* organization */ (''),
/* preprocessor_version */ 'ST-DEVELOPER v11',
/* originating_system */ '',
/* authorisation */ '');

FILE_SCHEMA (('INTEGRATED_CNC_SCHEMA'));
```





**Figure J.2 — Workpiece from ISO 14649-11 example #1**

ENDSEC;

DATA;

```

/*****
 * Application object: PROPERTY_PARAMETER (#100)
 * PARAMETER_NAME: #100 ['E=200000N/M2']
 */
#100=REPRESENTATION_ITEM('E=200000N/M2');

/*****
 * Application object: MATERIAL (#200)
 * MATERIAL_IDENTIFIER: #200 ['STEEL']
 * STANDARD_IDENTIFIER: #200, #201, #202 ['ST-50']
 * MATERIAL_PROPERTY [*]: #200, #203, #204, #205, #100
 */
#200=MATERIAL_DESIGNATION('STEEL', (#307, #407));
#201=APPLIED_DOCUMENT_REFERENCE(#202, '', (#200));
#202=DOCUMENT('ST-50', '', '', $);
#203=MATERIAL_DESIGNATION_CHARACTERIZATION('', '', #200, #204);
#204=MATERIAL_PROPERTY_REPRESENTATION($, #205, $);
#205=REPRESENTATION('', (#100), $);

/*****
 * Application object: WORKPIECE (#300)
 * ITS_ID: #300 ['STOCK']
 * ITS_BOUNDING_GEOMETRY: #300, #301, #302, #303, #304, #305
 * ITS_MATERIAL [1]: #300, #306, #307, #200
 */
#300=PRODUCT_DEFINITION('STOCK', '', #308, #312);

```

ISO 10303-238:2007(E)

```

#301=MAKE_FROM_USAGE_OPTION('','',$,#300,#302,0,'',$);
#302=PRODUCT_DEFINITION($,$,$,#312);
#303=PRODUCT_DEFINITION_SHAPE('',$,#302);
#304=SHAPE_DEFINITION_REPRESENTATION(#303,#305);
#305=BLOCK_SHAPE_REPRESENTATION($,(#313,#317,#318,#319),$);
#306=MAKE_FROM_USAGE_OPTION('','',$,#300,#307,1,'',$);
#307=PRODUCT_DEFINITION('',$,$,$);
#308=PRODUCT_DEFINITION_FORMATION('1.0','Workpiece',#309);
#309=PRODUCT('WP','AP-238 CC1','',$,#310);
#310=PRODUCT_CONTEXT('CNC Machining',#311,'manufacturing');
#311=APPLICATION_CONTEXT(
'Application protocol for the exchange of CNC data');
#312=PRODUCT_DEFINITION_CONTEXT('CNC Machining',#311,'manufacturing');
#313=AXIS2_PLACEMENT_3D('orientation',#314,#315,#316);
#314=CARTESIAN_POINT('',(0.,0.,0.));
#315=DIRECTION('',(0.,0.,1.));
#316=DIRECTION('',(1.,0.,0.));
#317=(
LENGTH_MEASURE_WITH_UNIT()
MEASURE_REPRESENTATION_ITEM()
MEASURE_WITH_UNIT(LENGTH_MEASURE(100.),#1601)
REPRESENTATION_ITEM('length')
);
#318=(
LENGTH_MEASURE_WITH_UNIT()
MEASURE_REPRESENTATION_ITEM()
MEASURE_WITH_UNIT(LENGTH_MEASURE(100.),#1601)
REPRESENTATION_ITEM('width')
);
#319=(
LENGTH_MEASURE_WITH_UNIT()
MEASURE_REPRESENTATION_ITEM()
MEASURE_WITH_UNIT(LENGTH_MEASURE(100.),#1601)
REPRESENTATION_ITEM('height')
);
#320=APPLICATION_PROTOCOL_DEFINITION('international standard',
'integrated_cnc_schema',2006,#311);

/*****
* Application object: WORKPIECE (#400)
* ITS_ID: #400 ['SIMPLE WORKPIECE']
* GLOBAL_TOLERANCE: #400, #402, #403, #404, #405
* ITS_MATERIAL [1]: #400, #406, #407, #200
* CLAMPING_POSITIONS [*]: #400, #408, #409, #410, #411
* CLAMPING_POSITIONS [*]: #400, #408, #409, #410, #415
* CLAMPING_POSITIONS [*]: #400, #408, #409, #410, #419
* CLAMPING_POSITIONS [*]: #400, #408, #409, #410, #423
* ITS_RAWPIECE: #400, #424, #300
* SHAPE_DEFINITION: #400, #401
*/
#400=PRODUCT_DEFINITION('SIMPLE WORKPIECE','',$,#425,#312);
#401=PRODUCT_DEFINITION_SHAPE('',$,#400);
#402=PROPERTY_DEFINITION('global tolerance','',$,#400);
#403=PROPERTY_DEFINITION_REPRESENTATION(#402,#404);

```

```

#404=SHAPE_REPRESENTATION('', (#405), #427);
#405=(
LENGTH_MEASURE_WITH_UNIT()
MEASURE_REPRESENTATION_ITEM()
MEASURE_WITH_UNIT(LENGTH_MEASURE(0.01), #1601)
REPRESENTATION_ITEM('')
);
#406=MAKE_FROM_USAGE_OPTION('','', '#400, #407, 1, '', $);
#407=PRODUCT_DEFINITION('','', $, $);
#408=PROPERTY_DEFINITION('clamping position', '#400);
#409=PROPERTY_DEFINITION_REPRESENTATION(#408, #410);
#410=SHAPE_REPRESENTATION('', (#411, #415, #419, #423), #427);
#411=CARTESIAN_POINT('CLAMPING_POSITION1', (0., 20., 25.));
#415=CARTESIAN_POINT('CLAMPING_POSITION2', (100., 20., 25.));
#419=CARTESIAN_POINT('CLAMPING_POSITION3', (0., 100., 25.));
#423=CARTESIAN_POINT('CLAMPING_POSITION4', (100., 100., 25.));
#424=MAKE_FROM_USAGE_OPTION('','', '#400, #300, 0, '', #433);
#425=PRODUCT_DEFINITION_FORMATION('1.0', 'Workpiece', #426);
#426=PRODUCT('WP', 'AP-238 CC1', '#310);
#427=(
GEOMETRIC_REPRESENTATION_CONTEXT(3)
GLOBAL_UNIT_ASSIGNED_CONTEXT((#1601, #428, #432))
REPRESENTATION_CONTEXT('MILLIMETRE DEGREE STERADIAN', '')
);
#428=(
CONVERSION_BASED_UNIT('degree', #430)
NAMED_UNIT(#429)
PLANE_ANGLE_UNIT()
);
#429=DIMENSIONAL_EXPONENTS(0., 0., 0., 0., 0., 0.);
#430=PLANE_ANGLE_MEASURE_WITH_UNIT(PLANE_ANGLE_MEASURE(0.01745329252), #431);
#431=(
NAMED_UNIT(*)
PLANE_ANGLE_UNIT()
SI_UNIT($, .RADIAN.)
);
#432=(
NAMED_UNIT(*)
SI_UNIT($, .STERADIAN.)
SOLID_ANGLE_UNIT()
);
#433=MEASURE_WITH_UNIT(COUNT_MEASURE(1.), #434);
#434=CONTEXT_DEPENDENT_UNIT(#435, 'count');
#435=DIMENSIONAL_EXPONENTS(0., 0., 0., 0., 0., 0.);

/*****
* Application object: CUTTING_COMPONENT (#500)
* TOOL_OFFSET_LENGTH: #500, #501, #502, #503, #504
*/
#500=MACHINING_CUTTING_COMPONENT('', '$, $, ', '');
#501=RESOURCE_PROPERTY('offset length', '#500);
#502=RESOURCE_PROPERTY_REPRESENTATION('', '#501, #503);
#503=REPRESENTATION('', (#504), #505);
#504=(

```

ISO 10303-238:2007(E)

```

LENGTH_MEASURE_WITH_UNIT()
MEASURE_REPRESENTATION_ITEM()
MEASURE_WITH_UNIT(LENGTH_MEASURE(80.),#1601)
REPRESENTATION_ITEM('')
);
#505=REPRESENTATION_CONTEXT('','units not necessary');

/*****
* Application object: ENDMILL (#600)
* ITS_ID: #600 ['MILL 20MM']
* ITS_CUTTING_EDGE [*]: #600, #605, #500
* ITS_CUTTING_EDGE [*]: #600, #606, #500
* ITS_CUTTING_EDGE [*]: #600, #607, #500
* ITS_CUTTING_EDGE [*]: #600, #608, #500
* OVERALL_ASSEMBLY_LENGTH: #600, #609, #610, #700, #704
* EFFECTIVE_CUTTING_DIAMETER: #600, #609, #610, #700, #705
* MAXIMUM_DEPTH_OF_CUT: #600, #609, #610, #700, #706
* HAND_OF_CUT: #600, #609, #610, #700, #702 ['right']
* COOLANT_THROUGH_TOOL: #600, #609, #610, #700, #701 ['not supported']
* NUMBER_OF_EFFECTIVE_TEETH: #600, #609, #610, #700, #703 [4]
* EDGE_RADIUS: #600, #609, #610, #700, #707
*/
#600=MACHINING_TOOL('MILL 20MM','endmill',(#4300,#4000,#1300),#611);
#605=ACTION_RESOURCE_RELATIONSHIP('','',#600,#500);
#606=ACTION_RESOURCE_RELATIONSHIP('','',#600,#500);
#607=ACTION_RESOURCE_RELATIONSHIP('','',#600,#500);
#608=ACTION_RESOURCE_RELATIONSHIP('','',#600,#500);
#609=RESOURCE_PROPERTY('tool body','',#600);
#610=RESOURCE_PROPERTY_REPRESENTATION('','',#609,#700);
#611=ACTION_RESOURCE_TYPE('milling cutting tool');

#700=MACHINING_TOOL_BODY_REPRESENTATION('endmill',(#702,#701,#703,#704,
#705,#706,#707),#505);
#701=DESCRIPTIVE_REPRESENTATION_ITEM('coolant through tool',
'not supported');
#702=DESCRIPTIVE_REPRESENTATION_ITEM('hand of cut','right');
#703=MEASURE_REPRESENTATION_ITEM('number of effective teeth',
COUNT_MEASURE(4.),#434);
#704=(
LENGTH_MEASURE_WITH_UNIT()
MEASURE_REPRESENTATION_ITEM()
MEASURE_WITH_UNIT(LENGTH_MEASURE(80.),#1601)
REPRESENTATION_ITEM('overall assembly length')
);
#705=(
LENGTH_MEASURE_WITH_UNIT()
MEASURE_REPRESENTATION_ITEM()
MEASURE_WITH_UNIT(LENGTH_MEASURE(20.),#1601)
REPRESENTATION_ITEM('effective cutting diameter')
);
#706=(
LENGTH_MEASURE_WITH_UNIT()
MEASURE_REPRESENTATION_ITEM()
MEASURE_WITH_UNIT(LENGTH_MEASURE(30.),#1601)

```

```

REPRESENTATION_ITEM('maximum depth of cut')
);
#707=(
LENGTH_MEASURE_WITH_UNIT()
MEASURE_REPRESENTATION_ITEM()
MEASURE_WITH_UNIT(LENGTH_MEASURE(0.05),#1601)
REPRESENTATION_ITEM('edge radius')
);

/*****
* Application object: MILLING_TECHNOLOGY (#800)
* SYNCHRONIZE_SPINDLE_WITH_FEED: #800, #801, #802, #803, #804 ['not
synchronized']
* FEEDRATE_PER_TOOTH: #800, #805, #806, #807, #808
* SPINDLE: #800, #809, #810, #811, #812
* CUTSPEED: #800, #813, #814, #815, #816
* INHIBIT_FEEDRATE_OVERRIDE: #800, #817, #818, #819, #820 ['override not
allowed']
* FEEDRATE: #800, #821, #822, #823, #824
* FEEDRATE_REFERENCE: #800, #825, #826, #827, #828 ['tool center point']
* INHIBIT_SPINDLE_OVERRIDE: #800, #829, #830, #831, #832 ['override not
allowed']
*/
#800=MACHINING_TECHNOLOGY('','milling','','');
#801=ACTION_PROPERTY('synchronize spindle with feed','milling',#800);
#802=ACTION_PROPERTY_REPRESENTATION('','milling',#801,#803);
#803=REPRESENTATION('',( #804 ),#505);
#804=DESCRIPTIVE_REPRESENTATION_ITEM('','not synchronized');
#805=ACTION_PROPERTY('feedrate','milling',#800);
#806=ACTION_PROPERTY_REPRESENTATION('feed per tooth','milling',#805,#807);
#807=MACHINING_FEED_SPEED_REPRESENTATION('feed per tooth',( #808 ),#505);
#808=MEASURE_REPRESENTATION_ITEM('feed per tooth',$,#833);
#809=ACTION_PROPERTY('spindle','milling',#800);
#810=ACTION_PROPERTY_REPRESENTATION('rotational speed','milling',#809,#811);
#811=MACHINING_SPINDLE_SPEED_REPRESENTATION('spindle speed',( #812 ),#505);
#812=MEASURE_REPRESENTATION_ITEM('rotational speed',NUMERIC_MEASURE(12.),
#837);
#813=ACTION_PROPERTY('spindle','milling',#800);
#814=ACTION_PROPERTY_REPRESENTATION('surface speed','milling',#813,#815);
#815=MACHINING_SPINDLE_SPEED_REPRESENTATION('cutting speed',( #816 ),#505);
#816=MEASURE_REPRESENTATION_ITEM('surface speed',$,#837);
#817=ACTION_PROPERTY('inhibit feedrate override','milling',#800);
#818=ACTION_PROPERTY_REPRESENTATION('','milling',#817,#819);
#819=REPRESENTATION('',( #820 ),#505);
#820=DESCRIPTIVE_REPRESENTATION_ITEM('','override not allowed');
#821=ACTION_PROPERTY('feedrate','milling',#800);
#822=ACTION_PROPERTY_REPRESENTATION('feed speed','milling',#821,#823);
#823=MACHINING_FEED_SPEED_REPRESENTATION('feed speed',( #824 ),#505);
#824=MEASURE_REPRESENTATION_ITEM('feed speed',NUMERIC_MEASURE(0.04),#833);
#825=ACTION_PROPERTY('feedrate reference','milling',#800);
#826=ACTION_PROPERTY_REPRESENTATION('','milling',#825,#827);
#827=REPRESENTATION('',( #828 ),#505);
#828=DESCRIPTIVE_REPRESENTATION_ITEM('','tool center point');
#829=ACTION_PROPERTY('inhibit spindle override','milling',#800);

```

```

#830=ACTION_PROPERTY_REPRESENTATION('', 'milling', #829, #831);
#831=REPRESENTATION('', (#832), #505);
#832=DESCRIPTIVE_REPRESENTATION_ITEM('', 'override not allowed');
#833=DERIVED_UNIT((#834, #835));
#834=DERIVED_UNIT_ELEMENT(#1601, 1.);
#835=DERIVED_UNIT_ELEMENT(#836, -1.);
#836=(
NAMED_UNIT(*)
SI_UNIT($, .SECOND.)
TIME_UNIT()
);
#837=DERIVED_UNIT((#838));
#838=DERIVED_UNIT_ELEMENT(#836, -1.);
#839=NAME_ATTRIBUTE('millimetre/second', #833);
#840=NAME_ATTRIBUTE('rotation/second', #837);

/*****
* Application object: MILLING_MACHINE_FUNCTIONS (#900)
* CHIP_REMOVAL: #900, #901, #902, #903, #904 ['chip removal on']
* COOLANT: #900, #905, #906, #907, #908 ['coolant on']
* THROUGH_SPINDLE_COOLANT: #900, #909, #910, #911, #912 ['through spindle
coolant off']
*/
#900=MACHINING_FUNCTIONS('', 'milling', '', '');
#901=ACTION_PROPERTY('chip removal', 'milling', #900);
#902=ACTION_PROPERTY_REPRESENTATION('', 'milling', #901, #903);
#903=REPRESENTATION('constant', (#904), #505);
#904=DESCRIPTIVE_REPRESENTATION_ITEM('constant', 'chip removal on');
#905=ACTION_PROPERTY('coolant', 'milling', #900);
#906=ACTION_PROPERTY_REPRESENTATION('', 'milling', #905, #907);
#907=REPRESENTATION('constant', (#908), #505);
#908=DESCRIPTIVE_REPRESENTATION_ITEM('constant', 'coolant on');
#909=ACTION_PROPERTY('through spindle coolant', 'milling', #900);
#910=ACTION_PROPERTY_REPRESENTATION('', 'milling', #909, #911);
#911=REPRESENTATION('constant', (#912), #505);
#912=DESCRIPTIVE_REPRESENTATION_ITEM('constant',
'through spindle coolant off');

/*****
* Application object: PLUNGE_RAMP (#1000)
* ANGLE: #1000, #1001, #1002, #1003, #1004
*/
#1000=MACHINING_APPROACH_RETRACT_STRATEGY('', 'plunge ramp', '', '');
#1001=ACTION_PROPERTY('plunge angle', 'plunge ramp', #1000);
#1002=ACTION_PROPERTY_REPRESENTATION('', 'plunge ramp', #1001, #1003);
#1003=REPRESENTATION('', (#1004), #505);
#1004=(
MEASURE_REPRESENTATION_ITEM()
MEASURE_WITH_UNIT(PLANE_ANGLE_MEASURE(45.), #428)
PLANE_ANGLE_MEASURE_WITH_UNIT()
REPRESENTATION_ITEM('')
);

/*****

```

```

* Application object: PLUNGE_RAMP (#1100)
* ANGLE: #1100, #1101, #1102, #1103, #1104
*/
#1100=MACHINING_APPROACH_RETRACT_STRATEGY('','plunge ramp','','');
#1101=ACTION_PROPERTY('plunge angle','plunge ramp',#1100);
#1102=ACTION_PROPERTY_REPRESENTATION('','plunge ramp',#1101,#1103);
#1103=REPRESENTATION('',( #1104),#505);
#1104=(
MEASURE_REPRESENTATION_ITEM()
MEASURE_WITH_UNIT(PLANE_ANGLE_MEASURE(45.),#428)
PLANE_ANGLE_MEASURE_WITH_UNIT()
REPRESENTATION_ITEM('')
);

/*****
* Application object: BIDIRECTIONAL (#1200)
* FEED_DIRECTION: #1200, #1201, #1202, #1203, #1204
* STEPOVER_DIRECTION: #1200, #1205, #1206, #1207, #1208 ['left']
* OVERLAP: #1200, #1209, #1210, #1211, #1212
* ALLOW_MULTIPLE_PASSES: #1200, #1213, #1214, #1215, #1216 ['multiple passes
allowed']
*/
#1200=MILLING_TYPE_STRATEGY('','bidirectional','','');
#1201=ACTION_PROPERTY('feed direction','bidirectional',#1200);
#1202=ACTION_PROPERTY_REPRESENTATION('','bidirectional',#1201,#1203);
#1203=REPRESENTATION('',( #1204),#505);
#1204=DIRECTION('STRATEGY PLANAR FACE1: 1.DIRECTION',(0.,1.,0.));
#1205=ACTION_PROPERTY('stepover direction','bidirectional',#1200);
#1206=ACTION_PROPERTY_REPRESENTATION('','bidirectional',#1205,#1207);
#1207=REPRESENTATION('',( #1208),#505);
#1208=DESCRIPTIVE_REPRESENTATION_ITEM('','left');
#1209=ACTION_PROPERTY('overlap ratio','bidirectional',#1200);
#1210=ACTION_PROPERTY_REPRESENTATION('','bidirectional',#1209,#1211);
#1211=REPRESENTATION('',( #1212),#505);
#1212=(
MEASURE_REPRESENTATION_ITEM()
MEASURE_WITH_UNIT(RATIO_MEASURE(5.),#1217)
RATIO_MEASURE_WITH_UNIT()
REPRESENTATION_ITEM('')
);
#1213=ACTION_PROPERTY('multiple passes','bidirectional',#1200);
#1214=ACTION_PROPERTY_REPRESENTATION('','bidirectional',#1213,#1215);
#1215=REPRESENTATION('',( #1216),#505);
#1216=DESCRIPTIVE_REPRESENTATION_ITEM('','multiple passes allowed');
#1217=RATIO_UNIT(#1218);
#1218=DIMENSIONAL_EXPONENTS(0.,0.,0.,0.,0.,0.);

/*****
* Application object: PLANE_FINISH_MILLING (#1300)
* RETRACT: #1300, #1301, #1100
* APPROACH: #1300, #1302, #1000
* ITS_TECHNOLOGY: #1300, #1303, #800
* OVERCUT_LENGTH: #1300, #1304, #1305, #1306, #1307
* ITS_TOOL: #1300, #600

```

```

* RETRACT_PLANE: #1300, #1308, #1309, #1310, #1311
* AXIAL_CUTTING_DEPTH: #1300, #1312, #1313, #1314, #1315
* ITS_MACHINING_STRATEGY: #1300, #1316, #1200
* ALLOWANCE_BOTTOM: #1300, #1317, #1318, #1319, #1320
* ITS_MACHINE_FUNCTIONS: #1300, #1321, #900
* ITS_ID: #1300 ['FINISH PLANAR FACE1']
*/
#1300=PLANE_MILLING_OPERATION('FINISH PLANAR FACE1','finishing','',');
#1301=MACHINING_STRATEGY_RELATIONSHIP('retract','finishing',#1300,#1100);
#1302=MACHINING_STRATEGY_RELATIONSHIP('approach','finishing',#1300,#1000);
#1303=MACHINING_TECHNOLOGY_RELATIONSHIP('','finishing',#1300,#800);
#1304=ACTION_PROPERTY('overcut length','finishing',#1300);
#1305=ACTION_PROPERTY_REPRESENTATION('','finishing',#1304,#1306);
#1306=REPRESENTATION('',( #1307),#505);
#1307=(
LENGTH_MEASURE_WITH_UNIT()
MEASURE_REPRESENTATION_ITEM()
MEASURE_WITH_UNIT(LENGTH_MEASURE(5.),#1601)
REPRESENTATION_ITEM('')
);
#1308=ACTION_PROPERTY('retract plane','finishing',#1300);
#1309=ACTION_PROPERTY_REPRESENTATION('','finishing',#1308,#1310);
#1310=REPRESENTATION('',( #1311),#505);
#1311=(
LENGTH_MEASURE_WITH_UNIT()
MEASURE_REPRESENTATION_ITEM()
MEASURE_WITH_UNIT(LENGTH_MEASURE(10.),#1601)
REPRESENTATION_ITEM('')
);
#1312=ACTION_PROPERTY('axial cutting depth','finishing',#1300);
#1313=ACTION_PROPERTY_REPRESENTATION('','finishing',#1312,#1314);
#1314=REPRESENTATION('',( #1315),#505);
#1315=(
LENGTH_MEASURE_WITH_UNIT()
MEASURE_REPRESENTATION_ITEM()
MEASURE_WITH_UNIT(LENGTH_MEASURE(2.5),#1601)
REPRESENTATION_ITEM('')
);
#1316=MACHINING_STRATEGY_RELATIONSHIP('machining','finishing',#1300,#1200);
#1317=ACTION_PROPERTY('allowance bottom','finishing',#1300);
#1318=ACTION_PROPERTY_REPRESENTATION('','finishing',#1317,#1319);
#1319=REPRESENTATION('',( #1320),#505);
#1320=(
LENGTH_MEASURE_WITH_UNIT()
MEASURE_REPRESENTATION_ITEM()
MEASURE_WITH_UNIT($,#1601)
REPRESENTATION_ITEM('')
);
#1321=MACHINING_FUNCTIONS_RELATIONSHIP('','finishing',#1300,#900);

/*****
* Application object: TOLERANCED_LENGTH_MEASURE (#1400)
* VALUE_COMPONENT: #1400 [120]
*****/

```



```

* Application object: QUALIFIED_PLUS_MINUS_VALUE (#1400)
* UPPER_LIMIT: #1400, #1401 [0.3]
* LOWER_LIMIT: #1400, #1402 [0.3]
*/
#1400=(
LENGTH_MEASURE_WITH_UNIT()
MEASURE_REPRESENTATION_ITEM()
MEASURE_WITH_UNIT(LENGTH_MEASURE(120.),#1601)
QUALIFIED_REPRESENTATION_ITEM((#1402,#1401))
REPRESENTATION_ITEM('distance')
);
#1401=STANDARD_UNCERTAINTY('upper limit','',0.3);
#1402=STANDARD_UNCERTAINTY('lower limit','',0.3);

/*****
* Application object: LINEAR_PATH (#1500)
* ITS_DIRECTION: #1500, #1501, #1502, #1503, #1504
* DISTANCE: #1500, #1505, #1506, #1507, #1400
*/
#1500=PATH_FEATURE_COMPONENT('','linear',#1509,.F.);
#1501=PROPERTY_DEFINITION('','linear',#1500);
#1502=PROPERTY_DEFINITION_REPRESENTATION(#1501,#1503);
#1503=DIRECTION_SHAPE_REPRESENTATION('',( #1504),#505);
#1504=DIRECTION('COURSE OF TRAVEL DIRECTION',(0.,1.,0.));
#1505=PROPERTY_DEFINITION('','linear',#1500);
#1506=SHAPE_DEFINITION_REPRESENTATION(#1505,#1507);
#1507=SHAPE_REPRESENTATION_WITH_PARAMETERS('',( #1400),#427);
#1508=FEATURE_COMPONENT_DEFINITION('feature component','shared by all');
#1509=PRODUCT_DEFINITION_SHAPE('feature component',$,#1508);

/*****
* Application object: NUMERIC_PARAMETER (#1600)
* ITS_PARAMETER_UNIT: #1600, #1601
* ITS_PARAMETER_VALUE: #1600 [100]
* PARAMETER_NAME: #1600 ['PROFILE LENGTH']
*/
#1600=MEASURE_REPRESENTATION_ITEM('PROFILE LENGTH',NUMERIC_MEASURE(100.),
#1601);
#1601=(
LENGTH_UNIT()
NAMED_UNIT(*)
SI_UNIT(.MILLI.,.METRE.)
);

/*****
* Application object: LINEAR_PROFILE (#1700)
* PROFILE_LENGTH: #1700, #1701, #1702, #1703, #1600
*/
#1700=LINEAR_PROFILE('','',#1509,.F.);
#1701=PROPERTY_DEFINITION('profile length','',#1700);
#1702=SHAPE_DEFINITION_REPRESENTATION(#1701,#1703);
#1703=SHAPE_REPRESENTATION_WITH_PARAMETERS('',( #1600),#427);

/*****

```

ISO 10303-238:2007(E)

```

* Application object: PLANAR_FACE (#1800)
* FEATURE_PLACEMENT: #1800, #1801, #1802, #1803, #1804
* COURSE_OF_TRAVEL: #1800, #1801, #1805, #1806, #1500
* REMOVAL_DEPTH: #1800, #1801, #1802, #1803, #1807
* ITS_WORKPIECE: #1800, #401, #400
* DEPTH: #1800, #1801, #1808, #1809, #1810
* REMOVAL_BOUNDARY: #1800, #1801, #1811, #1812, #1700
* ITS_ID: #1800 ['PLANAR_FACE1']
*/
#1800=(
CHARACTERIZED_OBJECT('','')
FEATURE_DEFINITION()
FLAT_FACE()
INSTANCED_FEATURE()
SHAPE_ASPECT('PLANAR_FACE1','',#401,.T.)
);
#1801=PRODUCT_DEFINITION_SHAPE('','',#1800);
#1802=SHAPE_DEFINITION_REPRESENTATION(#1801,#1803);
#1803=SHAPE_REPRESENTATION_WITH_PARAMETERS('',( #1804,#1807),#427);
#1804=AXIS2_PLACEMENT_3D('orientation',#1813,#1814,#1815);
#1805=SHAPE_ASPECT('','course of travel occurrence',#1801,.F.);
#1806=SHAPE_DEFINING_RELATIONSHIP('course of travel',
'path feature component usage',#1500,#1805);
#1807=(
LENGTH_MEASURE_WITH_UNIT()
MEASURE_REPRESENTATION_ITEM()
MEASURE_WITH_UNIT($,#1601)
REPRESENTATION_ITEM('removal depth')
);
#1808=SHAPE_DEFINITION_REPRESENTATION(#1801,#1809);
#1809=SHAPE_REPRESENTATION('maximum feature limit',(#1810),#427);
#1810=PLANE('PLANAR_FACE1-DEPTH PLANE',#1816);
#1811=SHAPE_ASPECT('','removal boundary occurrence',#1801,.F.);
#1812=SHAPE_DEFINING_RELATIONSHIP('removal boundary','profile usage',#1700,
#1811);
#1813=CARTESIAN_POINT('PLANAR_FACE1:LOCATION ',(0.,0.,5.));
#1814=DIRECTION(' AXIS ',(0.,0.,1.));
#1815=DIRECTION(' REF_DIRECTION',(1.,0.,0.));
#1816=AXIS2_PLACEMENT_3D('PLANAR_FACE1',#1817,#1818,#1819);
#1817=CARTESIAN_POINT('PLANAR_FACE1:DEPTH ',(0.,0.,-5.));
#1818=DIRECTION(' AXIS ',(0.,0.,1.));
#1819=DIRECTION(' REF_DIRECTION',(1.,0.,0.));

/*****
* Application object: MACHINING_WORKINGSTEP (#1900)
* ITS_OPERATION: #1900, #1901, #1300
* ITS_FEATURE: #1900, #1902, #1903, #1904, #1905, #1800
* ITS_SECPANE: #1900, #1906, #1907, #1908, #1909
* ITS_ID: #1900 ['WS_FINISH_PLANAR_FACE1']
*/
#1900=MACHINING_WORKINGSTEP('WS_FINISH_PLANAR_FACE1','machining','',');
#1901=MACHINING_OPERATION_RELATIONSHIP('','machining',#1900,#1300);
#1902=MACHINING_FEATURE_RELATIONSHIP('','machining',#1900,#1903);
#1903=MACHINING_FEATURE_PROCESS('','machining','',');

```

```

#1904=PROPERTY_PROCESS('machining','machining',#1903,'');
#1905=PROCESS_PROPERTY_ASSOCIATION('','machining',#1904,#1800);
#1906=ACTION_PROPERTY('security plane','machining',#1900);
#1907=ACTION_PROPERTY_REPRESENTATION('','machining',#1906,#1908);
#1908=REPRESENTATION('',( #1909),#505);
#1909=PLANE('SECURITY PLANE',#1910);
#1910=AXIS2_PLACEMENT_3D('PLANE1',#1911,#1912,#1913);
#1911=CARTESIAN_POINT('SECPLANE1: LOCATION ',(0.,0.,30.));
#1912=DIRECTION(' AXIS ',(0.,0.,1.));
#1913=DIRECTION(' REF_DIRECTION',(1.,0.,0.));

/*****
* Application object: DRILLING_CUTTING_TOOL (#2000)
* ITS_ID: #2000 ['DRILL 20MM']
* OVERALL_ASSEMBLY_LENGTH: #2000, #2005, #2006, #2100, #2104
* EFFECTIVE_CUTTING_DIAMETER: #2000, #2005, #2006, #2100, #2105
* MAXIMUM_DEPTH_OF_CUT: #2000, #2005, #2006, #2100, #2106
* HAND_OF_CUT: #2000, #2005, #2006, #2100, #2102 ['right']
* COOLANT_THROUGH_TOOL: #2000, #2005, #2006, #2100, #2103 ['not supported']
* POINT_ANGLE: #2000, #2005, #2006, #2100, #2107
*/
#2000=MACHINING_TOOL('DRILL 20MM','drill',(#2500),#2007);
#2005=RESOURCE_PROPERTY('tool body','',#2000);
#2006=RESOURCE_PROPERTY_REPRESENTATION('','',#2005,#2100);
#2007=ACTION_RESOURCE_TYPE('milling cutting tool');

#2100=MACHINING_TOOL_BODY_REPRESENTATION('drill', (#2102,
#2103,#2104,#2105,#2106,#2107),#505);
#2102=DESCRIPTIVE_REPRESENTATION_ITEM('hand of cut','right');
#2103=DESCRIPTIVE_REPRESENTATION_ITEM('coolant through tool',
'not supported');
#2104=(
LENGTH_MEASURE_WITH_UNIT()
MEASURE_REPRESENTATION_ITEM()
MEASURE_WITH_UNIT(LENGTH_MEASURE(90.),#1601)
REPRESENTATION_ITEM('overall assembly length')
);
#2105=(
LENGTH_MEASURE_WITH_UNIT()
MEASURE_REPRESENTATION_ITEM()
MEASURE_WITH_UNIT(LENGTH_MEASURE(20.),#1601)
REPRESENTATION_ITEM('effective cutting diameter')
);
#2106=(
LENGTH_MEASURE_WITH_UNIT()
MEASURE_REPRESENTATION_ITEM()
MEASURE_WITH_UNIT(LENGTH_MEASURE(70.),#1601)
REPRESENTATION_ITEM('maximum depth of cut')
);
#2107=(
MEASURE_REPRESENTATION_ITEM()
MEASURE_WITH_UNIT(PLANE_ANGLE_MEASURE(120.),#428)
PLANE_ANGLE_MEASURE_WITH_UNIT()
REPRESENTATION_ITEM('point angle')

```

);

```

/*****
* Application object: MILLING_TECHNOLOGY (#2300)
* SYNCHRONIZE_SPINDLE_WITH_FEED: #2300, #2301, #2302, #2303, #2304 ['not
synchronized']
* FEEDRATE_PER_TOOTH: #2300, #2305, #2306, #2307, #2308
* SPINDLE: #2300, #2309, #2310, #2311, #2312
* CUTSPEED: #2300, #2313, #2314, #2315, #2316
* INHIBIT_FEEDRATE_OVERRIDE: #2300, #2317, #2318, #2319, #2320 ['override not
allowed']
* FEEDRATE: #2300, #2321, #2322, #2323, #2324
* FEEDRATE_REFERENCE: #2300, #2325, #2326, #2327, #2328 ['tool center point']
* INHIBIT_SPINDLE_OVERRIDE: #2300, #2329, #2330, #2331, #2332 ['override not
allowed']
*/
#2300=MACHINING_TECHNOLOGY('', 'milling', '', '');
#2301=ACTION_PROPERTY('synchronize spindle with feed', 'milling', #2300);
#2302=ACTION_PROPERTY_REPRESENTATION('', 'milling', #2301, #2303);
#2303=REPRESENTATION('', (#2304), #505);
#2304=DESCRIPTIVE_REPRESENTATION_ITEM('', 'not synchronized');
#2305=ACTION_PROPERTY('feedrate', 'milling', #2300);
#2306=ACTION_PROPERTY_REPRESENTATION('feed per tooth', 'milling', #2305, #2307);
#2307=MACHINING_FEED_SPEED_REPRESENTATION('feed per tooth', (#2308), #505);
#2308=MEASURE_REPRESENTATION_ITEM('feed per tooth', $, #833);
#2309=ACTION_PROPERTY('spindle', 'milling', #2300);
#2310=ACTION_PROPERTY_REPRESENTATION('rotational speed', 'milling', #2309,
#2311);
#2311=MACHINING_SPINDLE_SPEED_REPRESENTATION('spindle speed', (#2312), #505);
#2312=MEASURE_REPRESENTATION_ITEM('rotational speed', NUMERIC_MEASURE(16.),
#837);
#2313=ACTION_PROPERTY('spindle', 'milling', #2300);
#2314=ACTION_PROPERTY_REPRESENTATION('surface speed', 'milling', #2313, #2315);
#2315=MACHINING_SPINDLE_SPEED_REPRESENTATION('cutting speed', (#2316), #505);
#2316=MEASURE_REPRESENTATION_ITEM('surface speed', $, #837);
#2317=ACTION_PROPERTY('inhibit feedrate override', 'milling', #2300);
#2318=ACTION_PROPERTY_REPRESENTATION('', 'milling', #2317, #2319);
#2319=REPRESENTATION('', (#2320), #505);
#2320=DESCRIPTIVE_REPRESENTATION_ITEM('', 'override not allowed');
#2321=ACTION_PROPERTY('feedrate', 'milling', #2300);
#2322=ACTION_PROPERTY_REPRESENTATION('feed speed', 'milling', #2321, #2323);
#2323=MACHINING_FEED_SPEED_REPRESENTATION('feed speed', (#2324), #505);
#2324=MEASURE_REPRESENTATION_ITEM('feed speed', NUMERIC_MEASURE(0.03), #833);
#2325=ACTION_PROPERTY('feedrate reference', 'milling', #2300);
#2326=ACTION_PROPERTY_REPRESENTATION('', 'milling', #2325, #2327);
#2327=REPRESENTATION('', (#2328), #505);
#2328=DESCRIPTIVE_REPRESENTATION_ITEM('', 'tool center point');
#2329=ACTION_PROPERTY('inhibit spindle override', 'milling', #2300);
#2330=ACTION_PROPERTY_REPRESENTATION('', 'milling', #2329, #2331);
#2331=REPRESENTATION('', (#2332), #505);
#2332=DESCRIPTIVE_REPRESENTATION_ITEM('', 'override not allowed');

/*****

```

```

* Application object: DRILLING_TYPE_STRATEGY (#2400)
* REDUCED_CUT_AT_END: #2400, #2401, #2402, #2403, #2404
* REDUCED_CUT_AT_START: #2400, #2405, #2406, #2407, #2408
* DEPTH_OF_END: #2400, #2409, #2410, #2411, #2412
* REDUCED_FEED_AT_END: #2400, #2413, #2414, #2415, #2416
* DEPTH_OF_START: #2400, #2417, #2418, #2419, #2420
* REDUCED_FEED_AT_START: #2400, #2421, #2422, #2423, #2424
*/
#2400=DRILLING_TYPE_STRATEGY('', '', '', '');
#2401=ACTION_PROPERTY('reduced cut at end', '', #2400);
#2402=ACTION_PROPERTY_REPRESENTATION('relative speed', '', #2401, #2403);
#2403=MACHINING_SPINDLE_SPEED_REPRESENTATION('relative speed', (#2404), #505);
#2404= (
MEASURE_REPRESENTATION_ITEM()
MEASURE_WITH_UNIT(RATIO_MEASURE(50.), #1217)
RATIO_MEASURE_WITH_UNIT()
REPRESENTATION_ITEM('relative speed')
);
#2405=ACTION_PROPERTY('reduced cut at start', '', #2400);
#2406=ACTION_PROPERTY_REPRESENTATION('relative speed', '', #2405, #2407);
#2407=MACHINING_SPINDLE_SPEED_REPRESENTATION('relative speed', (#2408), #505);
#2408= (
MEASURE_REPRESENTATION_ITEM()
MEASURE_WITH_UNIT(RATIO_MEASURE(75.), #1217)
RATIO_MEASURE_WITH_UNIT()
REPRESENTATION_ITEM('relative speed')
);
#2409=ACTION_PROPERTY('depth of end', '', #2400);
#2410=ACTION_PROPERTY_REPRESENTATION('', '', #2409, #2411);
#2411=REPRESENTATION('', (#2412), #505);
#2412= (
LENGTH_MEASURE_WITH_UNIT()
MEASURE_REPRESENTATION_ITEM()
MEASURE_WITH_UNIT(LENGTH_MEASURE(8.), #1601)
REPRESENTATION_ITEM('')
);
#2413=ACTION_PROPERTY('reduced feedrate at end', '', #2400);
#2414=ACTION_PROPERTY_REPRESENTATION('relative speed', '', #2413, #2415);
#2415=MACHINING_FEED_SPEED_REPRESENTATION('relative speed', (#2416), #505);
#2416= (
MEASURE_REPRESENTATION_ITEM()
MEASURE_WITH_UNIT(RATIO_MEASURE(75.), #1217)
RATIO_MEASURE_WITH_UNIT()
REPRESENTATION_ITEM('relative speed')
);
#2417=ACTION_PROPERTY('depth of start', '', #2400);
#2418=ACTION_PROPERTY_REPRESENTATION('', '', #2417, #2419);
#2419=REPRESENTATION('', (#2420), #505);
#2420= (
LENGTH_MEASURE_WITH_UNIT()
MEASURE_REPRESENTATION_ITEM()
MEASURE_WITH_UNIT(LENGTH_MEASURE(2.), #1601)
REPRESENTATION_ITEM('')
);

```

```

#2421=ACTION_PROPERTY('reduced feedrate at start','',#2400);
#2422=ACTION_PROPERTY_REPRESENTATION('relative speed','',#2421,#2423);
#2423=MACHINING_FEED_SPEED_REPRESENTATION('relative speed',(#2424),#505);
#2424=(
MEASURE_REPRESENTATION_ITEM()
MEASURE_WITH_UNIT(RATIO_MEASURE(50.),#1217)
RATIO_MEASURE_WITH_UNIT()
REPRESENTATION_ITEM('relative speed')
);

/*****
* Application object: DRILLING (#2500)
* RETRACT_PLANE: #2500, #2501, #2502, #2503, #2504
* ITS_TECHNOLOGY: #2500, #2505, #2300
* ITS_ID: #2500 ['DRILL HOLE1']
* ITS_TOOL: #2500, #2000
* CUTTING_DEPTH: #2500, #2506, #2507, #2508, #2509
* PREVIOUS_DIAMETER: #2500, #2510, #2511, #2512, #2513
* OVERCUT_LENGTH: #2500, #2514, #2515, #2516, #2517
* FEED_ON_RETRACT: #2500, #2518, #2519, #2520, #2521
* ITS_MACHINING_STRATEGY: #2500, #2522, #2400
* ITS_MACHINE_FUNCTIONS: #2500, #2523, #900
*/
#2500=DRILLING_OPERATION('DRILL HOLE1','drilling','',');
#2501=ACTION_PROPERTY('retract plane','drilling',#2500);
#2502=ACTION_PROPERTY_REPRESENTATION('','drilling',#2501,#2503);
#2503=REPRESENTATION('',( #2504),#505);
#2504=(
LENGTH_MEASURE_WITH_UNIT()
MEASURE_REPRESENTATION_ITEM()
MEASURE_WITH_UNIT(LENGTH_MEASURE(10.),#1601)
REPRESENTATION_ITEM('')
);
#2505=MACHINING_TECHNOLOGY_RELATIONSHIP('','drilling',#2500,#2300);
#2506=ACTION_PROPERTY('cutting depth','drilling',#2500);
#2507=ACTION_PROPERTY_REPRESENTATION('','drilling',#2506,#2508);
#2508=REPRESENTATION('',( #2509),#505);
#2509=(
LENGTH_MEASURE_WITH_UNIT()
MEASURE_REPRESENTATION_ITEM()
MEASURE_WITH_UNIT(LENGTH_MEASURE(30.),#1601)
REPRESENTATION_ITEM('')
);
#2510=ACTION_PROPERTY('previous diameter','drilling',#2500);
#2511=ACTION_PROPERTY_REPRESENTATION('','drilling',#2510,#2512);
#2512=REPRESENTATION('',( #2513),#505);
#2513=(
LENGTH_MEASURE_WITH_UNIT()
MEASURE_REPRESENTATION_ITEM()
MEASURE_WITH_UNIT(LENGTH_MEASURE(0.),#1601)
REPRESENTATION_ITEM('')
);
#2514=ACTION_PROPERTY('overcut length','drilling',#2500);
#2515=ACTION_PROPERTY_REPRESENTATION('','drilling',#2514,#2516);

```

```

#2516=REPRESENTATION('', (#2517), #505);
#2517=(
LENGTH_MEASURE_WITH_UNIT()
MEASURE_REPRESENTATION_ITEM()
MEASURE_WITH_UNIT($, #1601)
REPRESENTATION_ITEM('')
);
#2518=ACTION_PROPERTY('feedrate on retract', 'drilling', #2500);
#2519=ACTION_PROPERTY_REPRESENTATION('relative speed', 'drilling', #2518, #2520);
#2520=MACHINING_FEED_SPEED_REPRESENTATION('relative speed', (#2521), #505);
#2521=(
MEASURE_REPRESENTATION_ITEM()
MEASURE_WITH_UNIT(RATIO_MEASURE(0.), #1217)
RATIO_MEASURE_WITH_UNIT()
REPRESENTATION_ITEM('relative speed')
);
#2522=MACHINING_STRATEGY_RELATIONSHIP('machining', 'drilling', #2500, #2400);
#2523=MACHINING_FUNCTIONS_RELATIONSHIP('', 'drilling', #2500, #900);

/*****
* Application object: REAMING_CUTTING_TOOL (#2600)
* ITS_ID: #2600 ['REAMER 22MM']
* ITS_CUTTING_EDGE [*]: #2600, #2601, #500
* ITS_CUTTING_EDGE [*]: #2600, #2602, #500
* ITS_CUTTING_EDGE [*]: #2600, #2603, #500
* ITS_CUTTING_EDGE [*]: #2600, #2604, #500
* OVERALL_ASSEMBLY_LENGTH: #2600, #2605, #2606, #2700, #2703
* EFFECTIVE_CUTTING_DIAMETER: #2600, #2605, #2606, #2700, #2704
* MAXIMUM_DEPTH_OF_CUT: #2600, #2605, #2606, #2700, #2705
* HAND_OF_CUT: #2600, #2605, #2606, #2700, #2701 ['right']
* COOLANT_THROUGH_TOOL: #2600, #2605, #2606, #2700, #2702 ['not supported']
*/
#2600=MACHINING_TOOL('REAMER 22MM', 'reamer', (#3000), #2607);
#2601=ACTION_RESOURCE_RELATIONSHIP('', '#2600, #500);
#2602=ACTION_RESOURCE_RELATIONSHIP('', '#2600, #500);
#2603=ACTION_RESOURCE_RELATIONSHIP('', '#2600, #500);
#2604=ACTION_RESOURCE_RELATIONSHIP('', '#2600, #500);
#2605=RESOURCE_PROPERTY('tool body', '#2600);
#2606=RESOURCE_PROPERTY_REPRESENTATION('', '#2605, #2700);
#2607=ACTION_RESOURCE_TYPE('milling cutting tool');

#2700=MACHINING_TOOL_BODY_REPRESENTATION('reamer', (#2701, #2702, #2703,
#2704, #2705), #505);
#2701=DESCRIPTIVE_REPRESENTATION_ITEM('hand of cut', 'right');
#2702=DESCRIPTIVE_REPRESENTATION_ITEM('coolant through tool',
'not supported');
#2703=(
LENGTH_MEASURE_WITH_UNIT()
MEASURE_REPRESENTATION_ITEM()
MEASURE_WITH_UNIT(LENGTH_MEASURE(100.), #1601)
REPRESENTATION_ITEM('overall assembly length')
);
#2704=(
LENGTH_MEASURE_WITH_UNIT()

```

```

MEASURE_REPRESENTATION_ITEM()
MEASURE_WITH_UNIT(LENGTH_MEASURE(22.),#1601)
REPRESENTATION_ITEM('effective cutting diameter')
);
#2705=(
LENGTH_MEASURE_WITH_UNIT()
MEASURE_REPRESENTATION_ITEM()
MEASURE_WITH_UNIT(LENGTH_MEASURE(60.),#1601)
REPRESENTATION_ITEM('maximum depth of cut')
);

/*****
* Application object: MILLING_TECHNOLOGY (#2800)
* SYNCHRONIZE_SPINDLE_WITH_FEED: #2800, #2801, #2802, #2803, #2804 ['not
synchronized']
* FEEDRATE_PER_TOOTH: #2800, #2805, #2806, #2807, #2808
* SPINDLE: #2800, #2809, #2810, #2811, #2812
* CUTSPEED: #2800, #2813, #2814, #2815, #2816
* INHIBIT_FEEDRATE_OVERRIDE: #2800, #2817, #2818, #2819, #2820 ['override not
allowed']
* FEEDRATE: #2800, #2821, #2822, #2823, #2824
* FEEDRATE_REFERENCE: #2800, #2825, #2826, #2827, #2828 ['tool center point']
* INHIBIT_SPINDLE_OVERRIDE: #2800, #2829, #2830, #2831, #2832 ['override not
allowed']
*/
#2800=MACHINING_TECHNOLOGY('','milling','','');
#2801=ACTION_PROPERTY('synchronize spindle with feed','milling',#2800);
#2802=ACTION_PROPERTY_REPRESENTATION('','milling',#2801,#2803);
#2803=REPRESENTATION('',( #2804),#505);
#2804=DESCRIPTIVE_REPRESENTATION_ITEM('','not synchronized');
#2805=ACTION_PROPERTY('feedrate','milling',#2800);
#2806=ACTION_PROPERTY_REPRESENTATION('feed per tooth','milling',#2805,#2807);
#2807=MACHINING_FEED_SPEED_REPRESENTATION('feed per tooth',( #2808),#505);
#2808=MEASURE_REPRESENTATION_ITEM('feed per tooth',$,#833);
#2809=ACTION_PROPERTY('spindle','milling',#2800);
#2810=ACTION_PROPERTY_REPRESENTATION('rotational speed','milling',#2809,
#2811);
#2811=MACHINING_SPINDLE_SPEED_REPRESENTATION('spindle speed',( #2812),#505);
#2812=MEASURE_REPRESENTATION_ITEM('rotational speed',NUMERIC_MEASURE(18.),
#837);
#2813=ACTION_PROPERTY('spindle','milling',#2800);
#2814=ACTION_PROPERTY_REPRESENTATION('surface speed','milling',#2813,#2815);
#2815=MACHINING_SPINDLE_SPEED_REPRESENTATION('cutting speed',( #2816),#505);
#2816=MEASURE_REPRESENTATION_ITEM('surface speed',$,#837);
#2817=ACTION_PROPERTY('inhibit feedrate override','milling',#2800);
#2818=ACTION_PROPERTY_REPRESENTATION('','milling',#2817,#2819);
#2819=REPRESENTATION('',( #2820),#505);
#2820=DESCRIPTIVE_REPRESENTATION_ITEM('','override not allowed');
#2821=ACTION_PROPERTY('feedrate','milling',#2800);
#2822=ACTION_PROPERTY_REPRESENTATION('feed speed','milling',#2821,#2823);
#2823=MACHINING_FEED_SPEED_REPRESENTATION('feed speed',( #2824),#505);
#2824=MEASURE_REPRESENTATION_ITEM('feed speed',NUMERIC_MEASURE(0.03),#833);
#2825=ACTION_PROPERTY('feedrate reference','milling',#2800);
#2826=ACTION_PROPERTY_REPRESENTATION('','milling',#2825,#2827);

```



```

#2827=REPRESENTATION('',( #2828), #505);
#2828=DESCRIPTIVE_REPRESENTATION_ITEM('','tool center point');
#2829=ACTION_PROPERTY('inhibit spindle override','milling', #2800);
#2830=ACTION_PROPERTY_REPRESENTATION('','milling', #2829, #2831);
#2831=REPRESENTATION('',( #2832), #505);
#2832=DESCRIPTIVE_REPRESENTATION_ITEM('','override not allowed');

/*****
* Application object: DRILLING_TYPE_STRATEGY (#2900)
* REDUCED_CUT_AT_END: #2900, #2901, #2902, #2903, #2904
* REDUCED_CUT_AT_START: #2900, #2905, #2906, #2907, #2908
* DEPTH_OF_END: #2900, #2909, #2910, #2911, #2912
* REDUCED_FEED_AT_END: #2900, #2913, #2914, #2915, #2916
* DEPTH_OF_START: #2900, #2917, #2918, #2919, #2920
* REDUCED_FEED_AT_START: #2900, #2921, #2922, #2923, #2924
*/
#2900=DRILLING_TYPE_STRATEGY('','','');
#2901=ACTION_PROPERTY('reduced cut at end','', #2900);
#2902=ACTION_PROPERTY_REPRESENTATION('relative speed','', #2901, #2903);
#2903=MACHINING_SPINDLE_SPEED_REPRESENTATION('relative speed', (#2904), #505);
#2904=(
MEASURE_REPRESENTATION_ITEM()
MEASURE_WITH_UNIT($, #1217)
RATIO_MEASURE_WITH_UNIT()
REPRESENTATION_ITEM('relative speed')
);
#2905=ACTION_PROPERTY('reduced cut at start','', #2900);
#2906=ACTION_PROPERTY_REPRESENTATION('relative speed','', #2905, #2907);
#2907=MACHINING_SPINDLE_SPEED_REPRESENTATION('relative speed', (#2908), #505);
#2908=(
MEASURE_REPRESENTATION_ITEM()
MEASURE_WITH_UNIT($, #1217)
RATIO_MEASURE_WITH_UNIT()
REPRESENTATION_ITEM('relative speed')
);
#2909=ACTION_PROPERTY('depth of end','', #2900);
#2910=ACTION_PROPERTY_REPRESENTATION('','', #2909, #2911);
#2911=REPRESENTATION('',( #2912), #505);
#2912=(
LENGTH_MEASURE_WITH_UNIT()
MEASURE_REPRESENTATION_ITEM()
MEASURE_WITH_UNIT($, #1601)
REPRESENTATION_ITEM('')
);
#2913=ACTION_PROPERTY('reduced feedrate at end','', #2900);
#2914=ACTION_PROPERTY_REPRESENTATION('relative speed','', #2913, #2915);
#2915=MACHINING_FEED_SPEED_REPRESENTATION('relative speed', (#2916), #505);
#2916=(
MEASURE_REPRESENTATION_ITEM()
MEASURE_WITH_UNIT($, #1217)
RATIO_MEASURE_WITH_UNIT()
REPRESENTATION_ITEM('relative speed')
);
#2917=ACTION_PROPERTY('depth of start','', #2900);

```

ISO 10303-238:2007(E)

```

#2918=ACTION_PROPERTY_REPRESENTATION('','',#2917,#2919);
#2919=REPRESENTATION('',( #2920),#505);
#2920=(
LENGTH_MEASURE_WITH_UNIT()
MEASURE_REPRESENTATION_ITEM()
MEASURE_WITH_UNIT($,#1601)
REPRESENTATION_ITEM('')
);
#2921=ACTION_PROPERTY('reduced feedrate at start','',#2900);
#2922=ACTION_PROPERTY_REPRESENTATION('relative speed','',#2921,#2923);
#2923=MACHINING_FEED_SPEED_REPRESENTATION('relative speed',( #2924),#505);
#2924=(
MEASURE_REPRESENTATION_ITEM()
MEASURE_WITH_UNIT($,#1217)
RATIO_MEASURE_WITH_UNIT()
REPRESENTATION_ITEM('relative speed')
);

/*****
* Application object: REAMING (#3000)
* ITS_MACHINE_FUNCTIONS: #3000, #3001, #900
* RETRACT_PLANE: #3000, #3002, #3003, #3004, #3005
* ITS_TOOL: #3000, #2600
* FEED_ON_RETRACT: #3000, #3006, #3007, #3008, #3009
* PREVIOUS_DIAMETER: #3000, #3010, #3011, #3012, #3013
* ITS_MACHINING_STRATEGY: #3000, #3014, #2900
* ITS_ID: #3000 ['REAM HOLE1']
* ITS_TECHNOLOGY: #3000, #3015, #2800
* OVERCUT_LENGTH: #3000, #3016, #3017, #3018, #3019
* CUTTING_DEPTH: #3000, #3020, #3021, #3022, #3023
* DEPTH_OF_TESTCUT: #3000, #3024, #3025, #3026, #3027
*/
#3000=BORING_OPERATION('REAM HOLE1','reaming','','');
#3001=MACHINING_FUNCTIONS_RELATIONSHIP('','reaming',#3000,#900);
#3002=ACTION_PROPERTY('retract plane','reaming',#3000);
#3003=ACTION_PROPERTY_REPRESENTATION('','reaming',#3002,#3004);
#3004=REPRESENTATION('',( #3005),#505);
#3005=(
LENGTH_MEASURE_WITH_UNIT()
MEASURE_REPRESENTATION_ITEM()
MEASURE_WITH_UNIT(LENGTH_MEASURE(10.),#1601)
REPRESENTATION_ITEM('')
);
#3006=ACTION_PROPERTY('feedrate on retract','reaming',#3000);
#3007=ACTION_PROPERTY_REPRESENTATION('relative speed','reaming',#3006,#3008);
#3008=MACHINING_FEED_SPEED_REPRESENTATION('relative speed',( #3009),#505);
#3009=(
MEASURE_REPRESENTATION_ITEM()
MEASURE_WITH_UNIT(RATIO_MEASURE(1.),#1217)
RATIO_MEASURE_WITH_UNIT()
REPRESENTATION_ITEM('relative speed')
);
#3010=ACTION_PROPERTY('previous diameter','reaming',#3000);
#3011=ACTION_PROPERTY_REPRESENTATION('','reaming',#3010,#3012);

```

```

#3012=REPRESENTATION('', (#3013), #505);
#3013= (
LENGTH_MEASURE_WITH_UNIT()
MEASURE_REPRESENTATION_ITEM()
MEASURE_WITH_UNIT(LENGTH_MEASURE(20.), #1601)
REPRESENTATION_ITEM('')
);
#3014=MACHINING_STRATEGY_RELATIONSHIP('machining', 'reaming', #3000, #2900);
#3015=MACHINING_TECHNOLOGY_RELATIONSHIP('', 'reaming', #3000, #2800);
#3016=ACTION_PROPERTY('overcut length', 'reaming', #3000);
#3017=ACTION_PROPERTY_REPRESENTATION('', 'reaming', #3016, #3018);
#3018=REPRESENTATION('', (#3019), #505);
#3019= (
LENGTH_MEASURE_WITH_UNIT()
MEASURE_REPRESENTATION_ITEM()
MEASURE_WITH_UNIT($, #1601)
REPRESENTATION_ITEM('')
);
#3020=ACTION_PROPERTY('cutting depth', 'reaming', #3000);
#3021=ACTION_PROPERTY_REPRESENTATION('', 'reaming', #3020, #3022);
#3022=REPRESENTATION('', (#3023), #505);
#3023= (
LENGTH_MEASURE_WITH_UNIT()
MEASURE_REPRESENTATION_ITEM()
MEASURE_WITH_UNIT(LENGTH_MEASURE(30.), #1601)
REPRESENTATION_ITEM('')
);
#3024=ACTION_PROPERTY('testcut depth', 'reaming', #3000);
#3025=ACTION_PROPERTY_REPRESENTATION('', 'reaming', #3024, #3026);
#3026=REPRESENTATION('', (#3027), #505);
#3027= (
LENGTH_MEASURE_WITH_UNIT()
MEASURE_REPRESENTATION_ITEM()
MEASURE_WITH_UNIT(LENGTH_MEASURE(5.), #1601)
REPRESENTATION_ITEM('')
);

/*****
* Application object: TOLERANCED_LENGTH_MEASURE (#3100)
* VALUE_COMPONENT: #3100 [22]
*****
* Application object: QUALIFIED_PLUS_MINUS_VALUE (#3100)
*/
#3100= (
LENGTH_MEASURE_WITH_UNIT()
MEASURE_REPRESENTATION_ITEM()
MEASURE_WITH_UNIT(LENGTH_MEASURE(22.), #1601)
QUALIFIED_REPRESENTATION_ITEM($)
REPRESENTATION_ITEM('diameter')
);

/*****
* Application object: THROUGH_BOTTOM_CONDITION (#3200)
*/

```

```

#3200=HOLE_BOTTOM('', 'through', #1509, .F.);

/*****
* Application object: ROUND_HOLE (#3300)
* ITS_WORKPIECE: #3300, #401, #400
* ITS_ID: #3300 ['HOLE1 D=22MM']
* COURSE_OF_TRAVEL: #3300, #3301, #3302, #3303, #3500
* FEATURE_PLACEMENT: #3300, #3301, #3304, #3305, #3306
* DEPTH: #3300, #3301, #3307, #3308, #3309
* DIAMETER: #3300, #3301, #3310, #3311, #3400
* BOTTOM_CONDITION: #3300, #3301, #3312, #3313, #3200
*/
#3300=(
CHARACTERIZED_OBJECT('', '')
FEATURE_DEFINITION()
INSTANCED_FEATURE()
ROUND_HOLE()
SHAPE_ASPECT('HOLE1 D=22MM', '', #401, .T.)
);
#3301=PRODUCT_DEFINITION_SHAPE('', '', #3300);
#3302=SHAPE_ASPECT('', 'hole depth occurrence', #3301, .F.);
#3303=SHAPE_DEFINING_RELATIONSHIP('hole depth',
'path feature component usage', #3500, #3302);
#3304=SHAPE_DEFINITION_REPRESENTATION(#3301, #3305);
#3305=SHAPE_REPRESENTATION_WITH_PARAMETERS('', (#3306), #427);
#3306=AXIS2_PLACEMENT_3D('orientation', #3314, #3507, $);
#3307=SHAPE_DEFINITION_REPRESENTATION(#3301, #3308);
#3308=SHAPE_REPRESENTATION('maximum feature limit', (#3309), #427);
#3309=PLANE('DEPTH SURFACE FOR ROUND HOLE1', #3315);
#3310=SHAPE_ASPECT('', 'diameter occurrence', #3301, .F.);
#3311=SHAPE_DEFINING_RELATIONSHIP('diameter', 'profile usage', #3400, #3310);
#3312=SHAPE_ASPECT('', 'bottom condition occurrence', #3301, .F.);
#3313=FEATURE_COMPONENT_RELATIONSHIP('', 'hole bottom usage', #3200, #3312);
#3314=CARTESIAN_POINT('HOLE1: LOCATION ', (20., 60., 0.));
#3315=AXIS2_PLACEMENT_3D('HOLE1', #3316, #3317, #3318);
#3316=CARTESIAN_POINT('HOLE1: DEPTH ', (0., 0., -30.));
#3317=DIRECTION(' AXIS ', (0., 0., 1.));
#3318=DIRECTION(' REF_DIRECTION', (1., 0., 0.));

/*****
* Application object: CIRCULAR_CLOSED_PROFILE (#3400)
* PLACEMENT: #3400, #3401, #3402, #3403, #3306
* DIAMETER: #3400, #3401, #3402, #3403, #3100
*/
#3400=CIRCULAR_CLOSED_PROFILE('', '', #1509, .F.);
#3401=PROPERTY_DEFINITION('', '', #3400);
#3402=SHAPE_DEFINITION_REPRESENTATION(#3401, #3403);
#3403=SHAPE_REPRESENTATION_WITH_PARAMETERS('', (#3100, #3306), #427);

/*****
* Application object: LINEAR_PATH (#3500)
* PLACEMENT: #3500, #3501, #3502, #3503, #3306
* ITS_DIRECTION: #3500, #3504, #3505, #3506, #3507
* DISTANCE: #3500, #3501, #3502, #3503, #3508

```

```

*/
#3500=PATH_FEATURE_COMPONENT('', 'linear', #1509, .F.);
#3501=PROPERTY_DEFINITION('', 'linear', #3500);
#3502=SHAPE_DEFINITION_REPRESENTATION(#3501, #3503);
#3503=SHAPE_REPRESENTATION_WITH_PARAMETERS('', (#3508, #3306), #427);
#3504=PROPERTY_DEFINITION('', 'linear', #3500);
#3505=PROPERTY_DEFINITION_REPRESENTATION(#3504, #3506);
#3506=DIRECTION_SHAPE_REPRESENTATION('', (#3507), #505);
#3507=DIRECTION(' AXIS ', (0., 0., 1.));
#3508=(
LENGTH_MEASURE_WITH_UNIT()
MEASURE_REPRESENTATION_ITEM()
MEASURE_WITH_UNIT(LENGTH_MEASURE(30.), #1601)
REPRESENTATION_ITEM('distance')
);

/*****
* Application object: MACHINING_WORKINGSTEP (#3600)
* ITS_OPERATION: #3600, #3601, #2500
* ITS_FEATURE: #3600, #3602, #3603, #3604, #3605, #3300
* ITS_SECPANE: #3600, #3606, #3607, #3608, #1909
* ITS_ID: #3600 ['WS DRILL HOLE1']
*/
#3600=MACHINING_WORKINGSTEP('WS DRILL HOLE1', 'machining', '', '');
#3601=MACHINING_OPERATION_RELATIONSHIP('', 'machining', #3600, #2500);
#3602=MACHINING_FEATURE_RELATIONSHIP('', 'machining', #3600, #3603);
#3603=MACHINING_FEATURE_PROCESS('', 'machining', '', '');
#3604=PROPERTY_PROCESS('machining', 'machining', #3603, '');
#3605=PROCESS_PROPERTY_ASSOCIATION('', 'machining', #3604, #3300);
#3606=ACTION_PROPERTY('security plane', 'machining', #3600);
#3607=ACTION_PROPERTY_REPRESENTATION('', 'machining', #3606, #3608);
#3608=REPRESENTATION('', (#1909), #505);

/*****
* Application object: MACHINING_WORKINGSTEP (#3700)
* ITS_OPERATION: #3700, #3701, #3000
* ITS_FEATURE: #3700, #3702, #3703, #3704, #3705, #3300
* ITS_SECPANE: #3700, #3706, #3707, #3708, #1909
* ITS_ID: #3700 ['WS REAM HOLE1']
*/
#3700=MACHINING_WORKINGSTEP('WS REAM HOLE1', 'machining', '', '');
#3701=MACHINING_OPERATION_RELATIONSHIP('', 'machining', #3700, #3000);
#3702=MACHINING_FEATURE_RELATIONSHIP('', 'machining', #3700, #3703);
#3703=MACHINING_FEATURE_PROCESS('', 'machining', '', '');
#3704=PROPERTY_PROCESS('machining', 'machining', #3703, '');
#3705=PROCESS_PROPERTY_ASSOCIATION('', 'machining', #3704, #3300);
#3706=ACTION_PROPERTY('security plane', 'machining', #3700);
#3707=ACTION_PROPERTY_REPRESENTATION('', 'machining', #3706, #3708);
#3708=REPRESENTATION('', (#1909), #505);

/*****
* Application object: MILLING_TECHNOLOGY (#3800)
* SYNCHRONIZE_SPINDLE_WITH_FEED: #3800, #3801, #3802, #3803, #3804 ['not
synchronized']

```

```

* FEEDRATE_PER_TOOTH: #3800, #3805, #3806, #3807, #3808
* SPINDLE: #3800, #3809, #3810, #3811, #3812
* CUTSPEED: #3800, #3813, #3814, #3815, #3816
* INHIBIT_FEEDRATE_OVERRIDE: #3800, #3817, #3818, #3819, #3820 ['override not
allowed']
* FEEDRATE: #3800, #3821, #3822, #3823, #3824
* FEEDRATE_REFERENCE: #3800, #3825, #3826, #3827, #3828 ['tool center point']
* INHIBIT_SPINDLE_OVERRIDE: #3800, #3829, #3830, #3831, #3832 ['override not
allowed']
*/
#3800=MACHINING_TECHNOLOGY('', 'milling', '', '');
#3801=ACTION_PROPERTY('synchronize spindle with feed', 'milling', #3800);
#3802=ACTION_PROPERTY_REPRESENTATION('', 'milling', #3801, #3803);
#3803=REPRESENTATION('', (#3804), #505);
#3804=DESCRIPTIVE_REPRESENTATION_ITEM('', 'not synchronized');
#3805=ACTION_PROPERTY('feedrate', 'milling', #3800);
#3806=ACTION_PROPERTY_REPRESENTATION('feed per tooth', 'milling', #3805, #3807);
#3807=MACHINING_FEED_SPEED_REPRESENTATION('feed per tooth', (#3808), #505);
#3808=MEASURE_REPRESENTATION_ITEM('feed per tooth', $, #833);
#3809=ACTION_PROPERTY('spindle', 'milling', #3800);
#3810=ACTION_PROPERTY_REPRESENTATION('rotational speed', 'milling', #3809,
#3811);
#3811=MACHINING_SPINDLE_SPEED_REPRESENTATION('spindle speed', (#3812), #505);
#3812=MEASURE_REPRESENTATION_ITEM('rotational speed', NUMERIC_MEASURE(20.),
#837);
#3813=ACTION_PROPERTY('spindle', 'milling', #3800);
#3814=ACTION_PROPERTY_REPRESENTATION('surface speed', 'milling', #3813, #3815);
#3815=MACHINING_SPINDLE_SPEED_REPRESENTATION('cutting speed', (#3816), #505);
#3816=MEASURE_REPRESENTATION_ITEM('surface speed', $, #837);
#3817=ACTION_PROPERTY('inhibit feedrate override', 'milling', #3800);
#3818=ACTION_PROPERTY_REPRESENTATION('', 'milling', #3817, #3819);
#3819=REPRESENTATION('', (#3820), #505);
#3820=DESCRIPTIVE_REPRESENTATION_ITEM('', 'override not allowed');
#3821=ACTION_PROPERTY('feedrate', 'milling', #3800);
#3822=ACTION_PROPERTY_REPRESENTATION('feed speed', 'milling', #3821, #3823);
#3823=MACHINING_FEED_SPEED_REPRESENTATION('feed speed', (#3824), #505);
#3824=MEASURE_REPRESENTATION_ITEM('feed speed', $, #833);
#3825=ACTION_PROPERTY('feedrate reference', 'milling', #3800);
#3826=ACTION_PROPERTY_REPRESENTATION('', 'milling', #3825, #3827);
#3827=REPRESENTATION('', (#3828), #505);
#3828=DESCRIPTIVE_REPRESENTATION_ITEM('', 'tool center point');
#3829=ACTION_PROPERTY('inhibit spindle override', 'milling', #3800);
#3830=ACTION_PROPERTY_REPRESENTATION('', 'milling', #3829, #3831);
#3831=REPRESENTATION('', (#3832), #505);
#3832=DESCRIPTIVE_REPRESENTATION_ITEM('', 'override not allowed');

/*****
* Application object: CONTOUR_BIDIRECTIONAL (#3900)
* OVERLAP: #3900, #3901, #3902, #3903, #3904
*/
#3900=MILLING_TYPE_STRATEGY('', 'contour bidirectional', '', '');
#3901=ACTION_PROPERTY('overlap ratio', 'contour bidirectional', #3900);
#3902=ACTION_PROPERTY_REPRESENTATION('', 'contour bidirectional', #3901, #3903);
#3903=REPRESENTATION('', (#3904), #505);

```

```

#3904= (
MEASURE_REPRESENTATION_ITEM()
MEASURE_WITH_UNIT($,#1217)
RATIO_MEASURE_WITH_UNIT()
REPRESENTATION_ITEM('')
);

/*****
* Application object: BOTTOM_AND_SIDE_ROUGH_MILLING (#4000)
* OVERCUT_LENGTH: #4000, #4001, #4002, #4003, #4004
* RADIAL_CUTTING_DEPTH: #4000, #4005, #4006, #4007, #4008
* ITS_ID: #4000 ['ROUGH_POCKET1']
* ALLOWANCE_SIDE: #4000, #4009, #4010, #4011, #4012
* AXIAL_CUTTING_DEPTH: #4000, #4013, #4014, #4015, #4016
* RETRACT_PLANE: #4000, #4017, #4018, #4019, #4020
* ITS_TOOL: #4000, #600
* ITS_MACHINING_STRATEGY: #4000, #4021, #3900
* ITS_TECHNOLOGY: #4000, #4022, #3800
* ITS_MACHINE_FUNCTIONS: #4000, #4023, #900
* ALLOWANCE_BOTTOM: #4000, #4024, #4025, #4026, #4027
*/
#4000=BOTTOM_AND_SIDE_MILLING_OPERATION('ROUGH_POCKET1','roughing','','');
#4001=ACTION_PROPERTY('overcut length','roughing',#4000);
#4002=ACTION_PROPERTY_REPRESENTATION('','roughing',#4001,#4003);
#4003=REPRESENTATION('',( #4004),#505);
#4004= (
LENGTH_MEASURE_WITH_UNIT()
MEASURE_REPRESENTATION_ITEM()
MEASURE_WITH_UNIT($,#1601)
REPRESENTATION_ITEM('')
);
#4005=ACTION_PROPERTY('radial cutting depth','roughing',#4000);
#4006=ACTION_PROPERTY_REPRESENTATION('','roughing',#4005,#4007);
#4007=REPRESENTATION('',( #4008),#505);
#4008= (
LENGTH_MEASURE_WITH_UNIT()
MEASURE_REPRESENTATION_ITEM()
MEASURE_WITH_UNIT(LENGTH_MEASURE(5.),#1601)
REPRESENTATION_ITEM('')
);
#4009=ACTION_PROPERTY('allowance side','roughing',#4000);
#4010=ACTION_PROPERTY_REPRESENTATION('','roughing',#4009,#4011);
#4011=REPRESENTATION('',( #4012),#505);
#4012= (
LENGTH_MEASURE_WITH_UNIT()
MEASURE_REPRESENTATION_ITEM()
MEASURE_WITH_UNIT(LENGTH_MEASURE(1.),#1601)
REPRESENTATION_ITEM('')
);
#4013=ACTION_PROPERTY('axial cutting depth','roughing',#4000);
#4014=ACTION_PROPERTY_REPRESENTATION('','roughing',#4013,#4015);
#4015=REPRESENTATION('',( #4016),#505);
#4016= (
LENGTH_MEASURE_WITH_UNIT()

```

```

MEASURE_REPRESENTATION_ITEM()
MEASURE_WITH_UNIT(LENGTH_MEASURE(2.5),#1601)
REPRESENTATION_ITEM('')
);
#4017=ACTION_PROPERTY('retract plane','roughing',#4000);
#4018=ACTION_PROPERTY_REPRESENTATION('','roughing',#4017,#4019);
#4019=REPRESENTATION('',( #4020),#505);
#4020=(
LENGTH_MEASURE_WITH_UNIT()
MEASURE_REPRESENTATION_ITEM()
MEASURE_WITH_UNIT(LENGTH_MEASURE(15.),#1601)
REPRESENTATION_ITEM('')
);
#4021=MACHINING_STRATEGY_RELATIONSHIP('machining','roughing',#4000,#3900);
#4022=MACHINING_TECHNOLOGY_RELATIONSHIP('','roughing',#4000,#3800);
#4023=MACHINING_FUNCTIONS_RELATIONSHIP('','roughing',#4000,#900);
#4024=ACTION_PROPERTY('allowance bottom','roughing',#4000);
#4025=ACTION_PROPERTY_REPRESENTATION('','roughing',#4024,#4026);
#4026=REPRESENTATION('',( #4027),#505);
#4027=(
LENGTH_MEASURE_WITH_UNIT()
MEASURE_REPRESENTATION_ITEM()
MEASURE_WITH_UNIT(LENGTH_MEASURE(0.5),#1601)
REPRESENTATION_ITEM('')
);

/*****
* Application object: MILLING_TECHNOLOGY (#4100)
* SYNCHRONIZE_SPINDLE_WITH_FEED: #4100, #4101, #4102, #4103, #4104 ['not
synchronized']
* FEEDRATE_PER_TOOTH: #4100, #4105, #4106, #4107, #4108
* SPINDLE: #4100, #4109, #4110, #4111, #4112
* CUTSPEED: #4100, #4113, #4114, #4115, #4116
* INHIBIT_FEEDRATE_OVERRIDE: #4100, #4117, #4118, #4119, #4120 ['override not
allowed']
* FEEDRATE: #4100, #4121, #4122, #4123, #4124
* FEEDRATE_REFERENCE: #4100, #4125, #4126, #4127, #4128 ['tool center point']
* INHIBIT_SPINDLE_OVERRIDE: #4100, #4129, #4130, #4131, #4132 ['override not
allowed']
*/
#4100=MACHINING_TECHNOLOGY('','milling','','');
#4101=ACTION_PROPERTY('synchronize spindle with feed','milling',#4100);
#4102=ACTION_PROPERTY_REPRESENTATION('','milling',#4101,#4103);
#4103=REPRESENTATION('',( #4104),#505);
#4104=DESCRIPTIVE_REPRESENTATION_ITEM('','not synchronized');
#4105=ACTION_PROPERTY('feedrate','milling',#4100);
#4106=ACTION_PROPERTY_REPRESENTATION('feed per tooth','milling',#4105,#4107);
#4107=MACHINING_FEED_SPEED_REPRESENTATION('feed per tooth',(#4108),#505);
#4108=MEASURE_REPRESENTATION_ITEM('feed per tooth',$,#833);
#4109=ACTION_PROPERTY('spindle','milling',#4100);
#4110=ACTION_PROPERTY_REPRESENTATION('rotational speed','milling',#4109,
#4111);
#4111=MACHINING_SPINDLE_SPEED_REPRESENTATION('spindle speed',(#4112),#505);
#4112=MEASURE_REPRESENTATION_ITEM('rotational speed',NUMERIC_MEASURE(20.),

```



```

#837);
#4113=ACTION_PROPERTY('spindle','milling',#4100);
#4114=ACTION_PROPERTY_REPRESENTATION('surface speed','milling',#4113,#4115);
#4115=MACHINING_SPINDLE_SPEED_REPRESENTATION('cutting speed',(#4116),#505);
#4116=MEASURE_REPRESENTATION_ITEM('surface speed',$,#837);
#4117=ACTION_PROPERTY('inhibit feedrate override','milling',#4100);
#4118=ACTION_PROPERTY_REPRESENTATION('','milling',#4117,#4119);
#4119=REPRESENTATION('',( #4120), #505);
#4120=DESCRIPTIVE_REPRESENTATION_ITEM('','override not allowed');
#4121=ACTION_PROPERTY('feedrate','milling',#4100);
#4122=ACTION_PROPERTY_REPRESENTATION('feed speed','milling',#4121,#4123);
#4123=MACHINING_FEED_SPEED_REPRESENTATION('feed speed',(#4124),#505);
#4124=MEASURE_REPRESENTATION_ITEM('feed speed',$,#833);
#4125=ACTION_PROPERTY('feedrate reference','milling',#4100);
#4126=ACTION_PROPERTY_REPRESENTATION('','milling',#4125,#4127);
#4127=REPRESENTATION('',( #4128), #505);
#4128=DESCRIPTIVE_REPRESENTATION_ITEM('','tool center point');
#4129=ACTION_PROPERTY('inhibit spindle override','milling',#4100);
#4130=ACTION_PROPERTY_REPRESENTATION('','milling',#4129,#4131);
#4131=REPRESENTATION('',( #4132), #505);
#4132=DESCRIPTIVE_REPRESENTATION_ITEM('','override not allowed');

/*****
* Application object: CONTOUR_PARALLEL (#4200)
* CUTMODE: #4200, #4201, #4202, #4203, #4204 ['conventional']
* ROTATION_DIRECTION: #4200, #4205, #4206, #4207, #4208 ['clockwise']
* ALLOW_MULTIPLE_PASSES: #4200, #4209, #4210, #4211, #4212 ['multiple passes
allowed']
* OVERLAP: #4200, #4213, #4214, #4215, #4216
*/
#4200=MILLING_TYPE_STRATEGY('','contour parallel','','');
#4201=ACTION_PROPERTY('cutmode','contour parallel',#4200);
#4202=ACTION_PROPERTY_REPRESENTATION('','contour parallel',#4201,#4203);
#4203=REPRESENTATION('',( #4204), #505);
#4204=DESCRIPTIVE_REPRESENTATION_ITEM('','conventional');
#4205=ACTION_PROPERTY('rotation direction','contour parallel',#4200);
#4206=ACTION_PROPERTY_REPRESENTATION('','contour parallel',#4205,#4207);
#4207=REPRESENTATION('',( #4208), #505);
#4208=DESCRIPTIVE_REPRESENTATION_ITEM('','clockwise');
#4209=ACTION_PROPERTY('multiple passes','contour parallel',#4200);
#4210=ACTION_PROPERTY_REPRESENTATION('','contour parallel',#4209,#4211);
#4211=REPRESENTATION('',( #4212), #505);
#4212=DESCRIPTIVE_REPRESENTATION_ITEM('','multiple passes allowed');
#4213=ACTION_PROPERTY('overlap ratio','contour parallel',#4200);
#4214=ACTION_PROPERTY_REPRESENTATION('','contour parallel',#4213,#4215);
#4215=REPRESENTATION('',( #4216), #505);
#4216= (
MEASURE_REPRESENTATION_ITEM()
MEASURE_WITH_UNIT(RATIO_MEASURE(5.),#1217)
RATIO_MEASURE_WITH_UNIT()
REPRESENTATION_ITEM('')
);

/*****

```

```

* Application object: BOTTOM_AND_SIDE_FINISH_MILLING (#4300)
* AXIAL_CUTTING_DEPTH: #4300, #4301, #4302, #4303, #4304
* ALLOWANCE_SIDE: #4300, #4305, #4306, #4307, #4308
* RETRACT_PLANE: #4300, #4309, #4310, #4311, #4312
* ALLOWANCE_BOTTOM: #4300, #4313, #4314, #4315, #4316
* ITS_MACHINING_STRATEGY: #4300, #4317, #4200
* ITS_ID: #4300 ['FINISHPOCKET1']
* RADIAL_CUTTING_DEPTH: #4300, #4318, #4319, #4320, #4321
* OVERCUT_LENGTH: #4300, #4322, #4323, #4324, #4325
* ITS_MACHINE_FUNCTIONS: #4300, #4326, #900
* ITS_TOOL: #4300, #600
* ITS_TECHNOLOGY: #4300, #4327, #4100
*/
#4300=BOTTOM_AND_SIDE_MILLING_OPERATION('FINISHPOCKET1','finishing','',
');
#4301=ACTION_PROPERTY('axial cutting depth','finishing',#4300);
#4302=ACTION_PROPERTY_REPRESENTATION('','finishing',#4301,#4303);
#4303=REPRESENTATION('',( #4304),#505);
#4304=(
LENGTH_MEASURE_WITH_UNIT()
MEASURE_REPRESENTATION_ITEM()
MEASURE_WITH_UNIT(LENGTH_MEASURE(2.),#1601)
REPRESENTATION_ITEM('')
);
#4305=ACTION_PROPERTY('allowance side','finishing',#4300);
#4306=ACTION_PROPERTY_REPRESENTATION('','finishing',#4305,#4307);
#4307=REPRESENTATION('',( #4308),#505);
#4308=(
LENGTH_MEASURE_WITH_UNIT()
MEASURE_REPRESENTATION_ITEM()
MEASURE_WITH_UNIT($,#1601)
REPRESENTATION_ITEM('')
);
#4309=ACTION_PROPERTY('retract plane','finishing',#4300);
#4310=ACTION_PROPERTY_REPRESENTATION('','finishing',#4309,#4311);
#4311=REPRESENTATION('',( #4312),#505);
#4312=(
LENGTH_MEASURE_WITH_UNIT()
MEASURE_REPRESENTATION_ITEM()
MEASURE_WITH_UNIT(LENGTH_MEASURE(15.),#1601)
REPRESENTATION_ITEM('')
);
#4313=ACTION_PROPERTY('allowance bottom','finishing',#4300);
#4314=ACTION_PROPERTY_REPRESENTATION('','finishing',#4313,#4315);
#4315=REPRESENTATION('',( #4316),#505);
#4316=(
LENGTH_MEASURE_WITH_UNIT()
MEASURE_REPRESENTATION_ITEM()
MEASURE_WITH_UNIT($,#1601)
REPRESENTATION_ITEM('')
);
#4317=MACHINING_STRATEGY_RELATIONSHIP('machining','finishing',#4300,#4200);
#4318=ACTION_PROPERTY('radial cutting depth','finishing',#4300);
#4319=ACTION_PROPERTY_REPRESENTATION('','finishing',#4318,#4320);

```

```

#4320=REPRESENTATION('', (#4321), #505);
#4321=(
LENGTH_MEASURE_WITH_UNIT()
MEASURE_REPRESENTATION_ITEM()
MEASURE_WITH_UNIT(LENGTH_MEASURE(10.), #1601)
REPRESENTATION_ITEM('')
);
#4322=ACTION_PROPERTY('overcut length', 'finishing', #4300);
#4323=ACTION_PROPERTY_REPRESENTATION('', 'finishing', #4322, #4324);
#4324=REPRESENTATION('', (#4325), #505);
#4325=(
LENGTH_MEASURE_WITH_UNIT()
MEASURE_REPRESENTATION_ITEM()
MEASURE_WITH_UNIT($, #1601)
REPRESENTATION_ITEM('')
);
#4326=MACHINING_FUNCTIONS_RELATIONSHIP('', 'finishing', #4300, #900);
#4327=MACHINING_TECHNOLOGY_RELATIONSHIP('', 'finishing', #4300, #4100);

/*****
* Application object: PLANAR_POCKET_BOTTOM_CONDITION (#4400)
*/
#4400=POCKET_BOTTOM('', 'planar', #1509, .F.);

/*****
* Application object: TOLERANCED_LENGTH_MEASURE (#4500)
* VALUE_COMPONENT: #4500 [1]
* UPPER_LIMIT: #4500, #4501 [0.1]
* LOWER_LIMIT: #4500, #4502 [0.1]
*/
#4500=(
LENGTH_MEASURE_WITH_UNIT()
MEASURE_REPRESENTATION_ITEM()
MEASURE_WITH_UNIT(LENGTH_MEASURE(1.), #1601)
QUALIFIED_REPRESENTATION_ITEM((#4502, #4501))
REPRESENTATION_ITEM('fillet radius')
);
#4501=STANDARD_UNCERTAINTY('upper limit', '', 0.1);
#4502=STANDARD_UNCERTAINTY('lower limit', '', 0.1);

/*****
* Application object: TOLERANCED_LENGTH_MEASURE (#4600)
* VALUE_COMPONENT: #4600 [10]
*****
* Application object: QUALIFIED_PLUS_MINUS_VALUE (#4600)
* UPPER_LIMIT: #4600, #4601 [0.1]
* LOWER_LIMIT: #4600, #4602 [0.1]
*/
#4600=(
LENGTH_MEASURE_WITH_UNIT()
MEASURE_REPRESENTATION_ITEM()
MEASURE_WITH_UNIT(LENGTH_MEASURE(10.), #1601)
QUALIFIED_REPRESENTATION_ITEM((#4602, #4601))
REPRESENTATION_ITEM('orthogonal fillet radius')
);

```

```

);
#4601=STANDARD_UNCERTAINTY('upper limit','',0.1);
#4602=STANDARD_UNCERTAINTY('lower limit','',0.1);

/*****
* Application object: GENERAL_CLOSED_PROFILE (#4700)
* CLOSED_PROFILE_SHAPE: #4700, #4701, #4702, #4703, #4704
*/
#4700=CLOSED_PATH_PROFILE('','',#1509,.F.);
#4701=PROPERTY_DEFINITION('','',#4700);
#4702=PROPERTY_DEFINITION_REPRESENTATION(#4701,#4703);
#4703=PATH_SHAPE_REPRESENTATION('',( #4704),#427);
#4704=POLYLINE('CONTOUR OF POCKET1',(#4705,#4706,#4707,#4708,#4705));
#4705=CARTESIAN_POINT('P1',(0.,0.,0.));
#4706=CARTESIAN_POINT('P2',(0.,80.,0.));
#4707=CARTESIAN_POINT('P3',(-50.,80.,0.));
#4708=CARTESIAN_POINT('P4',(-50.,0.,0.));

/*****
* Application object: CLOSED_POCKET (#4800)
* ITS_WORKPIECE: #4800, #401, #400
* BOTTOM_CONDITION: #4800, #4801, #4802, #4803, #4400
* ORTHOGONAL_RADIUS: #4800, #4801, #4804, #4805, #4600
* ITS_ID: #4800 ['POCKET1']
* FEATURE_BOUNDARY: #4800, #4801, #4806, #4807, #4700
* FEATURE_PLACEMENT: #4800, #4801, #4804, #4805, #4808
* DEPTH: #4800, #4801, #4809, #4810, #4811
* COURSE_OF_TRAVEL: #4800, #4801, #4812, #4813, #4900
* BASE_RADIUS: #4800, #4801, #4804, #4805, #4500
*/
#4800=(
CHARACTERIZED_OBJECT('','')
FEATURE_DEFINITION()
INSTANCED_FEATURE()
POCKET()
SHAPE_ASPECT('POCKET1','',#401,.T.)
);
#4801=PRODUCT_DEFINITION_SHAPE('','',#4800);
#4802=SHAPE_ASPECT('','bottom condition occurrence',#4801,.F.);
#4803=FEATURE_COMPONENT_RELATIONSHIP('pocket depth end',
'pocket bottom usage',#4400,#4802);
#4804=SHAPE_DEFINITION_REPRESENTATION(#4801,#4805);
#4805=SHAPE_REPRESENTATION_WITH_PARAMETERS('',( #4808,#4500,#4600),#427);
#4806=SHAPE_ASPECT('','boundary occurrence',#4801,.F.);
#4807=SHAPE_DEFINING_RELATIONSHIP('','profile usage',#4700,#4806);
#4808=AXIS2_PLACEMENT_3D('orientation',#4814,#4907,#4815);
#4809=SHAPE_DEFINITION_REPRESENTATION(#4801,#4810);
#4810=SHAPE_REPRESENTATION('maximum feature limit',(#4811),#427);
#4811=PLANE('DEPTH SURFACE FOR POCKET1',#4816);
#4812=SHAPE_ASPECT('','pocket depth occurrence',#4801,.F.);
#4813=SHAPE_DEFINING_RELATIONSHIP('pocket depth',
'path feature component usage',#4900,#4812);
#4814=CARTESIAN_POINT('POCKET1: LOCATION ',(45.,110.,0.));
#4815=DIRECTION(' REF_DIRECTION',(-1.,0.,0.));

```

```

#4816=AXIS2_PLACEMENT_3D('POCKET1',#4817,#4818,#4819);
#4817=CARTESIAN_POINT('POCKET1: DEPTH ',(0.,0.,-30.));
#4818=DIRECTION(' AXIS ',(0.,0.,1.));
#4819=DIRECTION(' REF_DIRECTION',(1.,0.,0.));

/*****
* Application object: LINEAR_PATH (#4900)
* PLACEMENT: #4900, #4901, #4902, #4903, #4808
* ITS_DIRECTION: #4900, #4904, #4905, #4906, #4907
* DISTANCE: #4900, #4901, #4902, #4903, #4908
*/
#4900=PATH_FEATURE_COMPONENT('','linear',#1509,.F.);
#4901=PROPERTY_DEFINITION('','linear',#4900);
#4902=SHAPE_DEFINITION_REPRESENTATION(#4901,#4903);
#4903=SHAPE_REPRESENTATION_WITH_PARAMETERS('',( #4908,#4808),#427);
#4904=PROPERTY_DEFINITION('','linear',#4900);
#4905=PROPERTY_DEFINITION_REPRESENTATION(#4904,#4906);
#4906=DIRECTION_SHAPE_REPRESENTATION('',( #4907),#505);
#4907=DIRECTION(' AXIS ',(0.,0.,-1.));
#4908=(
LENGTH_MEASURE_WITH_UNIT()
MEASURE_REPRESENTATION_ITEM()
MEASURE_WITH_UNIT(LENGTH_MEASURE(30.),#1601)
REPRESENTATION_ITEM('distance')
);

/*****
* Application object: MACHINING_WORKINGSTEP (#5000)
* ITS_OPERATION: #5000, #5001, #4000
* ITS_FEATURE: #5000, #5002, #5003, #5004, #5005, #4800
* ITS_SECPLANE: #5000, #5006, #5007, #5008, #1909
* ITS_ID: #5000 ['WS ROUGH POCKET1']
*/
#5000=MACHINING_WORKINGSTEP('WS ROUGH POCKET1','machining','','');
#5001=MACHINING_OPERATION_RELATIONSHIP('','machining',#5000,#4000);
#5002=MACHINING_FEATURE_RELATIONSHIP('','machining',#5000,#5003);
#5003=MACHINING_FEATURE_PROCESS('','machining','','');
#5004=PROPERTY_PROCESS('machining','machining',#5003,'');
#5005=PROCESS_PROPERTY_ASSOCIATION('','machining',#5004,#4800);
#5006=ACTION_PROPERTY('security plane','machining',#5000);
#5007=ACTION_PROPERTY_REPRESENTATION('','machining',#5006,#5008);
#5008=REPRESENTATION('',( #1909),#505);

/*****
* Application object: MACHINING_WORKINGSTEP (#5100)
* ITS_OPERATION: #5100, #5101, #4300
* ITS_FEATURE: #5100, #5102, #5103, #5104, #5105, #4800
* ITS_SECPLANE: #5100, #5106, #5107, #5108, #1909
* ITS_ID: #5100 ['WS FINISH POCKET1']
*/
#5100=MACHINING_WORKINGSTEP('WS FINISH POCKET1','machining','','');
#5101=MACHINING_OPERATION_RELATIONSHIP('','machining',#5100,#4300);
#5102=MACHINING_FEATURE_RELATIONSHIP('','machining',#5100,#5103);
#5103=MACHINING_FEATURE_PROCESS('','machining','','');

```

ISO 10303-238:2007(E)

```
#5104=PROPERTY_PROCESS('machining','machining',#5103,'');
#5105=PROCESS_PROPERTY_ASSOCIATION('','machining',#5104,#4800);
#5106=ACTION_PROPERTY('security plane','machining',#5100);
#5107=ACTION_PROPERTY_REPRESENTATION('','machining',#5106,#5108);
#5108=REPRESENTATION('',( #1909),#505);

/*****
 * Application object: REAL_VARIABLE (#5200)
 * ITS_NAME: #5200 ['']
 */
#5200=(
EXPRESSION()
EXPRESSION_REPRESENTATION_ITEM()
GENERIC_EXPRESSION()
GENERIC_VARIABLE()
NUMERIC_EXPRESSION()
NUMERIC_VARIABLE()
REAL_NUMERIC_VARIABLE()
REPRESENTATION_ITEM('')
SIMPLE_GENERIC_EXPRESSION()
SIMPLE_NUMERIC_EXPRESSION()
VARIABLE()
);

/*****
 * Application object: REAL_VARIABLE (#5300)
 * ITS_NAME: #5300 ['']
 */
#5300=(
EXPRESSION()
EXPRESSION_REPRESENTATION_ITEM()
GENERIC_EXPRESSION()
GENERIC_VARIABLE()
NUMERIC_EXPRESSION()
NUMERIC_VARIABLE()
REAL_NUMERIC_VARIABLE()
REPRESENTATION_ITEM('')
SIMPLE_GENERIC_EXPRESSION()
SIMPLE_NUMERIC_EXPRESSION()
VARIABLE()
);

/*****
 * Application object: OFFSET_VECTOR (#5400)
 * TRANSLATE [*]: #5400, #5401, #5200
 * TRANSLATE [*]: #5400, #5402, #5200
 * TRANSLATE [*]: #5400, #5403, #5200
 * ROTATE [*]: #5400, #5404, #5300
 * ROTATE [*]: #5400, #5405, #5300
 * ROTATE [*]: #5400, #5406, #5300
 */
#5400=MACHINING_OFFSET_VECTOR_REPRESENTATION('',( #5401,#5402,#5403,#5404,
#5405,#5406),#427);
#5401=COMPOUND_REPRESENTATION_ITEM('translate',LIST_REPRESENTATION_ITEM((#5200)
```

```

);
#5402=COMPOUND_REPRESENTATION_ITEM('translate',LIST_REPRESENTATION_ITEM((#5200)
));
#5403=COMPOUND_REPRESENTATION_ITEM('translate',LIST_REPRESENTATION_ITEM((#5200)
));
#5404=COMPOUND_REPRESENTATION_ITEM('rotate',LIST_REPRESENTATION_ITEM((#5300)));
#5405=COMPOUND_REPRESENTATION_ITEM('rotate',LIST_REPRESENTATION_ITEM((#5300)));
#5406=COMPOUND_REPRESENTATION_ITEM('rotate',LIST_REPRESENTATION_ITEM((#5300)));

/*****
* Application object: WORKPIECE_SETUP (#5500)
* ITS_OFFSET: #5500, #5501, #5502, #5400
* ITS_WORKPIECE: #5500, #400
* ITS_ORIGIN: #5500, #5503, #5504, #5505, #5506, #5507
*/
#5500=MACHINING_SETUP_WORKPIECE_RELATIONSHIP('', '', '#5600, #400);
#5501=PROPERTY_DEFINITION('computed offset', '#5500);
#5502=PROPERTY_DEFINITION_REPRESENTATION(#5501, #5400);
#5503=PRODUCT_DEFINITION_SHAPE('', '#5500);
#5504=CONTEXT_DEPENDENT_SHAPE_REPRESENTATION(#5505, #5503);
#5505=(
REPRESENTATION_RELATIONSHIP('', '$, $)
REPRESENTATION_RELATIONSHIP_WITH_TRANSFORMATION(#5506)
SHAPE_REPRESENTATION_RELATIONSHIP()
);
#5506=ITEM_DEFINED_TRANSFORMATION('', '$, #5507);
#5507=AXIS2_PLACEMENT_3D('WORKPIECE', #5508, #5509, #5510);
#5508=CARTESIAN_POINT('WORKPIECE1:LOCATION ', (0., 0., 0.));
#5509=DIRECTION(' AXIS ', (0., 0., 1.));
#5510=DIRECTION(' REF_DIRECTION', (1., 0., 0.));

/*****
* Application object: SETUP (#5600)
* ITS_ID: #5600, #5601, #5602 ['SETUP1']
* ITS_WORKPIECE_SETUP [*]: #5600, #5500
* ITS_SECPLANE: #5600, #5603, #5604, #5605, #1909
* ITS_ORIGIN: #5600, #5606, #5607, #5608, #5609
*/
#5600=PRODUCT_DEFINITION('', '#5601, #312);
#5601=PRODUCT_DEFINITION_FORMATION('', '#5602);
#5602=MACHINING_SETUP('SETUP1', '$, (#310));
#5603=PROPERTY_DEFINITION('security plane', '#5600);
#5604=PROPERTY_DEFINITION_REPRESENTATION(#5603, #5605);
#5605=REPRESENTATION('', (#1909), #505);
#5606=PRODUCT_DEFINITION_SHAPE('orientation', '#5600);
#5607=SHAPE_DEFINITION_REPRESENTATION(#5606, #5608);
#5608=REPRESENTATION('', (#5609), #505);
#5609=AXIS2_PLACEMENT_3D('orientation', #5610, #5611, #5612);
#5610=CARTESIAN_POINT('SETUP1: LOCATION ', (150., 90., 40.));
#5611=DIRECTION(' AXIS ', (0., 0., 1.));
#5612=DIRECTION(' REF_DIRECTION', (1., 0., 0.));

/*****
* Application object: WORKPLAN (#5700)

```

```

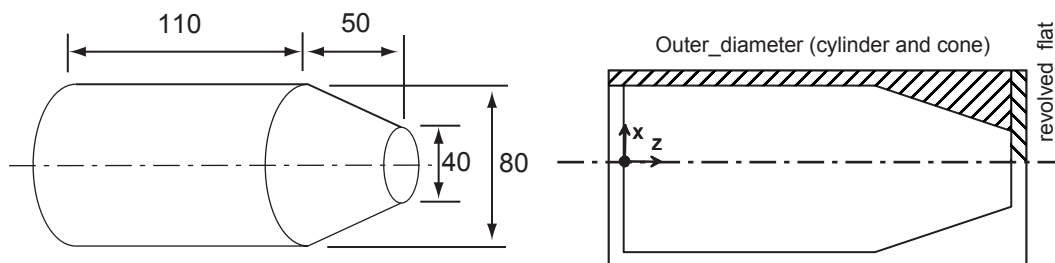
* ITS_SETUP: #5700, #5701, #5702, #5600
* ITS_ELEMENTS [1]: #5700, #5703, #1900
* ITS_ELEMENTS [2]: #5700, #5704, #3600
* ITS_ELEMENTS [3]: #5700, #5705, #3700
* ITS_ELEMENTS [4]: #5700, #5706, #5000
* ITS_ELEMENTS [5]: #5700, #5707, #5100
* ITS_ID: #5700 ['MAIN WORKPLAN']
*/
#5700=MACHINING_WORKPLAN('MAIN WORKPLAN','', '', '');
#5701=PRODUCT_DEFINITION_PROCESS('setup','', #5700, '');
#5702=PROCESS_PRODUCT_ASSOCIATION('', '', #5600, #5701);
#5703=MACHINING_PROCESS_SEQUENCE_RELATIONSHIP('', '', #5700, #1900, 1.);
#5704=MACHINING_PROCESS_SEQUENCE_RELATIONSHIP('', '', #5700, #3600, 2.);
#5705=MACHINING_PROCESS_SEQUENCE_RELATIONSHIP('', '', #5700, #3700, 3.);
#5706=MACHINING_PROCESS_SEQUENCE_RELATIONSHIP('', '', #5700, #5000, 4.);
#5707=MACHINING_PROCESS_SEQUENCE_RELATIONSHIP('', '', #5700, #5100, 5.);

/*****
* Application object: PROJECT (#5800)
* MAIN_WORKPLAN: #5800, #5801, #5802, #5700
* ITS_ID: #5800, #5803, #5804 ['EXECUTE EXAMPLE1']
* ITS_WORKPIECES [*]: #5800, #5805, #400
*/
#5800=PRODUCT_DEFINITION('', '', #5803, #312);
#5801=PROCESS_PRODUCT_ASSOCIATION('', '', #5800, #5802);
#5802=PRODUCT_DEFINITION_PROCESS('machining','', #5700, '');
#5803=PRODUCT_DEFINITION_FORMATION('', '', #5804);
#5804=MACHINING_PROJECT('EXECUTE EXAMPLE1','', $, (#310));
#5805=MACHINING_PROJECT_WORKPIECE_RELATIONSHIP('', 'workpiece','', #5800, #400);
ENDSEC;
END-ISO-10303-21;

```

### J.7 Data set for ISO 14649-12 example #1 (CC3)

The following example is defined by Annex D of ISO 14649-12:2005 and describes a machining project for a turned part containing the features shown in Figure J.3. The data set follows the original ordering of application object instances in the ISO 14649-12 example. This example is a conformance class three file and contains no toolpaths. The processing system must generate toolpaths from the supplied features in order to machine the part.



**Figure J.3 — Workpiece from ISO 14649-12 example #1**



```

ISO-10303-21;
HEADER;
FILE_DESCRIPTION(
/* description */ ('AP238 AIM version of ISO14649-12 example #1'),
/* implementation_level */ '2;1');

FILE_NAME(
/* name */ 'p12_example1_aim',
/* time_stamp */ '2006-06-15T16:49:14-04:00',
/* author */ ('Dave Loffredo (loffredo@steptools.com)'),
/* organization */ (''),
/* preprocessor_version */ 'ST-DEVELOPER v11',
/* originating_system */ '',
/* authorisation */ '');

FILE_SCHEMA (('INTEGRATED_CNC_SCHEMA'));
ENDSEC;

DATA;

/*****
* Application object: WORKPIECE (#100)
* ITS_MATERIAL [1]: #100, #102, #103, #200
* ITS_ID: #100 ['SIMPLE WORKPIECE']
* SHAPE_DEFINITION: #100, #101
* GLOBAL_TOLERANCE: #100, #104, #105, #106, #107
*/
#100=PRODUCT_DEFINITION('SIMPLE WORKPIECE','',#108,#112);
#101=PRODUCT_DEFINITION_SHAPE('','',#100);
#102=MAKE_FROM_USAGE_OPTION('','',',',#100,#103,1,',',');
#103=PRODUCT_DEFINITION('','',',',');
#104=PROPERTY_DEFINITION('global tolerance','',#100);
#105=PROPERTY_DEFINITION_REPRESENTATION(#104,#106);
#106=SHAPE_REPRESENTATION('',( #107),#113);
#107=(
LENGTH_MEASURE_WITH_UNIT()
MEASURE_REPRESENTATION_ITEM()
MEASURE_WITH_UNIT(LENGTH_MEASURE(0.01),#119)
REPRESENTATION_ITEM('')
);
#108=PRODUCT_DEFINITION_FORMATION('1.0','Workpiece',#109);
#109=PRODUCT('WP','AP-238 CC1',' ',(#110));
#110=PRODUCT_CONTEXT('CNC Machining',#111,'manufacturing');
#111=APPLICATION_CONTEXT(
'Application protocol for the exchange of CNC data');
#112=PRODUCT_DEFINITION_CONTEXT('CNC Machining',#111,'manufacturing');
#113=(
GEOMETRIC_REPRESENTATION_CONTEXT(3)
GLOBAL_UNIT_ASSIGNED_CONTEXT((#119,#114,#118))
REPRESENTATION_CONTEXT('MILLIMETRE DEGREE STERADIAN','')
);
#114=(
CONVERSION_BASED_UNIT('degree',#116)
NAMED_UNIT(#115)

```

ISO 10303-238:2007(E)

```

PLANE_ANGLE_UNIT()
);
#115=DIMENSIONAL_EXPONENTS(0.,0.,0.,0.,0.,0.);
#116=PLANE_ANGLE_MEASURE_WITH_UNIT(PLANE_ANGLE_MEASURE(0.01745329252),#117);
#117=(
NAMED_UNIT(*)
PLANE_ANGLE_UNIT()
SI_UNIT($,.RADIAN.)
);
#118=(
NAMED_UNIT(*)
SI_UNIT($,.STERADIAN.)
SOLID_ANGLE_UNIT()
);
#119=(
LENGTH_UNIT()
NAMED_UNIT(*)
SI_UNIT(.MILLI.,.METRE.)
);
#120=(
NAMED_UNIT(*)
SI_UNIT($,.SECOND.)
TIME_UNIT()
);
#121=APPLICATION_PROTOCOL_DEFINITION('international standard',
'integrated_cnc_schema',2006,#111);

/*****
* Application object: MATERIAL (#200)
* MATERIAL_PROPERTY [*]: #200, #201, #202, #203, #300
* MATERIAL_IDENTIFIER: #200 ['E 295']
* STANDARD_IDENTIFIER: #200, #204, #205 ['DIN EN 10027-1']
*/
#200=MATERIAL_DESIGNATION('E 295',(#103));
#201=MATERIAL_DESIGNATION_CHARACTERIZATION('','',#200,#202);
#202=MATERIAL_PROPERTY_REPRESENTATION($,#203,$);
#203=REPRESENTATION('',( #300), $);
#204=APPLIED_DOCUMENT_REFERENCE(#205,'',( #200));
#205=DOCUMENT('DIN EN 10027-1','', '$);

/*****
* Application object: NUMERIC_PARAMETER (#300)
* ITS_PARAMETER_VALUE: #300 [2e+011]
* ITS_PARAMETER_UNIT: #300, #301
* PARAMETER_NAME: #300 ['ELASTIC MODULUS']
*/
#300=MEASURE_REPRESENTATION_ITEM('ELASTIC
MODULUS',NUMERIC_MEASURE(200000000000.),
#301);
#301=SI_UNIT(*,$,.PASCAL.);

/*****
* Application object: REVOLVED_FLAT (#400)
* FLAT_EDGE_SHAPE: #400, #401, #402, #403, #3800

```

```

* RADIUS: #400, #404, #405, #406, #407
* MATERIAL_SIDE: #400, #408, #409, #410, #411
* ITS_ID: #400 ['END FACE']
* ITS_WORKPIECE: #400, #101, #100
* FEATURE_PLACEMENT: #400, #404, #405, #406, #412
*/
#400=(
CHARACTERIZED_OBJECT('', 'flat')
FEATURE_DEFINITION()
INSTANCED_FEATURE()
REVOLVED_PROFILE()
SHAPE_ASPECT('END FACE', 'flat', #101, .F.)
);
#401=PRODUCT_DEFINITION_SHAPE('', 'flat edge shape', #400);
#402=SHAPE_ASPECT('', 'flat edge shape occurrence', #401, .F.);
#403=SHAPE_DEFINING_RELATIONSHIP('', 'profile usage', #3800, #402);
#404=PRODUCT_DEFINITION_SHAPE('', 'flat', #400);
#405=SHAPE_DEFINITION_REPRESENTATION(#404, #406);
#406=SHAPE_REPRESENTATION_WITH_PARAMETERS('', (#412, #407), #113);
#407=(
LENGTH_MEASURE_WITH_UNIT()
MEASURE_REPRESENTATION_ITEM()
MEASURE_WITH_UNIT(LENGTH_MEASURE(0.), #119)
REPRESENTATION_ITEM('radius')
);
#408=PRODUCT_DEFINITION_SHAPE('', 'flat', #400);
#409=PROPERTY_DEFINITION_REPRESENTATION(#408, #410);
#410=DIRECTION_SHAPE_REPRESENTATION('removal direction', (#411), #113);
#411=DIRECTION('END FACE: FRONT', (0., 0., -1.));
#412=AXIS2_PLACEMENT_3D('orientation', #414, $, $);
#413=REPRESENTATION_CONTEXT('', 'units not necessary');
#414=CARTESIAN_POINT('END FACE: LOCATION', (0., 0., 160.));

/*****
* Application object: OUTER_DIAMETER (#500)
* ITS_ID: #500 ['CONE']
* REDUCED_SIZE: #500, #501, #502, #503, #4100
* FEATURE_LENGTH: #500, #504, #505, #506, #4000
* FEATURE_PLACEMENT: #500, #504, #505, #506, #507
* ITS_WORKPIECE: #500, #101, #100
* DIAMETER_AT_PLACEMENT: #500, #504, #505, #506, #3700
*/
#500=(
CHARACTERIZED_OBJECT('', 'outer diameter')
FEATURE_DEFINITION()
INSTANCED_FEATURE()
OUTER_ROUND()
SHAPE_ASPECT('CONE', 'outer diameter', #101, .F.)
);
#501=PRODUCT_DEFINITION_SHAPE('', 'outer diameter', #500);
#502=SHAPE_ASPECT('', 'reduced size occurrence', #501, .F.);
#503=FEATURE_COMPONENT_RELATIONSHIP('reduced size', 'taper usage', #4100, #502);
#504=PRODUCT_DEFINITION_SHAPE('', 'outer diameter', #500);
#505=SHAPE_DEFINITION_REPRESENTATION(#504, #506);

```

```

#506=SHAPE_REPRESENTATION_WITH_PARAMETERS('',( #507,#3700,#4000),#113);
#507=AXIS2_PLACEMENT_3D('orientation',#508,$,$);
#508=CARTESIAN_POINT('CONE: LOCATION',(0.,0.,160.));

/*****
* Application object: OUTER_DIAMETER (#600)
* ITS_ID: #600 ['CYLINDER']
* FEATURE_LENGTH: #600, #601, #602, #603, #3600
* FEATURE_PLACEMENT: #600, #601, #602, #603, #604
* ITS_WORKPIECE: #600, #101, #100
* DIAMETER_AT_PLACEMENT: #600, #601, #602, #603, #3500
*/
#600=(
CHARACTERIZED_OBJECT('','outer diameter')
FEATURE_DEFINITION()
INSTANCED_FEATURE()
OUTER_ROUND()
SHAPE_ASPECT('CYLINDER','outer diameter',#101,.F.)
);
#601=PRODUCT_DEFINITION_SHAPE('','outer diameter',#600);
#602=SHAPE_DEFINITION_REPRESENTATION(#601,#603);
#603=SHAPE_REPRESENTATION_WITH_PARAMETERS('',( #604,#3500,#3600),#113);
#604=AXIS2_PLACEMENT_3D('orientation',#605,$,$);
#605=CARTESIAN_POINT('CYLINDER: LOCATION',(0.,0.,110.));

/*****
* Application object: FACING_ROUGH (#700)
* ITS_TECHNOLOGY: #700, #701, #2000
* RETRACT: #700, #702, #3100
* ALLOWANCE: #700, #703, #704, #705, #706
* ITS_ID: #700 ['ROUGH END FACE']
* APPROACH: #700, #707, #3000
* ITS_TOOL: #700, #4300
* ITS_MACHINING_STRATEGY: #700, #708, #2800
* ITS_MACHINE_FUNCTIONS: #700, #709, #1900
*/
#700=FACING_TURNING_OPERATION('ROUGH END FACE','roughing','','');
#701=MACHINING_TECHNOLOGY_RELATIONSHIP('','roughing',#700,#2000);
#702=MACHINING_STRATEGY_RELATIONSHIP('retract','roughing',#700,#3100);
#703=ACTION_PROPERTY('allowance','roughing',#700);
#704=ACTION_PROPERTY_REPRESENTATION('','roughing',#703,#705);
#705=REPRESENTATION('',( #706),#413);
#706=(
LENGTH_MEASURE_WITH_UNIT()
MEASURE_REPRESENTATION_ITEM()
MEASURE_WITH_UNIT(LENGTH_MEASURE(0.5),#119)
REPRESENTATION_ITEM('')
);
#707=MACHINING_STRATEGY_RELATIONSHIP('approach','roughing',#700,#3000);
#708=MACHINING_STRATEGY_RELATIONSHIP('machining','roughing',#700,#2800);
#709=MACHINING_FUNCTIONS_RELATIONSHIP('','roughing',#700,#1900);

/*****
* Application object: FACING_FINISH (#800)

```

```

* APPROACH: #800, #801, #3000
* ALLOWANCE: #800, #802, #803, #804, #805
* ITS_TOOL: #800, #4600
* ITS_TECHNOLOGY: #800, #806, #2100
* ITS_MACHINE_FUNCTIONS: #800, #807, #1900
* ITS_MACHINING_STRATEGY: #800, #808, #2900
* ITS_ID: #800 ['FINISH END FACE']
* RETRACT: #800, #809, #3100
*/
#800=FACING_TURNING_OPERATION('FINISH END FACE','finishing','','');
#801=MACHINING_STRATEGY_RELATIONSHIP('approach','finishing',#800,#3000);
#802=ACTION_PROPERTY('allowance','finishing',#800);
#803=ACTION_PROPERTY_REPRESENTATION('','finishing',#802,#804);
#804=REPRESENTATION('',( #805),#413);
#805=(
LENGTH_MEASURE_WITH_UNIT()
MEASURE_REPRESENTATION_ITEM()
MEASURE_WITH_UNIT(LENGTH_MEASURE(0.),#119)
REPRESENTATION_ITEM('')
);
#806=MACHINING_TECHNOLOGY_RELATIONSHIP('','finishing',#800,#2100);
#807=MACHINING_FUNCTIONS_RELATIONSHIP('','finishing',#800,#1900);
#808=MACHINING_STRATEGY_RELATIONSHIP('machining','finishing',#800,#2900);
#809=MACHINING_STRATEGY_RELATIONSHIP('retract','finishing',#800,#3100);

/*****
* Application object: CONTOURING_ROUGH (#900)
* APPROACH: #900, #901, #3400
* RETRACT: #900, #902, #3400
* ITS_TOOL: #900, #4300
* ITS_ID: #900 ['ROUGH CONTOUR']
* ALLOWANCE: #900, #903, #904, #905, #906
* ITS_MACHINING_STRATEGY: #900, #907, #3200
* ITS_MACHINE_FUNCTIONS: #900, #908, #1900
* ITS_TECHNOLOGY: #900, #909, #2200
*/
#900=CONTOURING_TURNING_OPERATION('ROUGH CONTOUR','roughing','','');
#901=MACHINING_STRATEGY_RELATIONSHIP('approach','roughing',#900,#3400);
#902=MACHINING_STRATEGY_RELATIONSHIP('retract','roughing',#900,#3400);
#903=ACTION_PROPERTY('allowance','roughing',#900);
#904=ACTION_PROPERTY_REPRESENTATION('','roughing',#903,#905);
#905=REPRESENTATION('',( #906),#413);
#906=(
LENGTH_MEASURE_WITH_UNIT()
MEASURE_REPRESENTATION_ITEM()
MEASURE_WITH_UNIT(LENGTH_MEASURE(0.5),#119)
REPRESENTATION_ITEM('')
);
#907=MACHINING_STRATEGY_RELATIONSHIP('machining','roughing',#900,#3200);
#908=MACHINING_FUNCTIONS_RELATIONSHIP('','roughing',#900,#1900);
#909=MACHINING_TECHNOLOGY_RELATIONSHIP('','roughing',#900,#2200);

/*****
* Application object: CONTOURING_FINISH (#1000)

```

ISO 10303-238:2007(E)

```

* ITS_MACHINING_STRATEGY: #1000, #1001, #3300
* ITS_ID: #1000 ['FINISH CONTOUR']
* APPROACH: #1000, #1002, #3400
* ITS_MACHINE_FUNCTIONS: #1000, #1003, #1900
* ITS_TOOL: #1000, #4600
* ITS_TECHNOLOGY: #1000, #1004, #2300
* ALLOWANCE: #1000, #1005, #1006, #1007, #1008
* RETRACT: #1000, #1009, #3400
*/
#1000=CONTOURING_TURNING_OPERATION('FINISH CONTOUR','finishing','','');
#1001=MACHINING_STRATEGY_RELATIONSHIP('machining','finishing',#1000,#3300);
#1002=MACHINING_STRATEGY_RELATIONSHIP('approach','finishing',#1000,#3400);
#1003=MACHINING_FUNCTIONS_RELATIONSHIP('','finishing',#1000,#1900);
#1004=MACHINING_TECHNOLOGY_RELATIONSHIP('','finishing',#1000,#2300);
#1005=ACTION_PROPERTY('allowance','finishing',#1000);
#1006=ACTION_PROPERTY_REPRESENTATION('','finishing',#1005,#1007);
#1007=REPRESENTATION('',( #1008),#413);
#1008=(
LENGTH_MEASURE_WITH_UNIT()
MEASURE_REPRESENTATION_ITEM()
MEASURE_WITH_UNIT(LENGTH_MEASURE(0.),#119)
REPRESENTATION_ITEM('')
);
#1009=MACHINING_STRATEGY_RELATIONSHIP('retract','finishing',#1000,#3400);

/*****
* Application object: PROJECT (#1100)
* MAIN_WORKPLAN: #1100, #1101, #1102, #1200
* ITS_ID: #1100, #1103, #1104 ['TURNING EXAMPLE 1']
* ITS_WORKPIECES [*]: #1100, #1105, #100
*/
#1100=PRODUCT_DEFINITION('','',#1103,#112);
#1101=PROCESS_PRODUCT_ASSOCIATION('','',#1100,#1102);
#1102=PRODUCT_DEFINITION_PROCESS('machining','',#1200,'');
#1103=PRODUCT_DEFINITION_FORMATION('','',#1104);
#1104=MACHINING_PROJECT('TURNING EXAMPLE 1','',$( #110));
#1105=MACHINING_PROJECT_WORKPIECE_RELATIONSHIP('','workpiece','',#1100,#100);

/*****
* Application object: WORKPLAN (#1200)
* ITS_ID: #1200 ['MAIN WORKPLAN']
* ITS_SETUP: #1200, #1201, #1202, #1700
* ITS_ELEMENTS [1]: #1200, #1203, #1300
* ITS_ELEMENTS [2]: #1200, #1204, #1400
* ITS_ELEMENTS [3]: #1200, #1205, #1500
* ITS_ELEMENTS [4]: #1200, #1206, #1600
*/
#1200=MACHINING_WORKPLAN('MAIN WORKPLAN','',',');
#1201=PRODUCT_DEFINITION_PROCESS('setup','',#1200,'');
#1202=PROCESS_PRODUCT_ASSOCIATION('','',#1700,#1201);
#1203=MACHINING_PROCESS_SEQUENCE_RELATIONSHIP('','',#1200,#1300,1.);
#1204=MACHINING_PROCESS_SEQUENCE_RELATIONSHIP('','',#1200,#1400,2.);
#1205=MACHINING_PROCESS_SEQUENCE_RELATIONSHIP('','',#1200,#1500,3.);
#1206=MACHINING_PROCESS_SEQUENCE_RELATIONSHIP('','',#1200,#1600,4.);

```

```

/*****
* Application object: MACHINING_WORKINGSTEP (#1300)
* ITS_FEATURE: #1300, #1301, #1302, #1303, #1304, #400
* ITS_ID: #1300 ['WS ROUGH END FACE']
* ITS_SECPANE: #1300, #1305, #1306, #1307, #1308
* ITS_OPERATION: #1300, #1309, #700
*/
#1300=MACHINING_WORKINGSTEP('WS ROUGH END FACE','machining','','');
#1301=MACHINING_FEATURE_RELATIONSHIP('','machining',#1300,#1302);
#1302=MACHINING_FEATURE_PROCESS('','machining','','');
#1303=PROPERTY_PROCESS('machining','machining',#1302,'');
#1304=PROCESS_PROPERTY_ASSOCIATION('','machining',#1303,#400);
#1305=ACTION_PROPERTY('security plane','machining',#1300);
#1306=ACTION_PROPERTY_REPRESENTATION('','machining',#1305,#1307);
#1307=REPRESENTATION('',( #1308 ),#413);
#1308=PLANE('SECURITY PLANE',#1310);
#1309=MACHINING_OPERATION_RELATIONSHIP('','machining',#1300,#700);
#1310=AXIS2_PLACEMENT_3D('SECURITY PLANE',#1311,$,$);
#1311=CARTESIAN_POINT('SECPLANE: LOCATION',(90.,0.,200.));

/*****
* Application object: MACHINING_WORKINGSTEP (#1400)
* ITS_FEATURE: #1400, #1401, #1402, #1403, #1404, #400
* ITS_ID: #1400 ['WS FINISH END FACE']
* ITS_SECPANE: #1400, #1405, #1406, #1407, #1308
* ITS_OPERATION: #1400, #1408, #800
*/
#1400=MACHINING_WORKINGSTEP('WS FINISH END FACE','machining','','');
#1401=MACHINING_FEATURE_RELATIONSHIP('','machining',#1400,#1402);
#1402=MACHINING_FEATURE_PROCESS('','machining','','');
#1403=PROPERTY_PROCESS('machining','machining',#1402,'');
#1404=PROCESS_PROPERTY_ASSOCIATION('','machining',#1403,#400);
#1405=ACTION_PROPERTY('security plane','machining',#1400);
#1406=ACTION_PROPERTY_REPRESENTATION('','machining',#1405,#1407);
#1407=REPRESENTATION('',( #1308 ),#413);
#1408=MACHINING_OPERATION_RELATIONSHIP('','machining',#1400,#800);

/*****
* Application object: TURNING_WORKINGSTEP (#1500)
* ITS_ID: #1500 ['WS ROUGH CONTOUR']
* ITS_SECPANE: #1500, #1501, #1502, #1503, #1308
* ITS_OPERATION: #1500, #1504, #900
* ITS_FEATURES [*]: #1500, #1505, #1506, #1507, #1508, #500
* ITS_FEATURES [*]: #1500, #1509, #1510, #1511, #1512, #600
*/
#1500=MACHINING_WORKINGSTEP('WS ROUGH CONTOUR','turning','','');
#1501=ACTION_PROPERTY('security plane','turning',#1500);
#1502=ACTION_PROPERTY_REPRESENTATION('','turning',#1501,#1503);
#1503=REPRESENTATION('',( #1308 ),#413);
#1504=MACHINING_OPERATION_RELATIONSHIP('','turning',#1500,#900);
#1505=MACHINING_FEATURE_SEQUENCE_RELATIONSHIP('','turning',#1500,#1506,0.);
#1506=MACHINING_FEATURE_PROCESS('','turning','','');
#1507=PROPERTY_PROCESS('machining','turning',#1506,'');

```

```
#1508=PROCESS_PROPERTY_ASSOCIATION('', 'turning', #1507, #500);
#1509=MACHINING_FEATURE_SEQUENCE_RELATIONSHIP('', 'turning', #1500, #1510, 0.);
#1510=MACHINING_FEATURE_PROCESS('', 'turning', '', '');
#1511=PROPERTY_PROCESS('machining', 'turning', #1510, '');
#1512=PROCESS_PROPERTY_ASSOCIATION('', 'turning', #1511, #600);
```

```
/******
```

```
* Application object: TURNING_WORKINGSTEP (#1600)
* ITS_ID: #1600 ['WS FINISH CONTOUR']
* ITS_SECPANE: #1600, #1601, #1602, #1603, #1308
* ITS_OPERATION: #1600, #1604, #1000
* ITS_FEATURES [*]: #1600, #1605, #1606, #1607, #1608, #500
* ITS_FEATURES [*]: #1600, #1609, #1610, #1611, #1612, #600
*/
```

```
#1600=MACHINING_WORKINGSTEP('WS FINISH CONTOUR', 'turning', '', '');
#1601=ACTION_PROPERTY('security plane', 'turning', #1600);
#1602=ACTION_PROPERTY_REPRESENTATION('', 'turning', #1601, #1603);
#1603=REPRESENTATION('', (#1308), #413);
#1604=MACHINING_OPERATION_RELATIONSHIP('', 'turning', #1600, #1000);
#1605=MACHINING_FEATURE_SEQUENCE_RELATIONSHIP('', 'turning', #1600, #1606, 0.);
#1606=MACHINING_FEATURE_PROCESS('', 'turning', '', '');
#1607=PROPERTY_PROCESS('machining', 'turning', #1606, '');
#1608=PROCESS_PROPERTY_ASSOCIATION('', 'turning', #1607, #500);
#1609=MACHINING_FEATURE_SEQUENCE_RELATIONSHIP('', 'turning', #1600, #1610, 0.);
#1610=MACHINING_FEATURE_PROCESS('', 'turning', '', '');
#1611=PROPERTY_PROCESS('machining', 'turning', #1610, '');
#1612=PROCESS_PROPERTY_ASSOCIATION('', 'turning', #1611, #600);
```

```
/******
```

```
* Application object: SETUP (#1700)
* ITS_SECPANE: #1700, #1701, #1702, #1703, #1308
* ITS_WORKPIECE_SETUP [*]: #1700, #1800
* ITS_ID: #1700, #1704, #1705 ['SETUP FOR TURNING EXAMPLE 1']
*/
```

```
#1700=PRODUCT_DEFINITION('', '', #1704, #112);
#1701=PROPERTY_DEFINITION('security plane', '', #1700);
#1702=PROPERTY_DEFINITION_REPRESENTATION(#1701, #1703);
#1703=REPRESENTATION('', (#1308), #413);
#1704=PRODUCT_DEFINITION_FORMATION('', '', #1705);
#1705=MACHINING_SETUP('SETUP FOR TURNING EXAMPLE 1', '', $, (#110));
```

```
/******
```

```
* Application object: WORKPIECE_SETUP (#1800)
* ITS_ORIGIN: #1800, #1801, #1802, #1803, #1804, #1805
* ITS_WORKPIECE: #1800, #100
*/
```

```
#1800=MACHINING_SETUP_WORKPIECE_RELATIONSHIP('', '', '#1700, #100);
#1801=PRODUCT_DEFINITION_SHAPE('', '#1800);
#1802=CONTEXT_DEPENDENT_SHAPE_REPRESENTATION(#1803, #1801);
#1803=(
REPRESENTATION_RELATIONSHIP('', '$, $)
REPRESENTATION_RELATIONSHIP_WITH_TRANSFORMATION(#1804)
SHAPE_REPRESENTATION_RELATIONSHIP()
);
```



```

#1804=ITEM_DEFINED_TRANSFORMATION('', '$', #1805);
#1805=AXIS2_PLACEMENT_3D('WORKPIECE', #1806, #1807, #1808);
#1806=CARTESIAN_POINT('WORKPIECE: LOCATION', (0., 0., 0.));
#1807=DIRECTION('WORKPIECE: AXIS', (0., 0., 1.));
#1808=DIRECTION('WORKPIECE: REF_DIRECTION', (1., 0., 0.));

/*****
* Application object: TURNING_MACHINE_FUNCTIONS (#1900)
* COOLANT: #1900, #1901, #1902, #1903, #1904 ['coolant on']
* CHIP_REMOVAL: #1900, #1905, #1906, #1907, #1908 ['chip removal off']
*/
#1900=MACHINING_FUNCTIONS('', 'turning', '', '');
#1901=ACTION_PROPERTY('coolant', 'turning', #1900);
#1902=ACTION_PROPERTY_REPRESENTATION('', 'turning', #1901, #1903);
#1903=REPRESENTATION('', (#1904), #413);
#1904=DESCRIPTIVE_REPRESENTATION_ITEM('', 'coolant on');
#1905=ACTION_PROPERTY('chip removal', 'turning', #1900);
#1906=ACTION_PROPERTY_REPRESENTATION('', 'turning', #1905, #1907);
#1907=REPRESENTATION('', (#1908), #413);
#1908=DESCRIPTIVE_REPRESENTATION_ITEM('', 'chip removal off');

/*****
* Application object: TURNING_TECHNOLOGY (#2000)
* INHIBIT_SPINDLE_OVERRIDE: #2000, #2001, #2002, #2003, #2004 ['override not
allowed']
* SYNC_SPINDLE_AND_Z_FEED: #2000, #2005, #2006, #2007, #2008 ['not
synchronized']
* FEEDRATE_PER_REVOLUTION: #2000, #2009, #2010, #2011, #2012
* FEEDRATE_REFERENCE: #2000, #2013, #2014, #2015, #2016 ['tool center point']
* INHIBIT_FEEDRATE_OVERRIDE: #2000, #2017, #2018, #2019, #2020 ['override not
allowed']
* SPINDLE_SPEED: #2000, #2021, #2022, #2400
*/
#2000=MACHINING_TECHNOLOGY('', 'turning', '', '');
#2001=ACTION_PROPERTY('inhibit spindle override', 'turning', #2000);
#2002=ACTION_PROPERTY_REPRESENTATION('', 'turning', #2001, #2003);
#2003=REPRESENTATION('', (#2004), #413);
#2004=DESCRIPTIVE_REPRESENTATION_ITEM('', 'override not allowed');
#2005=ACTION_PROPERTY('synchronize spindle with z feed', 'turning', #2000);
#2006=ACTION_PROPERTY_REPRESENTATION('', 'turning', #2005, #2007);
#2007=REPRESENTATION('', (#2008), #413);
#2008=DESCRIPTIVE_REPRESENTATION_ITEM('', 'not synchronized');
#2009=ACTION_PROPERTY('feedrate', 'turning', #2000);
#2010=ACTION_PROPERTY_REPRESENTATION('feed per revolution', 'turning', #2009,
#2011);
#2011=MACHINING_FEED_SPEED_REPRESENTATION('feed per revolution', (#2012),
#413);
#2012=MEASURE_REPRESENTATION_ITEM('feed per revolution', NUMERIC_MEASURE(0.3),
#2023);
#2013=ACTION_PROPERTY('feedrate reference', 'turning', #2000);
#2014=ACTION_PROPERTY_REPRESENTATION('', 'turning', #2013, #2015);
#2015=REPRESENTATION('', (#2016), #413);
#2016=DESCRIPTIVE_REPRESENTATION_ITEM('', 'tool center point');
#2017=ACTION_PROPERTY('inhibit feedrate override', 'turning', #2000);

```

```

#2018=ACTION_PROPERTY_REPRESENTATION('','turning',#2017,#2019);
#2019=REPRESENTATION('',( #2020),#413);
#2020=DESCRIPTIVE_REPRESENTATION_ITEM('','override not allowed');
#2021=ACTION_PROPERTY('spindle','turning',#2000);
#2022=ACTION_PROPERTY_REPRESENTATION('spindle speed','turning',#2021,#2400);
#2023=DERIVED_UNIT((#2024,#2025));
#2024=DERIVED_UNIT_ELEMENT(#119,1.);
#2025=DERIVED_UNIT_ELEMENT(#120,-1.);
#2026=NAME_ATTRIBUTE('millimetre/second',#2023);

/*****
* Application object: TURNING_TECHNOLOGY (#2100)
* INHIBIT_SPINDLE_OVERRIDE: #2100, #2101, #2102, #2103, #2104 ['override not
allowed']
* SYNC_SPINDLE_AND_Z_FEED: #2100, #2105, #2106, #2107, #2108 ['not
synchronized']
* FEEDRATE_PER_REVOLUTION: #2100, #2109, #2110, #2111, #2112
* FEEDRATE_REFERENCE: #2100, #2113, #2114, #2115, #2116 ['tool center point']
* INHIBIT_FEEDRATE_OVERRIDE: #2100, #2117, #2118, #2119, #2120 ['override not
allowed']
* SPINDLE_SPEED: #2100, #2121, #2122, #2500
*/
#2100=MACHINING_TECHNOLOGY('','turning','','');
#2101=ACTION_PROPERTY('inhibit spindle override','turning',#2100);
#2102=ACTION_PROPERTY_REPRESENTATION('','turning',#2101,#2103);
#2103=REPRESENTATION('',( #2104),#413);
#2104=DESCRIPTIVE_REPRESENTATION_ITEM('','override not allowed');
#2105=ACTION_PROPERTY('synchronize spindle with z feed','turning',#2100);
#2106=ACTION_PROPERTY_REPRESENTATION('','turning',#2105,#2107);
#2107=REPRESENTATION('',( #2108),#413);
#2108=DESCRIPTIVE_REPRESENTATION_ITEM('','not synchronized');
#2109=ACTION_PROPERTY('feedrate','turning',#2100);
#2110=ACTION_PROPERTY_REPRESENTATION('feed per revolution','turning',#2109,
#2111);
#2111=MACHINING_FEED_SPEED_REPRESENTATION('feed per revolution',( #2112),
#413);
#2112=MEASURE_REPRESENTATION_ITEM('feed per revolution',NUMERIC_MEASURE(0.2),
#2023);
#2113=ACTION_PROPERTY('feedrate reference','turning',#2100);
#2114=ACTION_PROPERTY_REPRESENTATION('','turning',#2113,#2115);
#2115=REPRESENTATION('',( #2116),#413);
#2116=DESCRIPTIVE_REPRESENTATION_ITEM('','tool center point');
#2117=ACTION_PROPERTY('inhibit feedrate override','turning',#2100);
#2118=ACTION_PROPERTY_REPRESENTATION('','turning',#2117,#2119);
#2119=REPRESENTATION('',( #2120),#413);
#2120=DESCRIPTIVE_REPRESENTATION_ITEM('','override not allowed');
#2121=ACTION_PROPERTY('spindle','turning',#2100);
#2122=ACTION_PROPERTY_REPRESENTATION('spindle speed','turning',#2121,#2500);

/*****
* Application object: TURNING_TECHNOLOGY (#2200)
* INHIBIT_SPINDLE_OVERRIDE: #2200, #2201, #2202, #2203, #2204 ['override not
allowed']
* SYNC_SPINDLE_AND_Z_FEED: #2200, #2205, #2206, #2207, #2208 ['not

```

```

synchronized']
* FEEDRATE_PER_REVOLUTION: #2200, #2209, #2210, #2211, #2212
* FEEDRATE_REFERENCE: #2200, #2213, #2214, #2215, #2216 ['tool center point']
* INHIBIT_FEEDRATE_OVERRIDE: #2200, #2217, #2218, #2219, #2220 ['override not
allowed']
* SPINDLE_SPEED: #2200, #2221, #2222, #2600
*/
#2200=MACHINING_TECHNOLOGY('','turning','','');
#2201=ACTION_PROPERTY('inhibit spindle override','turning',#2200);
#2202=ACTION_PROPERTY_REPRESENTATION('','turning',#2201,#2203);
#2203=REPRESENTATION('',( #2204),#413);
#2204=DESCRIPTIVE_REPRESENTATION_ITEM('','override not allowed');
#2205=ACTION_PROPERTY('synchronize spindle with z feed','turning',#2200);
#2206=ACTION_PROPERTY_REPRESENTATION('','turning',#2205,#2207);
#2207=REPRESENTATION('',( #2208),#413);
#2208=DESCRIPTIVE_REPRESENTATION_ITEM('','not synchronized');
#2209=ACTION_PROPERTY('feedrate','turning',#2200);
#2210=ACTION_PROPERTY_REPRESENTATION('feed per revolution','turning',#2209,
#2211);
#2211=MACHINING_FEED_SPEED_REPRESENTATION('feed per revolution',( #2212),
#413);
#2212=MEASURE_REPRESENTATION_ITEM('feed per revolution',NUMERIC_MEASURE(0.3),
#2023);
#2213=ACTION_PROPERTY('feedrate reference','turning',#2200);
#2214=ACTION_PROPERTY_REPRESENTATION('','turning',#2213,#2215);
#2215=REPRESENTATION('',( #2216),#413);
#2216=DESCRIPTIVE_REPRESENTATION_ITEM('','tool center point');
#2217=ACTION_PROPERTY('inhibit feedrate override','turning',#2200);
#2218=ACTION_PROPERTY_REPRESENTATION('','turning',#2217,#2219);
#2219=REPRESENTATION('',( #2220),#413);
#2220=DESCRIPTIVE_REPRESENTATION_ITEM('','override not allowed');
#2221=ACTION_PROPERTY('spindle','turning',#2200);
#2222=ACTION_PROPERTY_REPRESENTATION('spindle speed','turning',#2221,#2600);

/*****
* Application object: TURNING_TECHNOLOGY (#2300)
* INHIBIT_SPINDLE_OVERRIDE: #2300, #2301, #2302, #2303, #2304 ['override not
allowed']
* SYNC_SPINDLE_AND_Z_FEED: #2300, #2305, #2306, #2307, #2308 ['not
synchronized']
* FEEDRATE_PER_REVOLUTION: #2300, #2309, #2310, #2311, #2312
* FEEDRATE_REFERENCE: #2300, #2313, #2314, #2315, #2316 ['tool center point']
* INHIBIT_FEEDRATE_OVERRIDE: #2300, #2317, #2318, #2319, #2320 ['override not
allowed']
* SPINDLE_SPEED: #2300, #2321, #2322, #2700
*/
#2300=MACHINING_TECHNOLOGY('','turning','','');
#2301=ACTION_PROPERTY('inhibit spindle override','turning',#2300);
#2302=ACTION_PROPERTY_REPRESENTATION('','turning',#2301,#2303);
#2303=REPRESENTATION('',( #2304),#413);
#2304=DESCRIPTIVE_REPRESENTATION_ITEM('','override not allowed');
#2305=ACTION_PROPERTY('synchronize spindle with z feed','turning',#2300);
#2306=ACTION_PROPERTY_REPRESENTATION('','turning',#2305,#2307);
#2307=REPRESENTATION('',( #2308),#413);

```

```

#2308=DESCRIPTIVE_REPRESENTATION_ITEM('','not synchronized');
#2309=ACTION_PROPERTY('feedrate','turning',#2300);
#2310=ACTION_PROPERTY_REPRESENTATION('feed per revolution','turning',#2309,
#2311);
#2311=MACHINING_FEED_SPEED_REPRESENTATION('feed per revolution',(#2312),
#413);
#2312=MEASURE_REPRESENTATION_ITEM('feed per revolution',NUMERIC_MEASURE(0.2),
#2023);
#2313=ACTION_PROPERTY('feedrate reference','turning',#2300);
#2314=ACTION_PROPERTY_REPRESENTATION('','turning',#2313,#2315);
#2315=REPRESENTATION('',( #2316), #413);
#2316=DESCRIPTIVE_REPRESENTATION_ITEM('','tool center point');
#2317=ACTION_PROPERTY('inhibit feedrate override','turning',#2300);
#2318=ACTION_PROPERTY_REPRESENTATION('','turning',#2317,#2319);
#2319=REPRESENTATION('',( #2320), #413);
#2320=DESCRIPTIVE_REPRESENTATION_ITEM('','override not allowed');
#2321=ACTION_PROPERTY('spindle','turning',#2300);
#2322=ACTION_PROPERTY_REPRESENTATION('spindle speed','turning',#2321,#2700);

/*****
* Application object: CONST_SPINDLE_SPEED (#2400)
* ROT_SPEED: #2400, #2401
*/
#2400=MACHINING_SPINDLE_SPEED_REPRESENTATION('spindle speed',(#2401),#413);
#2401=MEASURE_REPRESENTATION_ITEM('rotational speed',NUMERIC_MEASURE(5.),
#2402);
#2402=DERIVED_UNIT((#2403));
#2403=DERIVED_UNIT_ELEMENT(#120,-1.);
#2404=NAME_ATTRIBUTE('revolution/second',#2402);

/*****
* Application object: CONST_CUTTING_SPEED (#2500)
* SPEED: #2500, #2501
* MAX_SPEED: #2500, #2502
*/
#2500=MACHINING_SPINDLE_SPEED_REPRESENTATION('spindle speed',(#2501,#2502),
#413);
#2501=MEASURE_REPRESENTATION_ITEM('surface speed',NUMERIC_MEASURE(2.5),#2023);
#2502=MEASURE_REPRESENTATION_ITEM('maximum rotational
speed',NUMERIC_MEASURE(10.),
#2023);

/*****
* Application object: CONST_CUTTING_SPEED (#2600)
* SPEED: #2600, #2601
* MAX_SPEED: #2600, #2602
*/
#2600=MACHINING_SPINDLE_SPEED_REPRESENTATION('spindle speed',(#2601,#2602),
#413);
#2601=MEASURE_REPRESENTATION_ITEM('surface speed',NUMERIC_MEASURE(2.5),#2023);
#2602=MEASURE_REPRESENTATION_ITEM('maximum rotational
speed',NUMERIC_MEASURE(10.),
#2023);

```

```

/*****
* Application object: CONST_CUTTING_SPEED (#2700)
* SPEED: #2700, #2701
* MAX_SPEED: #2700, #2702
*/
#2700=MACHINING_SPINDLE_SPEED_REPRESENTATION('spindle speed',(#2701,#2702),
#413);
#2701=MEASURE_REPRESENTATION_ITEM('surface speed',NUMERIC_MEASURE(2.2),#2023);
#2702=MEASURE_REPRESENTATION_ITEM('maximum rotational
speed',NUMERIC_MEASURE(10.),
#2023);

/*****
* Application object: UNIDIRECTIONAL_TURNING (#2800)
* LIFT_HEIGHT: #2800, #2801, #2802, #2803, #2804
* CUTTING_DEPTH [*]: #2800, #2805, #2806, #2807, #2808, #2809
* BACK_PATH_DIRECTION: #2800, #2810, #2811, #2812, #2813
*/
#2800=TURNING_TYPE_STRATEGY('','unidirectional','','');
#2801=ACTION_PROPERTY('lift height','unidirectional',#2800);
#2802=ACTION_PROPERTY_REPRESENTATION('','unidirectional',#2801,#2803);
#2803=REPRESENTATION('',( #2804),#413);
#2804=(
LENGTH_MEASURE_WITH_UNIT()
MEASURE_REPRESENTATION_ITEM()
MEASURE_WITH_UNIT(LENGTH_MEASURE(2.),#119)
REPRESENTATION_ITEM('')
);
#2805=ACTION_PROPERTY('cutting depth','unidirectional',#2800);
#2806=ACTION_PROPERTY_REPRESENTATION('','unidirectional',#2805,#2807);
#2807=REPRESENTATION('',( #2808),#);
#2808=COMPOUND_REPRESENTATION_ITEM('',LIST_REPRESENTATION_ITEM((#2809)));
#2809=(
LENGTH_MEASURE_WITH_UNIT()
MEASURE_REPRESENTATION_ITEM()
MEASURE_WITH_UNIT(LENGTH_MEASURE(3.),#119)
REPRESENTATION_ITEM('')
);
#2810=ACTION_PROPERTY('back path direction','unidirectional',#2800);
#2811=ACTION_PROPERTY_REPRESENTATION('','unidirectional',#2810,#2812);
#2812=REPRESENTATION('',( #2813),#413);
#2813=DIRECTION('FACING DIRECTION',(-1.,0.,0.));

/*****
* Application object: UNIDIRECTIONAL_TURNING (#2900)
* LIFT_HEIGHT: #2900, #2901, #2902, #2903, #2904
* CUTTING_DEPTH [*]: #2900, #2905, #2906, #2907, #2908, #2909
* BACK_PATH_DIRECTION: #2900, #2910, #2911, #2912, #2813
*/
#2900=TURNING_TYPE_STRATEGY('','unidirectional','','');
#2901=ACTION_PROPERTY('lift height','unidirectional',#2900);
#2902=ACTION_PROPERTY_REPRESENTATION('','unidirectional',#2901,#2903);
#2903=REPRESENTATION('',( #2904),#413);
#2904=(

```

```

LENGTH_MEASURE_WITH_UNIT()
MEASURE_REPRESENTATION_ITEM()
MEASURE_WITH_UNIT(LENGTH_MEASURE(2.),#119)
REPRESENTATION_ITEM('')
);
#2905=ACTION_PROPERTY('cutting depth','unidirectional',#2900);
#2906=ACTION_PROPERTY_REPRESENTATION('','unidirectional',#2905,#2907);
#2907=REPRESENTATION('',( #2908), $);
#2908=COMPOUND_REPRESENTATION_ITEM('',LIST_REPRESENTATION_ITEM((#2909)));
#2909=(
LENGTH_MEASURE_WITH_UNIT()
MEASURE_REPRESENTATION_ITEM()
MEASURE_WITH_UNIT(LENGTH_MEASURE(0.5),#119)
REPRESENTATION_ITEM('')
);
#2910=ACTION_PROPERTY('back path direction','unidirectional',#2900);
#2911=ACTION_PROPERTY_REPRESENTATION('','unidirectional',#2910,#2912);
#2912=REPRESENTATION('',( #2813), #413);

/*****
* Application object: AP_RETRACT_TANGENT (#3000)
* RADIUS: #3000, #3001, #3002, #3003, #3004
*/
#3000=MACHINING_APPROACH_RETRACT_STRATEGY('','approach retract tangent',
'', '');
#3001=ACTION_PROPERTY('travel radius','approach retract tangent',#3000);
#3002=ACTION_PROPERTY_REPRESENTATION('','approach retract tangent',#3001,
#3003);
#3003=REPRESENTATION('',( #3004), #413);
#3004=(
LENGTH_MEASURE_WITH_UNIT()
MEASURE_REPRESENTATION_ITEM()
MEASURE_WITH_UNIT(LENGTH_MEASURE(60.),#119)
REPRESENTATION_ITEM('')
);

/*****
* Application object: AP_RETRACT_ANGLE (#3100)
* ANGLE: #3100, #3101, #3102, #3103, #3104
* TRAVEL_LENGTH: #3100, #3105, #3106, #3107, #3108
*/
#3100=MACHINING_APPROACH_RETRACT_STRATEGY('','approach retract angle','',
'');
#3101=ACTION_PROPERTY('travel angle','approach retract angle',#3100);
#3102=ACTION_PROPERTY_REPRESENTATION('','approach retract angle',#3101,#3103);
#3103=REPRESENTATION('',( #3104), #413);
#3104=(
MEASURE_REPRESENTATION_ITEM()
MEASURE_WITH_UNIT(PLANE_ANGLE_MEASURE(100.),#114)
PLANE_ANGLE_MEASURE_WITH_UNIT()
REPRESENTATION_ITEM('')
);
#3105=ACTION_PROPERTY('travel length','approach retract angle',#3100);
#3106=ACTION_PROPERTY_REPRESENTATION('','approach retract angle',#3105,#3107);

```

```

#3107=REPRESENTATION('', (#3108), #413);
#3108= (
LENGTH_MEASURE_WITH_UNIT()
MEASURE_REPRESENTATION_ITEM()
MEASURE_WITH_UNIT(LENGTH_MEASURE(2.), #119)
REPRESENTATION_ITEM('')
);

/*****
* Application object: UNIDIRECTIONAL_TURNING (#3200)
* LIFT_HEIGHT: #3200, #3201, #3202, #3203, #3204
* CUTTING_DEPTH [*]: #3200, #3205, #3206, #3207, #3208, #3209
*/
#3200=TURNING_TYPE_STRATEGY('', 'unidirectional', '', '');
#3201=ACTION_PROPERTY('lift height', 'unidirectional', #3200);
#3202=ACTION_PROPERTY_REPRESENTATION('', 'unidirectional', #3201, #3203);
#3203=REPRESENTATION('', (#3204), #413);
#3204= (
LENGTH_MEASURE_WITH_UNIT()
MEASURE_REPRESENTATION_ITEM()
MEASURE_WITH_UNIT(LENGTH_MEASURE(2.), #119)
REPRESENTATION_ITEM('')
);
#3205=ACTION_PROPERTY('cutting depth', 'unidirectional', #3200);
#3206=ACTION_PROPERTY_REPRESENTATION('', 'unidirectional', #3205, #3207);
#3207=REPRESENTATION('', (#3208), $);
#3208=COMPOUND_REPRESENTATION_ITEM('', LIST_REPRESENTATION_ITEM((#3209)));
#3209= (
LENGTH_MEASURE_WITH_UNIT()
MEASURE_REPRESENTATION_ITEM()
MEASURE_WITH_UNIT(LENGTH_MEASURE(3.), #119)
REPRESENTATION_ITEM('')
);

/*****
* Application object: CONTOUR_TURNING (#3300)
* CUTTING_DEPTH [*]: #3300, #3301, #3302, #3303, #3304, #3305
* LIFT_DIRECTION: #3300, #3306, #3307, #3308, #3309
*/
#3300=TURNING_TYPE_STRATEGY('', 'contour', '', '');
#3301=ACTION_PROPERTY('cutting depth', 'contour', #3300);
#3302=ACTION_PROPERTY_REPRESENTATION('', 'contour', #3301, #3303);
#3303=REPRESENTATION('', (#3304), $);
#3304=COMPOUND_REPRESENTATION_ITEM('', LIST_REPRESENTATION_ITEM((#3305)));
#3305= (
LENGTH_MEASURE_WITH_UNIT()
MEASURE_REPRESENTATION_ITEM()
MEASURE_WITH_UNIT(LENGTH_MEASURE(0.5), #119)
REPRESENTATION_ITEM('')
);
#3306=ACTION_PROPERTY('lift direction', 'contour', #3300);
#3307=ACTION_PROPERTY_REPRESENTATION('', 'contour', #3306, #3308);
#3308=REPRESENTATION('', (#3309), #413);
#3309=DIRECTION('STEPOVER DIRECTION FOR CONTOUR', (1., 0., 0.));

```

```

/*****
* Application object: AP_RETRACT_ANGLE (#3400)
* ANGLE: #3400, #3401, #3402, #3403, #3404
* TRAVEL_LENGTH: #3400, #3405, #3406, #3407, #3408
*/
#3400=MACHINING_APPROACH_RETRACT_STRATEGY('', 'approach retract angle', '',
'');
#3401=ACTION_PROPERTY('travel angle', 'approach retract angle', #3400);
#3402=ACTION_PROPERTY_REPRESENTATION('', 'approach retract angle', #3401, #3403);
#3403=REPRESENTATION('', (#3404), #413);
#3404= (
MEASURE_REPRESENTATION_ITEM()
MEASURE_WITH_UNIT(PLANE_ANGLE_MEASURE(45.), #114)
PLANE_ANGLE_MEASURE_WITH_UNIT()
REPRESENTATION_ITEM('')
);
#3405=ACTION_PROPERTY('travel length', 'approach retract angle', #3400);
#3406=ACTION_PROPERTY_REPRESENTATION('', 'approach retract angle', #3405, #3407);
#3407=REPRESENTATION('', (#3408), #413);
#3408= (
LENGTH_MEASURE_WITH_UNIT()
MEASURE_REPRESENTATION_ITEM()
MEASURE_WITH_UNIT(LENGTH_MEASURE(4.), #119)
REPRESENTATION_ITEM('')
);

/*****
* Application object: TOLERANCED_LENGTH_MEASURE (#3500)
* VALUE_COMPONENT: #3500 [80]
*****
* Application object: QUALIFIED_PLUS_MINUS_VALUE (#3500)
* LOWER_LIMIT: #3500, #3501 [0.1]
* UPPER_LIMIT: #3500, #3502 [0.1]
*/
#3500= (
LENGTH_MEASURE_WITH_UNIT()
MEASURE_REPRESENTATION_ITEM()
MEASURE_WITH_UNIT(LENGTH_MEASURE(80.), #119)
QUALIFIED_REPRESENTATION_ITEM((#3501, #3502))
REPRESENTATION_ITEM('diameter')
);
#3501=STANDARD_UNCERTAINTY('lower limit', '', 0.1);
#3502=STANDARD_UNCERTAINTY('upper limit', '', 0.1);

/*****
* Application object: TOLERANCED_LENGTH_MEASURE (#3600)
* VALUE_COMPONENT: #3600 [110]
*****
* Application object: QUALIFIED_PLUS_MINUS_VALUE (#3600)
* LOWER_LIMIT: #3600, #3601 [0.1]
* UPPER_LIMIT: #3600, #3602 [0.1]
*/
#3600= (

```



```

LENGTH_MEASURE_WITH_UNIT()
MEASURE_REPRESENTATION_ITEM()
MEASURE_WITH_UNIT(LENGTH_MEASURE(110.),#119)
QUALIFIED_REPRESENTATION_ITEM((#3601,#3602))
REPRESENTATION_ITEM('length')
);
#3601=STANDARD_UNCERTAINTY('lower limit','',0.1);
#3602=STANDARD_UNCERTAINTY('upper limit','',0.1);

/*****
* Application object: TOLERANCED_LENGTH_MEASURE (#3700)
* VALUE_COMPONENT: #3700 [40]
*****
* Application object: QUALIFIED_PLUS_MINUS_VALUE (#3700)
* LOWER_LIMIT: #3700, #3701 [0]
* UPPER_LIMIT: #3700, #3702 [0.2]
*/
#3700=(
LENGTH_MEASURE_WITH_UNIT()
MEASURE_REPRESENTATION_ITEM()
MEASURE_WITH_UNIT(LENGTH_MEASURE(40.),#119)
QUALIFIED_REPRESENTATION_ITEM((#3701,#3702))
REPRESENTATION_ITEM('diameter')
);
#3701=STANDARD_UNCERTAINTY('lower limit','',0.);
#3702=STANDARD_UNCERTAINTY('upper limit','',0.2);

/*****
* Application object: LINEAR_PROFILE (#3800)
* PROFILE_LENGTH: #3800, #3801, #3802, #3803, #3900
*/
#3800=LINEAR_PROFILE('','flat edge shape',#3805,.F.);
#3801=PRODUCT_DEFINITION_SHAPE('profile length','',#3800);
#3802=SHAPE_DEFINITION_REPRESENTATION(#3801,#3803);
#3803=SHAPE_REPRESENTATION_WITH_PARAMETERS('',( #3900),#113);
#3804=FEATURE_COMPONENT_DEFINITION('feature component','shared by all');
#3805=PRODUCT_DEFINITION_SHAPE('feature component',$,#3804);

/*****
* Application object: NUMERIC_PARAMETER (#3900)
* ITS_PARAMETER_VALUE: #3900 [20]
* ITS_PARAMETER_UNIT: #3900, #119
* PARAMETER_NAME: #3900 ['LINEAR PROFILE LENGTH']
*/
#3900=MEASURE_REPRESENTATION_ITEM('LINEAR PROFILE LENGTH',NUMERIC_MEASURE(20.),
#119);

/*****
* Application object: TOLERANCED_LENGTH_MEASURE (#4000)
* VALUE_COMPONENT: #4000 [50]
*****
* Application object: QUALIFIED_PLUS_MINUS_VALUE (#4000)
* LOWER_LIMIT: #4000, #4001 [0.1]
* UPPER_LIMIT: #4000, #4002 [0.1]

```

```

*/
#4000= (
LENGTH_MEASURE_WITH_UNIT()
MEASURE_REPRESENTATION_ITEM()
MEASURE_WITH_UNIT(LENGTH_MEASURE(50.),#119)
QUALIFIED_REPRESENTATION_ITEM((#4001,#4002))
REPRESENTATION_ITEM('length')
);
#4001=STANDARD_UNCERTAINTY('lower limit','',0.1);
#4002=STANDARD_UNCERTAINTY('upper limit','',0.1);

/*****
* Application object: DIAMETER_TAPER (#4100)
* FINAL_DIAMETER: #4100, #4101, #4102, #4103, #4200
*/
#4100=TAPER('','diameter taper',#4104,.F.);
#4101=PRODUCT_DEFINITION_SHAPE('final diameter','diameter taper',#4100);
#4102=SHAPE_DEFINITION_REPRESENTATION(#4101,#4103);
#4103=SHAPE_REPRESENTATION_WITH_PARAMETERS('',( #4200),#113);
#4104=PRODUCT_DEFINITION_SHAPE('','diameter taper',#4105);
#4105=FEATURE_COMPONENT_DEFINITION('','diameter taper');

/*****
* Application object: TOLERANCED_LENGTH_MEASURE (#4200)
* VALUE_COMPONENT: #4200 [80]
*****
* Application object: QUALIFIED_PLUS_MINUS_VALUE (#4200)
* LOWER_LIMIT: #4200, #4201 [0.1]
* UPPER_LIMIT: #4200, #4202 [0.1]
*/
#4200= (
LENGTH_MEASURE_WITH_UNIT()
MEASURE_REPRESENTATION_ITEM()
MEASURE_WITH_UNIT(LENGTH_MEASURE(80.),#119)
QUALIFIED_REPRESENTATION_ITEM((#4201,#4202))
REPRESENTATION_ITEM('final diameter')
);
#4201=STANDARD_UNCERTAINTY('lower limit','',0.1);
#4202=STANDARD_UNCERTAINTY('upper limit','',0.1);

/*****
* Application object: GENERAL_TURNING_TOOL (#4300)
* ITS_ID: #4300 ['ROUGHING TOOL']
* FUNCTIONAL_LENGTH: #4300, #4301, #4302, #4400, #4402 [120]
* F_DIMENSION: #4300, #4301, #4302, #4400, #4403 [45]
* CUTTING_EDGE: #4300, #4404, #4450
* HAND_OF_TOOL: #4300, #4301, #4302, #4400, #4401 ['left']
*/
#4300=MACHINING_TOOL('ROUGHING TOOL','general turning tool',
(#900,#700),#4303);
#4301=RESOURCE_PROPERTY('tool body','',#4300);
#4302=RESOURCE_PROPERTY_REPRESENTATION('','',#4301,#4400);
#4303=ACTION_RESOURCE_TYPE('turning cutting tool');

```

```

#4400=MACHINING_TOOL_BODY_REPRESENTATION('', (#4401, #4402, #4403), #413);
#4401=DESCRIPTIVE_REPRESENTATION_ITEM('hand of cut', 'left');
#4402=(
LENGTH_MEASURE_WITH_UNIT()
MEASURE_REPRESENTATION_ITEM()
MEASURE_WITH_UNIT(LENGTH_MEASURE(120.), #119)
REPRESENTATION_ITEM('functional length')
);
#4403=(
LENGTH_MEASURE_WITH_UNIT()
MEASURE_REPRESENTATION_ITEM()
MEASURE_WITH_UNIT(LENGTH_MEASURE(45.), #119)
REPRESENTATION_ITEM('f dimension')
);
#4404=ACTION_RESOURCE_RELATIONSHIP('', $, #4300, #4450);

/*****
* Application object: CUTTING_EDGE_PROPERTIES (#4450)
* ITS_MATERIAL: #4450, #4500
* CUTTING_EDGE_LENGTH: #4450, #4453, #4454, #4455, #4456 [10.0]
* TOOL_CUTTING_EDGE_ANGLE: #4450, #4457, #4458, #4459, #4460 [110.0]
* TOOL_INCLUDED_ANGLE: #4450, #4461, #4462, #4463, #4464 [25.0]
*/
#4450=MACHINING_CUTTING_COMPONENT('', '', (), #4452, '$);
#4452=ACTION_RESOURCE_TYPE('turning cutting edge');

#4453=RESOURCE_PROPERTY('cutting edge length', '', #4450);
#4454=RESOURCE_PROPERTY_REPRESENTATION('', '', #4453, #4455);
#4455=REPRESENTATION('', (#4456), #413);
#4456=(
LENGTH_MEASURE_WITH_UNIT()
MEASURE_REPRESENTATION_ITEM()
MEASURE_WITH_UNIT(LENGTH_MEASURE(10.), #119)
REPRESENTATION_ITEM('')
);

#4457=RESOURCE_PROPERTY('cutting edge angle', '', #4450);
#4458=RESOURCE_PROPERTY_REPRESENTATION('', '', #4457, #4459);
#4459=REPRESENTATION('', (#4460), #413);
#4460=(
MEASURE_REPRESENTATION_ITEM()
MEASURE_WITH_UNIT(PLANE_ANGLE_MEASURE(110.), #114)
PLANE_ANGLE_MEASURE_WITH_UNIT()
REPRESENTATION_ITEM('')
);

#4461=RESOURCE_PROPERTY('tool included angle', '', #4450);
#4462=RESOURCE_PROPERTY_REPRESENTATION('', '', #4461, #4463);
#4463=REPRESENTATION('', (#4464), #413);
#4464=(
MEASURE_REPRESENTATION_ITEM()
MEASURE_WITH_UNIT(PLANE_ANGLE_MEASURE(25.), #114)
PLANE_ANGLE_MEASURE_WITH_UNIT()
REPRESENTATION_ITEM('')
);

```

);

```

/*****
* Application object: MATERIAL (#4500)
* MATERIAL_IDENTIFIER: #4500 ['TIN']
* STANDARD_IDENTIFIER: #4500, #4501, #4502 ['TIN']
*/
#4500=MATERIAL_DESIGNATION('TIN',(#4450));
#4501=APPLIED_DOCUMENT_REFERENCE(#4502,'',(#4500));
#4502=DOCUMENT('TIN','',',,$);

/*****
* Application object: GENERAL_TURNING_TOOL (#4600)
* ITS_ID: #4600 ['FINISHING TOOL']
* FUNCTIONAL_LENGTH: #4600, #4601, #4602, #4700, #4702 [120]
* F_DIMENSION: #4600, #4601, #4602, #4700, #4703 [45]
* CUTTING_EDGE: #4600, #4704, #4750
* HAND_OF_TOOL: #4600, #4601, #4602, #4700, #4701 ['left']
*/
#4600=MACHINING_TOOL('FINISHING TOOL','general turning tool',
    (#1000,#800),#4303);
#4601=RESOURCE_PROPERTY('tool body','',#4600);
#4602=RESOURCE_PROPERTY_REPRESENTATION('','',#4601,#4700);

#4700=MACHINING_TOOL_BODY_REPRESENTATION('',( #4701,#4702,#4703),#413);
#4701=DESCRIPTIVE_REPRESENTATION_ITEM('hand of cut','left');
#4702=(
LENGTH_MEASURE_WITH_UNIT()
MEASURE_REPRESENTATION_ITEM()
MEASURE_WITH_UNIT(LENGTH_MEASURE(120.0),#119)
REPRESENTATION_ITEM('functional length')
);
#4703=(
LENGTH_MEASURE_WITH_UNIT()
MEASURE_REPRESENTATION_ITEM()
MEASURE_WITH_UNIT(LENGTH_MEASURE(45.),#119)
REPRESENTATION_ITEM('f dimension')
);
#4704=ACTION_RESOURCE_RELATIONSHIP('',$,#4600,#4750);

/*****
* Application object: CUTTING_EDGE_PROPERTIES (#4750)
* ITS_MATERIAL: #4750, #4800
* CUTTING_EDGE_LENGTH: #4750, #4753, #4754, #4755, #4756 [15.0]
* TOOL_CUTTING_EDGE_ANGLE: #4750, #4757, #4758, #4759, #4760 [110.0]
* TOOL_INCLUDED_ANGLE: #4750, #4761, #4762, #4763, #4764 [15.0]
*/
#4750=MACHINING_CUTTING_COMPONENT('','',(),#4452,'',$);
#4753=RESOURCE_PROPERTY('cutting edge length','',#4750);
#4754=RESOURCE_PROPERTY_REPRESENTATION('','',#4753,#4755);
#4755=REPRESENTATION('',( #4756),#413);
#4756=(

```

```

LENGTH_MEASURE_WITH_UNIT()
MEASURE_REPRESENTATION_ITEM()
MEASURE_WITH_UNIT(LENGTH_MEASURE(15.),#119)
REPRESENTATION_ITEM('')
);

#4757=RESOURCE_PROPERTY('cutting edge angle','',#4750);
#4758=RESOURCE_PROPERTY_REPRESENTATION('','',#4757,#4759);
#4759=REPRESENTATION('',( #4760),#413);
#4760=(
MEASURE_REPRESENTATION_ITEM()
MEASURE_WITH_UNIT(PLANE_ANGLE_MEASURE(110.),#114)
PLANE_ANGLE_MEASURE_WITH_UNIT()
REPRESENTATION_ITEM('')
);

#4761=RESOURCE_PROPERTY('tool included angle','',#4750);
#4762=RESOURCE_PROPERTY_REPRESENTATION('','',#4761,#4763);
#4763=REPRESENTATION('',( #4764),#413);
#4764=(
MEASURE_REPRESENTATION_ITEM()
MEASURE_WITH_UNIT(PLANE_ANGLE_MEASURE(15.),#114)
PLANE_ANGLE_MEASURE_WITH_UNIT()
REPRESENTATION_ITEM('')
);

/*****
* Application object: MATERIAL (#4800)
* MATERIAL_IDENTIFIER: #4800 ['TIN']
* STANDARD_IDENTIFIER: #4800, #4801, #4802 ['TIN']
*/
#4800=MATERIAL_DESIGNATION('TIN',(#4750));
#4801=APPLIED_DOCUMENT_REFERENCE(#4802,'',( #4800));
#4802=DOCUMENT('TIN','', '$');
ENDSEC;
END-ISO-10303-21;

```

## Bibliography

- [1] ISO 2692:2006, *Geometrical product specifications (GPS) — Geometrical tolerancing — Maximum material requirement (MMR), least material requirement (LMR) and reciprocity requirement (RPR)*
- [2] ISO 6983-1:1982, *Numerical control of machines — Program format and definition of address words — Part 1: Data format for positioning, line motion and contouring control systems*
- [3] ISO 5458:1998, *Geometrical Product Specifications (GPS) — Geometrical tolerancing — Positional tolerancing*
- [4] ISO 10303-203, *Industrial automation systems and integration — Product data representation and exchange — Part 203: Application protocol: Configuration controlled 3D designs of mechanical parts and assemblies*
- [5] ISO 10303-214, *Industrial automation systems and integration — Product data representation and exchange — Part 214: Application protocol: Core data for automotive mechanical design processes*
- [6] ISO 10303-219<sup>1)</sup>, *Industrial automation systems and integration — Product data representation and exchange — Part 219: Application protocol: Dimensional inspection information exchange*
- [7] ISO 10303-223<sup>1)</sup>, *Industrial automation systems and integration — Product data representation and exchange — Part 223: Application protocol: Exchange of design and manufacturing product information for casting parts*
- [8] ISO 10303-224, *Industrial automation systems and integration — Product data representation and exchange — Part 224: Application protocol: Mechanical product definition for process planning using machining features*
- [9] ISO 10303-240, *Industrial automation systems and integration — Product data representation and exchange — Part 240: Application protocol: Process plans for machined products*
- [10] ISO 10303-1012, *Industrial automation systems and integration — Product data representation and exchange — Part 1012: Application module: Approval*
- [11] ISO 10303-1013, *Industrial automation systems and integration — Product data representation and exchange — Part 1013: Application module: Person organization assignment*
- [12] ISO 10303-1014, *Industrial automation systems and integration — Product data representation and exchange — Part 1014: Application module: Date time assignment*
- [13] ISO 10303-1015, *Industrial automation systems and integration — Product data representation and exchange — Part 1015: Application module: Security classification*

---

1) To be published.

- [14] ISO 10303-1031<sup>1)</sup>, *Industrial automation systems and integration — Product data representation and exchange — Part 1031: Application module: Property representation*
- [15] ISO 10303-1050, *Industrial automation systems and integration — Product data representation and exchange — Part 1050: Application module: Dimension tolerance*
- [16] ISO 10303-1051, *Industrial automation systems and integration — Product data representation and exchange — Part 1051: Application module: Geometric tolerance*
- [17] ISO 10303-1054, *Industrial automation systems and integration — Product data representation and exchange — Part 1054: Application module: Value with unit*
- [18] ISO 10303-1106, *Industrial automation systems and integration — Product data representation and exchange — Part 1106: Application module: Extended measure representation*
- [19] ISO 13399-1:2006, *Cutting tool data representation and exchange — Part 1: Overview, fundamental principles and general information model*

---

1) Under preparation.

## Index

action	
AIM diagrams	1351
AIM EXPRESS listing entities	1006
action_method	
AIM diagrams	1347
AIM EXPRESS listing entities	1006
action_method_relationship	
AIM diagrams	1349
AIM EXPRESS listing entities	1006
action_method_with_associated_documents	
AIM diagrams	1347
AIM EXPRESS listing entities	1006
action_property	
AIM diagrams	1354
AIM EXPRESS listing entities	1006
action_property_representation	
AIM diagrams	1354
AIM EXPRESS listing entities	1006
action_relationship	
AIM diagrams	1354
AIM EXPRESS listing entities	1007
action_resource	
AIM diagrams	1352
AIM EXPRESS listing entities	1007
action_resource_relationship	
AIM diagrams	1352
AIM EXPRESS listing entities	1007
action_resource_requirement	
AIM diagrams	1353
AIM EXPRESS listing entities	1007
action_resource_requirement_relationship	
AIM diagrams	1353
AIM EXPRESS listing entities	1007
action_resource_type	
AIM diagrams	1352
AIM EXPRESS listing entities	1007
acyclic	
AIM EXPRESS listing functions	1218
acyclic_curve_replica	
AIM EXPRESS listing functions	1219
acyclic_mapped_representation	
AIM EXPRESS listing functions	1219
acyclic_point_replica	
AIM EXPRESS listing functions	1219
acyclic_product_category_relationship	
AIM EXPRESS listing functions	1220
acyclic_product_definition_relationship	



AIM EXPRESS listing functions .....	1220
acyclic_surface_replica	
AIM EXPRESS listing functions .....	1221
adaptive_control	
application object .....	19, 30
ARM diagrams .....	1307
mapping specification .....	503
address	
AIM diagrams .....	1401
AIM EXPRESS listing entities .....	1007
ARM diagrams .....	1342
advanced_brep_shape_representation	
AIM diagrams .....	1365
AIM EXPRESS listing entities .....	1008
ARM diagrams .....	1344
advanced_face	
AIM diagrams .....	1382
AIM EXPRESS listing entities .....	1008
ARM diagrams .....	1343
ahead_or_behind	
AIM diagrams .....	1402
AIM EXPRESS listing types .....	996
air_strategy	
application object .....	19, 30
ARM diagrams .....	1312
mapping specification .....	503
along_path	
application object .....	19, 30
ARM diagrams .....	1312
mapping specification .....	503
and_expression	
AIM diagrams .....	1398
AIM EXPRESS listing entities .....	1010
application object .....	15, 31
ARM diagrams .....	1334
mapping specification .....	420
angle_relator	
AIM diagrams .....	1391
AIM EXPRESS listing types .....	996
angle_taper	
application object .....	10, 31
ARM diagrams .....	1322
mapping specification .....	243
angular_location	
AIM diagrams .....	1388
AIM EXPRESS listing entities .....	1010
angular_location_dimension	
application object .....	26, 31
ARM diagrams .....	1330

mapping specification .....	718
angular_size	
AIM diagrams .....	1391
AIM EXPRESS listing entities .....	1010
angular_size_dimension	
application object .....	26, 32
ARM diagrams .....	1330
mapping specification .....	718
angularity_tolerance	
AIM diagrams .....	1390
AIM EXPRESS listing entities .....	1010
application assertion .....	195
application object .....	26, 33
ARM diagrams .....	1331
mapping specification .....	719
ap_lift_path_angle	
application object .....	18, 34
ARM diagrams .....	1302
mapping specification .....	479
ap_lift_path_tangent	
application object .....	18, 34
ARM diagrams .....	1302
mapping specification .....	480
ap_retract_angle	
application object .....	19, 34
ARM diagrams .....	1312
mapping specification .....	503
ap_retract_tangent	
application object .....	19, 35
ARM diagrams .....	1312
mapping specification .....	505
apex	
AIM diagrams .....	1388
AIM EXPRESS listing entities .....	1010
application .....	5
application activity model (AAM) .....	5
application interpreted model (AIM) .....	5
application object .....	5
application protocol (AP) .....	5
application reference model (ARM) .....	5
application_context	
AIM diagrams .....	1358
AIM EXPRESS listing entities .....	1010
AIM EXPRESS short listing imported entity modifications .....	924
application_context_element	
AIM diagrams .....	1358
AIM EXPRESS listing entities .....	1011
application_context_requires_ap_definition	
AIM EXPRESS listing rules .....	1213

AIM EXPRESS short listing rules .....	929
application_protocol_definition	
AIM diagrams .....	1358
AIM EXPRESS listing entities .....	1011
AIM EXPRESS short listing imported entity modifications .....	924
applied_approval_assignment	
AIM diagrams .....	1406
AIM EXPRESS listing entities .....	1011
AIM EXPRESS short listing entities .....	810
applied_area	
AIM diagrams .....	1386
AIM EXPRESS listing entities .....	1011
applied_classification_assignment	
AIM diagrams .....	1408
AIM EXPRESS listing entities .....	1012
AIM EXPRESS short listing entities .....	811
applied_date_and_time_assignment	
AIM diagrams .....	1403
AIM EXPRESS listing entities .....	1012
AIM EXPRESS short listing entities .....	811
applied_date_assignment	
AIM diagrams .....	1403
AIM EXPRESS listing entities .....	1012
AIM EXPRESS short listing entities .....	811
applied_document_reference	
AIM diagrams .....	1405
AIM EXPRESS listing entities .....	1013
AIM EXPRESS short listing entities .....	812
applied_document_usage_constraint_assignment	
AIM diagrams .....	1405
AIM EXPRESS listing entities .....	1013
AIM EXPRESS short listing entities .....	812
applied_external_identification_assignment	
AIM diagrams .....	1363
AIM EXPRESS listing entities .....	1013
AIM EXPRESS short listing entities .....	812
applied_identification_assignment	
AIM diagrams .....	1363
AIM EXPRESS listing entities .....	1013
AIM EXPRESS short listing entities .....	813
applied_organization_assignment	
AIM diagrams .....	1400
AIM EXPRESS listing entities .....	1013
AIM EXPRESS short listing entities .....	813
applied_person_and_organization_assignment	
AIM diagrams .....	1399
AIM EXPRESS listing entities .....	1013
AIM EXPRESS short listing entities .....	813
applied_security_classification_assignment	

AIM diagrams	1407
AIM EXPRESS listing entities	1013
AIM EXPRESS short listing entities	814
approach_lift_path	
application object	18, 35
ARM diagrams	1302
mapping specification	481
approach_retract_strategy	
application object	19, 35
ARM diagrams	1312
mapping specification	505
approval	
AIM diagrams	1406
AIM EXPRESS listing entities	1013
AIM EXPRESS short listing imported entity modifications	925
application assertion	195, 203
application object	29, 35
ARM diagrams	1338
mapping specification	758
approval_assignment	
AIM diagrams	1406
AIM EXPRESS listing entities	1013
AIM EXPRESS short listing imported entity modifications	925
approval_date_time	
AIM diagrams	1406
AIM EXPRESS listing entities	1013
approval_item	
AIM diagrams	1406
AIM EXPRESS listing types	996
AIM EXPRESS short listing types	807
approval_person_organization	
AIM diagrams	1406
AIM EXPRESS listing entities	1014
AIM EXPRESS short listing imported entity modifications	925
approval_relationship	
AIM diagrams	1406
AIM EXPRESS listing entities	1014
application assertion	195
application object	29, 36
ARM diagrams	1338
mapping specification	758
approval_requires_approval_person_organization	
AIM EXPRESS listing rules	1214
AIM EXPRESS short listing rules	929
approval_requires_assignment	
AIM EXPRESS listing rules	1214
AIM EXPRESS short listing rules	930
approval_role	
AIM diagrams	1406

AIM EXPRESS listing entities .....	1014
approval_status	
AIM diagrams .....	1406
AIM EXPRESS listing entities .....	1014
AIM EXPRESS short listing imported entity modifications .....	925
application assertion .....	195
application object .....	29, 37
ARM diagrams .....	1338
mapping specification .....	759
approving_person_organization	
application assertion .....	195
application object .....	29, 38
ARM diagrams .....	1338
mapping specification .....	759
area_measure	
AIM diagrams .....	1394
AIM EXPRESS listing types .....	996
application object .....	8, 39
ARM diagrams .....	1341
mapping specification .....	207
assembly_component_usage	
AIM diagrams .....	1359
AIM EXPRESS listing entities .....	1014
assigned_date	
application assertion .....	203
application object .....	29, 39
ARM diagrams .....	1337
mapping specification .....	760
assigned_organization	
application assertion .....	203
application object .....	29, 39
ARM diagrams .....	1337
mapping specification .....	760
assigned_person	
application assertion .....	204
application object .....	29, 40
ARM diagrams .....	1337
mapping specification .....	761
assigned_time	
application assertion .....	204
application object .....	29, 40
ARM diagrams .....	1337
mapping specification .....	761
assignment	
application object .....	15, 41
ARM diagrams .....	1298
mapping specification .....	420
associated_surface	
AIM EXPRESS listing functions .....	1221

axis_placement	
ARM diagrams	1332
axis_trajectory	
application object	18, 41
ARM diagrams	1303
mapping specification	482
axis1_placement	
AIM diagrams	1372
AIM EXPRESS listing entities	1014
axis2_placement	
AIM diagrams	1372
AIM EXPRESS listing types	996
axis2_placement_2d	
AIM diagrams	1372
AIM EXPRESS listing entities	1014
axis2_placement_3d	
AIM diagrams	1372
AIM EXPRESS listing entities	1015
ARM diagrams	1343
b_spline_curve	
AIM diagrams	1381
AIM EXPRESS listing entities	1015
ARM diagrams	1343
b_spline_curve_form	
AIM diagrams	1381
AIM EXPRESS listing types	996
b_spline_curve_with_knots	
AIM diagrams	1381
AIM EXPRESS listing entities	1015
b_spline_surface	
AIM diagrams	1375
AIM EXPRESS listing entities	1016
b_spline_surface_form	
AIM diagrams	1375
AIM EXPRESS listing types	997
b_spline_surface_with_knots	
AIM diagrams	1375
AIM EXPRESS listing entities	1016
back_boring	
application object	19, 42
ARM diagrams	1305
mapping specification	506
back_boring_operation	
AIM diagrams	1348
AIM EXPRESS listing entities	1016
AIM EXPRESS short listing entities	814
bag_to_set	
AIM EXPRESS listing functions	1221
ballnose_endmill	

application object .....	22, 42
ARM diagrams .....	1315
mapping specification .....	587
base_axis	
AIM EXPRESS listing functions .....	1221
bezier_curve	
AIM diagrams .....	1381
AIM EXPRESS listing entities .....	1017
bezier_surface	
AIM diagrams .....	1375
AIM EXPRESS listing entities .....	1017
bidirectional	
application object .....	19, 42
ARM diagrams .....	1309
mapping specification .....	506
bidirectional_contour	
application object .....	19, 43
ARM diagrams .....	1309
mapping specification .....	508
bidirectional_turning	
application object .....	24, 43
ARM diagrams .....	1311
mapping specification .....	648
binary_boolean_expression	
AIM diagrams .....	1398
AIM EXPRESS listing entities .....	1017
application object .....	15, 43
ARM diagrams .....	1334
mapping specification .....	421
binary_generic_expression	
AIM diagrams .....	1397
AIM EXPRESS listing entities .....	1017
blind_bottom_condition	
application object .....	10, 43
ARM diagrams .....	1322
mapping specification .....	244
block	
AIM diagrams .....	1377
AIM EXPRESS listing entities .....	1017
ARM diagrams .....	1343
block_shape_representation	
AIM diagrams .....	1365
AIM EXPRESS listing entities .....	1017
AIM EXPRESS short listing entities .....	815
boolean_choose	
AIM EXPRESS listing functions .....	1222
boolean_expression	
AIM diagrams .....	1398
AIM EXPRESS listing entities .....	1017

application object .....	15, 44
ARM diagrams .....	1334
mapping specification .....	422
boring	
application object .....	19, 44
ARM diagrams .....	1305
mapping specification .....	511
boring_operation	
AIM diagrams .....	1348
AIM EXPRESS listing entities .....	1018
AIM EXPRESS short listing entities .....	816
application object .....	19, 44
ARM diagrams .....	1305
mapping specification .....	511
boss	
AIM diagrams .....	1387
AIM EXPRESS listing entities .....	1018
application object .....	10, 44
ARM diagrams .....	1323
mapping specification .....	244
boss_top	
AIM diagrams .....	1386
AIM EXPRESS listing entities .....	1021
bottom_and_side_finish_milling	
application object .....	19, 45
ARM diagrams .....	1304
mapping specification .....	514
bottom_and_side_milling	
application object .....	19, 45
ARM diagrams .....	1304
mapping specification .....	514
bottom_and_side_milling_operation	
AIM diagrams .....	1348
AIM EXPRESS listing entities .....	1022
AIM EXPRESS short listing entities .....	817
bottom_and_side_rough_milling	
application object .....	20, 46
ARM diagrams .....	1304
mapping specification .....	518
bottom_or_side	
ARM diagrams .....	1336
boundary_curve	
AIM diagrams .....	1380
AIM EXPRESS listing entities .....	1022
bounded_curve	
AIM diagrams .....	1378
AIM EXPRESS listing entities .....	1022
ARM diagrams .....	1343
bounded_pcurve	



AIM diagrams	1379
AIM EXPRESS listing entities	1022
ARM diagrams	1343
bounded_surface	
AIM diagrams	1374
AIM EXPRESS listing entities	1023
ARM diagrams	1343
bounded_surface_curve	
AIM diagrams	1379
AIM EXPRESS listing entities	1023
bounding_geometry_select	
ARM diagrams	1340
brep_with_voids	
AIM diagrams	1384
AIM EXPRESS listing entities	1023
bsu	
application object	29, 46
ARM diagrams	1313
mapping specification	750
build_2axes	
AIM EXPRESS listing functions	1223
build_axes	
AIM EXPRESS listing functions	1223
bullnose_endmill	
application object	22, 46
ARM diagrams	1315
mapping specification	587
calendar_date	
AIM diagrams	1402
AIM EXPRESS listing entities	1023
cartesian_point	
AIM diagrams	1371
AIM EXPRESS listing entities	1023
ARM diagrams	1343
cartesian_transformation_operator	
AIM diagrams	1369
AIM EXPRESS listing entities	1023
cartesian_transformation_operator_3d	
AIM diagrams	1369
AIM EXPRESS listing entities	1023
catalogue_thread	
application object	10, 46
ARM diagrams	1325
mapping specification	248
center_drilling	
application object	20, 47
ARM diagrams	1305
mapping specification	518
center_milling	

application object	20, 47
ARM diagrams	1309
mapping specification	518
centre_of_symmetry	
AIM diagrams	1388
AIM EXPRESS listing entities	1024
chamfer	
AIM diagrams	1386
AIM EXPRESS listing entities	1024
AIM EXPRESS short listing imported entity modifications	926
application object	10, 47
ARM diagrams	1320
mapping specification	249
chamfer_offset	
AIM diagrams	1386
AIM EXPRESS listing entities	1024
chamfer_requires_faces_or_features	
AIM EXPRESS listing rules	1214
AIM EXPRESS short listing rules	930
chamfered_corner	
application object	26, 48
ARM diagrams	1317
mapping specification	689
channel	
application object	15, 48
ARM diagrams	1298
mapping specification	422
characterized_action_definition	
AIM diagrams	1354
AIM EXPRESS listing types	997
characterized_definition	
AIM diagrams	1360
AIM EXPRESS listing types	997
characterized_material_property	
AIM diagrams	1361
AIM EXPRESS listing types	997
characterized_object	
AIM diagrams	1387
AIM EXPRESS listing entities	1026
characterized_product_definition	
AIM diagrams	1360
AIM EXPRESS listing types	997
characterized_resource_definition	
AIM diagrams	1355
AIM EXPRESS listing types	997
circle	
AIM diagrams	1379
AIM EXPRESS listing entities	1026
circular_closed_profile	

AIM diagrams	1386
AIM EXPRESS listing entities	1026
application object	10, 49
ARM diagrams	1327
mapping specification	254
circular_closed_shape_profile	
application object	10, 49
ARM diagrams	1324
mapping specification	256
circular_offset	
application object	11, 49
ARM diagrams	1321
mapping specification	257
circular_omit	
application object	11, 49
ARM diagrams	1321
mapping specification	259
circular_path	
application object	11, 50
ARM diagrams	1329
mapping specification	260
circular_pattern	
AIM diagrams	1387
AIM EXPRESS listing entities	1027
application object	11, 50
ARM diagrams	1321
mapping specification	261
circular_runout_tolerance	
AIM diagrams	1390
AIM EXPRESS listing entities	1029
application assertion	196
application object	26, 50
ARM diagrams	1331
mapping specification	719
class	
AIM diagrams	1362
AIM EXPRESS listing entities	1029
AIM EXPRESS short listing entities	818
class_bsu	
application assertion	196, 198, 200
application object	29, 51
ARM diagrams	1313
mapping specification	750
classification_assignment	
AIM diagrams	1408
AIM EXPRESS listing entities	1029
classification_item	
AIM diagrams	1408
AIM EXPRESS listing types	997

AIM EXPRESS short listing types .....	807
classification_role	
AIM diagrams .....	1408
AIM EXPRESS listing entities .....	1029
closed_path_profile	
AIM diagrams .....	1386
AIM EXPRESS listing entities .....	1029
closed_pocket	
application object .....	11, 52
ARM diagrams .....	1323
mapping specification .....	267
closed_profile	
application object .....	11, 52
ARM diagrams .....	1327
mapping specification .....	268
closed_shell	
AIM diagrams .....	1384
AIM EXPRESS listing entities .....	1030
closed_shell_reversed	
AIM EXPRESS listing functions .....	1223
coaxiality_tolerance	
AIM diagrams .....	1390
AIM EXPRESS listing entities .....	1030
application assertion .....	196
application object .....	26, 52
ARM diagrams .....	1331
mapping specification .....	720
combined_drill_and_reamer	
application object .....	22, 53
ARM diagrams .....	1314
mapping specification .....	587
combined_drill_and_tap	
application object .....	22, 53
ARM diagrams .....	1314
mapping specification .....	587
common_datum	
AIM diagrams .....	1389
AIM EXPRESS listing entities .....	1030
application assertion .....	196
application object .....	26, 53
ARM diagrams .....	1332
mapping specification .....	720
comparison_equal	
AIM diagrams .....	1398
AIM EXPRESS listing entities .....	1030
application object .....	15, 54
ARM diagrams .....	1334
mapping specification .....	422
comparison_expression	

AIM diagrams	1398
AIM EXPRESS listing entities	1030
application object	15, 54
ARM diagrams	1334
mapping specification	422
comparison_greater	
AIM diagrams	1398
AIM EXPRESS listing entities	1031
application object	15, 54
ARM diagrams	1334
mapping specification	423
comparison_greater_equal	
AIM diagrams	1398
AIM EXPRESS listing entities	1031
application object	15, 55
ARM diagrams	1334
mapping specification	423
comparison_less	
AIM diagrams	1398
AIM EXPRESS listing entities	1031
application object	15, 55
ARM diagrams	1334
mapping specification	423
comparison_less_equal	
AIM diagrams	1398
AIM EXPRESS listing entities	1031
application object	15, 55
ARM diagrams	1334
mapping specification	423
comparison_not_equal	
AIM diagrams	1398
AIM EXPRESS listing entities	1031
application object	15, 55
ARM diagrams	1334
mapping specification	424
compatible_dimension	
AIM EXPRESS listing rules	1215
complete_circular_path	
application object	11, 55
ARM diagrams	1329
mapping specification	268
complex_entity_instance	6
composite_curve	
AIM diagrams	1380
AIM EXPRESS listing entities	1031
composite_curve_on_surface	
AIM diagrams	1380
AIM EXPRESS listing entities	1031
composite_curve_segment	

AIM diagrams	1380
AIM EXPRESS listing entities	1031
composite_hole	
AIM diagrams	1387
AIM EXPRESS listing entities	1032
composite_shape_aspect	
AIM diagrams	1389
AIM EXPRESS listing entities	1032
compound_feature	
AIM diagrams	1387
AIM EXPRESS listing entities	1032
application object	11, 56
ARM diagrams	1319
mapping specification	269
compound_feature_select	
ARM diagrams	1319
compound_item_definition	
AIM diagrams	1368
AIM EXPRESS listing types	997
compound_representation_item	
AIM diagrams	1368
AIM EXPRESS listing entities	1034
computerized numerical control (CNC)	5
concentricity_tolerance	
AIM diagrams	1390
AIM EXPRESS listing entities	1034
application assertion	196
application object	27, 57
ARM diagrams	1331
mapping specification	721
concurrent_action_method	
AIM diagrams	1350
AIM EXPRESS listing entities	1034
conditional_reverse	
AIM EXPRESS listing functions	1223
conformance testing	5
conic	
AIM diagrams	1379
AIM EXPRESS listing entities	1034
conical_hole_bottom	
application object	11, 57
ARM diagrams	1322
mapping specification	270
conical_surface	
AIM diagrams	1376
AIM EXPRESS listing entities	1034
connect_direct	
application object	18, 58
ARM diagrams	1302

mapping specification .....	484
connect_secplane	
application object .....	18, 58
ARM diagrams .....	1302
mapping specification .....	484
connected_edge_set	
AIM diagrams .....	1385
AIM EXPRESS listing entities .....	1034
connected_face_set	
AIM diagrams .....	1384
AIM EXPRESS listing entities .....	1034
connector	
application object .....	18, 58
ARM diagrams .....	1302
mapping specification .....	485
const_cutting_speed	
application object .....	24, 58
ARM diagrams .....	1307
mapping specification .....	649
const_spindle_speed	
application object .....	24, 59
ARM diagrams .....	1307
mapping specification .....	650
constraints_composite_curve_on_surface	
AIM EXPRESS listing functions .....	1224
constraints_geometry_shell_based_surface_model	
AIM EXPRESS listing functions .....	1224
constraints_geometry_shell_based_wireframe_model	
AIM EXPRESS listing functions .....	1224
constraints_param_b_spline	
AIM EXPRESS listing functions .....	1225
constraints_rectangular_composite_surface	
AIM EXPRESS listing functions .....	1225
contact_type	
ARM diagrams .....	1303
context_dependent_measure	
AIM diagrams .....	1394
AIM EXPRESS listing types .....	998
context_dependent_shape_representation	
AIM diagrams .....	1368
AIM EXPRESS listing entities .....	1034
context_dependent_unit	
AIM diagrams .....	1396
AIM EXPRESS listing entities .....	1035
contour_bidirectional	
application object .....	20, 59
ARM diagrams .....	1309
mapping specification .....	519
contour_parallel	

application object	20, 59
ARM diagrams	1309
mapping specification	522
contour_spiral	
application object	20, 59
ARM diagrams	1309
mapping specification	524
contour_turning	
application object	24, 60
ARM diagrams	1311
mapping specification	651
contouring	
application object	24, 60
ARM diagrams	1306
mapping specification	655
contouring_finish	
application object	24, 60
ARM diagrams	1306
mapping specification	656
contouring_rough	
application object	24, 60
ARM diagrams	1306
mapping specification	656
contouring_turning_operation	
AIM diagrams	1348
AIM EXPRESS listing entities	1035
AIM EXPRESS short listing entities	819
conversion_based_unit	
AIM diagrams	1396
AIM EXPRESS listing entities	1035
coolant_select	
ARM diagrams	1308
coordinated_universal_time_offset	
AIM diagrams	1402
AIM EXPRESS listing entities	1035
corner_transition	
application object	26, 61
ARM diagrams	1317
mapping specification	689
corner_transition_select	
ARM diagrams	1317
count_measure	
AIM diagrams	1394
AIM EXPRESS listing types	998
counter_sinking	
application object	20, 61
ARM diagrams	1305
mapping specification	526
counterbore	



application object .....	22, 61
ARM diagrams .....	1315
mapping specification .....	588
counterbore_hole	
application object .....	11, 61
ARM diagrams .....	1319
mapping specification .....	273
countersink	
application object .....	22, 62
ARM diagrams .....	1315
mapping specification .....	588
countersunk_hole	
application object .....	11, 62
ARM diagrams .....	1319
mapping specification .....	274
cross_product	
AIM EXPRESS listing functions .....	1226
curve	
AIM diagrams .....	1378
AIM EXPRESS listing entities .....	1035
ARM diagrams .....	1343
curve_bounded_surface	
AIM diagrams .....	1374
AIM EXPRESS listing entities .....	1035
curve_on_surface	
AIM diagrams .....	1380
AIM EXPRESS listing types .....	998
curve_replica	
AIM diagrams .....	1378
AIM EXPRESS listing entities .....	1036
curve_weights_positive	
AIM EXPRESS listing functions .....	1227
curve_with_normal_vector	
application object .....	18, 62
ARM diagrams .....	1303
mapping specification .....	486
curve_with_surface_normal	
ARM diagrams .....	1303
curved_distance_dimension	
application assertion .....	196
application object .....	27, 63
ARM diagrams .....	1330
mapping specification .....	721
curved_size_dimension	
application object .....	27, 63
ARM diagrams .....	1330
mapping specification .....	721
cutmode_type	
ARM diagrams .....	1309

cutter_contact_trajectory	
application object	18, 63
ARM diagrams	1303
mapping specification	487
cutter_location_trajectory	
application object	18, 65
ARM diagrams	1303
mapping specification	491
cutting tools for milling UoF	7, 22
cutting tools for turning UoF	25
cutting_component	
application object	22, 66
ARM diagrams	1314
mapping specification	590
cutting_edge_properties	
application object	26, 67
ARM diagrams	1317
mapping specification	690
cutting_in	
application object	25, 67
ARM diagrams	1306
mapping specification	656
cylindrical_shape_representation	
AIM diagrams	1365
AIM EXPRESS listing entities	1036
AIM EXPRESS short listing entities	819
cylindrical_surface	
AIM diagrams	1373
AIM EXPRESS listing entities	1036
cylindricity_tolerance	
AIM diagrams	1390
AIM EXPRESS listing entities	1036
application object	27, 67
ARM diagrams	1331
mapping specification	721
data_environment	
AIM diagrams	1361
AIM EXPRESS listing entities	1036
date	
AIM diagrams	1402
AIM EXPRESS listing entities	1036
ARM diagrams	1342
date_and_time	
AIM diagrams	1402
AIM EXPRESS listing entities	1037
ARM diagrams	1342
date_and_time_assignment	
AIM diagrams	1403
AIM EXPRESS listing entities	1037

date_and_time_item	
AIM diagrams	1403
AIM EXPRESS listing types	998
AIM EXPRESS short listing types	807
date_assignment	
AIM diagrams	1403
AIM EXPRESS listing entities	1037
date_item	
AIM diagrams	1403
AIM EXPRESS listing types	998
AIM EXPRESS short listing types	808
date_role	
AIM diagrams	1403
AIM EXPRESS listing entities	1037
date_time_role	
AIM diagrams	1403
AIM EXPRESS listing entities	1037
date_time_select	
AIM diagrams	1402
AIM EXPRESS listing types	998
datum	5
AIM diagrams	1389
AIM EXPRESS listing entities	1037
application assertion	196
application object	27, 67
ARM diagrams	1332
mapping specification	721
datum_defined_by_derived_shape	
application object	27
ARM diagrams	1332
mapping specification	722
datum_defined_by_feature	
application object	27
ARM diagrams	1332
mapping specification	722
datum_defined_by_targets	
application assertion	196
application object	27, 68
ARM diagrams	1332
mapping specification	722
datum_feature	
AIM diagrams	1389
AIM EXPRESS listing entities	1037
datum_reference	
AIM diagrams	1389
AIM EXPRESS listing entities	1038
application assertion	195, 196, 199, 200, 201, 202
application object	27, 69
ARM diagrams	1331

mapping specification .....	722
datum_target	
AIM diagrams .....	1389
AIM EXPRESS listing entities .....	1038
application assertion .....	196
application object .....	27, 69
ARM diagrams .....	1332
mapping specification .....	723
datum_target_set	
mapping specification .....	723
day_in_month_number	
AIM diagrams .....	1402
AIM EXPRESS listing types .....	998
day_in_week_number	
AIM diagrams .....	1402
AIM EXPRESS listing types .....	998
day_in_year_number	
AIM diagrams .....	1402
AIM EXPRESS listing types .....	998
defined_thread	
application object .....	11, 70
ARM diagrams .....	1325
mapping specification .....	275
definitional_representation	
AIM diagrams .....	1364
AIM EXPRESS listing entities .....	1038
degenerate_pcurve	
AIM diagrams .....	1371
AIM EXPRESS listing entities .....	1038
degenerate_toroidal_surface	
AIM diagrams .....	1376
AIM EXPRESS listing entities .....	1038
dependent_instantiable_approval_status	
AIM EXPRESS listing rules .....	1215
AIM EXPRESS short listing rules .....	932
dependent_instantiable_derived_unit	
AIM EXPRESS listing rules .....	1215
AIM EXPRESS short listing rules .....	933
dependent_instantiable_named_unit	
AIM EXPRESS listing rules .....	1216
AIM EXPRESS short listing rules .....	933
derive_dimensional_exponents	
AIM EXPRESS listing functions .....	1227
derived_geometry	
application object .....	70
ARM diagrams .....	1332
derived_property_select	
AIM diagrams .....	1363
AIM EXPRESS listing types .....	998

derived_shape_aspect	
AIM diagrams	1388
AIM EXPRESS listing entities	1039
derived_unit	
AIM diagrams	1396
AIM EXPRESS listing entities	1039
AIM EXPRESS short listing imported entity modifications	926
derived_unit_element	
AIM diagrams	1396
AIM EXPRESS listing entities	1039
description_attribute	
AIM diagrams	1410
AIM EXPRESS listing entities	1039
description_attribute_select	
AIM diagrams	1410
AIM EXPRESS listing types	999
descriptive_measure	
AIM diagrams	1394
AIM EXPRESS listing types	999
descriptive_parameter	
application object	9, 71
ARM diagrams	1336
mapping specification	220
descriptive_representation_item	
AIM diagrams	1367
AIM EXPRESS listing entities	1039
diagonal_knurl	
application object	23, 71
ARM diagrams	1326
mapping specification	625
diameter_size_dimension	
application object	27, 71
ARM diagrams	1330
mapping specification	724
diameter_taper	
application object	11, 71
ARM diagrams	1322
mapping specification	277
diamond_knurl	
application object	24, 72
ARM diagrams	1326
mapping specification	626
dimension	5
dimension_count	
AIM diagrams	1370
AIM EXPRESS listing types	999
dimension_related_tolerance_zone_element	
AIM diagrams	1392
AIM EXPRESS listing entities	1039

dimension_value_select	
ARM diagrams	1330
dimensional_characteristic	
AIM diagrams	1391
AIM EXPRESS listing types	999
dimensional_characteristic_representation	
AIM diagrams	1391
AIM EXPRESS listing entities	1039
dimensional_exponents	
AIM diagrams	1396
AIM EXPRESS listing entities	1040
dimensional_location	
AIM diagrams	1388
AIM EXPRESS listing entities	1040
dimensional_location_with_path	
AIM diagrams	1388
AIM EXPRESS listing entities	1040
dimensional_size	
AIM diagrams	1391
AIM EXPRESS listing entities	1040
dimensional_size_with_path	
AIM diagrams	1391
AIM EXPRESS listing entities	1040
dimensions_for_si_unit	
AIM EXPRESS listing functions	1228
directed_dimensional_location	
AIM diagrams	1388
AIM EXPRESS listing entities	1040
AIM EXPRESS short listing entities	820
direction	
AIM diagrams	1370
AIM EXPRESS listing entities	1040
ARM diagrams	1343
direction_shape_representation	
AIM diagrams	1365
AIM EXPRESS listing entities	1040
display_message	
application object	15, 72
ARM diagrams	1298
mapping specification	424
document	
AIM diagrams	1404
AIM EXPRESS listing entities	1041
document_file	
AIM diagrams	1387
AIM EXPRESS listing entities	1041
AIM EXPRESS short listing entities	821
document_reference	
AIM diagrams	1405

AIM EXPRESS listing entities .....	1041
document_reference_item	
AIM diagrams .....	1405
AIM EXPRESS listing types .....	999
AIM EXPRESS short listing types .....	808
document_representation_type	
AIM diagrams .....	1404
AIM EXPRESS listing entities .....	1041
document_type	
AIM diagrams .....	1404
AIM EXPRESS listing entities .....	1041
document_usage_constraint	
AIM diagrams .....	1405
AIM EXPRESS listing entities .....	1041
document_usage_constraint_assignment	
AIM diagrams .....	1405
AIM EXPRESS listing entities .....	1042
document_usage_role	
AIM diagrams .....	1405
AIM EXPRESS listing entities .....	1042
document_with_class	
AIM diagrams .....	1404
AIM EXPRESS listing entities .....	1042
dot_product	
AIM EXPRESS listing functions .....	1230
dovetail_mill	
application object .....	22, 72
ARM diagrams .....	1315
mapping specification .....	592
drilling	
application object .....	20, 73
ARM diagrams .....	1305
mapping specification .....	526
drilling_cutting_tool	
application object .....	22, 73
ARM diagrams .....	1315
mapping specification .....	593
drilling_operation	
AIM diagrams .....	1348
AIM EXPRESS listing entities .....	1042
AIM EXPRESS short listing entities .....	822
application object .....	20, 73
ARM diagrams .....	1305
mapping specification .....	526
drilling_type_operation	
AIM diagrams .....	1348
AIM EXPRESS listing entities .....	1042
AIM EXPRESS short listing entities .....	823
application object .....	20, 73

ARM diagrams	1305
mapping specification	527
drilling_type_strategy	
AIM diagrams	1347
AIM EXPRESS listing entities	1043
AIM EXPRESS short listing entities	824
application object	20, 74
ARM diagrams	1310
mapping specification	531
dwell_revolution	
ARM diagrams	1306
dwell_select	
ARM diagrams	1306
edge	
AIM diagrams	1383
AIM EXPRESS listing entities	1044
edge_based_wireframe_model	
AIM diagrams	1385
AIM EXPRESS listing entities	1044
edge_based_wireframe_shape_representation	
AIM diagrams	1365
AIM EXPRESS listing entities	1044
ARM diagrams	1344
edge_curve	
AIM diagrams	1383
AIM EXPRESS listing entities	1045
ARM diagrams	1343
edge_loop	
AIM diagrams	1383
AIM EXPRESS listing entities	1045
edge_reversed	
AIM EXPRESS listing functions	1230
edge_round	
AIM diagrams	1386
AIM EXPRESS listing entities	1045
AIM EXPRESS short listing imported entity modifications	926
application object	11, 74
ARM diagrams	1320
mapping specification	278
edge_round_requires_faces_or_features	
AIM EXPRESS listing rules	1216
AIM EXPRESS short listing rules	934
elementary_surface	
AIM diagrams	1373
AIM EXPRESS listing entities	1047
ARM diagrams	1343
ellipse	
AIM diagrams	1379
AIM EXPRESS listing entities	1047



endmill	
application object	22, 75
ARM diagrams	1315
mapping specification	594
environment	
AIM diagrams	1397
AIM EXPRESS listing entities	1047
evaluated_degenerate_pcurve	
AIM diagrams	1371
AIM EXPRESS listing entities	1047
exchange_pallet	
application object	20, 75
ARM diagrams	1298
mapping specification	536
executable	6
application assertion	198, 200
application object	15, 76
ARM diagrams	1298
mapping specification	424
executable UoF	7, 15
expanded_uncertainty	
AIM diagrams	1395
AIM EXPRESS listing entities	1047
explicit_strategy	
application object	20, 76
ARM diagrams	1309
mapping specification	536
explicit_turning_strategy	
application object	25, 76
ARM diagrams	1311
mapping specification	657
expression	
AIM diagrams	1398
AIM EXPRESS listing entities	1047
expression_representation_item	
AIM diagrams	1367
AIM EXPRESS listing entities	1048
AIM EXPRESS short listing entities	826
extended_nc_function	
application object	17, 76
ARM diagrams	1298
mapping specification	425
extension	
AIM diagrams	1388
AIM EXPRESS listing entities	1048
external_identification_assignment	
AIM diagrams	1363
AIM EXPRESS listing entities	1048
external_identification_item	

AIM diagrams	1363
AIM EXPRESS listing types	999
AIM EXPRESS short listing types	808
external_source	
AIM diagrams	1362
AIM EXPRESS listing entities	1048
externally_defined_class	
AIM diagrams	1362
AIM EXPRESS listing entities	1048
AIM EXPRESS short listing entities	826
externally_defined_dimension_definition	
AIM diagrams	1391
AIM EXPRESS listing entities	1048
AIM EXPRESS short listing entities	827
externally_defined_feature_definition	
AIM diagrams	1387
AIM EXPRESS listing entities	1049
externally_defined_general_property	
AIM diagrams	1362
AIM EXPRESS listing entities	1055
AIM EXPRESS short listing entities	828
externally_defined_item	
AIM diagrams	1362
AIM EXPRESS listing entities	1055
externally_defined_item_relationship	
AIM diagrams	1362
AIM EXPRESS listing entities	1055
externally_defined_representation	
application assertion	196, 202
application object	29, 77
ARM diagrams	1313
mapping specification	751
externally_defined_representation_with_parameters	
AIM diagrams	1364
AIM EXPRESS listing entities	1056
AIM EXPRESS short listing entities	829
externally_defined_size_dimension	
application assertion	197
application object	27, 77
ARM diagrams	1330
mapping specification	724
face	
AIM diagrams	1382
AIM EXPRESS listing entities	1056
ARM diagrams	1343
face_based_surface_model	
AIM diagrams	1384
AIM EXPRESS listing entities	1056
face_bound	

AIM diagrams . . . . .	1382
AIM EXPRESS listing entities . . . . .	1056
face_bound_reversed	
AIM EXPRESS listing functions . . . . .	1231
face_outer_bound	
AIM diagrams . . . . .	1382
AIM EXPRESS listing entities . . . . .	1056
face_reversed	
AIM EXPRESS listing functions . . . . .	1231
face_shape_representation	
AIM diagrams . . . . .	1365
AIM EXPRESS listing entities . . . . .	1056
face_surface	
AIM diagrams . . . . .	1382
AIM EXPRESS listing entities . . . . .	1056
facemill	
application object . . . . .	22, 78
ARM diagrams . . . . .	1315
mapping specification . . . . .	595
faceted_brep	
AIM diagrams . . . . .	1384
AIM EXPRESS listing entities . . . . .	1057
faceted_brep_shape_representation	
AIM diagrams . . . . .	1365
AIM EXPRESS listing entities . . . . .	1057
ARM diagrams . . . . .	1344
facing	
application object . . . . .	25, 78
ARM diagrams . . . . .	1306
mapping specification . . . . .	657
facing_finish	
application object . . . . .	25, 79
ARM diagrams . . . . .	1306
mapping specification . . . . .	657
facing_rough	
application object . . . . .	25, 79
ARM diagrams . . . . .	1306
mapping specification . . . . .	658
facing_turning_operation	
AIM diagrams . . . . .	1348
AIM EXPRESS listing entities . . . . .	1057
AIM EXPRESS short listing entities . . . . .	829
feature_component_definition	
AIM diagrams . . . . .	1387
AIM EXPRESS listing entities . . . . .	1058
feature_component_relationship	
AIM diagrams . . . . .	1388
AIM EXPRESS listing entities . . . . .	1058
feature_definition	

AIM diagrams . . . . .	1387
AIM EXPRESS listing entities . . . . .	1058
feature_optional_machining_property_process	
AIM EXPRESS listing rules . . . . .	1216
AIM EXPRESS short listing rules . . . . .	936
feature_pattern	
AIM diagrams . . . . .	1387
AIM EXPRESS listing entities . . . . .	1059
feed_per_rev_type	
ARM diagrams . . . . .	1311
feed_select	
ARM diagrams . . . . .	1311
feedstop	
application object . . . . .	18, 79
ARM diagrams . . . . .	1302
mapping specification . . . . .	494
fillet	
AIM diagrams . . . . .	1386
AIM EXPRESS listing entities . . . . .	1060
finishing . . . . .	6
first_proj_axis	
AIM EXPRESS listing functions . . . . .	1231
five_axes_const_tilt_yaw	
application object . . . . .	20, 79
ARM diagrams . . . . .	1301
mapping specification . . . . .	536
five_axes_var_tilt_yaw	
application object . . . . .	20, 80
ARM diagrams . . . . .	1301
mapping specification . . . . .	537
flat_face	
AIM diagrams . . . . .	1387
AIM EXPRESS listing entities . . . . .	1061
flat_hole_bottom	
application object . . . . .	11, 80
ARM diagrams . . . . .	1322
mapping specification . . . . .	284
flat_slot_end_type	
application object . . . . .	11, 80
ARM diagrams . . . . .	1324
mapping specification . . . . .	284
flat_with_radius_hole_bottom	
application object . . . . .	11, 80
ARM diagrams . . . . .	1322
mapping specification . . . . .	286
flatness_tolerance	
AIM diagrams . . . . .	1390
AIM EXPRESS listing entities . . . . .	1063
application object . . . . .	27, 81

ARM diagrams	1331
mapping specification	725
founded_item	
AIM diagrams	1380
AIM EXPRESS listing entities	1063
founded_item_select	
AIM diagrams	1380
AIM EXPRESS listing types	999
freeform_machining	6
freeform_finish_milling	
application object	22, 81
ARM diagrams	1304
mapping specification	537
freeform_milling_operation	
AIM diagrams	1348
AIM EXPRESS listing entities	1063
AIM EXPRESS short listing entities	830
freeform_milling_strategy	
AIM diagrams	1347
AIM EXPRESS listing entities	1063
AIM EXPRESS short listing entities	831
freeform_milling_tolerance_representation	
AIM diagrams	1364
AIM EXPRESS listing entities	1064
AIM EXPRESS short listing entities	833
freeform_operation	
application object	20, 81
ARM diagrams	1304
mapping specification	537
freeform_rough_milling	
application object	22, 81
ARM diagrams	1304
mapping specification	538
freeform_strategy	
application object	20, 82
ARM diagrams	1310
mapping specification	538
functionally_defined_transformation	
AIM diagrams	1369
AIM EXPRESS listing entities	1064
gbsf_check_curve	
AIM EXPRESS listing functions	1232
gbsf_check_point	
AIM EXPRESS listing functions	1233
gbsf_check_surface	
AIM EXPRESS listing functions	1234
gear	
AIM diagrams	1387
AIM EXPRESS listing entities	1064

general_closed_profile	
application object	11, 82
ARM diagrams	1327
mapping specification	287
general_outside_profile	
application object	11, 83
ARM diagrams	1324
mapping specification	289
general_path	
application object	11, 83
ARM diagrams	1329
mapping specification	290
general_pattern	
application object	11, 83
ARM diagrams	1321
mapping specification	291
general_pocket_bottom_condition	
application object	11, 84
ARM diagrams	1323
mapping specification	292
general_profile	
application object	11, 84
ARM diagrams	1327
mapping specification	293
general_profile_floor	
application object	11, 84
ARM diagrams	1324
mapping specification	294
general_property	
AIM diagrams	1362
AIM EXPRESS listing entities	1069
application assertion	197
application object	10, 85
ARM diagrams	1335
mapping specification	220
general_property_association	
AIM diagrams	1363
AIM EXPRESS listing entities	1069
general_property_item	
ARM diagrams	1335
general_revolution	
application object	24, 86
ARM diagrams	1326
mapping specification	627
general_shape_profile	
application object	11, 86
ARM diagrams	1324
mapping specification	295
general_turning_tool	

application object .....	26, 86
ARM diagrams .....	1316
mapping specification .....	695
generic_expression	
AIM diagrams .....	1397
AIM EXPRESS listing entities .....	1069
generic_literal	
AIM diagrams .....	1397
AIM EXPRESS listing entities .....	1069
generic_variable	
AIM diagrams .....	1397
AIM EXPRESS listing entities .....	1069
geometric dimensioning and tolerancing UoF .....	7, 26
geometric_alignment	
AIM diagrams .....	1388
AIM EXPRESS listing entities .....	1069
geometric_curve_set	
AIM diagrams .....	1376
AIM EXPRESS listing entities .....	1069
geometric_dimension	
application assertion .....	197
application object .....	27, 86
ARM diagrams .....	1330
mapping specification .....	725
geometric_intersection	
AIM diagrams .....	1388
AIM EXPRESS listing entities .....	1070
geometric_representation_context	
AIM diagrams .....	1366
AIM EXPRESS listing entities .....	1070
geometric_representation_item	
AIM diagrams .....	1370
AIM EXPRESS listing entities .....	1070
geometric_set	
AIM diagrams .....	1376
AIM EXPRESS listing entities .....	1070
geometric_set_select	
AIM diagrams .....	1376
AIM EXPRESS listing types .....	999
geometric_tolerance	
AIM diagrams .....	1390
AIM EXPRESS listing entities .....	1070
application assertion .....	197, 202
application object .....	27, 87
ARM diagrams .....	1331
mapping specification .....	726
geometric_tolerance_relationship	
AIM diagrams .....	1390
AIM EXPRESS listing entities .....	1070

application assertion .....	197
application object .....	27, 88
ARM diagrams .....	1333
mapping specification .....	727
geometric_tolerance_with_datum_reference	
AIM diagrams .....	1390
AIM EXPRESS listing entities .....	1070
geometric_tolerance_with_defined_unit	
AIM diagrams .....	1390
AIM EXPRESS listing entities .....	1071
geometrically_bounded_surface_shape_representation	
AIM diagrams .....	1365
AIM EXPRESS listing entities .....	1071
ARM diagrams .....	1344
geometrically_bounded_wireframe_shape_representation	
AIM diagrams .....	1365
AIM EXPRESS listing entities .....	1071
ARM diagrams .....	1344
get_action_property	
AIM EXPRESS listing functions .....	1235
AIM EXPRESS short listing functions .....	939
get_basis_surface	
AIM EXPRESS listing functions .....	1235
get_count_of_relating_amr	
AIM EXPRESS listing functions .....	1235
AIM EXPRESS short listing functions .....	940
get_count_of_relating_amr_with_name	
AIM EXPRESS listing functions .....	1236
AIM EXPRESS short listing functions .....	940
get_description_value	
AIM EXPRESS listing functions .....	1236
get_id_value	
AIM EXPRESS listing functions .....	1236
get_name_value	
AIM EXPRESS listing functions .....	1236
get_property_definition_representations	
AIM EXPRESS listing functions .....	1237
get_relating_amr	
AIM EXPRESS listing functions .....	1237
AIM EXPRESS short listing functions .....	941
get_resource_property	
AIM EXPRESS listing functions .....	1237
AIM EXPRESS short listing functions .....	941
get_role	
AIM EXPRESS listing functions .....	1237
get_tool_body_item	
AIM EXPRESS listing functions .....	1238
AIM EXPRESS short listing functions .....	942
global_uncertainty_assigned_context	



AIM diagrams	1366
AIM EXPRESS listing entities	1072
global_unit_assigned_context	
AIM diagrams	1366
AIM EXPRESS listing entities	1072
groove	
application object	24, 89
ARM diagrams	1326
mapping specification	628
grooving	
application object	25, 90
ARM diagrams	1306
mapping specification	658
grooving_finish	
application object	25, 90
ARM diagrams	1306
mapping specification	659
grooving_rough	
application object	25, 90
ARM diagrams	1306
mapping specification	659
grooving_strategy	
application object	25, 90
ARM diagrams	1311
mapping specification	659
grooving_tool	
application object	26, 91
ARM diagrams	1316
mapping specification	695
grooving_turning_operation	
AIM diagrams	1348
AIM EXPRESS listing entities	1072
AIM EXPRESS short listing entities	833
group	
AIM diagrams	1362
AIM EXPRESS listing entities	1073
hand_of_cut_type	
ARM diagrams	1314
hand_of_tool_type	
ARM diagrams	1316
hardness	
application assertion	199
application object	10, 91
ARM diagrams	1335
mapping specification	221
height_size_dimension	
application assertion	198
application object	27, 92
ARM diagrams	1330

mapping specification .....	728
hole_bottom	
AIM diagrams .....	1386
AIM EXPRESS listing entities .....	1073
hole_bottom_condition	
application object .....	12, 92
ARM diagrams .....	1322
mapping specification .....	296
hour_in_day	
AIM diagrams .....	1402
AIM EXPRESS listing types .....	999
hyperbola	
AIM diagrams .....	1379
AIM EXPRESS listing entities .....	1076
id_attribute	
AIM diagrams .....	1409
AIM EXPRESS listing entities .....	1076
id_attribute_select	
AIM diagrams .....	1409
AIM EXPRESS listing types .....	1000
identification_assignment	
AIM diagrams .....	1363
AIM EXPRESS listing entities .....	1076
identification_item	
AIM diagrams .....	1363
AIM EXPRESS listing types .....	1000
AIM EXPRESS short listing types .....	809
identification_role	
AIM diagrams .....	1363
AIM EXPRESS listing entities .....	1076
identifier	
AIM diagrams .....	1411
AIM EXPRESS listing types .....	1000
ARM diagrams .....	1342
if_statement	
application object .....	15, 92
ARM diagrams .....	1298
mapping specification .....	425
implementation method .....	5
in_process_geometry	
application object .....	15, 93
ARM diagrams .....	1299
mapping specification .....	427
index_pallet	
application object .....	20, 94
ARM diagrams .....	1298
mapping specification .....	541
index_table	
application object .....	20, 94

ARM diagrams .....	1298
mapping specification .....	542
instanced_feature	
AIM diagrams .....	1386
AIM EXPRESS listing entities .....	1076
int_literal	
AIM diagrams .....	1397
AIM EXPRESS listing entities .....	1076
int_numeric_variable	
AIM diagrams .....	1397
AIM EXPRESS listing entities .....	1077
integrated_resource .....	5
intersection_curve	
AIM diagrams .....	1379
AIM EXPRESS listing entities .....	1077
is_acyclic	
AIM EXPRESS listing functions .....	1238
is_int_expr	
AIM EXPRESS listing functions .....	1238
is_SQL_mappable	
AIM EXPRESS listing functions .....	1239
ISO 14649-11 .....	19
ISO 14649-111 .....	22
ISO 14649-12 .....	23
ISO 14649-121 .....	25
item_defined_transformation	
AIM diagrams .....	1369
AIM EXPRESS listing entities .....	1077
item_in_context	
AIM EXPRESS listing functions .....	1239
knot_type	
AIM diagrams .....	1381
AIM EXPRESS listing types .....	1000
known_source	
AIM diagrams .....	1362
AIM EXPRESS listing entities .....	1077
AIM EXPRESS short listing entities .....	834
knurl	
application object .....	24, 94
ARM diagrams .....	1326
mapping specification .....	629
knurl_pattern_type	
ARM diagrams .....	1316
knurling	
application object .....	25, 94
ARM diagrams .....	1306
mapping specification .....	661
knurling_tool	
application object .....	26, 95

ARM diagrams	1316
mapping specification	699
knurling_turning_operation	
AIM diagrams	1348
AIM EXPRESS listing entities	1077
AIM EXPRESS short listing entities	835
label	
AIM diagrams	1411
AIM EXPRESS listing types	1000
ARM diagrams	1342
last_modified_timestamp	
application assertion	198
application object	29, 95
ARM diagrams	1338
mapping specification	762
last_modified_timestamp_item	
ARM diagrams	1338
leading_line_strategy	
application object	20, 95
ARM diagrams	1310
mapping specification	543
leap_year	
AIM EXPRESS listing functions	1240
left_or_right	
ARM diagrams	1309
length_measure	
AIM diagrams	1394
AIM EXPRESS listing types	1000
application object	8, 96
ARM diagrams	1341
mapping specification	207
length_measure_with_unit	
AIM diagrams	1393
AIM EXPRESS listing entities	1077
length_size_dimension	
application assertion	198
application object	27, 96
ARM diagrams	1330
mapping specification	728
length_unit	
AIM diagrams	1396
AIM EXPRESS listing entities	1077
library reference UoF	8, 28
library_part_assignment	
application assertion	196, 198
application object	29, 96
ARM diagrams	1313
mapping specification	752
library_property_value	

application assertion .....	198, 199
application object .....	29, 97
ARM diagrams .....	1313
mapping specification .....	753
limit_condition	
AIM diagrams .....	1389
AIM EXPRESS listing types .....	1000
limit_qualifier	
application assertion .....	202
application object .....	8, 97
ARM diagrams .....	1341
mapping specification .....	209
limitation_select	
ARM diagrams .....	1341
limits_and_fits	
AIM diagrams .....	1391
AIM EXPRESS listing entities .....	1077
application assertion .....	202
application object .....	8, 98
ARM diagrams .....	1341
mapping specification .....	207
line	
AIM diagrams .....	1378
AIM EXPRESS listing entities .....	1078
line_profile_tolerance	
AIM diagrams .....	1390
AIM EXPRESS listing entities .....	1078
application assertion .....	199
application object .....	27, 99
ARM diagrams .....	1331
mapping specification .....	729
linear_distance_dimension	
application object .....	27, 100
ARM diagrams .....	1330
mapping specification .....	730
linear_path	
application assertion .....	195, 200
application object .....	12, 100
ARM diagrams .....	1329
mapping specification .....	296
linear_profile	
AIM diagrams .....	1386
AIM EXPRESS listing entities .....	1078
application object .....	12, 100
ARM diagrams .....	1327
mapping specification .....	298
list_face_loops	
AIM EXPRESS listing functions .....	1240
list_of_reversible_topology_item	

AIM diagrams	1377
AIM EXPRESS listing types	1000
list_of_topology_reversed	
AIM EXPRESS listing functions	1240
list_representation_item	
AIM diagrams	1368
AIM EXPRESS listing types	1000
list_to_array	
AIM EXPRESS listing functions	1240
list_to_set	
AIM EXPRESS listing functions	1241
literal_number	
AIM diagrams	1397
AIM EXPRESS listing entities	1079
load_tool	
application object	20, 101
ARM diagrams	1298
mapping specification	544
local_time	
AIM diagrams	1402
AIM EXPRESS listing entities	1079
location_dimension	
application object	27, 101
ARM diagrams	1330
mapping specification	731
location_shape_representation	
AIM diagrams	1365
AIM EXPRESS listing entities	1079
loop	
AIM diagrams	1383
AIM EXPRESS listing entities	1079
loop_slot_end_type	
application object	12, 102
ARM diagrams	1324
mapping specification	299
machine_axis_constraint	
application assertion	199
application object	22, 102
ARM diagrams	1308
mapping specification	545
machine_axis_travel	
application assertion	199
application object	17, 103
ARM diagrams	1339
mapping specification	429
machine_functions	
application object	17, 103
ARM diagrams	1308
mapping specification	473

machine_parameters	
application assertion	199, 204
application object	17, 103
ARM diagrams	1339
mapping specification	430
machined_surface	
application object	12, 106
ARM diagrams	1336
mapping specification	299
machining_operation	6
machining_adaptive_control_relationship	
AIM diagrams	1349
AIM EXPRESS listing entities	1079
AIM EXPRESS short listing entities	835
machining_approach_retract_strategy	
AIM diagrams	1347
AIM EXPRESS listing entities	1079
AIM EXPRESS short listing entities	835
machining_cutting_component	
AIM diagrams	1387
AIM EXPRESS listing entities	1080
AIM EXPRESS short listing entities	837
machining_cutting_corner_representation	
AIM diagrams	1364
AIM EXPRESS listing entities	1081
AIM EXPRESS short listing entities	840
machining_dwell_time_representation	
AIM diagrams	1364
AIM EXPRESS listing entities	1082
AIM EXPRESS short listing entities	841
machining_execution_resource	
AIM diagrams	1352
AIM EXPRESS listing entities	1083
AIM EXPRESS short listing entities	842
machining_feature	
application object	12, 106
ARM diagrams	1322
mapping specification	300
machining_feature_process	
AIM diagrams	1347
AIM EXPRESS listing entities	1084
AIM EXPRESS short listing entities	846
machining_feature_relationship	
AIM diagrams	1349
AIM EXPRESS listing entities	1084
AIM EXPRESS short listing entities	846
machining_feature_sequence_relationship	
AIM diagrams	1349
AIM EXPRESS listing entities	1084

AIM EXPRESS short listing entities .....	846
machining_feed_speed_representation	
AIM diagrams .....	1364
AIM EXPRESS listing entities .....	1085
AIM EXPRESS short listing entities .....	847
machining_final_feature_relationship	
AIM diagrams .....	1349
AIM EXPRESS listing entities .....	1085
AIM EXPRESS short listing entities .....	848
machining_functions	
AIM diagrams .....	1347
AIM EXPRESS listing entities .....	1085
AIM EXPRESS short listing entities .....	849
machining_functions_relationship	
AIM diagrams .....	1349
AIM EXPRESS listing entities .....	1087
AIM EXPRESS short listing entities .....	853
machining_nc_function	
AIM diagrams .....	1347
AIM EXPRESS listing entities .....	1087
AIM EXPRESS short listing entities .....	853
machining_offset_vector_representation	
AIM diagrams .....	1364
AIM EXPRESS listing entities .....	1088
AIM EXPRESS short listing entities .....	855
machining_operation	
AIM diagrams .....	1347
AIM EXPRESS listing entities .....	1089
AIM EXPRESS short listing entities .....	856
application object .....	17, 107
ARM diagrams .....	1301
mapping specification .....	473
machining_operation_relationship	
AIM diagrams .....	1349
AIM EXPRESS listing entities .....	1089
AIM EXPRESS short listing entities .....	857
machining_operator_instruction	
AIM diagrams .....	1347
AIM EXPRESS listing entities .....	1089
AIM EXPRESS short listing entities .....	858
machining_operator_instruction_relationship	
AIM diagrams .....	1350
AIM EXPRESS listing entities .....	1090
AIM EXPRESS short listing entities .....	858
machining_process_body_relationship	
AIM diagrams .....	1349
AIM EXPRESS listing entities .....	1090
AIM EXPRESS short listing entities .....	858
machining_process_branch_relationship	



AIM diagrams .....	1349
AIM EXPRESS listing entities .....	1090
AIM EXPRESS short listing entities .....	859
machining_process_concurrent_relationship	
AIM diagrams .....	1350
AIM EXPRESS listing entities .....	1090
machining_process_executable	
AIM diagrams .....	1347
AIM EXPRESS listing entities .....	1090
AIM EXPRESS short listing entities .....	859
machining_process_model	
AIM diagrams .....	1347
AIM EXPRESS listing entities .....	1092
AIM EXPRESS short listing entities .....	863
machining_process_model_relationship	
AIM diagrams .....	1350
AIM EXPRESS listing entities .....	1092
AIM EXPRESS short listing entities .....	863
machining_process_sequence_relationship	
AIM diagrams .....	1350
AIM EXPRESS listing entities .....	1092
AIM EXPRESS short listing entities .....	863
machining_project	
AIM diagrams .....	1356
AIM EXPRESS listing entities .....	1092
AIM EXPRESS short listing entities .....	864
machining_project_workpiece_relationship	
AIM diagrams .....	1359
AIM EXPRESS listing entities .....	1093
AIM EXPRESS short listing entities .....	865
machining_rapid_movement	
AIM diagrams .....	1347
AIM EXPRESS listing entities .....	1093
AIM EXPRESS short listing entities .....	865
machining_setup	
AIM diagrams .....	1356
AIM EXPRESS listing entities .....	1093
AIM EXPRESS short listing entities .....	866
machining_setup_workpiece_relationship	
AIM diagrams .....	1359
AIM EXPRESS listing entities .....	1093
AIM EXPRESS short listing entities .....	866
machining_spindle_speed_representation	
AIM diagrams .....	1364
AIM EXPRESS listing entities .....	1093
AIM EXPRESS short listing entities .....	867
machining_strategy	
AIM diagrams .....	1347
AIM EXPRESS listing entities .....	1094

AIM EXPRESS short listing entities .....	868
machining_strategy_relationship	
AIM diagrams .....	1349
AIM EXPRESS listing entities .....	1094
AIM EXPRESS short listing entities .....	868
machining_technology	
AIM diagrams .....	1347
AIM EXPRESS listing entities .....	1094
AIM EXPRESS short listing entities .....	869
machining_technology_relationship	
AIM diagrams .....	1349
AIM EXPRESS listing entities .....	1096
AIM EXPRESS short listing entities .....	872
machining_tool	
AIM diagrams .....	1352
AIM EXPRESS listing entities .....	1096
AIM EXPRESS short listing entities .....	873
application assertion .....	199
application object .....	15, 107
ARM diagrams .....	1313
mapping specification .....	439
machining_tool_body_representation	
AIM diagrams .....	1364
AIM EXPRESS listing entities .....	1102
AIM EXPRESS short listing entities .....	888
machining_tool_direction_representation	
AIM diagrams .....	1364
AIM EXPRESS listing entities .....	1102
AIM EXPRESS short listing entities .....	888
machining_tool_usage	
AIM diagrams .....	1347
AIM EXPRESS listing entities .....	1103
AIM EXPRESS short listing entities .....	889
machining_toolpath	
AIM diagrams .....	1347
AIM EXPRESS listing entities .....	1103
AIM EXPRESS short listing entities .....	890
machining_toolpath_sequence_relationship	
AIM diagrams .....	1350
AIM EXPRESS listing entities .....	1106
AIM EXPRESS short listing entities .....	897
machining_toolpath_speed_profile_representation	
AIM diagrams .....	1364
AIM EXPRESS listing entities .....	1106
AIM EXPRESS short listing entities .....	897
machining_touch_probing	
AIM diagrams .....	1347
AIM EXPRESS listing entities .....	1107
AIM EXPRESS short listing entities .....	898

machining_workingstep	
AIM diagrams	1347
AIM EXPRESS listing entities	1108
AIM EXPRESS short listing entities	901
application assertion	199
application object	15, 108
ARM diagrams	1299
mapping specification	440
machining_workplan	
AIM diagrams	1347
AIM EXPRESS listing entities	1109
AIM EXPRESS short listing entities	903
make_array_of_array	
AIM EXPRESS listing functions	1241
make_from_usage_option	
AIM diagrams	1359
AIM EXPRESS listing entities	1110
management UoF	8, 29
manifold_solid_brep	
AIM diagrams	1384
AIM EXPRESS listing entities	1110
manifold_surface_shape_representation	
AIM diagrams	1365
AIM EXPRESS listing entities	1110
ARM diagrams	1344
manufacturing feature for turning UoF	7
manufacturing feature UoF	7, 10
manufacturing_feature	
application assertion	199
application object	9, 109
ARM diagrams	1319
mapping specification	222
mapped_item	
AIM diagrams	1367
AIM EXPRESS listing entities	1113
marking	
AIM diagrams	1387
AIM EXPRESS listing entities	1113
mass_measure	
AIM diagrams	1394
AIM EXPRESS listing types	1000
application object	9, 110
ARM diagrams	1341
mapping specification	209
mass_measure_with_unit	
AIM diagrams	1393
AIM EXPRESS listing entities	1115
mass_unit	
AIM diagrams	1396

AIM EXPRESS listing entities .....	1115
material	
application object .....	9, 110
ARM diagrams .....	1336
mapping specification .....	225
material_designation	
AIM diagrams .....	1361
AIM EXPRESS listing entities .....	1115
material_designation_characterization	
AIM diagrams .....	1361
AIM EXPRESS listing entities .....	1115
material_property	
AIM diagrams .....	1360
AIM EXPRESS listing entities .....	1115
application assertion .....	199
application object .....	10, 110
ARM diagrams .....	1335
mapping specification .....	226
material_property_representation	
AIM diagrams .....	1361
AIM EXPRESS listing entities .....	1115
measure UoF .....	7, 8
measure_qualification	
AIM diagrams .....	1395
AIM EXPRESS listing entities .....	1116
measure_representation_item	
AIM diagrams .....	1367
AIM EXPRESS listing entities .....	1116
measure_value	
AIM diagrams .....	1394
AIM EXPRESS listing types .....	1000
ARM diagrams .....	1342
measure_with_unit	
AIM diagrams .....	1393
AIM EXPRESS listing entities .....	1116
measurement_path	
application assertion .....	196, 197, 198, 201, 202
application object .....	27, 111
ARM diagrams .....	1330
mapping specification .....	732
milling_cutting_tool	
application object .....	22, 111
ARM diagrams .....	1315
mapping specification .....	596
milling_machine_cutting_tool	
application object .....	23, 111
ARM diagrams .....	1314
mapping specification .....	598
milling_machine_functions	

application assertion .....	199
application object .....	20, 112
ARM diagrams .....	1308
mapping specification .....	545
milling_machining_operation	
application object .....	20, 112
ARM diagrams .....	1304
mapping specification .....	554
milling_technology	
application object .....	20, 113
ARM diagrams .....	1307
mapping specification .....	555
milling_type_operation	
AIM diagrams .....	1348
AIM EXPRESS listing entities .....	1116
AIM EXPRESS short listing entities .....	904
application object .....	20, 113
ARM diagrams .....	1304
mapping specification .....	561
milling_type_strategy	
AIM diagrams .....	1347
AIM EXPRESS listing entities .....	1116
AIM EXPRESS short listing entities .....	905
minute_in_hour	
AIM diagrams .....	1402
AIM EXPRESS listing types .....	1001
mixed_loop_type_set	
AIM EXPRESS listing functions .....	1241
modified_geometric_tolerance	
AIM diagrams .....	1390
AIM EXPRESS listing entities .....	1118
modified_pattern	
AIM diagrams .....	1386
AIM EXPRESS listing entities .....	1118
month_in_year_number	
AIM diagrams .....	1402
AIM EXPRESS listing types .....	1001
msb_shells	
AIM EXPRESS listing functions .....	1242
msf_curve_check	
AIM EXPRESS listing functions .....	1242
msf_surface_check	
AIM EXPRESS listing functions .....	1243
multiple_arity_boolean_expression	
AIM diagrams .....	1398
AIM EXPRESS listing entities .....	1118
application object .....	16, 113
ARM diagrams .....	1334
mapping specification .....	443

multiple_arity_generic_expression	
AIM diagrams	1397
AIM EXPRESS listing entities	1119
multistep_drilling	
application object	21, 114
ARM diagrams	1305
mapping specification	562
multistep_grooving_strategy	
application object	25, 114
ARM diagrams	1311
mapping specification	661
name_attribute	
AIM diagrams	1409
AIM EXPRESS listing entities	1119
name_attribute_select	
AIM diagrams	1409
AIM EXPRESS listing types	1001
named_unit	
AIM diagrams	1396
AIM EXPRESS listing entities	1119
AIM EXPRESS short listing imported entity modifications	926
NC function	6
nc_constant	
application object	16, 114
ARM diagrams	1334
mapping specification	444
nc_function	
application object	16, 114
ARM diagrams	1298
mapping specification	444
nc_variable	
application object	16, 115
ARM diagrams	1300
mapping specification	444
nc_variable_compatible_initial_value	
AIM EXPRESS listing rules	1217
AIM EXPRESS short listing rules	936
next_assembly_usage_occurrence	
AIM diagrams	1359
AIM EXPRESS listing entities	1119
ngon_closed_profile	
AIM diagrams	1386
AIM EXPRESS listing entities	1119
ngon_profile	
application object	12, 115
ARM diagrams	1327
mapping specification	301
ngon_shape_representation	
AIM diagrams	1365

AIM EXPRESS listing entities .....	1121
AIM EXPRESS short listing entities .....	908
nmsf_curve_check	
AIM EXPRESS listing functions .....	1244
nmsf_surface_check	
AIM EXPRESS listing functions .....	1245
non_manifold_surface_shape_representation	
AIM diagrams .....	1365
AIM EXPRESS listing entities .....	1121
ARM diagrams .....	1344
non_sequential	
application object .....	16, 115
ARM diagrams .....	1298
mapping specification .....	445
normalise	
AIM EXPRESS listing functions .....	1246
not_expression	
AIM diagrams .....	1398
AIM EXPRESS listing entities .....	1124
application object .....	16, 115
ARM diagrams .....	1334
mapping specification .....	446
numeric_expression	
AIM diagrams .....	1398
AIM EXPRESS listing entities .....	1124
numeric_measure	
AIM diagrams .....	1394
AIM EXPRESS listing types .....	1001
numeric_parameter	
application object .....	9, 116
ARM diagrams .....	1336
mapping specification .....	226
numeric_variable	
AIM diagrams .....	1397
AIM EXPRESS listing entities .....	1124
AIM EXPRESS short listing imported entity modifications .....	927
numerical control (NC) .....	5
object_role	
AIM diagrams .....	1407
AIM EXPRESS listing entities .....	1124
offset_curve_3d	
AIM diagrams .....	1378
AIM EXPRESS listing entities .....	1124
offset_surface	
AIM diagrams .....	1373
AIM EXPRESS listing entities .....	1124
offset_vector	
application object .....	16, 116
ARM diagrams .....	1300

mapping specification .....	446
open_path_profile	
AIM diagrams .....	1386
AIM EXPRESS listing entities .....	1125
open_pocket	
application object .....	12, 116
ARM diagrams .....	1323
mapping specification .....	304
open_profile	
application object .....	12, 116
ARM diagrams .....	1327
mapping specification .....	306
open_shell	
AIM diagrams .....	1384
AIM EXPRESS listing entities .....	1125
ARM diagrams .....	1343
open_shell_reversed	
AIM EXPRESS listing functions .....	1247
open_slot_end_type	
application object .....	12, 117
ARM diagrams .....	1324
mapping specification .....	307
operation	
application assertion .....	198, 200
application object .....	18, 117
ARM diagrams .....	1301
mapping specification .....	475
operation UoF .....	17
optional_stop	
application object .....	16, 117
ARM diagrams .....	1298
mapping specification .....	447
or_expression	
AIM diagrams .....	1398
AIM EXPRESS listing entities .....	1126
application object .....	16, 117
ARM diagrams .....	1334
mapping specification .....	447
ordinal_date	
AIM diagrams .....	1402
AIM EXPRESS listing entities .....	1126
organization	
AIM diagrams .....	1399
AIM EXPRESS listing entities .....	1126
ARM diagrams .....	1342
organization_assignment	
AIM diagrams .....	1400
AIM EXPRESS listing entities .....	1126
organization_item	



AIM diagrams .....	1400
AIM EXPRESS listing types .....	1001
AIM EXPRESS short listing types .....	809
organization_role	
AIM diagrams .....	1400
AIM EXPRESS listing entities .....	1126
organizational_address	
AIM diagrams .....	1401
AIM EXPRESS listing entities .....	1126
oriented_closed_shell	
AIM diagrams .....	1384
AIM EXPRESS listing entities .....	1126
oriented_edge	
AIM diagrams .....	1383
AIM EXPRESS listing entities .....	1126
oriented_face	
AIM diagrams .....	1382
AIM EXPRESS listing entities .....	1127
oriented_open_shell	
AIM diagrams .....	1384
AIM EXPRESS listing entities .....	1127
oriented_path	
AIM diagrams .....	1383
AIM EXPRESS listing entities .....	1127
orthogonal_complement	
AIM EXPRESS listing functions .....	1247
outer_boundary_curve	
AIM diagrams .....	1380
AIM EXPRESS listing entities .....	1127
outer_diameter	
application object .....	24, 118
ARM diagrams .....	1326
mapping specification .....	637
outer_diameter_to_shoulder	
application object .....	24, 118
ARM diagrams .....	1326
mapping specification .....	640
outer_round	
AIM diagrams .....	1387
AIM EXPRESS listing entities .....	1128
application object .....	24, 118
ARM diagrams .....	1326
mapping specification .....	642
outside_profile	
AIM diagrams .....	1387
AIM EXPRESS listing entities .....	1130
parabola	
AIM diagrams .....	1379
AIM EXPRESS listing entities .....	1134

parallel	
application object	16, 118
ARM diagrams	1298
mapping specification	447
parallel_offset	
AIM diagrams	1388
AIM EXPRESS listing entities	1134
parallelism_tolerance	
AIM diagrams	1390
AIM EXPRESS listing entities	1134
application assertion	199
application object	27, 119
ARM diagrams	1331
mapping specification	732
parameter_value	
AIM diagrams	1394
AIM EXPRESS listing types	1001
ARM diagrams	1336
parameterised_path	
application object	18, 120
ARM diagrams	1302
mapping specification	494
parametric_representation_context	
AIM diagrams	1366
AIM EXPRESS listing entities	1134
part_property	
application assertion	200
application object	10, 120
ARM diagrams	1335
mapping specification	227
partial_area_definition	
application object	12, 120
ARM diagrams	1325
mapping specification	307
partial_circular_path	
application object	12, 120
ARM diagrams	1329
mapping specification	309
partial_circular_profile	
AIM diagrams	1386
AIM EXPRESS listing entities	1134
application object	12, 121
ARM diagrams	1327
mapping specification	310
partial_circular_shape_profile	
application object	12, 121
ARM diagrams	1324
mapping specification	313
path	

AIM diagrams	1383
AIM EXPRESS listing entities	1135
ARM diagrams	1343
path_feature_component	
AIM diagrams	1386
AIM EXPRESS listing entities	1135
path_head_to_tail	
AIM EXPRESS listing functions	1247
path_reversed	
AIM EXPRESS listing functions	1248
path_shape_item	
ARM diagrams	1329
path_shape_representation	
AIM diagrams	1365
AIM EXPRESS listing entities	1138
pathmode_type	
ARM diagrams	1310
pattern_offset_membership	
AIM diagrams	1388
AIM EXPRESS listing entities	1138
pattern_omit_membership	
AIM diagrams	1388
AIM EXPRESS listing entities	1141
pcurve	
AIM diagrams	1379
AIM EXPRESS listing entities	1143
pcurve_or_surface	
AIM diagrams	1379
AIM EXPRESS listing types	1001
perpendicular_to	
AIM diagrams	1388
AIM EXPRESS listing entities	1143
perpendicularity_tolerance	
AIM diagrams	1390
AIM EXPRESS listing entities	1143
application assertion	200
application object	27, 121
ARM diagrams	1331
mapping specification	733
person	
AIM diagrams	1399
AIM EXPRESS listing entities	1143
ARM diagrams	1342
person_and_address	
application object	9, 122
ARM diagrams	1337
mapping specification	217
person_and_organization	
AIM diagrams	1399

AIM EXPRESS listing entities .....	1143
ARM diagrams .....	1342
person_and_organization_assignment	
AIM diagrams .....	1399
AIM EXPRESS listing entities .....	1144
person_and_organization_item	
AIM diagrams .....	1399
AIM EXPRESS listing types .....	1001
AIM EXPRESS short listing types .....	809
person_and_organization_role	
AIM diagrams .....	1399
AIM EXPRESS listing entities .....	1144
person_organization_select	
AIM diagrams .....	1406
AIM EXPRESS listing types .....	1002
personal_address	
AIM diagrams .....	1401
AIM EXPRESS listing entities .....	1144
placed_datum_target_feature	
AIM diagrams .....	1389
AIM EXPRESS listing entities .....	1144
AIM EXPRESS short listing entities .....	909
placed_target	
application object .....	27, 123
ARM diagrams .....	1332
mapping specification .....	734
placement	
AIM diagrams .....	1370
AIM EXPRESS listing entities .....	1146
planar_face	
application object .....	12, 123
ARM diagrams .....	1323
mapping specification .....	314
planar_pocket_bottom_condition	
application object .....	12, 124
ARM diagrams .....	1323
mapping specification .....	319
planar_profile_floor	
application object .....	12, 124
ARM diagrams .....	1324
mapping specification .....	319
planar_shape_representation	
AIM diagrams .....	1365
AIM EXPRESS listing entities .....	1146
plane	
AIM diagrams .....	1373
AIM EXPRESS listing entities .....	1146
ARM diagrams .....	1343
plane_angle_measure	

AIM diagrams	1394
AIM EXPRESS listing types	1002
application object	8, 125
ARM diagrams	1341
mapping specification	209
plane_angle_measure_with_unit	
AIM diagrams	1393
AIM EXPRESS listing entities	1146
plane_angle_unit	
AIM diagrams	1396
AIM EXPRESS listing entities	1147
plane_cc_strategy	
application object	21, 125
ARM diagrams	1310
mapping specification	566
plane_cl_strategy	
application object	21, 125
ARM diagrams	1310
mapping specification	567
plane_finish_milling	
application object	21, 125
ARM diagrams	1304
mapping specification	568
plane_milling	
application object	21, 125
ARM diagrams	1304
mapping specification	568
plane_milling_operation	
AIM diagrams	1348
AIM EXPRESS listing entities	1147
AIM EXPRESS short listing entities	913
plane_rough_milling	
application object	21, 126
ARM diagrams	1304
mapping specification	570
plunge_helix	
application object	21, 126
ARM diagrams	1312
mapping specification	570
plunge_ramp	
application object	21, 126
ARM diagrams	1312
mapping specification	572
plunge_strategy	
application object	21, 126
ARM diagrams	1312
mapping specification	572
plunge_toolaxis	
application object	21, 127

ARM diagrams	1312
mapping specification	572
plunge_zigzag	
application object	21, 127
ARM diagrams	1312
mapping specification	573
plus_minus_tolerance	
AIM diagrams	1391
AIM EXPRESS listing entities	1147
plus_minus_value	
application assertion	202
application object	8, 127
ARM diagrams	1341
mapping specification	209
pocket	
AIM diagrams	1387
AIM EXPRESS listing entities	1147
application assertion	200
application object	12, 128
ARM diagrams	1323
mapping specification	320
pocket_bottom	
AIM diagrams	1386
AIM EXPRESS listing entities	1152
pocket_bottom_condition	
application object	12, 130
ARM diagrams	1323
mapping specification	329
point	
AIM diagrams	1370
AIM EXPRESS listing entities	1153
point_on_curve	
AIM diagrams	1371
AIM EXPRESS listing entities	1153
point_on_surface	
AIM diagrams	1371
AIM EXPRESS listing entities	1153
point_replica	
AIM diagrams	1370
AIM EXPRESS listing entities	1154
poly_loop	
AIM diagrams	1383
AIM EXPRESS listing entities	1154
polyline	
AIM diagrams	1378
AIM EXPRESS listing entities	1154
position_tolerance	
AIM diagrams	1390
AIM EXPRESS listing entities	1154

application assertion	200
application object	28, 130
ARM diagrams	1331
mapping specification	736
positive_length_measure	
AIM diagrams	1394
AIM EXPRESS listing types	1002
positive_plane_angle_measure	
AIM diagrams	1394
AIM EXPRESS listing types	1002
positive_ratio_measure	
ARM diagrams	1342
pre_defined_item	
AIM diagrams	1362
AIM EXPRESS listing entities	1154
precision_qualifier	
AIM diagrams	1395
AIM EXPRESS listing entities	1154
preferred_surface_curve_representation	
AIM diagrams	1379
AIM EXPRESS listing types	1002
pressure_measure	
application object	8, 131
ARM diagrams	1341
mapping specification	210
process data for milling UoF	7, 19
process data for turning UoF	24
process_model	
application object	21, 131
ARM diagrams	1308
mapping specification	574
process_model_list	
application object	21, 131
ARM diagrams	1308
mapping specification	575
process_product_association	
AIM diagrams	1351
AIM EXPRESS listing entities	1154
process_property	
application assertion	200
application object	10, 132
ARM diagrams	1335
mapping specification	227
process_property_association	
AIM diagrams	1351
AIM EXPRESS listing entities	1154
AIM EXPRESS short listing imported entity modifications	927
product	6
AIM diagrams	1356

AIM EXPRESS listing entities .....	1155
AIM EXPRESS short listing imported entity modifications .....	927
product data .....	6
product_category	
AIM diagrams .....	1357
AIM EXPRESS listing entities .....	1155
product_category_relationship	
AIM diagrams .....	1357
AIM EXPRESS listing entities .....	1155
product_context	
AIM diagrams .....	1358
AIM EXPRESS listing entities .....	1155
product_definition	
AIM diagrams .....	1356
AIM EXPRESS listing entities .....	1155
product_definition_context	
AIM diagrams .....	1358
AIM EXPRESS listing entities .....	1155
product_definition_formation	
AIM diagrams .....	1356
AIM EXPRESS listing entities .....	1155
AIM EXPRESS short listing imported entity modifications .....	927
product_definition_formation_with_specified_source	
AIM diagrams .....	1356
AIM EXPRESS listing entities .....	1156
product_definition_process	
AIM diagrams .....	1351
AIM EXPRESS listing entities .....	1156
product_definition_relationship	
AIM diagrams .....	1359
AIM EXPRESS listing entities .....	1156
product_definition_shape	
AIM diagrams .....	1360
AIM EXPRESS listing entities .....	1156
product_definition_usage	
AIM diagrams .....	1359
AIM EXPRESS listing entities .....	1156
product_definition_with_associated_documents	
AIM diagrams .....	1356
AIM EXPRESS listing entities .....	1156
product_related_product_category	
AIM diagrams .....	1357
AIM EXPRESS listing entities .....	1156
product_requires_version	
AIM EXPRESS listing rules .....	1217
AIM EXPRESS short listing rules .....	937
profile	
application object .....	12, 132
ARM diagrams .....	1327



mapping specification .....	330
profile_feature	
application object .....	12, 132
ARM diagrams .....	1324
mapping specification .....	332
profile_floor	
AIM diagrams .....	1386
AIM EXPRESS listing entities .....	1157
application object .....	12, 133
ARM diagrams .....	1324
mapping specification .....	334
profile_select	
ARM diagrams .....	1324
profiled_corner	
application object .....	26, 133
ARM diagrams .....	1317
mapping specification .....	703
profiled_end_mill	
application object .....	23, 133
ARM diagrams .....	1315
mapping specification .....	603
program structure .....	6
program_stop	
application object .....	16, 133
ARM diagrams .....	1298
mapping specification .....	447
program_structure	
application object .....	16, 134
ARM diagrams .....	1298
mapping specification .....	447
project .....	6
application assertion .....	198, 201
application object .....	9, 134
ARM diagrams .....	1297
mapping specification .....	217
project UoF .....	7, 9
projected_zone_definition	
AIM diagrams .....	1392
AIM EXPRESS listing entities .....	1158
projection	
application object .....	28, 134
ARM diagrams .....	1333
mapping specification .....	737
property_bsu	
application assertion .....	199, 200
application object .....	29, 135
ARM diagrams .....	1313
mapping specification .....	756
property_definition	

AIM diagrams	1360
AIM EXPRESS listing entities	1158
property_definition_representation	
AIM diagrams	1361
AIM EXPRESS listing entities	1159
property_or_shape_select	
AIM diagrams	1351
AIM EXPRESS listing types	1002
property_parameter	
application assertion	199, 200, 201
application object	9, 135
ARM diagrams	1336
mapping specification	227
property_process	
AIM diagrams	1351
AIM EXPRESS listing entities	1159
protocol implementation conformance statement (PICS)	6
protrusion	
AIM diagrams	1387
AIM EXPRESS listing entities	1159
qualified_representation_item	
AIM diagrams	1395
AIM EXPRESS listing entities	1160
qualitative_uncertainty	
AIM diagrams	1395
AIM EXPRESS listing entities	1160
quasi_uniform_curve	
AIM diagrams	1381
AIM EXPRESS listing entities	1160
quasi_uniform_surface	
AIM diagrams	1375
AIM EXPRESS listing entities	1160
radial_size_dimension	
application object	28, 135
ARM diagrams	1330
mapping specification	738
radiused_pocket_bottom_condition	
application object	12, 136
ARM diagrams	1323
mapping specification	335
radiused_slot_end_type	
application object	12, 137
ARM diagrams	1324
mapping specification	337
rapid_movement	
application object	16, 137
ARM diagrams	1301
mapping specification	448
ratio_measure	

AIM diagrams	1394
AIM EXPRESS listing types	1002
ratio_measure_with_unit	
AIM diagrams	1393
AIM EXPRESS listing entities	1160
ratio_unit	
AIM diagrams	1396
AIM EXPRESS listing entities	1160
rational_b_spline_curve	
AIM diagrams	1381
AIM EXPRESS listing entities	1160
rational_b_spline_surface	
AIM diagrams	1375
AIM EXPRESS listing entities	1161
real_literal	
AIM diagrams	1397
AIM EXPRESS listing entities	1161
real_numeric_variable	
AIM diagrams	1397
AIM EXPRESS listing entities	1161
reaming	
application object	21, 137
ARM diagrams	1305
mapping specification	575
reaming_cutting_tool	
application object	23, 137
ARM diagrams	1314
mapping specification	603
rectangular_closed_profile	
AIM diagrams	1386
AIM EXPRESS listing entities	1161
application object	12, 138
ARM diagrams	1327
mapping specification	337
rectangular_closed_shape_profile	
application object	13, 138
ARM diagrams	1324
mapping specification	340
rectangular_composite_surface	
AIM diagrams	1374
AIM EXPRESS listing entities	1162
rectangular_offset	
application object	13, 138
ARM diagrams	1321
mapping specification	341
rectangular_omit	
application object	13, 138
ARM diagrams	1321
mapping specification	345

rectangular_open_shape_profile	
application object	13, 139
ARM diagrams	1324
mapping specification	348
rectangular_pattern	
AIM diagrams	1387
AIM EXPRESS listing entities	1163
application object	13, 139
ARM diagrams	1321
mapping specification	349
rectangular_trimmed_surface	
AIM diagrams	1374
AIM EXPRESS listing entities	1165
referenced_modified_datum	
AIM diagrams	1389
AIM EXPRESS listing entities	1165
region	
application object	13, 139
ARM diagrams	1319
mapping specification	357
region_projection	
application object	13, 139
ARM diagrams	1319
mapping specification	358
region_surface_list	
application object	13, 140
ARM diagrams	1319
mapping specification	360
removal_volume	
AIM diagrams	1387
AIM EXPRESS listing entities	1165
reparametrised_composite_curve_segment	
AIM diagrams	1380
AIM EXPRESS listing entities	1166
replicate_feature	
AIM diagrams	1387
AIM EXPRESS listing entities	1166
application object	13, 140
ARM diagrams	1321
mapping specification	361
representation	
AIM diagrams	1364
AIM EXPRESS listing entities	1166
representation_context	
AIM diagrams	1366
AIM EXPRESS listing entities	1167
ARM diagrams	1344
representation_item	
AIM diagrams	1367

AIM EXPRESS listing entities .....	1167
representation_item_relationship	
AIM diagrams .....	1367
AIM EXPRESS listing entities .....	1167
AIM EXPRESS short listing imported entity modifications .....	928
representation_map	
AIM diagrams .....	1367
AIM EXPRESS listing entities .....	1167
representation_relationship	
AIM diagrams .....	1368
AIM EXPRESS listing entities .....	1167
representation_relationship_with_transformation	
AIM diagrams .....	1368
AIM EXPRESS listing entities .....	1167
represented_definition	
AIM diagrams .....	1361
AIM EXPRESS listing types .....	1002
requirement_for_action_resource	
AIM diagrams .....	1353
AIM EXPRESS listing entities .....	1168
resource_property	
AIM diagrams .....	1355
AIM EXPRESS listing entities .....	1168
resource_property_representation	
AIM diagrams .....	1355
AIM EXPRESS listing entities .....	1168
resource_requirement_type	
AIM diagrams .....	1353
AIM EXPRESS listing entities .....	1168
restrict_unneeded_feature_usage	
AIM EXPRESS listing rules .....	1217
AIM EXPRESS short listing rules .....	938
restricted_area_select	
ARM diagrams .....	1340
return_home	
application object .....	16, 140
ARM diagrams .....	1301
mapping specification .....	448
reversible_topology	
AIM diagrams .....	1377
AIM EXPRESS listing types .....	1002
reversible_topology_item	
AIM diagrams .....	1377
AIM EXPRESS listing types .....	1002
revolved_feature	
application object .....	24, 140
ARM diagrams .....	1326
mapping specification .....	642
revolved_flat	

application object	24, 141
ARM diagrams	1326
mapping specification	644
revolved_profile	
AIM diagrams	1387
AIM EXPRESS listing entities	1168
revolved_round	
application object	24, 141
ARM diagrams	1326
mapping specification	645
rib_top	
AIM diagrams	1387
AIM EXPRESS listing entities	1170
rib_top_floor	
AIM diagrams	1386
AIM EXPRESS listing entities	1170
right_circular_cylinder	
AIM diagrams	1377
AIM EXPRESS listing entities	1171
ARM diagrams	1343
role_association	
AIM diagrams	1407
AIM EXPRESS listing entities	1172
role_select	
AIM diagrams	1407
AIM EXPRESS listing types	1003
rot_direction	
ARM diagrams	1309
rot_speed_measure	
application object	8, 141
ARM diagrams	1341
mapping specification	211
rotating_boring_cutting_tool	
application object	23, 141
ARM diagrams	1314
mapping specification	604
roughing	6
round_hole	
AIM diagrams	1387
AIM EXPRESS listing entities	1172
application assertion	195, 200
application object	13, 142
ARM diagrams	1322
mapping specification	361
rounded_corner	
application object	26, 143
ARM diagrams	1317
mapping specification	704
rounded_end	

AIM diagrams	1387
AIM EXPRESS listing entities	1173
application object	13, 144
ARM diagrams	1322
mapping specification	367
rounded_u_profile	
AIM diagrams	1386
AIM EXPRESS listing entities	1174
application object	13, 144
ARM diagrams	1328
mapping specification	369
roundness_tolerance	
AIM diagrams	1390
AIM EXPRESS listing entities	1175
application object	28, 145
ARM diagrams	1331
mapping specification	738
runout_zone_definition	
AIM diagrams	1392
AIM EXPRESS listing entities	1175
runout_zone_orientation	
AIM diagrams	1392
AIM EXPRESS listing entities	1175
runout_zone_orientation_reference_direction	
AIM diagrams	1392
AIM EXPRESS listing entities	1175
rvalue	
ARM diagrams	1334
scalar_times_vector	
AIM EXPRESS listing functions	1248
seam_curve	
AIM diagrams	1379
AIM EXPRESS listing entities	1175
second_in_minute	
AIM diagrams	1402
AIM EXPRESS listing types	1003
second_proj_axis	
AIM EXPRESS listing functions	1248
security_classification	
AIM diagrams	1407
AIM EXPRESS listing entities	1176
AIM EXPRESS short listing imported entity modifications	928
application assertion	201
application object	29, 145
ARM diagrams	1338
mapping specification	762
security_classification_assignment	
AIM diagrams	1407
AIM EXPRESS listing entities	1176

AIM EXPRESS short listing imported entity modifications	928
application assertion	200, 201
application object	30, 146
ARM diagrams	1338
mapping specification	763
security_classification_item	
AIM diagrams	1407
AIM EXPRESS listing types	1003
AIM EXPRESS short listing types	810
ARM diagrams	1338
security_classification_level	
AIM diagrams	1407
AIM EXPRESS listing entities	1176
security_classification_requires_assignment	
AIM EXPRESS listing rules	1218
AIM EXPRESS short listing rules	939
selective	
application object	16, 146
ARM diagrams	1298
mapping specification	448
sequential_method	
AIM diagrams	1350
AIM EXPRESS listing entities	1176
serial_action_method	
AIM diagrams	1350
AIM EXPRESS listing entities	1176
set_mark	
application object	16, 147
ARM diagrams	1298
mapping specification	448
set_of_reversible_topology_item	
AIM diagrams	1377
AIM EXPRESS listing types	1003
set_of_topology_reversed	
AIM EXPRESS listing functions	1249
set_representation_item	
AIM diagrams	1368
AIM EXPRESS listing types	1003
setup	
application object	16, 147
ARM diagrams	1297
mapping specification	448
setup_instruction	
application object	16, 147
ARM diagrams	1297
mapping specification	450
shape_aspect	
AIM diagrams	1386
AIM EXPRESS listing entities	1176



AIM EXPRESS short listing imported entity modifications .....	928
shape_aspect_deriving_relationship	
AIM diagrams .....	1388
AIM EXPRESS listing entities .....	1176
shape_aspect_relationship	
AIM diagrams .....	1388
AIM EXPRESS listing entities .....	1176
shape_defining_relationship	
AIM diagrams .....	1388
AIM EXPRESS listing entities .....	1177
shape_definition	
AIM diagrams .....	1360
AIM EXPRESS listing types .....	1003
shape_definition_representation	
AIM diagrams .....	1361
AIM EXPRESS listing entities .....	1177
shape_dimension_representation	
AIM diagrams .....	1365
AIM EXPRESS listing entities .....	1177
shape_element	
ARM diagrams .....	1333
shape_profile	
application object .....	13, 147
ARM diagrams .....	1324
mapping specification .....	371
shape_representation	
AIM diagrams .....	1365
AIM EXPRESS listing entities .....	1177
ARM diagrams .....	1344
shape_representation_relationship	
AIM diagrams .....	1368
AIM EXPRESS listing entities .....	1177
shape_representation_with_parameters	
AIM diagrams .....	1365
AIM EXPRESS listing entities .....	1177
shell	
AIM diagrams .....	1385
AIM EXPRESS listing types .....	1003
shell_based_surface_model	
AIM diagrams .....	1385
AIM EXPRESS listing entities .....	1178
shell_based_wireframe_model	
AIM diagrams .....	1385
AIM EXPRESS listing entities .....	1178
shell_based_wireframe_shape_representation	
AIM diagrams .....	1365
AIM EXPRESS listing entities .....	1178
ARM diagrams .....	1344
shell_reversed	

AIM EXPRESS listing functions .....	1249
shouldermill	
application object .....	23, 148
ARM diagrams .....	1315
mapping specification .....	605
si_prefix	
AIM diagrams .....	1396
AIM EXPRESS listing types .....	1003
si_unit	
AIM diagrams .....	1396
AIM EXPRESS listing entities .....	1180
si_unit_name	
AIM diagrams .....	1396
AIM EXPRESS listing types .....	1004
side_finish_milling	
application object .....	21, 148
ARM diagrams .....	1304
mapping specification .....	575
side_mill	
application object .....	23, 148
ARM diagrams .....	1315
mapping specification .....	605
side_milling	
application object .....	21, 148
ARM diagrams .....	1304
mapping specification .....	575
side_milling_operation	
AIM diagrams .....	1348
AIM EXPRESS listing entities .....	1180
AIM EXPRESS short listing entities .....	914
side_rough_milling	
application object .....	21, 149
ARM diagrams .....	1304
mapping specification .....	578
simple_entity_instance .....	6
simple_generic_expression	
AIM diagrams .....	1397
AIM EXPRESS listing entities .....	1180
simple_numeric_expression	
AIM diagrams .....	1397
AIM EXPRESS listing entities .....	1181
single_datum	
application assertion .....	196, 201
application object .....	28, 149
ARM diagrams .....	1332
mapping specification .....	738
size_dimension	
application object .....	28, 149
ARM diagrams .....	1330

mapping specification .....	739
slot	
AIM diagrams .....	1387
AIM EXPRESS listing entities .....	1181
application object .....	13, 150
ARM diagrams .....	1324
mapping specification .....	373
slot_end	
AIM diagrams .....	1386
AIM EXPRESS listing entities .....	1183
slot_end_type	
application object .....	13, 151
ARM diagrams .....	1324
mapping specification .....	376
solid_angle_measure	
AIM diagrams .....	1394
AIM EXPRESS listing types .....	1004
solid_angle_measure_with_unit	
AIM diagrams .....	1393
AIM EXPRESS listing entities .....	1184
solid_angle_unit	
AIM diagrams .....	1396
AIM EXPRESS listing entities .....	1184
solid_model	
AIM diagrams .....	1384
AIM EXPRESS listing entities .....	1185
source	
AIM diagrams .....	1356
AIM EXPRESS listing types .....	1004
source_item	
AIM diagrams .....	1362
AIM EXPRESS listing types .....	1004
spade_drill	
application object .....	23, 151
ARM diagrams .....	1315
mapping specification .....	606
specification	
application assertion .....	197
application object .....	13, 151
ARM diagrams .....	1325
mapping specification .....	376
specification_usage_constraint	
application object .....	13, 151
ARM diagrams .....	1325
mapping specification .....	377
speed_measure	
application object .....	8, 152
ARM diagrams .....	1341
mapping specification .....	211

speed_name	
ARM diagrams	1302
speed_select	
ARM diagrams	1307
spherical_cap	
AIM diagrams	1387
AIM EXPRESS listing entities	1185
application object	13, 152
ARM diagrams	1322
mapping specification	377
spherical_hole_bottom	
application object	13, 152
ARM diagrams	1322
mapping specification	379
spherical_surface	
AIM diagrams	1376
AIM EXPRESS listing entities	1185
spotdrill	
application object	23, 152
ARM diagrams	1315
mapping specification	606
square_u_profile	
AIM diagrams	1386
AIM EXPRESS listing entities	1186
application object	13, 153
ARM diagrams	1328
mapping specification	380
standard_uncertainty	
AIM diagrams	1395
AIM EXPRESS listing entities	1188
step	
AIM diagrams	1387
AIM EXPRESS listing entities	1188
application object	13, 153
ARM diagrams	1322
mapping specification	386
step_drill	
application object	23, 154
ARM diagrams	1315
mapping specification	606
straight_knurl	
application object	24, 154
ARM diagrams	1326
mapping specification	646
straightness_tolerance	
AIM diagrams	1390
AIM EXPRESS listing entities	1189
application object	28, 154
ARM diagrams	1331

mapping specification .....	739
stroke_connection_strategy	
ARM diagrams .....	1309
supplier_bsu	
application assertion .....	196
application object .....	29, 155
ARM diagrams .....	1313
mapping specification .....	757
supported_item	
AIM diagrams .....	1352
AIM EXPRESS listing types .....	1005
surface	
AIM diagrams .....	1373
AIM EXPRESS listing entities .....	1189
surface_curve	
AIM diagrams .....	1379
AIM EXPRESS listing entities .....	1189
surface_of_linear_extrusion	
AIM diagrams .....	1373
AIM EXPRESS listing entities .....	1190
surface_of_revolution	
AIM diagrams .....	1373
AIM EXPRESS listing entities .....	1190
surface_patch	
AIM diagrams .....	1374
AIM EXPRESS listing entities .....	1190
surface_profile_tolerance	
AIM diagrams .....	1390
AIM EXPRESS listing entities .....	1190
application assertion .....	201
application object .....	28, 155
ARM diagrams .....	1331
mapping specification .....	740
surface_property	
application assertion .....	201
application object .....	10, 156
ARM diagrams .....	1335
mapping specification .....	228
surface_replica	
AIM diagrams .....	1373
AIM EXPRESS listing entities .....	1190
surface_texture_parameter	
application object .....	13, 156
ARM diagrams .....	1336
mapping specification .....	389
surface_texture_representation	
AIM diagrams .....	1364
AIM EXPRESS listing entities .....	1191
AIM EXPRESS short listing entities .....	915

surface_weights_positive	
AIM EXPRESS listing functions	1249
swept_surface	
AIM diagrams	1373
AIM EXPRESS listing entities	1191
symmetric_shape_aspect	
AIM diagrams	1389
AIM EXPRESS listing entities	1191
symmetry_tolerance	
AIM diagrams	1390
AIM EXPRESS listing entities	1191
application assertion	201
application object	28, 157
ARM diagrams	1331
mapping specification	741
t_slot_mill	
application object	23, 157
ARM diagrams	1315
mapping specification	608
tangent	
AIM diagrams	1388
AIM EXPRESS listing entities	1191
taper	
AIM diagrams	1386
AIM EXPRESS listing entities	1191
taper_select	
ARM diagrams	1322
tapered_drill	
application object	23, 158
ARM diagrams	1315
mapping specification	609
tapered_reamer	
application object	23, 158
ARM diagrams	1314
mapping specification	610
tapping	
application object	21, 158
ARM diagrams	1305
mapping specification	578
tapping_cutting_tool	
application object	23, 158
ARM diagrams	1314
mapping specification	611
tapping_operation	
AIM diagrams	1348
AIM EXPRESS listing entities	1193
AIM EXPRESS short listing entities	915
target_area	
application object	28, 159

ARM diagrams . . . . .	1332
mapping specification . . . . .	741
target_circle	
application object . . . . .	28, 159
ARM diagrams . . . . .	1332
mapping specification . . . . .	742
target_point	
application object . . . . .	28, 159
ARM diagrams . . . . .	1332
mapping specification . . . . .	742
target_rectangle	
application object . . . . .	28, 159
ARM diagrams . . . . .	1332
mapping specification . . . . .	743
target_straight_line	
application object . . . . .	28, 160
ARM diagrams . . . . .	1332
mapping specification . . . . .	744
technology	
application object . . . . .	18, 160
ARM diagrams . . . . .	1307
mapping specification . . . . .	476
tee_profile	
AIM diagrams . . . . .	1386
AIM EXPRESS listing entities . . . . .	1193
application object . . . . .	13, 160
ARM diagrams . . . . .	1328
mapping specification . . . . .	391
text	
AIM diagrams . . . . .	1411
AIM EXPRESS listing types . . . . .	1005
ARM diagrams . . . . .	1342
thickness_size_dimension	
application assertion . . . . .	201
application object . . . . .	28, 161
ARM diagrams . . . . .	1330
mapping specification . . . . .	745
thread	
AIM diagrams . . . . .	1387
AIM EXPRESS listing entities . . . . .	1196
application object . . . . .	13, 161
ARM diagrams . . . . .	1325
mapping specification . . . . .	398
thread_cut_depth_type	
ARM diagrams . . . . .	1310
thread_drilling	
application object . . . . .	21, 162
ARM diagrams . . . . .	1305
mapping specification . . . . .	579

thread_hand_type	
ARM diagrams	1316
thread_mill	
application object	23, 162
ARM diagrams	1315
mapping specification	615
thread_profile_type	
ARM diagrams	1316
thread_runout	
AIM diagrams	1386
AIM EXPRESS listing entities	1200
thread_strategy	
application object	25, 162
ARM diagrams	1310
mapping specification	661
thread_type	
ARM diagrams	1316
threading	
application object	25, 163
ARM diagrams	1306
mapping specification	665
threading_direction_type	
ARM diagrams	1310
threading_finish	
application object	25, 163
ARM diagrams	1306
mapping specification	665
threading_rough	
application object	25, 163
ARM diagrams	1306
mapping specification	665
threading_turning_operation	
AIM diagrams	1348
AIM EXPRESS listing entities	1201
AIM EXPRESS short listing entities	916
three_axes	
application object	18, 164
ARM diagrams	1301
mapping specification	478
three_axes_tilted_tool	
application object	21, 164
ARM diagrams	1301
mapping specification	580
through_bottom_condition	
application object	13, 164
ARM diagrams	1322
mapping specification	408
through_pocket_bottom_condition	
application object	14, 164



ARM diagrams	1323
mapping specification	408
through_profile_floor	
application object	14, 164
ARM diagrams	1324
mapping specification	408
time_measure	
AIM diagrams	1394
AIM EXPRESS listing types	1005
application object	8, 165
ARM diagrams	1341
mapping specification	211
time_measure_with_unit	
AIM diagrams	1393
AIM EXPRESS listing entities	1201
time_unit	
AIM diagrams	1396
AIM EXPRESS listing entities	1201
tolerance	5
tolerance_condition	
application assertion	197, 201
application object	28, 165
ARM diagrams	1332
mapping specification	746
tolerance_method_definition	
AIM diagrams	1391
AIM EXPRESS listing types	1005
tolerance_value	
AIM diagrams	1391
AIM EXPRESS listing entities	1202
tolerance_zone	
AIM diagrams	1392
AIM EXPRESS listing entities	1202
application assertion	202
application object	28, 165
ARM diagrams	1333
mapping specification	746
tolerance_zone_definition	
AIM diagrams	1392
AIM EXPRESS listing entities	1202
application assertion	202
application object	28, 166
ARM diagrams	1333
mapping specification	746
tolerance_zone_form	
AIM diagrams	1392
AIM EXPRESS listing entities	1202
toleranced_length_measure	
application object	8, 167

ARM diagrams . . . . .	1341
mapping specification . . . . .	211
tolerances	
application object . . . . .	21, 167
ARM diagrams . . . . .	1310
mapping specification . . . . .	580
tool path . . . . .	5
tool_direction	
application object . . . . .	18, 167
ARM diagrams . . . . .	1301
mapping specification . . . . .	478
tool_direction_for_milling	
application object . . . . .	21, 167
ARM diagrams . . . . .	1301
mapping specification . . . . .	581
tool_knurl	
application object . . . . .	24, 168
ARM diagrams . . . . .	1326
mapping specification . . . . .	646
tool_length_probing	
application object . . . . .	16, 168
ARM diagrams . . . . .	1300
mapping specification . . . . .	451
tool_probing	
application object . . . . .	16, 168
ARM diagrams . . . . .	1300
mapping specification . . . . .	451
tool_radius_probing	
application object . . . . .	16, 168
ARM diagrams . . . . .	1300
mapping specification . . . . .	454
tool_reference_point	
ARM diagrams . . . . .	1307
tool_usage	
application assertion . . . . .	199, 202
application object . . . . .	17, 169
ARM diagrams . . . . .	1313
mapping specification . . . . .	454
toolpath	
application assertion . . . . .	198, 201
application object . . . . .	18, 170
ARM diagrams . . . . .	1302
mapping specification . . . . .	494
toolpath UoF . . . . .	7, 18
toolpath_feature	
application object . . . . .	14, 170
ARM diagrams . . . . .	1322
mapping specification . . . . .	408
toolpath_list	

application object	18, 171
ARM diagrams	1301
mapping specification	478
toolpath_speed	
application object	19, 171
ARM diagrams	1302
mapping specification	498
toolpath_speedprofile	
ARM diagrams	1302
toolpath_type	
ARM diagrams	1302
topological_region	
application object	14, 171
ARM diagrams	1319
mapping specification	409
topological_representation_item	
AIM diagrams	1382
AIM EXPRESS listing entities	1202
topology_reversed	
AIM EXPRESS listing functions	1250
toroidal_surface	
AIM diagrams	1376
AIM EXPRESS listing entities	1202
total_runout_tolerance	
AIM diagrams	1390
AIM EXPRESS listing entities	1202
application assertion	202
application object	28, 172
ARM diagrams	1331
mapping specification	747
touch_probe	
application object	16, 173
ARM diagrams	1300
mapping specification	456
touch_probing	
application object	16, 173
ARM diagrams	1300
mapping specification	456
trajectory	
application object	19, 173
ARM diagrams	1303
mapping specification	498
transformation	
AIM diagrams	1369
AIM EXPRESS listing types	1005
transition_code	
AIM diagrams	1374
AIM EXPRESS listing types	1005
transition_feature	

AIM diagrams	1386
AIM EXPRESS listing entities	1203
application object	14, 175
ARM diagrams	1320
mapping specification	410
travel_path	
application object	14, 175
ARM diagrams	1329
mapping specification	411
trimmed_curve	
AIM diagrams	1378
AIM EXPRESS listing entities	1203
trimming_preference	
AIM diagrams	1378
AIM EXPRESS listing types	1005
trimming_select	
AIM diagrams	1378
AIM EXPRESS listing types	1005
turned_knurl	
AIM diagrams	1387
AIM EXPRESS listing entities	1203
turning feature UoF	23
turning_feature	
application object	24, 176
ARM diagrams	1326
mapping specification	647
turning_machine_cutting_tool	
application object	26, 176
ARM diagrams	1316
mapping specification	704
turning_machine_functions	
application object	25, 176
ARM diagrams	1308
mapping specification	666
turning_machining_operation	
application object	25, 177
ARM diagrams	1306
mapping specification	673
turning_machining_strategy	
application object	25, 177
ARM diagrams	1311
mapping specification	674
turning_technology	
application object	25, 177
ARM diagrams	1307
mapping specification	678
turning_threading_tool	
application object	26, 178
ARM diagrams	1316

mapping specification .....	710
turning_type_operation	
AIM diagrams .....	1348
AIM EXPRESS listing entities .....	1206
AIM EXPRESS short listing entities .....	917
turning_type_strategy	
AIM diagrams .....	1347
AIM EXPRESS listing entities .....	1206
AIM EXPRESS short listing entities .....	918
turning_workingstep	
application object .....	25, 178
ARM diagrams .....	1299
mapping specification .....	682
twist_drill	
application object .....	23, 178
ARM diagrams .....	1315
mapping specification .....	618
two_axes	
application object .....	18, 179
ARM diagrams .....	1301
mapping specification .....	478
two5d_manufacturing_feature	
application object .....	14, 179
ARM diagrams .....	1319
mapping specification .....	412
two5d_milling_operation	
application object .....	21, 179
ARM diagrams .....	1304
mapping specification .....	581
two5d_milling_strategy	
application object .....	21, 179
ARM diagrams .....	1309
mapping specification .....	582
type_qualifier	
AIM diagrams .....	1395
AIM EXPRESS listing entities .....	1209
unary_boolean_expression	
AIM diagrams .....	1398
AIM EXPRESS listing entities .....	1209
application object .....	16, 180
ARM diagrams .....	1334
mapping specification .....	457
unary_generic_expression	
AIM diagrams .....	1397
uncertainty_measure_with_unit	
AIM diagrams .....	1393
AIM EXPRESS listing entities .....	1209
uncertainty_qualifier	
AIM diagrams .....	1395

AIM EXPRESS listing entities .....	1210
unidirectional	
application object .....	21, 180
ARM diagrams .....	1309
mapping specification .....	583
unidirectional_turning	
application object .....	25, 180
ARM diagrams .....	1311
mapping specification .....	684
uniform_curve	
AIM diagrams .....	1381
AIM EXPRESS listing entities .....	1210
uniform_surface	
AIM diagrams .....	1375
AIM EXPRESS listing entities .....	1210
unit	
AIM diagrams .....	1393
AIM EXPRESS listing types .....	1005
unit of functionality (UoF) .....	6
unload_tool	
application object .....	22, 180
ARM diagrams .....	1298
mapping specification .....	585
user_defined_milling_tool	
application object .....	23, 181
ARM diagrams .....	1314
mapping specification .....	618
user_defined_turning_tool	
application object .....	26, 182
ARM diagrams .....	1316
mapping specification .....	715
using_items	
AIM EXPRESS listing functions .....	1250
using_representations	
AIM EXPRESS listing functions .....	1251
uv_strategy	
application object .....	22, 183
ARM diagrams .....	1310
mapping specification .....	585
valid_calendar_date	
AIM EXPRESS listing functions .....	1251
valid_geometrically_bounded_wf_curve	
AIM EXPRESS listing functions .....	1252
valid_geometrically_bounded_wf_point	
AIM EXPRESS listing functions .....	1253
valid_measure_value	
AIM EXPRESS listing functions .....	1253
valid_time	
AIM EXPRESS listing functions .....	1254

valid_units	
AIM EXPRESS listing functions	1254
valid_wireframe_edge_curve	
AIM EXPRESS listing functions	1255
valid_wireframe_vertex_point	
AIM EXPRESS listing functions	1255
value_qualifier	
AIM diagrams	1395
AIM EXPRESS listing types	1005
value_range	
AIM diagrams	1368
AIM EXPRESS listing entities	1210
AIM EXPRESS short listing entities	924
application assertion	197
application object	9, 183
ARM diagrams	1341
mapping specification	212
value_representation_item	
AIM diagrams	1367
AIM EXPRESS listing entities	1210
value_with_tolerance	
application assertion	197, 202
application object	9, 183
ARM diagrams	1341
mapping specification	214
value_with_unit	
application object	9, 184
ARM diagrams	1341
mapping specification	216
variable	
AIM diagrams	1397
AIM EXPRESS listing entities	1210
variable_semantics	
AIM diagrams	1397
AIM EXPRESS listing entities	1210
vector	
AIM diagrams	1370
AIM EXPRESS listing entities	1210
vector_difference	
AIM EXPRESS listing functions	1255
vector_or_direction	
AIM diagrams	1370
AIM EXPRESS listing types	1005
vee_profile	
AIM diagrams	1386
AIM EXPRESS listing entities	1210
application object	14, 184
ARM diagrams	1328
mapping specification	413

verify_angle_measure_action_property	
AIM EXPRESS listing functions	1256
AIM EXPRESS short listing functions	943, 944
verify_angle_measure_rep_item	
AIM EXPRESS listing functions	1257
AIM EXPRESS short listing functions	943
verify_angle_measure_resource_property	
AIM EXPRESS listing functions	1257
verify_angle_measure_tool_body_item	
AIM EXPRESS listing functions	1257
AIM EXPRESS short listing functions	945
verify_ballnose_endmill_dimensions	
AIM EXPRESS listing functions	1257
AIM EXPRESS short listing functions	945
verify_bullnose_endmill_dimensions	
AIM EXPRESS listing functions	1257
AIM EXPRESS short listing functions	946
verify_count_measure_action_property	
AIM EXPRESS listing functions	1258
AIM EXPRESS short listing functions	946
verify_count_measure_rep_item	
AIM EXPRESS listing functions	1258
AIM EXPRESS short listing functions	947
verify_count_measure_resource_property	
AIM EXPRESS listing functions	1259
AIM EXPRESS short listing functions	948
verify_count_measure_tool_body_item	
AIM EXPRESS listing functions	1259
AIM EXPRESS short listing functions	949
verify_descriptive_action_property	
AIM EXPRESS listing functions	1259
AIM EXPRESS short listing functions	949
verify_enumeration_action_property	
AIM EXPRESS listing functions	1259
AIM EXPRESS short listing functions	950
verify_enumeration_measure_tool_body_item	
AIM EXPRESS short listing functions	951
verify_enumeration_resource_property	
AIM EXPRESS listing functions	1260
AIM EXPRESS short listing functions	951
verify_enumeration_tool_body_item	
AIM EXPRESS listing functions	1260
verify_length_measure_action_property	
AIM EXPRESS listing functions	1261
AIM EXPRESS short listing functions	952, 953
verify_length_measure_rep_item	
AIM EXPRESS listing functions	1261
AIM EXPRESS short listing functions	953
verify_length_measure_resource_property	



AIM EXPRESS listing functions .....	1261
verify_length_measure_tool_body_item	
AIM EXPRESS listing functions .....	1261
AIM EXPRESS short listing functions .....	954
verify_linear_speed_measure_rep_item	
AIM EXPRESS listing functions .....	1261
AIM EXPRESS short listing functions .....	954
verify_numeric_measure_action_property	
AIM EXPRESS listing functions .....	1262
AIM EXPRESS short listing functions .....	955
verify_optional_action_property	
AIM EXPRESS listing functions .....	1262
AIM EXPRESS short listing functions .....	956
verify_optional_in_process_geometry	
AIM EXPRESS listing functions .....	1262
AIM EXPRESS short listing functions .....	956
verify_optional_relating_amr	
AIM EXPRESS listing functions .....	1263
AIM EXPRESS short listing functions .....	957
verify_optional_relating_amr_with_name	
AIM EXPRESS listing functions .....	1263
AIM EXPRESS short listing functions .....	958
verify_optional_rep_item	
AIM EXPRESS listing functions .....	1263
AIM EXPRESS short listing functions .....	959
verify_optional_resource_property	
AIM EXPRESS listing functions .....	1263
AIM EXPRESS short listing functions .....	959
verify_optional_tool_body_item	
AIM EXPRESS listing functions .....	1263
AIM EXPRESS short listing functions .....	960
verify_pressure_measure_action_property	
AIM EXPRESS listing functions .....	1264
AIM EXPRESS short listing functions .....	960
verify_ratio_measure_action_property	
AIM EXPRESS listing functions .....	1264
AIM EXPRESS short listing functions .....	961
verify_ratio_measure_rep_item	
AIM EXPRESS listing functions .....	1264
AIM EXPRESS short listing functions .....	961
verify_related_type_for_amr	
AIM EXPRESS listing functions .....	1264
AIM EXPRESS short listing functions .....	962
verify_related_type_for_amr_with_name	
AIM EXPRESS listing functions .....	1264
AIM EXPRESS short listing functions .....	963
verify_rep_item_for_action_property	
AIM EXPRESS listing functions .....	1265
AIM EXPRESS short listing functions .....	963

verify_rep_item_for_resource_property	
AIM EXPRESS listing functions	1265
AIM EXPRESS short listing functions	964
verify_rep_item_for_tool_body	
AIM EXPRESS listing functions	1266
AIM EXPRESS short listing functions	965
verify_rep_name_for_action_property	
AIM EXPRESS listing functions	1266
AIM EXPRESS short listing functions	966
verify_rep_type_for_action_property	
AIM EXPRESS listing functions	1266
AIM EXPRESS short listing functions	966
verify_rep_type_for_resource_property	
AIM EXPRESS listing functions	1266
AIM EXPRESS short listing functions	967
verify_required_action_property	
AIM EXPRESS listing functions	1267
AIM EXPRESS short listing functions	968
verify_required_relating_amr	
AIM EXPRESS listing functions	1267
AIM EXPRESS short listing functions	968
verify_required_relating_amr_with_name	
AIM EXPRESS listing functions	1267
AIM EXPRESS short listing functions	969
verify_required_rep_item	
AIM EXPRESS listing functions	1267
AIM EXPRESS short listing functions	969
verify_required_resource_property	
AIM EXPRESS listing functions	1267
AIM EXPRESS short listing functions	970
verify_required_tool_body_item	
AIM EXPRESS listing functions	1267
AIM EXPRESS short listing functions	970
verify_rotary_speed_measure_rep_item	
AIM EXPRESS listing functions	1268
AIM EXPRESS short listing functions	971
verify_time_measure_action_property	
AIM EXPRESS listing functions	1268
AIM EXPRESS short listing functions	972, 973
verify_time_measure_rep_item	
AIM EXPRESS listing functions	1268
AIM EXPRESS short listing functions	972
verify_time_measure_resource_property	
AIM EXPRESS listing functions	1268
vertex	
AIM diagrams	1382
AIM EXPRESS listing entities	1213
vertex_loop	
AIM diagrams	1383

AIM EXPRESS listing entities .....	1213
vertex_point	
AIM diagrams .....	1382
AIM EXPRESS listing entities .....	1213
vertex_shell	
AIM diagrams .....	1385
AIM EXPRESS listing entities .....	1213
volume_measure	
AIM diagrams .....	1394
AIM EXPRESS listing types .....	1006
application object .....	9, 185
ARM diagrams .....	1341
mapping specification .....	216
wait_for_mark	
application object .....	16, 185
ARM diagrams .....	1298
mapping specification .....	457
week_in_year_number	
AIM diagrams .....	1402
AIM EXPRESS listing types .....	1006
week_of_year_and_day_date	
AIM diagrams .....	1402
AIM EXPRESS listing entities .....	1213
while_statement	
application object .....	17, 186
ARM diagrams .....	1298
mapping specification .....	458
width_size_dimension	
application assertion .....	202
application object .....	28, 186
ARM diagrams .....	1330
mapping specification .....	748
wire_shell	
AIM diagrams .....	1385
AIM EXPRESS listing entities .....	1213
wireframe_model	
AIM diagrams .....	1385
AIM EXPRESS listing types .....	1006
woodruff_slot_end_type	
application object .....	14, 186
ARM diagrams .....	1324
mapping specification .....	418
workingstep .....	6
application object .....	17, 187
ARM diagrams .....	1299
mapping specification .....	459
workpiece	
application assertion .....	197, 198, 201, 202, 203, 204
application object .....	9, 187

ARM diagrams	1318
mapping specification	229
workpiece UoF	7, 9
workpiece_assembly_component	
application assertion	204
application object	10, 192
ARM diagrams	1337
mapping specification	239
workpiece_complete_probing	
application object	17, 193
ARM diagrams	1300
mapping specification	460
workpiece_probing	
application object	17, 193
ARM diagrams	1300
mapping specification	462
workpiece_setup	
application object	17, 194
ARM diagrams	1297
mapping specification	465
workplan	6
application assertion	204
application object	17, 194
ARM diagrams	1297
mapping specification	469
xor_expression	
AIM diagrams	1398
AIM EXPRESS listing entities	1213
application object	17, 194
ARM diagrams	1334
mapping specification	472
year_number	
AIM diagrams	1402
AIM EXPRESS listing types	1006

---

---

**ICS 25.040.40**

Price based on 204 pages