

INTERNATIONAL
STANDARD

ISO
10262

First edition
1998-06-15

Earth-moving machinery — Hydraulic excavators — Laboratory tests and performance requirements for operator protective guards

Engins de terrassement — Pelles hydrauliques — Essais de laboratoire et critères de performance des structures de protection de l'opérateur



Reference number
ISO 10262:1998(E)

Foreword

ISO (the International Organization for Standardization) is a worldwide federation of national standards bodies (ISO member bodies). The work of preparing International Standards is normally carried out through ISO technical committees. Each member body interested in a subject for which a technical committee has been established has the right to be represented on that committee. International organizations, governmental and non-governmental, in liaison with ISO, also take part in the work. ISO collaborates closely with the International Electrotechnical Commission (IEC) on all matters of electrotechnical standardization.

Draft International Standards adopted by the technical committees are circulated to the member bodies for voting. Publication as an International Standard requires approval by at least 75 % of the member bodies casting a vote.

International Standard ISO 10262 was prepared by Technical Committee ISO/TC 127, *Earth-moving machinery*, Subcommittee SC 2, *Safety requirements and human factors*.

Annex A forms an integral part of this International Standard.

© ISO 1998

All rights reserved. Unless otherwise specified, no part of this publication may be reproduced or utilized in any form or by any means, electronic or mechanical, including photocopying and microfilm, without permission in writing from the publisher.

International Organization for Standardization
Case postale 56 • CH-1211 Genève 20 • Switzerland
Internet iso@iso.ch

Printed in Switzerland

Earth-moving machinery — Hydraulic excavators — Laboratory tests and performance requirements for operator protective guards

1 Scope

This International Standard establishes a consistent, repeatable test procedure and performance requirements for evaluating operator-protective guarding that undergo loading. Such guards are usually intended to provide excavator operators with reasonable protection against objects (e.g. rocks and debris) which would otherwise penetrate the operators station from the front or top.

It is applicable to hydraulic excavators, as defined in ISO 7135 when equipped with an operator's station guard(s).

2 Normative references

The following standards contain provisions which, through reference in this text, constitute provisions of this International Standard. At the time of publication, the editions indicated were valid. All standards are subject to revision, and parties to agreements based on this International Standard are encouraged to investigate the possibility of applying the most recent editions of the standards indicated below. Members of IEC and ISO maintain registers of currently valid International Standards.

ISO 148:1983, *Steel — Charpy impact test (V-notch)*.

ISO 898-1:—¹⁾, *Mechanical properties of fasteners made of carbon steel and alloy steel — Part 1: Bolts, screws and studs*.

ISO 898-2:1992, *Mechanical properties of fasteners — Part 2: Nuts with specified proof load values — Coarse thread*.

ISO 3164:1995, *Earth-moving machinery — Laboratory evaluations of protective structures — Specifications for deflection-limiting volume*.

ISO 5353:1995, *Earth-moving machinery, and tractors and machinery for agriculture and forestry— Seat index point*.

ISO 7135:—²⁾, *Earth-moving machinery — Hydraulic excavators — Terminology and commercial specifications*.

3 Definitions

For the purposes of this International Standard, the following definitions and abbreviations apply.

3.1

operator guards

system of a **top guard** (3.3) and a **front guard** (3.2) for the operator station of excavators

1) To be published. (Revision of ISO 898-1:1988)

2) To be published. (Revision of ISO 7135:1993)

3.2 front guard

device intended to provide object protection to the front of the operator station of excavators

3.3 top guard

device intended to provide falling object protection to the top of the operator station of excavators

3.4 deflection-limiting volume DLV

that volume, related to the operator, which serves to set limits and deflections permissible when performing laboratory evaluations of ROPS³⁾ and FOPS⁴⁾

NOTE — The volume, an approximation, is based on the seated dimensions of a large male operator. Adapted from ISO 3164:1995.

3.5 drop test object

object meeting the criteria outlined for either Level I or Level II acceptance used in structural loading testing

4 General

4.1 The operator station shall be equipped accordingly with respect to the use of the machine and against risk of falling and/or approaching objects, with one of the following arrangements:

- a top guard providing protection from falling objects;
- a front guard providing protection from objects that approach from the front;
- a combination of top and front guarding.

4.2 The areas protected include:

- an area which shall be not less than the horizontal projection of the DLV for front guards providing protection from objects approaching the front of the operator's station;
- an area which shall be not less than the vertical projection of the DLV for top guards providing protection from objects falling on the upper area of the operator's station.

4.3 Resistance to penetration of the guard to the point of infringement of the DLV is evaluated. The performance requirements of a representative specimen (i.e. within the manufacturer's specifications) are based on the performance of a proven structure under laboratory evaluation procedures.

4.4 Two acceptance levels are defined as follows:

- a) Level I acceptance is intended for protection from small objects, e.g. small rocks, small debris and other small objects encountered in operations such as highway maintenance, landscaping and other construction site services;
- b) Level II acceptance is intended for protection from large objects, e.g. large rocks, large debris and other large objects encountered in applications such as construction and demolition.

Compact excavators having a mass of 6 000 kg or less are excluded from acceptance Level II.

3) ROPS: Roll-over protective structure.

4) FOPS: Falling object protective structure.

4.5 Guards meeting the following criteria may not give crush protection under all conceivable circumstances of the machine being struck from above or the front. Nonetheless, it can be expected that crush protection will be ensured under at least the loading conditions specified in the following tests.

5 Laboratory tests

5.1 Apparatus for testing the top guard

5.1.1 **Drop test object for Level I testing**, made of solid steel or ductile iron, with a spherical contact surface and a diameter not exceeding 250 mm (see figure 1), possessing the potential energy required. See 8.1 or 8.2 and figure 2 to determine the mass and/or drop-height ratio necessary to obtain the required energy. Typical mass is 46 kg for Level I.

5.1.2 **Drop test object for Level II testing**, made of steel, designed as shown in figure 1, and possessing the potential energy required for loading. See 8.1 or 8.2 and figure 2 to determine the mass and/or drop height ratio necessary to obtain the required energy. Typical mass is 227 kg for Level II.

Dimensions in millimetres

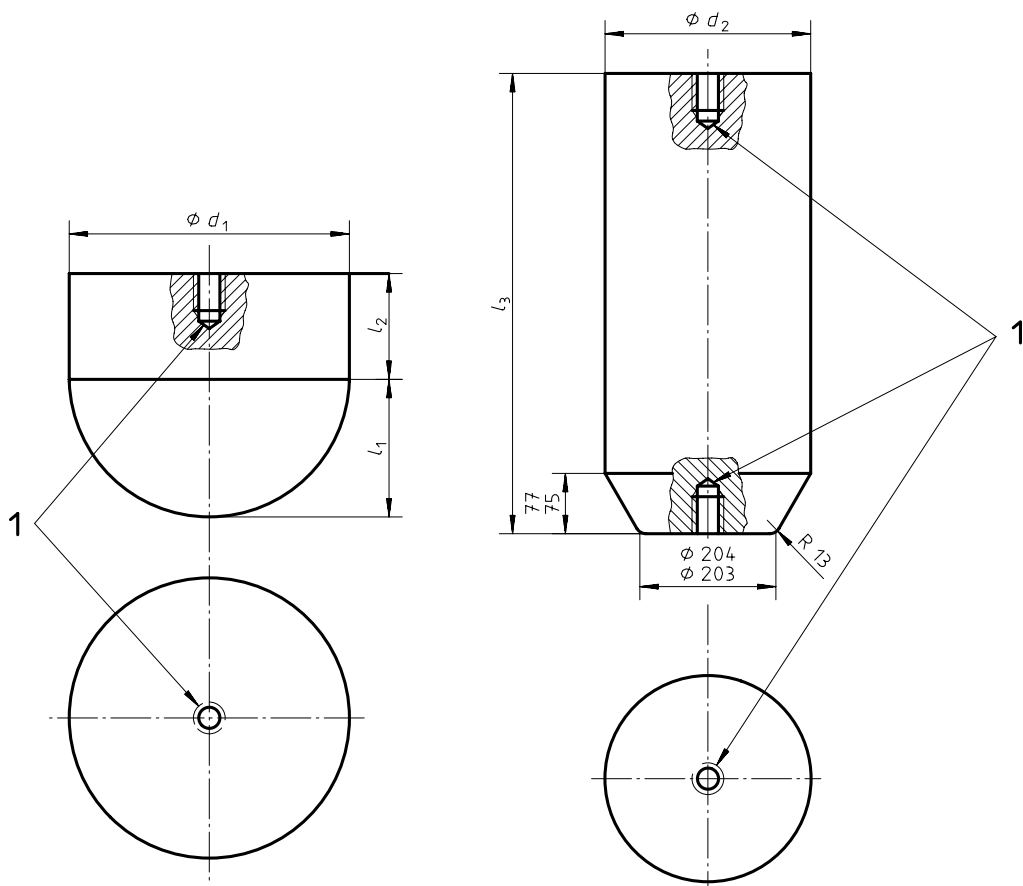

Key

1 May be drilled and tapped for lifting eye.

$\phi d_1 \approx 204$; $\phi d_2 = 255$ to 260 ; $l_1 \approx 102$; $l_2 \approx 68$; $l_3 = 583$ to 585

a) Level I: mass weighing 46 kg

b) Level II: mass weighing 227 kg

NOTE — Dimensions d_1 , d_2 , l_1 , l_2 and l_3 are optional. Dimensions of the drop test object are determined with respect to both its mass and drop height (as determined from figure 2) that shall provide the required energy.

Figure 1 — Examples of laboratory drop test object

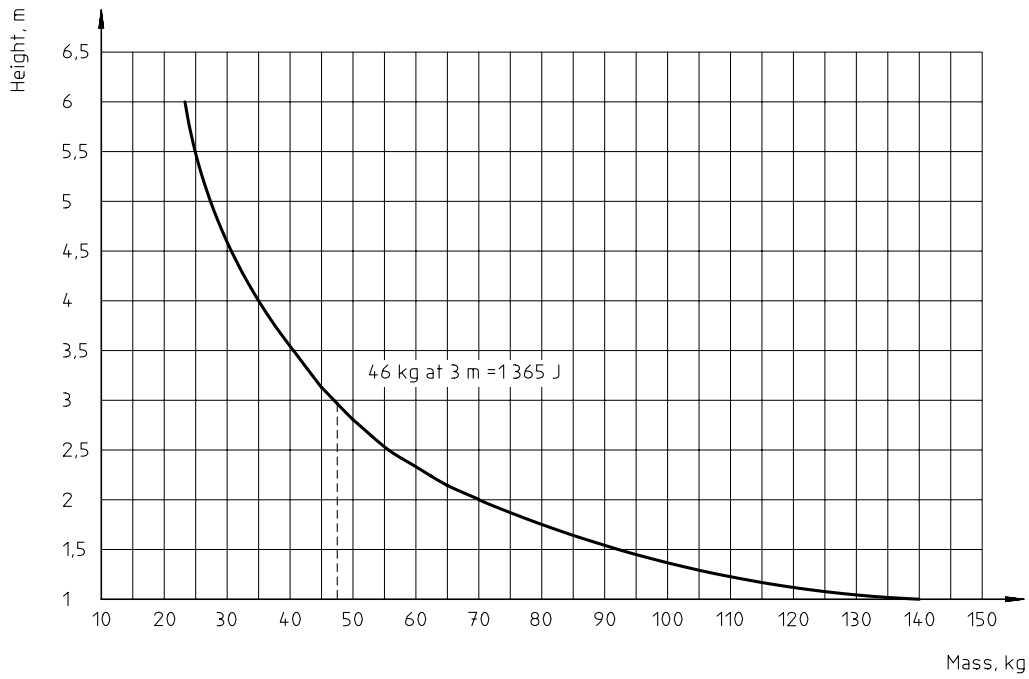

a) Level I energy requirement curve
Energy required: 1 365 J

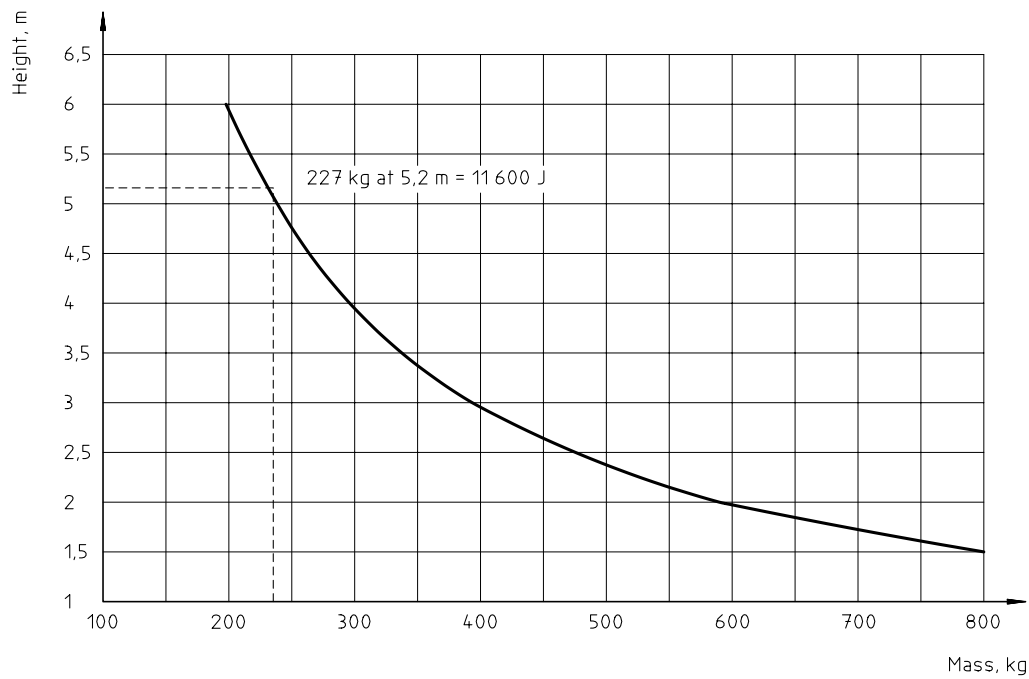

b) Level II energy requirement curve
Energy required: 11 600 J

Figure 2 — Height and mass for drop test object necessary to meet energy requirements

5.1.3 Apparatus, providing the following:

- a means of raising the standard object to the required height;
- a means of releasing the standard object so that it drops without restraint;
- a surface that cannot be penetrated by the machine or test bed when undergoing loading during the drop test;
- a means of determining whether the operator guard(s) penetrates the deflection-limiting volume during the drop test which may be either
 - a DLV, placed upright, made of a material which indicates any penetration by the operator guard(s). Grease may be put on either the lower surface of the cover or the top of the DLV to indicate such penetration; or
 - a dynamic instrumentation system of sufficient frequency response to indicate the relevant deflection with respect to the DLV.

5.2 Apparatus for testing the front guard

5.2.1 Standard laboratory penetration test object, made of steel, with the shape of the tapered end of the object in figure 1. The object length shall be sufficient to avoid a diameter larger than 260 mm making contact with the front guard during test.

5.2.2 Apparatus, providing the following:

- a means of pushing the object into the front guard;
- a means of measuring the force exerted to push the object into the front guard;
- a means of determining the test object or front guard penetration of the DLV, during the push test. This may be a DLV, placed upright, made of a material which indicates any penetration by the operator guard(s). Grease or similar substance put either on the front of the DLV or on the inner surface of the front guard to indicate penetration. The DLV shall be positioned at the SIP⁵⁾ (see ISO 5353 and ISO 3164) and fixed firmly to the same part of the machine to which the operator seat is secured;
- a means of simultaneously measuring the deflection distance and the force used to push the object into the front guard.

5.3 Optional dynamic test

5.3.1 The front guard may be submitted to an optional dynamic test using a device (see figure 1) that results in equivalent energy absorbed by the guard.

5.3.2 The operator station base shall be provided with the same relative base firmness as that of the normal machine arrangement so as to restrict unnatural energy absorption by the operator station during the optional dynamic test. Furthermore, the test surface under the operator station shall be of such firmness that it is not penetrated by the arrangement when loaded.

6 Test conditions

6.1 Measurement accuracy

The measurement accuracy of the deflection of the guard shall be $\pm 5\%$ of the maximum deflection measured.

5) SIP: Seat index point

6.2 Machine or test bed condition

6.2.1 The operator guards to be evaluated shall be attached to the machine in the same manner as in actual machine use. A complete machine is not required; however, the portion to which the operator guards are mounted shall be identical to the structure on the complete machine.

6.2.2 If the operator guards are mounted on a machine, the following apply:

- a) for the test, the machine may be equipped with customary attachments provided their position does not interfere with the test of the guards;
- b) all ground engaging tools shall be in normal carrying positions;
- c) all suspension systems including pneumatic tyres, shall be set at operating levels, with variable suspensions set in the "hard" range.

6.2.3 All cab elements, such as windows, normally removable panels, or non-structural fittings, that do not contribute to the strength of the operator guards shall be removed.

6.2.4 The guards to be tested shall be representative of units within the manufacturer's specifications.

7 Test procedure

7.1 General

It is the intent of this procedure to evaluate the area of the top guard and front guard with the least resistance to penetration. If design features such as cut-outs for windows or equipment or variations in cover material or thickness indicate an area with lower penetration resistance within the vertical and horizontal projections of the DLV, the drop or static location should be adjusted accordingly. In addition, if cut-outs in the top guard or front guard cover are intended to be filled with devices to provide adequate protection, those devices or equivalent ones shall be in place during the drop or static test.

7.2 Top guard test

7.2.1 The appropriate laboratory drop test object (figure 1) shall be placed on top of the top guard (small end of the object down) at the location designated in 7.2.2, 7.2.3, and 7.2.4. It is intended that the drop location include at least a portion of the vertical projection of the top plane area of the DLV. If it does not, two drop tests shall be required; one to be located within the top plane area as far as possible from major, upper, structure members; and the other to be as defined in 7.2.2, 7.2.3, and 7.2.4. Also, where other materials or a different thickness are used in different areas above the DLV, each area in turn shall be subjected to a drop test. These tests may be performed on the same top guard.

7.2.2 The small end of the object shall be entirely within the vertical projection of the DLV on the top guard.

7.2.3 Accounting for the requirements of 7.2.2, the small end of the object shall be placed closest to the top most point of the DLV and to the centroid of the largest unsupported area on the top guard (i.e. the area not supported by major, upper, structural members).

7.2.4 Should the vertical projection of the DLV be divided into two, or more segments by vertical projections of major, upper, structural members, the requirements of 7.2.2 and 7.2.3 shall apply to the segment containing the largest area of the DLV projection. See figure 3.

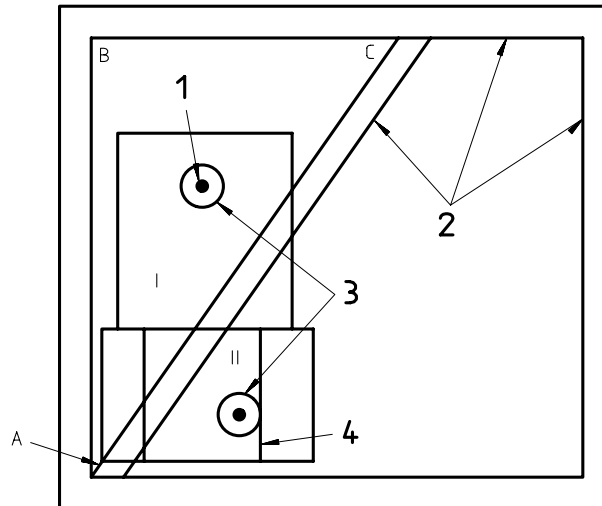

Key

- 1 Centroid for A-B-C
- 2 Major structural members
- 3 Drop object
- 4 DLV top plane

NOTE — Area I and area II represent segmented vertical projections of the DLV area onto the top guard. Area I is larger than area II.

Figure 3 — Drop test impact point for a top guard

7.2.5 The drop test object shall be raised vertically to a height above the position specified in 7.2.2 and 7.2.3 to obtain the potential energy specified in 8.1. The drop test object shall be released so that it falls without restraint onto the guard.

7.2.6 As it is unlikely that a free fall will result in the object hitting the exact location and/or be in the impact position as described in 7.2.1 to 7.2.4, the deviations are limited as indicated in 7.2.6.1 to 7.2.6.4.

7.2.6.1 For a Level I guard, the initial impact of the small end of the object shall be entirely within a circle of 100 mm radius. (The centre of this circle is to coincide with the vertical centreline of the object as positioned according to 7.2.1 to 7.2.4, but not on any major, upper, horizontal member.)

7.2.6.2 For a Level II guard, the initial impact of the small end of the object shall be entirely within a circle of 200 mm radius. (The centre of this circle is to coincide with the vertical centreline of the object as positioned according to 7.2.1 to 7.2.4, but not on any major, upper, horizontal member.)

7.2.6.3 For a Level I guard, the first contact between the object and the guard shall be made by the spherical end of the drop test object. For a Level II guard, the first contact between the object and the top guard shall be made by the small end of the drop test object. See figure 1.

7.2.6.4 There are no requirements on the location or impact position of subsequent impacts due to rebound.

7.3 Front guard test

7.3.1 Static test

7.3.1.1 The small end of the appropriate laboratory penetration test object shall be placed against the front guard at the location designated in 7.3.1.2 to 7.3.1.4.

7.3.1.2 The small end of the object shall be entirely within the horizontal projection of the DLV on the front guard closest to the front most point of the DLV and to the centroid of the largest unsupported area on the front guard (i.e. the area not supported by major structural members). See figure 4.

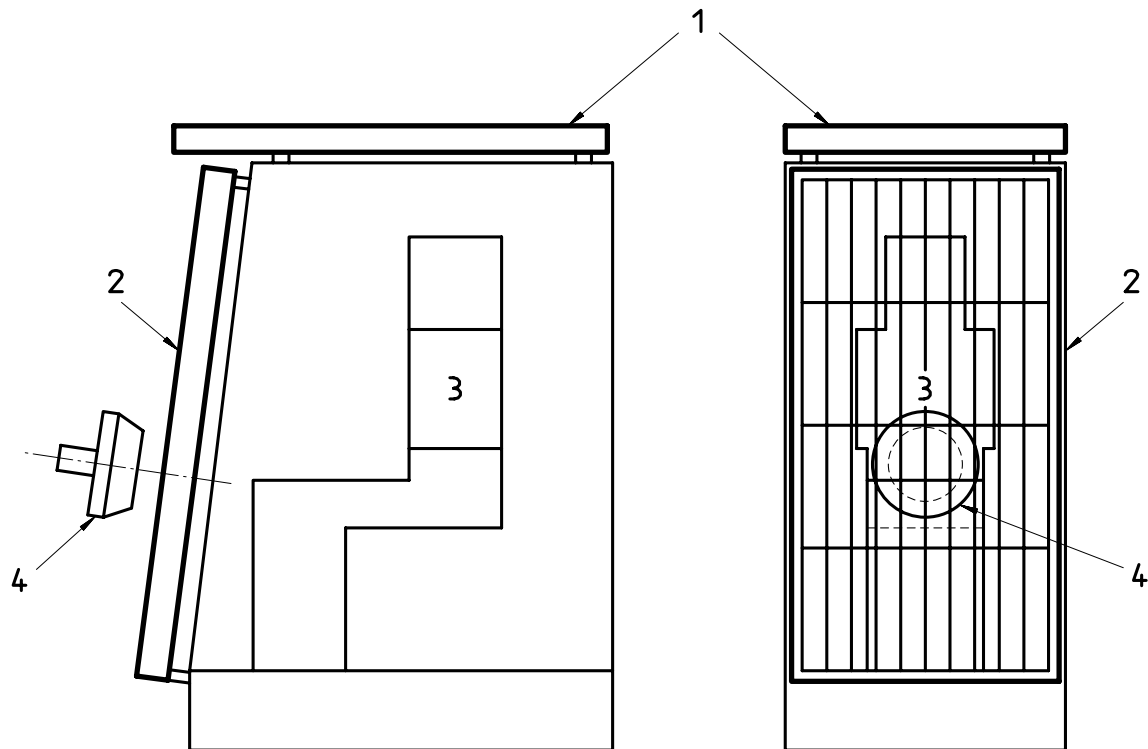

Key

- 1 Top guard
- 2 Front guard
- 3 DLV
- 4 Load object

Figure 4 — Test object location

7.3.1.3 Should the horizontal projection of the DLV be divided into two, or more segments by major structural members, the requirements of 7.3.1.1 and 7.3.1.2 shall apply to the segment containing the largest area closest to the DLV projection. See figure 4.

7.3.1.4 The object shall be pushed in a plane perpendicular to the front guard surface at the location(s) indicated in 7.3.1.2 and 7.3.1.3.

7.3.1.5 The rate of deflection shall be such that the loading can be considered static. The rate of load application can be considered static provided the rate of deflection at the load application point is not greater than 5 mm/s.

7.3.1.6 Force and deflection at deflection increments no greater than 15 mm, measured at the point of application of the load shall be recorded.

7.3.1.7 Loading shall continue until the front guard has achieved the energy requirements given in 8.1. (See figure 5 for the method of calculating energy). The deflection used in calculating energy shall be the displacement of the front guard along the line of action of the force. The line of action of the load object shall be maintained within a circle of 50 mm radius of the initial contact point.

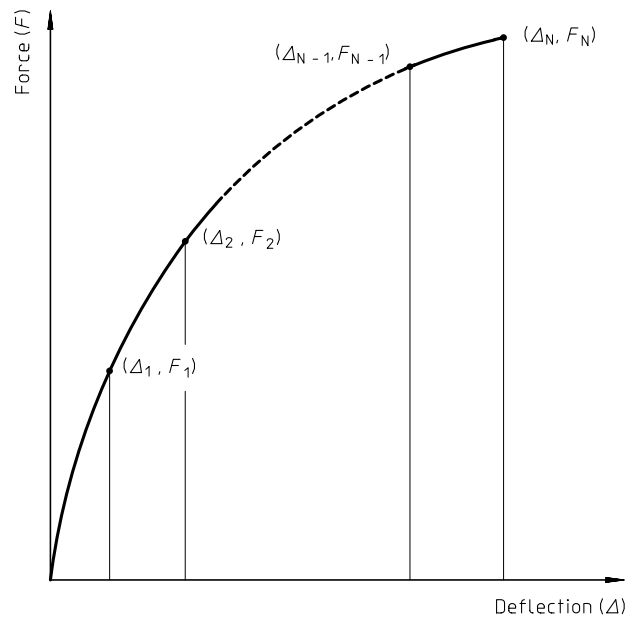

Calculation of energy:

$$U = \frac{\Delta_1 F_1}{2} + (\Delta_2 - \Delta_1) \frac{F_1 + F_2}{2} + \dots + (\Delta_N - \Delta_{N-1}) \frac{F_{N-1} + F_N}{2}$$

Figure 5 — Force-deflection curve

7.3.2 Dynamic test

The front guard may be dynamically tested with a device that results in equivalent energy applied to the guard. If electing to use this option, the drop test object outlined for use with an overhead guard test can be used. See figure 4. The procedures described in 7.2 can be used to determine the drop height and mass for the required energy. The drop test location shall be defined according to 7.3.1.1 to 7.3.1.3.

8 Performance

8.1 Top guard test

The protective properties of the top guard shall be estimated by the ability of the cab or protective structure to resist impact. The DLV (see ISO 3164) shall not be penetrated by any part of the protective structure under the first or subsequent impacts of the test object at the energy levels listed below:

- a) Level I: absorbed energy 1 365 J;
- b) Level II: absorbed energy 11 600 J.

If the test object penetrates through the top guard, it shall be considered to have failed the test.

8.2 Front guard test

During the test no part of the front guard or the operator station shall penetrate the DLV (see 5.2) at the energy levels for the required performance level

- a) Level I: absorbed energy 700 J;
- b) Level II: absorbed energy 5 800 J.

If the test object penetrates through the top guard, it shall be considered to have failed the test.

8.3 Material requirements

8.3.1 In addition to the performance requirements, there are material requirements to ensure that the guards will have meaningful resistance to brittle fracture. This requirement is met when all guards and mounting material in a manufacturer's representative specimen meets the required toughness characteristics. To ensure structural integrity at low temperatures, material selection, design, and weld considerations shall emphasize high density and toughness, i.e. the ability to resist brittle fracture of the structure.

This requirement may be met by conducting the laboratory tests with all structural members at, or below $-18\text{ }^{\circ}\text{C}$, provided material specifications and procurement assure that materials in the guards subsequently manufactured have toughness characteristics similar to those in the tested representative specimen. Alternatively, the requirement may be met by applying the loading at a higher temperature provided all of the structural members of the guards are fabricated from materials meeting the mechanical requirements given in 8.3.2 to 8.3.4.

8.3.1 Bolts used structurally shall be metric property class 8.8, 9.8 or 10.9 (ISO 898-1). Nuts used structurally shall be metric property class 8 or 10 (ISO 898-2).

8.3.2 In those countries using the inch system, bolts and nuts used shall be of an equivalent grade.

8.3.3 Structural members of the guard and the mounts which attach the guard to the machine shall be made of steels meeting or exceeding one of the Charpy V-notch (CVN) impact strengths as shown in the table 1. Specimens are to be "longitudinal" and taken from flat stock, tubular, or structural sections before forming or welding for use in the guard. Specimens from tubular or structural sections shall be taken from the middle of the side of greatest dimension and shall not include welds. See ISO 148.

NOTE — The Charpy V-notch evaluation is primarily a quality control check and the indicated temperature does not directly relate to operating conditions.

Table 1 — Minimum Charpy V-notch impact strengths

Specimen size mm	Energy requirements ¹⁾ ($-30\text{ }^{\circ}\text{C}$) J	Specimen size mm	Energy requirements ¹⁾ ($-30\text{ }^{\circ}\text{C}$) J
$10 \times 10^{2)}$	11,0	10×6	8,0
10×9	10,0	$10 \times 5^{2)}$	7,5
10×8	9,5	10×4	7,0
$10 \times 7,5^{2)}$	9,5	$10 \times 3,3$	6,0
10×7	9,0	10×3	6,0
$10 \times 6,7$	8,5	$20 \times 2,5^{2)}$	5,5

1) An alternative energy requirement may be allowed at $-20\text{ }^{\circ}\text{C}$. The energy requirement at $-20\text{ }^{\circ}\text{C}$ is 2,5 times the value specified for $-30\text{ }^{\circ}\text{C}$. Other factors affect impact energy strength, i.e. direction of rolling, yield strength, grain orientation and welding. These shall be considered in selecting a steel.

2) Indicates preferred size. Specimen size shall be no less than the largest preferred size that the material will permit.

Structural members made from materials other than steel shall have equivalent low temperature impact resistance.

8.3.4 Steel less than 2,5 mm in thickness with a maximum carbon content of 0,20 % shall be considered to meet the Charpy V-notch requirements.

9 Labelling

Falling object guards meeting the requirements of this International Standard shall be labelled according to 9.1 and 9.2.

9.1 Label specifications

9.1.1 The label shall be of a permanent type and permanently attached to the structure.

9.1.2 The label shall be located on the structure so as to be read easily and to be protected from defacing by weather.

9.2 Label content

The following information shall be specified on the label:

- a) name and address of the manufacturer or constructor of the guard;
- b) identification number of the guard, if any;
- c) machine make, model(s), or serial number(s) the guard is designed to fit;
- d) reference to the International Standard(s) for which the guard meets all of the performance requirements and the level being met (national regulations may be included);
- e) the manufacturer may include such other information as deemed appropriate (for example, installation, repair or replacement information).

10 Reporting of test results

The test report shall include the results of the test and be presented in a typical test report in accordance with annex A.

Annex A (normative)

Standard test report

A.1 Identification

A.1.1 Machine(s)

Type: _____

Manufacturer: _____

Model: _____

Serial number (if any): _____

Machine frame part number: _____

A.1.2 Operator guards

A.1.2.1 Top guard

Manufacturer: _____

Model: _____

Serial number (if any): _____

Guard part number: _____

A.1.2.2 Front guard

Manufacturer: _____

Model: _____

Serial number (if any): _____

Front Guard part number: _____

A.2 Information supplied by manufacturer(s)

Location of DLV: _____

A.3 Conclusion

Confirm the test results by the following:

1) The minimum performance requirements of ISO 10262 were met (not met) in this test

2) Date of test: _____

3) Name and address of the test facility:

4) Tested by (signature):

5) Date of report: _____

ICS 53.100

Descriptors: earth-moving equipment, hydraulic excavators, accident prevention, operator protection, protection against falling objects, safety devices, machine guards, specifications, materials specifications, performance, tests, laboratory tests, performance tests, test report sheets, labelling.

Price based on 12 pages
