

---

---

**Protective equipment for use in ice  
hockey —**

**Part 4:  
Head and face protection for  
goalkeepers**

*Équipements de protection destinés à être utilisés en hockey sur  
glace —*

*Partie 4: Protections de tête et de visage pour les gardiens de but*





**COPYRIGHT PROTECTED DOCUMENT**

© ISO 2016, Published in Switzerland

All rights reserved. Unless otherwise specified, no part of this publication may be reproduced or utilized otherwise in any form or by any means, electronic or mechanical, including photocopying, or posting on the internet or an intranet, without prior written permission. Permission can be requested from either ISO at the address below or ISO's member body in the country of the requester.

ISO copyright office  
Ch. de Blandonnet 8 • CP 401  
CH-1214 Vernier, Geneva, Switzerland  
Tel. +41 22 749 01 11  
Fax +41 22 749 09 47  
copyright@iso.org  
www.iso.org

# Contents

	Page
<b>Foreword</b> .....	<b>iv</b>
<b>Introduction</b> .....	<b>v</b>
<b>1 Scope</b> .....	<b>1</b>
<b>2 Normative references</b> .....	<b>1</b>
<b>3 Terms and definitions</b> .....	<b>1</b>
<b>4 Requirements</b> .....	<b>2</b>
4.1 General.....	2
4.2 Design.....	2
4.2.1 Padding.....	2
4.2.2 Load-bearing area.....	2
4.2.3 Welded wire components.....	2
4.2.4 Overlap.....	2
4.2.5 Minimum distance (headform to face protector).....	3
4.2.6 Maximum distance (headform to face protector).....	3
4.3 Protected areas (coverage).....	3
4.3.1 Protected area of the head.....	3
4.3.2 Protected area of the face.....	3
4.4 Penetration resistance.....	3
4.4.1 General.....	3
4.4.2 Types D1 and D2.....	3
4.4.3 Type D3.....	3
4.5 Shock-absorbing capacity.....	3
4.6 Puck impact resistance.....	3
4.6.1 Contact test.....	3
4.6.2 Toughness test.....	4
4.7 Retention system.....	4
4.8 Field of vision.....	4
<b>5 Test methods</b> .....	<b>4</b>
5.1 General.....	4
5.1.1 Tolerances and uncertainty estimations.....	4
5.1.2 Samples.....	4
5.1.3 Component assemblies.....	5
5.2 Conditioning.....	5
5.3 Protector positioning.....	5
5.4 Protected area (coverage) test.....	5
5.4.1 Protected area of the head.....	5
5.4.2 Protected area of the face.....	5
5.4.3 Coverage test.....	5
5.5 Penetration test.....	5
5.5.1 Test apparatus.....	5
5.5.2 Procedures.....	6
5.6 Shock absorbing capacity test.....	6
5.7 Puck impact resistance test.....	6
<b>6 Test report</b> .....	<b>6</b>
<b>7 Permanent marking</b> .....	<b>6</b>
<b>8 Information for users</b> .....	<b>7</b>

## Foreword

ISO (the International Organization for Standardization) is a worldwide federation of national standards bodies (ISO member bodies). The work of preparing International Standards is normally carried out through ISO technical committees. Each member body interested in a subject for which a technical committee has been established has the right to be represented on that committee. International organizations, governmental and non-governmental, in liaison with ISO, also take part in the work. ISO collaborates closely with the International Electrotechnical Commission (IEC) on all matters of electrotechnical standardization.

The procedures used to develop this document and those intended for its further maintenance are described in the ISO/IEC Directives, Part 1. In particular the different approval criteria needed for the different types of ISO documents should be noted. This document was drafted in accordance with the editorial rules of the ISO/IEC Directives, Part 2 (see [www.iso.org/directives](http://www.iso.org/directives)).

Attention is drawn to the possibility that some of the elements of this document may be the subject of patent rights. ISO shall not be held responsible for identifying any or all such patent rights. Details of any patent rights identified during the development of the document will be in the Introduction and/or on the ISO list of patent declarations received (see [www.iso.org/patents](http://www.iso.org/patents)).

Any trade name used in this document is information given for the convenience of users and does not constitute an endorsement.

For an explanation on the meaning of ISO specific terms and expressions related to conformity assessment, as well as information about ISO's adherence to the World Trade Organization (WTO) principles in the Technical Barriers to Trade (TBT) see the following URL: [www.iso.org/iso/foreword.html](http://www.iso.org/iso/foreword.html).

The committee responsible for this document is ISO/TC 83, *Sports and other recreational facilities and equipment*, Subcommittee SC 5, *Ice hockey equipment and facilities*.

This first edition of ISO 10256-4, together with ISO 10256-1, ISO 10256-2, ISO 10256-3, ISO 10526-5, and ISO 10256-6, cancels and replaces ISO 10256:2003, which has been technically revised.

ISO 10256 consists of the following parts, under the general title *Protective equipment for use in ice hockey*:

- *Part 1: General requirements*
- *Part 2: Head protection for skaters*
- *Part 3: Face protectors for skaters*
- *Part 4: Head and face protection for goalkeepers*
- *Part 5: Neck laceration protectors for ice hockey players*

The following parts are under preparation:

- *Part 6: Lower leg protectors for ice hockey players*

## Introduction

Ice hockey is a contact sport with intrinsic hazards. The use of protective equipment will not eliminate all injuries but is intended to substantially reduce the severity and frequency of many injuries. Participation in the sport of ice hockey by a player implies acceptance of some risk of injury. The goal is to reduce the risk.

Performance requirements were determined after consideration of the state of the art of head and face protective design and manufacture. This specification was developed to address the unique demands and hazards associated with the position of ice hockey goalkeeper.

Three types of protectors are designated. All types are subject to impact resistance and shock attenuation requirements. Types D1 and D2 protectors are subject to hockey stick blade penetration resistance requirements over their entire area of coverage. Type D3 protectors are subject to hockey puck penetration resistance requirements within the protected area of the face and hockey stick blade penetration resistance requirements over the protected area of the head. It is recommended that Type D3 protectors be used only by players 18 years of age and older.



# Protective equipment for use in ice hockey —

## Part 4: Head and face protection for goalkeepers

### 1 Scope

This part of ISO 10256 covers performance requirements for head and face protectors to be used by ice hockey goalkeepers. It is intended to be read in conjunction with ISO 10256-1, ISO 10256-2 and ISO 10256-3.

Performance requirements are established, where appropriate for the following:

- a) materials, assembly, and design;
- b) protected areas (coverage) and penetration resistance;
- c) shock absorption;
- d) puck impact resistance;
- e) retention;
- f) optical quality.

NOTE 1 The requirements of a clause take precedent over a figure.

NOTE 2 The intent of this part of ISO 10256 is to reduce the risk of injury to the head and face of ice hockey goalkeepers without compromising the form and appeal of the game.

### 2 Normative references

The following documents, in whole or in part, are normatively referenced in this document and are indispensable for its application. For dated references, only the edition cited applies. For undated references, the latest edition of the referenced document (including any amendments) applies.

ISO 10256-1:2016, *Protective equipment for use in ice hockey—Part 1: General requirements*

ISO 10256-2:2016, *Protective equipment for use in ice hockey—Part 2: Head protection for skaters*

ISO 10256-3:2016, *Protective equipment for use in ice hockey—Part 3: Face protectors for skaters*

CSA Z262.6-14, *Specifications for Facially Featured Headforms*

### 3 Terms and definitions

For the purposes of this document, the terms and definitions given in ISO 10256-1, ISO 10256-2 and ISO 10256-3 and the following apply.

#### 3.1

##### **goalkeeper head and face protector**

##### **goalkeeper protector**

device intended to protect the head and face of an ice hockey goalkeeper

Note 1 to entry: Examples can include but are not limited to the following:

## ISO 10256-4:2016(E)

- a) skater helmet in combination with a full-face protector; or
- b) mask that consists of
  - 1) a front portion to cover part of the head, face and jaw,
  - 2) a covering (e.g. cage) for the eyes and face, and
  - 3) a moveable backplate that covers the back of the goalkeeper's head.

### 3.2

#### **Type D1**

goalkeeper head and face protectors meeting the requirement for ice hockey stick blade penetration resistance within the protected areas of the head and face

### 3.3

#### **Type D2**

goalkeeper head and face protectors meeting the requirement for ice hockey stick blade penetration resistance within the protected areas of the head and face and are intended for use by goalkeepers, 10 years of age or younger

### 3.4

#### **Type D3**

goalkeeper head and face protectors meeting the requirement for ice hockey stick blade penetration resistance within the protected area of the head and puck penetration resistance within the protected area of the face

## 4 Requirements

### 4.1 General

In addition to meeting this part of ISO 10256, a goalkeeper head and face protector shall meet the requirements according to ISO 10256-2:2016, 4.1 to 4.3 throughout their full range of adjustment.

### 4.2 Design

#### 4.2.1 Padding

Padding or cushioning material shall be used to cover all hard surfaces of the protector that could otherwise come into contact with the wearer's head and shall remain in position under normal conditions of use.

#### 4.2.2 Load-bearing area

Protectors shall have a minimum padded load-bearing area as specified in ISO 10256-3:2016, Figure 5.

#### 4.2.3 Welded wire components

All wire ends shall terminate at the perimeter of the wire cage.

#### 4.2.4 Overlap

**4.2.4.1** The wire cage portion of the face protector shall overlap all edges of the head protector within the protected area (see [4.3.2](#)) by at least 6 mm.

**4.2.4.2** For a face protector/skater helmet combination, the face protector shall overlap the lower edge of the helmet (forehead area) by at least 6 mm in the horizontal plane and follow the helmet backwards at least to the mid-frontal plane down to the basic plane (see [Figure 2](#), G'H'HZZ'HH'G').



#### 4.2.5 Minimum distance (headform to face protector)

Except where it is covered by padding, no part of the protector shall be closer than 10 mm to the surface of the facially featured headform within the area of protection outside of the no-contact zone.

#### 4.2.6 Maximum distance (headform to face protector)

The horizontal distance measured on the median plane, between the inside of the face protector and points g and Sn on the facially featured headform shall not exceed 60 mm (see [Figure 1](#)).

### 4.3 Protected areas (coverage)

#### 4.3.1 Protected area of the head

The protected area of the head shall comply with ISO 10256-2:2016, 4.4.

#### 4.3.2 Protected area of the face

The protected area shall include the front portion extending to at least the line G'-H'L-HL-Z-Z-HR-H'R-G' (where L is left and R is right) in [Figure 2](#) as viewed perpendicular to the median plane and when the protector is tested according to [5.4.2](#).

### 4.4 Penetration resistance

#### 4.4.1 General

With the exception of the ear apertures (ear openings) and when tested according to [5.5](#), the following shall apply.

#### 4.4.2 Types D1 and D2

There shall be no contact with the bare headform by the test blade within the protected areas of the head and face.

#### 4.4.3 Type D3

There shall be no contact with the bare headform by the test blade within the protected area of the head and no contact by the test disk within the protected area of the face.

### 4.5 Shock-absorbing capacity

When tested according to [5.6](#), no single impact shall exceed a peak acceleration of 275 g under all test conditions. The outer covering (shell) shall remain intact, with no cracks visible through its full thickness.

### 4.6 Puck impact resistance

#### 4.6.1 Contact test

When tested according to [5.7](#),

- a) neither the protector nor the puck shall touch the facially featured headform within the no-contact zone (see ISO 10256-3:2016, Figure 3),
- b) the shock-absorbing material at the load-bearing area shall remain securely attached to the face protector, and

## ISO 10256-4:2016(E)

- c) there shall be no
  - 1) breakage of the structural components of the face protector,
  - 2) chips (cracking of surface coatings may be present),
  - 3) failure of the protector's points of attachment to the helmet, and
  - 4) cracking throughout the full thickness of the outer covering (shell) within the protected area of the face (see [4.3.2](#)).

### 4.6.2 Toughness test

When tested according to [5.7](#), there shall be no

- a) breakage of the wire,
- b) weld separations on the perimeter of the protector or at the ends of wires where they meet each other (in the case of welded wire protectors),
- c) failure of the protector's points of attachment to the helmet, and
- d) cracking throughout the thickness of the outer covering (shell) within the protected area of the face (see [4.3.2](#)).

### 4.7 Retention system

The retention system which is required on all goalkeeper protectors shall comply with ISO 10256-2:2016, 4.7 with the exception of ISO 10256-2:2016, Figure 4, which shall be substituted by [Figure 4](#) in this document.

### 4.8 Field of vision

When tested under ambient conditions, the helmet shall not interfere with vision as defined by the following angles:

- a) upward: 35°;
- b) downward: 60°;
- c) horizontally: 90°.

NOTE Several methods exist for measuring visual interference. See ISO 10256-2:2016, 5.3.

## 5 Test methods

### 5.1 General

#### 5.1.1 Tolerances and uncertainty estimations

See ISO 10256-1:2016, Clause 5.

#### 5.1.2 Samples

For a given model/size, a minimum of five new and complete goalkeeper head and face protectors and two additional face protectors as offered for sale shall be tested according to ISO 10256-2:2016, Table 1 and [Table 1](#). The protectors shall be inspected visually and by hand before conditioning. Samples shall be numbered 1, 2, 3, and so forth.

### 5.1.3 Component assemblies

A mask may be assembled from a separate head and face protector according to the manufacturer's instructions provided that the combination meets all of the requirements of this part of ISO 10256 and that the components are designed to be compatible without modification.

## 5.2 Conditioning

Conditioning of samples (i.e. goalkeeper head and face protector) shall be done according to ISO 10256-1:2016, Clause 6, ISO 10256-2:2016, Table 1 and [Table 1](#).

## 5.3 Protector positioning

The protector shall be positioned on the largest headform for its size range according to the manufacturer's instructions so that the chin portion of the protector rests on the load-bearing area of the headform (see ISO 10256-3:2016, Figure 5) and the helmet is positioned as close to the HPI as possible. The HPI shall be specified by the protector manufacturer.

Where the HPI is not available from the manufacturer, the sample shall not be tested.

## 5.4 Protected area (coverage) test

### 5.4.1 Protected area of the head

See ISO 10256-2:2016, 4.4.

### 5.4.2 Protected area of the face

#### 5.4.2.1 Headform

The facially featured headforms specified in CSA Z262.6 shall be used.

#### 5.4.2.2 Positioning

The protector shall be positioned according to [5.3](#).

### 5.4.3 Coverage test

Examine the protector to ensure that it covers the area of protection defined in [4.3.2](#).

## 5.5 Penetration test

### 5.5.1 Test apparatus

The apparatus consists of

- a) a facially featured headform according to CSA Z262.6,
- b) a steel test blade according to according to ISO 10256-2:2016, Figure 5, and
- c) a steel test disk according to [Figure 3](#).

## ISO 10256-4:2016(E)

### 5.5.2 Procedures

#### 5.5.2.1 General

Attempt to make contact with the headform by trying to enter any part of the penetrator at any angle through openings within the protector's perimeter and within the protected areas as specified in [5.5.2.2](#) and [5.5.2.3](#). Record whether contact with the bare headform surface is made.

#### 5.5.2.2 Penetration test over the protected area of the head

See ISO 10256-2:2016, 4.5.

#### 5.5.2.3 Penetration test over the protected area of the face

##### 5.5.2.3.1 Mask positioning

The protector shall be positioned according to [5.3](#).

##### 5.5.2.3.2 Penetration test for Type D1 and D2 protectors

Using the test blade, an attempt shall be made to contact the headform through all of the protector's openings within the protected area of the face as defined in [4.3.2](#) and [Figure 2](#).

##### 5.5.2.3.3 Penetration test for Type D3 protectors

Using the test disk (see [Figure 3](#)), an attempt shall be made to contact the headform through all of the protector's openings within the protected area of the face as defined in [4.3.2](#) and [Figure 2](#).

### 5.6 Shock absorbing capacity test

The shock absorbing capacity test shall be carried out according to ISO 10256-2:2016, 5.7.

If any of the prescribed impact sites cannot be reached, an attempt shall be made to reach the site by removing the face protector (cage). If the problem persists, even after the removal of the cage, the prescribed site is dropped and an alternate, non-prescribed site, on the same protector, in close proximity and within the test area, shall be determined according to in ISO 10256-2:2016, 5.7.1 and 5.7.2.

### 5.7 Puck impact resistance test

The puck impact resistance test shall be carried out according to ISO 10256-3:2016, 6.8 with the exception of any reference to ISO 10256-3:2016, Table 1. Instead, [Table 1](#) of this document shall be used.

## 6 Test report

The test report shall comply with ISO 10256-1:2016, Clause 7, ISO 10256-2:2016, Clause 6 and ISO 10256-3:2016, Clause 7.

## 7 Permanent marking

Each complete protector shall be marked permanently and legibly according to ISO 10256-2:2016, Clause 7 and ISO 10256-3:2016, Clause 8, except for the type designation. The following type designation shall be used instead: "Ice Hockey Goalkeeper Head and Face Protector".

Type D3 goalkeeper head and face protectors shall include the following statement in their warnings:

**WARNING — Type D3 protectors will not prevent a stick blade from passing through and possibly causing serious eye injuries. To reduce the risk of injury, a Type D1 protector is highly recommended.**

## 8 Information for users

Information to be provided to the users shall comply with ISO 10256-1:2016, Clause 9, ISO 10256-2:2016, Clause 8 and ISO 10256-3:2016, Clause 9.

**Table 1 — Protocol for puck impact resistance testing (Types D1, D2 and D3)**

Type	Sample no.	In combination with helmet sample # as identified in ISO 10256-2:2016, Table 1	Test	Conditioning temperature (see ISO 10256-1:2016, Clause 6)	Impact site	Puck velocity m/s	Test methods
D1 and D3	1	1	contact	ambient	eye	33 ± 1	<a href="#">5.7</a>
	2	2			mouth		
	3	3			side		
	4	4	toughness	low	eye or mouth or side	36 ± 1	
	5	5		ambient			
D2	1	1	contact	ambient	eye	25 ± 1	<a href="#">5.7</a>
	2	2			mouth		
	3	3			side		
	4	4	toughness	low	eye or mouth or side	28 ± 1	
	5	5		ambient			

Dimensions in millimetres

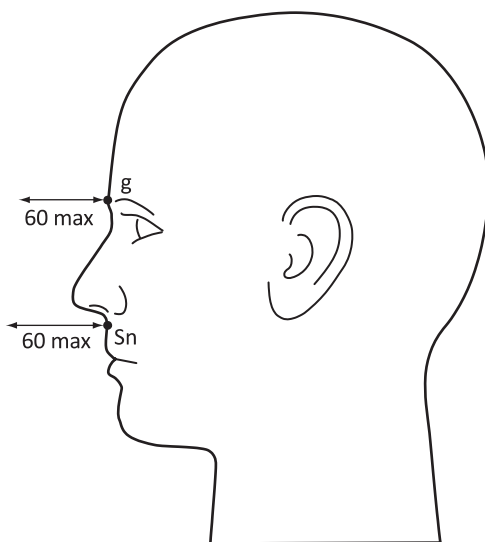
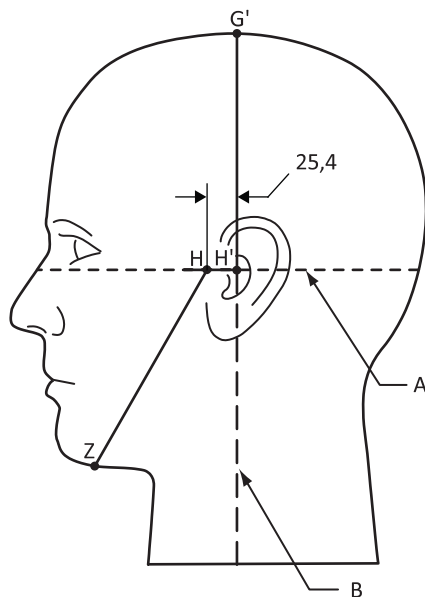

Figure 1 — Distance requirements (4.2.6)

Dimensions in millimetres



**Key**

- A basic plane
- B mid-frontal plane

Figure 2 — Minimum protected area (coverage) of the face (4.3.2)

NOTE Point Z is defined in ISO 10256-3:2016, Figure 4.

Dimensions in millimetres

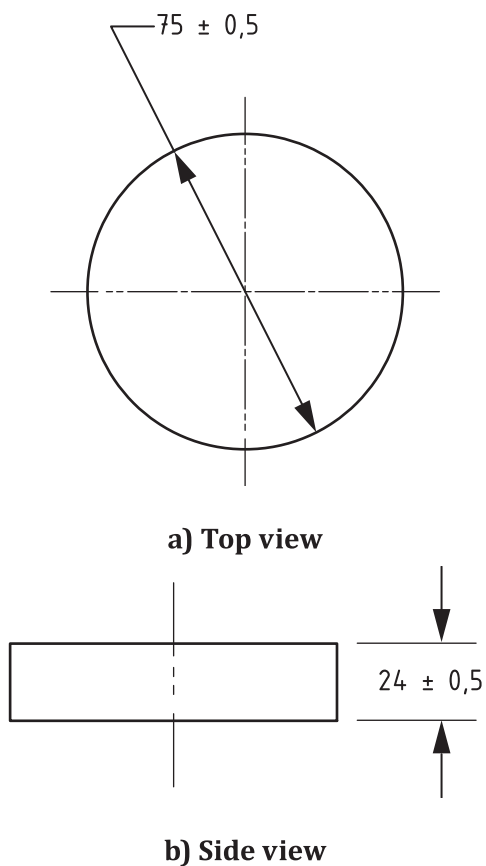
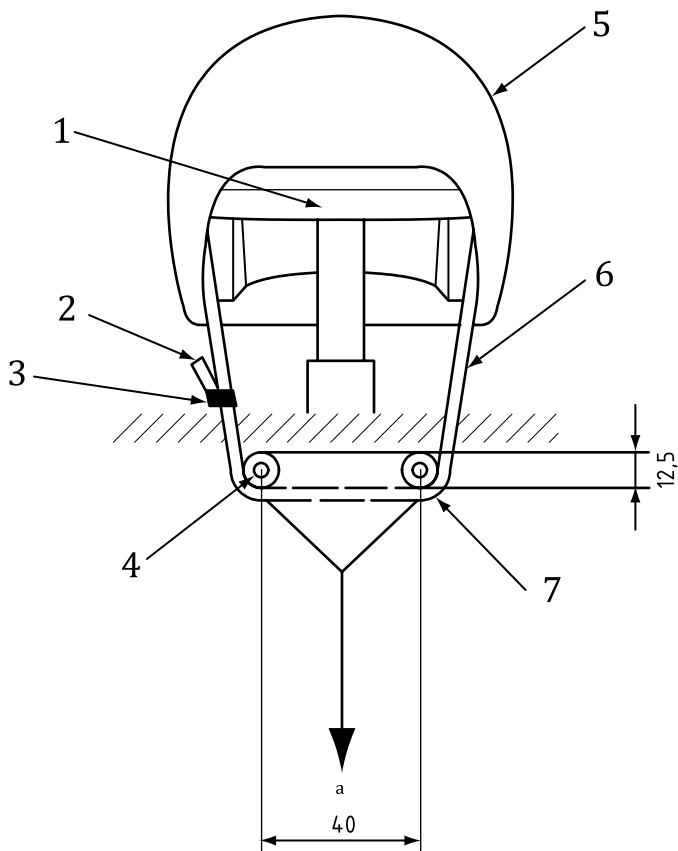

Figure 3 — Test disk (penetrator)



**Key**

- 1 headform
- 2 25 of free chin strap outside the adjustment device
- 3 adjustment device
- 4 rollers
- 5 test helmet
- 6 chin strap
- 7 length of roller 30 minimum
- a Force.

**Figure 4 — Retention system testing apparatus**





