**Protective equipment for use in ice
hockey —**

**Part 2:
Head protection for skaters**

*Équipements de protection destinés à être utilisés en hockey sur
glace —*

Partie 2: Protections de tête pour les skateurs





COPYRIGHT PROTECTED DOCUMENT

© ISO 2016, Published in Switzerland

All rights reserved. Unless otherwise specified, no part of this publication may be reproduced or utilized otherwise in any form or by any means, electronic or mechanical, including photocopying, or posting on the internet or an intranet, without prior written permission. Permission can be requested from either ISO at the address below or ISO's member body in the country of the requester.

ISO copyright office
Ch. de Blandonnet 8 • CP 401
CH-1214 Vernier, Geneva, Switzerland
Tel. +41 22 749 01 11
Fax +41 22 749 09 47
copyright@iso.org
www.iso.org

Contents

	Page
Foreword	iv
Introduction	v
1 Scope	1
2 Normative references	1
3 Terms and definitions	1
4 Requirements	4
4.1 Innocuousness.....	4
4.2 Ergonomics.....	4
4.3 Attachments.....	4
4.3.1 Optional devices.....	4
4.3.2 Fastener components.....	4
4.3.3 Eye and full-face protectors.....	4
4.4 Protected area.....	4
4.4.1 Minimum protected area.....	4
4.4.2 Ear aperture.....	4
4.4.3 Ventilation openings.....	5
4.5 Penetration.....	5
4.6 Shock absorbing capacity.....	5
4.7 Retention system.....	5
4.7.1 Straps.....	5
4.7.2 Extensibility and strength.....	5
4.8 Field of vision.....	5
5 Test methods	5
5.1 Sampling.....	5
5.2 Conditioning temperatures.....	5
5.3 Field of vision.....	6
5.4 Helmet positioning index (HPI).....	6
5.5 Protected area.....	6
5.6 Determination of penetration characteristics.....	6
5.6.1 Test apparatus.....	6
5.6.2 Procedure.....	6
5.7 Determination of shock absorbing capacity.....	7
5.7.1 Impact sites.....	7
5.7.2 Marking impact locations on headform.....	7
5.7.3 Apparatus.....	7
5.7.4 Procedure.....	7
5.8 Determination of retention system function.....	8
5.8.1 Apparatus.....	8
5.8.2 Positioning.....	8
5.8.3 Extensibility and releasing force.....	8
6 Test report	8
7 Permanent markings	8
8 Information for users	9
Annex A (normative) Impact drop test using a free-fall test apparatus with a guided carrier	15
Annex B (normative) Impact drop test using a guided monorail	19
Annex C (informative) Method for measuring field of vision	23
Bibliography	26

Foreword

ISO (the International Organization for Standardization) is a worldwide federation of national standards bodies (ISO member bodies). The work of preparing International Standards is normally carried out through ISO technical committees. Each member body interested in a subject for which a technical committee has been established has the right to be represented on that committee. International organizations, governmental and non-governmental, in liaison with ISO, also take part in the work. ISO collaborates closely with the International Electrotechnical Commission (IEC) on all matters of electrotechnical standardization.

The procedures used to develop this document and those intended for its further maintenance are described in the ISO/IEC Directives, Part 1. In particular the different approval criteria needed for the different types of ISO documents should be noted. This document was drafted in accordance with the editorial rules of the ISO/IEC Directives, Part 2 (see www.iso.org/directives).

Attention is drawn to the possibility that some of the elements of this document may be the subject of patent rights. ISO shall not be held responsible for identifying any or all such patent rights. Details of any patent rights identified during the development of the document will be in the Introduction and/or on the ISO list of patent declarations received (see www.iso.org/patents).

Any trade name used in this document is information given for the convenience of users and does not constitute an endorsement.

For an explanation on the meaning of ISO specific terms and expressions related to conformity assessment, as well as information about ISO's adherence to the World Trade Organization (WTO) principles in the Technical Barriers to Trade (TBT) see the following URL: www.iso.org/iso/foreword.html.

The committee responsible for this document is ISO/TC 83, *Sports and other recreational facilities and equipment*, Subcommittee SC 5, *Ice hockey equipment and facilities*.

This first edition of ISO 10256-2, together with ISO 10256-1, ISO 10256-3, ISO 10256-4, ISO 10256-5, and ISO 10256-6 cancels and replaces the ISO 10256:2003, which has been technically revised.

ISO 10256 consists of the following parts, under the general title *Protective equipment for use in ice hockey*:

- *Part 1: General requirements*
- *Part 2: Head protection for skaters*
- *Part 3: Face protectors for skaters*
- *Part 4: Head and face protection for goalkeepers*
- *Part 5: Neck laceration protection for ice hockey players*

The following parts are under preparation:

- *Part 6: Lower leg protectors for ice hockey players*

Introduction

Ice hockey is a sport in which there is a risk of injury. Ice hockey helmets afford no protection from neck or spinal injury. Severe head, brain, or spinal injuries, including paralysis or death, can occur in spite of using an ice hockey helmet according to this part of ISO 10256.

The intention of head protection used in ice hockey is to reduce the frequency and severity of localized injuries to the head. The protective function is such that the force from impacts against the protector is distributed and dampened and the penetration of objects is counteracted.

Part of the head protection for use in ice hockey consists of a helmet. To achieve the performance of which it is capable and to ensure stability on the head, a helmet is intended to be as closely fitting as possible consistent with comfort. In use, it is essential that the helmet is securely fastened, with any chin strap or neck strap adjusted according to manufacturer's instructions.

Subcommittee 5 is aware that specifications for the performance of the helmet are required to reduce the risk of injury in ice hockey. There was consensus that most of today's head protectors meet the performance requirements of this part of ISO 10256. The goal of the subcommittee is to promote the use of better materials and/or constructions as they become available to meet the future requirements of the sport of ice hockey. Subcommittee 5 recognizes that in order to provide for comfort, fit and use, helmets is intended to have a mass consistent with providing the appropriate performance characteristics.

Protective equipment for use in ice hockey —

Part 2: Head protection for skaters

1 Scope

This part of ISO 10256 specifies performance requirements and test methods for head protectors for use in ice hockey and is intended to be read in conjunction with ISO 10256-1.

Requirements and the corresponding test methods, where appropriate, are given for the following:

- a) construction and protected area;
- b) shock absorption;
- c) penetration;
- d) retention system properties;
- e) field of vision;
- f) marking and information.

This part of ISO 10256 applies to head protectors worn by

- players other than goalkeepers, and
- certain functionaries (e.g. referees).

NOTE 1 The requirements of a Clause take precedent over a figure.

NOTE 2 The intent of this part of ISO 10256 is to reduce the risk of injury to the head without compromising the form or appeal of the game.

2 Normative references

The following documents, in whole or in part, are normatively referenced in this document and are indispensable for its application. For dated references, only the edition cited applies. For undated references, the latest edition of the referenced document (including any amendments) applies.

ISO 6487, *Road vehicles — Measurement techniques in impact tests — Instrumentation*

ISO 10256-1:2016, *Protective equipment for use in ice hockey — Part 1: General requirements*

EN 960:2006, *Headforms for use in the testing of protective helmets*

3 Terms and definitions

For the purposes of this document, the terms and definitions given in ISO 10256-1 and the following apply.

3.1

drop height

vertical distance between the lowest point (impact point) of the elevated helmet and the impact surface on a drop test apparatus

3.2

fastening system

devices used to connect the components of the helmet

3.3

field of vision

extent of vision through the protector in the “as worn” position when placed on the appropriate headform and measured with reference to the entrance pupil of the stationary eye

3.4

goniometer

positioning device that moves the headform such that the angular rotation and movement in reference to the corneal eye point in both the horizontal and vertical directions can be recorded

3.5

helmet

device worn on the head that is intended to reduce the risk of head injury to ice hockey participants

Note 1 to entry: Helmets can include:

- a) a shock-attenuating system;
- b) a retention system;
- c) manufacturers' attachments.

3.6

helmet model

category of helmets that have the same essential characteristics

Note 1 to entry: Essential characteristics include:

- a) materials;
- b) dimensions;
- c) construction;
- d) retention system;
- e) protective padding.

3.7

helmet positioning index

HPI

vertical distance measured at the median plane, from the front edge of the helmet to the reference plane, when the helmet is placed on the reference headform

3.8

impact sites

Note 1 to entry: Impact sites are defined in relation to the headform using projected measurements.

3.8.1

prescribed impact site

crown, front, front boss, side, rear, rear boss

Note 1 to entry: See [Figure 1](#).

3.8.1.1

crown

point where the central vertical axis meets the top of the headform

3.8.1.2**front**

point on the median plane which is 50 mm above the anterior intersection with the reference plane

3.8.1.3**front boss**

point 25 mm above the reference plane and 45° in a clockwise or counter-clockwise direction about the central vertical axis

3.8.1.4**side**

point 25 mm above the reference plane on the mid-frontal plane

3.8.1.5**rear**

point at the posterior intersection of the median and reference plane

3.8.1.6**rear boss**

point on the reference plane and 135° in a clockwise or counter-clockwise direction about the central vertical axis

3.8.2**non-prescribed impact sites**

locations on or above the test line and at least one-fifth of the circumference of the headform from any prior impact site use

3.9**liner**

material inside the outer covering of the helmet, with the principal objective to absorb kinetic energy generated by an impact to the head

Note 1 to entry: This material, or part of it, helps to ensure a snug comfortable fit of the helmet on the head.

3.10**natural frequency**

frequency at which a system will tend to oscillate when displaced from its static equilibrium position

3.11**outer covering****shell**

material that gives the helmet its form

3.12**retention system**

system which secures the helmet firmly to the head by passing under the mandible in whole or in part when adjusted according to manufacturer's instructions

3.13**support assembly**

drop assembly in the monorail system minus the weight of the headform, ball arm, ball clamp, ball clamp bolts, and accelerometer

3.14**spherical impactor**

device made of low resonance material that couples mechanically with the ball arm connector of the drop assembly in place of the impact test headform and is used for system verification of the drop assembly

EXAMPLE Magnesium, aluminium alloy, or stainless steel.

3.15

test area

area on and above the test line, where an impact site shall be located

3.16

test line

line that defines the boundaries of the test area

Note 1 to entry: See [Figure 2](#).

4 Requirements

4.1 Innocuousness

The manufacturer shall provide written documentation indicating that the materials used in the construction of the helmet fulfil the requirements for innocuousness given in ISO 10256-1.

4.2 Ergonomics

Manufacturers shall provide documentation indicating that the helmet fulfils the requirements for ergonomics given in ISO 10256-1.

4.3 Attachments

4.3.1 Optional devices

Manufacturers shall provide documentation to confirm that any optional device fitted to the helmet has been designed to minimize the risk of injury to the wearer or other players during contact or otherwise.

4.3.2 Fastener components

Fasteners for securing attachments to the helmet shall be so designed that the degree of protection afforded to the wearer by the helmet is not thereby reduced.

4.3.3 Eye and full-face protectors

Helmets shall be designed to allow eye or full-face protectors to be attached with simple tools (e.g. screwdriver).

4.4 Protected area

4.4.1 Minimum protected area

The protected area shall be at least the area above the line BCDEF in [Figure 3](#) when the helmet is positioned according to [5.4](#). This area shall correspond with the headform size with which the helmet is to be tested.

4.4.2 Ear aperture

No ear aperture (opening) shall have a linear dimension exceeding 38 mm. The distance to any other edge of the helmet shall be not less than 20 mm. The ear aperture shall be completely surrounded by the outer covering of the helmet (shell).

4.4.3 Ventilation openings

Openings for the purpose of ventilation are permitted on the helmet provided that they fulfil the penetration requirements in [4.5](#).

4.5 Penetration

Except for the ear apertures and when tested according to [5.6](#), there shall be no contact with the bare headform by the test blade within the designated protected area.

NOTE See [Figure 5](#).

4.6 Shock absorbing capacity

When tested according to [5.7](#), no single impact shall exceed a peak acceleration of 275 *g* under all test conditions. The outer covering (shell) shall remain intact, with no cracks visible through the thickness of the shell.

4.7 Retention system

4.7.1 Straps

The retention system, which is required on all helmets, consists of a straps which passes under the mandible and is buckled on both sides of the helmet. The retention strap shall be not less than 13 mm wide.

NOTE See [Figure 4](#).

4.7.2 Extensibility and strength

When tested according to [5.8](#), the displacement of the roller holder shall not exceed 25 mm during the load range between 5 N and 110 N and the release force shall be not less than 110 N and not more than 300 N.

NOTE See [Figure 4](#).

4.8 Field of vision

When tested under ambient conditions, the helmet shall not interfere with vision in the upward and horizontal directions respective to each corneal eye point as defined by the following angles:

- a) upward: 35°;
- b) horizontally: 90°.

5 Test methods

5.1 Sampling

Only new and complete helmets as offered for sale shall be tested. The minimum number of samples needed for a complete test is found in [Table 1](#).

5.2 Conditioning temperatures

Helmet samples shall be conditioned under ambient, low and elevated temperature conditions according to ISO 10256-1.

5.3 Field of vision

The upward field of vision is the solid angle bounded by the reference plane of the headform and a second plane tilted 35° upwards from the reference plane. This second plane intersects the reference plane at two points on the front surface of the headform that are 31 mm to the right and left of the median plane.

The left horizontal field of vision is the solid angle bounded by a plane parallel and 31 mm to the left of the median plane of the headform and a second plane perpendicular to the median plane (i.e. rotated 90° horizontally) and parallel to the lateral plane. The two planes intersect with the reference plane at the front surface of the headform at a point located 31 mm to the left of the median plane.

The right horizontal field of vision is the solid angle bounded by a plane parallel and 31 mm to the right of the median plane of the headform and a second plane perpendicular to the median plane (i.e. rotated 90° horizontally) and parallel to the lateral plane. The two planes intersect with the reference plane at the front surface of the headform at a point located 31 mm to the right of the median plane.

The accuracy of the device used to measure field of vision shall be ($\pm 1^\circ$). The reference test method of determining field of vision for this part of ISO 10256 is shown in [Annex C](#).

5.4 Helmet positioning index (HPI)

The HPI and corresponding helmet size shall be provided by the helmet manufacturer. The testing laboratory shall select the headform that is appropriate to the size range. Where the HPI and corresponding helmet size range are not available from the manufacturer, the helmet shall not be tested.

5.5 Protected area

Position the helmet on the largest full headform for the helmet's size range using the helmet positioning index (HPI). Apply a load of 50 N to the crown of the helmet in order to seat the helmet to the headform. When viewed perpendicular to the median plane, the helmet shall cover the protected area as required in [4.4](#) and [Figure 3](#).

5.6 Determination of penetration characteristics

5.6.1 Test apparatus

The apparatus shall consist of:

- a) a headform according to EN 960;
- b) a steel test blade according to [Figure 5](#).

5.6.2 Procedure

5.6.2.1 Helmet positioning

The helmet shall be positioned on the largest headform for its size range, using the HPI.

5.6.2.2 Penetration test

Attempt to pass the end of the test-blade, without force, through all openings of the helmet (except the ear apertures) within the protected area (see [Figure 3](#)).

Any contact with the bare headform surface shall be recorded.

5.7 Determination of shock absorbing capacity

5.7.1 Impact sites

Impact sites shall be the six prescribed sites (see [3.8.1](#) and [Figure 1](#)) and two non-prescribed sites (see [3.8.2](#)). The impact direction shall be perpendicular to the headform surface at all impact sites.

Each of the two non-prescribed impacts shall be located on the headform on or above the test line. Each of these two non-prescribed impact sites shall be at least one-fifth of the circumference of the headform from any prior impact location on that helmet. The headform shall be positioned so that the impact location is the first point of contact with the anvil. The helmet shall then be positioned on the headform as specified by the manufacturer's HPI.

The resulting two non-prescribed impacts shall be identified by

- a) the arc distance along the reference plane from the anterior intersection of the median and reference planes (either clockwise or counter-clockwise), and
- b) the perpendicular arc distance above or below that point on the reference plane.

5.7.2 Marking impact locations on headform

Draw test line A-B-C-D-E-F on the headform as indicated in [Figure 2](#).

Determine and mark an impact site on the headform. Place the helmet on the headform as specified by the manufacturer's HPI and mark the corresponding impact location on the helmet before performing the impact test.

Alternatively, the impact site may be determined and marked first on the helmet and then marked on the headform. If marking the helmet first, make sure the corresponding mark on the headform is on or above the test line.

5.7.3 Apparatus

The impact tests shall be performed as described in [Annex A](#) or [Annex B](#).

5.7.4 Procedure

5.7.4.1 General

Conduct testing according to [Table 1](#) and [5.7.4.2](#) to [5.7.4.6](#).

5.7.4.2 Time interval between impacts

Under all test conditions, subject each impact site according to [Table 1](#) with a time interval of not less than 30 s and not more than 90 s between each impact.

5.7.4.3 Velocity measurement

At a distance not exceeding 30 mm prior to impact, the drop velocity of the headform shall be measured with an accuracy of $\pm 2\%$.

5.7.4.4 Data recording

Record the measured and calculated results (g_{\max}) in tabular form complete with time/acceleration diagrams and coordinates of the non-prescribed impact sites.

5.7.4.5 Damage

Record the damage of significance as a result of the impact test.

5.7.4.6 Reserves

Helmet 5 is a reserve helmet and should be used only if helmets 1 to 4 are damaged to the extent that further testing on them are not possible.

5.8 Determination of retention system function

5.8.1 Apparatus

The test apparatus shall consist of

- a) a three quarter headform according to EN 960, and
- b) rollers according to [Figure 4](#).

5.8.2 Positioning

Take one ambient conditioned helmet that has just undergone the shock absorbing test and position the helmet on the largest three-quarter headform for the helmet's size range using the HPI. Adjust the chin and/or neck strap so that there is a minimum of 25 mm of free strap outside the adjusting devices (see [Figure 4](#)).

5.8.3 Extensibility and releasing force

Extensibility shall be determined as follows:

- a) Place the retention strap around a set of two rollers as shown in [Figure 4](#).
- b) Apply a pretension of 5 N in the same direction as the central vertical axis.
- c) Record the vertical position of the roller holder to the nearest 1 mm.
- d) Displace the rollers at a rate of 100 mm/min up to a load of 110 N, and then record the vertical position of the roller holder.
- e) To determine the amount of extensibility, subtract the measurement specified in item c) from the measurement specified in item d) (see [4.7.2](#)).
- f) To check the releasing force of the fastening device, continue to displace the rollers until the device releases, up to a maximum of 300 N. Record the releasing force.

6 Test report

In addition to the requirements of ISO 10256-1, the test report shall include the following information:

- a) impact test method used;
- b) coordinates of the non-prescribed impact sites.

7 Permanent markings

In addition to the requirements of ISO 10256-1, helmets shall have the following markings:

- a) the size or size range of the helmet, quoted as the circumference (in centimetres) of the head which the helmet is intended to fit;

- b) the designation “ice hockey helmet”;
- c) a permanent warning in a contrasting colour to the exterior of the helmet informing the user of the limits of protection afforded by the helmet. The warning shall contain at minimum the following information:

Ice hockey is a sport in which there is a risk of injury. Helmets meeting the requirements of this part of ISO 10256 afford no protection from neck or spinal injuries. Severe head, brain, or spinal injuries, including paralysis or death, can occur in spite of using a helmet certified to this part of ISO 10256.

NOTE The precise wording of the warning is at the discretion of the party submitting the helmet for testing.

8 Information for users

In addition to the requirements of ISO 10256-1, the following information shall be provided for users:

- a) a helmet does not afford any protection from neck or spinal injuries;
- b) the use of cleaning agents, paints, or decals shall not be applied unless authorized by the manufacturer.

Table 1 — Protocol for testing head protection

Sample number (for each model size)	Conditioning	Impact site (see Figure 1)	Impacts per site	Drop velocity m/s
1	Ambient temperature (see ISO 10256-1:2016, 6.1)	All prescribed locations in any sequence. See Figure 1 and 3.8.1 .	3	4,5 ± 2 % (for all samples) 4,5 ± 0,09
2	Ambient temperature (see ISO 10256-1:2016, 6.1)	Non-prescribed 1. Non-Prescribed 2. On or above the test line shown in Figure 2 and defined in 3.8.2 .	3	
3	Low temperature (see ISO 10256-1:2016, 7.2)	Impact the helmet three times at the site which yields the highest peak acceleration or GSI under ambient temperature conditions.	3	
4	Elevated temperature (see ISO 10256-1:2016, 6.3)	Impact the helmet twice at the site which yields the highest peak acceleration or GSI under ambient temperature conditions.	2	
5	Reserve helmet ^a			

^a Helmet 5 is a reserve helmet and should be used only if helmets 1 to 4 are damaged to the extent that further testing on them are not possible.

Dimensions in millimetres

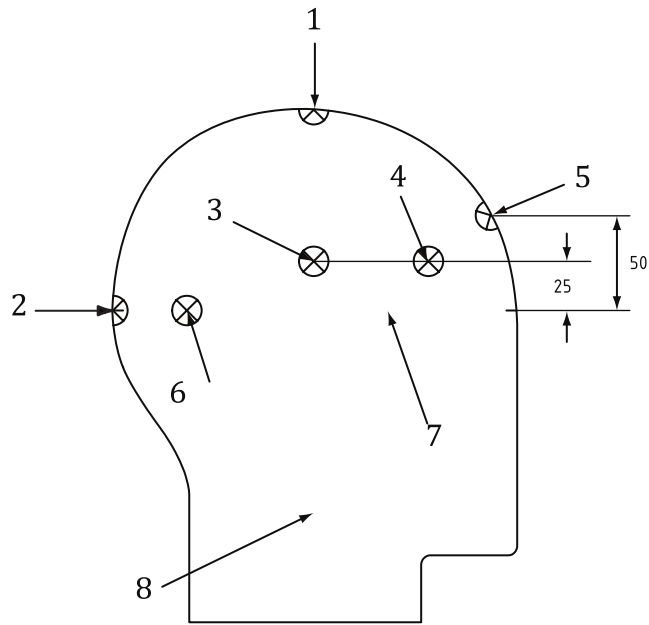

a) Side view

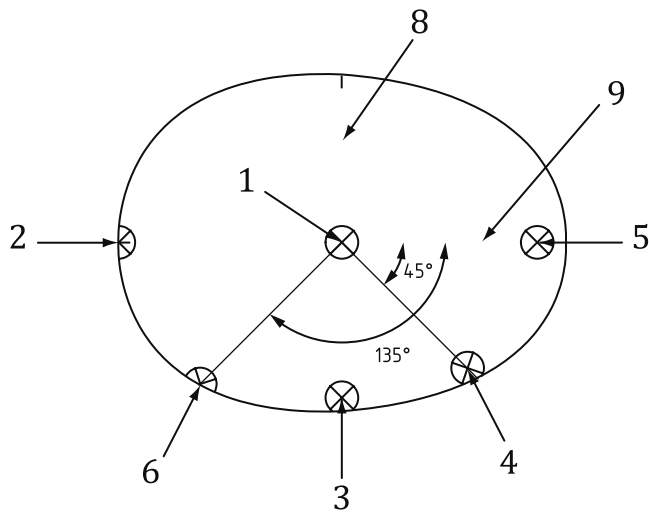

b) Top view

Key

- | | |
|--------------|---------------------|
| 1 crown | 6 rear boss |
| 2 rear | 7 reference plane |
| 3 side | 8 mid-frontal plane |
| 4 front boss | 9 median plane |
| 5 front | |

Figure 1 — Prescribed impact sites

NOTE Arrows are simply location arrows and are not intended to be impact direction arrows.

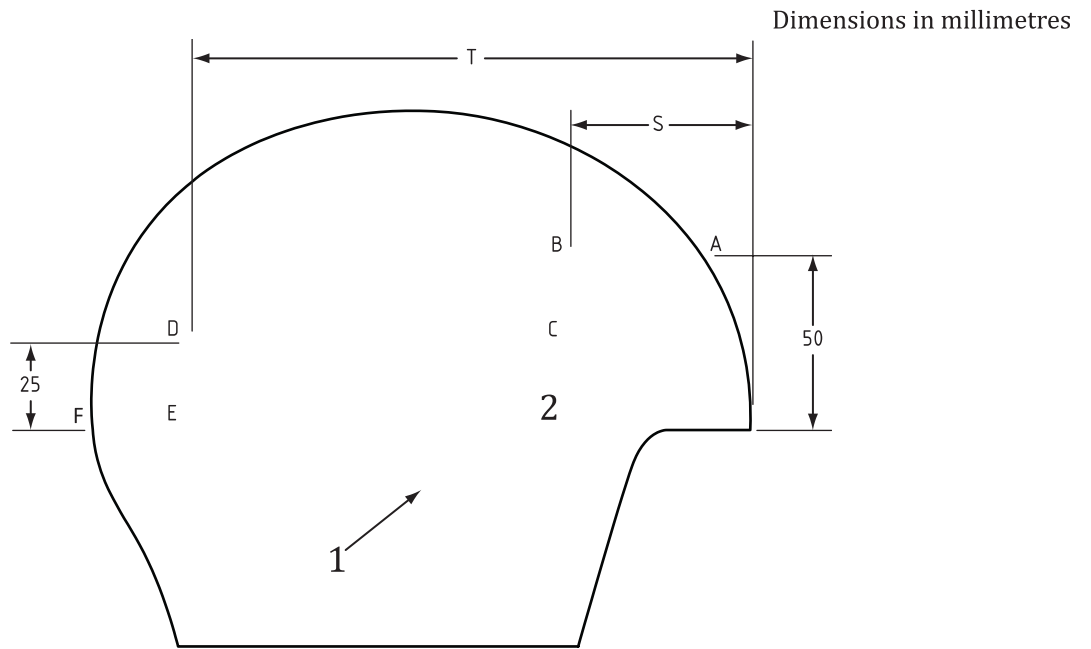

Key

- 1 mid-frontal plane
- 2 reference plane

Headform circumference mm	Dimensions mm	
	S	T
495	19,5	137,0
535	20,5	146,5
575	20,5	155,0
605	23,5	161,0

Figure 2 — Test line for non-prescribed impact sites

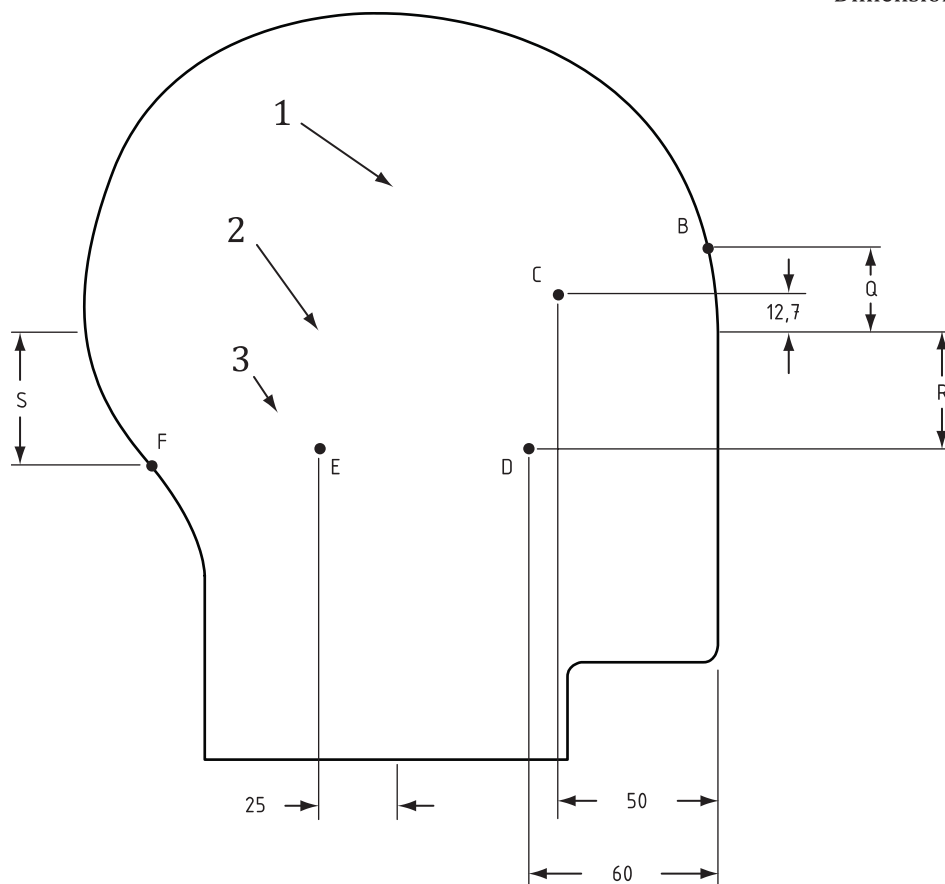

Key

- 1 mid-frontal plane
- 2 reference plane
- 3 basic plane

Headform circumference mm	Q mm	R mm	S mm
495	24	33,3	42,3
535	26	32	44
575	27	27,5	42,5
605	28	25	44

Figure 3 — Protected area

Dimensions in millimetres

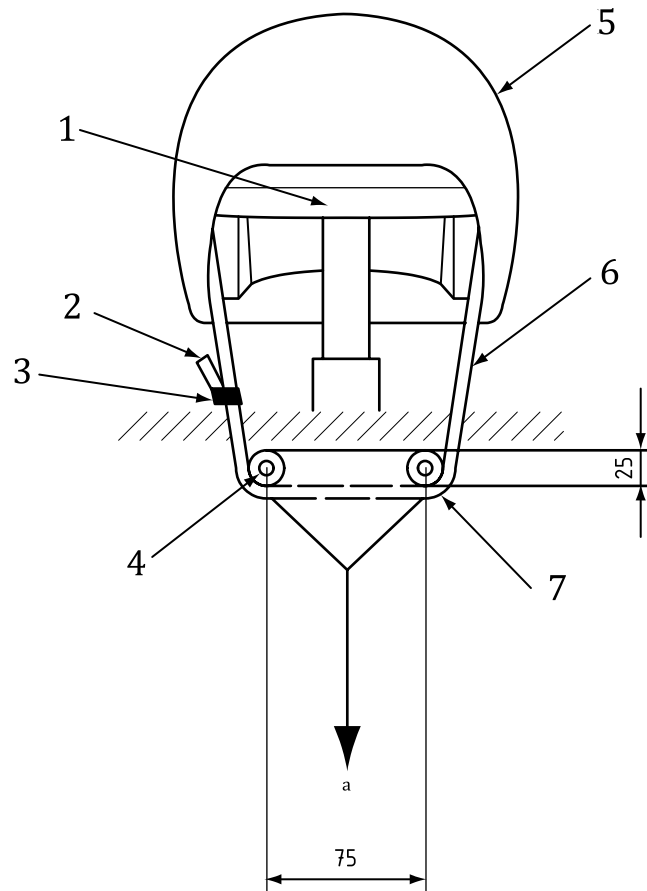

Key

- 1 headform
- 2 25 of free chin strap outside the adjustment device
- 3 adjustment device
- 4 rollers
- 5 test helmet
- 6 chin strap
- 7 length of roller 30 minimum
- a Force.

Figure 4 — Retention system testing apparatus

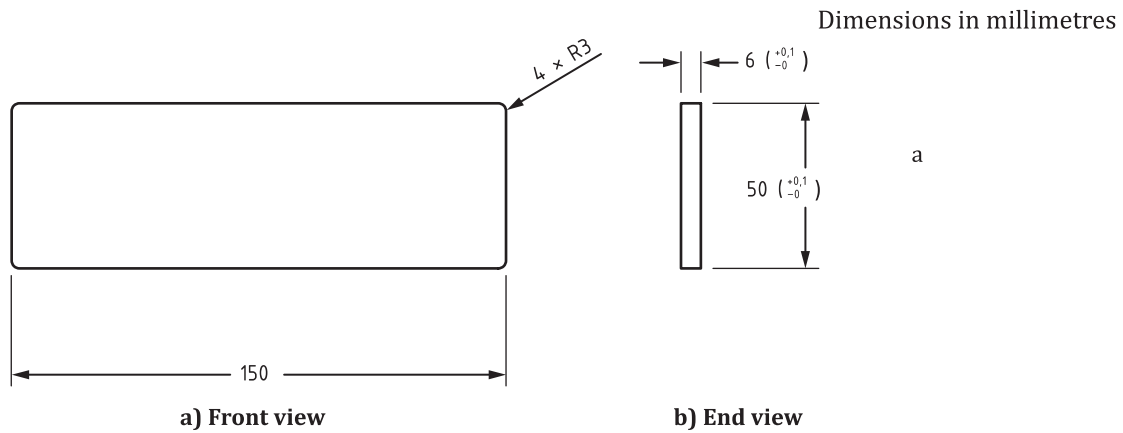

Key

- a Remove all sharp edges.

Figure 5 — Test blade (penetrator)

Annex A (normative)

Impact drop test using a free-fall test apparatus with a guided carrier

A.1 Test apparatus

A.1.1 Description

A.1.1.1 The test apparatus shall comprise:

- a) an impact surface fixed to a base;
- b) a guided mobile system supporting the free falling helmeted headform;
- c) a guidance system for the mobile system;
- d) a headform fitted with a triaxial accelerometer and a velocity measuring assembly;
- e) a system by which the point of impact can be brought into correspondence with the centre of the impact anvil.

A.1.1.2 An example of the test apparatus is shown in [Figure A.1](#).

A.1.2 Base

The base shall be solid and made of steel or a combination of steel and concrete and have a mass of not less than 500 kg. At least the uppermost 25 mm shall consist of steel and be firmly attached to the concrete.

No part of the base shall have a resonance frequency liable to affect the measurement.

A.1.3 Impact surface

The impact surface shall be a flat modular elastomer programmer (MEP) 130 mm in diameter and 25 mm in thickness which is firmly fixed to the top surface of a flat anvil. The MEP required is a 60 ± 5 Durometer Shore A Hardness impact surface. The top surface of the base may be used as the flat metal anvil if it is faced with a steel plate with minimum thickness of 25 mm and a minimum top surface area of 0,09 m².

A.1.4 Mobile system and guides

The mobile system supporting the headform shall be such that its characteristics do not affect the measurement of acceleration at the centre of gravity of the headform. It shall also be such that any impact site (see [5.4](#)) can be positioned vertically (within 5°) above the centre of the anvil.

A.1.5 Accelerometer and measuring system

A.1.5.1 The triaxial accelerometer is mounted at the centre of gravity of the headform. The transducer shall be capable of measuring and recording accelerations up to 1 000 *g*. The maximum total mass of the triaxial accelerometer and the transducer shall be 50 g.

A.1.5.2 The measuring system shall include equipment to record the velocity of the headform.

A.1.6 System accuracy

The impact recording system shall be capable of measuring shocks of up to 1 000 *g* peak acceleration with a limit of error of $\pm 5\%$ and over a frequency range of 5 Hz to 900 Hz. Natural frequencies of a particular headform type, up to and including the third harmonic, should be recorded. Means or methods for determining and recording the magnitude of the (resultant) acceleration vector (*g*), the Gadd Severity Index (GSI) and impact velocity shall be available. A permanent hard copy record of any particular impact (acceleration–time curve) shall be available.

A.1.7 Signal conditioning

An ISO 6487 CFC 1000 low pass filter shall be used in conditioning the accelerometer signal. If a computer is employed as a read-out device, a minimum sampling rate of 10 000 samples per second shall be used for each channel of the accelerometer signal.

A.1.8 Impact measurement parameters

Shock absorption capabilities, as measured by a triaxial accelerometer, shall be determined by the resultant peak linear acceleration.

A.1.9 Headforms

A three quarters metal headform, capable of accepting an accelerometer mounted at its centre of gravity and conforming to the requirements of EN 960 shall be used for impact testing. See EN 960:2006, Table 1.

Table A.1 — Size and associated mass of headform

Size mm	Mass kg
495	3,1 ± 0,10
535	4,1 ± 0,12
575	4,7 ± 0,14
605	5,6 ± 0,16

A.2 System verification

A.2.1 Method

A.2.1.1 The system instrumentation shall be checked before and after each series of tests by dropping the spherical impactor onto a MEP at an impact velocity of $(3,96 \pm 0,08)$ m/s. The resultant peak linear acceleration obtained during this impact should be as specified by the MEP supplier.

A.2.1.2 Three such impacts shall be performed in each of three directions at intervals of $75 \text{ s} \pm 15 \text{ s}$, before and after each series of tests.

A.2.1.3 If the mean peak acceleration obtained in the pre-test impacts differs by more than 5% from the mean peak acceleration obtained in the post-test impacts, recalibration of the instruments and transducers is required, and all data obtained during that series of impact tests should be discarded.

A.2.2 Spherical impactor

The spherical impactor shall

- a) be made of a low frequency response material (magnesium),
- b) have striking surfaces of (73 ± 1) mm radius, and
- c) have a mass of $(4,00 \pm 0,02)$ kg including the accelerometer.

The centre of gravity shall coincide with the geometrical centre of the sphere within ± 1 mm and the accelerometer shall coincide with the geometrical centre within ± 10 mm.

A.2.3 Modular elastomer programmer (MEP)

A cylindrical-shaped pad used as an impact surface for the spherical impactor. The MEP is 130 mm in diameter and 25 mm thick. It is affixed to the top surface of a flat, 6 mm thick aluminium plate. The durometer of the MEP is (60 ± 5) Shore A and shall include a calibration number provided by the supplier.

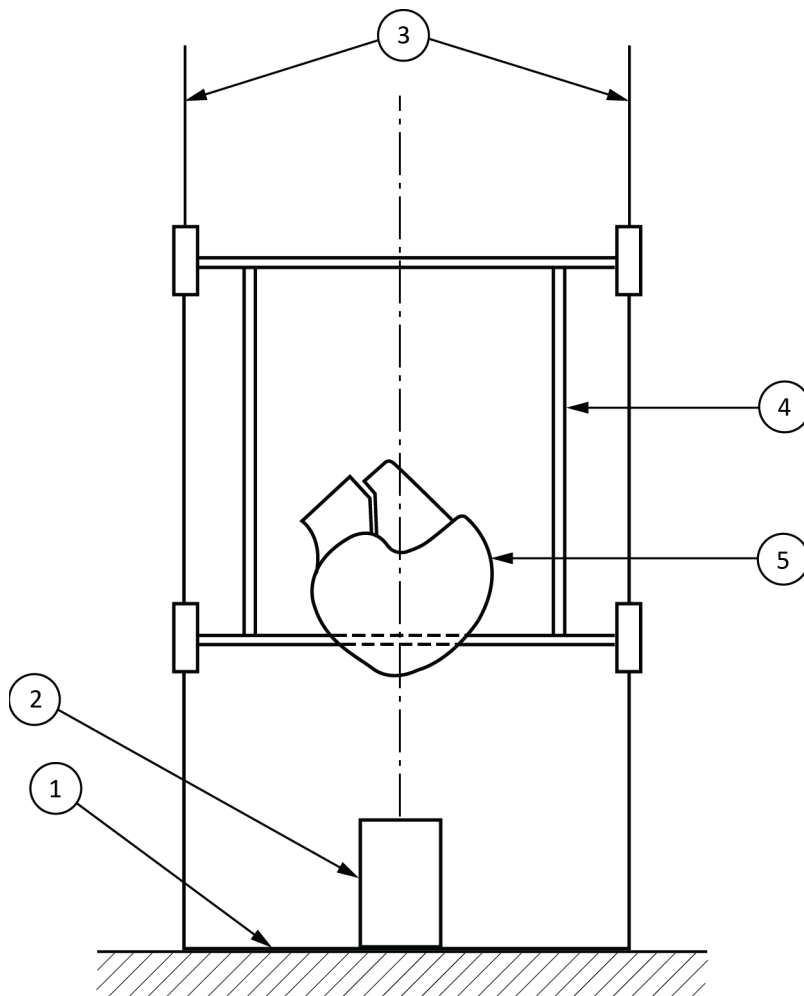

Key

- 1 steel base
- 2 anvil
- 3 guides
- 4 support dolly
- 5 headform with helmet

Figure A.1 — Free fall helmet drop test rig

Annex B (normative)

Impact drop test using a guided monorail

B.1 Apparatus

The test apparatus shall comprise:

- a) a sectioned EN 960 magnesium headform fitted with a uniaxial accelerometer;
- b) an anvil rigidly fixed to a base and an impact surface fixed to the base;
- c) a monorail guidance system with an adjustable mounting for the helmeted headform to permit impacts to be delivered to any location on the helmet above the test line;
- d) a system for acquiring and recording the test data.

B.2 Impact base and impact surface

B.2.1 The impact base shall be firmly attached to a concrete floor, and shall consist of a rigid steel slab with a mass of at least 136 kg with a minimum thickness of 50 mm.

B.2.2 The impact surface for system verification (see [B.6](#)) and for testing shall be a flat modular elastomer programmer (MEP pad) 152 mm in diameter and 25 mm in thickness which is firmly fixed to the top surface of a flat anvil. The MEP pad required is a 60 ± 5 Durometer Shore A Hardness impact surface. The top surface of the base may be used as the flat metal anvil, if it is faced with a steel plate with minimum thickness of 25 mm and a minimum top surface area of 0,09 m².

B.3 Headform carriage assembly

The system supporting the headform shall be such that its characteristics do not affect the measurement of acceleration at the centre of gravity of the headform. It shall also be such that any impact site can be positioned vertically above the centre of the anvil.

B.4 Headforms

A full metal headform, capable of accepting an accelerometer mounted at its centre of gravity and conforming to the requirements of EN 960, shall be used. See EN 960:2006, Table 1. The headform shall have no natural resonant frequencies below 3 000 Hz. The headform and supporting assembly shall have a combined mass as described in [Table B.1](#), with the supporting assembly contributing to no more than 50 % of the total.

Table B.1 — Size and associated mass of headform

Size mm	Mass kg
495	3,1 ± 0,10
535	4,1 ± 0,12
575	4,7 ± 0,14
605	5,6 ± 0,16

B.5 Instrumentation

A device capable of providing a gravity assisted guided drop shall be used. The device shall include an adjustable mounting system that allows impacts to be delivered to any location on the helmet above the test line (see [Figure B.1](#)).

A uniaxial accelerometer shall be mounted at the centre of gravity of the test headform. The transducer shall be capable of withstanding a shock of 1 000 *g* without damage.

Natural frequencies of a particular headform type, up to and including the third harmonic, should be recorded. Means for determining and recording the magnitude of the (resultant) acceleration vector (*a* in *g* units), the Gadd Severity Index and impact velocity shall be available. A permanent hard copy record (acceleration time curve) of any particular trial shall be attached to any written report.

B.6 System verification

B.6.1 Performance of the data acquisition system shall be checked before the start and upon completion of all impact tests that use a spherical impactor, under a guided or free fall, to strike an MEP pad attached to the anvil.

B.6.2 The weight of the drop assembly (i.e. the combined weight of the instrumented spherical impactor and support assembly) shall be 5,0 kg ± 0,1 kg. The spherical impactor shall

- a) be capable of holding an accelerometer at its centre of mass,
- b) be made of a low-frequency response material (e.g. magnesium), and
- c) have a striking surface radius of 73 ± 1 mm.

B.6.3 The MEP pad shall

- a) have a diameter of 150 ± 2 mm,
- b) have a thickness of 25 ± 0,5 mm,
- c) have a Shore Type A durometer hardness of 60 ± 5, and
- d) be affixed to an aluminium plate with the thickness of 6 mm.

The spherical impactor shall strike the centre of the pad with a velocity of (5,2 ± 0,01) m/s, measured over the last 40 mm of fall.

B.6.4 Six impacts, at intervals of 75 s ± 15 s, shall be performed before and after the testing program. The first three impacts shall be used to warm up the pad; the peak acceleration of the remaining three impacts shall be recorded. The mean of the three post-test results shall not differ by more than 5% from the mean of the three pre-test results. Where the difference is greater than 5%, the results shall be discarded and the source of the difference shall be identified and corrected. The tests shall then be repeated with new samples.

B.6.5 The system check shall not preclude the need to calibrate the data acquisition system and the instrumentation to national standards at an interval determined appropriate by the laboratory.

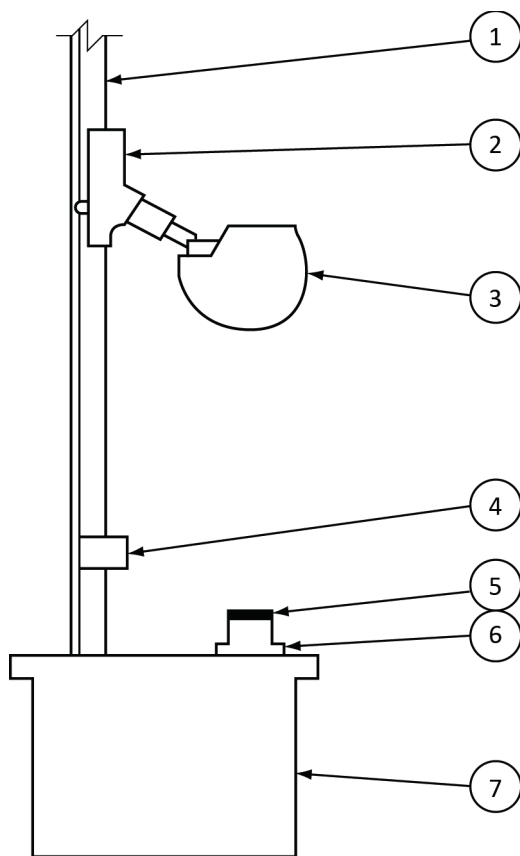

Key

- 1 monorail
- 2 follower mechanism
- 3 headform
- 4 velocity sensor
- 5 MEP pad
- 6 anvil
- 7 base

Figure B.1 — Monorail helmet drop testing rig

Annex C (informative)

Method for measuring field of vision

C.1 Test apparatus

The peripheral field of vision of head protectors is measured with the test apparatus shown in [Figure C.1](#).

C.2 Procedure

C.2.1 Mark points L_1 , L_2 , K_1 and K_2 on the headform according to [Figure 3](#). Attach the headform to the base plate so that the vertical line y-y through the pivoting point A coincides with point K_1 and the horizontal line x-x through the pivoting point B coincides with both points K_1 and K_2 .

C.2.2 The horizontally pivoting arm (3) of [Figure C.1](#) shall be parallel with the line x-x. The beam of light shall fall upon point K_1 , forming a right angle with the line y-y.

Measure the horizontal field of vision by turning the horizontally pivoting arm (3) until the light beam is blocked out by the head protector. Measure and record the turning angle.

C.2.3 Measure the vertical field of vision downwards by setting the horizontally pivoting arm (3) in the zero position and then turning the vertically pivoting arm (4) of [Figure C.1](#) downwards until the light beam is blocked out by the head protector. Measure and record the turning angle from the starting position 0° .

C.2.4 The above description applies to the downwards vision of the left eye and the horizontal vision from point K_1 . The vision upwards and horizontally from the other points is measured in a similar way.

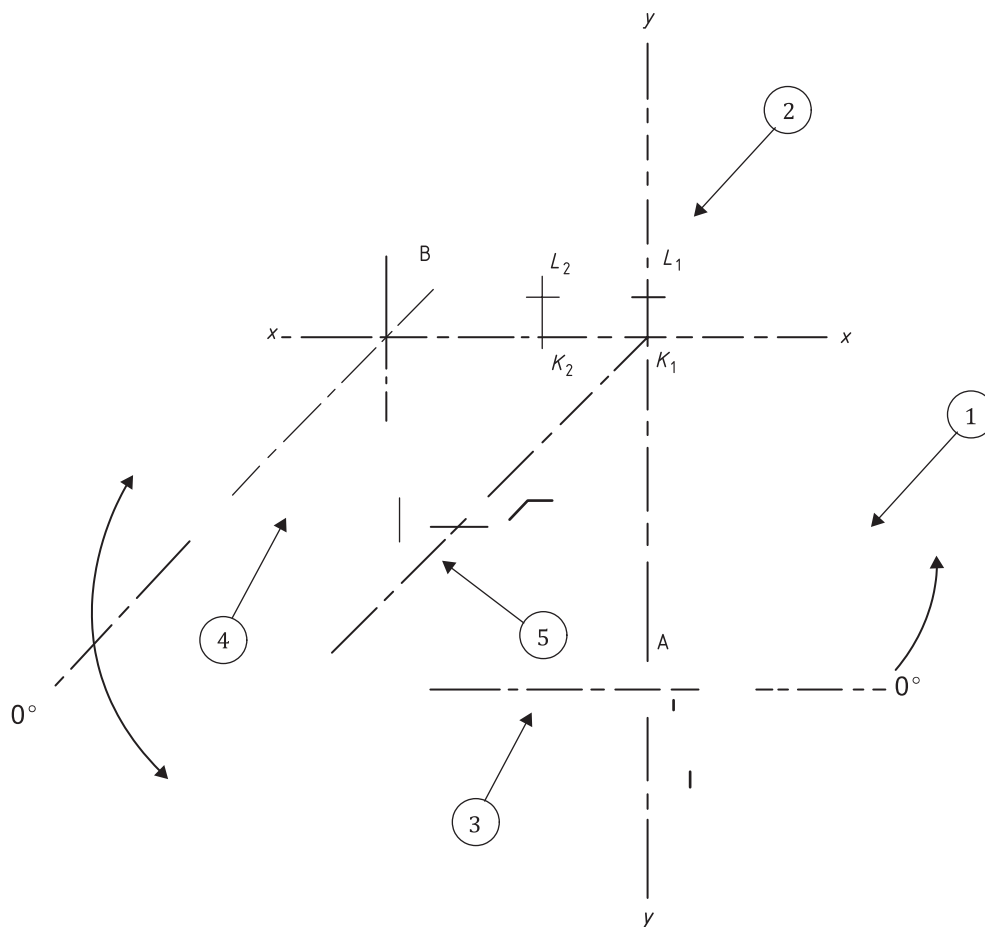

Key

- 1 base plate
- 2 headform in accordance with EN 960
- 3 horizontally pivoting arm, pivoting around point A
- 4 vertically pivoting arm, pivoting around point B
- 5 light source with focused beam of light, diameter 3 mm

Figure C.1 — Peripheral field of vision test apparatus

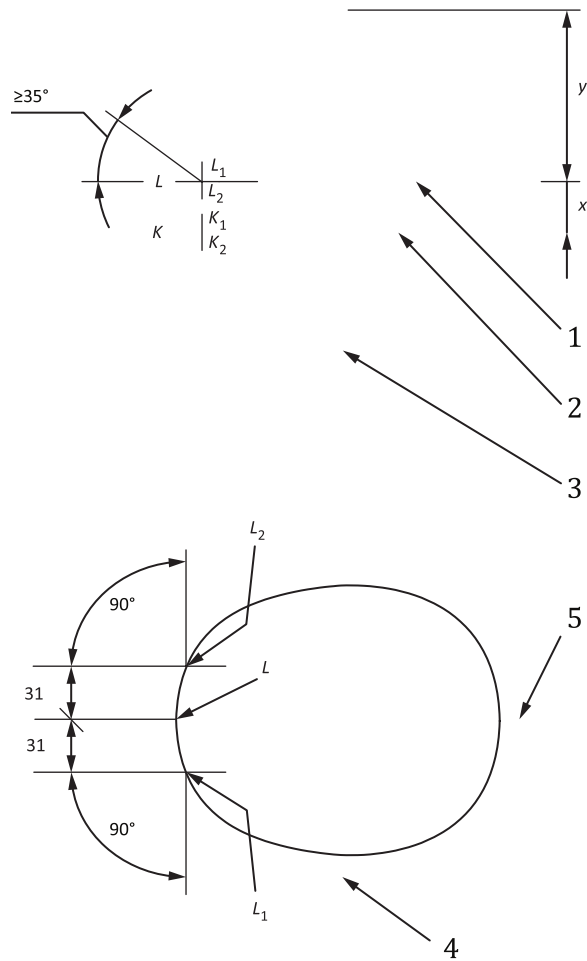

Key

- 1 reference plane
- 2 basic plan
- 3 central vertical axis
- 4 mid-frontal plane
- 5 median plane

Size designation (see EN 960)	X mm	Y mm
495	23,5	89,7
535	25,5	96
575	27,5	102,4
605	29	107,2

Figure C.2 — Field of vision for Helmets

Bibliography

- [1] CSA Standard Z262.6-14, *Specifications for facially featured headforms*

