

---

---

**Tools for pressing — Punch holder  
shanks —**

Part 1:  
**Type A**

*Outillage de presse — Nez de presse —*

*Partie 1: Type A*



Reference number  
ISO 10242-1:2011(E)

© ISO 2011



**COPYRIGHT PROTECTED DOCUMENT**

© ISO 2011

All rights reserved. Unless otherwise specified, no part of this publication may be reproduced or utilized in any form or by any means, electronic or mechanical, including photocopying and microfilm, without permission in writing from either ISO at the address below or ISO's member body in the country of the requester.

ISO copyright office  
Case postale 56 • CH-1211 Geneva 20  
Tel. + 41 22 749 01 11  
Fax + 41 22 749 09 47  
E-mail [copyright@iso.org](mailto:copyright@iso.org)  
Web [www.iso.org](http://www.iso.org)

Published in Switzerland

## Foreword

ISO (the International Organization for Standardization) is a worldwide federation of national standards bodies (ISO member bodies). The work of preparing International Standards is normally carried out through ISO technical committees. Each member body interested in a subject for which a technical committee has been established has the right to be represented on that committee. International organizations, governmental and non-governmental, in liaison with ISO, also take part in the work. ISO collaborates closely with the International Electrotechnical Commission (IEC) on all matters of electrotechnical standardization.

International Standards are drafted in accordance with the rules given in the ISO/IEC Directives, Part 2.

The main task of technical committees is to prepare International Standards. Draft International Standards adopted by the technical committees are circulated to the member bodies for voting. Publication as an International Standard requires approval by at least 75 % of the member bodies casting a vote.

Attention is drawn to the possibility that some of the elements of this document may be the subject of patent rights. ISO shall not be held responsible for identifying any or all such patent rights.

ISO 10242-1 was prepared by Technical Committee ISO/TC 29, *Small tools*, Subcommittee SC 8, *Tools for pressing and moulding*.

This third edition cancels and replaces the second edition (ISO 10242-1:1998), of which it constitutes a minor revision. In particular, the indication of surface textures has been updated in accordance with ISO 1302:2002.

ISO 10242 consists of the following parts, under the general title *Tools for pressing — Punch holder shanks*:

- *Part 1: Type A*
- *Part 2: Type C*
- *Part 3: Type D*

© ISO 2015

# Tools for pressing — Punch holder shanks —

## Part 1: Type A

### 1 Scope

This part of ISO 10242 specifies the interchangeability dimensions and tolerances, in millimetres, of punch holder shanks with neck and flats, type A, intended for use in press tools.

It gives guidance on the materials, and specifies the hardness and designation of punch holder shanks in accordance with this part of ISO 10242.

### 2 Dimensions

The dimensions of punch holder type A shank shall be in accordance with the indications of Figure 1 and Table 1.

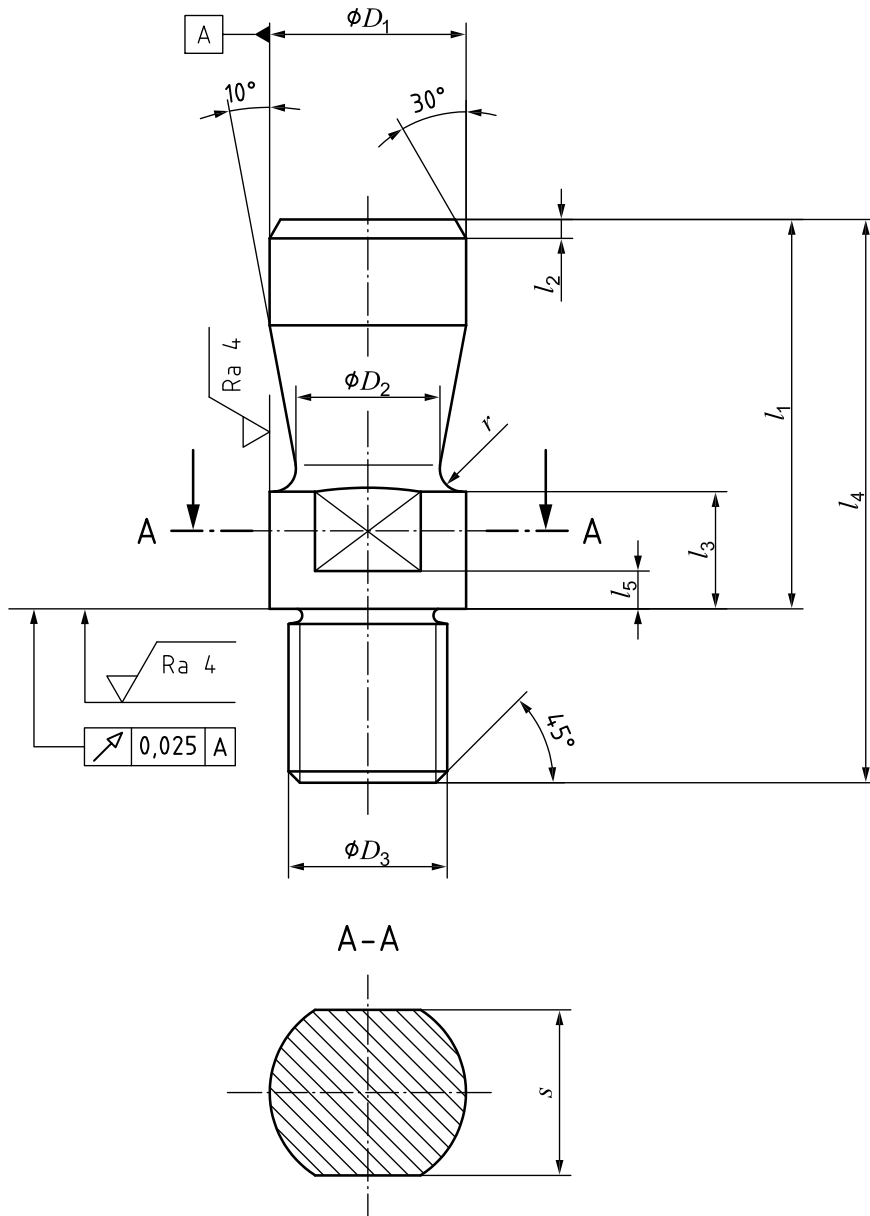
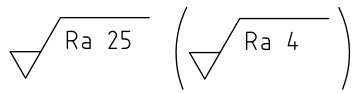

Figure 1 — Punch holder shank type A

Table 1 — Dimensions of punch holder shank type A

Dimensions in millimetres

$D_1$ f9	$D_2$	$D_3 \times P$ 6g	$l_1$	$l_2$	$l_3$	$l_4$	$l_5$ $\pm 1$	$r$	$s$
20	15	M16 $\times$ 1,5	40	2	12	58	4	2,5	17
25	20	M16 $\times$ 1,5	45	2,5	16	68	6	2,5	21
		M20 $\times$ 1,5							
32	25	M20 $\times$ 1,5	56	3	16	79	6	2,5	27
		M24 $\times$ 1,5							
40	32	M24 $\times$ 1,5	70	4	26	93	12	4	36
		M27 $\times$ 2							
		M30 $\times$ 2							
50	42	M30 $\times$ 2	80	5	26	108	12	4	41

### 3 Material and corresponding hardness

The material is left to the manufacturer's discretion, but the hardness shall be at least 140 HB.

### 4 Designation

A punch holder shank in accordance with this part of ISO 10242 shall be designated by:

- a) "Punch holder shank";
- b) reference to this part of ISO 10242, i.e. ISO 10242-1;
- c) its type;
- d) its body diameter,  $D_1$ , in millimetres;
- e) its nominal thread diameter,  $D_3$ .

EXAMPLE A punch holder shank of type A, of body diameter  $D_1 = 20$  mm and of nominal thread diameter  $D_3 = M16$  is designated as follows:

**Punch holder shank ISO 10242-1 A-20  $\times$  M16**

## Bibliography

- [1] ISO 1302:2002, *Geometrical Product Specifications (GPS) — Indication of surface texture in technical product documentation*
- [2] ISO 6506 (all parts), *Metallic materials — Brinell hardness test*





---

---

**ICS 25.120.10**

Price based on 4 pages