**Textile machinery and accessories —
Flat warp knitting machines —
Numbering of guide bars**

*Matériel pour l'industrie textile — Machines à tricoter rectilignes à
mailles jetées — Numérotage des barres à passettes*



Reference number
ISO 10223:2005(E)

© ISO 2005

PDF disclaimer

This PDF file may contain embedded typefaces. In accordance with Adobe's licensing policy, this file may be printed or viewed but shall not be edited unless the typefaces which are embedded are licensed to and installed on the computer performing the editing. In downloading this file, parties accept therein the responsibility of not infringing Adobe's licensing policy. The ISO Central Secretariat accepts no liability in this area.

Adobe is a trademark of Adobe Systems Incorporated.

Details of the software products used to create this PDF file can be found in the General Info relative to the file; the PDF-creation parameters were optimized for printing. Every care has been taken to ensure that the file is suitable for use by ISO member bodies. In the unlikely event that a problem relating to it is found, please inform the Central Secretariat at the address given below.

© ISO 2005

All rights reserved. Unless otherwise specified, no part of this publication may be reproduced or utilized in any form or by any means, electronic or mechanical, including photocopying and microfilm, without permission in writing from either ISO at the address below or ISO's member body in the country of the requester.

ISO copyright office
Case postale 56 • CH-1211 Geneva 20
Tel. + 41 22 749 01 11
Fax + 41 22 749 09 47
E-mail copyright@iso.org
Web www.iso.org

Published in Switzerland

Foreword

ISO (the International Organization for Standardization) is a worldwide federation of national standards bodies (ISO member bodies). The work of preparing International Standards is normally carried out through ISO technical committees. Each member body interested in a subject for which a technical committee has been established has the right to be represented on that committee. International organizations, governmental and non-governmental, in liaison with ISO, also take part in the work. ISO collaborates closely with the International Electrotechnical Commission (IEC) on all matters of electrotechnical standardization.

International Standards are drafted in accordance with the rules given in the ISO/IEC Directives, Part 2.

The main task of technical committees is to prepare International Standards. Draft International Standards adopted by the technical committees are circulated to the member bodies for voting. Publication as an International Standard requires approval by at least 75 % of the member bodies casting a vote.

Attention is drawn to the possibility that some of the elements of this document may be the subject of patent rights. ISO shall not be held responsible for identifying any or all such patent rights.

ISO 10223 was prepared by Technical Committee ISO/TC 72, *Textile machinery and machinery for dry-cleaning and industrial laundering*, Subcommittee SC 3, *Machinery for fabric manufacturing including preparatory machinery and accessories*.

This second edition cancels and replaces the first edition (ISO 10223:1992), which has been technically revised.

Textile machinery and accessories — Flat warp knitting machines — Numbering of guide bars

1 Scope

This International Standard specifies the designation and the numbering of guide bars for flat warp knitting machines.

NOTE The figures in this International Standard are given as examples. They do not represent the only, or even the most common arrangement.

2 Normative references

The following referenced documents are indispensable for the application of this document. For dated references, only the edition cited applies. For undated references, the latest edition of the referenced document (including any amendments) applies.

ISO 8640-1, *Textile machinery and accessories — Flat warp knitting machines — Part 1: Vocabulary of basic structure and knitting elements*

3 Terms and definitions

For the purposes of this document, the terms and definitions given in ISO 8640-1 apply.

4 Designation and abbreviation of guide bars

The numbering of guide bars — general abbreviation: B — is done from front to back and from bottom to top using continuous Arabic figures 1 to *n*.

Table 1

Designation	Abbreviation	Example with position number
Guide bar	B	B 1
Ground guide bar	GB	GB 1
Pattern guide bar	PB	PB 1
Jacquard guide bar	JB	JB 1
Filler thread guide bar	FB	FB 3

5 Numbering of guide bars

5.1 RL (single) flat warp knitting machine

5.1.1 RL (single) tricot machine

Guide bar 1 (B 1) is the foremost positioned bar with yarn guides or yarn guide units (see Figure 1).

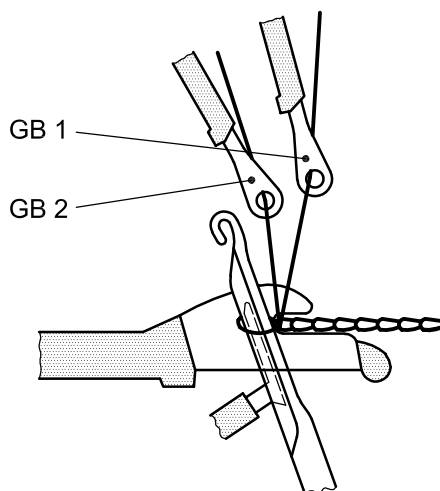

Figure 1 — RL (single) tricot machine with 2 ground guide bars (GB 1, GB 2)

5.1.2 RL (single) Raschel machine

Guide bar 1 (B 1) is the foremost positioned bar with yarn guides or yarn guide units (see Figures 2 and 3).

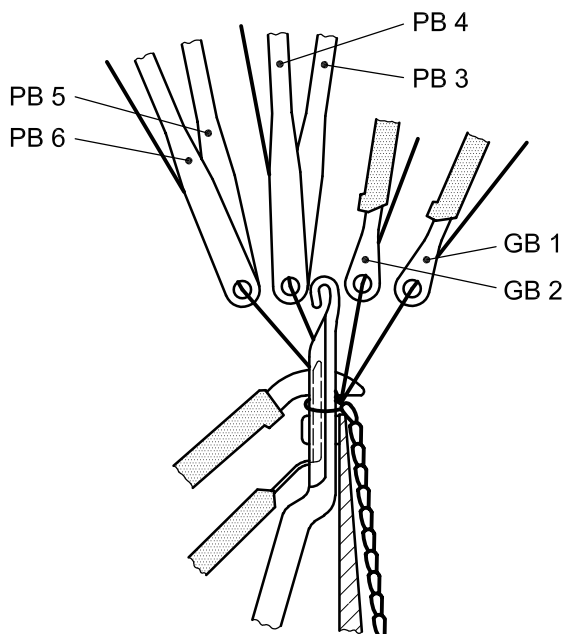

Figure 2 — RL (single) Raschel machine with 6 guide bars, of these 2 ground (GB 1, GB 2) and 4 pattern guide bars (PB 3 to PB 6)

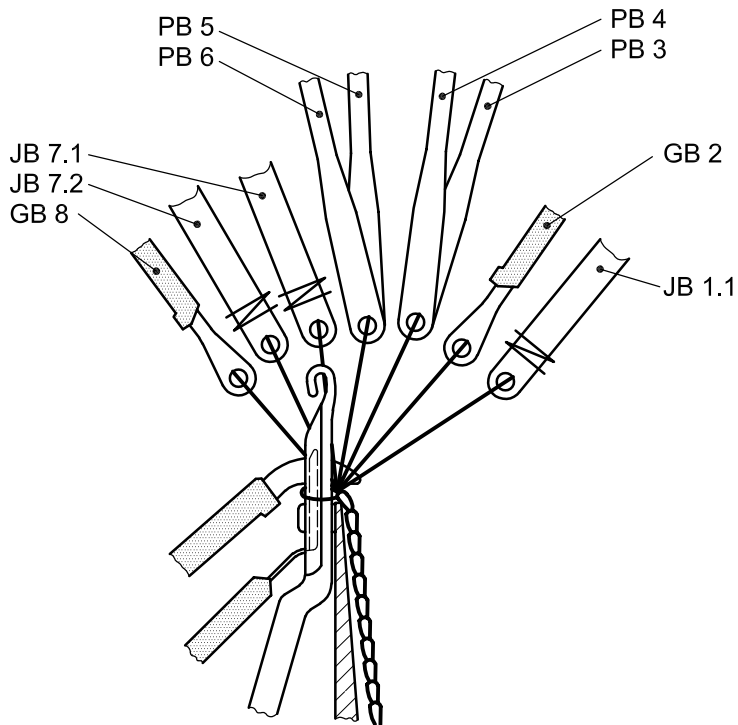

Figure 3 — (single) Raschel machine with 8 guide bars, of these 2 ground guide bars (GB 2, GB 8), 4 pattern guide bars (PB 3 to PB 6), 1 Jacquard split guide bar with half gauge (JB 1.1) and 1 Jacquard guide bar consisting of 2 Jacquard split guide bars each with half gauge (JB 7.1, JB 7.2)

5.1.3 RL (single) crochet machine

Guide bar 1 (B 1) is the foremost and lowest positioned bar with yarn guides or yarn guide units (see Figure 4).

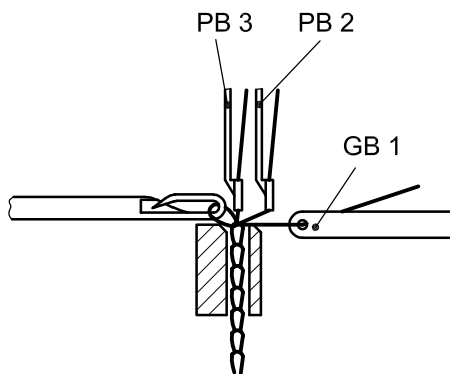

Figure 4 — RL (single) crochet machine with 3 guide bars, of these 1 ground (GB 1) and 2 pattern guide bars (PB 2, PB 3)

5.1.4 RL (single) stitch bonding machine

Guide bar 1 (B 1) is the foremost and lowest positioned bar with yarn guides or yarn guide units (see Figure 5).

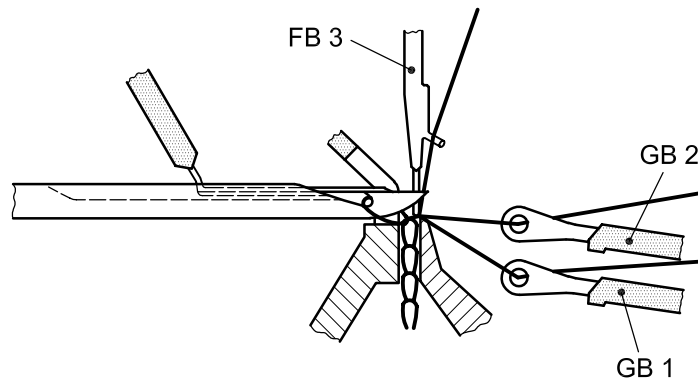

Figure 5 — RL (single) stitch bonding machine with 3 guide bars, of these 2 ground (GB 1, GB 2) and 1 filler thread guide bar (FB 3)

5.2 RR (double) flat warp knitting machine

5.2.1 RR (double) tricot machine

Guide bar 1 (B 1) is the foremost positioned bar with yarn guides or yarn guide units (see Figure 6).

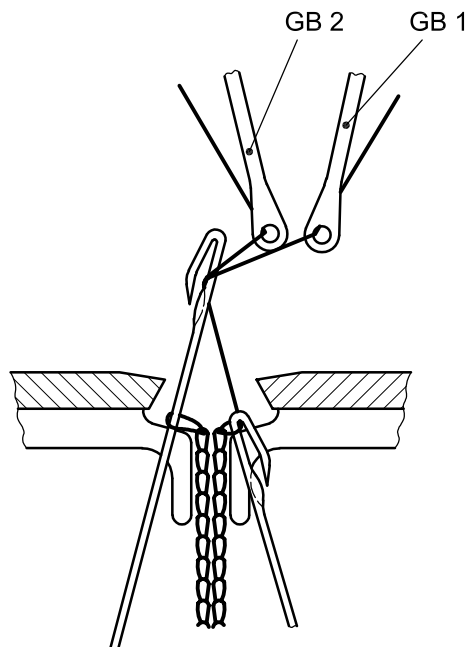

Figure 6 — RR (double) tricot machine with 2 ground guide bars (GB 1, GB 2)

5.2.2 RR (double) Raschel machine

Guide bar 1 (B 1) is the foremost positioned bar with yarn guides or yarn guide units (see Figure 7).

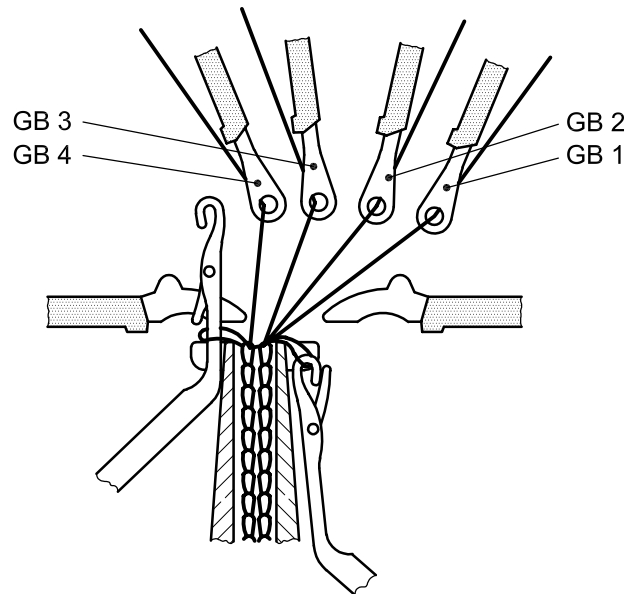

Figure 7 — RR (double) Raschel machine with 4 ground guide bars (GB 1 and GB 4)

Bibliography

- [1] ISO 7839, *Textile machinery and accessories — Knitting machines — Vocabulary and classification*

ICS 59.120.40

Price based on 6 pages