**Motorcycle chains — Characteristics and
test methods**

Chaînes pour motocycles — Caractéristiques et méthodes d'essai



Reference number
ISO 10190:2008(E)

© ISO 2008

PDF disclaimer

This PDF file may contain embedded typefaces. In accordance with Adobe's licensing policy, this file may be printed or viewed but shall not be edited unless the typefaces which are embedded are licensed to and installed on the computer performing the editing. In downloading this file, parties accept therein the responsibility of not infringing Adobe's licensing policy. The ISO Central Secretariat accepts no liability in this area.

Adobe is a trademark of Adobe Systems Incorporated.

Details of the software products used to create this PDF file can be found in the General Info relative to the file; the PDF-creation parameters were optimized for printing. Every care has been taken to ensure that the file is suitable for use by ISO member bodies. In the unlikely event that a problem relating to it is found, please inform the Central Secretariat at the address given below.



COPYRIGHT PROTECTED DOCUMENT

© ISO 2008

All rights reserved. Unless otherwise specified, no part of this publication may be reproduced or utilized in any form or by any means, electronic or mechanical, including photocopying and microfilm, without permission in writing from either ISO at the address below or ISO's member body in the country of the requester.

ISO copyright office
Case postale 56 • CH-1211 Geneva 20
Tel. + 41 22 749 01 11
Fax + 41 22 749 09 47
E-mail copyright@iso.org
Web www.iso.org

Published in Switzerland

Contents

Page

Foreword.....	iv
Introduction	v
1 Scope	1
2 Normative references	1
3 Motorcycle chains	1
3.1 Nomenclature of assemblies and components	1
3.2 Designation	2
3.3 Dimensions	2
3.4 Performance requirements and tests	2
3.4.1 General	2
3.4.2 Tensile testing	3
3.4.3 Preloading	3
3.4.4 Length validation	3
3.4.5 Dynamic testing	3
3.5 Marking	3
4 Chain sprockets	3
Annex A (normative) Alternative specification of chain sprockets for use in external drives	6
Annex B (informative) Original values	14
Annex C (normative) Method of determining the maximum test force, F_{max}, when conducting a dynamic strength conformance test	15

Foreword

ISO (the International Organization for Standardization) is a worldwide federation of national standards bodies (ISO member bodies). The work of preparing International Standards is normally carried out through ISO technical committees. Each member body interested in a subject for which a technical committee has been established has the right to be represented on that committee. International organizations, governmental and non-governmental, in liaison with ISO, also take part in the work. ISO collaborates closely with the International Electrotechnical Commission (IEC) on all matters of electrotechnical standardization.

International Standards are drafted in accordance with the rules given in the ISO/IEC Directives, Part 2.

The main task of technical committees is to prepare International Standards. Draft International Standards adopted by the technical committees are circulated to the member bodies for voting. Publication as an International Standard requires approval by at least 75 % of the member bodies casting a vote.

Attention is drawn to the possibility that some of the elements of this document may be the subject of patent rights. ISO shall not be held responsible for identifying any or all such patent rights.

ISO 10190 was prepared by Technical Committee ISO/TC 100, *Chains and chain sprockets for power transmission and conveyors*.

This second edition cancels and replaces the first edition (ISO 10190:1992), which has been technically revised.

Introduction

This International Standard has been produced to meet the increasing demands for different chains suitable for motorcycle applications. Precision roller chains specified in ISO 606 do not necessarily have the required performance for motorcycle use.

The values given in this International Standard are derived from values in Imperial units; the original values are given in Annex B for reference purposes.

Motorcycle chains — Characteristics and test methods

1 Scope

This International Standard specifies the dimensions and mechanical properties of roller and bush chains (together with details of associated chain sprockets), in the range 6,35 mm to 19,05 mm pitch, for use in motorcycle applications. These chains are suitable for external drives (e.g. rear drives).

It covers dimensions, tolerances, length measurement, preloading, minimum tensile strength and minimum dynamic strength.

2 Normative references

The following referenced documents are indispensable for the application of this document. For dated references, only the edition cited applies. For undated references, the latest edition of the referenced document (including any amendments) applies.

ISO 286-2, *ISO system of limits and fits — Part 2: Tables of standard tolerance grades and limit deviations for holes and shafts*

ISO 606, *Short-pitch transmission precision roller and bush chains, attachments and associated chain sprockets*

ISO 15654, *Fatigue test method for transmission precision roller chains*

3 Motorcycle chains

3.1 Nomenclature of assemblies and components

The nomenclature of chain assemblies and their component parts shall be as illustrated in Figures 1 and 2; the figures do not define the actual form of the chain plates.

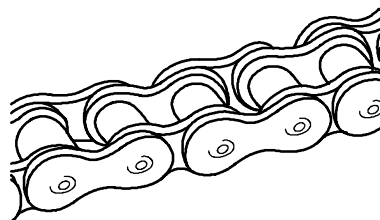
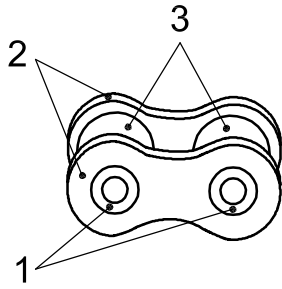
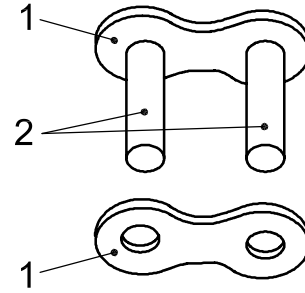

Figure 1 — Chain assembly



- Key**
- 1 bush
 - 2 inner plate
 - 3 roller

a) Roller chain — Inner link



- Key**
- 1 outer plate
 - 2 bearing pin

b) Outer link

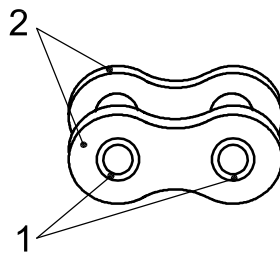

- Key**
- 1 bush
 - 2 inner plate

c) Bush chain — Inner link

Figure 2 — Types of link

3.2 Designation

Motorcycle chains shall be designated by the ISO chain number given in Table 1.

3.3 Dimensions

Chains shall conform to the dimensions shown in Figure 3 and given in Table 1.

NOTE Maximum and minimum dimensions are specified to ensure interchangeability of chains produced by different makers over the same sprockets. They are not the actual manufacturing tolerances.

3.4 Performance requirements and tests

3.4.1 General

The tests given in 3.4.2 to 3.4.5 shall be performed to determine whether the subject chain conforms to the minimum requirements specified in Table 1.

WARNING — The test requirements specified do not relate to actual chain applications; therefore, neither the values specified nor the test results should be taken as working loads.

The test results will be invalid if the chain has previously been in service or stressed in any way (other than by preloading in accordance with 3.4.3).

3.4.2 Tensile testing

3.4.2.1 The minimum tensile strength is that value which shall be exceeded when a tensile force is applied to a sample tested to destruction in accordance with 3.4.2.2.

NOTE This minimum tensile strength is not a working load, but is intended primarily as a comparative figure between chains of various constructions.

For chain application information, the chain manufacturers or their published chain data should be consulted.

3.4.2.2 Apply a tensile force slowly to the ends of a chain length containing at least five free pitches by means of fixtures permitting free movement on both sides of the chain centreline, in the normal plane of articulation.

Failure shall be considered to have occurred at the first point where increasing extension is no longer accompanied by increasing force, i.e. the summit of the force/extension diagram. The force at this point shall be equal to or exceed the minimum tensile strength stated in Table 1.

Tests in which failures occur adjacent to the fixtures shall be disregarded.

3.4.2.3 The tensile test shall be considered as a destructive test.

NOTE Even though a chain might not visibly fail when subjected to a force equivalent to the minimum tensile strength, it will have been stressed beyond the yield point and will be unfit for service.

3.4.2.4 These requirements do not apply to connecting links.

3.4.3 Preloading

The chains shall be preloaded by applying a minimum tensile force equivalent to at least 30 % of the minimum tensile strength given in Table 1.

3.4.4 Length validation

Chain length validation shall be carried out after preloading but before lubrication.

The standard length for measurement shall be a minimum of 610 mm and the chain shall terminate with an inner link at each end.

The chain shall be supported throughout its entire length and the measuring force given in Table 1 shall be applied.

The measured length shall be the nominal length $+0,25$ %.

3.4.5 Dynamic testing

Chains shall meet the requirements of the conformity test as described in ISO 15654, using the minimum dynamic strength values shown in Table 1 for the particular chain.

The maximum test force to be used shall be determined as shown in Annex C.

3.5 Marking

The chain shall be marked with the manufacturer's name or trademark, and the chain number quoted in Table 1 should be marked on the chain.

4 Chain sprockets

To ensure interchangeability between motorcycle chains and their respective chain sprockets, the sprockets for external drives shall conform to the dimensions specified in ISO 606 or alternatively to those dimensions specified in Annex A of this International Standard.

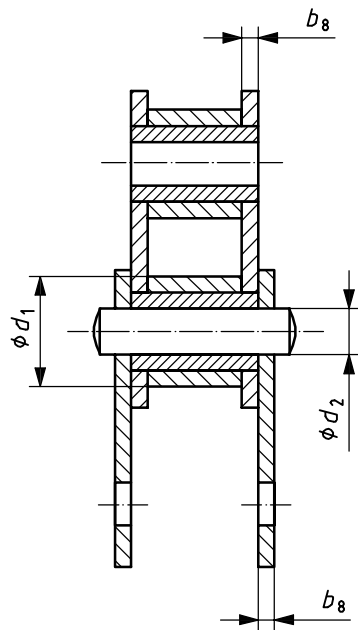

a) Roller chain

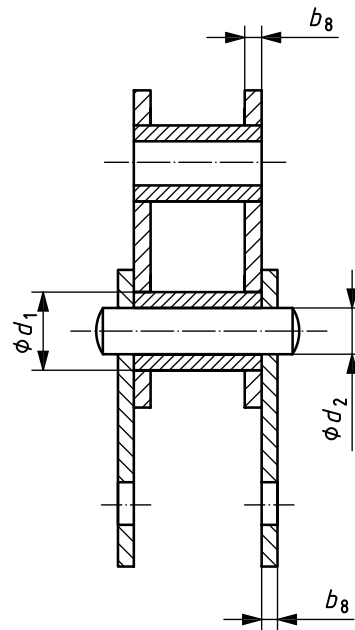

b) Bush chain

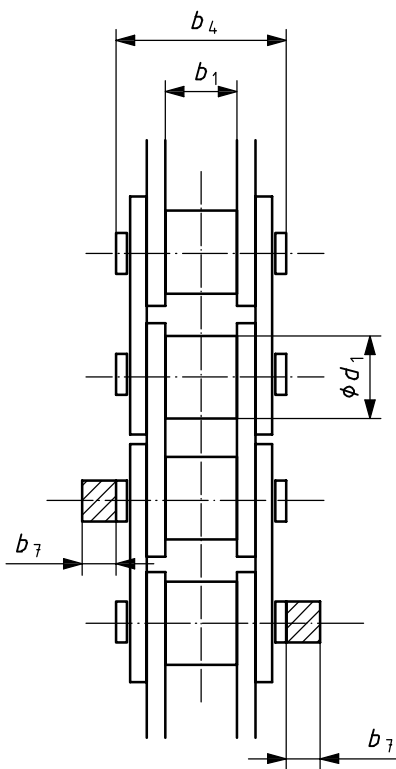

c) Chain

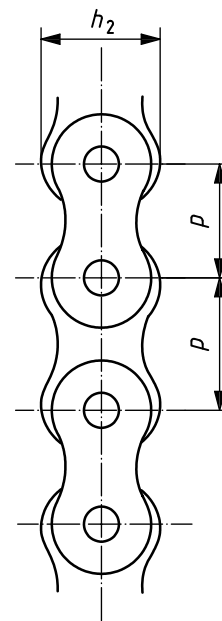

Figure 3 — Chains

Table 1 — Principal chain dimensions, measuring forces, tensile strengths and dynamic strength values

(see Figure 3)

ISO chain number	Previous ISO chain number ^d	Pitch	Maximum roller diameter	Minimum width between inner plates	Maximum bearing pin body diameter ^a	Maximum plate depth	Maximum width over bearing pins	Maximum additional width for joint fastener ^b	Plate thickness (reference value) ^a	Measuring force	Minimum tensile strength	Minimum dynamic strength
		p	d_1	b_1	d_2	h_2	b_4	b_7	b_8	F	F_u	F_d
mm										N	kN	N
25H	04 MA	6,35	3,30 ^c	3,10	2,31	6,0	9,1	1,0	1,0	50	4,8	810
219	05 MA	7,774	4,59 ^c	4,68	3,17	7,6	12,0	1,7	1,2	70	6,6	1 080
219H	—	7,774	4,59 ^c	4,68	3,17	7,6	12,6	1,7	1,4	70	7,3	1 260
05T	05 MB	8,00	4,73 ^c	4,55	3,17	7,8	12,1	1,7	1,3	70	6,8	1 190
270H	05 MC	8,50	5,00 ^c	4,75	3,28	8,6	13,3	—	1,6	70	10,8	1 720
415M	083	12,70	7,77	4,68	3,97	10,4	11,8	1,9	1,3	120	11,8	1 780
415	084	12,70	7,77	4,68	3,97	12,0	13,3	1,5	1,5	120	15,6	2 860
415MH	—	12,70	7,77	4,68	3,97	12,0	13,5	1,9	1,5	120	17,7	2 860
420	08 MA	12,70	7,77	6,25	3,99	12,0	14,9	1,5	1,5	120	15,6	2 860
420MH	—	12,70	7,77	6,25	3,99	12,0	17,5	1,5	1,8	120	18,0	3 420
428	08 MB	12,70	8,51	7,85	4,51	12,0	16,9	1,9	1,5	140	16,7	2 860
428MH	08 MC	12,70	8,51	7,85	4,51	12,0	18,9	1,9	2,0	140	20,5	3 420
520	10 MA	15,875	10,16	6,25	5,09	15,3	17,5	2,2	2,0	200	26,4	4 840
520MH	—	15,875	10,22	6,25	5,25	15,3	19,0	2,2	2,2	200	30,5	5 170
525	—	15,875	10,16	7,85	5,09	15,3	19,3	2,2	2,0	200	26,4	4 840
525MH	—	15,875	10,22	7,85	5,25	15,3	21,2	2,0	2,2	200	30,5	5 170
530	10 MB	15,875	10,16	9,40	5,09	15,3	20,8	2,1	2,0	200	26,4	4 840
530MH	—	15,875	10,22	9,40	5,40	15,3	23,1	2,0	2,4	200	30,5	5 490
630	12 MA	19,05	11,91	9,40	5,96	18,6	24,0	2,2	2,4	280	35,3	7 290

^a The bearing pin body diameter and plate thickness are given for guidance only and might differ from one brand of chain to another. Chains from different manufacturers should not therefore be joined together.

^b The additional width for joint fasteners is given for reference only. The use of joint fasteners is not recommended. Wherever possible, chains should be riveted endless.

^c Chain numbers 25H, 219, 219H, 05T and 270H are bush chains, accordingly for these chain numbers, the values in column d_1 are maximum bush diameters.

^d For reference purposes, the chain numbers from the previous version (ISO 10190:1992) are shown in the above table. Chains from the current International Standard (ISO 10190:2008) and the previous International Standard (ISO 10190:1992) do not necessarily fully correspond with each other in strength or in dimensions.

Annex A (normative)

Alternative specification of chain sprockets for use in external drives

A.1 Nomenclature

The nomenclature for chain sprockets shall be as shown in Figures A.1, A.2 and A.3.

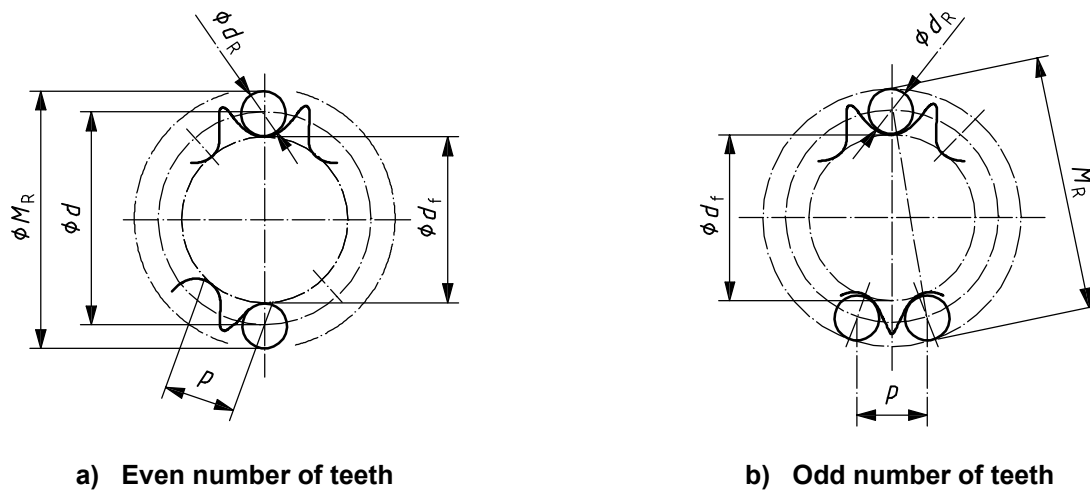

Key

- p chordal pitch, equal to chain pitch
- d_R measuring-pin diameter
- d pitch-circle diameter
- d_f root diameter
- M_R measurement over pins

NOTE This nomenclature is valid for both roller and bush chains.

Figure A.1 — Chain sprocket diametral dimensions

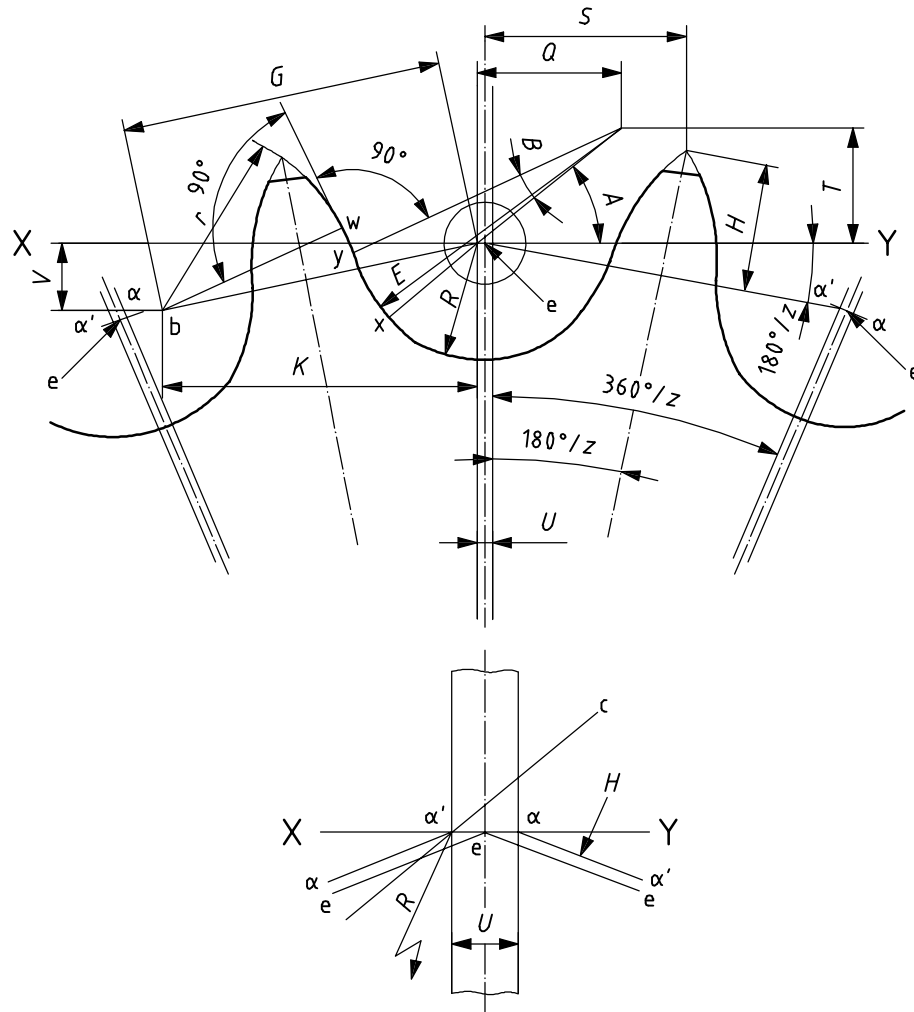

Key

- R* roller-seating radius
- E* tie-radius
- r* tooth-flank radius
- U* offset length
- z* number of teeth

Figure A.2 — Tooth gap forms

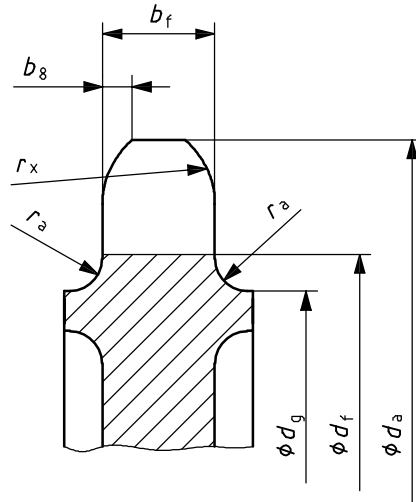

Key

- b_a tooth side relief
- b_f tooth width
- d_a tip diameter
- d_f sprocket root diameter
- d_g absolute maximum shroud diameter
- r_a shroud fillet radius
- r_x tooth side radius

NOTE Figure A.3 shows a sprocket rim in the axial plane sectioned through the centre of the tooth gap.

Figure A.3 — Sprocket rim profile

A.2 Diametral dimensions of sprocket rim

A.2.1 Dimensions

A.2.1.1 Pitch-circle diameter, d

The chain sprocket pitch-circle diameter, d , shall be calculated using the following formula:

$$d = \frac{p}{\sin \frac{180^\circ}{z}}$$

A.2.1.2 Measuring-pin diameter, d_R

The chain sprocket measuring-pin diameter, d_R , shall be calculated using the following formula, with a tolerance of $^{+0,01}_0$ mm

$$d_R = d_1$$

A.2.1.3 Root diameter, d_f

The chain sprocket root diameter, d_f , shall be calculated using the following formula with a tolerance in accordance with Table A.1.

$$d_f = d - d_1$$

Table A.1 — Root diameter tolerances

Dimensions in millimetres

Root diameter d_f	Tolerance
$d_f \leq 127$	0 – 0,25
$127 < d_f \leq 250$	0 – 0,3
$d_f > 250$	h11 ^a
^a See ISO 286-2.	

A.2.1.4 Measurement over pins

For an even number of teeth, the measurement over pins shall be calculated using the following formula:

$$M_R = d + d_{R,\min}$$

For an odd number of teeth, the measurement over pins shall be calculated using the following formula:

$$M_R = d \cos \frac{90^\circ}{z} + d_{R,\min}$$

The measurement over pins of sprockets with an even number of teeth shall be carried out over pins inserted in opposite tooth gaps.

The measurement over pins of sprockets with an odd number of teeth shall be carried out over pins in the tooth gaps most nearly opposite.

NOTE The limits of tolerance for measurement over pins are identical to those for the corresponding root diameters.

A.3 Sprocket tooth gap forms**A.3.1 Dimensions****A.3.1.1 General**

The dimensions for the tooth gap form shown in Figure A.2 shall be obtained by the use of calculation formulae shown in A.3.1.2.

NOTE Except for $2R$ and U , all the other dimensions are nominal values.

A.3.1.2 Calculation formulae for detailed dimensions

$$2R^1) = 1,005d_1 + 0,076$$

$$U^1) = 0,07(p - d_1) + 0,051$$

$$A = 35^\circ + \frac{60^\circ}{z}$$

$$B = 18^\circ - \frac{56^\circ}{z}$$

$$ac = 0,8d_1$$

$$Q = 0,8d_1 \cos\left(35^\circ + \frac{60^\circ}{z}\right)$$

$$T = 0,8d_1 \sin\left(35^\circ + \frac{60^\circ}{z}\right)$$

$$E = cy = 1,3025d_1 + 0,038$$

Chordal length of arc xy

$$= \overline{xy} = (2,605 d_1 + 0,076) \sin\left(9^\circ - \frac{28^\circ}{z}\right)$$

$$yw = d_1 \left[1,4 \sin\left(17^\circ - \frac{64^\circ}{z}\right) - 0,8 \sin\left(18^\circ - \frac{56^\circ}{z}\right) \right]$$

$G = a'b = 1,4d_1$ Point b is on the straight line which consists of a corner of line xy

with an angle of $\frac{180^\circ}{z}$.

$$K = 1,4d_1 \cos \frac{180^\circ}{z}$$

$$V = 1,4d_1 \sin \frac{180^\circ}{z}$$

$$F = d_1 \left[0,8 \cos\left(18^\circ - \frac{56^\circ}{z}\right) + 1,4 \cos\left(17^\circ - \frac{64^\circ}{z}\right) - 1,3025 \right] - 0,038$$

$$\text{Tooth pitch (e-e)} = p_a = p \left(1 + \frac{2R - d_1}{d} \right)$$

1) It is permissible to increase the calculated values of $2R$ and U within the range of $0,003d_1 + 0,127$.

$$H = \sqrt{F^2 - \left(1,4d_1 - \frac{p_a}{2} + \frac{U}{2} \cos \frac{180^\circ}{z}\right)^2} + \frac{U}{2} \sin \frac{180^\circ}{z}$$

$$S = \frac{p_a}{2} \cos \frac{180^\circ}{z} + H \sin \frac{180^\circ}{z}$$

$$\text{Tip diameter of sprockets with pointed teeth } ^2) = p_a \cot \frac{180^\circ}{z} + 2H$$

$$\text{The maximum pressure angle} = x_{ab} = 35^\circ - \frac{120^\circ}{z}$$

$$\text{The minimum pressure angle} = x_{ab} - B = 17^\circ - \frac{64^\circ}{z}$$

$$\text{The average pressure angle} = 26^\circ - \frac{92^\circ}{z}$$

The dimension of d_s for sprockets for 520MH, 525MH and 530MH shall be calculated using the value of $d_1 = 10,16$ mm.

A.4 Tip diameters

A.4.1 Nomenclature

See Figure A.3.

A.4.2 Dimensions

The maximum and minimum values of the tip diameter d_a shall be calculated using the following formulae:

$$d_{a,\max} = p \left(0,60 + \cot \frac{180^\circ}{z} \right)$$

$$d_{a,\min} = p \left(0,43 + \cot \frac{180^\circ}{z} \right)$$

A.5 Sprocket rim profiles

A.5.1 Nomenclature

See Figure A.3.

2) This is the tip diameter. See A.4.2 for tolerance.

A.5.2 Dimensions

A.5.2.1 Tooth width

Tooth width dimensions shall be obtained using the following formulae, where h_{14} is as specified in ISO 286-2.

a) For $p \leq 12,7$ mm:

$$b_f = 0,93b_1 : h_{14}$$

b) For $p > 12,7$ mm:

$$b_f = 0,95b_1 : h_{14}$$

A.5.2.2 Other dimensions

For all chains:

$$r_{x,nom}^{3)} = p$$

For chain numbers 415, 415M and 415H:

$$b_{a,nom} = 0,06p$$

For all other chains:

$$b_{a,nom} = 0,13p$$

For chain number 25H:

$$d_g = p \cot \frac{180^\circ}{z} - 1,05h_2 - 1,00 - 2r_a$$

For all other chains:

$$d_g = p \cot \frac{180^\circ}{z} - 1,04h_2 - (0,76 \text{ mm})$$

A.6 Radial run-out

Radial run-out between the bore and root diameter shall not exceed a total indicator reading of greater than the larger of the two following values:

$$(0,0008 d_f + 0,08) \text{ mm, or}$$

$$0,15 \text{ mm,}$$

up to a maximum of 0,76 mm.

A.7 Axial run-out (wobble)

Axial run-out, measured with reference to the bore and the flat part of the side face of the teeth, shall not exceed a total indicator reading of

$$(0,0009 d_f + 0,08) \text{ mm,}$$

up to a maximum of 1,14 mm.

NOTE For fabricated (welded) sprockets, 0,25 mm is acceptable if the above formula gives smaller values.

3) The chamfer of the side face is also an admitted straight line.

A.8 Pitch accuracy of sprocket teeth

Pitch accuracy of sprocket teeth is important and chain manufacturers should be consulted for details.

A.9 Bore tolerance

Unless otherwise agreed between manufacturer and purchaser, bore tolerance should be H8, where H8 is as specified in ISO 286-2.

A.10 Marking

Sprockets shall be marked with the following:

- a) manufacturer's name or trademark;
- b) number of teeth;
- c) chain designation (ISO chain number and/or manufacturer's equivalent).

Annex B (informative)

Original values

Table B.1 gives, for reference purposes, the original values from which this International Standard was derived.

Table B.1 — Original principal chain dimensions, measuring forces and tensile strengths

ISO chain number	Pitch	Width between inner plates	Width over bearing pin	Additional width for joint fastener ^b	Plate thickness ^a	Roller/Bush diameter	Bearing pin body diameter ^a	Plate depth	Tensile strength	Measuring force	Dynamic test upper force	Dynamic test lower force
	<i>P</i>	<i>b</i> ₁ (min.)	<i>b</i> ₄ (max.)	<i>b</i> ₇ (max.)	<i>b</i> ₈ (nom.)	<i>d</i> ₁ (max.)	<i>d</i> ₂ (nom.)	<i>h</i> ₂ (max.)	(min.)	<i>F</i>	<i>F</i> ₁	<i>F</i> ₂
in									lbf			
083 ^c	0,5	0,192	0,508	0,059	0,055	0,305	0,157	0,406	2 607	27	—	—
084 ^c	0,5	0,192	0,583	0,059	0,067	0,305	0,157	0,441	3 505	27	—	—
04 MA ^d	0,25	0,122	0,358	0,059	0,039	0,13	0,09	0,236	1 011	11	225	45
05 MA ^d	0,306	0,164	0,472	0,063	0,047	0,181	0,118	0,299	1 483	16	292	45
05 MB ^d	0,315	0,225	0,547	0,063	0,055	0,188	0,13	0,299	2 000	16	449	45
05 MC ^d	0,335	0,187	0,524	0,067	0,071	0,197	0,13	0,339	2 202	16	494	49
08 MA	0,5	0,246	0,63	0,063	0,059	0,306	0,157	0,476	3 371	27	786	79
08 MB	0,5	0,305	0,669	0,098	0,059	0,335	0,173	0,492	4 000	27	831	83
08 MC	0,5	0,305	0,76	0,098	0,079	0,335	0,173	0,492	4 629	27	989	99
08 MB-2 ^e	0,5	0,305	1,228	0,098	0,059	0,335	0,173	0,492	6 988	56	1 438	144
10 MA	0,625	0,246	0,748	0,098	0,079	0,4	0,205	0,602	5 955	45	1 528	153
10 MB	0,625	0,37	0,866	0,098	0,079	0,4	0,205	0,602	5 955	45	1 528	153
12 MA	0,75	0,37	0,945	0,11	0,094	0,469	0,232	0,732	7 865	63	2 022	202

^a The bearing pin body diameter and plate thickness are given for guidance only and might differ from one brand of chain to another. Chains from different manufacturers should not therefore be joined together.

^b The additional width for joint fasteners is given for reference only. The use of joint fasteners is not recommended. Wherever possible, chains should be riveted endless.

^c Chain numbers 083 and 084 are intended for use on mopeds only. They have been transferred to this International Standard from ISO 606.

^d Chain numbers 04 MA, 05 MA, 05 MB and 05 MC are bush chains.

^e Chain number 08 MB-2 is a duplex chain with a transverse pitch $p_t = 0,566$ in.

Annex C (normative)

Method of determining the maximum test force, F_{\max} , when conducting a dynamic strength conformance test

C.1 General

The maximum test force, F_{\max} , is given by:

$$F_{\max} = \frac{F_d F_u + [F_{\min} (F_u - F_d)]}{F_u}$$

where

F_{\max} is the maximum dynamic test force, expressed in newtons (N);

F_d is the minimum dynamic strength as shown in Table 1, expressed in newtons (N);

F_u is the minimum tensile strength as shown in Table 1, expressed in newtons (N);

F_{\min} is the minimum test force, expressed in newtons (N).

C.2 Example for chain 520

If the chain manufacturer were to choose a minimum test force, F_{\min} , of 680 N, then the maximum test force (F_{\max}) would be determined as follows:

As F_{\max} is given by:

$$F_{\max} = \frac{F_d F_u + [F_{\min} (F_u - F_d)]}{F_u}$$

and from Table 1:

$$F_d = 4\,840 \text{ N and } F_u = 26\,400 \text{ N}$$

then:

$$F_{\max} = \frac{(4\,840 \times 26\,400) + [680(26\,400 - 4\,840)]}{26\,400} = 5\,395,3 \text{ N}$$

which can be rounded down to a value of:

$$F_{\max} = 5\,390$$

ICS 43.140

Price based on 15 pages
