

---

**Steel — Determination of boron content —  
Curcumin spectrophotometric method**

*Aciers — Dosage du bore — Méthode spectrophotométrique  
à la curcumine*

This material is reproduced from ISO documents under International Organization for Standardization (ISO) Copyright License number IHS/ICC/1996. Not for resale. No part of these ISO documents may be reproduced in any form, electronic retrieval system or otherwise, except as allowed in the copyright law of the country of use, or with the prior written consent of ISO (Case postale 56, 1211 Geneva 20, Switzerland, Fax +41 22 734 10 79), IHS or the ISO Licensor's members.



Reference number  
ISO 10153:1997(E)

## Foreword

ISO (the International Organization for Standardization) is a worldwide federation of national standards bodies (ISO member bodies). The work of preparing international Standards is normally carried out through ISO technical committees. Each member body interested in a subject for which a technical committee has been established has the right to be represented on that committee. International organizations, governmental and non-governmental, in liaison with ISO, also take part in the work. ISO collaborates closely with the International Electrotechnical Commission (IEC) on all matters of electrotechnical standardization.

Draft International Standards adopted by the technical committees are circulated to the member bodies for voting. Publication as an International Standard requires approval by at least 75 % of the member bodies casting a vote.

International Standard ISO 10153 was prepared by Technical Committee ISO/TC 17, *Steel*, Subcommittee SC 1, *Methods of determination of chemical composition*.

This second edition cancels and replaces the first edition (ISO 10153:1991), of which it constitutes a technical revision.

Annexes A to D of this international Standard are for information only.

© ISO 1997

All rights reserved. Unless otherwise specified, no part of this publication may be reproduced or utilized in any form or by any means, electronic or mechanical, including photocopying and microfilm, without permission in writing from the publisher.

International Organization for Standardization  
Case postale 56 • CH-1211 Genève 20 • Switzerland  
Internet: [central@iso.ch](mailto:central@iso.ch)  
X.400: c=ch; a=400net; p=iso; o=isocs; s=central

Printed in Switzerland

# Steel — Determination of boron content — Curcumin spectrophotometric method

## 1 Scope

This International Standard specifies a curcumin spectrophotometric method for the determination of the boron content in steel.

The method is applicable to a boron content of between 0,000 1 % (*m/m*) and 0,000 5 % (*m/m*) only in unalloyed steel, and between 0,000 5 % (*m/m*) and 0,012 % (*m/m*) in steel.

## 2 Normative references

The following standards contain provisions which, through reference in this text, constitute provisions of this International Standard. At the time of publication, the editions indicated were valid. All standards are subject to revision, and parties to agreements based on this International Standard are encouraged to investigate the possibility of applying the most recent editions of the standards indicated below. Members of IEC and ISO maintain registers of currently valid International Standards.

ISO 385-1 : 1984, *Laboratory glassware - Burettes — Part 1: General requirements*.

ISO 648 : 1977, *Laboratory glassware - One-mark pipettes*.

ISO 1042 :—<sup>1)</sup>, *Laboratory glassware - One-mark volumetric flasks*.

ISO 3696 : 1987, *Water for analytical laboratory use - Specification and test methods*.

ISO 5725-1:1994, *Accuracy (trueness and precision) of measurement methods and results— Part 1: General principles and definitions*.

ISO 5725-2:1994, *Accuracy (trueness and precision) of measurement methods and results— Part 2: Basic method for the determination of repeatability and reproducibility of a standard measurement method*.

ISO 5725-3:1994, *Accuracy (trueness and precision) of measurement methods and results— Part 3: Intermediate measures of the precision of a standard measurement method*.

ISO 14284 :1997, *Steel and iron - Sampling and preparation of samples for the determination of chemical composition*.

## 3 Principle

Dissolution of a test portion in hydrochloric and nitric acids.

Decomposition of boron compounds (nitrides etc.) with orthophosphoric and sulfuric acids at a temperature of 290 °C.

Formation of a coloured complex between orthoboric acid and curcumin in a buffered acetic medium.

Spectrophotometric measurement at a wavelength of about 543 nm.

<sup>1)</sup> To be published. (Revision of ISO 1042:1983)

## 4 Reagents

During the analysis, unless otherwise stated, use only reagents of recognized analytical grade and having a very low boron content and only grade 2 water as specified in ISO 3696.

**4.1 Pure iron**, free from boron or with a known residual amount of boron.

**4.2 Sodium hypophosphite monohydrate**,  $\text{NaH}_2\text{PO}_2 \cdot \text{H}_2\text{O}$

**4.3 Hydrochloric acid**,  $\rho$  about 1,19 g/ml.

**4.4 Nitric acid**,  $\rho$  about 1,40 g/ml.

**4.5 Sulfuric acid**,  $\rho$  about 1,84 g/ml.

**4.6 Orthophosphoric acid**,  $\rho$  about 1,71 g/ml.

**4.7 Acetic acid**, free from aldehyde,  $\rho$  about 1,05 g/ml.

In order to test the acetic acid for the presence of aldehyde, pour 20 ml of acetic acid ( $\rho$  about 1,05 g/ml) and 1 ml of potassium permanganate solution (1 g/l) into a 50 ml beaker. In the absence of aldehyde, the initial violet colour of potassium permanganate will persist; otherwise the solution will become an easily identifiable brown colour after 15 min.

**4.8 Mixture of acetic and sulfuric acids.**

While cooling under water and swirling, add in small portions a volume of sulfuric acid (4.5) to an equal volume of acetic acid (4.7).

**4.9 Acetic buffer solution.**

Dissolve 225 g of ammonium acetate in 400 ml of water. Add 300 ml of acetic acid (4.7). Filter the solution obtained into a 1 000 ml polypropylene volumetric flask. Dilute to the mark with water and mix.

**4.10 Sodium fluoride, 40 g/l solution.**

Store in a polypropylene bottle.

**4.11 Boron, standard solution.**

**4.11.1 Stock solution**, corresponding to 0,10 g of B per litre.

Weigh, to the nearest 0,000 1 g, 0,266 0 g of orthoboric acid ( $\text{H}_3\text{BO}_3$ ). Place in a 250 ml beaker and dissolve in about 200 ml of water. Transfer the solution quantitatively to a 500 ml one-mark volumetric flask. Dilute to the mark with water and mix. Store in a polypropylene bottle.

1 ml of this stock solution contains 0,10 mg of B.

**4.11.2 Standard solution**, corresponding to 0,002 g of B per litre.

Transfer 20,0 ml of the stock solution (4.11.1) to a 1 000 ml one-mark volumetric flask. Dilute to the mark with water and mix. Store in a polypropylene bottle.

Prepare this standard solution immediately before use.

1 ml of this standard solution contains 2  $\mu\text{g}$  of B.

#### 4.12 Curcumin, acetic acid solution, 1,25 g/l.

Weigh 0,125 g of curcumin,  $[\text{CH}_3\text{O}(\text{OH})\text{C}_6\text{H}_6\text{CH}=\text{CHCO}]_2\text{CH}_3$ , in a polypropylene or quartz vessel, add 60 ml of acetic acid (4.7) and mix. Heat in a water bath at 40 °C and stir using a magnetic stirrer. After dissolution, cool and transfer to a 100 ml polypropylene volumetric flask. Dilute to the mark with acetic acid and mix.

### 5 Apparatus

Glassware containing boron shall not be used and shall be replaced by polypropylene or quartz equipment rinsed with acetic acid (4.6) then with water and finally dried. All volumetric glassware shall be grade A, in accordance with ISO 385-1, ISO 648 or ISO 1042, as appropriate.

Ordinary laboratory apparatus and the following shall be used.

**5.1 Quartz beakers with quartz covers**, of capacity 100 ml, external dimensions: 51 mm diameter and 70 mm height.

**5.2 Polypropylene volumetric flasks**, of capacities 50 ml and 100 ml.

**5.3 Aluminium alloy block**, with holes designed to allow the positioning of the 100 ml quartz beakers, heated by surface contact with a hot plate. Diagrams of such blocks are shown in annex A.

NOTE 1 The dimensions of the holes should be adapted to the dimensions of the quartz beakers available.

**5.4 Spectrophotometer**, suitable for measuring the absorbance of the solution at a wavelength of 543 nm with 2 cm optical cells.

### 6 Sampling

Carry out sampling in accordance with ISO 14284 or appropriate national standards for steel.

The size of the chip used shall be smaller than 1 mm.

### 7 Procedure

#### 7.1 Test portion

Weigh, to the nearest 0,000 2 g, a test portion of mass  $m$ , as a function of the expected boron content as follows:

- content from 0,000 1 % ( $m/m$ ) to 0,006 % ( $m/m$ ),  $m$  is approximately 1,00 g;
- content from 0,006 % ( $m/m$ ) to 0,012 % ( $m/m$ ),  $m$  is approximately 0,50 g.

For grades of steel with nickel content plus cobalt content greater than 30 % ( $m/m$ ), use a test portion of approximately 0,50 g.

#### 7.2 Blank test

Carry out an analysis on a portion of pure iron (4.1), corresponding to the mass of test portion used (see 7.1), in parallel with the test portion analysis, using identical reagents, conditions, analytical procedure and dilutions throughout. The absorbance of the blank test solution ( $A_b$ ) and that of the blank compensating solution ( $A_c$ ) are thus obtained.

## 7.3 Determination

### 7.3.1 Preparation of the test solution

Place the test portion (7.1) in a 100 ml quartz beaker (5.1). Add 10 ml of hydrochloric acid (4.3) and 5 ml of nitric acid (4.4), cover the beaker with a quartz cover (5.1) and maintain the solution at the ambient temperature (see note 2).

NOTE 2 Maintaining the ambient temperature is most important, in order to avoid possible loss of boron at higher temperatures.

When dissolution is complete, carefully add 10 ml of orthophosphoric acid (4.6) and 5 ml of sulfuric acid (4.5).

Heat until white sulfuric acid fumes are generated. Place the reaction beaker in a hole in the aluminium alloy block (5.3) and place this on a heat source permitting a temperature of 290 °C (see note 3) to be obtained in the solution. Maintain heating for 30 min, taking care to replace the quartz cover after the appearance of white fumes, swirling from time to time in order to recover any particles attached to the side of the beaker.

NOTE 3 The temperature of  $(290 \pm 5)$  °C is obtained by calibrating the heat source with a thermometer, graduated from 0 °C to 350 °C, immersed in a test beaker containing the same amounts of dissolution reagents.

Remove the beaker from the heat source and allow to cool. Add 30 ml of water to the syrupy solution, warm and stir.

**CAUTION** — It is essential that care is taken after the addition of 30 ml of water, when the solution is warmed. A sudden eruption may occur resulting in loss of the test solution.

Then, carefully add 5 ml of hydrochloric acid (4.3) and bring to the boil. Add 3 g of sodium hypophosphite (4.2) and allow to boil very gently for 15 min.

Remove the beaker from the heat source and allow to cool. Transfer the solution quantitatively to a 50 ml polypropylene volumetric flask (5.2), dilute to the mark with water and mix.

### 7.3.2 Formation of the coloured complex

**7.3.2.1** Take a 1,0 ml aliquot of the test solution (see 7.3.1) and transfer it to a 100 ml polypropylene volumetric flask (5.2) which has previously been cleaned and dried.

**7.3.2.2** Add to the flask, while swirling to avoid contact with the stopper, the following quantities of reagents.

- 6,0 ml of the mixture of acetic and sulfuric acids (4.8), avoiding contact of the pipette with the neck and sides of the flask. Then mix.
- 6,0 ml of curcumin acetic acid solution (4.12). Stopper the flask and mix. Leave to stand for 2 h 30 min for complete development of the colour.
- 1,0 ml of orthophosphoric acid (4.6) to stabilize the colour. Shake and allow to stand for 30 min.
- 30,0 ml of acetic buffer solution (4.9). The solution becomes orange. Stopper, shake and allow to stand for exactly 15 min.

### 7.3.3 Preparation of the compensating solution

Take a 1,0 ml aliquot of the test solution (see 7.3.1) and transfer it to a 100 ml polypropylene volumetric flask (5.2) which has previously been cleaned and dried. Add 0,2 ml of sodium fluoride solution (4.10) to the bottom of the flask.

Carefully swirl the small volume of solution. Leave to stand for 1 h.

Proceed as specified in 7.3.2.2.

### 7.3.4 Spectrophotometric measurements

Adjust the spectrophotometer to zero absorbance by reference to water. Perform the spectrophotometric measurement (see note 4) of the colour-developed test solution (see 7.3.2) and the corresponding compensating solution (see 7.3.3) at a wavelength of 543 nm using 2 cm cells.

The absorbances of the test solution ( $A$ ) and the compensating solution ( $A_c$ ) are thus obtained.

NOTE 4 In order to carry out the spectrophotometric measurements on all the solutions whilst waiting exactly 15 min after the addition of acetic buffer solution (see 7.3.2), it is advisable to divide them into series of six measurements, i.e. 12 flasks. In fact, for long series of measurements where the waiting time cannot be strictly adhered to, the formation of a cloudiness in the solutions can be observed and consequently erroneous results obtained.

## 7.4 Establishment of the calibration graph

### 7.4.1 Preparation of calibration solutions

Place  $(1,00 \pm 0,01)$ g portions of iron (4.1) in a series of 100 ml quartz beakers and add the volumes of boron standard solution (4.11.2) as indicated in table 1 for a boron content up to 0,000 5 % ( $m/m$ ) and table 2 for a boron content more than 0,000 5 % ( $m/m$ ).

Proceed as specified in 7.3.1, 7.3.2 and 7.3.3.

### 7.4.2 Spectrophotometric measurements

Adjust the spectrophotometer to zero absorbance by reference to water. Perform the spectrophotometric measurements of the range of calibration solutions, with and without sodium fluoride solution (4.10), at a wavelength of 543 nm using 2 cm cells.

### 7.4.3 Plotting the calibration graph

Calculate the difference in absorbance between the solutions with and without sodium fluoride and subtract the value obtained for the zero member from these calculated values.

Prepare the straight line calibration graph, which passes through the origin, by plotting the net absorbance reading against micrograms of boron.

## 8 Expression of results

### 8.1 Calculation of the net absorbance

Calculate the difference in absorbance for each solution to be determined and subtract the value for the blank test obtained under the same conditions. The net absorbance for the boron content to be determined is given by the equation

$$A_s = (A - A_c) - (A_b - A_{bc})$$

where

- $A_s$  is the net absorbance for the boron content to be determined;
- $A$  is the absorbance of the test solution;
- $A_b$  is the absorbance of the blank test solution;
- $A_c$  is the absorbance of the compensating solution for the test solution;
- $A_{bc}$  is the absorbance of the compensating solution for the blank test solution.

## 8.2 Calculation of the boron content

Convert the net absorbance into the corresponding mass, expressed in micrograms of boron in the test solution, by using the calibration graph (7.4.3).

The boron content,  $w_B$ , expressed as a percentage by mass, is given by the equation

$$w_B = \frac{m_B}{10^6} \times \frac{100}{m} + w_{B,0} - \frac{m_B}{10^4 m} + w_{B,0}$$

where

$m_B$  is the mass, expressed in micrograms, of boron in the test solution;

$m$  is the mass, in grams, of the test portion (7.1);

$w_{B,0}$  is the boron content, expressed as a percentage by mass, in the pure iron (4.1). (It may be neglected when it does not affect the accuracy.)

**Table 1 — Calibration solution for boron content between 0,000 1 % (m/m) and 0,000 5 % (m/m)**

Volume of boron standard solution (4.11.2) ml	Corresponding mass of boron µg	Boron content of the test sample
		% (m/m)
0 <sup>1)</sup>	0	0
0,5	1,0	0,000 1
1,0	2,0	0,000 2
2,0	4,0	0,000 4
2,5	5,0	0,000 5

1) Zero member

**Table 2 — Calibration solution for boron content between 0,000 5 % (m/m) and 0,012 0 % (m/m)**

Volume of boron standard solution (4.11.2) ml	Corresponding mass of boron µg	Boron content of the test sample % (m/m)	
		Test portion of 1,00 g	Test portion of 0,50 g
0 <sup>1)</sup>	0	0	0
2,5	5	0,000 5	0,001 0
5,0	10	0,001 0	0,002 0
10,0	20	0,002 0	0,004 0
20,0	40	0,004 0	0,008 0
30,0	60	0,006 0	0,012 0

1) Zero member



### 8.3 Precision

Planned trials of this method were carried out by 14 laboratories in six countries, at five levels of boron in the lower range of unalloyed steels, and by 21 laboratories in eight countries, at eight levels of boron in the higher range of steels, each laboratory making three determinations (see notes 5 and 6) of boron content at each level.

#### NOTES

5 Two of the three determinations were carried out under repeatability conditions as defined in ISO 5725-1; i.e. one operator, same apparatus, identical operating conditions, same calibration, and a minimum period of time.

6 The third determination was carried out at a different time (on a different day) by the same operator as in note 5, using the same apparatus with a new calibration.

The test samples used are listed in table B.1 and table B.2.

The results obtained were treated statistically in accordance with ISO 5725, Parts 1, 2 and 3, using the data obtained from the samples containing four levels of boron in the lower range of unalloyed steel and six levels of boron in the higher range of steels, respectively within the application range.

The data obtained showed a logarithmic relationship between boron content and repeatability limit ( $r$ ) and reproducibility limits ( $R$  and  $R_w$ ) of the test results (see note 7), as summarized in table 3 and table 4. The graphical representations of the figures are given in annex C.

NOTE 7 From the results obtained on day 1, the repeatability limit ( $r$ ) and the reproducibility limit ( $R$ ) were calculated using the procedure specified in ISO 5725-2. From the first result obtained on day 1 and the result obtained on day 2, the within-laboratory reproducibility limit ( $R_w$ ) was calculated using the procedure specified in ISO 5725-3.

The same method was tested by 14 laboratories in seven countries belonging to ECISS/TC 20 using samples containing eight levels of boron. The results of these precision tests are listed in table D.1 for information.

**Table 3 — Precision data for boron content between 0,000 1 % (m/m) and 0,000 5 % (m/m)**

Boron content % (m/m)	Repeatability limit $r$	Reproducibility limits	
		$R$	$R_w$
0,000 1	0,000 04	0,000 09	0,000 05
0,000 2	0,000 06	0,000 14	0,000 08
0,000 5	0,000 10	0,000 25	0,000 14

**Table 4 — Precision data for boron content between 0,000 5 % (m/m) and 0,012 0 % (m/m)**

Boron content % (m/m)	Repeatability limit $r$	Reproducibility limits	
		$R$	$R_w$
0,000 5	0,000 14	0,000 28	0,000 17
0,001 0	0,000 20	0,000 39	0,000 25
0,002 0	0,000 28	0,000 55	0,000 37
0,005 0	0,000 43	0,000 89	0,000 62
0,010 0	0,000 50	0,001 25	0,000 92
0,012 0	0,000 65	0,001 37	0,001 00

## 9 Test report

The test report shall include the following information:

- a) all information necessary for the identification of the sample, the laboratory and the data of analysis;
- b) the method used by reference to this International Standard;
- c) the results, and the form in which they are expressed;
- d) any unusual features noted during the determination;
- e) any operation not specified in this International Standard, or any optional operation which may have influenced the results.

## Annex A (informative)

### Examples of aluminium alloy blocks

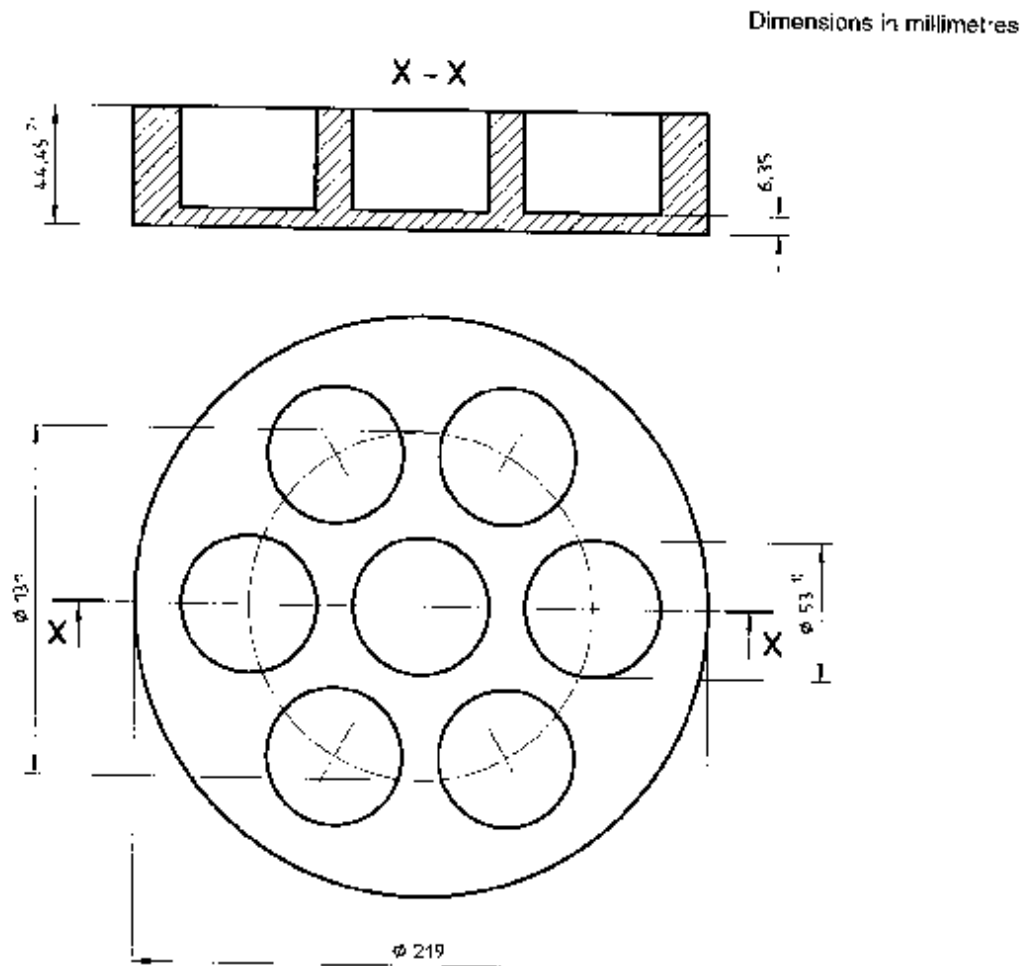

- 1) Adapt the diameter of the holes according to the diameter of the beakers used.
- 2) Holes having the same height as the surface of the solution in the beaker can be used if this is preferable.

**Figure A.1 – Example of an aluminium alloy block**

Dimensions in millimetres

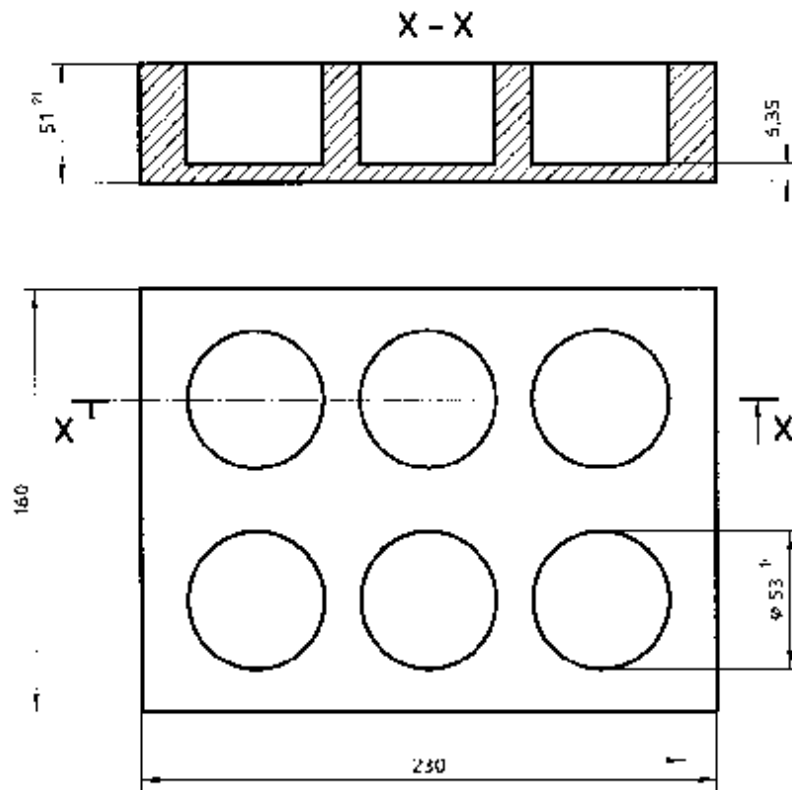

- 1) Adapt the diameter of the holes according to the diameter of the beakers used.
- 2) Holes having the same height as the surface of the solution in the beaker can be used if this is preferable.

**Figure A.2 — Example of an aluminium alloy block**

## Annex B (Informative)

### Additional information on international cooperative tests

Table 3 was derived from the results of international analytical trials carried out in 1993 on five unalloyed steel samples in six countries involving 14 laboratories.

The results of the trials were reported in document ISO/TC 17/SC 1 N 1031, March 1994.

The precision data are presented in graphical form in annex C (figure C.1).

The test samples used are listed in table B.1.

**Table B.1 — Detailed results obtained in interlaboratory tests**

Sample	Boron content, % (m/m)			Precision data		
	Certified	Found		Repeatability limit $r$	Reproducibility limits $R$ $R_0$	
		$\bar{w}_{B,1}$	$\bar{w}_{B,2}$			
JSS 003-3 (Pure iron) <sup>1)</sup>	0,000 03 <sup>2)</sup>	0,000 06	0,000 06	0,000 05	0,000 14	0,000 10
NIST 365 (Electrolytic iron)	0,000 12	0,000 13	0,000 13	0,000 05	0,000 10	0,000 06
ECRM B 097-1 (Pure iron)	0,000 3	0,000 25	0,000 24	0,000 07	0,000 15	0,000 09
CMSI 1135 (Pure Iron)	0,000 6	0,000 56	0,000 56	0,000 12	0,000 31	0,000 14
JSS 361-1 (Unalloyed steel)	0,000 9	0,000 97	0,000 96	0,000 13	0,000 34	0,000 22
$\bar{w}_{B,1}$ : general mean within a day						
$\bar{w}_{B,2}$ : general mean between days						
1) The data for sample JSS 003-3 has been omitted from the calculation of precision because the boron content of this sample lies outside the range of application of the method.						
2) Non-certified value.						

Table 4 was derived from the results of international analytical trials carried out in 1986 on eight steel samples in eight countries involving 21 laboratories.

The results of the trials were reported in document ISO/TC 17/SC 1 N 755, January 1989 (revised).

The precision data are presented in graphical form in annex C (figure C.2).

The test samples used are listed in table B.2.

Table B.2 — Detailed results obtained in interlaboratory tests

Sample	Boron content, % (m/m)			Precision data		
	Certified	Found		Repeatability limit <i>r</i>	Reproducibility limits	
		$\bar{w}_{B,1}$	$\bar{w}_{B,2}$		<i>R</i>	<i>R<sub>s</sub></i>
ECRM 283-1 <sup>1)</sup> (High speed steel)	0,000 3	0,000 26	0,000 27	0,000 13	0,000 23	0,000 22
ECRM 097-1 <sup>1)</sup> (High purity iron)	0,000 3	0,000 23	0,000 23	0,000 22	0,000 28	0,000 22
BAN 187-1 (Low alloyed steel)	0,000 4	0,000 46	0,000 48	0,000 18	0,000 29	0,000 21
BCS 456/1 (Mild steel)	0,001 5	0,001 36	0,001 35	0,000 20	0,000 56	0,000 25
BAM 284-1 (Stainless steel)	0,003 8	0,003 62	0,003 62	0,000 28	0,000 60	0,000 42
BAM 178-1 (Low alloyed steel)	0,004 1	0,004 32	0,004 31	0,000 40	0,000 54	0,000 55
JSS 175-5 (Mild steel)	0,009 0	0,009 04	0,009 09	0,000 49	0,001 4	0,000 95
BCS 459/1 (Carbon steel)	0,011 8	0,011 4	0,011 5	0,000 93	0,001 8	0,001 1
$\bar{w}_{B,1}$ : general mean within a day						
$\bar{w}_{B,2}$ : general mean between days						
1) The data for samples ECRM 283-1 and ECRM 097-1 has been omitted from the calculation of precision because the boron content of those samples lies outside the range of application of the method.						

## Annex C (informative)

### Graphical representation of precision data

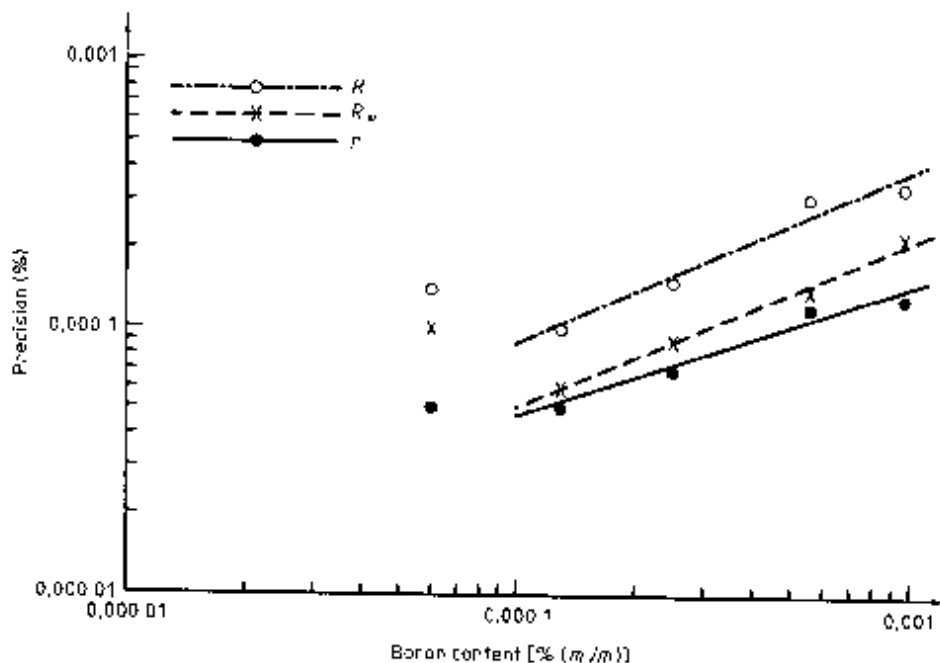

$$\lg r = 0,503 \lg \bar{w}_{B,1} - 2,346$$

$$\lg R = 0,656 \lg \bar{w}_{B,1} - 1,446$$

$$\lg R_w = 0,625 \lg \bar{w}_{B,2} - 1,792$$

where

$\bar{w}_{B,1}$  is the average boron content, expressed as a percentage by mass, obtained within a day;

$\bar{w}_{B,2}$  is the average boron content, expressed as a percentage by mass, obtained between days.

**Figure C.1 — Logarithmic relationships between boron content ( $\bar{w}_B$ ) and repeatability limit ( $r$ ) and reproducibility limits ( $R$  and  $R_w$ )**

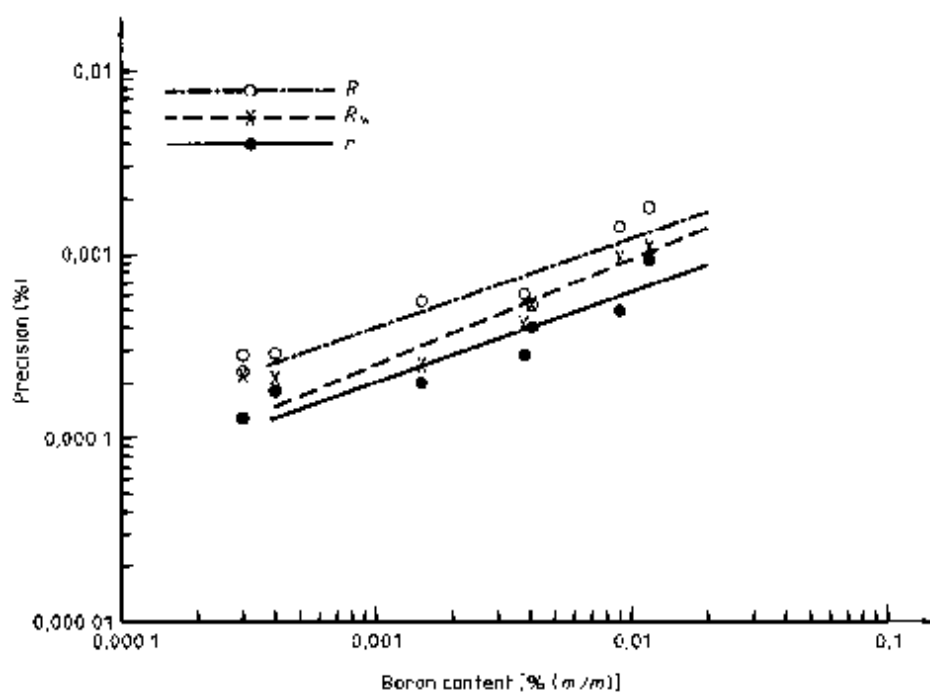

$$\lg r = 0,474 \lg \bar{w}_{B,1} - 2,275$$

$$\lg R = 0,501 \lg \bar{w}_{B,1} - 1,898$$

$$\lg R_w = 0,563 \lg \bar{w}_{B,2} - 1,909$$

where

$\bar{w}_{B,1}$  is the average boron content, expressed as a percentage by mass, obtained within a day;

$\bar{w}_{B,2}$  is the average boron content, expressed as a percentage by mass, obtained between days.

**Figure C.2 — Logarithmic relationships between boron content ( $\bar{w}_B$ ) and repeatability limit ( $r$ ) and reproducibility limits ( $R$  and  $R_w$ )**



## Annex D

### (informative)

### Additional precision tests conducted by European countries

The results of precision tests conducted by European countries are given in table D.1.

The data obtained showed a logarithmic relationship between boron content and repeatability limit ( $r$ ), and reproducibility limits ( $R$  and  $R_w$ ) of the test results, as summarized in table D.2.

**Table D.1**

Type of test sample	Boron content % (m/m)	Repeatability limit $r$	Reproducibility limits	
			$R$	$R_w$
Unalloyed steel <sup>1)</sup>	0,000 23	0,000 10	0,000 18	0,000 17
Unalloyed steel	0,001 08	0,000 15	0,000 28	0,000 32
Unalloyed steel	0,002 75	0,000 29	0,000 36	0,000 34
Unalloyed steel	0,003 15	0,000 29	0,000 36	0,000 35
Unalloyed steel	0,003 78	0,000 29	0,000 72	0,000 25
Unalloyed steel	0,008 69	0,000 37	0,001 32	0,000 73
Alloyed steel	0,000 45	0,000 13	0,000 42	0,000 18
Alloyed steel	0,004 32	0,000 27	0,000 48	0,000 42

1) Excluded from calculations of the relations of statistical parameters with boron content.

**Table D.2**

Boron content % (m/m)	Repeatability limit $r$	Reproducibility limits	
		$R$	$R_w$
0,000 5	0,000 13	0,000 28	0,000 19
0,001 0	0,000 17	0,000 36	0,000 24
0,002 0	0,000 22	0,000 45	0,000 31
0,005 0	0,000 31	0,000 63	0,000 43
0,010 0	0,000 41	0,000 80	0,000 56
0,012 0	0,000 44	0,000 85	0,000 60

$\lg r = 0,382 \lg \bar{w}_{B,1} - 2,623$   
 $\lg R = 0,352 \lg \bar{w}_{B,1} - 2,392$   
 $\lg R_w = 0,362 \lg \bar{w}_{B,2} - 2,520$

---

---

**ICS 77.080.20**

**Descriptors:** steels, chemical analysis, determination of content, boron, spectrometric method.

Price based on 15 pages

---

---