

INTERNATIONAL  
STANDARD

**ISO**  
**10143**

First edition  
1995-12-01

---

---

**Carbonaceous materials for the production  
of aluminium — Calcined coke for  
electrodes — Determination of the  
electrical resistivity of granules**

*Produits carbonés utilisés pour la production de l'aluminium — Coke  
calciné — Détermination de la résistivité électrique granulaire*



Reference number  
ISO 10143:1995(E)

## **Foreword**

ISO (the International Organization for Standardization) is a worldwide federation of national standards bodies (ISO member bodies). The work of preparing International Standards is normally carried out through ISO technical committees. Each member body interested in a subject for which a technical committee has been established has the right to be represented on that committee. International organizations, governmental and non-governmental, in liaison with ISO, also take part in the work. ISO collaborates closely with the International Electrotechnical Commission (IEC) on all matters of electrotechnical standardization.

Draft International Standards adopted by the technical committees are circulated to the member bodies for voting. Publication as an International Standard requires approval by at least 75 % of the member bodies casting a vote.

International Standard ISO 10143 was prepared by Technical Committee ISO/TC 47, *Chemistry*, Subcommittee SC 7, *Aluminium oxide, cryolite, aluminium fluoride, sodium fluoride, carbonaceous products for the aluminium industry*.

Annex A of this International Standard is for information only.

© ISO 1995

All rights reserved. Unless otherwise specified, no part of this publication may be reproduced or utilized in any form or by any means, electronic or mechanical, including photocopying and microfilm, without permission in writing from the publisher.

International Organization for Standardization  
Case Postale 56 • CH-1211 Genève 20 • Switzerland

Printed in Switzerland

# Carbonaceous materials for the production of aluminium — Calcined coke for electrodes — Determination of the electrical resistivity of granules

## 1 Scope

This International Standard specifies a method for the determination of the electrical resistivity of granular carbon (calcined or graphitized) used in the manufacture of carbon electrodes for the production of aluminium.

The measurement of electrical resistivity assists in assessing the extent of coke calcination. The electrical resistivity of the coke aggregate will influence that of the coke electrodes made from it.

In general, a more highly calcined coke will have a lower electrical resistivity if other factors such as grain size are similar.

## 2 Normative references

The following standards contain provisions which, through reference in this text, constitute provisions of this International Standard. At the time of publication, the editions indicated were valid. All standards are subject to revision, and parties to agreements based on this International Standard are encouraged to investigate the possibility of applying the most recent edition of the standards indicated below. Members of IEC and ISO maintain registers of currently valid International Standards.

ISO 6375:1980, *Carbonaceous materials for the production of aluminium — Coke for electrodes — Sampling*.

ISO 8723:1986, *Carbonaceous materials for the production of aluminium — Calcined coke — Determination of oil content — Method by solvent extraction*.

## 3 Principle

A test portion of the granular carbon is placed in a cylindrical holder which has electrical contacts at the top and bottom. A fixed pressure is applied to the test portion to ensure good electrical contact and a fixed, constant direct current is applied. The voltage drop and the height of the column of granules are measured and the electrical resistivity is calculated.

## 4 Apparatus

Ordinary laboratory apparatus, plus the following:

**4.1 Sample holder and plunger**, with removable base for cleaning as shown in figure 1.

**4.2 Length-measuring device**, capable of measuring the movement of the compression plunger to  $\pm 0,02$  mm.

**4.3 Brass reference cylinder**, having a height of  $20 \text{ mm} \pm 0,01 \text{ mm}$  and a diameter of 29 mm, used for calibrating the length-measuring device (4.2).

**4.4 Test machine**, capable of applying a constant pressure of  $3 \text{ MPa} \pm 1 \%$  to the plunger (see 4.1), giving a velocity to the plunger of not more than 50 mm/s and having a centering device for the sample holder (see 4.1).

NOTE 1 A compression-testing machine conforming to DIN 51223 [2] and capable of measuring to  $\pm 1 \%$  as defined in class 1 of DIN 51220 [1], or a deadweight arrangement, is suitable.

Dimensions in millimetres

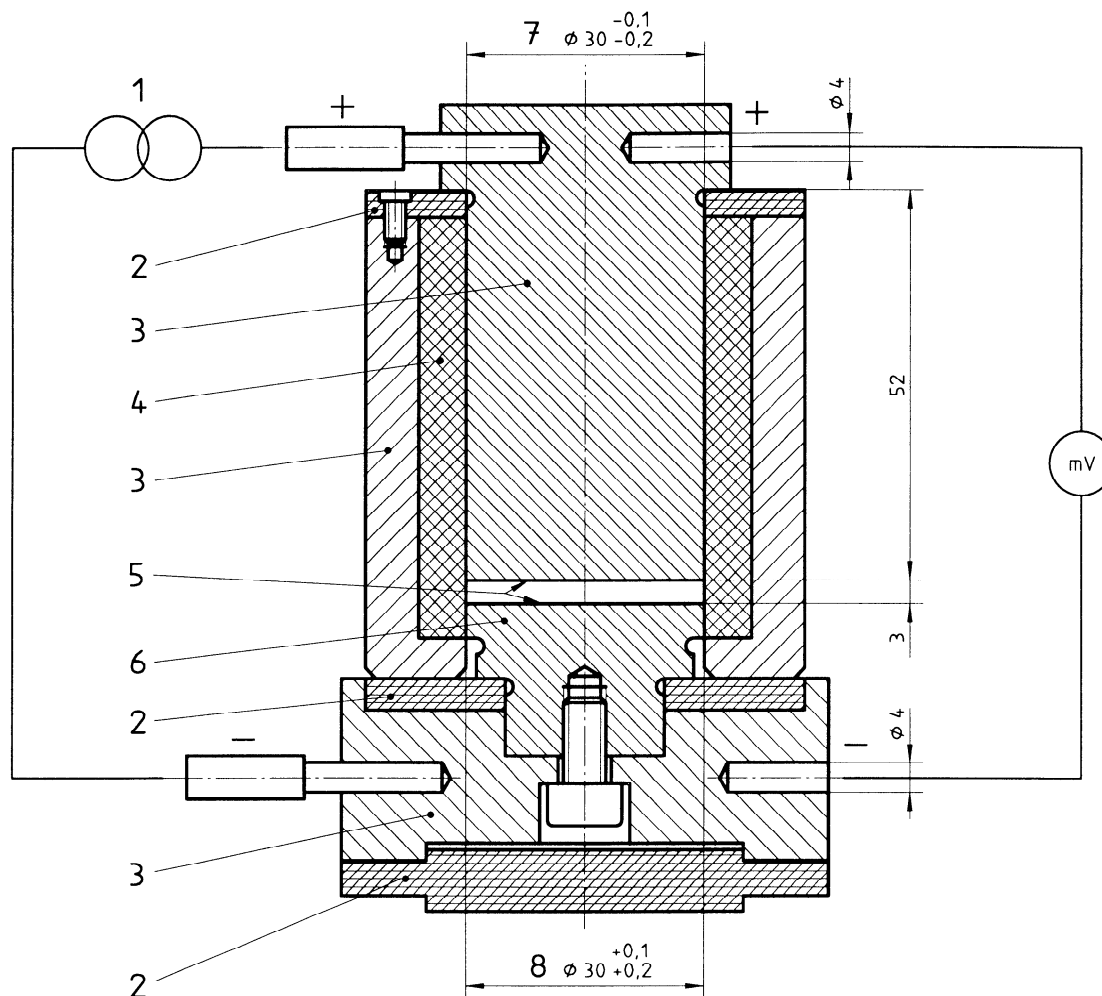
**Key**

- 1 Power supply, 1 A d.c.
- 2 PTFE
- 3 Brass
- 4 Agate
- 5 Hard-chromed surfaces
- 6 Stainless steel
- 7 Plunger
- 8 Mould

**Figure 1 — Sample holder and plunger, showing electrical connections**

**4.5 Power supply**, capable of providing a constant direct current of  $1 \text{ A} \pm 0,002 \text{ A}$ .

**4.6 Voltmeter**, capable of measuring to the nearest  $\pm 0,01 \text{ mV}$ .

**4.7 Oven**, capable of being maintained at  $120 \text{ °C} \pm 2 \text{ °C}$ .

## 5 Sampling and sample preparation

### 5.1 Sampling

Sample the coke in accordance with ISO 6375.

### 5.2 Sample preparation

Divide the sample, by sieving, into three fractions (I, IIa and III) as follows:

Fraction I	> 1,0 mm
Fraction IIa	0,5 mm to 1,0 mm
Fraction III	< 0,5 mm

Crush fraction I so that it is predominantly 0,5 mm to 1,0 mm and sieve to form fraction IIb.

Mix fractions IIa and IIb thoroughly.

Wash the sample with dichloromethane in accordance with ISO 8723.

Heat the sample to  $120\text{ °C} \pm 2\text{ °C}$  for 30 min using the oven (4.7), allow to cool in a desiccator and weigh to the nearest 0,1 g or better. Repeat the operations of heating, cooling and weighing until the difference between two successive weighings does not exceed 0,1 % of the original sample mass.

## 6 Procedure

### 6.1 Test portion

Weigh out  $15\text{ g} \pm 0,1\text{ g}$  of the mixture of fractions IIa and IIb.

### 6.2 Setting up the test machine

Place the brass reference cylinder (4.3) in the sample holder (see 4.1).

Place the sample holder with plunger (4.1) in the test machine (4.4) and apply a pressure of 3 MPa. Set the length-measuring device (4.2) to the reference level of 20 mm. Connect up the electrical wires and switch on the power supply (4.5).

Using the voltmeter (4.6), verify that the voltage drop is less than 0,02 mV.

### 6.3 Determination

Pour the test portion into the sample holder, insert the plunger and place the assembly in the test machine.

Apply a pressure of 3 MPa to the test portion and after 30 s record the voltage drop and the height of the column of granules.

### 6.4 Number of determinations

Carry out two determinations using a fresh test portion for each determination.

Clean the base and the plunger surfaces carefully after each determination.

## 7 Expression of results

Calculate the electrical resistivity  $\rho$ , expressed in microhm metres, of the calcined coke using the following equation:

$$\rho = \frac{S \times U}{I \times h}$$

where

- $S$  is the surface area, in square millimetres, of the sample holder ( $707\text{ mm}^2$  for the sample holder shown in figure 1);
- $U$  is the voltage drop, in millivolts;
- $I$  is the current applied, in amps ( $1\text{ A} \pm 0,002\text{ A}$ );
- $h$  is the height, in millimetres, of the column of granules.

Express the result as the arithmetic mean of two determinations.

## 8 Precision<sup>1)</sup>

### 8.1 Repeatability

The difference between the values of duplicate determinations, carried out in rapid succession by the same operator using the same apparatus on granules taken from the same test sample, shall not exceed the repeatability limit  $r = 3\%$ .

### 8.2 Reproducibility

The difference between the values of the average of duplicate determinations obtained by two laboratories using this method for the analysis of the same laboratory sample is not expected to exceed the reproducibility limit  $R = 5\%$ .

## 9 Test report

The test report shall include the following information:

- a) all details necessary for complete identification of the sample;
- b) a reference to this International Standard;
- c) the size distribution of the grain fraction used;
- d) the results, expressed in accordance with clause 7;
- e) details of any unusual features noted during the determination;
- f) details of any operation not included in this International Standard or in the International Standards to which reference is made, as well as any operation regarded as optional.

1) ISO 5725:1986, *Precision of test methods — Determination of repeatability and reproducibility for a standard test method by inter-laboratory tests* (now withdrawn), was used to obtain the precision data.

**Annex A**  
(informative)

**Bibliography**

- [1] DIN 51220:1976, *Werkstoffprüfmaschinen; Allgemeine Richtlinien. (Material testing machines; General directions.)*
- [2] DIN 51223:1987, *Werkstoffprüfmaschinen; Druckprüfmaschinen; Anforderungen. (Material testing machines; compression-testing machines — requirements.)*

This page intentionally left blank

---

---

**ICS 71.100.10**

**Descriptors:** extractive metallurgy, aluminium, electrodes, carbonaceous materials, carbon electrodes, granular materials, coke, tests, electrical tests, determination, electrical resistance.

Price based on 4 pages

---

---