

INTERNATIONAL STANDARD

ISO 10079-1

Second edition
1999-08-15

Medical suction equipment —

Part 1:

Electrically powered suction equipment — Safety requirements

Appareils d'aspiration médicale —

Partie 1: Appareils électriques d'aspiration — Prescriptions de sécurité

This material is reproduced from ISO documents under International Organization for Standardization (ISO) Copyright License Number IHS/ICC/1996. Not for resale. No part of these ISO documents may be reproduced in any form, electronic retrieval system or otherwise, except as allowed in the copyright law of the country of use, or with the prior written consent of ISO (Case postale 56, 1211 Geneva 20, Switzerland, Fax +41 22 734 10 79), IHS or the ISO Licensor's members.



Reference number
ISO 10079-1:1999(E)

Contents

1 Scope	1
2 Normative references	2
3 Terms and definitions	3
4 General requirements and general requirements for tests	5
5 Classification.....	5
6 Identification, marking and documents.....	5
7 Power input	7
8 Environmental conditions.....	7
9 Protection against electric shock hazards.....	8
10 Protection against mechanical hazards	9
11 Protection against hazards from unwanted or excessive radiation.....	10
12 Protection against hazards of ignition of flammable anaesthetic mixtures	10
13 Protection against excessive temperatures and other safety hazards	11
14 Accuracy of operating data and protection against hazardous output	15
15 Abnormal operation and fault conditions: environmental tests	15
16 Constructional requirements.....	17
Annexes A to L.....	25
Annex M (informative) Rationale statement.....	26
Annex N (informative) Table of typical ranges of volume for collection containers for specific uses.....	27
Annex O (informative) Lumen (passageway) size and its effects on flow.....	28

© ISO 1999

All rights reserved. Unless otherwise specified, no part of this publication may be reproduced or utilized in any form or by any means, electronic or mechanical, including photocopying and microfilm, without permission in writing from the publisher.

International Organization for Standardization
Case postale 56 • CH-1211 Genève 20 • Switzerland
Internet iso@iso.ch

Printed in Switzerland

Foreword

ISO (the International Organization for Standardization) is a worldwide federation of national standards bodies (ISO member bodies). The work of preparing International Standards is normally carried out through ISO technical committees. Each member body interested in a subject for which a technical committee has been established has the right to be represented on that committee. International organizations, governmental and non-governmental, in liaison with ISO, also take part in the work. ISO collaborates closely with the International Electrotechnical Commission (IEC) on all matters of electrotechnical standardization.

International Standards are drafted in accordance with the rules given in the ISO/IEC Directives, Part 3.

Draft International Standards adopted by the technical committees are circulated to the member bodies for voting. Publication as an International Standard requires approval by at least 75 % of the member bodies casting a vote.

International Standard ISO 10079-1 was prepared by Technical Committee ISO/TC 121, *Anaesthetic and respiratory equipment*, Subcommittee SC 8, *Suction devices for hospital and emergency care use*.

This second edition cancels and replaces the first edition (ISO 10079-1:1991), which has been technically revised.

ISO 10079 consists of the following parts, under the general title *Medical suction equipment*:

- *Part 1: Electrically powered suction equipment — Safety requirements*
- *Part 2: Manually powered suction equipment*
- *Part 3: Suction equipment powered from vacuum or pressure source*

Annexes A to L of this part of ISO 10079 refer to Appendixes A to L of IEC 60601:1988, respectively. Annexes M, N and O are for information only.

Medical suction equipment —

Part 1:

Electrically powered suction equipment — Safety requirements

1 Scope

This part of ISO 10079 specifies minimum safety and performance requirements for medical and surgical suction equipment (see Figure 1) for health care facilities such as hospitals, for domiciliary care of patients and for field and transport use.

Although such equipment may be driven by centrally powered piped vacuum systems, compressed gases and electricity, or be manually powered for a variety of applications, this part of ISO 10079 addresses only mains electricity- and battery-powered suction equipment.

NOTE See also annex M in this part of ISO 10079.

ISO 10079-1 is one of a series of International Standards based on IEC 60601-1:1988; in IEC 60601-1 (the "General Standard"), this type of International Standard is referred to as a "Particular Standard". As stated in 1.3 of IEC 60601-1:1988, the requirements of this part of ISO 10079 take precedence over those of IEC 60601-1.

The scope and object given in clause 1 of IEC 60601-1:1988 apply, except that 1.1 shall be replaced by the following:

This part of ISO 10079 is not applicable to:

- a) central power supply (by vacuum/compressed air generation), piping systems of vehicles and buildings, and wall connectors;
- b) catheter tubes, drains, curettes and suction tips;
- c) syringes;
- d) dental suction equipment;
- e) waste gas scavenging systems;
- f) laboratory suction;
- g) autotransfusion systems;
- h) passive urinary drainage;
- i) closed systems for wound drainage;
- j) gravity gastric drainage;
- k) orally operated mucous extractors;
- l) suction equipment where the collection container is downstream of the vacuum pump;
- m) equipment marked as suction unit for permanent tracheostomy;
- n) ventouse (obstetric) equipment;
- o) neonatal mucous extractors;
- p) suction equipment marked for endoscopic use only.

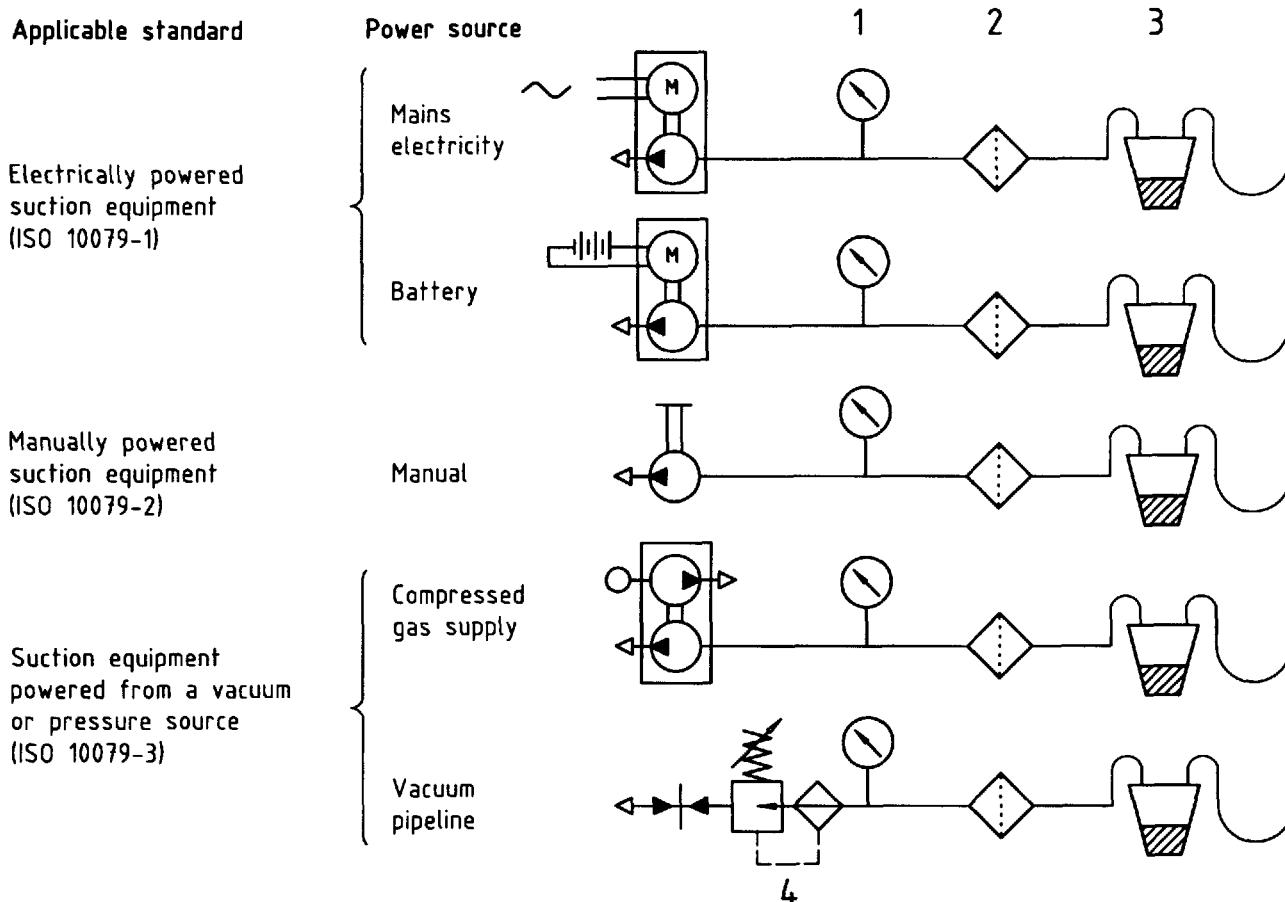

- Key**
- 1 Vacuum indicator
 - 2 Filter
 - 3 Collection container
 - 4 Vacuum regulator

NOTE 1 This part of ISO 10079 applies to mains electricity- and battery-powered suction equipment. Part 2 of ISO 10079 applies to manually powered suction equipment. Part 3 of ISO 10079 applies to suction equipment powered from a vacuum or pressure source.

NOTE 2 Components illustrated are not necessarily required by this part of ISO 10079.

NOTE 3 Suction equipment shown is an example only, and actual systems may consist of other arrangements and components not illustrated.

Figure 1 — Schematic drawing of suction equipment

2 Normative references

The following normative documents contain provisions which, through reference in this text, constitute provisions of this part of ISO 10079. For dated references, subsequent amendments to, or revisions of, any of these publications do not apply. However, parties to agreements based on this part of ISO 10079 are encouraged to investigate the possibility of applying the most recent editions of the normative documents indicated below. For undated references, the latest edition of the normative document referred to applies. Members of ISO and IEC maintain registers of currently valid International Standards.

ISO 3744:1994, *Acoustics — Determination of sound power levels of noise sources — Engineering methods for free-field conditions over a reflecting plane.*

ISO 5356-1:1996, *Anaesthetic and respiratory equipment — Conical connectors — Part 1: Cones and sockets.*

ISO 8836:1997, *Suction catheters for use in the respiratory tract.*

IEC 60079-4:1975, *Electrical apparatus for explosive gas atmospheres — Part 4: Method of test for ignition temperature.*

IEC 60529:1976, *Classification of degrees of protection provided by enclosures.*

IEC 60601-1:1988, *Medical electrical equipment — Part 1: General requirements for safety*; and Amd.1:1991 and Amd.2:1995.

IEC 60651:1979, *Sound level meters.*

IEC 60695-2-2:1980, *Fire hazard testing — Part 2: Test methods — Needle-flame test.*

3 Terms and definitions

For the purposes of this part of ISO 10079, the terms and definitions given in clause 2 of IEC 60601-1:1988 apply except that the definition given in 2.1.5 shall be replaced by the following:

2.1.5

applied part

all parts in the liquid pathway

Add to definition 2.4.3 the following:

2.4.3

safety extra-low voltage

SELV

electrical sources which are isolated (e.g. car battery) and do not require a separate transformer or converter with separate windings

For the purposes of this part of ISO 10079, the following additional terms and definitions apply.

3.1

breast pump

vacuum pump for the collection of breast milk

3.2

collection container

container in which liquids and solid particles are collected

3.3

collection container assembly

collection container and its closure with connectors for suction

3.4

drainage

removal of fluids from a body cavity or wound

3.5

end-piece

that part of the suction equipment applied to the patient which begins at the site where material is drawn in and ends at the first detachable connection

NOTE Examples of commonly used end-pieces are a Yanker sucker and a suction catheter.

3.6

exhaust opening

port or ports through which exhaust is discharged

- 3.7
filter**
device for retention of particulate matter
- 3.8
free air flow**
unrestricted flow of air through a designated inlet
- 3.9
high flow suction**
suction which produces a free air flow of 20 l/min or more
- 3.10
high vacuum**
vacuum of 60 kPa or more below atmospheric pressure
- NOTE 1 kPa = 7,50 mmHg or 4,02 inchH₂O or 10,2 cmH₂O or 10 hPa
- 3.11
inlet**
port of a component through which fluids and/or solid particles enter
- 3.12
intermediate tubing**
tubing between the collection container and the vacuum source
- 3.13
intermittent suction**
type of suction in which the negative pressure applied to the end-piece is automatically and periodically returned to atmospheric pressure
- 3.14
low flow suction**
suction which produces a free air flow less than 20 l/min
- 3.15
low vacuum**
vacuum of not more than 20 kPa below atmospheric pressure
- 3.16
medium vacuum**
vacuum of more than 20 kPa but less than 60 kPa below atmospheric pressure
- 3.17
outlet**
port of a component through which fluids and/or solid particles exit
- 3.18
overflow protection device**
system intended to prevent liquid or solid particles from entering the intermediate tubing
- 3.19
suction**
application of vacuum to remove fluids and/or solid particles
- 3.20
suction tubing**
tubing for conduction of fluids and/or solid particles between the end-piece and the collection container

3.21 thoracic drainage

drainage by application of suction to the thoracic cavity of the patient

NOTE For the purposes of this part of ISO 10079, all thoracic drainage is considered to be active.

3.22 vacuum

pressure less than atmospheric pressure

NOTE In this part of ISO 10079, vacuum is expressed as a difference from atmospheric pressure.

3.23 vacuum indicator

device for displaying the level of vacuum

3.24 vacuum pump

powered device for generating vacuum

3.25 vacuum regulator

device for controlling the maximum vacuum applied to the patient

4 General requirements and general requirements for tests

The requirements given in clauses 3 and 4 of IEC 60601-1:1988 apply, together with the following additional item:

4.6 f) Where reference is made in test methods to tubing, the tubing which is supplied or recommended by the manufacturer shall be used.

5 Classification

The classification given in clause 5 of IEC 60601-1:1988 applies.

6 Identification, marking and documents

The requirements given in clause 6 of IEC 60601-1:1988 apply, with the following additions and modifications:

6.1 e) add the following:

The address of the manufacturer, and the name and address of the supplier responsible within the region or country if the supplier is not the manufacturer.

Wherever reasonable and practicable, the device and detachable components shall be identified, where appropriate, in terms of batches, to allow the appropriate action to detect any potential risk posed by the devices and detachable components.

6.1 f) add the following:

The equipment shall be marked with a batch or serial number and also year of manufacture, to allow all parts in the functional state to be sufficiently identified to the level that appropriate action can be undertaken if a defect or hazard arises.

Replace **6.1 p)** by the following:

- 1) All equipment generating suction shall be marked with words indicating suction, and with an indication of the available level of vacuum as determined by the manufacturer. This marking shall be visible in the normal working position.

NOTE Equipment including vacuum should be marked with the designation; "high vacuum/high flow", "high vacuum/low flow", "medium vacuum/high flow", "medium vacuum/low flow", "low vacuum/high flow" or "low vacuum/low flow", as appropriate.

- 2) Low vacuum equipment with a level of vacuum which is not adjustable by the user shall be marked either with the level of vacuum which can be attained or with words indicating low vacuum.
- 3) Intermittent suction equipment shall be marked with words indicating intermittent suction. Equipment which can provide both continuous and intermittent suction shall have the mode control clearly marked.
- 4) If there is a single exhaust opening, it shall be marked with words indicating exhaust opening.
- 5) Suction equipment intended for thoracic drainage and complying with 59.8 shall be marked as such.
- 6) The inlet connection to the collection container shall be identified unless misconnection is prevented by a design feature.
- 7) If the suction equipment is intended for use in the field and/or transport and does not comply with 53.1, it shall be marked on the equipment case as not suitable for use at temperatures below ... °C or above ... °C, with the appropriate limiting temperatures marked. If no case is provided, the statement shall be marked on the equipment.

In **6.1**, add the following additional items:

- aa) Equipment containing a filter which is intended to be cleaned or changed by the user shall have wording clearly marked on the equipment, or on the filter unit, to the effect that the filter should be cleaned or changed in accordance with the manufacturer's recommendations.
- ab) The capacity of the collection container.

In **6.3 c)**, add the following:

If a progressive variation in the degree of vacuum is available, the direction of adjustment to increase vacuum shall be clearly and permanently marked.

In **6.8.1**, add the following:

The collection container capacity shall be stated in the accompanying documents.

In **6.8.2 a)**, add the following:

The instructions for use shall additionally include the following information:

- 1) instructions for operating the vacuum regulator, if supplied, and for setting the required vacuum;
- 2) the size and type of suction tubing recommended for use with the suction equipment and its means of connection to the collection container;
- 3) recommended methods for cleaning and disinfection or sterilization of all applied parts;
- 4) the method for removing the collection container for emptying;
- 5) details of the operation of any overflow protection device fitted to the collection container assembly and the usable capacity of the collection container in all the recommended inclined planes of operation;
- 6) if applicable, the method of controlling frothing in the collection container;

- 7) instructions, if applicable, for the replacement or cleaning of air filters, and for cleaning or sterilization of the filter housing;
- 8) on performance as either
 - i) the type of equipment, e.g. medical suction, high vacuum, high flow,
 - ii) the level of vacuum and flow obtainable,
 - iii) the vacuum and air flow characteristics obtainable from the equipment as required by 6.1 p) 1), 2) or 3), as appropriate.
- 9) instructions to inspect suction tubing, collection containers and any other components that are subject to wear or damage;
- 10) a statement advising removal and servicing of the equipment if liquid or solid has been drawn into the vacuum pump;

NOTE In some cases, this may require servicing by the manufacturer or his authorized agent.
- 11) if applicable, a statement that suction ceases when the overfill protection device operates, and the method of correcting this situation;
- 12) recommendations for cleaning and/or disinfection of the outer casing;
- 13) instructions for cleaning and sterilization or disinfection of reusable suction tubing;
- 14) instructions for sterilizing or disinfecting any part of a filter assembly which is reusable;
- 15) guidance for the intended use and limitations of the equipment, including whether or not the equipment is intended for use within a health care facility, for domiciliary use, or for field and/or transport use.

7 Power input

The requirements given in clause 7 of IEC 60601-1:1988 apply.

8 Environmental conditions

8.1 Basic safety categories

Appendix A.1.2 of IEC 60601-1:1988 applies (see Amendment 2).

8.2 Removable protective means

Replaced by 6.1 z) of IEC 60601-1:1988.

8.3 Environmental conditions

The requirements given in clause 10 of IEC 60601-1:1988 apply, with the following modification.

Replace **10.2.1 a)** with the following:

- a) An ambient temperature range of + 5 °C to + 35 °C.

For field and/or transport use, environmental conditions shall be as specified in 4.10 and clause 10 of IEC 60601-1:1988.

8.4 Special measures with respect to safety

Clauses 11 and 12 of IEC 60601-1:1988 are not used.

9 Protection against electric shock hazards

9.1 General

The requirements given in clause 13 of IEC 60601-1:1988 apply.

9.2 Requirements related to classification

The requirements given in clause 14 of IEC 60601-1:1988 apply.

9.3 Limitation of voltage and/or energy

The requirements given in clause 15 of IEC 60601-1:1988 apply.

9.4 Enclosures and protective covers

The requirements given in clause 16 of IEC 60601-1: 1988 apply, together with the following additional item:

16 h) The housing shall be constructed of fire-retarding material which withstands the needle-flame test specified in IEC 60695 2-2 when the flame is applied to any point on the inside or outside surface of the housing for 20 s.

9.5 Separation

The requirements given in clause 17 of IEC 60601-1:1988 apply, except as follows:

Replace item **17 c)** by the following:

For mains-powered equipment, accessible unearthed conductive parts shall not be connected to any part of the applied part.

Compliance shall be checked by applying the normal operating voltage and frequency between any part of the applied part and accessible unearthed conductive paths.

Leakage current shall not exceed 5 mA for Type B or BF equipment and 0,05 mA for Type CF equipment.

Measurements shall be made with the applied part filled with saline solution containing 9 g/l sodium chloride until the overflow protection device operates or until saline solution emerges from the exhaust opening. For the purposes of the test for Type B or BF equipment, an electrically isolated conductive cap on a collection container is not considered to be part of the accessible unearthed conductive path.

9.6 Protective earthing, functional earthing and potential equalization

The requirements given in clause 18 of IEC 60601-1:1988 apply.

9.7 Continuous leakage currents and patient auxiliary currents

The requirements given in clause 19 of IEC 60601-1:1988 apply, together with the following addition:

In **19.4 h)**, add the following additional item:

- 12) Measurement shall be made with any overflow protection device operative. Fluid shall be drawn through a suction catheter immersed in a container filled with saline solution containing 9 g/l sodium chloride, until the overflow protection device operates or until saline solution emerges from the exhaust opening. Measurement shall be made from the saline solution in the container.

9.8 Dielectric strength

The requirements given in clause 20 of IEC 60601-1:1988 apply.

10 Protection against mechanical hazards

10.1 Mechanical strength

The requirements given in clause 21 of IEC 60601-1:1988 apply, together with the following additional requirement:

Equipment intended for field and/or transport use shall meet the requirements for flow and vacuum of this part of ISO 10079 after being dropped from a height of 1 m onto a concrete floor in the worst-case mode.

10.2 Moving parts

The requirements given in clause 22 of IEC 60601-1:1988 apply.

10.3 Surfaces, corners and edges

The requirements given in clause 23 of IEC 60601-1:1988 apply.

10.4 Stability in normal use

The requirements given in clause 24 of IEC 60601-1:1988 apply.

10.5 Expelled parts

The requirements given in clause 25 of IEC 60601-1:1988 apply.

10.6 Vibration and noise

The requirements given in clause 26 of IEC 60601-1:1988 shall be replaced by the following requirements:

26.1 Low vacuum equipment (see 59.7 and 59.8)

26.1.1 In normal use the maximum A-weighted sound pressure level (steady or peak value) of low vacuum/low flow and low vacuum suction equipment including equipment for thoracic drainage shall not exceed 60 dB.

Compliance shall be checked by the test given in 26.1.2.

26.1.2 Test the suction equipment with the inlet opened to the atmosphere and also with the inlet occluded.

Place the microphone of a sound level meter complying with the requirements for a type I instrument specified in IEC 60651 at the position of maximum sound pressure level in the horizontal plane passing through the geometric centre of the suction equipment at a radius of 1 m. The measured sound pressure level shall not exceed the specified value.

For this test, the suction equipment shall be operated over its normal working range of flowrate including the maximum flowrate recommended by the manufacturer. Measurements shall be taken using the frequency-weighting characteristic A and the time-weighting characteristic S on the sound level meter. The measurements shall be taken in a free field over a reflecting plane as specified in ISO 3744.

The A-weighted background level of extraneous noise shall be at least 10 dB below that measured during the test.

26.2 Equipment other than that specified in 26.1.

In normal use, the maximum A-weighted sound pressure level (steady or peak value) of equipment other than the low vacuum equipment specified in 26.1 shall not exceed 70 dB.

Compliance shall be checked by the test given in 26.1.2.

10.7 Pneumatic and hydraulic power

The requirements given in clause 27 of IEC 60601-1:1988 do not apply, as they are not relevant to suction equipment.

10.8 Suspended masses

The requirements given in clause 28 of IEC 60601-1:1988 apply.

11 Protection against hazards from unwanted or excessive radiation

11.1 X-radiation

The requirements given in clause 29 of IEC 60601-1: 1988 apply.

11.2 Alpha, beta, gamma, neutron radiation and other particle radiation

The requirements given in clause 30 of IEC 60601-1:1988 apply.

11.3 Microwave radiation

The requirements given in clause 31 of IEC 60601-1:1988 apply.

11.4 Light radiation (including lasers)

The requirements given in clause 32 of IEC 60601-1:1988 apply.

11.5 Infra-red radiation

The requirements given in clause 33 of IEC 60601-1:1988 apply.

11.6 Ultraviolet radiation

The requirements given in clause 34 of IEC 60601-1:1988 apply.

11.7 Acoustical energy (including ultra-sonics)

The requirements given in clause 35 of IEC 60601-1:1988 apply.

11.8 Electromagnetic compatibility

The requirements given in clause 36 of IEC 60601-1:1988 apply.

12 Protection against hazards of ignition of flammable anaesthetic mixtures

12.1 Locations and basic requirements

The requirements given in clause 37 of IEC 60601-1:1988 apply.

12.2 Marking, accompanying documents

The requirements given in clause 38 of IEC 60601-1:1988 apply.

NOTE See also annex M in this part of ISO 10079.

12.3 Common requirements for Category AP and Category APG equipment

NOTE The abbreviations "AP" and "APG" stand for "anaesthetic-proof" and "anaesthetic-proof category G" respectively.

The requirements given in clause 39 of IEC 60601-1:1988 apply.

12.4 Requirements and tests for Category AP equipment, parts and components thereof

The requirements given in clause 40 of IEC 60601-1:1988 apply.

12.5 Requirements and tests for Category APG equipment, parts and components thereof

The requirements given in clause 41 of IEC 60601-1:1988 apply.

NOTE See also annex M in this part of ISO 10079.

13 Protection against excessive temperatures and other safety hazards

13.1 Excessive temperatures

The requirements given in clause 42 of IEC 60601-1:1988 apply.

13.2 Fire prevention

Clause 43 of IEC 60601-1:1988 applies, with the following addition:

In order to reduce the risk to patients, other persons or the surroundings due to fire, ignitable material, under normal and single fault conditions, shall not at the same time be subjected to conditions in which the temperature of the material is raised to its minimum ignition temperature; and an oxidant is present.

The minimum ignition temperature shall be determined in accordance with IEC 60079-4 using the oxidizing conditions present under normal and single fault conditions.

Compliance shall be checked by determining the temperature to which the material is raised under normal and single fault conditions.

If sparking can occur under normal or single fault conditions, the material subjected to the energy dissipation of the spark shall not ignite under the oxidizing conditions present.

Compliance shall be checked by observing if ignition occurs under the most unfavorable combination of normal conditions with a single fault.

13.3 Overflow, spillage, leakage, humidity, ingress of liquids, cleaning, sterilization and disinfection

The requirements given in clause 44 of IEC 60601-1:1988 apply, with the following additions and modifications:

In **44.2**, add the following:

Means shall be provided to prevent inadvertent contamination of the pump.

When the collection container is full, suction equipment shall either continue to operate and meet the requirements of the relevant subclauses of clause 59 or shall have an overflow device to prevent liquids entering the intermediate tubing downstream of the collection container.

If the suction equipment is fitted with an overflow device, suction shall cease when the overflow device operates and not more than 5 ml of liquid shall pass downstream of the overflow device. If the overflow device is integral with the collection container, it shall not activate until at least 90 % of the stated collection capacity has been reached.

Compliance shall be checked by the following test.

Connect the overflow device according to the manufacturer's instructions. Set the suction equipment to maximum free air flow and draw water at $(23 \pm 3) ^\circ\text{C}$ into the system until the overflow protection device is activated. Run the equipment for a further 2 min. Measure the volume of water which has passed the overflow device. If the overflow device is integral with the collection container, measure the volume collected in the collection container.

Test suction equipment intended for reuse after 30 cycles of cleaning and disinfection or sterilization as recommended by the manufacturer.

Replace **44.3** by the following :

The suction equipment shall be so constructed that, in the event of spillage of liquids, no safety hazard shall result.

Compliance shall be checked by the following test.

Place the suction equipment in the least favourable position of normal use and subject it for 30 s to an artificial rainfall of 3 mm/min falling vertically from a height of 0,5 m above the top of the equipment.

Immediately after the 30 s exposure, remove visible moisture from the body of the equipment. The suction equipment shall meet the relevant dielectric strength tests specified in 20.1 to 20.4 of IEC 60601-1:1988 and meet the appropriate requirements for vacuum and flow specified in 16.6 of this part of ISO 10079.

Battery-operated transportable suction equipment intended for use in the field shall meet the requirements of 59.10 after exposure to water as specified in 8.3 of IEC 60529:1976 when in the carrying mode and position as recommended by the manufacturer.

In **44.4**, add the following:

1) Collection containers for general use

For collection containers intended for single use, the leakage of air into the collection container assembly shall not exceed 200 ml/min, if the collection container is intended for suction with a free air flow of more than 1 l/min. The pressure increase shall be less than $3,3 \text{ kPa/V}$, where V is the volume in litres, of the collection container.

A collection container assembly intended for reuse shall comply with the above requirement, before and after being subjected to 30 cycles of cleaning and disinfection or sterilization as recommended by the manufacturer.

Compliance shall be checked by the following test.

Evacuate the collection container to 40 kPa below atmospheric pressure. Close off the vacuum source, and observe the pressure increase within 10 s. (See Figure 2 for a typical test apparatus.)

NOTE A typical collection container will have a pneumatic compliance of approximately 10 ml/kPa per litre volume. A leakage of 200 ml/min corresponds to 33,3 ml per 10 s which would result in a pressure increase of $33,3/10 = 3,33 \text{ kPa per } 10 \text{ s}$.

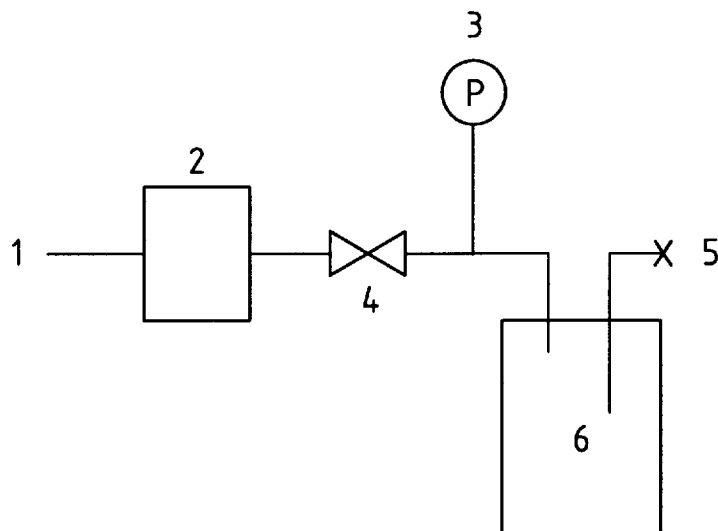
**Key**

- 1 Vacuum source
- 2 Vacuum regulator
- 3 Vacuum indicator accurate to 0,5 kPa between 30 kPa and 50 kPa below atmospheric pressure
- 4 On/off valve
- 5 Closed to atmosphere
- 6 Test collection container

Figure 2 — Typical test apparatus for evaluating leakage of collection container for general use

2) Collection containers intended for use in a thoracic drainage system.

The leakage of air into a collection container in a thoracic drainage system shall not exceed 4 ml/min. For reusable collection containers, the test shall be applied before and after the container has been subjected to 30 cycles of cleaning and disinfection or sterilization as recommended by the manufacturer.

Compliance shall be checked by the following test.

Set the vacuum regulator to 15 kPa below atmospheric pressure. Open the valve and allow the container to reach the set vacuum. Note the number of escaping bubbles escaping into the water bottle over a period of 10 s. (See Figure 3 for a typical test apparatus).

NOTE Three bubbles escaping in 10 s is approximately equivalent to a leakage of 4 ml/min.

In 44.6, add the following:

Remote foot switches with electrical switching parts shall be of watertight construction.

Compliance shall be checked by the following test.

Completely immerse the foot switch in water to a depth of 150 mm for a period of 30 min. While immersed, connect the foot switch in a circuit corresponding to its normal use and actuate it 50 times. Inspect the switch to verify that there has been no ingress of water. The foot switch shall meet the relevant requirements for dielectric strength specified in clause 20 of IEC 60601-1:1988.

Dimension in millimetres

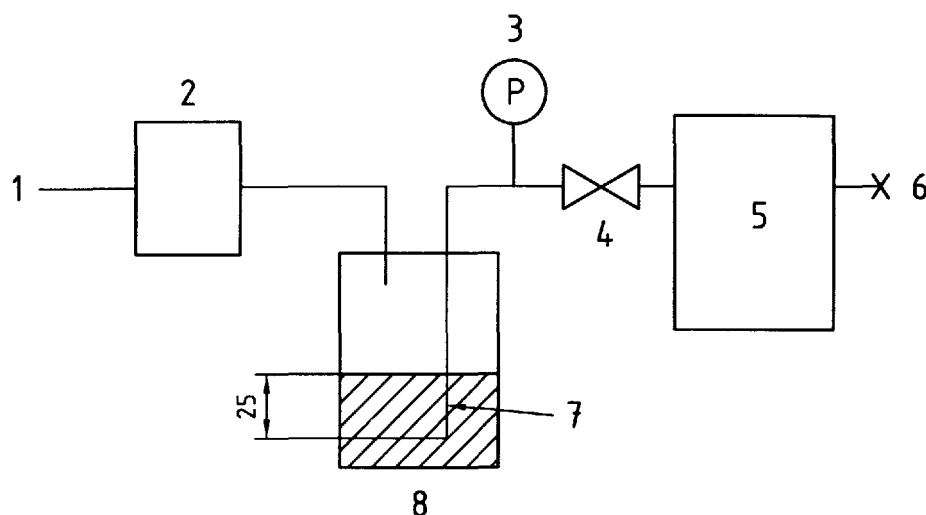

Key

- 1 Vacuum source
- 2 Vacuum regulator
- 3 Vacuum indicator accurate to 2,5 % maximum scale value
- 4 On/off valve
- 5 Test component or system
- 6 Closed to atmosphere
- 7 Tube, 6 mm inside diameter square cut
- 8 Water bottle

Figure 3 — Typical test apparatus for evaluating leakage of collection container designated for use in thoracic drainage system

In 44.7, add the following:

Filters within the applied part before the vacuum pump shall be either disposable or capable of being resterilized.

Suction equipment containing filters intended for reesterilization shall be capable of complying with the appropriate vacuum and flow requirements specified in 16.6 of this part of ISO 10079 after the filters have been subjected to 30 cycles of sterilization as recommended by the manufacturer.

13.4 Pressure vessels and parts subject to pressure

The requirements given in clause 45 of IEC 60601-1:1988 apply.

13.5 Human errors

Clause 46 of IEC 60601-1:1988 shall be replaced by the following requirements:

- a) For the purposes of this part of ISO 10079, vacuum is regarded as a medical gas.
- b) It shall not be possible to connect any tubing to the exhaust opening, if present.

There shall not be any connection point provided for positive pressure.

Compliance shall be checked by inspection.

- c) The direction of flow shall be clearly and permanently marked.

NOTE 1 Connections which are flow-sensitive (direction-specific) to the collection container should be designed to avoid misconnection.

NOTE 2 Incorrect connections have frequently been a cause of spillover into a vacuum source.

- d) Flow through the suction equipment, including battery-powered equipment, shall not be reversed if the input power leads are transposed.

Compliance shall be checked by transposing the input power leads and switching on the suction equipment.

- e) If any part of the suction equipment can be disassembled by the operator, then it shall not be possible to reassemble it in a manner which allows creation of positive pressure instead of vacuum at the applied part.

Compliance shall be checked by inspection.

13.6 Electrostatic charges

Clause 47 of IEC 60601-1:1988 is not used.

13.7 Materials in applied parts in contact with the body of the patient

Clause 48 of IEC 60601-1:1988 is not used.

13.8 Interruption of the power supply

The requirements given in clause 49 of IEC 60601-1:1988 apply, with the following modification:

Replace **49.2** by the following:

Interruption and restoration of the power supply to the suction equipment shall not cause any hazard, and the vacuum and flowrate shall not vary by more than 10 % from the set value.

Compliance shall be checked by the following test.

With the suction equipment operating in normal condition and with the vacuum set to half the maximum vacuum, interrupt the power supply. After a period of 5 min, reconnect the power supply and switch on the suction equipment. After 30 s, measure the vacuum and flowrate.

14 Accuracy of operating data and protection against hazardous output

14.1 Accuracy of operating data

Clause 50 of IEC 60601-1: 1988 is not used.

14.2 Protection against hazardous output

The requirements given in clause 51 of IEC 60601-1:1988 apply, together with the following additional subclause:

51.5 For the purposes of this part of ISO 10079, output includes vacuum and suction flow.

15 Abnormal operation and fault conditions: environmental tests

15.1 Abnormal operation and fault conditions

The requirements given in clause 52 of IEC 60601-1:1988 apply, together with the following additional subclauses:

52.6 Mains-powered high vacuum/high flow suction equipment and low vacuum suction equipment shall be so constructed that in prolonged normal use neither electrical nor mechanical failure will impair the performance as specified in this part of ISO 10079.

Except for equipment intended for use in transport or in the field, when the requirement of 52.8 shall apply, compliance shall be checked by the test given in 52.7.

52.7 Carry out the test at an ambient temperature of $(22 \pm 3) ^\circ\text{C}$. Connect the suction equipment to a supply mains having a voltage 1,10 times the maximum rated voltage. Operate the equipment for 240 h continuously with alternating total occlusion and free air flow for 15 s. Ensure that any thermal cut-out does not operate during the test.

Do not replace any components during the tests.

After the completion of the test cycles, the suction equipment shall comply with all the requirements of this part of ISO 10079.

52.8 Mains-powered suction equipment intended for use in transport or in the field shall be so constructed that in prolonged normal use neither electrical nor mechanical failure will impair the performance.

Compliance shall be checked by the following test performed at $(40 \pm 3) ^\circ\text{C}$ and $(85 \pm 5) \%$ relative humidity.

Connect the suction equipment to a supply voltage. Operate for 1 h continuously with alternating total occlusion and free air flow for 15 s. Ensure that any thermal cut-out does not operate during the test.

After completion of the test cycles, the equipment shall comply with all the requirements of this part of ISO 10079.

15.2 Environmental tests

The requirements given in clause 53 of IEC 60601-1:1988 apply, together with the following additional subclauses:

53.1 Except if marked in accordance with modified item 6.1 p) (see clause 6 of this part of ISO 10079), suction equipment intended for field and/or transport use shall meet the performance requirements specified in 59.5, 59.6, 59.7, 59.8, 59.9 or 59.10, as appropriate, over a range of high and low temperatures, both in storage and during use.

Compliance shall be checked by the tests given in 53.2, 53.3, 53.4 and 53.5.

53.2 For high temperature storage, place the suction equipment in an environmental chamber, maintained at a temperature of $(60 \pm 5) ^\circ\text{C}$ and at relative humidity of between 40 % and 70 %, for a period of not less than 4 h or until the test system stabilizes. At the end of this period, remove the suction equipment from the chamber and allow it to stand at a temperature of between $18 ^\circ\text{C}$ and $22 ^\circ\text{C}$ and at relative humidity of between 40 % and 70 %. Allow the suction equipment to stabilize for 4 h. At the end of this period, test the suction equipment for compliance with the requirements specified in 53.1.

53.3 For low temperature storage, place the suction equipment in an environmental chamber, maintained at a temperature of $(-40 \pm 5) ^\circ\text{C}$, for a period of at least 4 h or until the test system stabilizes. At the end of this period, remove the suction equipment from the chamber and allow it to stand at a temperature of between $18 ^\circ\text{C}$ and $22 ^\circ\text{C}$. Allow the suction equipment to stabilize for 4 h. At the end of this period, test the suction equipment for compliance with the requirements specified in 53.1.

53.4 For high temperature operation, place the suction equipment in an environmental chamber, maintained at a temperature of $(50 \pm 2) ^\circ\text{C}$ with a relative humidity of at least 95 %, for at least seven days. At the end of this period, remove the suction equipment from the chamber and allow it to stand at a temperature between $18 ^\circ\text{C}$ and $22 ^\circ\text{C}$ and at relative humidity of between 40 % and 70 %. Within 5 min, operate and test the suction equipment for compliance with the requirements specified in 53.1.

53.5 For low temperature operation, place the suction equipment in an environmental chamber, maintained at a temperature of $(-18 \pm 2) ^\circ\text{C}$ for 4 h or until the test system stabilizes. At the end of this period, remove the suction equipment from the chamber and allow it to stand at a temperature between $18 ^\circ\text{C}$ and $22 ^\circ\text{C}$ and a relative humidity of between 40 % and 70 %. Within 5 min, operate and test the suction equipment for compliance with the requirements specified in 53.1.

If suction equipment intended for transport and/or field use does not comply with the above requirements for high or low temperature operation, it shall be retested at less severe temperatures until it complies with the performance requirements. These limiting temperatures shall be marked as specified in item 6.1 p) 7) of this part of ISO 10079.

16 Constructional requirements

16.1 General

The requirements given in clause 54 of IEC 60601-1:1988 apply, together with the following additional subclause:

54.4 Suction equipment shall not be capable of administering positive pressure.

16.2 Enclosures and covers

Clause 55 of IEC 60601-1:1988 is not used.

16.3 Components and general assembly

The requirements given in clause 56 of ISO 60601-1:1988 apply with the following additions or modifications:

In **56.1**, add an additional item as follows:

- g) For equipment intended for field use,
 - 1) the dimensions shall be such that the equipment, including the carrying case or frame, if present, complete with contents shall pass through a rectangular opening having dimensions 600 mm × 300 mm,
 - 2) the mass of the equipment complete with carrying case, frame and accessories, if present, shall not exceed 6 kg.

NOTE Suction equipment is often combined with resuscitation equipment, which may make it impossible to define a mass for suction equipment alone. In these circumstances this item may not apply, but all equipment intended for field use should be as light-weight as possible.

In **56.3 b)**, add the following:

Connections for the suction tubing and the intermediate tubing shall be so designed as to minimize the risk of wrong assembly when all parts are mated.

Compliance shall be checked by inspection.

In **56.5**, add the following:

- 1) If suction equipment is intended to limit the vacuum to a set level, the specified vacuum level shall not be exceeded.
- 2) Suction equipment intended for thoracic drainage shall not develop a pressure in excess of 1 kPa at the patient inlet with a free air flowrate of 10 l/min. Compliance shall be checked by the following test.

Attach the patient inlet of the thoracic drainage system set up for normal use according to the manufacturer's recommendations (see Figure 4). Adjust the pressure source to produce a free air flowrate of 10 l/min and measure the pressure at the patient inlet.

NOTE For suction equipment fitted with an overfill protection device, protective means should be available to prevent foam passing downstream into the vacuum pump.

Dimensions in millimetres

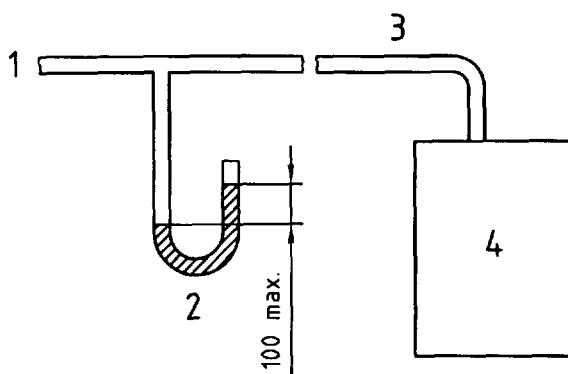

Key

- 1 Pressure source with a flowrate of 10 l/min
- 2 Water manometer
- 3 Patient tube
- 4 Thoracic drainage system

Figure 4 — Typical test apparatus for evaluating thoracic drainage system performance

In 56.8, add the following:

- 1) A vacuum regulator with a variable control shall have a vacuum indicator displaying the vacuum on the patient side of the vacuum regulator.
- 2) Analog displays shall have graduations not less than 2 mm apart, with each graduation representing not more than 5 % of the full-scale value.
- 3) Digital displays shall display vacuum at intervals of not greater than 2 % of the full-scale value. The maximum vacuum for which the equipment is designed shall be marked prominently on the display case or immediately adjacent to it.
- 4) All marking on the vacuum indicator shall be legible to an operator having visual acuity, corrected if necessary, of at least 1,0 positioned 1 m from the vacuum indicator at an illuminance of 215 lx of white (simulated day-) light.
- 5) The full scale of analog vacuum indicators shall be not more than 200 % of the maximum designed negative pressure of the suction equipment.
- 6) Except for equipment intended for field and/or transport use, suction equipment shall be fitted with a vacuum indicator.
- 7) A vacuum indicator, when required, shall be installed between the vacuum source and collection container to indicate the applied vacuum.
- 8) Vacuum indicators for suction equipment intended for thoracic drainage shall have an accuracy of ± 5 % of the full-scale value in the middle three-fifths of the indicator range.

NOTE Movement of a rotary vacuum indicator should be anticlockwise for an increase in vacuum.

- 9) Vacuum indicators for use with high vacuum suction equipment shall have accuracy within ± 5 % of the full-scale value.

In 56.11, add the following to item b)

The force required to actuate a foot switch shall be not less than 10 N and not more than 50 N.

Compliance shall be checked by applying a slowly increasing force to the switch and recording the pressure at which the switch actuates.

Add the following subclauses:

56.12 Inlet port of collection container

The inlet port of the collection container shall have a fluid pathway of not less than 6 mm internal diameter. In addition, the inlet port shall not be compatible with any of the conical connectors specified in ISO 5356-1.

NOTE 1 Suction performance may be markedly affected by the length and diameter of the suction tubing. An indication of the magnitude of this effect is given in annex P.

NOTE 2 Because of the risk of misconnection, the internal diameter of the inlet port of the collection container should not be greater than 14 mm.

NOTE 3 Special surgical situations such as suction lipectomy and suction curettage may require suction tubing and connectors of a larger bore.

56.13 Suction tubing

Suction tubing supplied with the suction equipment shall have a minimum length of 1,3 m, unless intended for field and/or transport use, in which case it shall comply with 56.14. The degree of collapse of the tubing shall be less than 0,5 throughout its entire length when subjected to the maximum vacuum stated by the manufacturer or, if the maximum vacuum is not stated, to a vacuum of 60 kPa below atmospheric pressure.

Compliance shall be checked by the test described in 56.14.

Suction catheters, if supplied or recommended by the manufacturer, shall comply with ISO 8836:1997.

56.14 Test method

At a temperature of 20 °C to 25 °C, uncoil the suction tubing to its full length and plug one end to prevent any air flow through it. Measure the inside and outside diameters of the suction tubing.

Attach a vacuum source to the other end of the suction tubing as shown in Figure 5 and adjust the level of vacuum to the maximum stated by the manufacturer, if applicable. If there is no disclosed maximum, adjust the vacuum to 60 kPa below atmospheric pressure. Hold the vacuum for 5 min.

Measure the outside diameter of the suction tubing along its entire length with calipers at approximately every 10 % of the length including any visible regions of collapse. Calculate the degree of collapse of the tubing from the following formula for each measurement point.

Degree of collapse = (OD Initial – OD Test)/ID Initial

Repeat the test while the suction tube is loosely coiled around a cylinder of diameter 100 mm.

NOTE Narrow grooves may be cut in the cylinder to aid caliper measurement.

The degree of collapse shall not exceed 0,5 in either test.

For equipment intended for field and/or transport use and intended to operate from the floor, the length of suction tubing shall be such that the end-piece can be positioned at least 1,3 m above the floor.

Compliance shall be checked by inspection.

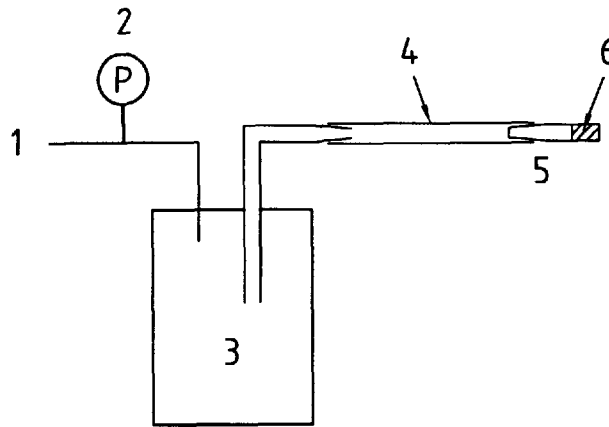

Key

- 1 Vacuum source
- 2 Vacuum indicator
- 3 Container
- 4 Tubing
- 5 Funnel connection
- 6 Plug

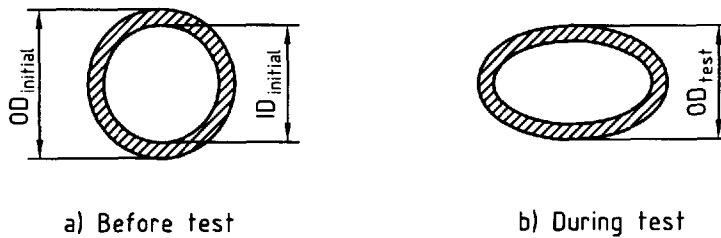

Figure 5 — Test apparatus for suction tubing collapse

16.4 Mains parts, components and layout

The requirements given in clause 57 of IEC 60601-1:1988 apply.

16.5 Protective earth terminals

The requirements given in clause 58 of IEC 60601-1:1988 apply.

16.6 Construction and layout

The requirements given in clause 59 of IEC 60601-1:1988 apply, together with the following additional subclauses:

59.5 Mains-operated transportable high vacuum/high flow equipment

Equipment intended for use in health care facilities or for domiciliary use and marked "high vacuum/high flow" shall develop within 10 s a vacuum of at least 60 kPa below atmospheric pressure in a 2 l collection container at the inlet of the collection container, and a free air flow into the collection container (without suction tubing fitted) of not less than 20 l/min.

Compliance shall be checked with the collection container empty. If the collection container has a usable volume of less than 2 l, an additional volume shall be added to make up a total of 2 l. If the collection container has a usable volume of 2 l or more, the equipment shall be tested as supplied.

59.6 Medium vacuum equipment

Equipment marked medium vacuum shall develop a vacuum not greater than 60 kPa below atmospheric pressure.

NOTE Medium vacuum for breast pumps should not exceed 33 kPa below atmospheric pressure.

Compliance shall be checked by the following test.

With the vacuum regulator set at maximum and the supply voltage at the rated voltage, switch on the suction equipment. Connect a vacuum indicator to the equipment and note the maximum vacuum attained.

59.7 Low vacuum/low flow equipment (drainage)

Equipment marked "low vacuum/low flow " shall have a continuous free air flow of between 0,5 l/min and 10 l/min and a vacuum of not more than 20 kPa below atmospheric pressure.

Compliance shall be checked with the collection container(s) empty, as follows:

- a) Switch on the equipment with the vacuum regulator adjusted to the maximum vacuum.
- b) Occlude the inlet to the collection container.
- c) Note the maximum vacuum obtained within 10 min.
- d) Open the inlet and attach to it a flowmeter with a resistance of < 0,1 kPa at 25 l/min. Note the mean free air flow, when stable conditions are reached.

59.8 Low vacuum equipment (thoracic drainage)

Equipment marked "thoracic drainage" intended for use in adults shall produce a free air flow of not less than 15 l/min at the inlet of the collection container, and the level of vacuum developed shall not exceed 20 kPa below atmospheric pressure. It shall be possible to set the level of vacuum to between 2 kPa and 20 kPa below atmospheric pressure.

NOTE For most situations the level of vacuum developed should not exceed 7 kPa below atmospheric pressure. However, in some situations, for example broncho-pleura fistula, higher flowrates such as 25 l/min may be required, and the ability to generate more vacuum and higher flows is desirable.

Equipment marked "thoracic drainage" shall be adjustable to a static vacuum of 7 kPa below atmospheric pressure. Such equipment shall produce a free air flowrate of at least 15 l/min, and shall be capable of developing, within 5 s, 95 % of the set vacuum when connected to a closed system of 4,5 l total capacity.

Compliance shall be checked by inspection and by the following test, with the collection container(s) empty.

- a) Connect the suction inlet of the equipment if necessary to a collection container(s) to bring the total collection container capacity to be evacuated to 4,5 l \pm 0,1 l.
- b) Occlude the inlet to the collection container(s).
- c) With the vacuum regulator set to between 6,6 kPa and 7,4 kPa below atmospheric pressure, switch on the equipment.
- d) Note the time taken for the reading on the vacuum indicator to increase from zero to 95 % vacuum. Note the final level of vacuum.
- e) Open the inlet and, using 2 m of flexible hose having an inside diameter of 8 mm, attach an underwater seal having an inlet of 10 mm inside diameter, positioned so that the end is 50 mm below the level of the water. Connect a low-resistance flowmeter immediately before the underwater seal, as shown in Figure 6, and measure the free air flowrate.

Dimensions in millimetres

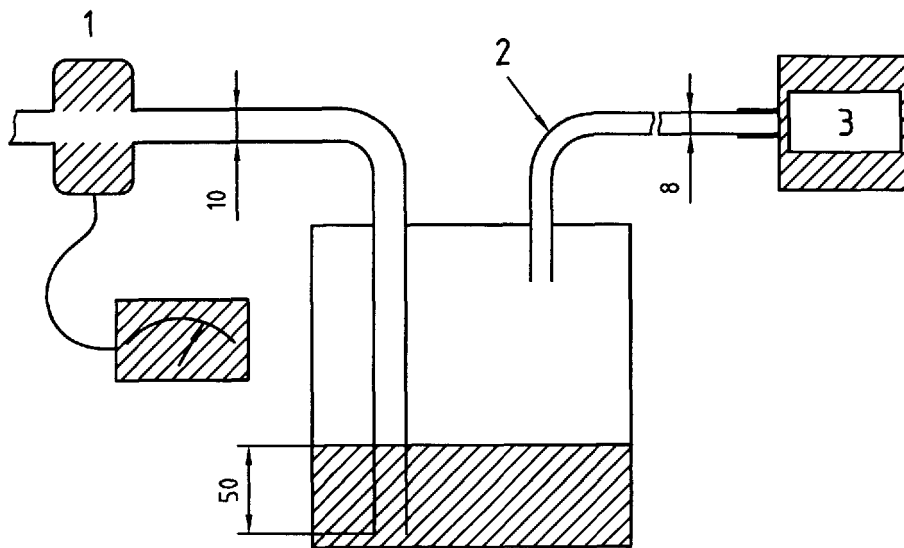

Key

- 1 Low-resistance flowmeter (< 0,1 kPa at 25 l/min)
- 2 Tubing of length 2 m
- 3 Equipment under test

Figure 6 — Test apparatus for thoracic drainage

59.9 Equipment intended for pharyngeal suction

Equipment intended for pharyngeal suction shall evacuate 200 ml of simulated vomitus in not more than 10 s.

Compliance shall be checked by the following test.

Prepare simulated vomitus by dissolving 10 g of food grade xanthan gum in 1 l of distilled water and adding 100 g of 1 mm diameter glass beads having a specific gravity of 2,55. Agitate the simulated vomitus to disperse the glass beads and pour 250 ml at an ambient temperature of $(22 \pm 3) ^\circ\text{C}$ into a graduated cylinder having a capacity of at least 300 ml with graduations no more than 50 ml apart. Attach the suction tubing to the suction equipment and operate the equipment with the level of the simulated vomitus at the same horizontal level as the top of the collection container. Place the suction tubing in the graduated cylinder and record the time taken to evaluate 200 ml of the simulated vomitus.

NOTE In the preparation of the simulated vomitus, 0,1 % benzoic acid may be added as a preservative.

59.10 Battery-powered transportable suction equipment

Battery-powered suction equipment intended for field and/or transport use shall operate for at least 20 min, during which time it shall produce a free air flow of not less than 20 l/min and a vacuum of not less than 40 kPa below atmospheric pressure.

Compliance shall be checked by the following test.

Ensure that the power supply of the equipment is fully charged according to the manufacturer's instructions. Attach a low-resistance flowmeter with a pressure drop of less than 1 kPa at 30 l/min free air flow to the inlet of the collection container. Insert an adjustable flow restrictor and an open tube in parallel with a switch after the flowmeter, as shown in Figure 7. Attach an ammeter in series with the battery.

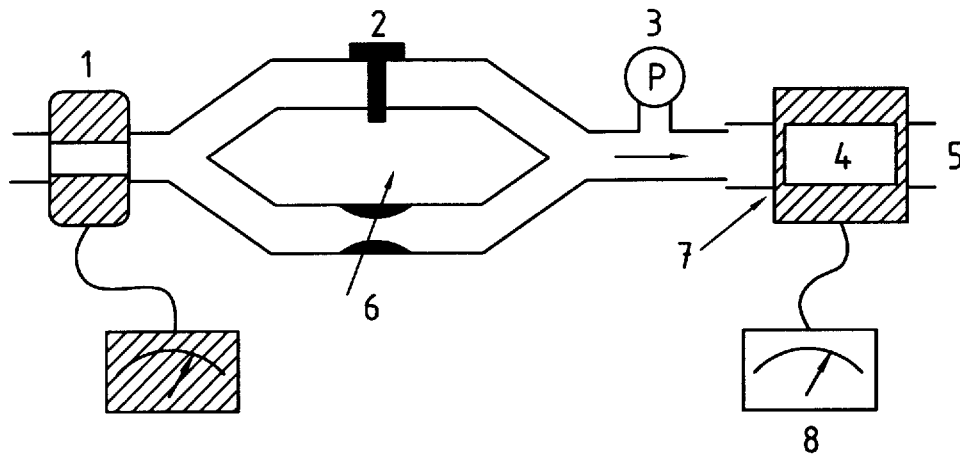

Key

- 1 Flowrate measuring device
- 2 Switch
- 3 Vacuum indicator
- 4 Equipment under test
- 5 Exhaust
- 6 Adjustable resistor
- 7 Suction endpiece
- 8 Ammeter

Figure 7 — Test apparatus for battery-powered transportable suction equipment

Operate the equipment with the patient connection occluded and record the maximum vacuum after 15 s. Adjust the restrictor to operate the equipment at maximum current. Run the equipment continuously, alternating between 15 s maximum load and 15 s free air flow.

Record the maximum vacuum and the first time at which either the free air flow drops below 20 l/min or the set patient flow (maximum current load) declines to 80 % of the initial flow value used for maximum load, or, if the test is conducted with no flow, the time at which the vacuum drops below 40 kPa below atmospheric pressure.

59.11 Collection container

59.11.1 General

For all suction equipment, one or more collection containers clearly visible in the position of normal use shall be provided.

Compliance shall be checked by inspection.

The collection container shall be marked with its usable volume, in millilitres. For collection containers of 500 ml or greater, approximate indication of the volume shall be given by graduations. The interval of the graduation should be not less than 50 ml and not more than 250 ml.

The collection container shall have a minimum volume of 200 ml and shall be sufficiently transparent so that the level of contents can be observed. If the suction equipment ceases to operate when the collection container is full, the collection container shall have a minimum usable volume of 500 ml.

NOTE An indication of appropriate range of volumes for the collection container for some common procedures is given in annex N.

59.11.2 Resistance to implosion

Unless otherwise stated on the collection container or in the accompanying documents, collection containers for all suction equipment except that marked for wound drainage or thoracic drainage shall maintain their integrity and shall not permanently deform nor implode at an applied vacuum of 95 kPa below atmospheric pressure.

Compliance shall be checked by the following test.

Place the collection container in a protective enclosure, for example a box or bag, at 20 °C to 25 °C. Attach a vacuum source to the collection container opening as shown in Figure 8. Evacuate the collection container to 120 % of the manufacturer's recommended maximum vacuum or to a vacuum not exceeding 95 kPa below atmospheric pressure, whichever is greater. If there is no stated maximum vacuum, apply a vacuum of 95 kPa below atmospheric pressure. Hold the vacuum for 5 min, and then release. Repeat the procedure once. Visually inspect the collection container for deformation and/or implosion.

For resterilizable collection containers, carry out the test after the container has been subjected to 30 cycles of sterilization as recommended by the manufacturer.

WARNING - This test can be hazardous. Care should be taken to protect personnel from possible flying debris.

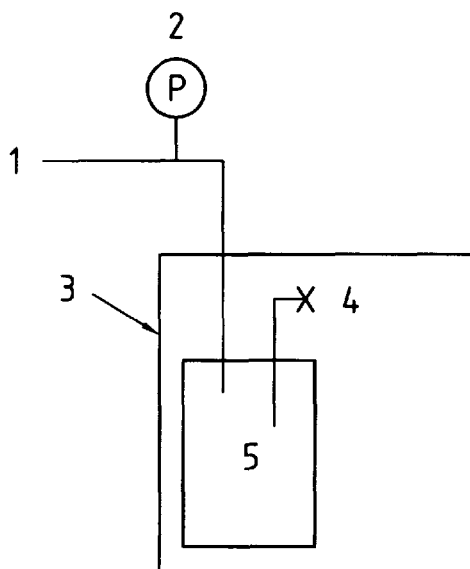

Key

- 1 Vacuum source
- 2 Vacuum indicator
- 3 Protective enclosure (loose fitting, not sealed)
- 4 Closed to atmosphere
- 5 Test collection container

Figure 8 — Apparatus for testing resistance to deformation or implosion of collection container

59.12 Filter

The air leaving the collection container should pass through a filter or other means of protecting the pump from inadvertent contamination before entering the vacuum pump. For reciprocating pumps, e.g. piston or diaphragm, depending on valves to control flow, a filter also protects against pump malfunction.

59.13 Wheels and castors

Wheels or castors, if fitted, shall have a diameter of not less than 50 mm.

Annexes A to L

Annexes A to L given in IEC 60601-1:1988 apply.

Annex M

(informative)

Rationale statement

This annex provides a concise rationale for the important requirements of this part of ISO 10079 and is intended for those who are familiar with the subject of this part of ISO 10079 but who have not participated in its development. Understanding of the reasons for the main requirements is considered to be essential for the proper application of this part of ISO 10079. Furthermore, as clinical practice and technology change, it is believed that a rationale for the present requirements will facilitate any revision of this part of ISO 10079 necessitated by those developments.

Remarks made in this annex apply to the relevant clause or subclause in this part of ISO 10079; the numbering is, therefore, not consecutive.

1 Scope

Suction may be created by a vacuum pump supplying a pipeline, by a mobile electrically driven vacuum pump, or, in the case of ISO 10079-2, by manual means or by other sources of power such as water, steam or other gases. The most common sources are pipeline supply and electrically and manually driven vacuum pumps.

The safety procedures, recommended suction strengths, etc. should apply to medical suction generated by any means. The basic high and low suction parameters should allow people to "benchmark" these standards against performance of the less-used systems.

The vacuum and suction may be generated by an installed system or by a portable system.

12 Protection against hazards of ignition of flammable anaesthetic mixtures (clauses 37-41 of IEC 60601-1:1988)

Numerous items found in anaesthetizing locations are capable of producing a spark. Since at present flammable anaesthetics are rarely used, it shall now be assumed that apparatus is NOT safe with flammable anaesthetics unless specifically labelled.

Annex N (informative)

Table of typical ranges of volume for collection containers for specific uses

NOTE Where more specific or multiple uses are intended, the most appropriate volume may differ from the range suggested. Local experience may also justify deviations from the suggested range of volume.

Table N.1

Use	Range of volume litres
Surgical suction	1,5 to 4
Adult or infant oral /nasal /tracheal suction	0,7 to 1,5
Gastric drainage	1 to 2
Wound drainage	0,5 to 1
Adult pleural or mediastinal drainage	1 to 2
Paediatric pleural or mediastinal drainage	0,25 to 1
Field and transport use	0,2 to 1,5 ^a
^a Applies to suction equipment with pump-through capability.	

Annex O (informative)

Lumen (passageway) size and its effects on flow

The laminar flow of fluid (gas or liquid) is approximately proportional to the fourth power of the inside diameter (ID) of the lumen, and inversely proportional to the length.

For each system setup, it is suggested that the largest diameter and shortest tube practical be used.

Table O.1 shows the relative flowrates of various sizes of straight tubing under similar conditions. The flow through a 6,35 mm ID tube is designated as 100 %.

Table O.1 — Relative flowrates of straight tubing

Diameter mm	Flow %	Estimated pressure drop over 2 m length ^a kPa	Approximate water flowrate through 2 m length ^b l/min
4,76	30	6,26	2,7
(5)	40	5,20	3,2
5,56	60	3,33	4,0
(6)	80	2,53	4,7
6,35 ^c	100	2,00	5,5
(7)	150	1,33	6,2
7,14	160	1,07	6,5
7,93	240	0,67	7,7
(8)	250	0,64	7,8

^a Estimated vacuum loss per 2 m length of straight tubing flowing 20 l/min air at a vacuum source of 40 kPa below atmospheric pressure. Specific brands of tubing may give slightly different results depending on smoothness of lumen and properties of material.

^b These flowrates are for horizontally positioned tubing at ambient temperature and an applied vacuum of 40 kPa below atmospheric pressure.

^c Suggested minimum diameter.

ICS 17.040.10

Price based on 28 pages
