**Tools for pressing — Elastomer pressure
springs —**

Part 2:
Specification of accessories

*Outillage de presse — Ressorts de compression en élastomère —
Partie 2: Spécifications des accessoires*



PDF disclaimer

This PDF file may contain embedded typefaces. In accordance with Adobe's licensing policy, this file may be printed or viewed but shall not be edited unless the typefaces which are embedded are licensed to and installed on the computer performing the editing. In downloading this file, parties accept therein the responsibility of not infringing Adobe's licensing policy. The ISO Central Secretariat accepts no liability in this area.

Adobe is a trademark of Adobe Systems Incorporated.

Details of the software products used to create this PDF file can be found in the General Info relative to the file; the PDF-creation parameters were optimized for printing. Every care has been taken to ensure that the file is suitable for use by ISO member bodies. In the unlikely event that a problem relating to it is found, please inform the Central Secretariat at the address given below.



COPYRIGHT PROTECTED DOCUMENT

© ISO 2008

All rights reserved. Unless otherwise specified, no part of this publication may be reproduced or utilized in any form or by any means, electronic or mechanical, including photocopying and microfilm, without permission in writing from either ISO at the address below or ISO's member body in the country of the requester.

ISO copyright office
Case postale 56 • CH-1211 Geneva 20
Tel. + 41 22 749 01 11
Fax + 41 22 749 09 47
E-mail copyright@iso.org
Web www.iso.org

Published in Switzerland

Foreword

ISO (the International Organization for Standardization) is a worldwide federation of national standards bodies (ISO member bodies). The work of preparing International Standards is normally carried out through ISO technical committees. Each member body interested in a subject for which a technical committee has been established has the right to be represented on that committee. International organizations, governmental and non-governmental, in liaison with ISO, also take part in the work. ISO collaborates closely with the International Electrotechnical Commission (IEC) on all matters of electrotechnical standardization.

International Standards are drafted in accordance with the rules given in the ISO/IEC Directives, Part 2.

The main task of technical committees is to prepare International Standards. Draft International Standards adopted by the technical committees are circulated to the member bodies for voting. Publication as an International Standard requires approval by at least 75 % of the member bodies casting a vote.

Attention is drawn to the possibility that some of the elements of this document may be the subject of patent rights. ISO shall not be held responsible for identifying any or all such patent rights.

ISO 10069-2 was prepared by Technical Committee ISO/TC 29, *Small tools*, Subcommittee SC 8, *Tools for pressing and moulding*.

This second edition cancels and replaces the first edition (ISO 10069-2:1991), of which it constitutes a minor revision. In particular, the indication of surface textures has been updated in accordance with ISO 1302:2002.

ISO 10069 consists of the following parts, under the general title *Tools for pressing — Elastomer pressure springs*:

- *Part 1: General specification*
- *Part 2: Specification of accessories*

Tools for pressing — Elastomer pressure springs —

Part 2: Specification of accessories

1 Scope

This part of ISO 10069 specifies the dimensions, in millimetres, of spring collars and pilot pins intended for use in press tools together with elastomer pressure springs in accordance with ISO 10069-1.

This part of ISO 10069 also gives information concerning materials and their hardness, and specifies the designation of spring collars and pilot pins that are in accordance with its requirements.

2 Normative references

The following referenced documents are indispensable for the application of this document. For dated references, only the edition cited applies. For undated references, the latest edition of the referenced document (including any amendments) applies.

ISO 10069-1, *Tools for pressing — Elastomer pressure springs — Part 1: General specification*

3 Dimension

3.1 Spring collars

The dimensions of spring collars shall be in accordance with Figure 1 and Table 1.

Surface roughness values in micrometres

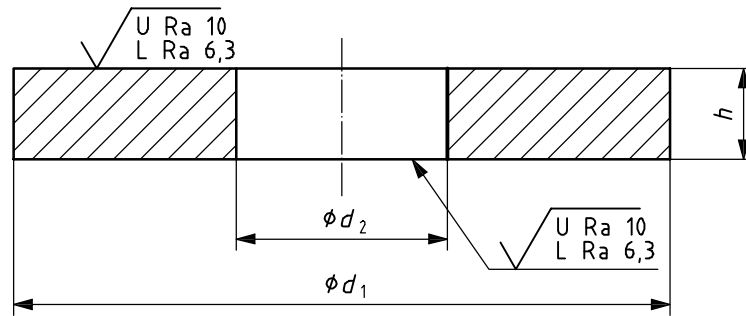

Figure 1 — Spring collar

Table 1 — Dimensions of spring collars

Dimensions in millimetres

d_1	20	25	30	40	50	60	80	100	120	150
d_2	6,5	8,5	10,5	13,5	13,5	16,5	16,5	20,5	20,5	26
h	4	4	5	5	5	6	6	8	8	8

3.2 Pilot pins

The dimensions of pilot pins shall be in accordance with Figure 2 and Table 2.

Surface roughness values in micrometres

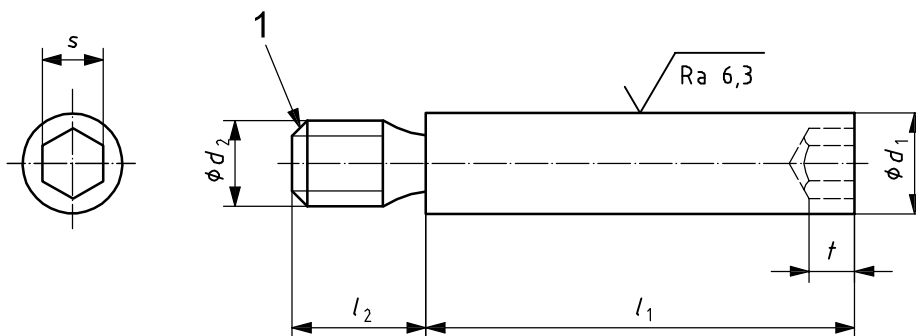

Key

- 1 chamfered end

Figure 2 — Pilot pin

Table 2 — Dimensions of a pilot pin

Dimensions in millimetres

d_1 h11	l_1	d_2	l_2	s	t
6	20	M4	6	3	2,5
	25				
	32				
	40				
8	25	M6	9	4	3
	32				
	40				
	50				
10	32	M8	15	5	4
	40				
	50				
	63				
13	40	M10	15	6	5
	50				
	63				
	80				
	95				
16	63	M12	18	8	6
	80				
	95				
	118				
	140				
20	95	M16	25	10	8
	118				
	140				
	180				
	224				
25	140	M20	30	14	10
	180				
	224				
	265				
	340				

4 Materials and their hardness

The choice of material and its hardness are left to the manufacturer's discretion.

5 Designation

5.1 Spring collar

A spring collar in accordance with this part of ISO 10069, for use with elastomer pressure springs, shall be designated by a designation comprising the following elements:

- a) "Spring collar";
- b) reference to this part of ISO 10069 (i.e. ISO 10069-2);
- c) its diameter, d_1 .

EXAMPLE A spring collar with a diameter, d_1 , of 20 mm is designated as follows:

Spring collar ISO 10069-2 - 20

5.2 Pilot pin

A pilot pin in accordance with this part of ISO 10069 shall be designated as follows:

- a) "Pilot pin";
- b) reference to this part of ISO 10069 (i.e. ISO 10069-2);
- c) its diameter, d_1 ;
- d) its length, l_1 .

EXAMPLE A pilot pin with a diameter, d_1 , of 6 mm and length, l_1 , of 20 mm is designated as follows:

Pilot pin ISO 10069-2 - 6 × 20

Bibliography

- [1] ISO 1302:2002, *Geometrical Product Specifications (GPS) — Indication of surface texture in technical product documentation*

