

INTERNATIONAL  
STANDARD

ISO  
10059-1

First edition  
1992-02-01

ANSI Internat Doc Sec

---

---

**Dense, shaped refractory products —  
Determination of cold compressive strength —**

**Part 1:  
Referee test without packing**

*Produits réfractaires façonnés denses — Détermination de la résistance  
à la compression à température ambiante —*

*Partie 1: Méthode d'essai de référence sans intercalaire*



Reference number  
ISO 10059-1:1992(E)

## Foreword

ISO (the International Organization for Standardization) is a worldwide federation of national standards bodies (ISO member bodies). The work of preparing International Standards is normally carried out through ISO technical committees. Each member body interested in a subject for which a technical committee has been established has the right to be represented on that committee. International organizations, governmental and non-governmental, in liaison with ISO, also take part in the work. ISO collaborates closely with the International Electrotechnical Commission (IEC) on all matters of electrotechnical standardization.

Draft International Standards adopted by the technical committees are circulated to the member bodies for voting. Publication as an International Standard requires approval by at least 75 % of the member bodies casting a vote.

International Standard ISO 10059-1 was prepared by Technical Committee ISO/TC 33, *Refractories*, Sub-Committee SC 2, *Methods of testing*.

ISO 10059 consists of the following parts, under the general title *Dense, shaped refractory products — Determination of cold compressive strength*:

- *Part 1: Referee test without packing*
- *Part 2: Test with packing*

© ISO 1992

All rights reserved. No part of this publication may be reproduced or utilized in any form or by any means, electronic or mechanical, including photocopying and microfilm, without permission in writing from the publisher.

International Organization for Standardization  
Case Postale 56 • CH-1211 Genève 20 • Switzerland

Printed in Switzerland

## **Introduction**

ISO 10059 will be published in two Parts. Part 1 specifies a referee method for the determination of cold compressive strength, which does not use any packing material. Part 2 will specify an alternative test where packing material and alternative test piece sizes are permitted.

The test for shaped insulating products is given in ISO 8895.

# Dense, shaped refractory products — Determination of cold compressive strength —

## Part 1:

### Referee test without packing

#### 1 Scope

This International Standard specifies a method of determination of the cold compressive strength of dense, shaped refractory products.

#### 2 Normative references

The following standards contain provisions which, through reference in this text, constitute provisions of this part of ISO 10059. At the time of publication, the editions indicated were valid. All standards are subject to revision, and parties to agreements based on this part of ISO 10059 are encouraged to investigate the possibility of applying the most recent editions of the standards indicated below. Members of IEC and ISO maintain registers of currently valid International Standards.

ISO 5017:1988, *Dense shaped refractory products — Determination of bulk density, apparent porosity and true porosity*.

ISO 8895:1986, *Shaped insulating refractory products — Determination of cold crushing strength*.

#### 3 Definitions

For the purposes of this part of ISO 10059, the following definitions apply.

**3.1 cold compressive strength:** The maximum load per unit area, applied under specified conditions at room temperature, that a refractory product will withstand before failure occurs.

**3.2 dense, shaped product:** A product having a true porosity of less than 45 %, when measured in accordance with ISO 5017.

#### 4 Principle

A test piece of known dimensions is subjected, under specified conditions, to a steadily increasing compressive load until it fails, i.e. when it cannot support a further increase in load. The cold compressive strength is calculated from the maximum load indicated at failure and the mean cross-sectional area over which the load is applied.

#### 5 Apparatus

**5.1 A mechanical or hydraulic compression testing machine**, fitted with a measuring device capable of measuring the load exerted on the test piece to within  $\pm 2$  %.

The machine shall be capable of increasing the stress at a rate of  $1,0 \text{ N/mm}^2 \cdot \text{s} \pm 0,1 \text{ N/mm}^2 \cdot \text{s}$ , until the test piece is unable to support the load.

The platens of the machine shall

- a) have a Rockwell hardness value between 58 HRC and 62 HRC;
- b) be ground plane to a flatness tolerance of 0,03 mm over the area to be in contact with the test piece;
- c) have a surface texture (mean roughness value  $R_a$ ) between  $0,8 \mu\text{m}$  and  $3,2 \mu\text{m}$ . This can be checked visually or by feeling with a "mean-roughness" reference standard such as is used for flat grinding.

The area of the upper platen shall not be greater than  $100 \text{ cm}^2$ . The upper platen shall function on a

seating that will compensate for small deviations from parallelism between the platen and test piece.

A testing machine whose upper platen does not comply with the above requirements for size can be used in conjunction with an ancillary adaptor (see figure 1) placed centrally between the platens of the machine. The platens of the adaptor shall comply with the machine platen requirements for hardness and flatness given in this subclause. They shall have a thickness of at least 10 mm.

NOTE 1 The platens should be replaceable to allow re-machining and should not be matted.

**5.2 Vernier calipers**, for measurement of test pieces (see 6.3, 6.4 and 7).

**5.3 Set square**.

**5.4 Drying oven**, capable of being controlled at  $110\text{ }^{\circ}\text{C} \pm 5\text{ }^{\circ}\text{C}$ .

## 6 Test pieces

**6.1** Test pieces shall be cylinders  $50\text{ mm} \pm 0,5\text{ mm}$  in diameter and  $50\text{ mm} \pm 0,5\text{ mm}$  in height. Where it is not possible to obtain this size from the item, cylinders  $36\text{ mm} \pm 0,3\text{ mm}$  in diameter and  $36\text{ mm} \pm 0,3\text{ mm}$  in height shall be used.

**6.2** Test pieces shall be prepared by drilling cylinders from the item(s), in the same direction as the forming pressure during the manufacture of the item, where this is known. The original position of the test pieces in the item(s) shall be noted. Test pieces containing cracks or visible defects shall be discarded and this shall also be noted.

Both ends of the cylindrical test piece shall be made plane and parallel, grinding the surfaces where required. To ensure that the top and bottom ends of the test pieces are plane over their entire surface, each end shall in turn be pressed, with a load of  $3\text{ kN} \pm 1\text{ kN}$ , onto a levelling plate which is lined with carbon or blue paper and hard filter paper (0,15 mm in thickness). Test pieces that do not show two complete, clearly visible coloured impressions shall be reground. See figures 2 to 5 for examples.

NOTE 2 A steel straight-edge may be used to assist in checking the surfaces. Mortar may not be used to plane the surfaces.

**6.3** The parallelism of the test pieces shall be checked by four measurements of the height, at the extremities of two perpendicular diameters. The difference between any two of these measurements shall not exceed 0,2 mm.

**6.4** The perpendicularity shall be checked by placing the test piece on a plane surface and using a set square, placed against the side of the test piece, at four positions corresponding to the height measurements. The gap between the side of the test piece and the set square shall not exceed 0,5 mm.

**6.5** The prepared test pieces shall be carefully dried to constant mass by placing them in a drying oven at  $110\text{ }^{\circ}\text{C} \pm 5\text{ }^{\circ}\text{C}$ . They are then cooled to room temperature and kept away from moisture until the start of the test.

## 7 Procedure

Measure two perpendicular diameters of each surface to within 0,1 mm. From the arithmetic mean of these four measurements, calculate the initial cross-sectional area  $A_0$ .

Place the test piece or the ancillary adaptor with the test piece in it centrally between the platens of the machine, without using any packing between the test piece and the platens.

Select the load range so that the expected load at failure is greater than 10 % of the load range.

Apply the load smoothly and continuously, increasing the stress at the rate of  $1,0\text{ N/mm}^2\cdot\text{s} \pm 0,1\text{ N/mm}^2\cdot\text{s}$  until the test piece fails, i.e. until it is unable to support the load. Record the maximum load indicated.

NOTE 3 A graph of applied load against time is recommended for showing the results.

## 8 Expression of results

The cold compressive strength of the test piece,  $\sigma$ , expressed in newtons per square millimetre, is given by the expression:

$$\sigma = \frac{F_{\max}}{A_0}$$

where

$F_{\max}$  is the maximum load recorded, expressed in newtons;

$A_0$  is the mean initial cross-sectional area, in square millimetres, of the test piece over which the load is applied.

The result shall be given to three significant figures.

NOTE 4 Repeatability and reproducibility data are in the course of preparation.

## 9 Test report

The test report shall include the following information:

- a) the name of the testing establishment;
  - b) the date of the test;
  - c) a reference to this International Standard, i.e. "Determination of cold compressive strength in accordance with ISO 10059-1";
  - d) the designation of the material tested (manufacturer, size, quality, etc.);
  - e) the number of items tested;
  - f) the number of test pieces cut from each item;
  - g) the size of the test pieces (see 6.1);
  - h) the location of the test piece(s) in the item and the relationship to the direction of pressing (see 6.2);
- i) the location of any defective test pieces (see 6.2);
  - j) the individual value of strength for each test piece;
  - k) the mean value of strength for each item, where different from that given in j);
  - l) the mean value of strength for the batch sampled.

**NOTE 5** The scattering of the cold compressive strength values consists of the scattering between the items (bricks) of one lot and between the test pieces taken from these items. These scatterings depend on the material and the manufacturing procedure of the items tested and on the repeatability and reproducibility of the test method.

If values for repeatability and reproducibility are stated, it should be noted whether they are valid for the individual values of all the test pieces or for the mean values calculated from the individual values of one item.

Dimensions in millimetres

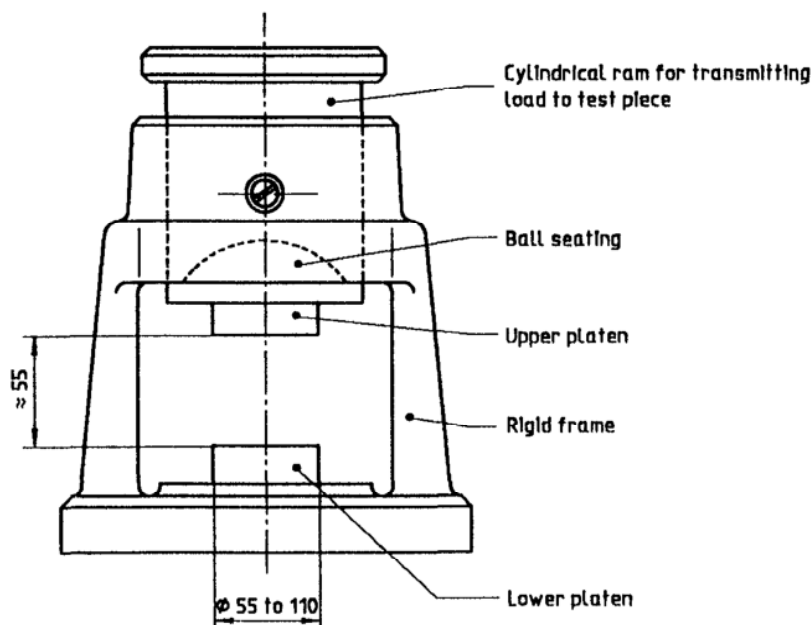
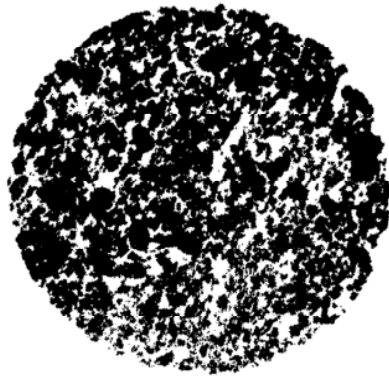

Figure 1 — Ancillary adaptor



a) Coarse grained brick type



b) Fine grained brick type

Figure 2 — Carbon or blue paper replica: good



a) Coarse grained brick type

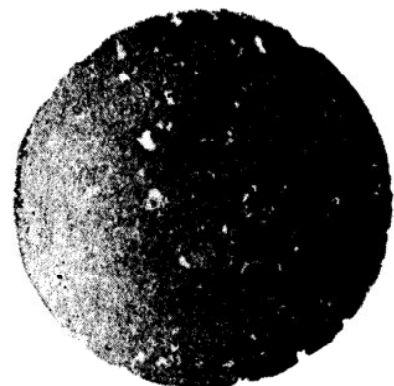

b) Fine grained brick type

Figure 3 — Carbon or blue paper replica: still admissible

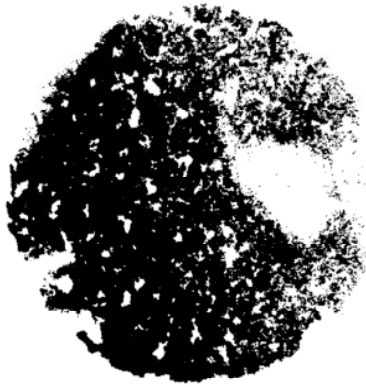

a) Coarse grained brick type



b) Fine grained brick type

**Figure 4 — Carbon or blue paper replica: not admissible**



**Figure 5 — Carbon or blue paper replica: not admissible because grooves are visible after sawing or grinding**



---

---

**UDC 666.76-128:620.173.2**

**Descriptors:** refractory materials, shaped refractories, tests, mechanical tests, determination, compressive strength.

Price based on 5 pages

---

---