

INTERNATIONAL
STANDARD

ISO
10046

First edition
1996-12-15

ANSI Internat Doc Sec

**Aircraft — Methodology of calculating
cargo compartment volumes**

Aéronefs — Méthode de calcul du volume des soutes à fret



Reference number
ISO 10046 1996(E)

Foreword

ISO (the International Organization for Standardization) is a worldwide federation of national standards bodies (ISO member bodies). The work of preparing International Standards is normally carried out through ISO technical committees. Each member body interested in a subject for which a technical committee has been established has the right to be represented on that committee. International organizations, governmental and non-governmental, in liaison with ISO, also take part in the work. ISO collaborates closely with the International Electrotechnical Commission (IEC) on all matters of electrotechnical standardization.

Draft International Standards adopted by the technical committees are circulated to the member bodies for voting. Publication as an International Standard requires approval by at least 75 % of the member bodies casting a vote

International Standard ISO 10046 was prepared by Technical Committee ISO/TC 20, *Aircraft and space vehicles*, Subcommittee SC 9, *Air cargo and ground equipment*.

© ISO 1996

All rights reserved. Unless otherwise specified, no part of this publication may be reproduced or utilized in any form or by any means, electronic or mechanical, including photocopying and microfilm, without permission in writing from the publisher

International Organization for Standardization
Case Postale 56 • CH-1211 Genève 20 • Switzerland

Printed in Switzerland

Introduction

The purpose of this International Standard is to establish a uniform methodology for defining and determining the usable internal volume of aircraft cargo compartments, and usable external envelope for Unit Load Devices (ULDs) which can be accommodated within these compartments. This will provide the aircraft industry with a set of standard methodology which when specified, can be utilized by the airlines when comparing similar type aircraft.

Aircraft — Methodology of calculating cargo compartment volumes

1 Scope

This International Standard covers the methodology of defining and determining the internal volumes of both the main deck and lower deck aircraft cargo compartments. The minimum required clearance between the compartment envelope and the unit load devices (ULDs) is also stated in order to provide the maximum ULD external contour and the methodology to define the ULD internal volumes.

2 Normative reference

The following standard contains provisions which, through reference in this text, constitute provisions of this International Standard. At the time of publication, the edition indicated was valid. All standards are subject to revision, and parties to agreements based on this International Standard are encouraged to investigate the possibility of applying the most recent edition of the standard indicated below. Members of IEC and ISO maintain registers of currently valid International Standards.

ISO 10254:1995, *Air cargo and ground equipment — Vocabulary*

3 Definitions

For the purposes of this International Standard, the definitions given in ISO 10254 apply.

4 Compartment internal volumes

4.1 Main deck compartment

The main deck compartment internal volume may be calculated and listed as maximum usable volume, provided that bulk cargo is compartment restrained, i.e. the floor, ceiling, sidewalls, bulkheads, nets and supporting structure are capable of withstanding the bulk cargo restraint loads associated with all flight and ground load conditions with applicable load factors, including 9g forward emergency landing condition. If bulk cargo is not compartment restrained, then the internal volume value shall be followed by an asterisk (*) denoting that the usable volume shall be derived from cumulative ULD volumes as specified in clause 5. The following criteria shall apply to define the main deck compartment envelope limits.

4.1.1 The usable compartment length shall be that length of the main deck floor which is designed to support bulk cargo stacked over the entire floor area. If a forward barrier net is required, then only that portion of the usable floor length aft of the barrier net station shall be utilized. See figure 1.

4.1.2 The usable compartment height shall be the minimum height between floor or the top of the conveyor rollers and ceiling structure or lining under which cargo must pass during loading/unloading procedures. See figure 2. This will take into account mid-cabin drop ceilings. Local protrusions at either end of the compartment under which cargo may be stowed but not passed beyond shall be accounted for in calculating the internal volume, but shall not govern the compartment height. In no case shall the compartment height exceed the main deck loading doorway height. See figure 2.

4.1.3 The usable compartment width shall be the actual cross-sectional width of the compartment, provided that the sidewall liner is capable of withstanding the bulk cargo restraint loads. If the sidewall liner is not capable of withstanding this load, then only the width inboard of a lateral restraint device shall be utilized. See figure 3.

4.2 Lower deck compartments

The lower deck compartment internal volumes shall be calculated and listed as maximum usable volumes, provided that bulk cargo is compartment restrained, i.e. the floor, ceiling, sidewalls, bulkheads, nets and supporting structure are capable of withstanding the bulk cargo restraint loads associated with all flight and ground load conditions with applicable load factors. If bulk cargo is not compartment restrained, the internal volume value shall be followed by an asterisk (*) denoting that the usable volume shall be derived from cumulative ULD volumes as specified in clause 5. The following criteria shall apply to define the lower deck compartment envelope limits.

4.2.1 The usable compartment length shall be that length of the lower deck floor which is designed to support bulk cargo stacked over the entire floor area. This requires that the end bulkheads are designed to withstand bulk cargo restraint loads. See figure 4.

4.2.2 The usable compartment height shall be the actual height between floor and ceiling surfaces, provided that both are capable of withstanding bulk cargo restraint loads. The height that a cargo loading system protrudes above the floor surface need not be discounted, provided that the system is easily removed or inverted when bulk cargo is being transported. The cargo doorway height, if less than the internal compartment height, shall be considered when establishing the usable height to define the maximum ULD envelope, but it need not be the controlling factor to establish the usable compartment height to define the internal bulk cargo compartment volume. See figure 5.

4.2.3 The usable compartment width shall be the actual cross-sectional width, provided that the sidewall liners (vertical and sloping) are capable of withstanding bulk cargo restraint loads. See figure 6.

Where the sides, or floor and ceiling, of the compartment are not parallel, a number of cross-section dimensions may be required, all of which will have to take into account vertical and sloping sidewalls. In this case, calculating the volume will require that an accurate cross-section is applied to the linear dimension of the compartment.

4.2.4 The volume lost due to installation of doorway barriers shall be accounted for in determining the internal volume, by assuming planes between floor, ceiling and sidewall which encompass all of the barrier tiedown/attach points.

5 Unit load device envelopes

IATA 50/Series Specifications from the IATA Unit Load Devices (ULD) Technical Manual define the available contours and configurations for unit load devices (ULDs) which can be accommodated within the cargo compartment to assist in transporting cargo.

The allowable clearance between aircraft interior and various types of ULDs are shown in figure 7 and shall be based upon the minimum cross section of the aircraft through which or in which the ULD will traverse or be stowed.

5.1 Container envelope and volume

Containers are rigid unit load devices, including both structural and non-structural igloo assemblies, with controlled contour shapes. The structural container and nonstructural container/igloo shall allow 51 mm (2 in) of clearance to the minimum aircraft envelope in accordance with figure 7.

The internal volume of containers shall be listed as usable volumes and shall be calculated by taking 93,5 % of the external envelope volume. This will account for the floor, ceiling, sidewalls, internal stiffeners, longerons and supports. The value of 93,5 % is not applicable to forkliftable containers.

5.2 Pallet load envelope and volume

A cargo pallet is a flat ULD, having no side or end walls, on which cargo is stacked, and utilizes overthrow nets to secure the stacked cargo load. The palletized cargo contour shall allow 51 mm (2 in) of clearance to the minimum aircraft envelope, except in areas where it is necessary to allow a greater clearance to protect critical aircraft components, in order to account for irregular shaped loads and load shifting which can occur. The 51 mm (2 in) of clearance does not apply to the net/hardware, but in no case shall the net/hardware be within 51 mm (2 in) of the aircraft envelope. The palletized cargo shall also have a 51 mm (2 in) setback from the outer edge of the pallet on all sides to permit attachment of net hardware to the pallet. See figure 8. A 100 mm (4 in) longitudinal clearance shall be provided for cargo in line with any aircraft structure, unless that structure is designed to withstand bulk cargo restraint loads. See figure 7.

The volume of a palletized ULD shall be calculated and listed as usable volume, utilizing the following guidelines. Pallet thickness shall be assumed as 20 mm (0,75 in) for commercial pallets and 57 mm (2,25 in) for military pallets, unless otherwise specified. The palletized cargo shall have a 51 mm (2 in) setback from the outer edges of the pallet. The height shall be controlled by the 51 mm (2 in) clearance dimension to the minimum aircraft envelope through which the palletized ULD must pass during the loading/unloading cycle. See figure 7. A 15 cm (6 in) longitudinal clearance shall be provided for any change in contour shape due to overhead or sidewall protrusions in line with the ULD stowed position. See figure 8.

© 1996 International Organization for Standardization

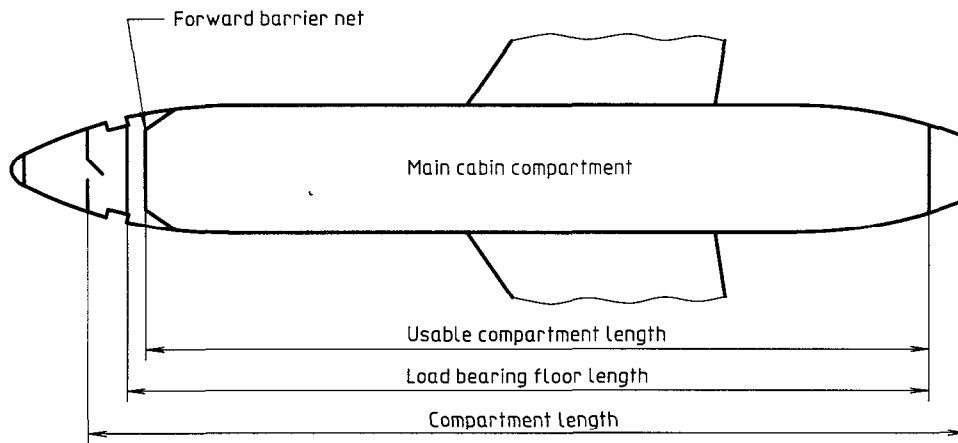

Figure 1 — Main check compartment usable length

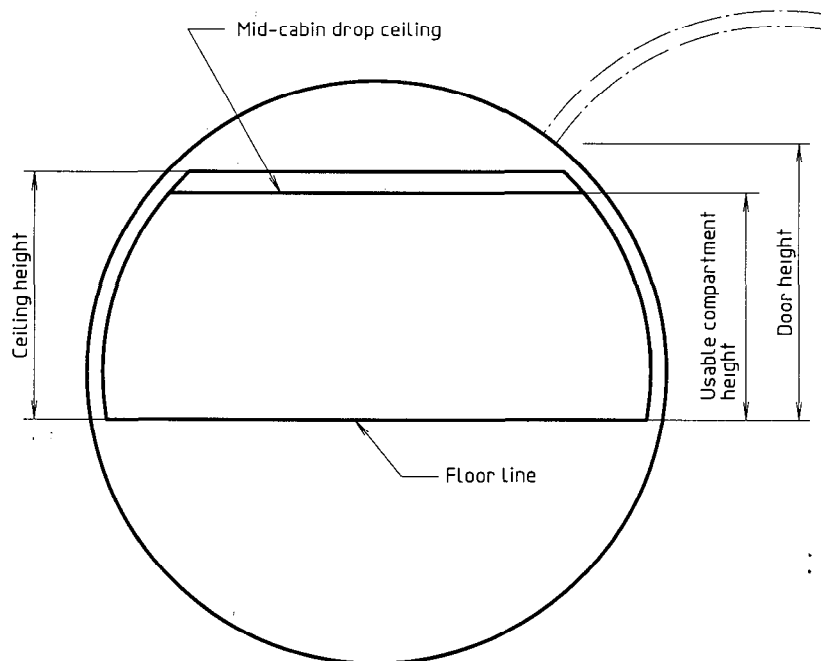

Figure 2 — Main desk compartment usable height

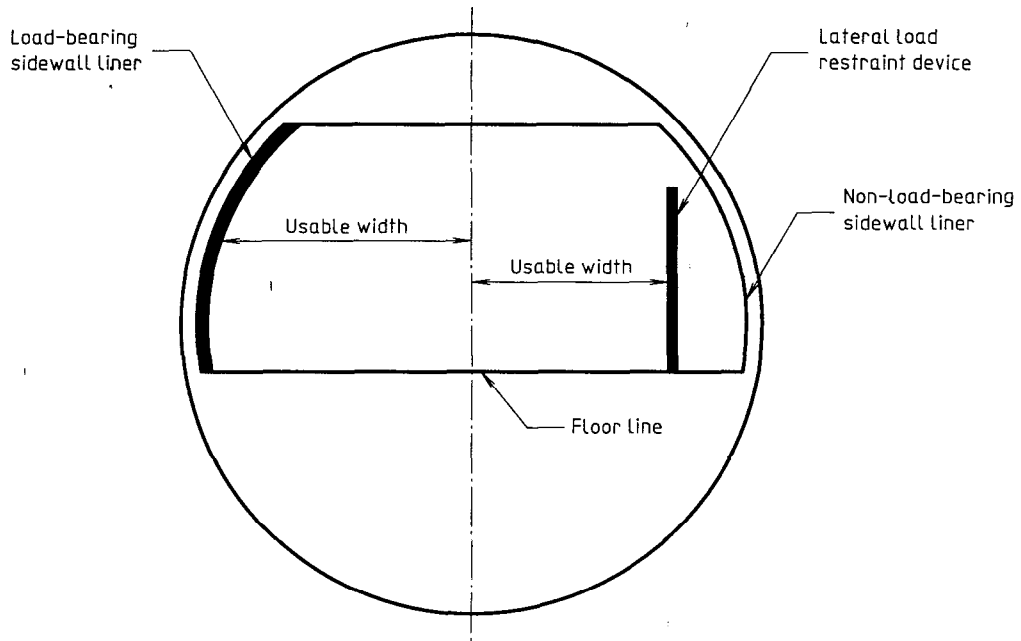

Figure 3 — Main deck compartment usable width

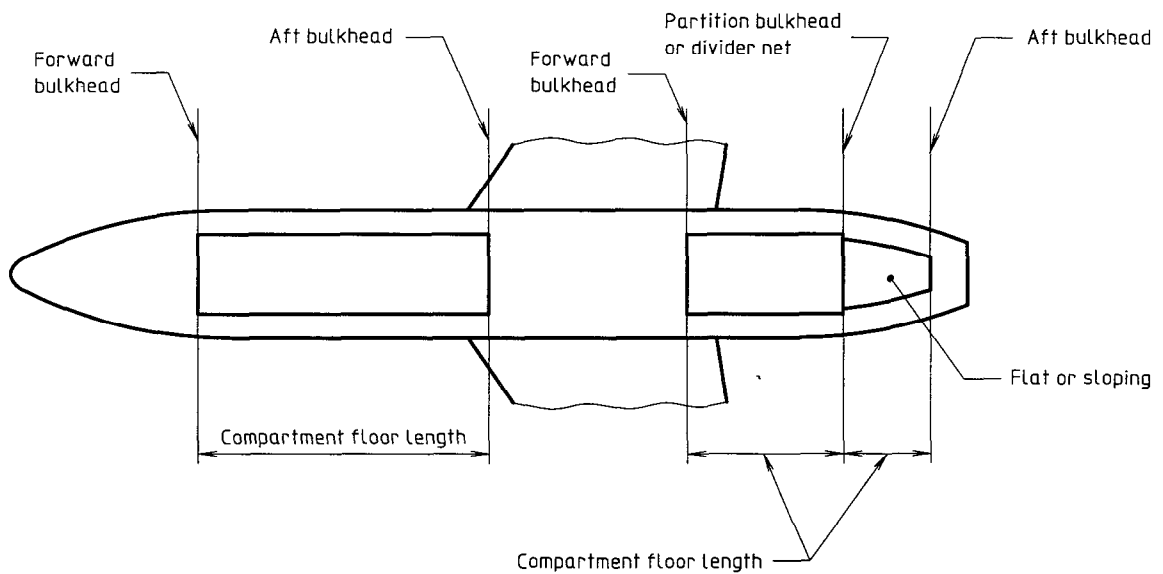

Figure 4 — Lower deck compartment usable length

© ISO 1996

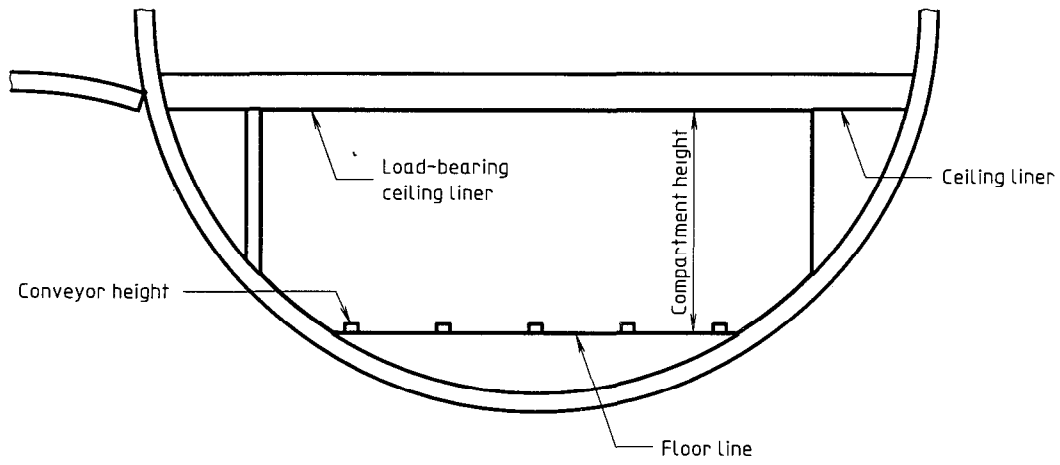

Figure 5 — Lower deck compartment usable height

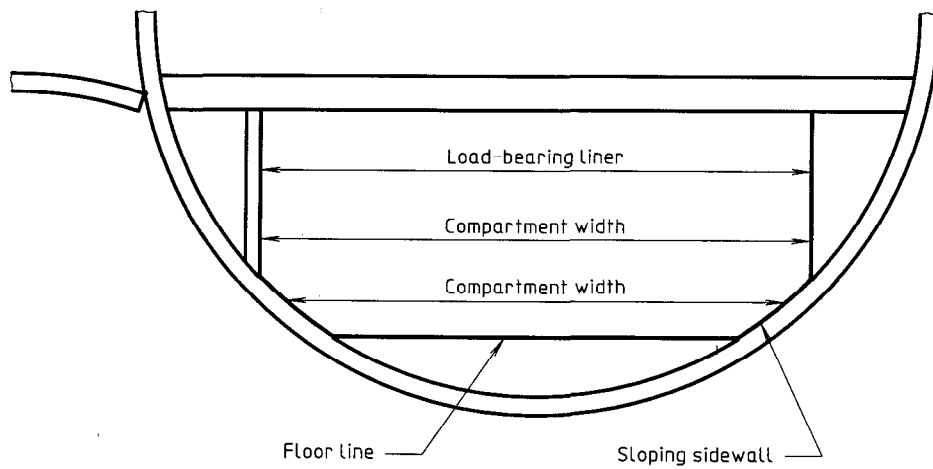
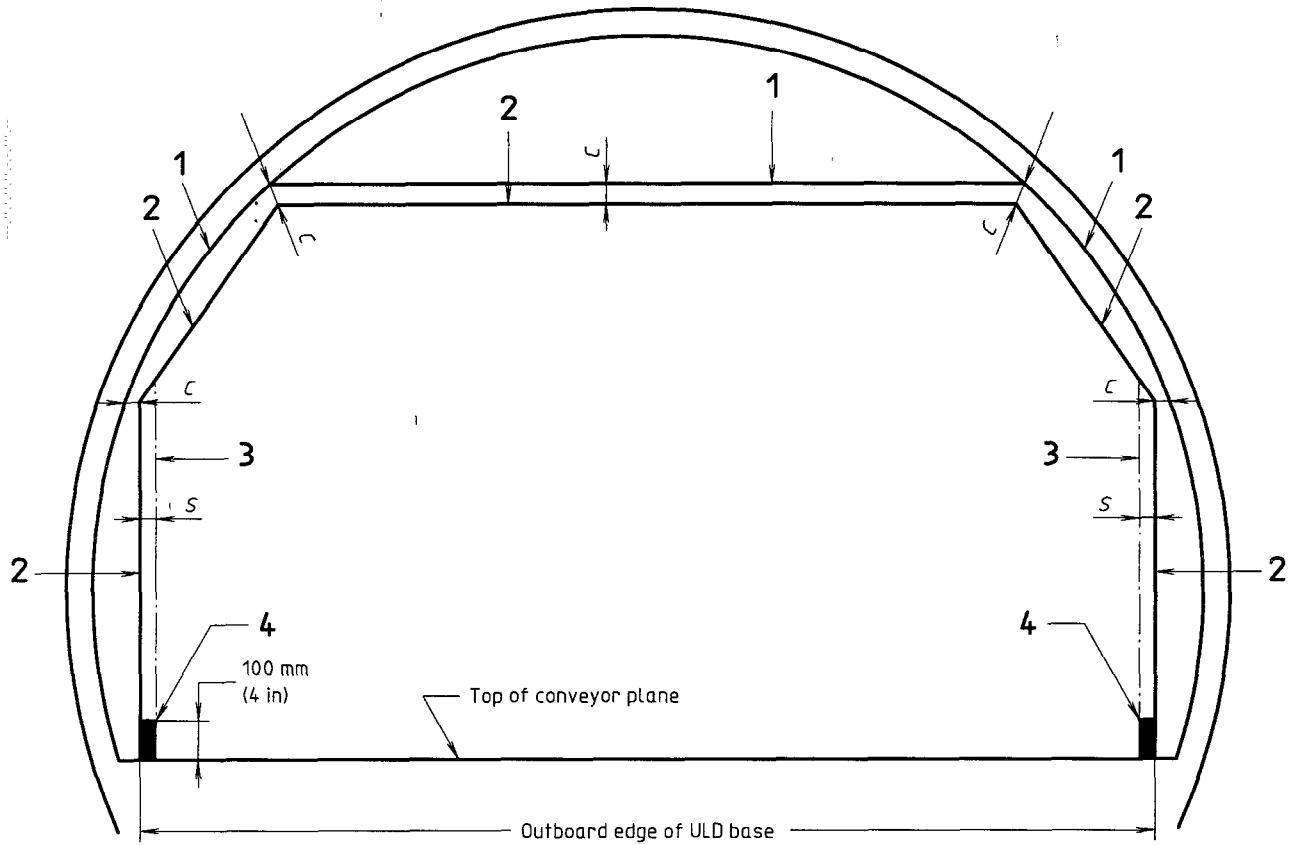
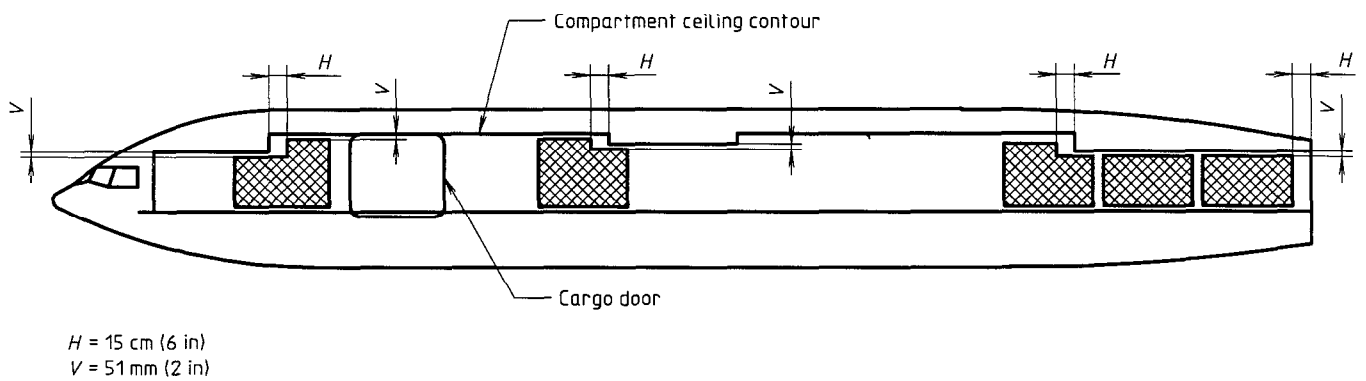

Figure 6 — Lower deck compartment usable width



- 1 Minimum aircraft envelope through which the unit load device must pass
 - 2 Maximum allowable unit load device contour
 - 3 Maximum palletized cargo contour excluding net/hardware, but shall not exceed contour 2.
 - 4 This area (except for ULD base edge) to be left clear for aircraft and ground equipment restraint devices.
- $c = 51 \text{ mm (2 in)}$ minimum clearance
 $s = 51 \text{ mm (2 in)}$ setback for palletized ULD

Figure 7 — Maximum allowable unit load device contour



$H = 15 \text{ cm (6 in)}$
 $V = 51 \text{ mm (2 in)}$

Figure 8 — Palletized cargo contour clearances

ICS 49.120

Descriptors: aircraft, cargo aircraft, aircraft equipment, bay (aeronautics), determination, volume, rules of calculation

Price based on 7 pages
