**Welding — Arc-welded joints in
aluminium and its alloys — Quality levels
for imperfections**

*Soudage — Assemblages en aluminium et alliages d'aluminium soudés
à l'arc — Niveaux de qualité par rapport aux défauts*



PDF disclaimer

This PDF file may contain embedded typefaces. In accordance with Adobe's licensing policy, this file may be printed or viewed but shall not be edited unless the typefaces which are embedded are licensed to and installed on the computer performing the editing. In downloading this file, parties accept therein the responsibility of not infringing Adobe's licensing policy. The ISO Central Secretariat accepts no liability in this area.

Adobe is a trademark of Adobe Systems Incorporated.

Details of the software products used to create this PDF file can be found in the General Info relative to the file; the PDF-creation parameters were optimized for printing. Every care has been taken to ensure that the file is suitable for use by ISO member bodies. In the unlikely event that a problem relating to it is found, please inform the Central Secretariat at the address given below.

© ISO 2005

All rights reserved. Unless otherwise specified, no part of this publication may be reproduced or utilized in any form or by any means, electronic or mechanical, including photocopying and microfilm, without permission in writing from either ISO at the address below or ISO's member body in the country of the requester.

ISO copyright office
Case postale 56 • CH-1211 Geneva 20
Tel. + 41 22 749 01 11
Fax + 41 22 749 09 47
E-mail copyright@iso.org
Web www.iso.org

Published in Switzerland

Contents

Page

Foreword	iv
Introduction	v
1 Scope	1
2 Normative references	1
3 Terms and definitions	2
4 Symbols	3
5 Assessment of imperfections	3
Annex A (informative) Examples of the determination of the percent porosity	16
Annex B (informative) Additional information and guidelines for users of this International Standard	18
Bibliography	19

Foreword

ISO (the International Organization for Standardization) is a worldwide federation of national standards bodies (ISO member bodies). The work of preparing International Standards is normally carried out through ISO technical committees. Each member body interested in a subject for which a technical committee has been established has the right to be represented on that committee. International organizations, governmental and non-governmental, in liaison with ISO, also take part in the work. ISO collaborates closely with the International Electrotechnical Commission (IEC) on all matters of electrotechnical standardization.

International Standards are drafted in accordance with the rules given in the ISO/IEC Directives, Part 2.

The main task of technical committees is to prepare International Standards. Draft International Standards adopted by the technical committees are circulated to the member bodies for voting. Publication as an International Standard requires approval by at least 75 % of the member bodies casting a vote.

Attention is drawn to the possibility that some of the elements of this document may be the subject of patent rights. ISO shall not be held responsible for identifying any or all such patent rights.

ISO 10042 was prepared by Technical Committee ISO/TC 44, *Welding and allied processes*, Subcommittee SC 10, *Unification of requirements in the field of metal welding*.

This second edition cancels and replaces the first edition (ISO 10042:1992), which has been technically revised.

Introduction

This International Standard should be used as a reference in drafting application codes and/or other application standards. It contains a simplified selection of arc welding imperfections based on the designations given in ISO 6520-1.

Some imperfections described in ISO 6520-1 have been used directly and some have been grouped together. The basic numerical referencing system from ISO 6520-1 has been used.

The purpose of this International Standard is to define the dimensions of typical imperfections which might be expected in normal fabrication. It may be used within a quality system for the production of welded joints. It provides three sets of dimensional values from which a selection can be made for a particular application. The quality level necessary in each case should be defined by the application standard or the responsible designer in conjunction with the manufacturer, user and/or other parties concerned. The quality level will have to be prescribed before the start of production, preferably at the enquiry or order stage. For special purposes, additional details may to be prescribed.

The quality levels given in this International Standard provide basic reference data and are not specifically related to any particular application. They refer to the types of welded joint in fabrication and not to the complete product or component itself. It is possible, therefore, that different quality levels are applied to individual welded joints in the same product or component.

It would normally be expected that for a particular welded joint the dimensional limits for imperfections could all be covered by specifying one quality level. In some cases, it may be necessary to specify different quality levels for different imperfections in the same welded joint.

The choice of quality level for any application should take account of design considerations, subsequent processing (e.g. surfacing), mode of stressing (e.g. static, dynamic), service conditions (e.g. temperature, environment) and consequences of failure. Economic factors are also important and should include not only the cost of welding but also of inspection, test and repair.

Although this International Standard includes types of imperfection relevant to the arc welding processes given in Clause 1, only those which are applicable to the process and application in question need to be considered.

Imperfections are quoted in terms of their actual dimensions, and their detection and evaluation may require the use of one or more methods of non-destructive testing. The detection and sizing of imperfections is dependent on the inspection methods and the extent of testing specified in the application standard or contract.

This International Standard does not address the methods used for the detection of imperfections. However, ISO 17635 contains a correlation between the quality level and acceptance level for different NDT methods.

This International Standard is directly applicable to visual examination of welds and does not include details of recommended methods of detection or sizing by other non-destructive means. It should be considered that there are difficulties in using these limits to establish appropriate criteria applicable to non-destructive testing methods such as ultrasonic, radiographic and penetrant testing and they may need to be supplemented by requirements for inspection, examination and testing.

The values given for imperfections are for welds produced using normal welding practice. Requirements for smaller (more stringent) values as stated in quality level B may include additional manufacturing processes, e.g. grinding, TIG dressing.

Requests for official interpretation of any aspect of this International Standard should be directed to the secretariat of ISO/TC 44/SC 10 via your national standards body. A complete listing of these bodies can be found at www.iso.org.

Welding — Arc-welded joints in aluminium and its alloys — Quality levels for imperfections

1 Scope

This International Standard specifies quality levels for imperfections in arc-welded joints in aluminium and its alloys. It applies to material thicknesses above 0,5 mm. It covers full-penetration butt welds and all fillet welds. The principles of this International Standard may also be applied to partial-penetration butt welds.

Quality levels for beam-welded joints are presented in ISO 13919-2.

Three quality levels are given in order to permit application to a wide range of welded constructions. They are designated by symbols B, C and D. Quality level B corresponds to the highest requirement on the finished weld. The quality levels refer to production quality and not to the fitness for purpose (see 3.2) of the product manufactured.

This International Standard applies to:

- all types of weld, e.g. butt welds, fillet welds and branch connections;
- the following welding processes and their sub-processes as defined in ISO 4063:
 - 131 metal inert gas welding (MIG welding); gas metal arc welding /USA/,
 - 141 tungsten inert gas welding (TIG welding); gas tungsten arc welding /USA/,
 - 15 plasma arc welding;
- manual, mechanized and automatic welding;
- all welding positions.

Metallurgical aspects, e.g. grain size, hardness, are not covered by this International Standard.

2 Normative references

The following referenced documents are indispensable for the application of this document. For dated references, only the edition cited applies. For undated references, the latest edition of the referenced document (including any amendments) applies.

ISO 2553, *Welded, brazed and soldered joints — Symbolic representation on drawings*

ISO 4063, *Welding and allied processes — Nomenclature of processes and reference numbers*

ISO 6520-1:1998, *Welding and allied processes — Classification of geometric imperfections in metallic materials — Part 1: Fusion welding*

3 Terms and definitions

For the purposes of this document, the following terms and definitions apply.

3.1 quality level
description of the quality of a weld on the basis of type, size and amount of selected imperfections

3.2 fitness for purpose
ability of a product, process or service to serve a defined purpose under specific conditions

3.3 short imperfections
in cases when the weld is 100 mm long or longer, imperfections are considered to be short imperfections if, in the 100 mm which contains the greatest number of imperfections, their total length is less than 25 mm;

in cases when the weld is less than 100 mm long, imperfections are considered to be short imperfections if their total length is less than 25 % of the length of the weld

3.4 systematic imperfection
imperfection that is repeatedly distributed in the weld over the weld length to be examined, the size of each individual imperfection being within the specified limits

3.5 cross-sectional area
area to be considered after fracture or sectioning

3.6 projected area
area where imperfections distributed along the volume of the weld under consideration are imaged two-dimensionally

NOTE In contrast to the cross-sectional area, the occurrence of imperfections is dependent on the weld thickness when exposed radiographically (see Figure 1).

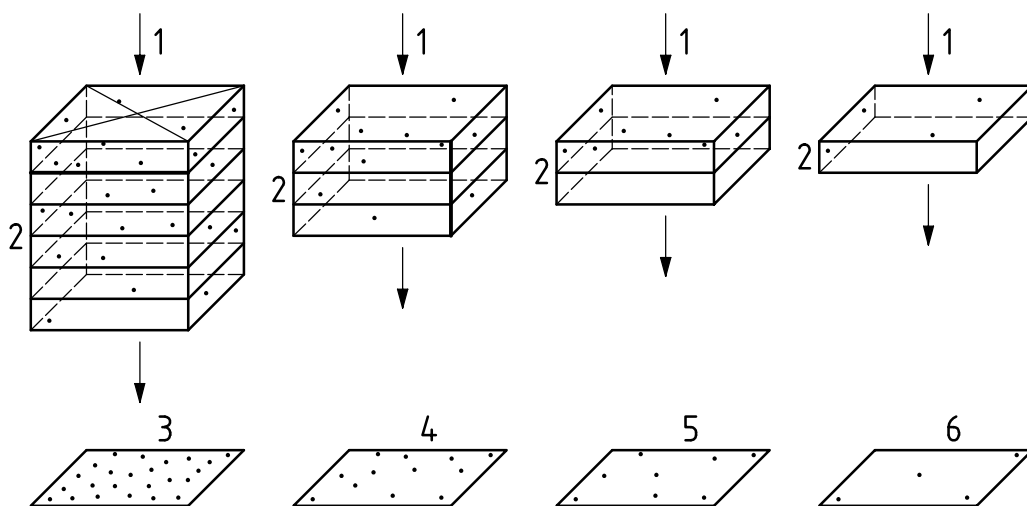

Key
 1 direction of X-rays
 2 4 pores per volume unit
 3 6-fold thickness
 4 3-fold thickness
 5 2-fold thickness
 6 1-fold thickness

Figure 1 — Radiographic films of specimens with identical occurrence of pores per volume unit

4 Symbols

The following symbols are used in Table 1:

- A area surrounding a gas pore
- a nominal throat thickness of a fillet weld (see also ISO 2553)
- b width of weld reinforcement
- d diameter of a gas pore
- d_A diameter of area surrounding a gas pore
- d_{Ac} diameter of circle surrounding total gas pore area
- h height or width of an imperfection
- l length of imperfection in longitudinal direction of weld
- l_p length of projected or cross-sectional area
- s nominal butt weld thickness (see also ISO 2553)
- t wall or plate thickness (nominal size)
- w_p width of weld or width or height of cross-sectional area
- z leg length of a fillet weld (see also ISO 2553)

5 Assessment of imperfections

Limits on imperfections are given in Table 1.

If for the detection of imperfections micro-examination is used, only those imperfections which can be detected with a maximum of ten-fold magnification shall be considered. Excluded from this are microcracks (see Table 1, 2.2).

Systematic imperfections are only permitted in quality level D, provided other requirements of Table 1 are fulfilled.

A welded joint should usually be assessed for each individual type of imperfection separately (see Table 1, 1.1 to 3.2).

Different types of imperfection occurring at any cross-section of the joint need special consideration (see multiple imperfections in Table 1, 4.1).

The limits on multiple imperfections (see Table 1) are only applicable in cases where the requirements for a single imperfection are not exceeded.

Any two adjacent imperfections separated by a distance smaller than the major dimension of the smaller imperfection shall be considered as a single imperfection.

Table 1 — Limits on imperfections

No.	Reference No. in ISO 6520-1:1998	Designation of imperfection	Remarks	<i>t</i> mm	Limits on imperfections for quality levels			
					D	C	B	B
1 Surface imperfections								
1.1	100	Crack	—	≥ 0,5	Not permitted	Not permitted	Not permitted	Not permitted
1.2	104	Crater crack	<i>h</i> = height or width	≥ 0,5	<i>h</i> ≤ 0,4 _s or 0,4 _a <i>l</i> ≤ 0,4 _s or 0,4 _a	Not permitted	Not permitted	Not permitted
1.3	2012	Uniformly distributed porosity	For the assessment of the porosity, see examples given in Annex A	≥ 0,5	≤ 2 %	≤ 1 %	≤ 0,5 %	

Table 1 (continued)

No.	Reference No. in ISO 6520-1:1998	Designation of imperfection	Remarks	t mm	Limits on imperfections for quality levels		
					D	C	B
1.4	2013	Clustered (localized) porosity	<p>The total gas pore area within the cluster is represented by a circle of diameter d_A surrounding all the gas pores.</p> <p>The requirements for a single gas pore shall be met by all the gas pores within this circle.</p> <p>A permitted porous area shall be local. The possibility of the pore cluster masking other imperfections shall be taken into consideration.</p> <p>If D is less than d_{A1} or d_{A2}, whichever is smaller, then the total gas pore area is represented by a circle of diameter d_{Ac}, where $d_{Ac} = d_{A1} + d_{A2} + D$.</p> <p>Systematic clustered porosity is not permitted.</p>	$\geq 0,5$	$d_A \leq 25$ mm or $d_{A,max} \leq w_p$ d_A corresponds to d_{A1} , d_{A2} or d_{Ac} whichever is applicable	Not permitted	Not permitted

Table 1 (continued)

No.	Reference No. in ISO 6520-1:1998	Designation of imperfection	Remarks	t mm	Limits on imperfections for quality levels		
					D	C	B
1.5	2014	Linear porosity	—	≥ 0,5	Not permitted	Not permitted	Not permitted
1.6	2017	Surface pore	Maximum dimension of a single gas pore:	0,5 to 3 > 3	$d \leq 0,3s$ or $0,3a$ $d \leq 0,4s$ or $0,4a$ max. 3 mm	$d \leq 0,2s$ or $0,2a$ $d \leq 0,3s$ or $0,3a$ max. 1,5 mm	$d \leq 0,1s$ or $0,1a$ $d \leq 0,2s$ or $0,2a$ max. 1 mm
1.7	2025	End crater pipe	—	≥ 0,5	$h \leq 0,4t$ max. 3 mm	$h \leq 0,2t$ max. 1,5 mm	Not permitted
1.8	401	Lack of fusion (incomplete fusion)		≥ 0,5	Short imperfections		Not permitted
1.9	4021	Incomplete root penetration		≥ 0,5	$h \leq 0,1s$ or $0,1a$ max. 3 mm	Not permitted	Not permitted
					Short imperfections, but no systematic imperfections.		Not permitted
					$h \leq 0,2s$ max. 2 mm	Not permitted	Not permitted

Table 1 (continued)

No.	Reference No. in ISO 6520-1:1998	Designation of imperfection	Remarks	t mm	Limits on imperfections for quality levels		
					D	C	B
1.10	5011	Continuous undercut		0,5 to 3	$h \leq 0,2t$	$h \leq 0,1t$	Not permitted
				> 3	$h \leq 0,2t$ but max. 1 mm	$h \leq 0,1t$ but max. 0,5 mm	Not permitted
1.11	5012	Intermittent undercut (short imperfection)	<p>Smooth transition required. 5012 is not regarded as a systematic imperfection.</p>	0,5 to 3	$h \leq 0,2t$	$h \leq 0,1t$	$h \leq 0,1t$
				> 3	$h \leq 0,2t$ but max. 1,5 mm	$h \leq 0,1t$ but max. 1 mm	$h \leq 0,1t$ but max. 0,5 mm
	502	Excess weld metal	<p>Smooth transition required.</p> 	$h \leq 1,5 \text{ mm} + 0,2b$ max. 10 mm	$h \leq 1,5 \text{ mm} + 0,15b$ max. 8 mm	$h \leq 1,5 \text{ mm} + 0,1b$ max. 6 mm	

Table 1 (continued)

No.	Reference No. in ISO 6520-1:1998	Designation of imperfection	Remarks	t mm	Limits on imperfections for quality levels		
					D	C	B
1.12	503	Excessive convexity		$\geq 0,5$	$h \leq 1,5 \text{ mm} + 0,3b$ max. 5 mm	$h \leq 1,5 \text{ mm} + 0,15b$ max. 4 mm	$h \leq 1,5 \text{ mm} + 0,1b$ max. 3 mm
1.13	5213	Insufficient throat thickness	Not applicable to processes proven to give greater depth of penetration. 	$\geq 0,5$	$h \leq 0,3a$ max. 2 mm	$h \leq 0,2a$ max. 1,5 mm	$h \leq 0,1a$ max. 1 mm
1.14	504	Excess penetration		$\geq 0,5$	$h \leq 5 \text{ mm}$	$h \leq 4 \text{ mm}$	$h \leq 3 \text{ mm}$
1.15	506	Overlap		$\geq 0,5$	Short imperfections: $h \leq 0,2b$	Not permitted	Not permitted

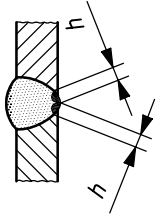
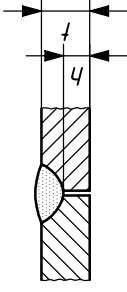
Table 1 (continued)

No.	Reference No. in ISO 6520-1:1998	Designation of imperfection	Remarks	t mm	Limits on imperfections for quality levels		
					D	C	B
1.16	509 511	Sagging Incompletely filled groove	Smooth transition required. 	≥ 0,5	Short imperfections		
					$h \leq 0,2t$ max. 2 mm	$h \leq 0,1t$ max. 1 mm	$h \leq 0,05t$ max. 0,5 mm
1.17	512	Excessive asymmetry of fillet weld (excessively unequal leg length)	In cases where an asymmetric fillet weld has not been specified. 	≥ 0,5	Short imperfections		
					$h \leq 3 \text{ mm} + 0,3a$	$h \leq 2 \text{ mm} + 0,25a$	$h \leq 1,5 \text{ mm} + 0,2a$
1.18	515 5013	Root concavity Shrinkage groove	Smooth transition required. 	≥ 0,5	Short imperfections		
					$h \leq 0,2t$ max. 1,5 mm	$h \leq 0,1t$ max. 1 mm	$h \leq 0,05t$ max. 0,5 mm

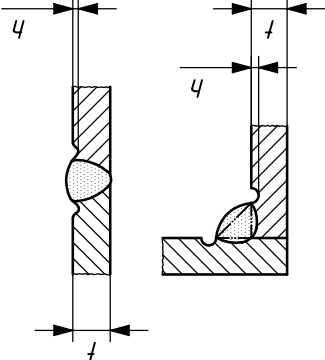
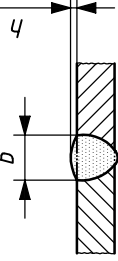
Table 1 (continued)

No.	Reference No. in ISO 6520-1:1998	Designation of imperfection	Remarks	t mm	Limits on imperfections for quality levels			
					D	C	B	A
2 Internal imperfections								
2.1	100	Crack	All types of crack except microcracks and crater cracks.	≥ 0,5	Not permitted	Not permitted	Not permitted	Not permitted
2.2	1001	Microcrack	A crack usually only visible under the microscope (×50)	≥ 0,5	Permitted	Acceptance depends on type of parent metal with particular reference to crack sensitivity		
2.3	2011	Gas pore	Maximum dimension of a single gas pore.	≥ 0,5	$d \leq 0,4_s$ or $0,4_a$ but max. 6 mm	$d \leq 0,3_s$ or $0,3_a$ but max. 5 mm	$d \leq 0,2_s$ or $0,2_a$ but max. 4 mm	
2.4	2012	Uniformly distributed porosity	The assessment of porosity is done with respect to the cross-sectional area. See examples given in Annex A. The assessment of imperfections is done with respect to the projected area. See examples given in Annex A.	≥ 0,5	≤ 6 %	≤ 2 %	≤ 1 %	
				0,5 to 3	≤ 6 %	≤ 2 %	≤ 1 %	
				> 3 to 12	≤ 10 %	≤ 4 %	≤ 2 %	
				> 12 to 30	≤ 15 %	≤ 6 %	≤ 3 %	
				> 30	≤ 20 %	≤ 8 %	≤ 4 %	

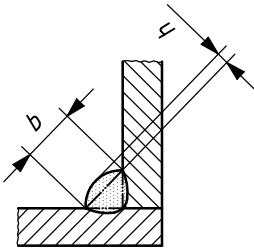
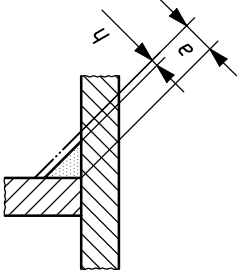
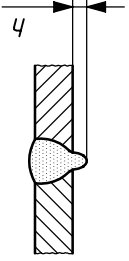
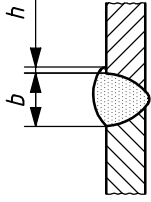
Table 1 (continued)

No.	Reference No. in ISO 6520-1:1998	Designation of imperfection	Remarks	t mm	Limits on imperfections for quality levels		
					D	C	B
2.5	2013	Clustered (localized) porosity	<p>The total gas pore area within the cluster is represented by a circle of diameter d_A surrounding all the gas pores.</p> <p>The requirements for a single gas pore shall be met by all the gas pores within this circle.</p> <p>A permitted porous area shall be local. The possibility of the pore cluster masking other imperfections shall be taken into consideration.</p> <p>If D is less than d_{A1} or d_{A2}, whichever is smaller, then the total gas pore area is represented by a circle of diameter d_{AC}, where $d_{AC} = d_{A1} + d_{A2} + D$.</p> <p>Systematic clustered porosity is not permitted.</p>	$\geq 0,5$	$d_A \leq 25$ mm or $d_{A,max} \leq w_p$	$d_A \leq 20$ mm or $d_{A,max} \leq w_p$	$d_A \leq 15$ mm or $d_{A,max} \leq w_p/2$

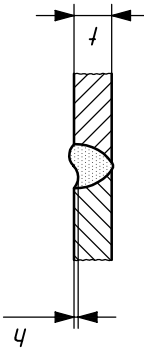
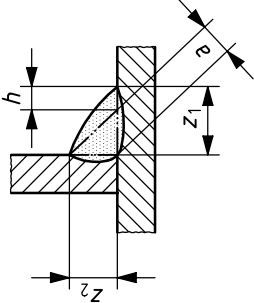
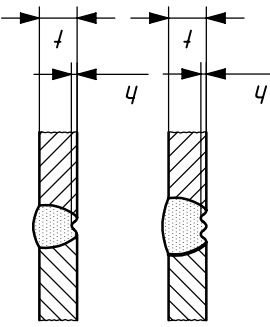
Table 1 (continued)

No.	Reference No. in ISO 6520-1:1998	Designation of imperfection	Remarks	l mm	Limits on imperfections for quality levels		
					D	C	B
2.6	2014	Linear porosity	—	≥ 0,5	Short imperfections permitted	Not permitted	
2.7	2015 2016	Elongated cavity Wormhole	—	≥ 0,5	$l \leq 0,4_s$ or $0,4a$ but max. 6 mm	$l \leq 0,3_s$ or $0,3a$ but max. 4 mm	$l \leq 0,2_s$ or $0,2a$ but max. 3 mm
2.8	303	Oxide inclusion	If several oxide inclusions $l_1, l_2, l_3, \dots, l_n$ exist in one cross-section, they are summed: $l = l_1 + l_2 + l_3 + \dots + l_n$.	≥ 0,5	Short imperfections		
					$l \leq s$ or a max. 10 mm	$l \leq 0,5_s$ or $0,5a$ max. 5 mm	$l \leq 0,2_s$ or $0,2a$ max. 3 mm
2.9	3041	Tungsten inclusion	—	≥ 0,5	$l \leq 0,4_s$ or $0,4a$ but max. 6 mm	$l \leq 0,3_s$ or $0,3a$ but max. 4 mm	$l \leq 0,2_s$ or $0,2a$ but max. 3 mm
2.10	401	Lack of fusion (incomplete fusion)		≥ 0,5	Short imperfections permitted $h \leq 0,3_s$ or $0,3a$ but max. 3 mm		
						Not permitted	Not permitted

Table 1 (continued)

No.	Reference No. in ISO 6520-1:1998	Designation of imperfection	Remarks	t mm	Limits on imperfections for quality levels			
					D	C	B	
2.11	402	Lack of penetration (incomplete penetration)		≥ 0,5	$h \leq 0,4s$ max. 3 mm	$h \leq 0,2s$ max. 2 mm	Not permitted	
2.12	—	Lack of penetration (incomplete penetration) for fillet welds		≥ 0,5	$h \leq 0,3a$ max. 2 mm	$h \leq 0,2a$ max. 1,5 mm	$h \leq 0,1a$ max. 1 mm	

Table 1 (continued)

No.	Reference No. in ISO 6520-1:1998	Designation of imperfection	Remarks	t mm	Limits on imperfections for quality levels		
					D	C	B
3 Imperfections in joint geometry							
3.1	507	Linear misalignment	<p>The limits relate to deviations from the correct position. Unless otherwise specified, the correct position is that when the centrelines coincide (see also Clause 1). t refers to the smaller thickness.</p> 	≥ 0,5	$h \leq 0,4t$ max. 8 mm	$h \leq 0,3t$ max. 4 mm	$h \leq 0,2t$ max. 2 mm
			Plates and longitudinal welds		$h \leq 0,4t$ max. 10 mm	$h \leq 0,3t$ max. 6 mm	$h \leq 0,2t$ max. 4 mm
			Circumferential welds				

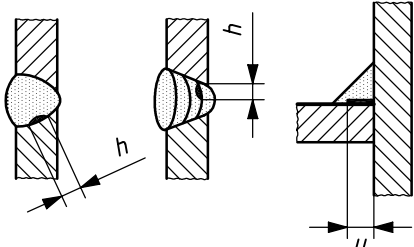
Table 1 (continued)

No.	Reference No. in ISO 6520-1:1998	Designation of imperfection	Remarks	t mm	Limits on imperfections for quality levels		
					D	C	B
3.2	617	Incorrect root gap for fillet welds	<p>Gap between the parts to be joined.</p>  <p>Gaps exceeding the relevant limit may in certain cases be compensated for by a corresponding increase in the throat thickness.</p>	$h \leq 1 \text{ mm} + 0,2a$ max. 5 mm	$h \leq 0,5 \text{ mm} + 0,15a$ max. 4 mm	$h \leq 0,5 \text{ mm} + 0,1a$ max. 3 mm	
4 Multiple imperfections							
4.1	—	Multiple imperfections in any cross-section	 	$\geq 0,5$	The sum of the acceptable individual imperfections in any cross-section shall not exceed: $0,4t$ or $0,4a$ $0,3t$ or $0,3a$ $0,2t$ or $0,2a$		

Annex A (informative)

Examples of the determination of the percent porosity

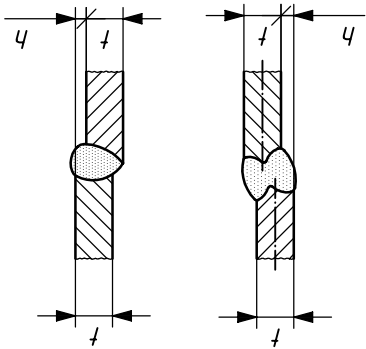
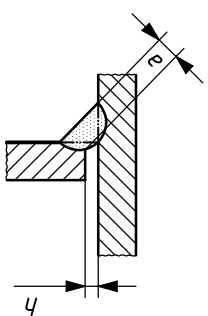
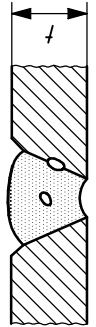
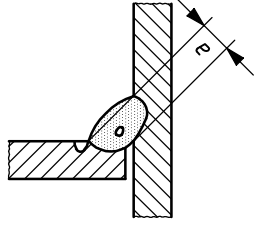
Figures A.1 to A.10 illustrate different percent (%) porosities. They are intended to assist in the assessment of porosity in projected areas (radiographs) or in cross-sectional areas.

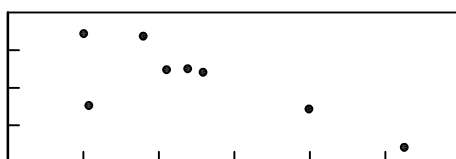

Figure A.1 — 0,5 %

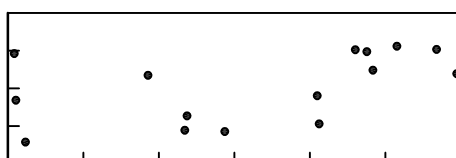

Figure A.2 — 1 %

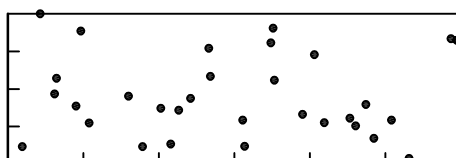

Figure A.3 — 2 %

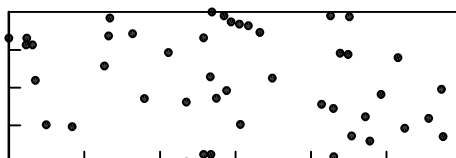

Figure A.4 — 3 %

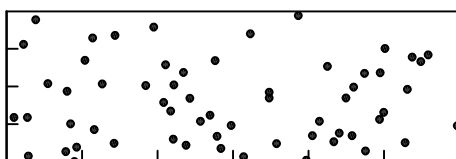

Figure A.5 — 4 %

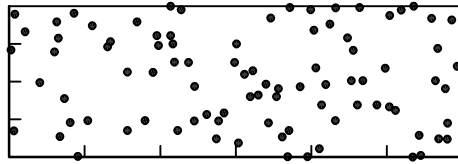

Figure A.6 — 6 %

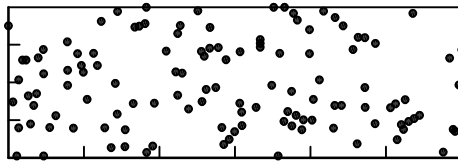

Figure A.7 — 8 %

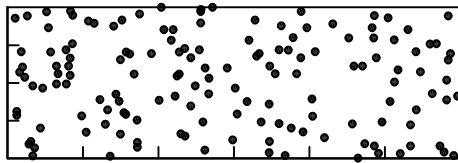

Figure A.8 — 10 %

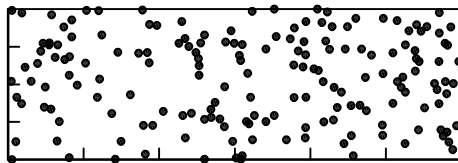

Figure A.9 — 15 %

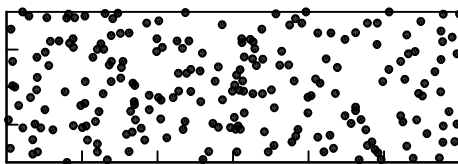

Figure A.10 — 20 %

Annex B (informative)

Additional information and guidelines for users of this International Standard

This International Standard specifies requirements for three quality levels for imperfections in welded joints of aluminium and its alloys produced by arc welding processes (beam welding excluded), as specified in the scope, and for weld thicknesses $\geq 0,5$ mm. It may be used, where applicable, for other arc welding processes and weld thicknesses.

Components are very often produced for different applications, but to similar requirements. The same requirements should, however, apply to identical components produced in different workshops to ensure that work is carried out using the same criteria. The consistent application of this International Standard is one of the fundamental cornerstones of a quality assurance system for use in the production of welded structures.

When summing multiple imperfections, there is a theoretical possibility of individual imperfections being superimposed. In such a case, the summation of all permitted deviations should be restricted by the values specified for the various imperfections, i.e. the limit for a single imperfection, e.g. a single pore, should not be exceeded.

This International Standard may be used in conjunction with a catalogue of realistic illustrations showing the sizes of the permissible imperfections for the various quality levels by means of photographs showing the face and root side and/or reproductions of radiographs and of photomicrographs showing the cross-section of the weld. An example of such a catalogue is *Reference radiographs for the assessment of weld imperfections according to ISO 10042*^[3]. This catalogue may be used with reference cards to assess the various imperfections and may be employed when opinions differ as to the permissible size of imperfections.

Bibliography

- [1] ISO 13919-2, *Welding — Electron and laser beam welded joints — Guidance on quality levels for imperfections — Part 2: Aluminium and its weldable alloys*
- [2] ISO 17635, *Non-destructive testing of welds — General rules for fusion welds in metallic materials*
- [3] *Reference radiographs for the assessment of weld imperfections according to ISO 10042*, published by the International Institute of Welding (IIW) and Deutscher Verlag für Schweißen und verwandte Verfahren, Düsseldorf

