

---

---

**Hydraulic fluid power — Method  
for evaluating the buckling load of a  
hydraulic cylinder**

*Transmissions hydrauliques — Méthode d'évaluation du flambage  
d'un vérin*



**COPYRIGHT PROTECTED DOCUMENT**

© ISO 2016, Published in Switzerland

All rights reserved. Unless otherwise specified, no part of this publication may be reproduced or utilized otherwise in any form or by any means, electronic or mechanical, including photocopying, or posting on the internet or an intranet, without prior written permission. Permission can be requested from either ISO at the address below or ISO's member body in the country of the requester.

ISO copyright office  
Ch. de Blandonnet 8 • CP 401  
CH-1214 Vernier, Geneva, Switzerland  
Tel. +41 22 749 01 11  
Fax +41 22 749 09 47  
copyright@iso.org  
www.iso.org

# Contents

Page

<b>Foreword</b> .....	<b>iv</b>
<b>Introduction</b> .....	<b>v</b>
<b>1 Scope</b> .....	<b>1</b>
<b>2 Symbols and units</b> .....	<b>1</b>
2.1 General.....	1
2.2 Additional notations.....	2
<b>3 General principles</b> .....	<b>3</b>
3.1 Purpose.....	3
3.2 Description.....	3
3.3 Dimensional layout of hydraulic cylinder.....	3
3.4 Common calculation of maximum stress in the rod (for all mounting types) $\sigma_{\max}$ .....	5
3.4.1 Deflexion curve.....	6
3.4.2 Bending moment.....	6
3.4.3 Maximum value of the bending moment.....	6
3.4.4 Maximum stress of the piston rod.....	7
3.4.5 Mounting types of the cylinder tube and piston rod.....	7
<b>4 Case of pin-mounted hydraulic cylinders</b> .....	<b>8</b>
4.1 Model of the hydraulic cylinder and unknown values.....	8
4.2 Linear system.....	9
4.3 Critical buckling load.....	9
4.4 Greatest allowable compressive load.....	10
<b>5 Case of hydraulic cylinders fixed at the beginning of the cylinder tube and pin mounted at the end of the piston rod</b> .....	<b>10</b>
5.1 Critical buckling load.....	10
5.2 Linear system.....	10
<b>6 Case of hydraulic cylinders pin mounted at the beginning of the cylinder tube and fixed at the end of the piston rod</b> .....	<b>11</b>
6.1 Critical buckling load.....	11
6.2 Linear system.....	11
<b>7 Case of hydraulic cylinders fixed at both ends</b> .....	<b>12</b>
7.1 Critical buckling load.....	12
7.2 Linear system.....	12
<b>8 Case of hydraulic cylinders fixed at the beginning of the cylinder tube and free at the end of the piston rod</b> .....	<b>13</b>
8.1 Critical buckling load.....	13
8.2 Linear system.....	14
<b>9 Case of hydraulic cylinders fixed at both ends with free movement allowed at the end of the piston rod</b> .....	<b>15</b>
9.1 Critical buckling load.....	15
9.2 Linear system.....	15
<b>Annex A (informative) Example of numerical results</b> .....	<b>17</b>
<b>Bibliography</b> .....	<b>19</b>

## Foreword

ISO (the International Organization for Standardization) is a worldwide federation of national standards bodies (ISO member bodies). The work of preparing International Standards is normally carried out through ISO technical committees. Each member body interested in a subject for which a technical committee has been established has the right to be represented on that committee. International organizations, governmental and non-governmental, in liaison with ISO, also take part in the work. ISO collaborates closely with the International Electrotechnical Commission (IEC) on all matters of electrotechnical standardization.

The procedures used to develop this document and those intended for its further maintenance are described in the ISO/IEC Directives, Part 1. In particular the different approval criteria needed for the different types of ISO documents should be noted. This document was drafted in accordance with the editorial rules of the ISO/IEC Directives, Part 2 (see [www.iso.org/directives](http://www.iso.org/directives)).

Attention is drawn to the possibility that some of the elements of this document may be the subject of patent rights. ISO shall not be held responsible for identifying any or all such patent rights. Details of any patent rights identified during the development of the document will be in the Introduction and/or on the ISO list of patent declarations received (see [www.iso.org/patents](http://www.iso.org/patents)).

Any trade name used in this document is information given for the convenience of users and does not constitute an endorsement.

For an explanation on the meaning of ISO specific terms and expressions related to conformity assessment, as well as information about ISO's adherence to the WTO principles in the Technical Barriers to Trade (TBT) see the following URL: [Foreword - Supplementary information](#)

The committee responsible for this document is ISO/TC 131, *Fluid power systems*, Subcommittee SC 3, *Cylinders*.

This second edition cancels and replaces the first edition (ISO/TS 13725:2001), which has been technically revised.

## Introduction

Historically, cylinder manufacturers in the fluid power industry have experienced very few rod buckling failures, most likely due to the use of adequately conservative design factors employed during cylinder design and to the recommendation of factors of safety to the users. Many countries and some large companies have developed their own methods for evaluating buckling load.

The method presented in this Technical Specification has been developed to comply with the requirements formulated by ISO/TC 131.



# Hydraulic fluid power — Method for evaluating the buckling load of a hydraulic cylinder

## 1 Scope

This document specifies a method for the evaluation of the buckling load which

- a) takes into account a geometric model of the hydraulic cylinder, meaning it does not treat the hydraulic cylinder as an equivalent column,
- b) can be used for all types of cylinder mounting and rod end connection specified in [Table 2](#),
- c) includes a factor of safety,  $k$ , to be set by the person performing the calculations and reported with the results of the calculations,
- d) takes into account possible off-axis loading,
- e) takes into account the weight of the hydraulic cylinder, meaning it does not neglect all transverse loads applied on the hydraulic cylinder,
- f) can be implemented as a simple computer program, and
- g) considers the cylinder fully extended.

The method specified is based on the elastic buckling theory and is applicable to single and double acting cylinders that conform to ISO 6020 (all parts), ISO 6022 and ISO 10762. If necessary, finite element analyses can be used to verify as well as to determine the buckling load.

The method is not developed for thin-walled cylinders, double-rods or plunger cylinders.

The method is not developed for internal (rod) buckling.

The friction of spherical bearings is not taken into account.

NOTE This method is based mainly on original work by Fred Hoblit.<sup>[2]</sup> This method has been established in reference to the standard NF PA/T3.6.37.<sup>[1]</sup>

## 2 Symbols and units

### 2.1 General

The symbols and units used in this document are given in [Table 1](#). See [Figures 1](#) and [2](#) for labels of dimensions and other characteristics.

**Table 1 — Symbols and units**

Symbol	Meaning	Unit
$C$	stiffness of a possible transverse support at the free end of the piston rod	N/mm
$D_{1e}$	outside diameter of the cylinder tube	mm
$D_{1i}$	inside diameter of the cylinder tube	mm
$D_2$	outside diameter of the piston rod	mm
$e_w, e_d$	distance where the loading of an eccentrically loaded column is equivalent to a concentric axial force $F$ and end moment $M = F [x] e$	mm
$E_1$	modulus of elasticity of cylinder tube material	N/mm <sup>2</sup>

Table 1 (continued)

Symbol	Meaning	Unit
$E_2$	modulus of elasticity of piston rod material	N/mm <sup>2</sup>
$F$	maximum allowable compressive axial load; modified by the factor of safety, (see $k$ below), it creates in the piston rod a maximum stress equal to the yield stress of the piston rod material	N
$F_{critical}$	Euler buckling load of the cylinder	N
$I_1$	moment of inertia of the cylinder tube	mm <sup>4</sup>
$I_2$	moment of inertia of the piston rod	mm <sup>4</sup>
$k$	factor of safety [see <a href="#">Clause 1, c</a> ]	—
$L_1$	cylinder tube length (in accordance with <a href="#">Figure 1</a> )	mm
$L_2$	piston rod length (in accordance with <a href="#">Figure 1</a> )	mm
$L_3$	length of the portion of rod situated inside the cylinder tube, i.e. the distance between the centre points of the piston and the piston rod bearing (in accordance with <a href="#">Figure 1</a> ) with the rod fully extended	mm
$L_p$	length of the piston	mm
$M_a$	fixed-end moment at the beginning of the cylinder tube of a fixed hydraulic cylinder	N·mm
$M_{bc}$	moment at the junction of cylinder tube and piston rod	N·mm
$M_d$	fixed-end moment at the end of the piston rod of a fixed hydraulic cylinder	N·mm
$M_{max}$	maximum moment in the piston rod	N·mm
$R_a$	reaction at the beginning of the cylinder tube	N
$R_d$	reaction at the end of the piston rod	N
$R_{bc}$	reaction between cylinder tube and position rod	N
$X$	distance from the end of a beam	mm
$Y$	deflection of a slender beam at distance $x$	mm
$G$	gravitational acceleration	mm/s <sup>2</sup>
$\Delta$	elongation of the possible transverse support at the free end of the piston rod	mm
$\theta$	angle (crookedness) between the deflection curve of the cylinder tube and the deflection curve of the piston rod (see <a href="#">Figure 2</a> )	rad
$\rho_1$	mass per unit volume of cylinder tube material	kg/mm <sup>3</sup>
$\rho_2$	mass per unit volume of piston rod material	kg/mm <sup>3</sup>
$\sigma$	stress	N/mm <sup>2</sup>
$\sigma_e$	yield point of a material	N/mm <sup>2</sup>
$\sigma_{max}$	maximum compressive stress	N/mm <sup>2</sup>
$\varphi_a$	angle of the deflection curve at the beginning of the cylinder tube	rad
$\varphi_b$	angle of the deflection curve at the end of the cylinder tube	rad
$\varphi_c$	angle of the deflection curve at the beginning of the piston rod	rad
$\varphi_d$	angle of the deflection curve at the end of the piston rod	rad
$\psi_a$	angle at the beginning of the cylinder tube (see <a href="#">Figure 2</a> )	rad
$\psi_d$	angle at the end of the piston rod (see <a href="#">Figure 2</a> )	rad

## 2.2 Additional notations

The following additional notations are also used in this document:

$$s_1 = \sin (q_1 L_1) \quad (1)$$

$$c_1 = \cos (q_1 L_1) \quad (2)$$



$$s_2 = \sin (q_2 L_2) \quad (3)$$

$$c_2 = \cos (q_2 L_2) \quad (4)$$

$$q_1 = \sqrt{\frac{k \times F}{E_1 \times I_1}} \quad (5)$$

$$q_2 = \sqrt{\frac{k \times F}{E_2 \times I_2}} \quad (6)$$

NOTE The origin of these notations (used for calculation) comes from the original work of Hoblit (see Reference 2).

### 3 General principles

#### 3.1 Purpose

The cylinder is a system consisting of three parts (Figure 2). Two parts, the cylinder tube and the rod outside of the tube, are considered as columns. This system is subject to compressive forces ( $F$ ,  $-F$ ). The third part is the connection between these two parts in the form of the small piece of the rod inside the tube and is modelled as a rotational spring. The purpose of this Technical Specification is to determine the maximum allowable force,  $F_{\max}$ , that avoids reaching yield stress of the rod material,  $\sigma_e$ , as well as buckling.

#### 3.2 Description

The cylinder is in static equilibrium. The cylinder is subjected to a deformation due to the compression forces ( $F$ ,  $-F$ ). This deformation is identified for each of the three parts of the cylinder by geometric unknowns (angles) and static unknowns (forces, moments) and a specific relation (Hoblit model) due to the rotational spring joining the cylinder tube and the rod.

Based on considerations of equilibrium and kinematics, a set of equations is formulated. The type of fixations (e.g. pin-mounted or fixed at the two ends) defines the number of unknown values (from 9 to 13). There are as many equations as unknown values. Six types of fixation are treated (Table 2).

The system of equations can be solved for an  $F$  value previously set. However, it is important to establish a particular value of  $F$ , noted  $F_{critical}$ .  $F_{critical}$  cancels the determinant of the system of equations. This value should not be reached because it leads to an infinite value of the maximum stress of the rod ( $\sigma_{\max}$ ).

It is therefore necessary to find the value of  $F$  ( $F_{\max}$ ) between the zero value (in fact  $\varepsilon \cdot F_{critical}$ ) and  $F_{critical}$  (in fact  $[1 - \varepsilon] \cdot F_{critical}$ ) that leads the stress in the rod to reach the yield stress of the rod material (when  $\sigma_{\max} = \sigma_e$ ).

NOTE  $\varepsilon$  is a seed value used in the method of proportional parts to solve the set of equations.

#### 3.3 Dimensional layout of hydraulic cylinder

Figures 1 and 2 depict the variables and principles used within this Technical Specification.

In the event that the external load  $F$  on the cylinder is at its maximum with the rod fully extended, the worst case occurs when the cylinder is in the horizontal position. In this case, the maximum allowable compressive load is at its lowest and creates the maximum stress in the piston rod. For this reason, and also considering the way of calculation where  $L_3$  is insignificant compared with  $L_1$  and  $L_2$ ,  $L_3$  is the shortest distance between the two centre points of the piston and the bearing.

When an almost retracted cylinder is loaded with a pushing force, there might be a risk of internal buckling of the rod. Therefore, the rod is to be calculated separately if this is regarded as a risk.

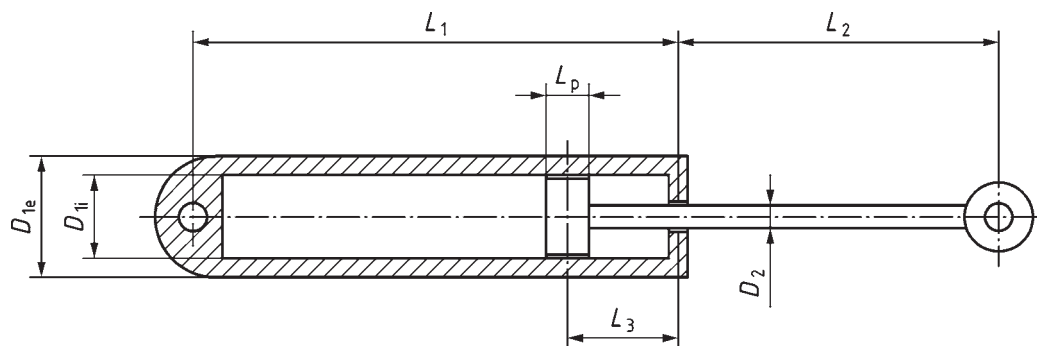

NOTE  $L_3 = \frac{(L_p + \frac{(D_{1e} - D_{1i})}{2})}{2}$  is a possible minimum value of  $L_3$ .

Figure 1 — Cylinder

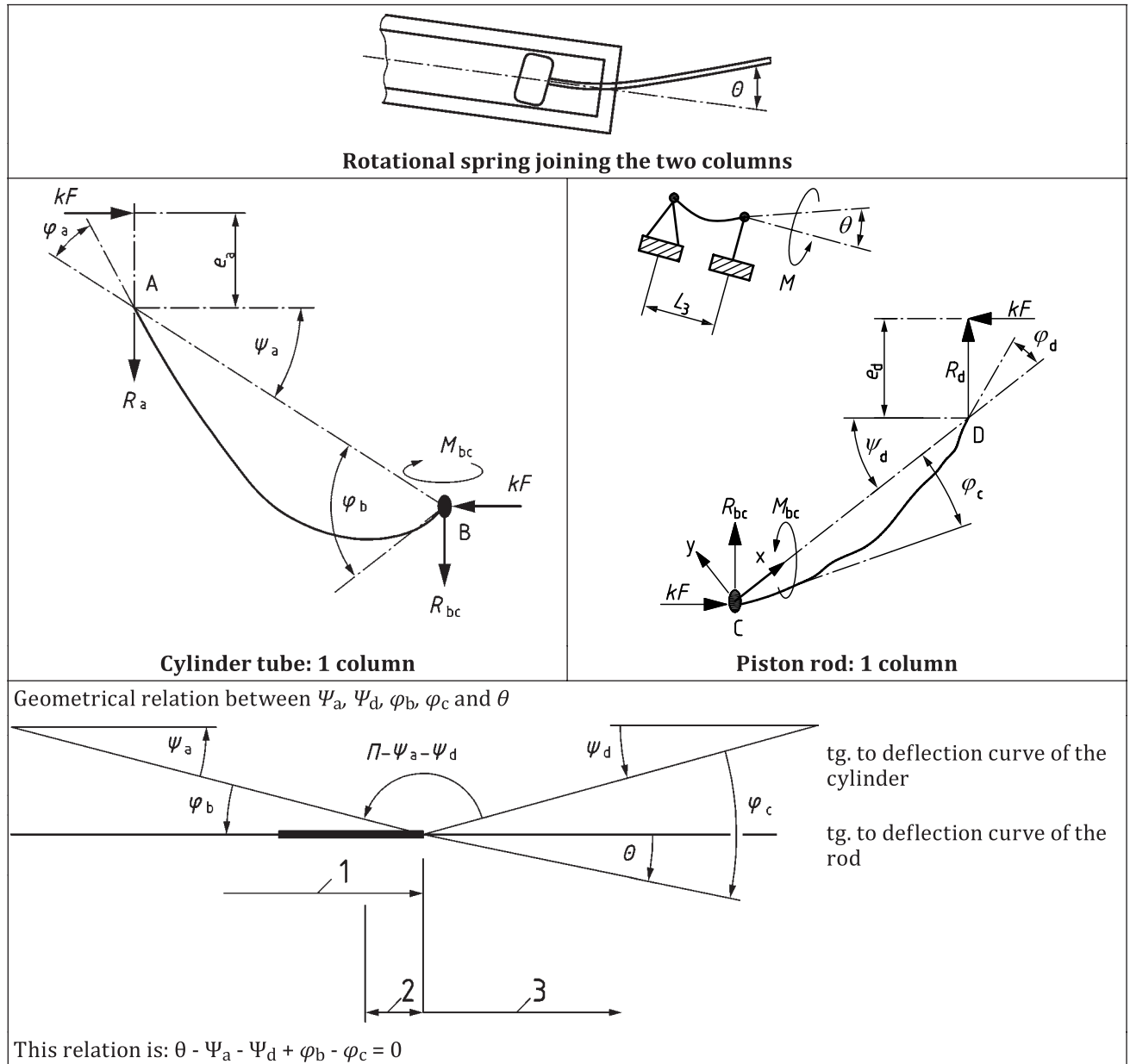

Figure 2 — Model of the hydraulic cylinder

### 3.4 Common calculation of maximum stress in the rod (for all mounting types) $\sigma_{max}$

The piston rod can be considered as the critical part of the cylinder if the thickness of the cylinder tube is sufficient. This condition should be verified before applying the generic method.

**3.4.1 Deflexion curve**

The local deflexion curve ( $x$ -axis is the line joining points C and D in [Figure 2](#)) of the rod, common for all cases of fixations, is given by the following equation:

$$y(x) = C_1 \sin(q_2 x) + C_2 \cos(q_2 x) + C_3 x^2 + C_4 x + C_5 \tag{7}$$

where

$$C_1 = \frac{1}{kFs_2} \left( -R_{bc} L_2 + \left( -M_{bc} + \frac{\rho_2 \pi D_2^2 g}{4q_2^2} \right) (c_2 - 1) + kFL_2 \psi_d + \frac{\rho_2 \pi D_2^2 g L_2^2}{8} \right) \tag{8}$$

$$C_2 = -\frac{1}{kF} \left( -M_{bc} + \frac{\rho_2 \pi D_2^2 g}{4q_2^2} \right) \tag{9}$$

$$C_3 = -\frac{\rho_2 \pi D_2^2 g}{8kF} \tag{10}$$

$$C_4 = \frac{R_{bc} - kF\psi_d}{kF} \tag{11}$$

$$C_5 = \frac{1}{kF} \left( -M_{bc} + \frac{\rho_2 \pi D_2^2 g}{4q_2^2} \right) \tag{12}$$

**3.4.2 Bending moment**

The bending moment in the rod at distance  $x$  of the junction between cylinder tube and piston rod (i.e. point C) is:

$$M(x) = E_2 I_2 \left( \frac{d^2 y}{dx^2} \right) = -\frac{\rho_2 \pi D_2^2 g}{8} x^2 + (R_{bc} - kF\psi_d)x - M_{bc} - kFy(x) \tag{13}$$

**3.4.3 Maximum value of the bending moment**

This moment has a maximum at distance  $x_{m\_max}$ , which satisfies one of the following conditions:

$$x_{m\_max} = 0 \tag{14}$$

$$0 < x_{m\_max} < L_2 \text{ and } x_{m\_max} = \frac{\left( \arctan\left(\frac{C_1}{C_2}\right) + n\pi \right)}{q_2} \left( \Leftrightarrow \frac{d^3 y}{dx^3} = 0 \right) \tag{15}$$

$$x_{m\_max} = L_2 \tag{16}$$

At this distance, the value  $M_{max}$  of the bending moment is evaluated using [Formulae \(7\)](#) and [\(13\)](#).

### 3.4.4 Maximum stress of the piston rod

If shear stress is not taken into account, the maximum stress occurs where the bending moment is at its maximum,  $M_{\max}$ :

$$\sigma_{\max} = \frac{4kF}{\pi D_2^2} + \frac{32M_{\max}}{\pi D_2^3} \quad (17)$$

$\sigma_{\max}$  is a function of  $F$  [ $\sigma_{\max}(F)$ ]. The other part of the calculation is to find the maximum value of  $F$ ,  $F_{\max}$  which meets the elastic condition  $\sigma_{\max} < \sigma_e$  (see 3.1).

To establish  $F_{\max}$ , it is necessary to solve equations of equilibrium with unknown values for each mounting case (see 3.2 as well as Clauses 4 to 9).

### 3.4.5 Mounting types of the cylinder tube and piston rod

The generic method to be used is specified below. Some of the equations specified depend on the type of fixation of the cylinder tube and of the piston rod.

The different cases are given in Table 2.

Table 2 — Mounting types

Mounting types	Method
	Pin-mounted hydraulic cylinders. See Clause 4 (completely treated).
	Hydraulic cylinders fixed at the beginning of the cylinder tube and pin-mounted at the end of the piston rod. See Clause 5.
	Hydraulic cylinders pin mounted at the beginning of the cylinder tube and fixed at the end of the piston rod. See Clause 6.

Table 2 (continued)

Mounting types	Method
	Hydraulic cylinders fixed at their two ends. See <a href="#">Clause 7</a> .
	Hydraulic cylinders fixed at the beginning of the cylinder tube and free at the end of the piston rod. See <a href="#">Clause 8</a> .
	Hydraulic cylinders fixed at their two ends with a free move allowed at the end of the piston rod. See <a href="#">Clause 9</a> .

Specific mounting cases as head flange, side lugs, intermediately fixed or movable trunnion are not taken into account in [Table 2](#).

## 4 Case of pin-mounted hydraulic cylinders

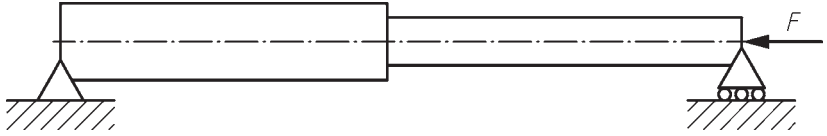
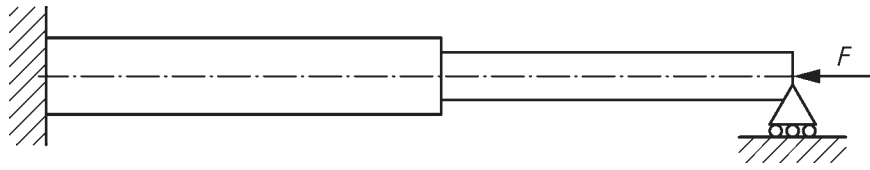
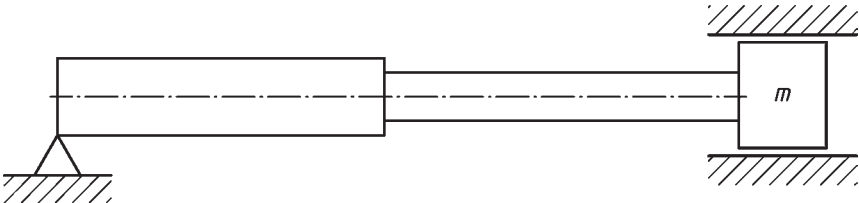
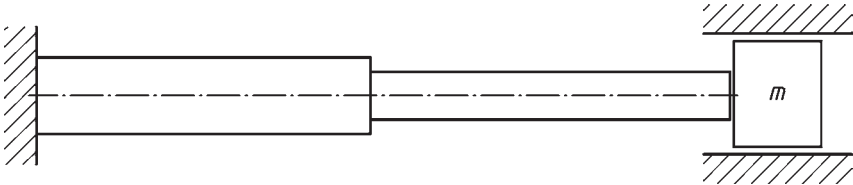
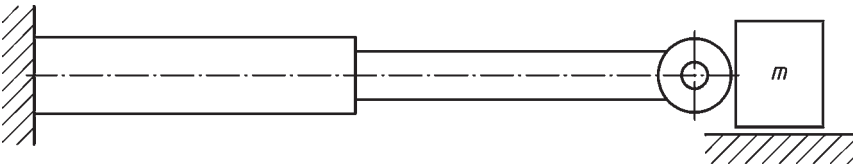
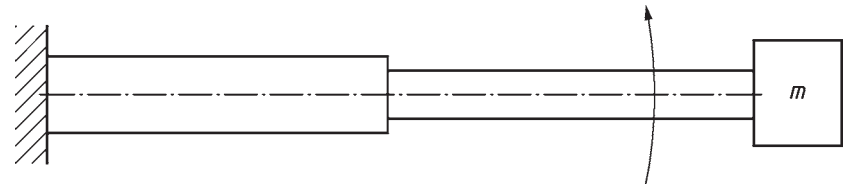
### 4.1 Model of the hydraulic cylinder and unknown values

According to the proposal of Hoblit, the hydraulic cylinder is treated as the set of columns in accordance with [Figure 2](#).

Nine unknown values appear in this model:

- reactions  $R_a, R_{bc}, R_d$
- moment  $M_{bc}$
- crookedness angle  $\theta$  between the deflection curve of the cylinder tube and the deflection curve of the piston rod
- angles  $\psi_a, \psi_d, \varphi_b, \varphi_c$

Those unknown values shall satisfy a set of nine algebraic equations whose coefficients are functions of the axial load  $kF$  where  $k$  is a factor of safety.

Those equations are:

- geometrical compatibility condition that links angles  $\psi_a$  and  $\psi_d$ : 1 equation
- geometrical relationship between angles  $\psi_a, \psi_d, \varphi_b, \varphi_c$  and  $\theta$  at the connection between cylinder and piston rod: 1 equation
- relationship that links moment  $M_{bc}$  and  $\theta$  to render the sliding connection between the cylinder and the piston rod: 1 equation
- equilibrium of column AB (cylinder tube): 2 equations that links  $R_a, R_{bc}, M_{bc}, \psi_a$
- equilibrium of column CD (piston rod): 2 equations that links  $R_d, R_{bc}, M_{bc}, \psi_d$
- deflection of column AB: 1 equation that links  $R_{bc}, M_{bc}, \psi_a$  and  $\varphi_b$

— deflection of column CD: 1 equation that links  $R_{bc}$ ,  $M_{bc}$ ,  $\psi_d$  and  $\varphi_c$

NOTE Angles  $\varphi_a$  and  $\varphi_d$  are not unknown values since they can be evaluated as soon as the reactions and moments are determined.

## 4.2 Linear system

Unknown values  $R_a$ ,  $R_{bc}$ ,  $R_d$ ,  $M_{bc}$ ,  $\theta$ ,  $\psi_a$ ,  $\psi_d$ ,  $\varphi_b$ ,  $\varphi_c$  are the solution of the linear system:

$$\begin{bmatrix} 0 & 0 & 0 & 0 & 0 & L_1 & -L_2 & 0 & 0 \\ 0 & 0 & 0 & 0 & 1 & -1 & -1 & 1 & -1 \\ 0 & 0 & 0 & \frac{L_3}{3E_2I_2} & 1 & 0 & 0 & 0 & 0 \\ 1 & 0 & 1 & 0 & 0 & 0 & 0 & 0 & 0 \\ 0 & 0 & L_1 & 1 & 0 & kFL_1 & 0 & 0 & 0 \\ 0 & 0 & q_1L_1 - s_1 & q_1(1 - c_1) & 0 & kF(q_1L_1 - s_1) & 0 & kFs_1 & 0 \\ 0 & 1 & 1 & 0 & 0 & 0 & 0 & 0 & 0 \\ 0 & 0 & -L_2 & 1 & 0 & 0 & kFL_2 & 0 & 0 \\ 0 & 0 & q_2L_2 - s_2 & -q_2(1 - c_2) & 0 & 0 & -kF(q_2L_2 - s_2) & 0 & kFs_2 \end{bmatrix} \quad (18)$$

$$\mathbf{x} \begin{bmatrix} R_a \\ R_d \\ R_{bc} \\ M_{bc} \\ \theta \\ \psi_a \\ \psi_d \\ \varphi_b \\ \varphi_c \end{bmatrix} = \begin{bmatrix} 0 \\ 0 \\ 0 \\ -\rho_1 L_1 \frac{\pi}{4} (D_{1e}^2 - D_{1i}^2) g \\ -\rho_1 L_1^2 \frac{\pi}{8} (D_{1e}^2 - D_{1i}^2) g - kFe_a \\ \frac{\rho_1 \pi (D_{1e}^2 - D_{1i}^2) g q_1}{4} \left( -\frac{L_1^2}{2} + \frac{(1 - c_1)}{q_1^2} \right) \\ \rho_2 L_2 \frac{\pi}{4} D_2^2 g \\ -\rho_2 L_2 \frac{\pi}{8} D_2^2 g - kFe_d \\ \frac{\rho_2 \pi D_2^2 g q_2}{4} \left( \frac{L_2^2}{2} - \frac{(1 - c_2)}{q_2^2} \right) \end{bmatrix} \quad (19)$$

NOTE Solve the linear system with a numerical method in order to define  $M_{\max}$  for each value of  $F$ .

## 4.3 Critical buckling load

The smallest value of  $F$  which vanish the determinant of the linear system is the critical buckling load  $F_{critical}$ :

$$kF_{critical}L_3s_1s_2 - 3E_2I_2q_1c_1s_2 - 3E_2I_2q_2c_2s_1 = 0 \quad (20)$$

#### 4.4 Greatest allowable compressive load

The greatest allowable compressive load  $F_{max}$  is obtained by modifying the value of  $F$  in the previous set of equations (see 4.1) with the method of proportional parts until the stress in the piston rod coming from axial load and bending moment become equal to the yield point of material (see 3.4.4).

### 5 Case of hydraulic cylinders fixed at the beginning of the cylinder tube and pin mounted at the end of the piston rod

#### 5.1 Critical buckling load

Use the following formula to calculate the critical buckling load where  $q, c, s$  values are evaluated from  $F_{critical}$  in accordance with Table 1 and 2.2:

$$kF_{critical}L_3s_2 (L_1q_1c_1 + L_2q_1c_1-s_1) + 3E_2I_2 (L_1 + L_2) q_1 (q_1s_1s_2 - q_2c_1c_2) + 3E_2I_2q_1c_1s_2 + 3E_2I_2q_2c_2s_1 = 0 \quad (21)$$

#### 5.2 Linear system

Use the following set of formulae to calculate the unknowns where  $q, c, s$  values are evaluated from  $F$  in accordance with Table 1 and 2.2:

$$\begin{bmatrix} 0 & 0 & 0 & 0 & 0 & 0 & L_1 & 0 & -L_2 & 0 & 0 \\ 0 & 0 & 0 & 0 & 0 & 1 & -1 & 0 & -1 & 1 & -1 \\ 0 & 0 & 0 & \frac{L_3}{3E_2I_2} & 0 & 1 & 0 & 0 & 0 & 0 & 0 \\ 0 & 0 & 0 & 0 & 0 & 0 & 1 & -1 & 0 & 0 & 0 \\ 1 & 0 & 1 & 0 & 0 & 0 & 0 & 0 & 0 & 0 & 0 \\ 0 & 0 & L_1 & 1 & -1 & 0 & kFL_1 & 0 & 0 & 0 & 0 \\ 0 & 0 & q_1L_1 - s_1 & q_1(1 - c_1) & 0 & 0 & kF(q_1L_1 - s_1) & 0 & 0 & kFs_1 & 0 \\ 0 & 0 & q_1L_1c_1 - s_1 & -q_1(1 - c_1) & 0 & 0 & kF(q_1L_1c_1 - s_1) & kFs_1 & 0 & 0 & 0 \\ 0 & 1 & 1 & 0 & 0 & 0 & 0 & 0 & 0 & 0 & 0 \\ 0 & 0 & -L_2 & 1 & 0 & 0 & 0 & 0 & kFL_2 & 0 & 0 \\ 0 & 0 & q_2L_2 - s_2 & -q_2(1 - c_2) & 0 & 0 & 0 & 0 & -kF(q_2L_2 - s_2) & 0 & kFs_2 \end{bmatrix} \quad (22)$$



$$\mathbf{x} \begin{bmatrix} R_a \\ R_d \\ R_{bc} \\ M_{bc} \\ M_a \\ \theta^a \\ \Psi_a \\ \varphi_a \\ \psi_d \\ \varphi_b \\ \varphi_c \end{bmatrix} = \begin{bmatrix} 0 \\ 0 \\ 0 \\ 0 \\ -\rho_1 L_1 \frac{\pi}{4} (D_{1e}^2 - D_{1i}^2) g \\ -\rho_1 L_1^2 \frac{\pi}{8} (D_{1e}^2 - D_{1i}^2) g - kFe_a \\ \frac{\rho_1 \pi (D_{1e}^2 - D_{1i}^2) g q_1}{4} \left( -\frac{L_1^2}{2} + \frac{[1 - c_1]}{q_1^2} \right) \\ -\frac{\rho_1 \pi (D_{1e}^2 - D_{1i}^2) g}{4} \left[ \frac{L_1}{2} (q_1 L_1 c_1 - 2s_1) + \frac{[1 - c_1]}{q_1} \right] \\ \rho_2 L_2 \frac{\pi}{4} D_2^2 g \\ -\rho_2 L_2^2 \frac{\pi}{8} D_2^2 g - kFe_d \\ \frac{\rho_2 \pi D_2^2 g q_2}{4} \left( \frac{L_2^2}{2} - \frac{(1 - c_2)}{q_2^2} \right) \end{bmatrix} \quad (23)$$

## 6 Case of hydraulic cylinders pin mounted at the beginning of the cylinder tube and fixed at the end of the piston rod

### 6.1 Critical buckling load

Use the following formula to calculate critical buckling load where  $q$ ,  $c$ ,  $s$  values are evaluated from  $F_{critical}$  in accordance with [Table 1](#) and [2.2](#):

$$\begin{aligned} & kF_{critical} L_3 s_1 (-L_1 q_2 c_2 - L_2 q_2 c_2 + s_2) + 3E_2 I_2 (L_1 + L_2) q_2 (q_1 c_1 c_2 - q_2 s_1 s_2) - 3E_2 I_2 q_1 c_1 s_2 - 3E_2 I_2 q_2 c_2 s_1 \\ & = 0 \end{aligned} \quad (24)$$

### 6.2 Linear system

Use the following set of formulae to calculate strain-load where  $q$ ,  $c$ ,  $s$  values are evaluated from  $F$  in accordance with [Table 1](#) and [2.2](#):

$$\begin{bmatrix} 0 & 0 & 0 & 0 & 0 & 0 & L_1 & -L_2 & 0 & 0 & 0 \\ 0 & 0 & 0 & 0 & 0 & 1 & -1 & -1 & 0 & 1 & -1 \\ 0 & 0 & 0 & \frac{L_3}{3E_2 I_2} & 0 & 1 & 0 & 0 & 0 & 0 & 0 \\ 1 & 0 & 1 & 0 & 0 & 0 & 0 & 0 & 0 & 0 & 0 \\ 0 & 0 & L_1 & 1 & 0 & 0 & kFL_1 & 0 & 0 & 0 & 0 \\ 0 & 0 & q_1 L_1 - s_1 & q_1 (1 - c_1) & 0 & 0 & kF(q_1 L_1 - s_1) & 0 & 0 & kFs_1 & 0 \\ 0 & 0 & 0 & 0 & 0 & 0 & 0 & 1 & 1 & 0 & 0 \\ 0 & 1 & 1 & 0 & 0 & 0 & 0 & 0 & 0 & 0 & 0 \\ 0 & 0 & -L_2 & 1 & 1 & 0 & 0 & kFL_2 & 0 & 0 & 0 \\ 0 & 0 & q_2 L_2 - s_2 & -q_2 (1 - c_2) & 0 & 0 & 0 & -kF(q_2 L_2 - s_2) & 0 & 0 & kFs_2 \\ 0 & 0 & q_2 L_2 c_2 - s_2 & q_2 (1 - c_2) & 0 & 0 & 0 & -kF(q_2 L_2 c_2 - s_2) & kFs_2 & 0 & 0 \end{bmatrix} \quad (25)$$

$$X \begin{bmatrix} R_a \\ R_d \\ R_{bc} \\ M_{bc} \\ M_d \\ \theta \\ \psi_a \\ \psi_d \\ \varphi_d \\ \varphi_b \\ \varphi_c \end{bmatrix} = \begin{bmatrix} 0 \\ 0 \\ 0 \\ -\rho_1 L_1 \frac{\pi}{4} (D_{1e}^2 - D_{1i}^2) g \\ -\rho_1 L_1^2 \frac{\pi}{8} (D_{1e}^2 - D_{1i}^2) g - kFe_a \\ \frac{\rho_1 \pi (D_{1e}^2 - D_{1i}^2) g q_1}{4} \left( -\frac{L_1^2}{2} + \frac{[1 - c_1]}{q_1^2} \right) \\ 0 \\ \rho_2 L_2 \frac{\pi}{4} D_2^2 g \\ -\rho_2 L_2^2 \frac{\pi}{8} D_2^2 g - kFe_d \\ \frac{\rho_2 \pi D_2^2 g q_2}{4} \left( \frac{L_2^2}{2} - \frac{(1 - c_2)}{q_2^2} \right) \\ \frac{\rho_2 \pi D_2^2 g}{4} \left( \frac{L_2}{2} (q_2 L_2 c_2 - 2s_2) + \frac{(1 - c_2)}{q_2} \right) \end{bmatrix} \tag{26}$$

## 7 Case of hydraulic cylinders fixed at both ends

### 7.1 Critical buckling load

Use the following formula to calculate critical buckling load where  $q, c, s$  values are evaluated from  $F_{critical}$  in accordance with [Table 1](#) and [2.2](#):

$$kF_{critical} L_3 [(L_1 + L_2) q_1 q_2 c_1 c_2 - q_1 c_1 s_2 - q_2 c_2 s_1] + 3E_2 I_2 (L_1 + L_2) q_1 q_2 (q_1 c_2 s_1 + q_2 c_1 s_2) - 3E_2 I_2 q_1^2 s_1 s_2 + 6E_2 I_2 q_1 q_2 (c_1 c_2 - 1) - 3E_2 I_2 q_2^2 s_1 s_2 = 0 \tag{27}$$

### 7.2 Linear system

Use the following set of formulae to calculate strain-load where  $q, c, s$  values are evaluated from  $F$  in accordance with [Table 1](#) and [2.2](#):

$$\begin{bmatrix} 0 & 0 & 0 & 0 & 0 & 0 & 0 & L_1 & 0 & -L_2 & 0 & 0 & 0 \\ 0 & 0 & 0 & 0 & 0 & 0 & 1 & -1 & 0 & -1 & 0 & 1 & -1 \\ 0 & 0 & 0 & \frac{L_3}{3E_2 I_2} & 0 & 0 & 1 & 0 & 0 & 0 & 0 & 0 & 0 \\ 0 & 0 & 0 & 0 & 0 & 0 & 0 & 1 & -1 & 0 & 0 & 0 & 0 \\ 1 & 0 & 1 & 0 & 0 & 0 & 0 & 0 & 0 & 0 & 0 & 0 & 0 \\ 0 & 0 & L_1 & 1 & -1 & 0 & 0 & kFL_1 & 0 & 0 & 0 & 0 & 0 \\ 0 & 0 & q_1 L_1 - s_1 & q_1 (1 - c_1) & 0 & 0 & 0 & kF(q_1 L_1 - s_1) & 0 & 0 & 0 & kFs_1 & 0 \\ 0 & 0 & q_1 L_1 c_1 - s_1 & -q_1 (1 - c_1) & 0 & 0 & 0 & kF(q_1 L_1 c_1 - s_1) & kFs_1 & 0 & 0 & 0 & 0 \\ 0 & 0 & 0 & 0 & 0 & 0 & 0 & 0 & 0 & 1 & 1 & 0 & 0 \\ 0 & 1 & 1 & 0 & 0 & 0 & 0 & 0 & 0 & 0 & 0 & 0 & 0 \\ 0 & 0 & -L_2 & 1 & 0 & 1 & 0 & 0 & 0 & kFL_2 & 0 & 0 & 0 \\ 0 & 0 & q_2 L_2 - s_2 & -q_2 (1 - c_2) & 0 & 0 & 0 & 0 & 0 & -kF(q_2 L_2 - s_2) & 0 & 0 & kFs_2 \\ 0 & 0 & q_2 L_2 c_2 - s_2 & q_2 (1 - c_2) & 0 & 0 & 0 & 0 & 0 & -kF(q_2 L_2 c_2 - s_2) & kFs_2 & 0 & 0 \end{bmatrix} \tag{28}$$

$$\mathbf{x} \begin{bmatrix} R_a \\ R_d \\ R_{bc} \\ M_{bc} \\ M_a \\ M_d \\ \theta \\ \psi_a \\ \phi_a \\ \psi_d \\ \phi_d \\ \phi_b \\ \phi_c \end{bmatrix} = \begin{bmatrix} 0 \\ 0 \\ 0 \\ 0 \\ -\rho_1 L_1 \frac{\pi}{4} (D_{1e}^2 - D_{1i}^2) g \\ -\rho_1 L_1^2 \frac{\pi}{8} (D_{1e}^2 - D_{1i}^2) g - kFe_a \\ \frac{\rho_1 \pi (D_{1e}^2 - D_{1i}^2) g q_1}{4} \left( -\frac{L_1^2}{2} + \frac{[1 - c_1]}{q_1^2} \right) \\ -\rho_1 \pi (D_{1e}^2 - D_{1i}^2) g \left( \frac{L_1}{2} (q_1 L_1 c_1 - 2s_1) + \frac{[1 - c_1]}{q_1} \right) \\ 0 \\ \rho_2 L_2 \frac{\pi}{4} D_2^2 g \\ -\rho_2 L_2^2 \frac{\pi}{8} D_2^2 g - kFe_d \\ \frac{\rho_2 \pi D_2^2 g q_2}{4} \left( \frac{L_2^2}{2} - \frac{(1 - c_2)}{q_2^2} \right) \\ \frac{\rho_2 \pi D_2^2 g}{4} \left( \frac{L_2}{2} (q_2 L_2 c_2 - 2s_2) + \frac{1}{q_2} (1 - c_2) \right) \end{bmatrix} \quad (29)$$

## 8 Case of hydraulic cylinders fixed at the beginning of the cylinder tube and free at the end of the piston rod

### 8.1 Critical buckling load

Use the following formula to calculate critical buckling load where  $q$ ,  $c$ ,  $s$  values are evaluated from  $F_{critical}$  in accordance with [Table 1](#) and [2.2](#):

$$kF_{critical} L_3 c_1 s_2 + 3E_2 I_2 q_1 s_1 s_2 - 3E_2 I_2 q_2 c_1 c_2 = 0 \quad (30)$$

8.2 Linear system

Use the following set of formulae to calculate strain-load where  $q, c, s$  values are evaluated from  $F$  in accordance with [Table 1](#) and [2.2](#):

$$\begin{bmatrix}
 0 & 0 & 0 & 0 & 0 & 0 & L_1 & 0 & -L_2 & 0 & 0 & 1 \\
 0 & 0 & 0 & 0 & 0 & 1 & -1 & 0 & -1 & 1 & -1 & 0 \\
 0 & 0 & 0 & \frac{L_3}{3E_2I_2} & 0 & 1 & 0 & 0 & 0 & 0 & 0 & 0 \\
 0 & 0 & 0 & 0 & 0 & 0 & 1 & -1 & 0 & 0 & 0 & 0 \\
 1 & 0 & 1 & 0 & 0 & 0 & 0 & 0 & 0 & 0 & 0 & 0 \\
 0 & 0 & L_1 & 1 & -1 & 0 & kFL_1 & 0 & 0 & 0 & 0 & 0 \\
 0 & 0 & q_1L_1 - s_1 & q_1(1 - c_1) & 0 & 0 & kF(q_1L_1 - s_1) & 0 & 0 & kFs_1 & 0 & 0 \\
 0 & 0 & q_1L_1c_1 - s_1 & -q_1(1 - c_1) & 0 & 0 & kF(q_1L_1c_1 - s_1) & kFs_1 & 0 & 0 & 0 & 0 \\
 0 & 1 & 1 & 0 & 0 & 0 & 0 & 0 & 0 & 0 & 0 & 0 \\
 0 & 0 & -L_2 & 0 & 0 & 0 & 0 & 0 & kFL_2 & 0 & 0 & 0 \\
 0 & 0 & q_2L_2 - s_2 & -q_2(1 - c_2) & 0 & 0 & 0 & 0 & -kF(q_2L_2 - s_2) & 0 & kFs_2 & 0 \\
 0 & 1 & 0 & 0 & 0 & 0 & 0 & 0 & 0 & 0 & 0 & C
 \end{bmatrix}$$

(31)

$$\begin{bmatrix}
 R_a \\
 R_d \\
 R_{bc} \\
 M_{bc} \\
 M_a \\
 \theta \\
 \psi_a \\
 \phi_a \\
 \psi_d \\
 \phi_b \\
 \phi_c \\
 \Delta
 \end{bmatrix}
 \times
 \begin{bmatrix}
 0 \\
 0 \\
 0 \\
 0 \\
 -\rho_1L_1 \frac{\pi}{4} (D_{1e}^2 - D_{1i}^2) g \\
 -\rho_1L_1^2 \frac{\pi}{8} (D_{1e}^2 - D_{1i}^2) g - kFe_a \\
 \frac{\rho_1\pi (D_{1e}^2 - D_{1i}^2) g q_1}{4} \left( -\frac{L_1^2}{2} + \frac{[1 - c_1]}{q_1^2} \right) \\
 -\rho_1\pi (D_{1e}^2 - D_{1i}^2) g \left( \frac{L_1}{2} (q_1L_1c_1 - 2s_1) + \frac{(1 - c_1)}{q_1} \right) \\
 \rho_2L_2 \frac{\pi}{4} D_2^2 g \\
 -\rho_2L_2^2 \frac{\pi}{8} D_2^2 g - kFe_d \\
 \frac{\rho_2\pi D_2^2 g q_2}{4} \left( \frac{L_2^2}{2} - \frac{(1 - c_2)}{q_2^2} \right) \\
 0
 \end{bmatrix}$$

(32)

If there is no support at the end of piston rod, then  $C = 0$ .

If this stiffness is set to a very large value (i.e.  $C = \infty$ ), then the results obtained using the group of formulae of the present case shall be similar to the one obtained for an hydraulic cylinder fixed at the beginning of the cylinder tube and pin mounted at the end of the piston rod.

## 9 Case of hydraulic cylinders fixed at both ends with free movement allowed at the end of the piston rod

### 9.1 Critical buckling load

Use the Formula 33 to calculate critical buckling load where  $q$ ,  $c$ ,  $s$  values are evaluated from  $F_{critical}$  in accordance with [Table 1](#) and [2.2](#):

$$kF_{critical}L_3 c_1c_2 + 3E_2I_2q_1c_2s_1 + 3E_2I_2q_2c_1s_2 = 0 \quad (33)$$

### 9.2 Linear system

Use the following set of formulae to calculate strain-load where  $q$ ,  $c$ ,  $s$  values are evaluated from  $F$  in accordance with [Table 1](#) and [2.2](#):

$$\begin{bmatrix}
 0 & 0 & 0 & 0 & 0 & 0 & 0 & L_1 & 0 & -L_2 & 0 & 0 & 0 & 1 \\
 0 & 0 & 0 & 0 & 0 & 0 & 1 & -1 & 0 & -1 & 0 & 1 & -1 & 0 \\
 0 & 0 & 0 & \frac{L_3}{3E_2I_2} & 0 & 0 & 1 & 0 & 0 & 0 & 0 & 0 & 0 & 0 \\
 0 & 0 & 0 & 0 & 0 & 0 & 0 & 1 & -1 & 0 & 0 & 0 & 0 & 0 \\
 1 & 0 & 1 & 0 & 0 & 0 & 0 & 0 & 0 & 0 & 0 & 0 & 0 & 0 \\
 0 & 0 & L_1 & 1 & -1 & 0 & 0 & kFL_1 & 0 & 0 & 0 & 0 & 0 & 0 \\
 0 & 0 & q_1L_1 - s_1 & q_1(1 - c_1) & 0 & 0 & 0 & kF(q_1L_1 - s_1) & 0 & 0 & 0 & kFs_1 & 0 & 0 \\
 0 & 0 & q_1L_1c_1 - s_1 & -q_1(1 - c_1) & 0 & 0 & 0 & kF(q_1L_1c_1 - s_1) & kFs_1 & 0 & 0 & 0 & 0 & 0 \\
 0 & 0 & 0 & 0 & 0 & 0 & 0 & 0 & 0 & 1 & 1 & 0 & 0 & 0 \\
 0 & 1 & 1 & 0 & 0 & 0 & 0 & 0 & 0 & 0 & 0 & 0 & 0 & 0 \\
 0 & 0 & -L_2 & 1 & 0 & 1 & 0 & 0 & 0 & kFL_2 & 0 & 0 & 0 & 0 \\
 0 & 0 & q_2L_2 - s_2 & -q_2(1 - c_2) & 0 & 0 & 0 & 0 & 0 & -kF(q_2L_2 - s_2) & 0 & 0 & kFs_2 & 0 \\
 0 & 0 & q_2L_2c_2 - s_2 & q_2(1 - c_2) & 0 & 0 & 0 & 0 & 0 & -kF(q_2L_2c_2 - s_2) & kFs_2 & 0 & 0 & 0 \\
 0 & 1 & 0 & 0 & 0 & 0 & 0 & 0 & 0 & 0 & 0 & 0 & 0 & C
 \end{bmatrix}$$

(34)

$$\begin{matrix}
 R_a \\
 R_d \\
 R_{bc} \\
 M_{bc} \\
 M_a \\
 M_d \\
 \theta \\
 \psi_a \\
 \varphi_a \\
 \psi_d \\
 \varphi_d \\
 \varphi_b \\
 \varphi_c \\
 \Delta
 \end{matrix}
 \times
 \begin{bmatrix}
 0 \\
 0 \\
 0 \\
 0 \\
 -\rho_1 L_1 \frac{\pi}{4} (D_{1e}^2 - D_{1i}^2) g \\
 -\rho_1 L_1^2 \frac{\pi}{8} (D_{1e}^2 - D_{1i}^2) g - kFe_a \\
 \frac{\rho_1 \pi (D_{1e}^2 - D_{1i}^2) g q_1}{4} \left( -\frac{L_1^2}{2} + \frac{[1 - c_1]}{q_1^2} \right) \\
 -\rho_1 \pi (D_{1e}^2 - D_{1i}^2) g \left( \frac{L_1}{2} (q_1 L_1 c_1 - 2s_1) + \frac{[1 - c_1]}{q_1} \right) \\
 0 \\
 \rho_2 L_2 \frac{\pi}{4} D_2^2 g \\
 -\rho_2 L_2^2 \frac{\pi}{8} D_2^2 g - kFe_d \\
 \frac{\rho_2 \pi D_2^2 g q_2}{4} \left( \frac{L_2^2}{2} - \frac{(1 - c_2)}{q_2^2} \right) \\
 \frac{\rho_2 \pi D_2^2 g}{4} \left( \frac{L_2}{2} (q_2 L_2 c_2 - 2s_2) + \frac{1}{q_2} (1 - c_2) \right) \\
 0
 \end{bmatrix}
 \tag{35}$$

If there is no support at the end of piston rod, then  $C = 0$ . If this stiffness is set to a very large value ( $C = \infty$ ), then the results obtained using the group of formulae of the present case shall be similar to the one obtained for a hydraulic cylinder fixed at both ends.

## Annex A (informative)

### Example of numerical results

#### A.1 Dimensions of the cylinder and material characteristics

The calculation is made for a cylinder with the characteristics presented in [Table A.1](#).

**Table A.1 — Dimensions of the calculated cylinder and material characteristics**

$D_{1i}$	$D_{1e}$	$D_2$	$L_1$	$L_2$	$L_3$	$e_a$	$e_d$	$k$
25 mm	32 mm	12 mm	Stroke_length + 36 mm	Stroke_length + 44 mm	12 mm	0 mm	0 mm	1
<b>Moduli of elasticity <math>E_1</math> and <math>E_2</math></b>			<b>Yield point <math>\sigma_e</math></b>	<b>Gravitational acceleraton, g</b>	<b>Mass per unit volume <math>\rho_1</math> and <math>\rho_2</math></b>			
220 000 N/mm <sup>2</sup> as stated here is for reference purposes only			360 N/mm <sup>2</sup>	9,81 m/s <sup>2</sup>	7,8E-06 kg/mm <sup>3</sup>			

#### A.2 Numeric results

Results for each type of fixation, single compressive stresses ( $F_{\max}/\text{piston\_rod\_section\_area}$ ) as a function of the slenderness ratio ( $\text{stroke\_length}/\text{piston\_rod\_gyration\_radius}$ ) are presented in [Figure A.1](#).

NOTE The slenderness definition as stated here is for reference purposes only.

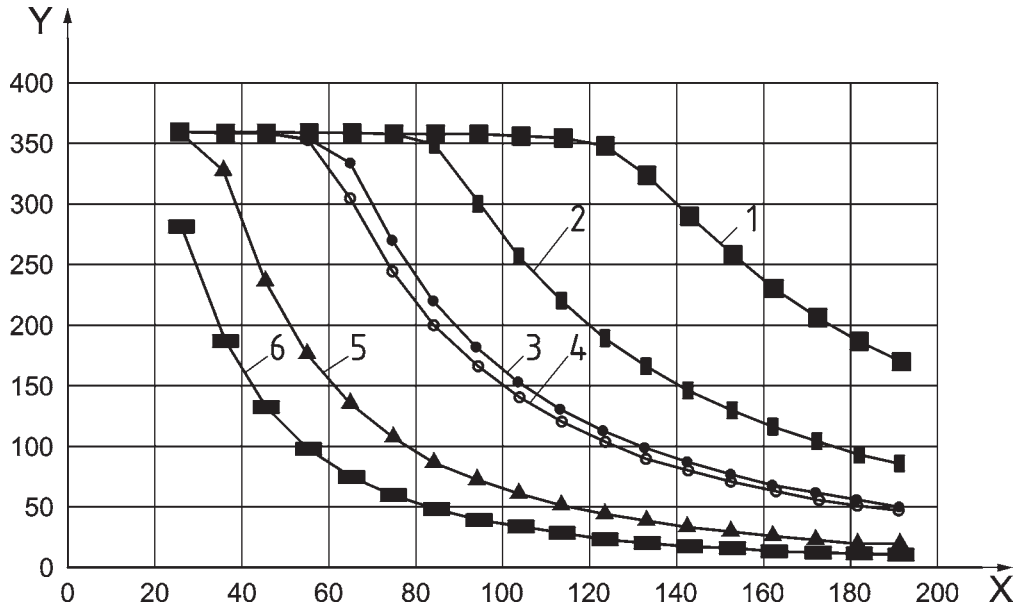

**Key**

- 1 two fixed ends (Table 2 and Clause 7)
- 2 fixed end: cylinder tube (Table 2 and Clause 5)
- 3 fixed end: piston rod (Table 2 and Clause 6)
- 4 piston rod: fixed end + free move (Table 2 and Clause 8)
- 5 pin mounted (Table 2 and Clause 4)
- 6 piston rod: free move (Table 2 and Clause 9)
- X slenderness ratio (= stroke\_length/piston\_rod\_gyration\_radius)
- Y allowable simple compressive stress (N/mm<sup>2</sup>)

**Figure A.1 — Results from ISO fluid power cylinder with a 25 mm tube and 12 mm piston diameters**



## Bibliography

- [1] NF PA/T3.6.37, *Hydraulic fluid power — Cylinders — Method for determining the buckling load*.
- [2] HOBLIT F. Critical buckling load for hydraulic actuating cylinders. *Production Engineering*, 1950 July

