Cutting tool data representation and exchange —

Part 5: Reference dictionary for assembly items

*Représentation et échange des données relatives aux outils
coupants —*

*Partie 5: Dictionnaire de référence de termes pour les éléments
d'assemblage*





COPYRIGHT PROTECTED DOCUMENT

© ISO 2014

All rights reserved. Unless otherwise specified, no part of this publication may be reproduced or utilized otherwise in any form or by any means, electronic or mechanical, including photocopying, or posting on the internet or an intranet, without prior written permission. Permission can be requested from either ISO at the address below or ISO's member body in the country of the requester.

ISO copyright office
Case postale 56 • CH-1211 Geneva 20
Tel. + 41 22 749 01 11
Fax + 41 22 749 09 47
E-mail copyright@iso.org
Web www.iso.org

Published in Switzerland

Contents

	Page
Foreword	iv
Introduction	vi
1 Scope	1
2 Normative references	2
3 Terms and definitions	2
4 Abbreviated terms	5
5 Representation of the ontology concepts as dictionary entries	5
5.1 General.....	5
5.2 assembly_item_type.....	5
6 Properties for assembly item types	12
Annex A (normative) Information object registration	14
Annex B (informative) Classification table	15
Annex C (informative) Class definitions	17
Annex D (informative) Assembly item property definitions	28
Annex E (informative) Illustrations of assembly item classes	38
Bibliography	51

Foreword

ISO (the International Organization for Standardization) is a worldwide federation of national standards bodies (ISO member bodies). The work of preparing International Standards is normally carried out through ISO technical committees. Each member body interested in a subject for which a technical committee has been established has the right to be represented on that committee. International organizations, governmental and non-governmental, in liaison with ISO, also take part in the work. ISO collaborates closely with the International Electrotechnical Commission (IEC) on all matters of electrotechnical standardization.

The procedures used to develop this document and those intended for its further maintenance are described in the ISO/IEC Directives, Part 1. In particular the different approval criteria needed for the different types of ISO documents should be noted. This document was drafted in accordance with the editorial rules of the ISO/IEC Directives, Part 2 (see www.iso.org/directives).

Attention is drawn to the possibility that some of the elements of this document may be the subject of patent rights. ISO shall not be held responsible for identifying any or all such patent rights. Details of any patent rights identified during the development of the document will be in the Introduction and/or on the ISO list of patent declarations received (see www.iso.org/patents).

Any trade name used in this document is information given for the convenience of users and does not constitute an endorsement.

For an explanation on the meaning of ISO specific terms and expressions related to conformity assessment, as well as information about ISO's adherence to the WTO principles in the Technical Barriers to Trade (TBT) see the following URL: Foreword - Supplementary information

The committee responsible for this document is ISO/TC 29, *Small tools*.

This second edition cancels and replaces the first edition (ISO/TS 13399-5:2007), which has been technically revised.

ISO 13399 consists of the following parts, under the general title *Cutting tool data representation and exchange*:

- *Part 1: Overview, fundamental principles and general information model*
- *Part 2: Reference dictionary for cutting items* [Technical Specification]
- *Part 3: Reference dictionary for tool items* [Technical Specification]
- *Part 4: Reference dictionary for adaptive items* [Technical Specification]
- *Part 5: Reference dictionary for accessory and auxiliary items* [Technical Specification]
- *Part 50 Reference dictionary for reference systems and common concepts* [Technical Specification]
- *Part 60: Reference dictionary for connection systems* [Technical Specification]
- *Part 100: Definitions, principles and methods for reference dictionaries* [Technical Specification]
- *Part 150: Usage guidelines* [Technical Specification]
- *Part 301: Concept for the design of 3D models based on properties according to ISO/TS 13399-3: Modelling of thread-cutting taps, thread-forming taps and thread-cutting dies* [Technical Specification]
- *Part 302: Concept for the design of 3D models based on properties according to ISO/TS 13399-3: Modelling of solid drills and countersinking tools* [Technical Specification]

The following parts are under preparation:

- *Part 51: Designation system for customer solution cutting tools*

- *Part 80: Concept for the design of 3D models based on properties according to ISO 13399: Overview and principles [Technical Specification]*
- *Part 201: Concept for the design of 3D models based on properties according to ISO/TS 13399-2: Modelling of regular inserts [Technical Specification]*
- *Part 202: Concept for the design of 3D models based on properties according to ISO/TS 13399-2: Modelling of irregular inserts [Technical Specification]*
- *Part 203: Concept for the design of 3D models based on properties according to ISO/TS 13399-2: Modelling of exchangeable inserts for drilling [Technical Specification]*
- *Part 204: Concept for the design of 3D models based on properties according to ISO/TS 13399-2: Modelling of inserts for reaming [Technical Specification]*
- *Part 303: Concept for the design of 3D models based on properties according to ISO/TS 13399-3: Modelling of end mills with non-indexable cutting edges [Technical Specification]*
- *Part 304: Concept for the design of 3D models based on properties according to ISO/TS 13399-3: Modelling of milling cutters with arbor hole and non-indexable cutting edges [Technical Specification]*
- *Part 307: Concept for the design of 3D models based on properties according to ISO/TS 13399-3: Modelling of end mills for indexable inserts [Technical Specification]*
- *Part 308: Concept for the design of 3D models based on properties according to ISO/TS 13399-3: Modelling of milling cutter with arbor hole for indexable inserts [Technical Specification]*
- *Part 309: Concept for the design of 3D models based on properties according to ISO/TS 13399-3: Tool holders for indexable inserts [Technical Specification]*
- *Part 311: Concept for the design of 3D models based on properties according to ISO/TS 13399-3: Modelling of solid reamers [Technical Specification]*
- *Part 312: Concept for the design of 3D models based on properties according to ISO/TS 13399-3: Modelling of reamers for indexable inserts [Technical Specification]*
- *Part 401: Concept for the design of 3D models based on properties according to ISO/TS 13399-4: Modelling of converting, extending and reducing adaptive items [Technical Specification]*
- *Part 405: Concept for the design of 3D models based on properties according to ISO/TS 13399-4: Modelling of collets [Technical Specification]*

Introduction

This part of ISO 13399 defines the terms, properties, and definitions for items that are used to create an assembly of a cutting tool with defined cutting edges. The purpose of this part of ISO 13399 is to provide a reference dictionary to support the use of the general information model in ISO 13399-1.

A cutting tool with defined cutting edges is used on a machine to remove material from a workpiece by a shearing action at the cutting edges of the tool. Cutting tool data that can be described by ISO 13399 (all parts) include, but are not limited to, everything between the workpiece and the machine tool. Information about inserts (e.g. regular and irregular shaped replaceable cutting items), solid tools (e.g. solid drill and solid endmill), assembled tools (e.g. boring bars, indexable drills, and indexable milling cutters), adaptors (e.g. milling arbor and drilling chuck), components (e.g. shims, screws, and clamps) and their relationships can be represented by ISO 13399 (all parts). Possible assemblies of the components of a cutting tool are illustrated in [Figure 1](#).

The objective of ISO 13399 (all parts) is to provide the means to represent the information that describes cutting tools in a computer-sensible form that is independent from any computer system. The representation will facilitate the processing and exchange of cutting tool data within and between different software systems and computer platforms and support the application of this data in manufacturing planning, cutting operations and the supply of tools. The nature of this description makes it suitable not only for neutral file exchange, but also as a basis for implementing and sharing product databases and for archiving. The methods used for these representations are those developed by ISO TC 184/SC 4 for the representation of product data by using standardised information models and reference dictionaries.

An information model is a formal specification of types, ideas, facts, and processes which together describe a portion of interests of the real world and which provides an explicit set of interpretation rules. Information is knowledge of ideas, facts, and/or, processes. Data are symbols or functions that represent information for processing purposes. Data are interpreted to extract information by using rules for how that should be done and a dictionary to define the terms that identify the data. Everyone in a communication process is expected to use the same information model, the same set of explicit rules, and the same dictionary in order to avoid misunderstanding. If an information model and its dictionary are written in a computer-sensible language, then there is the additional benefit that they can be computer processable.

An engineering information model is therefore a specification for data that establishes the meaning of that data in a particular engineering context. A model has to be developed by formal methods to ensure that it meets the needs of the situation that it represents. An engineering information model defines: the information objects that represent the concepts in an engineering application, the attributes of the objects, their relationships, and the constraints that add further meaning. An information model is an abstract concept that can be used repeatedly for any example of the real-world situation that it represents. An instance of the model is produced when it is populated with the data items and their values that are applicable to a particular example of that situation.

This part of ISO 13399 uses the following International Standards developed by ISO/TC 184/SC 4:

- the EXPRESS language defined in ISO 10303-11 for defining the information model in ISO 13399-1;
- the file format for data exchange derived from the model and defined in ISO 10303-21;
- the data dictionary defined in the ISO 13584 series.

The ISO 13399 series is intended for use by, among others, tool producers and vendors, manufacturers, and developers of manufacturing software. ISO 13399 provides a common structure for exchanging data about cutting tools with defined cutting edges. ISO 13399 is intended to provide for, or improve, several manufacturing activities, including

- the integration and sharing of data for cutting tools and assemblies between different stages for the manufacturing cycle and between different software applications,

- the direct import of data from cutting tool suppliers into a customer's database, and
- the management of cutting tool information from multiple sources and for multiple applications.

Different companies use different business models that determine their need for the communication of information about their products. For example, one cutting tool manufacturer could regrind its customers' tools while another could allow its customers to do the regrinding and provide the information to enable them to do so. Therefore, the two cutting tool manufacturers could have a different set of cutting tool properties to communicate using the information model and dictionaries provided in ISO 13399.

ISO 13399 defines only the information that could be communicated, but does not specify what information shall be communicated.

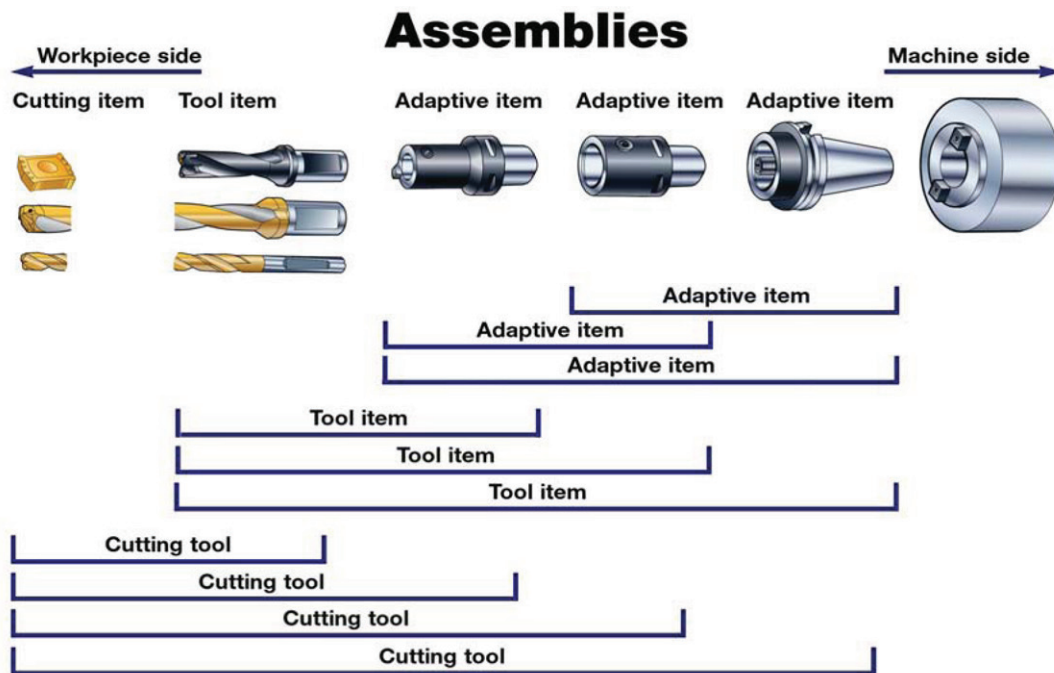

Figure 1 — Possible assemblies of the components of a cutting tool

Since the content of those dictionaries evolves according to industrial innovations and constant improvement of technology in cutting tools, a Maintenance Agency has been established for the purposes of

- correcting errors in the entries of existing classes and properties,
- adding new properties to existing classes,
- adding new classes and their properties,
- managing the status of those properties and classes, and
- migrating the dictionary to subsequent editions of ISO 13399 (all parts).

The secretariat of this Maintenance Agency has been assigned to:

Union de Normalisation de la Mécanique
F-92038 Paris La Défense CEDEX
France

by the ISO Technical Management Board.

ISO/TS 13399-5:2014(E)

The website of the Maintenance Agency is available at: http://www.unm.fr/main/core.php?pag_id=135

The reference dictionaries are available in the form of EXPRESS files on the website of the Maintenance Agency. These files are considered complementary to this part of ISO 13399; they can be freely downloaded and used for cutting tool data representation and exchange.

The following permission notice and disclaimer shall be included in all copies of this EXPRESS schema ("the Schema"), and derivations of the Schema:

© ISO 2014 – All rights reserved

Permission is hereby granted, free of charge in perpetuity, to any person obtaining a copy of the Schema, to use, copy, modify, merge and distribute free of charge, copies of the Schema for the purposes of developing, implementing, installing and using software based on the Schema, and to permit persons to whom the Schema is furnished to do so, subject to the following conditions:

THE SCHEMA IS PROVIDED "AS IS", WITHOUT WARRANTY OF ANY KIND, EXPRESSED OR IMPLIED, INCLUDING, BUT NOT LIMITED TO, THE WARRANTIES OF MERCHANTABILITY, FITNESS FOR A PARTICULAR PURPOSE AND NON-INFRINGEMENT. IN NO EVENT SHALL ISO, OR ANY OTHER LICENSOR THAT GRANTS THE RIGHT UNDER THE ABOVE PERMISSION TO USE THE SCHEMA, BE LIABLE FOR ANY CLAIM, DAMAGES OR OTHER LIABILITY, WHETHER IN AN ACTION OF CONTRACT, TORT OR OTHERWISE, ARISING FROM, OUT OF OR IN CONNECTION WITH THE SCHEMA OR THE USE OR OTHER DEALINGS IN THE SCHEMA.

In addition, any modified copy of the Schema shall include the following notice:

THIS SCHEMA HAS BEEN MODIFIED FROM THE SCHEMA DEFINED IN ISO 13399, AND SHOULD NOT BE INTERPRETED AS COMPLYING WITH THAT INTERNATIONAL STANDARD.

Cutting tool data representation and exchange —

Part 5: Reference dictionary for assembly items

1 Scope

This part of ISO 13399 specifies a reference dictionary for items used to assemble cutting tools, together with their descriptive properties and domains of values.

This part of ISO 13399 specifies a reference dictionary containing:

- definitions and identifications of the classes of assembly items, with an associated classification scheme;
- definitions and identifications of the data element types that represents the properties of assembly items;
- definitions and identifications of domains of values for describing the above-mentioned data element types.

Each class, property, or domain of values of this application domain constitutes an entry of the reference dictionary defined in this part of ISO 13399. It is associated with a computer-sensible and human-readable definition and with a computer-sensible identification. Identification of a dictionary entry allows unambiguous reference to it from any application that implements the information model defined in ISO 13399-1.

Definitions and identifications of dictionary entries are defined by means of standard data that consist of instances of the EXPRESS entity data types defined in the common dictionary schema, resulting from a joint effort between ISO/TC 184/SC 4 and IEC SC 3D, and in its extensions defined in ISO 13584-24 and ISO 13584-25.

The following are within the scope of this part of ISO 13399:

- standard data that represent the various classes of assembly items for cutting tools;
- standard data that represent the various properties of assembly items for cutting tools;
- standard data that represent domains of values used for properties of assembly items for cutting tools;
- one implementation method by which the standard data defined in this part of ISO 13399 can be exchanged.

NOTE 1 The implementation method by which the standard data defined in this part of ISO 13399 can be exchanged is specified in ISO 10303-21.

The following are outside the scope of this part of ISO 13399:

- specialized or expert knowledge on the design and use of cutting tools;
- rules to determine what information could be communicated;
- applications where these standard data can be stored or referenced;
- implementation methods other than the one defined in this part of ISO 13399 by which the standard data can be exchanged and referenced;

- information model for cutting tools;
- definitions of classes and properties for cutting items;
- definitions of classes and properties for tool items;
- definitions of classes and properties for adaptive items;
- definitions of classes and properties for reference systems and common features;
- definitions of classes and properties for connection interface features.

NOTE 2 The information model for cutting tools is defined in ISO 13399-1.

NOTE 3 The definitions of classes and properties for cutting items, tool items, adaptive items, reference systems and common features, and connection interface features are provided in ISO/TS 13399-2, ISO/TS 13399-3, ISO/TS 13399-4, ISO/TS 13399-50, and ISO/TS 13399-60, respectively.

2 Normative references

The following documents, in whole or in part, are normatively referenced in this document and are indispensable for its application. For dated references, only the edition cited applies. For undated references, the latest edition of the referenced document (including any amendments) applies.

ISO 1832:2012, *Indexable inserts for cutting tools — Designation*

ISO 3002-1, *Basic quantities in cutting and grinding — Part 1: Geometry of the active part of cutting tools — General terms, reference systems, tool and working angles, chip breakers*

ISO/TS 13399-100, *Cutting tool data representation and exchange — Part 100: Definitions, principles and methods for reference dictionaries*

3 Terms and definitions

For the purposes of this document, the terms and definitions given in ISO/TS 13399-100 (structure and contents of the dictionary) and the following apply.

NOTE The main collection of the terms and their definitions in the reference dictionary is provided in [Annexes B to D](#).

3.1 applicable property

property that is defined for some family of items and that shall apply to any member of this family

[SOURCE: ISO 13584-24:2003]

3.2 basic semantic unit

entity that provides an absolute and universally unique identification of a certain object of the application domain that is represented as a dictionary element

[SOURCE: ISO 13584-42:2010, 3.4]

3.3 chip

material removed from a workpiece by a cutting process

[SOURCE: ISO/TS 13399-2:2014, 3.3]

3.4 cutting tool

device or assembly of items for removing material from a workpiece through a shearing action at the defined cutting edge or edges of the device

[SOURCE: ISO 13399-1:2006, 3.1]

Note 1 to entry: A cutting tool could be an assembly of one or more adaptive items a tool item and several cutting items on a tool item. See [Figure 1](#).

3.5 data

representation of information in a formal manner suitable for communication, interpretation, or processing by human beings or computers

[SOURCE: ISO 10303-1:1994, 3.2.14]

3.6 data element type

unit of data for which the identification, description and value representation have been specified

[SOURCE: ISO 13584-42:2010, 3.13]

3.7 data exchange

storing, accessing, transferring, and archiving of data

[SOURCE: ISO 10303-1:1994, 3.2.15]

3.8 data type

domain of values

[SOURCE: ISO 10303-11:2004, 3.3.5]

3.9 dictionary

table consisting of a series of entries with one meaning corresponding to each entry in the dictionary and one dictionary entry identifying a single meaning

[SOURCE: ISO 13584-511:2006, 3.1.9]

Note 1 to entry: In the ISO 13399 series, a dictionary is a formal and computer-sensible representation of an ontology.

3.10 entity

class of information defined by its attributes that establishes a domain of values defined by common attributes and constraints

[SOURCE: ISO/TS 13399-2:2014, 3.10]

3.11 entity data type

representation of an entity

[SOURCE: ISO/TS 13399-2:2014, 3.11]

3.12

entity instance

named unit of data that represents a unit of information within the class defined by an entity.

[SOURCE: ISO/TS 13399-2:2014, 3.12]

Note 1 to entry: An entity instance is a member of the domain established by an entity data type.

3.13

family of products

set of products represented by the same characterization class

[SOURCE: ISO 13584-42:2010, 3.16]

3.14

implementation method

means for computers to exchange data

[SOURCE: ISO/TS 13399-2:2014, 3.14]

3.15

information

facts, concepts, or instructions

[SOURCE: ISO 10303-1:1994, 3.2.20]

3.16

information model

formal model of a bounded set of facts, concepts, or instructions to meet a specific requirement

[SOURCE: ISO 10303-1:1994, 3.2.21]

3.17

machine side

identification of a direction pointing towards the machine

3.18

machined surface

desired surface produced by the action of the cutting tool

[SOURCE: ISO 3002-1:1982, 3.1.2]

3.19

ontology

explicit and consensual specification of concepts of an application domain independent of any use of these concepts

[SOURCE: ISO 13584-511:2006, 3.1.20]

Note 1 to entry: In the ISO 13399 series, a dictionary is the formal and computer-sensible representation of an ontology.

3.20

property

defined parameter suitable for the description and differentiation of products

[SOURCE: ISO 13584-42:2010, 3.37]

3.21**visible property**

property that has a definition meaningful in the scope of a given characterization class, but that does not necessarily apply to the various products belonging to this class

[SOURCE: ISO 13584-42:2010, 3.46]

3.22**workpiece**

object on which a cutting action is performed

[SOURCE: ISO/TS 13399-2:2014, 3.24]

3.23**workpiece side**

identification of a direction pointing towards the workpiece

4 Abbreviated terms

For the purposes of this document, the following abbreviated terms apply.

BSU basic semantic unit

DET data element type

5 Representation of the ontology concepts as dictionary entries**5.1 General**

In the following subclauses, a concept in the ontology is identified by a name in lower-case characters. The name of a class that represents the concept in the dictionary is identified by bold, lower-case characters with multiple words linked by an underscore character.

EXAMPLE insert clamp is the name of a concept in the ontology. **insert_clamp** is the identifier of the class in the dictionary that represents the concept.

Each classified item in the following subclauses is associated with its definition from the dictionary.

Each entry in the dictionary, either a class or a property, is identified with a numerical code (BSU) that is generated at random when the dictionary is compiled. A BSU can be made unique by the addition of a code that is a reference to the supplier of the dictionary.

The structure of the classification is summarized in [Annex B](#). The complete definitions of the classes in this part of ISO 13399 are provided in [Annex C](#). The properties applicable to these classes are defined in [Annex D](#).

5.2 assembly_item_type

An **assembly_item_type** is a family of objects that enable the combination of items to form a cutting tool.

assembly item type has the following subclasses:

- **bearing;**
- **bush;**
- **centre_pin;**

- **coolant_deflector**;
- **driving_key**;
- **driving_ring**;
- **externally_threaded_fastener_component**;
- **insert_clamp**;
- **insert_clamping_system**;
- **insert_lever**;
- **insert_shim**;
- **insert_wedge**;
- **nest**;
- **nozzle**;
- **pin**;
- **retaining_ring**;
- **screw_thread_lining**;
- **sealing_ring**;
- **sleeve**;
- **spacer**;
- **spring**.

5.2.1 bearing

A **bearing** is an object to support a load and reduce the friction between two surfaces.

NOTE 1 This class is for general engineering use and is not specific to cutting tools.

NOTE 2 This class can become an **item_class_case_of** an entry in another dictionary conforming to ISO 13584.

5.2.2 bush

A **bush** is a hollow cylindrical object that fits in a hole.

NOTE 1 A **bush** can act as a **bearing**.

NOTE 2 This class is for general engineering use and is not specific to cutting tools.

NOTE 3 This class can become an item class case of an entry in another dictionary conforming to ISO 13584.

5.2.3 centre_pin

A **centre_pin** is an elongated rigid object secured to the tool item that locates and holds an insert and or a shim by its central hole.

5.2.4 coolant_deflector

A **coolant_deflector** is a device to change the direction of flow of a coolant supply.

5.2.5 driving_key

A **driving_key** is an object that fits in slots in components of an assembly to transmit torque from one component to the other and/or to locate the two components.

NOTE 1 This class is for general engineering use and is not specific to cutting tools.

NOTE 2 This class can become an **item_class_case_of** an entry in another dictionary conforming to ISO 13584.

5.2.6 driving_ring

A **driving_ring** is an annular-shaped object with integral keys or keyways that transmits torque from one component of an assembly to another.

NOTE 1 This class is for general engineering use and is not specific to cutting tools.

NOTE 2 This class can become an **item_class_case_of** an entry in another dictionary conforming to ISO 13584.

5.2.7 externally_threaded_fastener_component

An **externally_threaded_fastener_component** is a component class representing an externally threaded fastener.

NOTE **externally_threaded_fastener_component** is defined in ISO 13584-511.

externally_threaded_fastener_component has the following subclasses:

- **deflection_screw**;
- **differential_screw**;
- **eccentric_screw**;
- **insert_screw**;
- **lever_screw**;
- **shim_screw**.

5.2.7.1 deflection_screw

A **deflection_screw** is a screw with a conical portion of the shaft that can deflect to bear on the insert to hold it in place.

5.2.7.2 differential_screw

A **differential_screw** is an externally threaded fastener without a head with double-threaded shank with right-hand and left-hand threaded portions mainly used for fastening insert wedges.

5.2.7.3 eccentric_screw

An **eccentric_screw** is an externally threaded fastener with a round head that is not concentric with the shank.

5.2.7.4 insert_screw

An **insert_screw** is a screw with countersunk bearing surface used mainly for holding a cutting item on a tool item.

5.2.7.5 lever_screw

A **lever_screw** is an externally threaded fastener without a head and with a waist used for holding an insert lever in contact with the insert.

5.2.7.6 shim_screw

A **shim_screw** is an externally threaded fastener for holding a shim in a pocket with a central-threaded-through hole into which an insert screw can go to hold the insert.

5.2.8 insert_clamp

An **insert_clamp** is an object to apply a clamping force to an insert.

insert_clamp has the following subclasses:

- **cantilever_clamp**
- **floating_wedge_clamp**;
- **lever_top_clamp**;
- **wedge_clamp**.

5.2.8.1 cantilever_clamp

A **cantilever_clamp** is a rigid object with an extended arm to apply a downward force to an insert.

5.2.8.2 floating_wedge_clamp

A **floating_wedge_clamp** is an object to apply a downward force on an insert by movement of part of the object along the surface of a wedge.

5.2.8.3 lever_top_clamp

A **lever_top_clamp** is an object to apply a downward force on an insert by the action of a lever.

5.2.8.4 wedge_clamp

A **wedge_clamp** is an object with the shape of a wedge that applies a downward force to an insert and presses the insert against the centre pin.

5.2.9 insert_clamping_system

An **insert_clamping_system** is a family of assemblies of objects for holding a cutting item on a tool item.

insert_clamping_system has the following subclasses:

- **cantilever_clamping**;
- **deflection_screw_clamping**;
- **eccentric_screw_clamping**;
- **floating_wedge_clamping**;
- **insert_screw_clamping**;
- **integrated_clamping**;
- **lever_insert_clamping**;

- **lever_top_clamping**;
- **wedge_clamping**.

5.2.9.1 cantilever_clamping

A **cantilever_clamping** is an assembly for applying a holding force by a rigid cantilever arm.

5.2.9.2 deflection_screw_clamping

A **deflection_screw_clamping** is an assembly for applying a holding force by the bending of a symmetric screw caused by interference with the tool item.

5.2.9.3 eccentric_screw_clamping

An **eccentric_screw_clamping** is an assembly for applying a holding force by the eccentric rotation of a portion of a screw.

5.2.9.4 floating_wedge_clamping

A **floating_wedge_clamping** is an assembly for applying a holding force by the combined effect of a downward force and the lateral movement actuated by the surface of a wedge.

5.2.9.5 insert_screw_clamping

An **insert_screw_clamping** is an assembly for applying a holding force by the bearing surface of a symmetrical screw acting on the surface of a hole in the cutting item.

NOTE The axis of the threaded hole in the tool item is not coincident with the axis of the hole in the insert.

5.2.9.6 integrated_clamping

An **integrated_clamping** is an assembly for holding a cutting item in a tool item by the deflection of part of the tool item.

5.2.9.7 lever_insert_clamping

A **lever_insert_clamping** is an assembly for applying a holding force by the action of the end of a lever pressing on the inside of a hole in the cutting item.

5.2.9.8 lever_top_clamping

A **lever_top_clamping** is an assembly for applying a holding force on the top surface of a cutting item by the rotation of a lever about a pivot.

5.2.9.9 wedge_clamping

A **wedge_clamping** is an assembly for applying a holding force to an insert by the lateral movement of one or more wedge surfaces.

5.2.10 insert_lever

An **insert_lever** is an object that rotates about a pivot to apply a force to hold an insert onto a tool item.

5.2.11 insert_shim

An **insert_shim** is an object placed between a cutting item and a tool item.

NOTE The use of the shim is to position the cutting item and to protect it from damage.

5.2.12 insert_wedge

An **insert_wedge** is an object with at least two surfaces inclined to each other used for holding an insert.

5.2.13 nest

A **nest** is an assembly item that contains a seat or pocket that cradles and positions a replaceable cutting item but does not lock the replaceable cutting item by itself.

5.2.14 nozzle

A **nozzle** is an object with an aperture to direct the flow of a liquid or a gas.

5.2.15 pin

A **pin** is a thin rod-shaped object with parallel or tapered form.

NOTE 1 This class is for general engineering use and is not specific to cutting tools.

NOTE 2 This class can become an **item_class_case_of** an entry in another dictionary conforming to ISO 13584.

5.2.16 retaining_ring

A **retaining_ring** is an annular-shaped object that fits into a groove to prevent the separation of two components.

NOTE 1 This class is for general engineering use and is not specific to cutting tools.

NOTE 2 This class can become an **item_class_case_of** an entry in another dictionary conforming to ISO 13584.

5.2.17 screw_thread_lining

A **screw_thread_lining** is a helical coil that modifies an existing internal thread.

NOTE 1 This class is for general engineering use and is not specific to cutting tools.

NOTE 2 This class can become an **item_class_case_of** an entry in another dictionary conforming to ISO 13584.

5.2.18 sealing_ring

A **sealing_ring** is an annular-shaped object that prevents the passage of a fluid or gas.

NOTE 1 This class is for general engineering use and is not specific to cutting tools.

NOTE 2 This class can become an **item_class_case_of** an entry in another dictionary conforming to ISO 13584.

5.2.19 sleeve

A **sleeve** is a cylindrical object with an inner surface that can be cylindrical or tapered or profiled that fits over a shaft.

NOTE 1 The length of the cylinder is greater than the wall thickness and the critical dimensions are on the diameters of the object.

NOTE 2 This class is for general engineering use and is not specific to cutting tools.

NOTE 3 This class can become an **item_class_case_of** an entry in another dictionary conforming to ISO 13584.

5.2.20 spacer

A **spacer** is an object that separates two components at a defined distance.

NOTE 1 This class is for general engineering use and is not specific to cutting tools.

NOTE 2 This class can become an **item_class_case_of** an entry in another dictionary conforming to ISO 13584.

5.2.21 spring

A **spring** is an object that can store elastic energy by deforming under an applied load and can release the energy and return to its original shape or position when the load is removed.

NOTE 1 This class is for general engineering use and is not specific to cutting tools.

NOTE 2 This class can become an **item_class_case_of** an entry in another dictionary conforming to ISO 13584.

spring has the following subclasses:

- **cup_spring**;
- **flat_wire_compression_spring**;
- **gas_spring**;
- **helical_coil_spring**;
- **helical_disk_spring**;
- **leaf_spring**.

5.2.21.1 cup_spring

A **cup_spring** is an object where elastic energy is stored in the deflection of an annulus.

NOTE 1 This class is for general engineering use and is not specific to cutting tools.

NOTE 2 This class can become an **item_class_case_of** an entry in another dictionary conforming to ISO 13584.

5.2.21.2 flat_wire_compression_spring

A **flat_wire_compression_spring** is a cylindrical spring formed from waved strip.

NOTE 1 This class is for general engineering use and is not specific to cutting tools.

NOTE 2 This class can become an **item_class_case_of** an entry in another dictionary conforming to ISO 13584.

5.2.21.3 gas_spring

A **gas_spring** is an object where elastic energy is stored in a compressed gas.

NOTE 1 This class is for general engineering use and is not specific to cutting tools.

NOTE 2 This class can become an **item_class_case_of** an entry in another dictionary conforming to ISO 13584.

5.2.21.4 helical_coil_spring

An **helical_coil_spring** is an object where elastic energy is stored in a helix of either rectangular or circular cross-section wire.

NOTE 1 This class is for general engineering use and is not specific to cutting tools.

NOTE 2 This class can become an **item_class_case_of** an entry in another dictionary conforming to ISO 13584.

5.2.21.5 helical_disk_spring

An **helical_disk_spring** is a cylindrical spring formed from two intersecting coiled disks.

NOTE 1 This class is for general engineering use and is not specific to cutting tools.

NOTE 2 This class can become an **item_class_case_of** an entry in another dictionary conforming to ISO 13584.

5.2.21.6 leaf_spring

A **leaf_spring** is an object where elastic energy is stored in the deflection of a bent strip.

NOTE 1 This class is for general engineering use and is not specific to cutting tools.

NOTE 2 This class can become an **item_class_case_of** an entry in another dictionary conforming to ISO 13584.

6 Properties for assembly item types

The properties of assembly item types are defined in [Annex D](#), where the association of a property with a class is specified. In the compilation of the dictionary, all properties are visible properties at the root class of the dictionary and are made applicable properties at the class level where they apply. The names of properties that can be applicable for assembly item types, with their identification codes (BSU), are shown in [Table 1](#). The order of names in the table should be read in rows from left to right.

NOTE The BSU can be made unique by the addition of the code for the supplier of the dictionary as a prefix to the identification code.

EXAMPLE The unique BSU for **pin end shape** would be: 0112/1///13399__2-71EC5E54A9B4F for version two of the dictionary.

Table 1 — Properties for assembly item types

Property name	Identification code (BSU)
adjustability	71EBBA9E78025
connection bore diameter maximum	71EBDBF4D0F49
connection bore diameter minimum	71EBDBF49F96C
connection code machine side	71D102AE3B252
connection code workpiece side	71D102AE8A5A9
diameter inner	71FAD51836C93
diameter outer	71FAD51880679
hand	71CF29872F0AB
height	71EC61D8F250D
insert seat size code	71CEAEBF2A69F
insert shape code	71CE7A9F0C79F
length	71EC61D6B66E6
pin end shape	71EC5E54A9B4F
pin fixing method	71FAD53253A1B
section style	71EC65A21E9D4
shaft diameter	71FAD52B8F653
shaft length	71FAD52C3FC9E
spring coefficient	71FAE06BBB597
taper angle	71EAC4A2B6544
taper gradient	71CEAEC02FEBD

Annex A **(normative)**

Information object registration

A.1 Document identification

In order to provide for unambiguous identification of an information object in an open system, the object identifier:

{iso technical specification 13399 part (5) version (2)}

is assigned to this part of ISO 13399.

The meaning of this value is defined in ISO/IEC 8824-1 and is described in ISO 13584-1.

A.2 Dictionary identification

The dictionary defined in this part of ISO 13399 is assigned the object identifier:

{iso technical specification 13399 part (5) version (2) object (2) assembly items (2)}

Annex B (informative)

Classification table

[Table B.1](#) shows the classification structure of the generic families in the complete dictionary with an expanded structure for the class of **assembly item type**. The purpose of the table is to show the relationships between the classes related to assembly item types and the other classes in ISO 13399 (all parts).

NOTE [Annex C](#) contains the full definition of all the classes that are subclasses of **assembly item type**.

Table B.1 — Classification table

Classification structure	Parent	BSU
cutting tool library	Root	71CE7A72B6DA7
adaptive item type	71CE7A72B6DA7	71EAD37F18F34
adjustment	71CE7A72B6DA7	71ED884159C90
assembly item type	71CE7A72B6DA7	71CE7A795C05C
bearing	71CE7A795C05C	71EC56BC68ED7
bush	71CE7A795C05C	71EC61E259139
centre pin	71CE7A795C05C	71FAD519268DE
coolant deflector	71CE7A795C05C	71ED80E62E75A
driving key	71CE7A795C05C	71EC56B51596E
driving ring	71CE7A795C05C	71EC56B58A355
externally threaded fastener component	71CE7A795C05C	71FA4B678C52A
deflection screw	71FA4B678C52A	71FC030E04050
differential screw	71FA4B678C52A	71FAE07C0A4A6
eccentric screw	71FA4B678C52A	71FAE07B90EEC
insert screw	71FA4B678C52A	71ED798F61BC2
lever screw	71FA4B678C52A	71FAE07BCAC80
shim screw	71FA4B678C52A	71FC81BA3ECE9
insert clamp	71CE7A795C05C	71ED80DF6F976
cantilever clamp	71ED80DF6F976	71FAD54E002D6
floating wedge clamp	71ED80DF6F976	71FAD54E5A5BF
lever top clamp	71ED80DF6F976	71FAD54E2FE26
wedge clamp	71ED80DF6F976	71FAD54EABA17
insert clamping system	71CE7A795C05C	71EC56BAC1A7E
cantilever clamping	71EC56BAC1A7E	71EC56D6D0499
deflection screw clamping	71EC56BAC1A7E	71EC56D97E8B0
eccentric screw clamping	71EC56BAC1A7E	71EC56D908782
floating wedge clamping	71EC56BAC1A7E	71EC56D7601AD
insert screw clamping	71EC56BAC1A7E	71EC56D8A655A
integrated clamping	71EC56BAC1A7E	71FAD547E744B

Table B.1 (continued)

Classification structure	Parent	BSU
lever insert clamping	71EC56BAC1A7E	71EC6588A8C9E
lever top clamping	71EC56BAC1A7E	71EC56D71B815
wedge clamping	71EC56BAC1A7E	71EC56D828198
insert lever	71CE7A795C05C	71ED80DFB6371
insert shim	71CE7A795C05C	71EC56BD5DCD8
insert wedge	71CE7A795C05C	71EC56B608ADC
nest	71CE7A795C05C	71EAD70F1B95A
nozzle	71CE7A795C05C	71ED80E1EC9F6
pin	71CE7A795C05C	71EC56B5B6465
retaining ring	71CE7A795C05C	71EC5A6E9F6F0
screw thread lining	71CE7A795C05C	71EC56BA2E64E
sealing ring	71CE7A795C05C	71EC5A6E85D77
sleeve	71CE7A795C05C	71EC56BBA9A2E
spacer	71CE7A795C05C	71EC5A6CFD68B
spring	71CE7A795C05C	71EC56BA16ACB
cup spring	71EC56BA16ACB	71EC56E165BC7
flat wire compression spring	71EC56BA16ACB	71EC56E106606
gas spring	71EC56BA16ACB	71EC56E1C4C7D
helical coil spring	71EC56BA16ACB	71EC56E04199D
helical disk spring	71EC56BA16ACB	71EC56E0D4D19
leaf spring	71EC56BA16ACB	71EC56E223664
bolt hole circle	71CE7A72B6DA7	71E02520881F1
connection interface feature	71CE7A72B6DA7	71DF8C37D9115
coolant supply	71CE7A72B6DA7	71DF8C3C065EB
cutting item feature	71CE7A72B6DA7	71DD6C82F72DA
cutting item type	71CE7A72B6DA7	71D1AA6C8FC75
cutting operation	71CE7A72B6DA7	71DFF83D21D50
cutting tool	71CE7A72B6DA7	71CE7A7A5038B
flange	71CE7A72B6DA7	71EC5A767182E
keyway	71CE7A72B6DA7	71DF5C026BCE7
locking mechanism	71CE7A72B6DA7	71EBAB85BB5FA
reference system	71CE7A72B6DA7	71CF2968F7A9E
runout axial	71CE7A72B6DA7	71EDD2B84143C
runout radial	71CE7A72B6DA7	71EDD2B858274
tool item feature	71CE7A72B6DA7	71DD70376771D
tool item type	71CE7A72B6DA7	71E01A004C775
tool thread external	71CE7A72B6DA7	71FC1D22BF4CD
tool thread internal	71CE7A72B6DA7	71FC1D25097D7

Annex C (informative)

Class definitions

The content of this annex is limited to the classes of assembly items.

The layout of the information for each class in this Annex is:

BSU code – version number	Revision number
Preferred name	Short name
Definition	
NOTE	
REMARKS	
Properties:	
Subclasses:	
Illustration reference: < BSU of reference diagram > Figure < Annex.illustration number >	

71CE7A795C05C-001	001
assembly item type	astp
family of objects that enable the combination of items to form a cutting tool	

Subclasses:

71EC56BC68ED7-001	bearing
71EC61E259139-001	bush
71FAD519268DE-001	centre pin
71ED80E62E75A-001	coolant deflector
71EC56B51596E-001	driving key
71EC56B58A355-001	driving ring
71FA4B678C52A-002	externally threaded fastener component
71ED80DF6F976-001	insert clamp
71EC56BAC1A7E-001	insert clamping system
71ED80DFB6371-001	insert lever
71EC56BD5DCD8-001	insert shim
71EC56B608ADC-001	insert wedge
71EAD70F1B95A-001	nest

ISO/TS 13399-5:2014(E)

71ED80E1EC9F6-001	nozzle
71EC56B5B6465-001	pin
71EC5A6E9F6F0-001	retaining ring
71EC56BA2E64E-001	screw thread lining
71EC5A6E85D77-001	sealing ring
71EC56BBA9A2E-001	sleeve
71EC5A6CFD68B-001	spacer
71EC56BA16ACB-001	spring

71EC56BC68ED7-001 **001**

bearing **bearing**

object to support a load and reduce the friction between two surfaces

NOTE 1 This class is for general engineering use and is not specific to cutting tools.

NOTE 2 This class can become an **item_class_case_of** an entry in another dictionary conforming to ISO 13584.

71EC61E259139-001 **001**

bush **bush**

hollow cylindrical object that fits in a hole

NOTE 1 A bush can act as a bearing.

NOTE 2 This class is for general engineering use and is not specific to cutting tools.

NOTE 3 This class can become an **item_class_case_of** an entry in another dictionary conforming to ISO 13584.

71FAD519268DE-001 **001**

centre pin **ctpn**

elongated rigid object secured to the tool item that locates and holds an insert and or a shim by its central hole

Properties:

71EC61D6B66E6-001	length
71EC5E54A9B4F-001	pin end shape
71FAD53253A1B-001	pin fixing method
71FAD52B8F653-001	shaft diameter
71FAD52C3FC9E-001	shaft length

Illustration reference: 71FC81BB78797-1 [Figure E.1](#)

71ED80E62E75A-001 **001**

coolant deflector **cndf**

device to change the direction of flow of a coolant supply

71EC56B51596E-001 **001**

driving key **key**

object that fits in slots in components of an assembly to transmit torque from one component to the other and or to locate the two components

NOTE 1 This class is for general engineering use and is not specific to cutting tools.

NOTE 2 This class can become an item class case of an entry in another dictionary conforming to ISO 13584.

71EC56B58A355-001 **002**

driving ring **drvrn**

annular-shaped object with integral keys or keyways that transmits torque from one component of an assembly to another

NOTE 1 This class is for general engineering use and is not specific to cutting tools.

NOTE 2 This class can become an item class case of an entry in another dictionary conforming to ISO 13584.

71FA4B678C52A-002 **001**

externally threaded fastener component **etfc**

component class representing an externally threaded fastener

Subclasses:

71FC030E04050-001 deflection screw
 71FAE07C0A4A6-001 differential screw
 71FAE07B90EEC-001 eccentric screw
 71ED798F61BC2-001 insert screw
 71FAE07BCAC80-001 lever screw
 71FC81BA3ECE9-001 shim screw

71FC030E04050-002 **002**

deflection screw **dflscw**

screw with a conical portion of the shaft that can deflect to bear on the insert to hold it in place

Properties:

71E03063ABD6E drive size

71FAE07C0A4A6-002 **002**

differential screw **dfscw**

ISO/TS 13399-5:2014(E)

externally threaded fastener without a head with double-threaded shank with right-hand and left-hand threaded portions mainly used for fastening insert wedges

Properties:

71E03063ABD6E drive size

71FAE07B90EEC-002 002

eccentric screw ecscw

externally threaded fastener with a round head that is not concentric with the shank

Properties:

71E03063ABD6E drive size

71ED798F61BC2-002 002

insert screw inscw

screw with countersunk bearing surface used mainly for holding a cutting item on a tool item

Properties:

71E03063ABD6E drive size

71FAE07BCAC80-002 002

lever screw lvscw

externally threaded fastener without a head and with a waist used for holding an insert lever in contact with the insert

Properties:

71E03063ABD6E drive size

71FC81BA3ECE9-002 002

shim screw shmscw

externally threaded fastener for holding a shim in a pocket with a central-threaded-through hole into which an insert screw can go to hold the insert

Properties:

71E03063ABD6E drive size

71ED80DF6F976-002 002

insert clamp insclp

object to apply a clamping force to an insert

Subclasses:

71FAD54E002D6-001	cantilever clamp
71FAD54E5A5BF-001	floating wedge clamp
71FAD54E2FE26-001	lever top clamp
71FAD54EABA17-001	wedge clamp

Properties:

71E03063ABD6E	drive size
---------------	------------

71FAD54E002D6-001 001

cantilever clamp cantclp

rigid object with an extended arm to apply a downward force to an insert

71FAD54E5A5BF-001 001

floating wedge clamp flwdclp

object to apply a downward force on an insert by movement of part of the object along the surface of a wedge

71FAD54E2FE26-001 001

lever top clamp lvtclp

object to apply a downward force on an insert by the action of a lever

Properties:

71CF29872F0AB-001	hand
-------------------	------

71FAD54EABA17-001 001

wedge clamp wdgclp

object with the shape of a wedge that applies a downward force to an insert and presses the insert against the centre pin

71EC56BAC1A7E-001 002

insert clamping system insclps

family of assemblies of objects for holding a cutting item on a tool item

Subclasses:

71EC56D6D0499-001	cantilever clamping
71EC56D97E8B0-001	deflection screw clamping
71EC56D908782-001	eccentric screw clamping

ISO/TS 13399-5:2014(E)

71EC56D7601AD-001	floating wedge clamping
71EC56D8A655A-001	insert screw clamping
71FAD547E744B-001	integrated clamping
71EC6588A8C9E-001	lever insert clamping
71EC56D71B815-001	lever top clamping
71EC56D828198-001	wedge clamping

71EC56D6D0499-001 **001**
cantilever clamping **ctlclp**
assembly for applying a holding force by a rigid cantilever arm

71EC56D97E8B0-001 **001**
deflection screw clamping **dfscp**
assembly for applying a holding force by the bending of a symmetric screw caused by interference with the tool item

71EC56D908782-001 **001**
eccentric screw clamping **ecscp**
assembly for applying a holding force by the eccentric rotation of a portion of a screw

71EC56D7601AD-001 **001**
floating wedge clamping **fwgcp**
assembly for applying a holding force by the combined effect of a downward force and the lateral movement actuated by the surface of a wedge

71EC56D8A655A-001 **001**
insert screw clamping **scwcp**
assembly for applying a holding force by the bearing surface of a symmetric screw acting on the surface of a hole in the cutting item

NOTE The axis of the threaded hole in the tool item is not coincident with the axis of the hole in the insert.

71FAD547E744B-001 **001**
integrated clamping **intclp**
assembly for holding a cutting item in a tool item by the deflection of part of the tool item

71EC6588A8C9E-001 **001**

lever insert clamping **lvicp**

assembly for applying a holding force by the action of the end of a lever pressing on the inside of a hole in the cutting item

71EC56D71B815-001 **001**

lever top clamping **lvtcp**

assembly for applying a holding force on the top surface of a cutting item by the rotation of a lever about a pivot

71EC56D828198-001 **001**

wedge clamping **wgcp**

assembly for applying a holding force by the lateral movement of one or more wedge surfaces

71ED80DFB6371-001 **001**

insert lever **lvr**

object that rotates about a pivot to apply a force to hold an insert onto a tool item

71EC56BD5DCD8-001 **001**

insert shim **shim**

object placed between a cutting item and a tool item

NOTE The use of the shim is to position the cutting item and to protect it from damage.

71EC56B608ADC-001 **001**

insert wedge **wedge**

object with at least two surfaces inclined to each other used for holding an insert

Properties:

71CF29872F0AB-001 hand

71EAD70F1B95A-001 **001**

nest **nest**

assembly item that contains a seat or pocket that cradles and positions a replaceable cutting item but does not lock the replaceable cutting item by itself

Properties:

71CEAEBF2A69F-001 insert seat size code

ISO/TS 13399-5:2014(E)

71CE7A9F0C79F-001 insert shape code

71ED80E1EC9F6-001 001

nozzle nzl

object with an aperture to direct the flow of a liquid or a gas

Properties:

71EBBA9E78025-002 adjustability

71FAD51836C93-001 diameter inner

71EC56B5B6465-001 001

pin pin

thin rod-shaped object with parallel or tapered form

NOTE 1 This class is for general engineering use and is not specific to cutting tools.

NOTE 2 This class can become an item class case of an entry in another dictionary conforming to ISO 13584.

71EC5A6E9F6F0-001 001

retaining ring rtrg

annular-shaped object that fits into a groove to prevent the separation of two components

NOTE 1 This class is for general engineering use and is not specific to cutting tools.

NOTE 2 This class can become an item class case of an entry in another dictionary conforming to ISO 13584.

71EC56BA2E64E-001 001

screw thread lining thread lining

helical coil that modifies an existing internal thread

NOTE 1 This class is for general engineering use and is not specific to cutting tools.

NOTE 2 This class can become an item class case of an entry in another dictionary conforming to ISO 13584.

71EC5A6E85D77-001 001

sealing ring slrg

annular-shaped object that prevents the passage of a fluid or gas

NOTE 1 This class is for general engineering use and is not specific to cutting tools.

NOTE 2 This class can become an **item_class_case_of** an entry in another dictionary conforming to ISO 13584.

71EC56BBA9A2E-001 001

sleeve sleeve

cylindrical object with an inner surface that can be cylindrical or tapered or profiled that fits over a shaft

NOTE 1 The length of the cylinder is greater than the wall thickness and the critical dimensions are on the diameters of the object.

NOTE 2 This class is for general engineering use and is not specific to cutting tools.

NOTE 3 This class can become an item class case of an entry in another dictionary conforming to ISO 13584.

71EC5A6CFD68B-001 001

spacer sPCR

object that separates two components at a defined distance

NOTE 1 This class is for general engineering use and is not specific to cutting tools.

NOTE 2 This class can become an item class case of an entry in another dictionary conforming to ISO 13584.

71EC56BA16ACB-001 001

spring spring

object that can store elastic energy by deforming under an applied load and can release the energy and return to its original shape or position when the load is removed

NOTE 1 This class is for general engineering use and is not specific to cutting tools.

NOTE 2 This class can become an item class case of an entry in another dictionary conforming to ISO 13584.

Subclasses:

- 71EC56E165BC7-001 cup spring
- 71EC56E106606-001 flat wire compression spring
- 71EC56E1C4C7D-001 gas spring
- 71EC56E04199D-001 helical coil spring
- 71EC56E0D4D19-001 helical disk spring
- 71EC56E223664-001 leaf spring

Properties:

- 71FAE06BBB597-001 spring coefficient

71EC56E165BC7-001 001

cup spring spCP

object where elastic energy is stored in the deflection of an annulus

NOTE 1 This class is for general engineering use and is not specific to cutting tools.

NOTE 2 This class can become an **item_class_case_of** an entry in another dictionary conforming to ISO 13584.

71EC56E106606-001 001

flat wire compression spring spfWC

cylindrical spring formed from waved strip

NOTE 1 This class is for general engineering use and is not specific to cutting tools.

NOTE 2 This class can become an **item_class_case_of** an entry in another dictionary conforming to ISO 13584.

Properties:

ISO/TS 13399-5:2014(E)

71FAD51836C93-001	diameter inner
71FAD51880679-001	diameter outer
71EC61D6B66E6-001	length

71EC56E1C4C7D-001 001

gas spring spgs

object where elastic energy is stored in a compressed gas

NOTE 1 This class is for general engineering use and is not specific to cutting tools.

NOTE 2 This class can become an **item_class_case_of** an entry in another dictionary conforming to ISO 13584.

71EC56E04199D-001 001

helical coil spring sphc

object where elastic energy is stored in a helix of either rectangular or circular cross-section wire

NOTE 1 This class is for general engineering use and is not specific to cutting tools.

NOTE 2 This class can become an **item_class_case_of** an entry in another dictionary conforming to ISO 13584.

Properties:

71FAD51836C93-001	diameter inner
71FAD51880679-001	diameter outer
71EC65A21E9D4-002	section style

71EC56E0D4D19-001 001

helical disk spring sphd

cylindrical spring formed from two intersecting coiled disks

NOTE 1 This class is for general engineering use and is not specific to cutting tools.

NOTE 2 This class can become an **item_class_case_of** an entry in another dictionary conforming to ISO 13584.

Properties:

71FAD51836C93-001	diameter inner
71FAD51880679-001	diameter outer

71EC56E223664-001 001

leaf spring splf

object where elastic energy is stored in the deflection of a bent strip

NOTE 1 This class is for general engineering use and is not specific to cutting tools.

NOTE 2 This class can become an **item_class_case_of** an entry in another dictionary conforming to ISO 13584.

Properties:

71EC61D8F250D-001 height

71EC61D6B66E6-001 length

Annex D (informative)

Assembly item property definitions

The layout of the entries in this annex is as follows:

NOTE 1 An entry might not contain all the information specified.

NOTE 2 The value formats of properties are specified in ISO 13399-100.

BSU-version number	Revision number	Value format
data type group	data type	unit identifier
preferred name	short name	SYMBOL

definition

source of definition

BSU of condition property = name of condition property

Non-quantifiable code = meaning of code

Source of code definition

NOTE

REMARKS

BSU of reference diagram

Illustration reference: <Annex><Illustration number>

Visible class:

Applicable classes:

Allowed values:

71EBBA9E78025-002 **002** **NR1 S.4**

NON QUANTITATIVE INTERGER_TYPE

Adjustability **adjby** ADJBY

indicator for if an item is adjustable

NOTE A value of 0 means that the item is not adjustable. A value of 1 means that the item is adjustable.

Visible class:

71CE7A72B6DA7-002 cutting tool library

Applicable classes:

71E01A04C377D-002 broach

71D1066F279AD-002 cartridge
 71ED80E1EC9F6-001 nozzle
 71E01A04A8AEC-002 ream

Allowed values:

0 = not adjustable
 1 = radial adjustable
 2 = axial adjustable
 3 = radial and axial adjustable

71EBDBF4D0F49-001 001 NR2 S.3.3

LEVEL_TYPE mm

connection bore diameter maximum dcbx DCBX

greatest internal diameter of an adaptive item that can participate in a connection

71EBDBF130AE6-1 = side

REMARKS The term is connection bore diameter maximum.

Illustration reference: 71FC0A6DE2884-1

Visible class:

71CE7A72B6DA7-002 cutting tool library

Applicable classes:

726F59BDC3B08-002 collet

71EAD3871D313-002 converter

71EBDBF49F96C-001 001 NR2 S.3.3

LEVEL_TYPE mm

connection bore diameter minimum dcbn DCBN

least internal diameter of an adaptive item that can participate in a connection

71EBDBF130AE6-1 = side

Illustration reference: 71FC0A6DFD0F8-1

Visible class:

71CE7A72B6DA7-002 cutting tool library

Applicable classes:

726F59BDC3B08-002 collet

71EAD3871D313-002 converter

71D102AE3B252-001 **001** **X14**

STRING_TYPE

connection code machine side **ccms** **CCMS**

identifier for the capability to connect a component of a cutting tool to another component on the machine side

NOTE 1 The value of a code is constructed from the combination of the item feature class short name and the values of connection size code, variant, connection units basis, coolant supply property, and form type.

NOTE 2 Two items can be connected together if they have the same value of the code.

NOTE 3 The connection code is not applicable to assembly items in general but is applicable to the collet class.

REMARKS An example for a cylindrical shank conforming to ISO 3338-2 with shank diameter of 25 mm and with internal coolant would be: ZYL025010M1EXT.

Illustration reference: 71FC0E0CEB7FE-1

Visible class:

71CE7A72B6DA7-002 **cutting tool library**

Applicable classes:

71EAD37F18F34-002 adaptive item type

726F59BDC3B08-002 collet

71DF8C37D9115-002 connection interface feature

71E01A004C775-002 tool item type

71D102AE8A5A9-001 **001** **X14**

STRING_TYPE

connection code workpiece side **ccws** **CCWS**

identifier for the capability to connect a component to another component of a cutting tool on the workpiece side

NOTE 1 The value of a code is constructed from the combination of the item feature class short name and the values of: connection size code, variant, connection unit basis, coolant supply property, and form type.

NOTE 2 Two items can be connected together if they have the same value of the code.

NOTE 3 The connection code is not applicable to cutting items or assembly items in general but is applicable to the collet class.

REMARKS An example of a collet chuck adaptor fitting a collet conforming to DIN 6499 with a size of 16 mm without coolant would be: SZD016002M0INT.

Illustration reference: 71FC0E0CF0C10-1

Visible class:

71CE7A72B6DA7-002 **cutting tool library**

Applicable classes:

71EAD37F18F34-002	adaptive item type
71E01A04C377D-002	broach
726F59BDC3B08-002	collet
71DF8C37D9115-002	connection interface feature
71E01A00BD93C-002	drill
71E01A008D13F-002	mill
71E0251F304E1-002	rotating borer
71E01A05104CF-002	turn

71FAD51836C93-001 001 NR2 S.3.3

REAL_MEASURE_TYPE mm

diameter inner dinn DINN

distance between parallel tangents to the inner surface of a cylindrical object

Visible class:

71CE7A72B6DA7-002 cutting tool library

Applicable classes:

71EC56E106606-001	flat wire compression spring
71EC56E04199D-001	helical coil spring
71EC56E0D4D19-001	helical disk spring
71ED80E1EC9F6-001	nozzle

71FAD51880679-001 001 NR2 S.3.3

REAL_MEASURE_TYPE mm

diameter outer diout DIOUT

distance between parallel tangents to the outer surface of a cylindrical object

Visible class:

71CE7A72B6DA7-002 cutting tool library

Applicable classes:

71EC56E106606-001	flat wire compression spring
71EC56E04199D-001	helical coil spring
71EC56E0D4D19-001	helical disk spring

71CF29872F0AB-001001 X1

ISO/TS 13399-5:2014(E)

NON_QUANTITATIVE_CODE_TYPE

hand **hand** HAND

identifier used for the direction of rotation of rotating tool items and rotating adaptive items and for the position of the cutting edge of a stationary tool item, for the position of the connection used for a tool item or adaptive item with respect to the axis of the item, and for the orientation of a replaceable cutting item with respect to the insert reference system and for the orientation of a clamp

ISO 3002-1

Visible class:

71CE7A72B6DA7-002 cutting tool library

Applicable classes:

71D1AA486FF89-002	equilateral equiangular
71D1AE11B8B77-002	equilateral nonequiangular
71EC56B608ADC-001	insert wedge
71FAD54E2FE26-001	lever top clamp
71D0808DA853B-002	master insert
7224CCDD587CF-001	non replaceable cutting item
71D1AE120D96E-002	nonequilateral equiangular
71D1AA489FD6E-002	nonequilateral nonequiangular
71DDA089C8D1E-002	specific profile insert
71E01A004C775-002	tool item type

Allowed values:

R = right hand

L = left hand

N = neutral (both) hand

71EC61D8F250D-001 **001** **NR2 S.3.3**

REAL_MEASURE_TYPE mm

height **hth** HTH

largest dimension of an object above a base level

Illustration reference: 71FC0A6FF9CF8-1

Visible class:

71CE7A72B6DA7-002 **cutting tool library**

Applicable classes:

71EC56E223664-001 leaf spring

71CEAEBF2A69F-001 001 X17

STRING_TYPE

insert seat size code ssc SSC

identifier for the size of a replaceable cutting item and the seat on a tool item or an assembly item

NOTE The value of this identifier depends on both the shape of the cutting item and the size of the cutting item.

Visible class:

71CE7A72B6DA7-002 cutting tool library

Applicable classes:

71E01A04C377D-002	broach
71D1066F279AD-002	cartridge
71E01A00BD93C-002	drill
71D0808DA853B-002	master insert
71EAD70F1B95A-001	nest
71E01A04A8AEC-002	ream
71E0251F304E1-002	rotating borer
71E01A05104CF-002	turn

71CE7A9F0C79F-001 001 X17

NON_QUANTITATIVE_CODE_TYPE

insert shape code sc SC

identifier for the shape of a regular insert

ISO 1832:2012, Clause 4.1

Visible class:

71CE7A72B6DA7-002 cutting tool library

Applicable classes:

71D1AA486FF89-002	equilateral equiangular
71D1AE11B8B77-002	equilateral nonequiangular
71D0808DA853B-002	master insert
71EAD70F1B95A-001	nest
71D1AE120D96E-002	nonequilateral equiangular
71D1AA489FD6E-002	nonequilateral nonequiangular
71D1AA6635E76-002	round insert

Allowed values:

ISO/TS 13399-5:2014(E)

T = triangular 60° included angle

S = square

C = rhombic 80° included angle

D = rhombic 55° included angle

E = rhombic 75° included angle

M = rhombic 86° included angle

V = rhombic 35° included angle

L = rectangular

A = parallelogram 85° included angle

B = parallelogram 82° included angle

K = parallelogram 55° included angle

P = pentagonal

H = hexagonal

W = trigon

O = octagonal

R = round

71EC61D6B66E6-001 **001** **NR2 S.3.3**

REAL_MEASURE_TYPE mm

length **lth** **LTH**

distance between the ends of an object or feature

Visible class:

71CE7A72B6DA7-002 **cutting tool library**

Applicable classes:

71FAD519268DE-001 centre pin

71EC56E106606-001 flat wire compression spring

71EC56E223664-001 leaf spring

71EC5E54A9B4F-001 **001** **X17**

NON_QUANTITATIVE_CODE_TYPE

pin end shape **pnes** **PNES**

identifier for the form of the top termination of a rigid centre pin

Visible class:

71CE7A72B6DA7-002 **cutting tool library**

Applicable classes:

71FAD519268DE-001 centre pin

Allowed values:

cyl = cylindrical

con = conical

71FAD53253A1B-002 002 X2

NON_QUANTITATIVE_CODE_TYPE

pin fixing method pnfX PNFx

mechanism for securing a rigid centre pin in a tool item

Visible class:**71CE7A72B6DA7-002 cutting tool library****Applicable classes:**

71FAD519268DE-001 centre pin

Allowed values:

no = no fixing method

TH = threaded hole

ET = external thread

GL = groove for locking pin

71EC65A21E9D4-002 002 X4

NON_QUANTITATIVE_CODE_TYPE

section style scty SCTY

description of the shape of the cross section of an object or feature

Visible class:**71CE7A72B6DA7-002 cutting tool library****Applicable classes:**

71EC56E04199D-001 helical coil spring

Allowed values:

CIRC = circular

SQUA = square

TECT = rectangular

PROF = profiled

71FAD52B8F653-001 001 NR2 S.3.3

REAL_MEASURE_TYPE

mm

shaft diameter

sfdm

SFDM

width of the main functional portion of a cylindrical object

Visible class:

71CE7A72B6DA7-002 cutting tool library

Applicable classes:

71FAD519268DE-001

centre pin

71FAD52C3FC9E-001

001

NR2 S.3.3

REAL_MEASURE_TYPE

mm

shaft length

sftl

SFTL

longitudinal dimension of the main functional portion of a cylindrical object

Visible class:

71CE7A72B6DA7-002 cutting tool library

Applicable classes:

71FAD519268DE-001

centre pin

71FAE06BBB597-001

001

NR2 S.3.3

REAL_MEASURE_TYPE

N/m

spring coefficient

spcf

SPCF

ratio between the applied force and the reciprocal of the deflection

Visible class:

71CE7A72B6DA7-002 cutting tool library

Applicable classes:

71EC56BA16ACB-001

spring

71EAC4A2B6544-001

001

NR2 S.3.3

REAL_MEASURE_TYPE

deg

taper angle

ta

TA

included angle between generatrices in the axial plane section

ISO 1119

Visible class:

71CE7A72B6DA7-002 cutting tool library**Applicable classes:**

726F59BDC3B08-002	collet
71E01A0751456-002	conical drill
71E01A0E34C7F-001	conical tap
71E01A06A8A08-002	countersink drill
71E01A05D27A8-002	end mill
71E01A0540BE7-002	slab mill
71EF07E037025-002	slotting cutter
71E01A081855D-002	tapered broach
71E01A07D2A1B-001	tapered reamer

71CEAEC02FEBD-001 001 NR2 S.3.3

REAL_TYPE

taper gradient tg TG

ratio of the difference between the diameters of two sections to the distance between these sections
ISO 1119

REMARKS Also known as rate of taper.

Illustration reference: 71FC1960E0485-1**Visible class:****71CE7A72B6DA7-002 cutting tool library****Applicable classes:**

726F59BDC3B08-002	collet
71E01A0751456-002	conical drill
71E01A0E34C7F-001	conical tap
71E01A06A8A08-002	countersink drill
71E01A05D27A8-002	end mill
71E01A0540BE7-002	slab mill
71EF07E037025-002	slotting cutter
71E01A081855D-002	tapered broach
71E01A07D2A1B-001	tapered reamer
71DD700C151B5-002	threading profile

Annex E
(informative)

Illustrations of assembly item classes

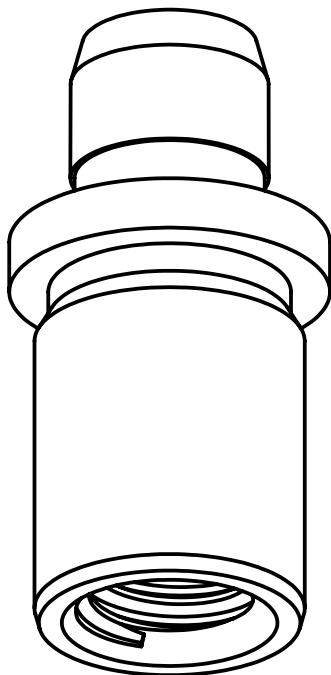

Figure E.1 — Centre pin

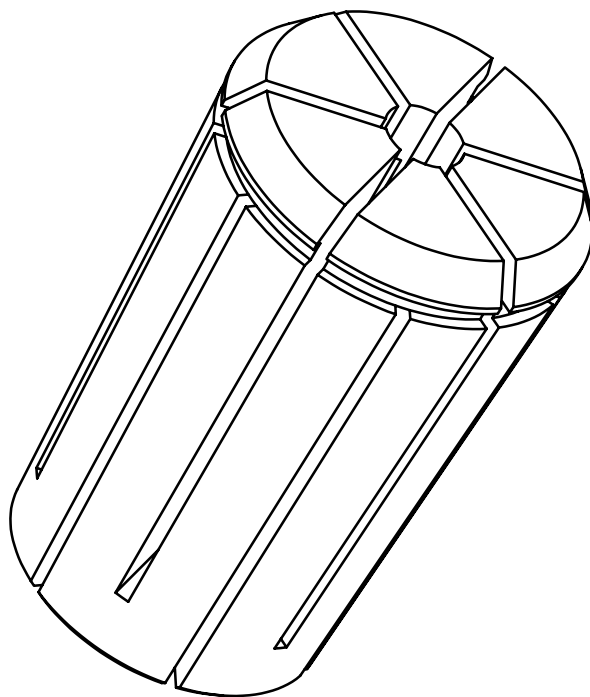

Figure E.2 — Collet

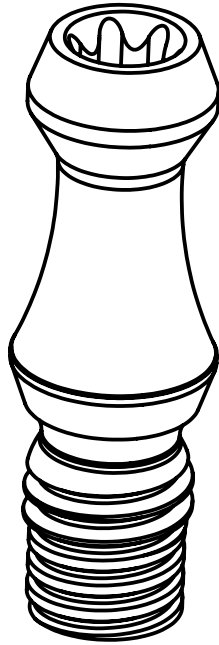

Figure E.3 — Deflection screw

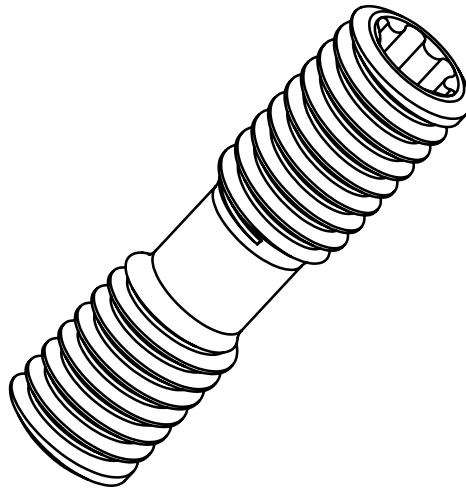

Figure E.4 — Differential screw

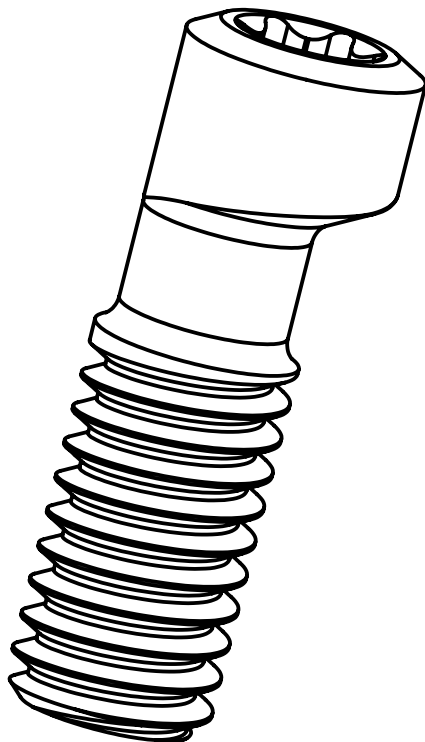

Figure E.5 — Eccentric screw

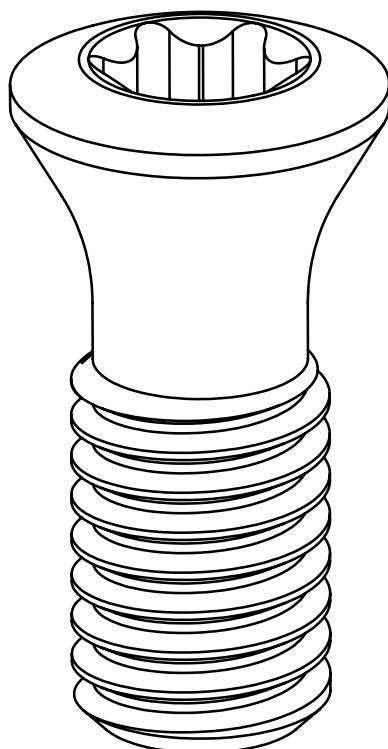

Figure E.6 — Insert screw

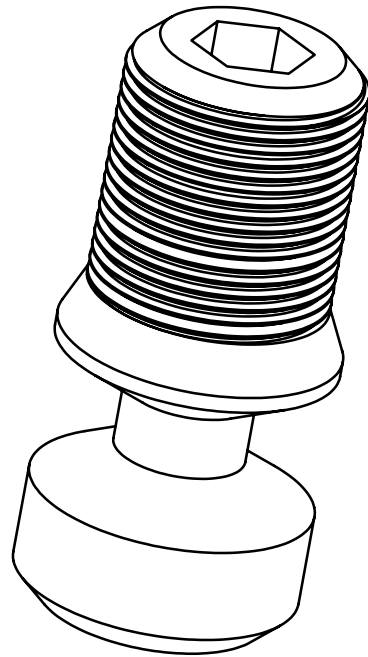

Figure E.7 — Lever screw

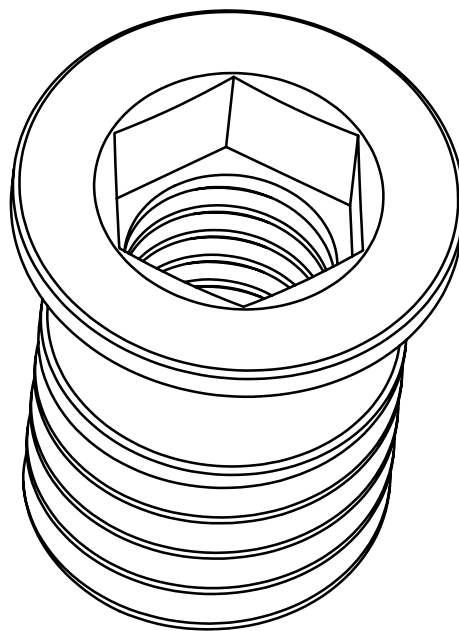

Figure E.8 — Hollow screw

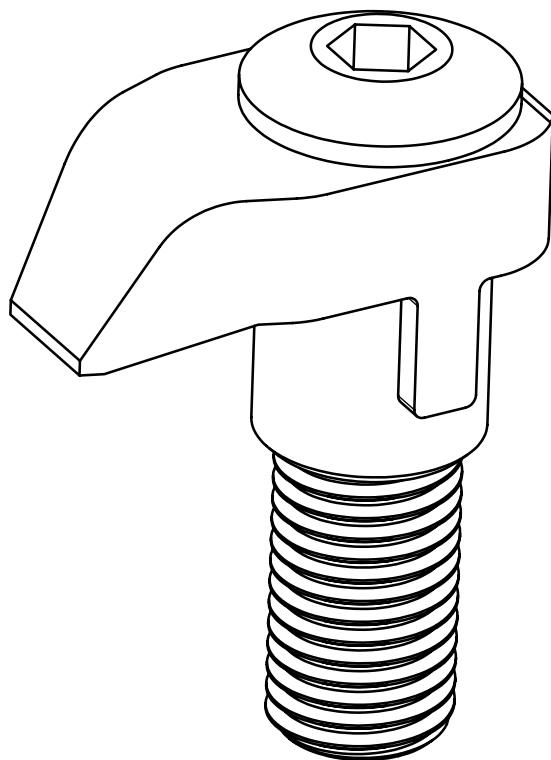

Figure E.9 — Cantilever clamp

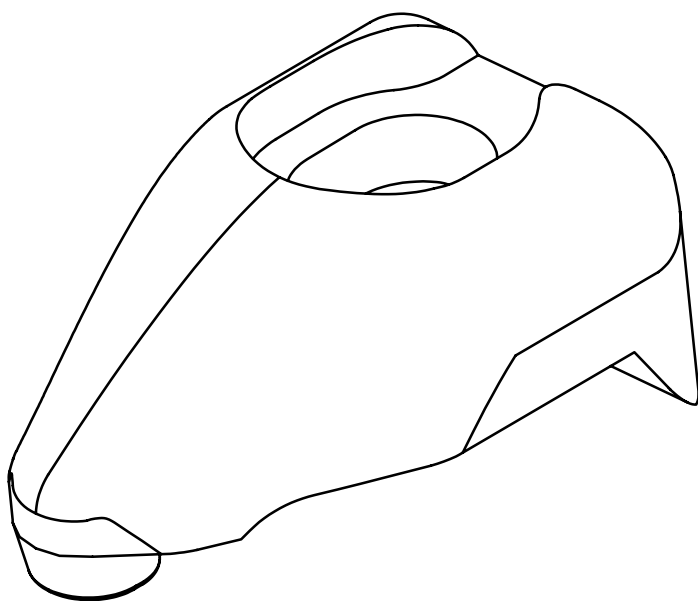

Figure E.10 — Floating wedge clamp

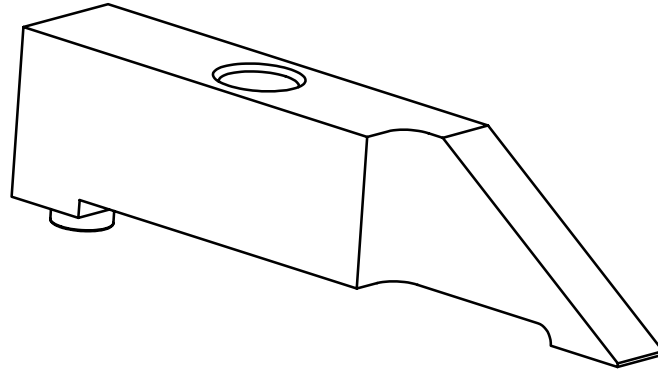

Figure E.11 — Lever top clamp

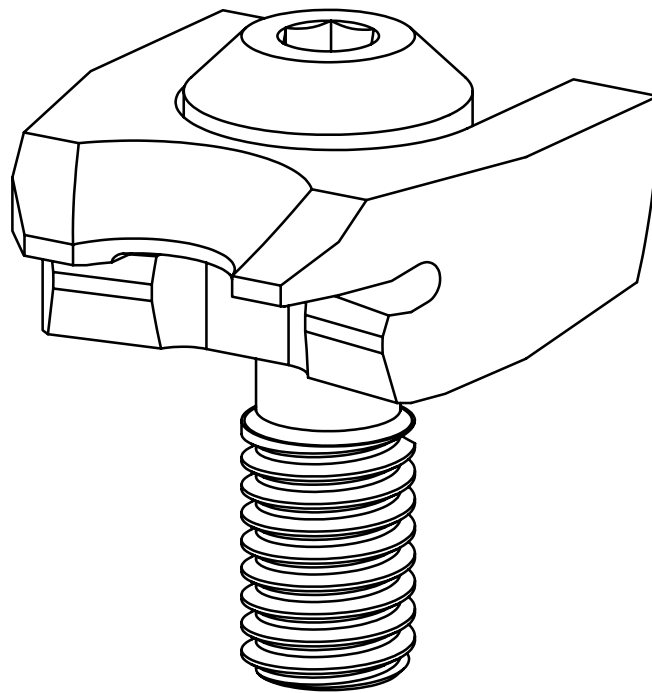

Figure E.12 — Wedge clamp

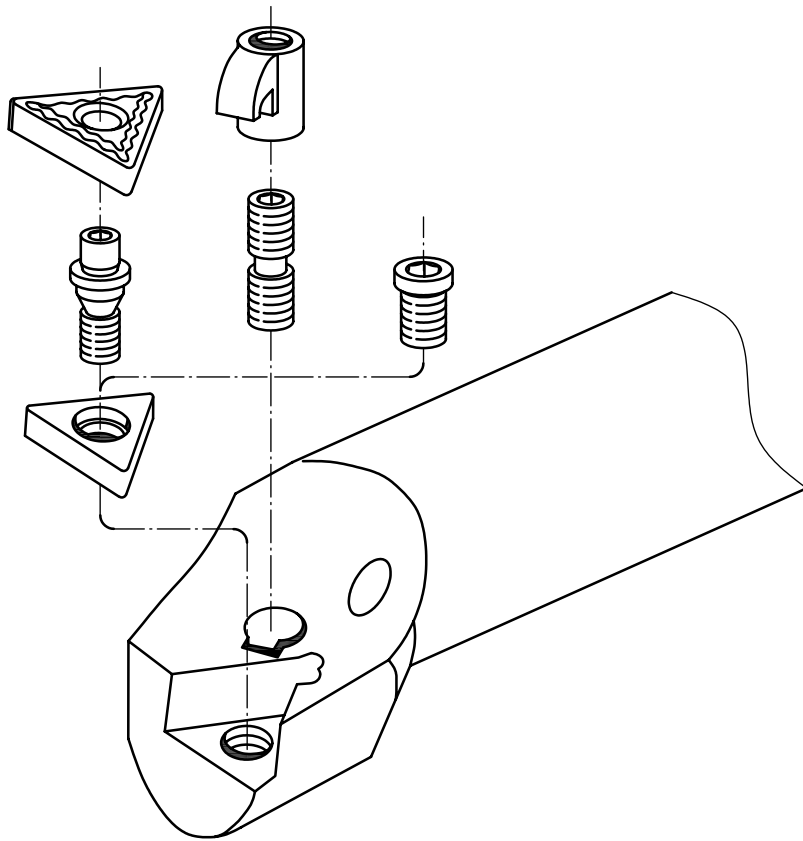

Figure E.13 — Cantilever clamping

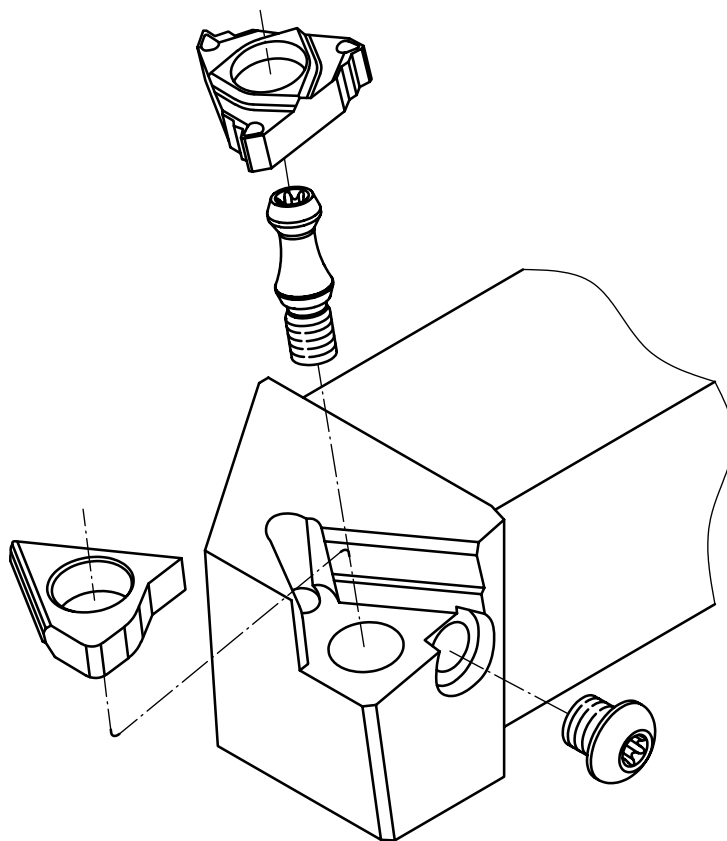

Figure E.14 — Deflection screw clamping

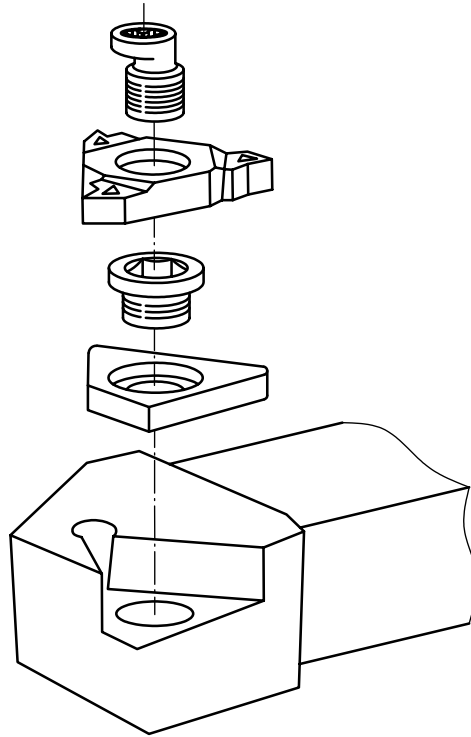

Figure E.15 — Eccentric screw clamping

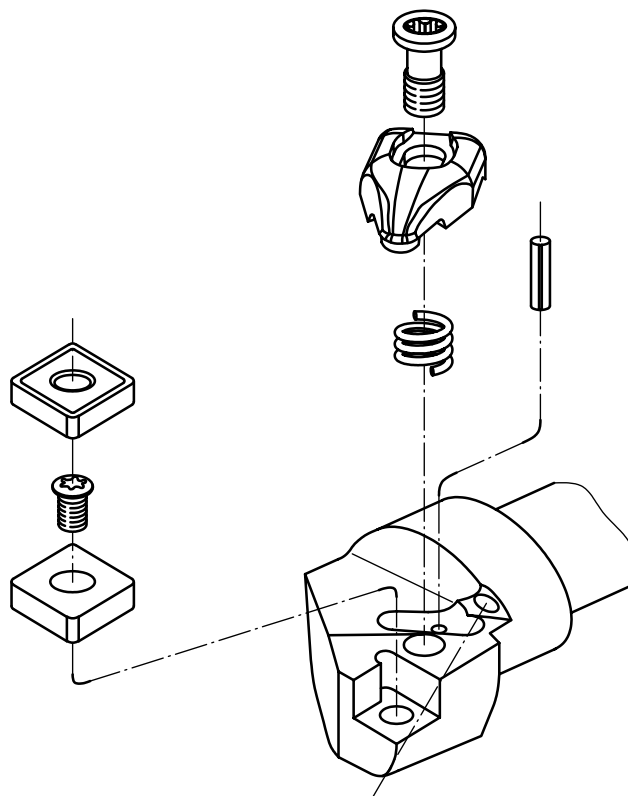

Figure E.16 — Floating wedge clamping

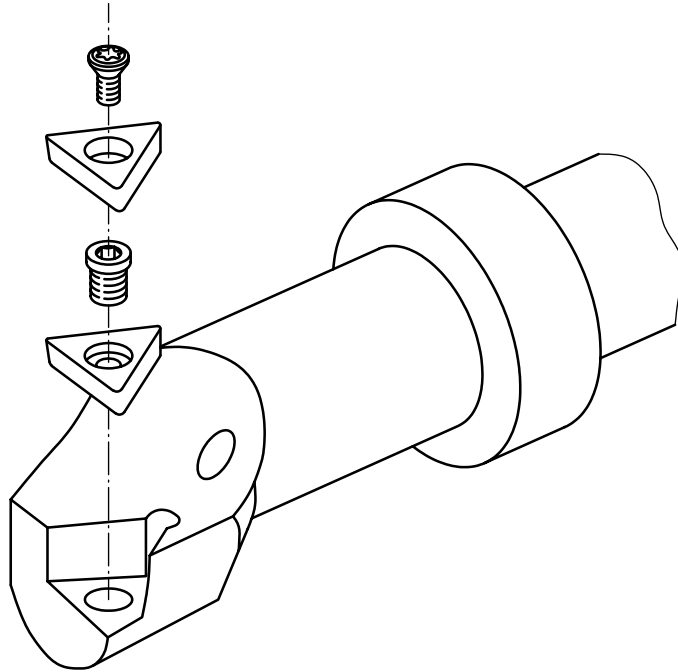

Figure E.17 — Insert screw clamping

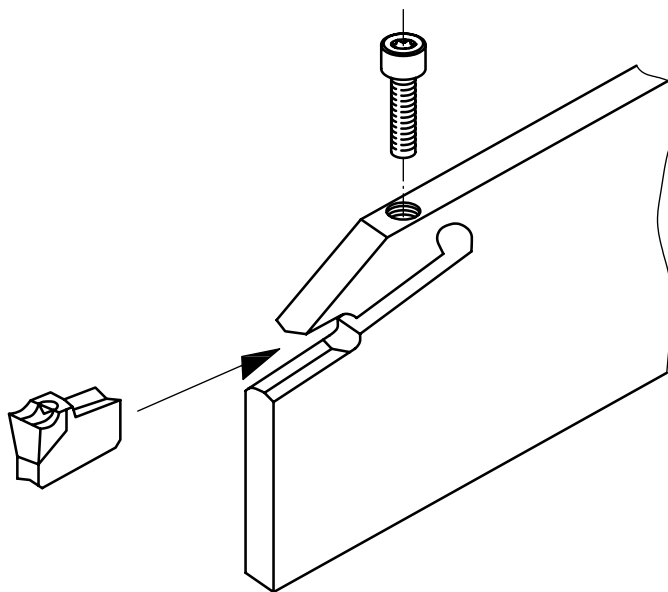

Figure E.18 — Integrated clamping

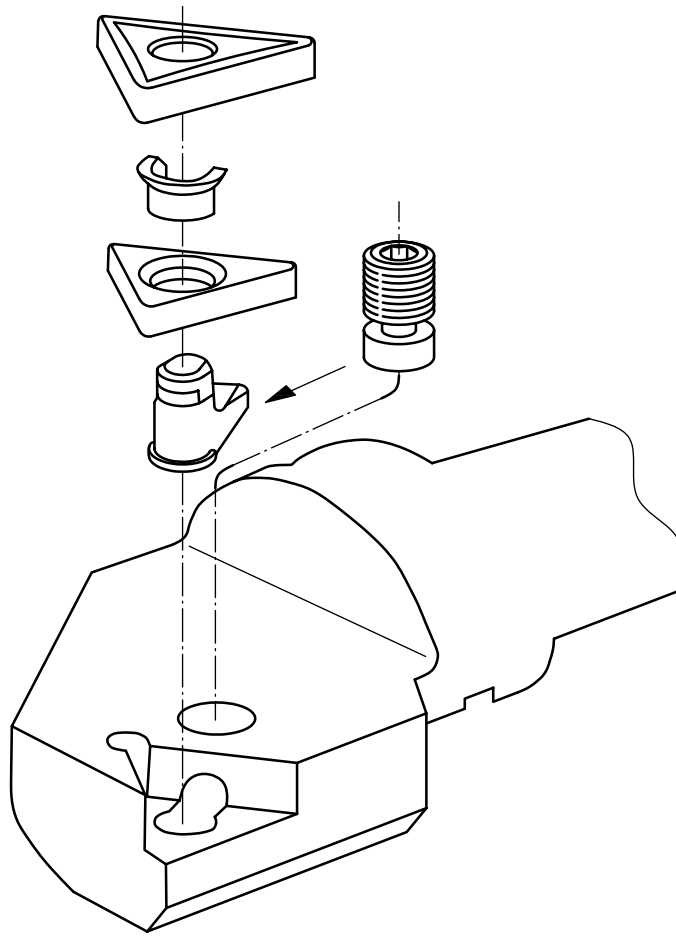

Figure E.19 — Lever insert clamping

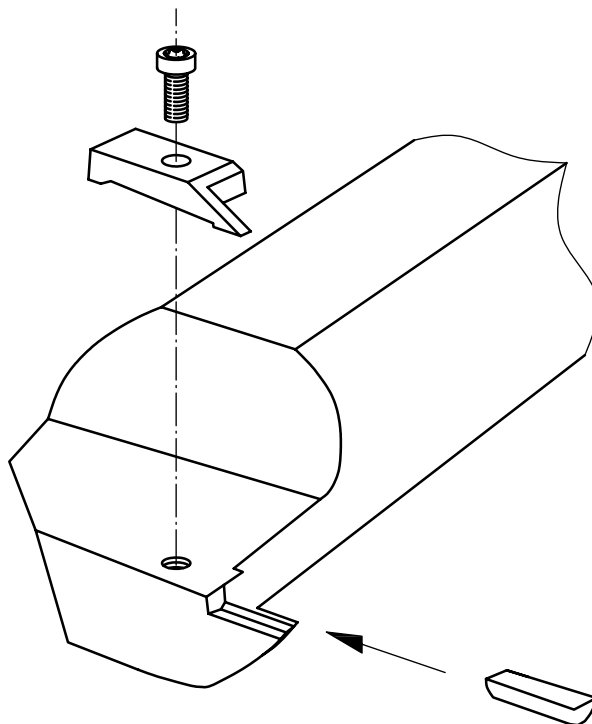

Figure E.20 — Top clamping

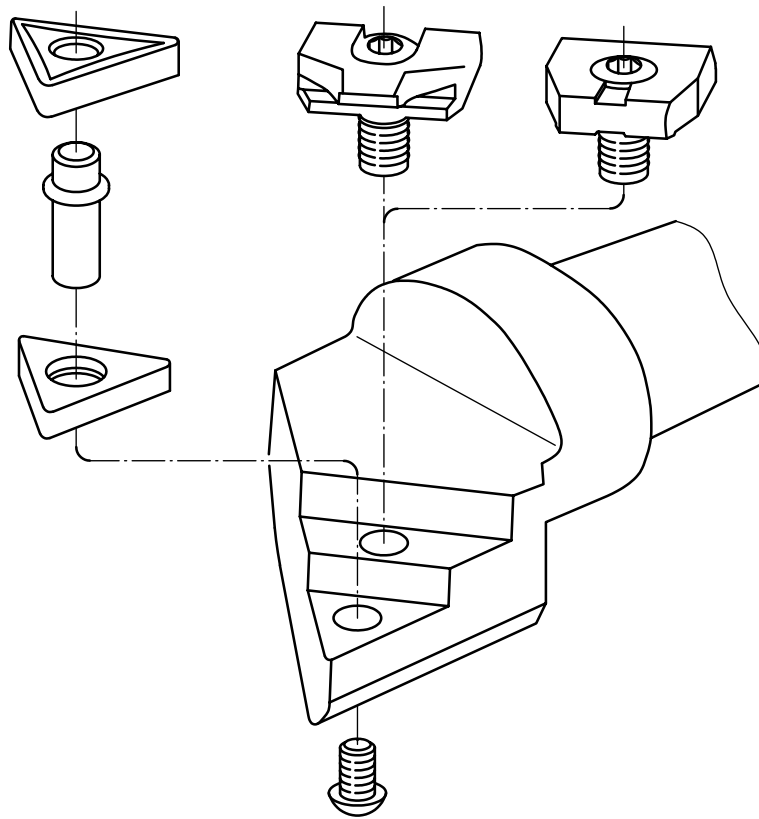

Figure E.21 — Wedge clamping

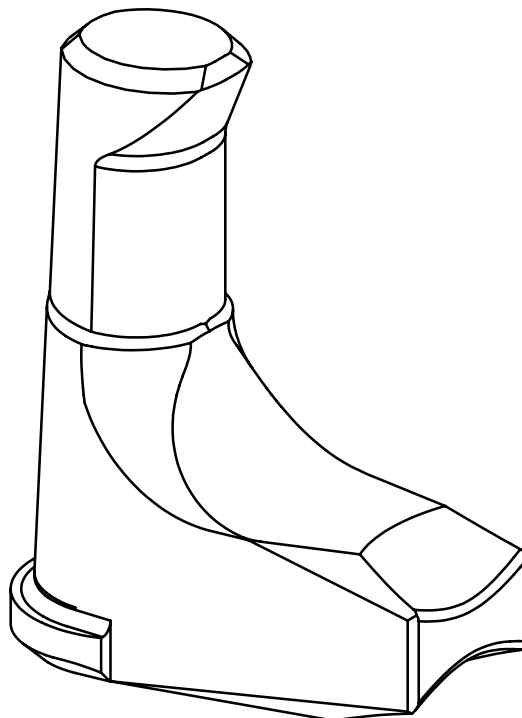

Figure E.22 — Insert lever

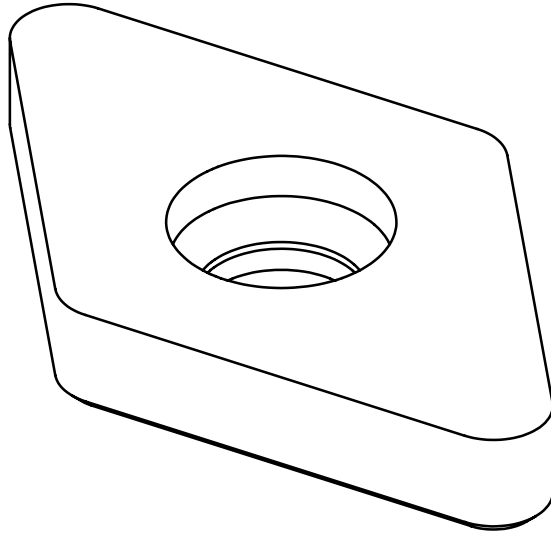

Figure E.23 — Insert shim

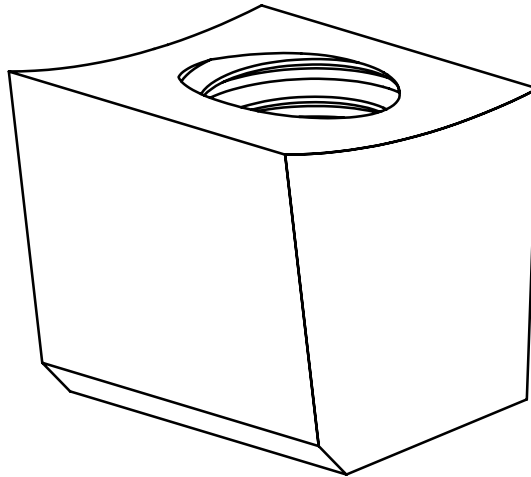

Figure E.24 — Insert wedge

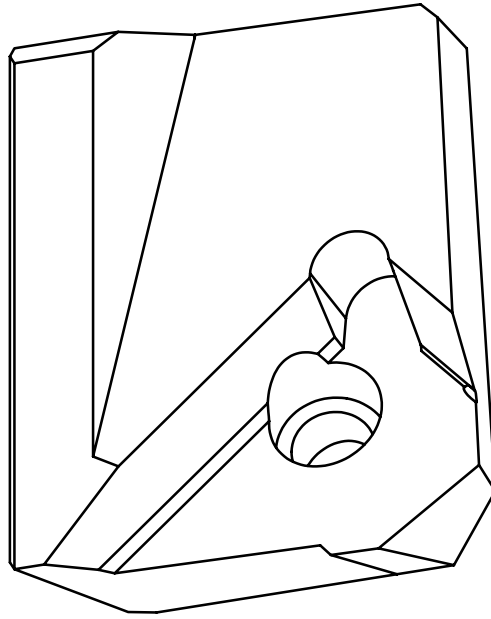

Figure E.25 — Nest

Bibliography

- [1] ISO 10303-1:1994, *Industrial automation systems and integration — Product data representation and exchange — Part 1: Overview and fundamental principles*
- [2] ISO 10303-11:2004, *Industrial automation systems and integration — Product data representation and exchange — Part 11: Description methods: The EXPRESS language reference manual*
- [3] ISO 10303-21:2002, *Industrial automation systems and integration — Product data representation and exchange — Part 21: Implementation methods: Clear text encoding of the exchange structure*
- [4] ISO 13399-1:2006, *Cutting tool data representation and exchange — Part 1: Overview, fundamental principles and general information model*
- [5] ISO/TS 13399-2, *Cutting tool data representation and exchange — Part 2: Reference dictionary for the cutting items*
- [6] ISO 13584-1:2001, *Industrial automation systems and integration — Parts library — Part 1: Overview and fundamental principles*
- [7] ISO 13584-24:2003, *Industrial automation systems and integration — Parts library — Part 24: Logical resource: Logical model of supplier library*
- [8] ISO 13584-26:2000, *Industrial automation systems and integration — Parts library — Part 26: Logical resource: Information supplier identification*
- [9] ISO 13584-42:2010, *Industrial automation systems and integration — Parts library — Part 42: Description methodology: Methodology for structuring parts families*

