**Cutting tool data representation and
exchange —**

Part 302:

**Concept for the design of 3D models
based on properties according to ISO/
TS 13399-3: Modelling of solid drills
and countersinking tools**

Représentation et échange des données relatives aux outils coupants —

*Partie 302: Description des modèles 3D basés sur les propriétés de l'ISO/
TS 13399-3: Modélisation des forets monoblocs et des outils de lamage*





COPYRIGHT PROTECTED DOCUMENT

© ISO 2013

All rights reserved. Unless otherwise specified, no part of this publication may be reproduced or utilized otherwise in any form or by any means, electronic or mechanical, including photocopying, or posting on the internet or an intranet, without prior written permission. Permission can be requested from either ISO at the address below or ISO's member body in the country of the requester.

ISO copyright office
Case postale 56 • CH-1211 Geneva 20
Tel. + 41 22 749 01 11
Fax + 41 22 749 09 47
E-mail copyright@iso.org
Web www.iso.org

Published in Switzerland

Contents

	Page
Foreword	v
Introduction	vii
1 Scope	1
2 Normative references	1
3 Starting elements, coordinate systems, planes	1
3.1 General.....	1
3.2 Reference system.....	2
3.3 Coordinate system at the cutting part.....	2
3.4 MCS coordinate system.....	3
3.5 Planes.....	4
3.6 Cutting reference point (CRP).....	4
4 Design of the model	5
4.1 General.....	5
4.2 Necessary parameters for the connection interface feature.....	6
5 Twist drill	6
5.1 General.....	6
5.2 Necessary properties.....	7
5.3 Geometry of the non-cutting part including the connection.....	8
5.4 Geometry of the cutting part.....	8
5.5 Twist drill — Complete.....	9
6 Step drill	10
6.1 General.....	10
6.2 Necessary properties.....	10
6.3 Geometry of the non-cutting part including the connection.....	11
6.4 Geometry of the cutting part.....	11
6.5 Step drill — Complete.....	12
7 Core drill	12
7.1 General.....	12
7.2 Necessary properties.....	13
7.3 Geometry of the non-cutting part including the connection.....	14
7.4 Geometry of the cutting part.....	14
7.5 Core drill — Complete.....	15
8 Counterbore	15
8.1 General.....	15
8.2 Necessary properties.....	16
8.3 Geometry of the non-cutting part including the connection.....	16
8.4 Geometry of the cutting part.....	16
8.5 Counterbore — Complete.....	17
9 Stepped countersinking tool or tapered countersinking tool	18
9.1 General.....	18
9.2 Necessary properties.....	19
9.3 Geometry of the non-cutting part including the connection.....	20
9.4 Geometry of the cutting part.....	20
9.5 Stepped or tapered countersinking tool — Complete.....	22
10 Spot drill	23
10.1 General.....	23
10.2 Necessary properties.....	23
10.3 Geometry of the non-cutting part including the connection.....	24
10.4 Geometry of the cutting part.....	24
10.5 Spot drill — Complete.....	25

11	Centre drill	25
	11.1 General.....	25
	11.2 Necessary properties.....	27
	11.3 Geometry of the non-cutting part including the connection.....	28
	11.4 Geometry of the cutting part.....	28
	11.5 Centre drill — Complete.....	29
12	Shell core drills	30
	12.1 General.....	30
	12.2 Necessary properties.....	31
	12.3 Geometry of the non-cutting part.....	32
	12.4 Geometry of the cutting part.....	33
	12.5 Shell core drill — Complete.....	34
13	Shell counterbore	34
	13.1 General.....	34
	13.2 Necessary properties.....	35
	13.3 Geometry of the non-cutting part.....	35
	13.4 Geometry of the cutting part.....	35
	13.5 Shell counterbore — Complete.....	35
14	Tapered shell countersinking tool	36
	14.1 General.....	36
	14.2 Necessary properties.....	37
	14.3 Geometry of the non-cutting part.....	37
	14.4 Geometry of the cutting part.....	38
	14.5 Tapered shell countersinking tool.....	38
15	Stepped shell countersinking tool	38
	15.1 General.....	38
	15.2 Necessary properties.....	39
	15.3 Geometry of the non-cutting part.....	39
	15.4 Geometry of the cutting part.....	40
	15.5 Stepped shell countersinking tool complete.....	40
16	Modelling of guide pilots	40
	16.1 General.....	40
	16.2 Necessary properties.....	41
	16.3 Guide pilot.....	41
17	Design of details	42
	17.1 Basis for modelling.....	42
	17.2 Contact/clamping surfaces — Orientation.....	42
	17.3 Chamfers, roundings, others.....	43
18	Attributes of surfaces — Visualization of model features	43
19	Structure of design elements (tree of model)	43
20	Data exchange model	44
	Annex A (informative) Information about nominal dimensions	45
	Bibliography	46

Foreword

ISO (the International Organization for Standardization) is a worldwide federation of national standards bodies (ISO member bodies). The work of preparing International Standards is normally carried out through ISO technical committees. Each member body interested in a subject for which a technical committee has been established has the right to be represented on that committee. International organizations, governmental and non-governmental, in liaison with ISO, also take part in the work. ISO collaborates closely with the International Electrotechnical Commission (IEC) on all matters of electrotechnical standardization.

The procedures used to develop this document and those intended for its further maintenance are described in the ISO/IEC Directives, Part 1. In particular the different approval criteria needed for the different types of ISO documents should be noted. This document was drafted in accordance with the editorial rules of the ISO/IEC Directives, Part 2. www.iso.org/directives

Attention is drawn to the possibility that some of the elements of this document may be the subject of patent rights. ISO shall not be held responsible for identifying any or all such patent rights. Details of any patent rights identified during the development of the document will be in the Introduction and/or on the ISO list of patent declarations received. www.iso.org/patents

Any trade name used in this document is information given for the convenience of users and does not constitute an endorsement.

For an explanation on the meaning of ISO specific terms and expressions related to conformity assessment, as well as information about ISO's adherence to the WTO principles in the Technical Barriers to Trade (TBT) see the following URL: Foreword - Supplementary information

The committee responsible for this document is ISO/TC 29, *Small tools*.

ISO/TS 13399 consists of the following parts, under the general title *Cutting tool data representation and exchange*:

- *Part 1: Overview, fundamental principles and general information model*
- *Part 2: Reference dictionary for the cutting items* [Technical Specification]
- *Part 3: Reference dictionary for tool items* [Technical Specification]
- *Part 4: Reference dictionary for adaptive items* [Technical Specification]
- *Part 5: Reference dictionary for assembly items* [Technical Specification]
- *Part 50: Reference dictionary for reference systems and common concepts* [Technical Specification]
- *Part 60: Reference dictionary for connection systems* [Technical Specification]
- *Part 100: Definitions, principles and methods for reference dictionaries* [Technical Specification]
- *Part 150: Usage guidelines* [Technical Specification]
- *Part 301: Concept for the design of 3D models based on properties according to ISO/TS 13399-3: Modelling of thread-cutting taps, thread-forming taps and thread-cutting dies* [Technical Specification]
- *Part 302: Concept for the design of 3D models based on properties according to ISO/TS 13399-3: Modelling of solid drills and countersinking tools* [Technical Specification]

The following parts are under preparation:

- *Part 51: Designation system for customer solution cutting tools*
- *Part 80: Concept for the design of 3D models based on properties according to ISO/TS 13399: Overview and principles* [Technical Specification]

- *Part 201: Concept for the design of 3D models based on properties according to ISO/TS 13399-2: Modelling of regular inserts [Technical Specification]*
- *Part 202: Concept for the design of 3D models based on properties according to ISO/TS 13399-2: Modelling of irregular inserts [Technical Specification]*
- *Part 203: Concept for the design of 3D models based on properties according to ISO/TS 13399-2: Modelling of exchangeable inserts for drilling [Technical Specification]*
- *Part 204: Concept for the design of 3D models based on properties according to ISO/TS 13399-2: Modelling of inserts for reaming [Technical Specification]*
- *Part 303: Concept for the design of 3D models based on properties according to ISO/TS 13399-3: Modelling of end mills with solid cutting edges [Technical Specification]*
- *Part 304: Concept for the design of 3D models based on properties according to ISO/TS 13399-3: Modelling of milling cutters with arbor hole and solid cutting edges [Technical Specification]*
- *Part 307: Concept for the design of 3D models based on properties according to ISO/TS 13399-3: Modelling of end mills for indexable inserts [Technical Specification]*
- *Part 308: Concept for the design of 3D models based on properties according to ISO/TS 13399-3: Modelling of milling cutter with arbor hole for indexable inserts [Technical Specification]*
- *Part 309: Concept for the design of 3D models based on properties according to ISO/TS 13399-3: Tool holders for indexable inserts [Technical Specification]*
- *Part 311: Concept for the design of 3D models based on properties according to ISO/TS 13399-3: Modelling of solid reamers [Technical Specification]*
- *Part 312: Concept for the design of 3D models based on properties according to ISO/TS 13399-3: Modelling of reamers for indexable inserts [Technical Specification]*
- *Part 401: Concept for the design of 3D models based on properties according to ISO/TS 13399-4: Modelling of converting, extending and reducing adaptive items [Technical Specification]*
- *Part 405: Concept for the design of 3D models based on properties according to ISO/TS 13399-4: Modelling of collets [Technical Specification]*

Introduction

This part of ISO 13399 describes the concept, terms and definitions for designing simplified 3D models of drills and countersinking tools with solid cutting edges, which can be used for NC programming, simulation of manufacturing processes and the avoidance of collisions within machining processes. It is not intended to standardize the design of the cutting tool itself.

A cutting tool is used in a machine tool to remove material from a workpiece by a shearing action at the cutting edges of the tool. Cutting tool data that can be described by ISO 13399 (all parts) include, but are not limited to, everything between the workpiece and the machine tool. Information about inserts, solid tools, assembled tools, adaptors, components and their relationships can be represented by ISO 13399 (all parts). The increasing demand by the end user for 3D models for the purposes defined above is the basis for the development of this series of International Standards.

The objective of ISO 13399 (all parts) is to provide the means to represent information describing cutting tools in computer-sensible form, independent of any particular computer system. The representation will facilitate the processing and exchange of cutting tool data within and among different software systems and computer platforms and support the application of these data in manufacturing planning, cutting operations and the supply of tools. The nature of this description makes it suitable not only for neutral file exchange, but also as a basis for implementing and sharing product databases and for archiving. The methods used for these representations are those developed by ISO/TC 184/SC 4 for the representation of product data by standardized information models and reference dictionaries.

Dictionary entries are defined and identified by means of standard data that consist of instances of the EXPRESS entity data types defined in the common dictionary schema, resulting from a joint effort between ISO/TC 184/SC 4 and IEC SC3D, and its extensions defined in ISO 13584-24 and ISO 13584-25.

Cutting tool data representation and exchange —

Part 302:

Concept for the design of 3D models based on properties according to ISO/TS 13399-3: Modelling of solid drills and countersinking tools

1 Scope

This part of ISO 13399 specifies a concept for the design of tool items, limited to any kind of drilling and countersinking tools with solid cutting edges, together with the usage of the related properties and domains of values.

This part of ISO 13399 specifies a common way of designing simplified models that contain:

- definitions and identifications of the design features of drills and countersinking tools with solid cutting edges, with a link to the properties used;
- definitions and identifications of the internal structure of the 3D model that represents the features and properties of drills and countersinking tools with solid cutting edges.

The following are outside the scope of this part of ISO 13399:

- applications where these standard data may be stored or referenced;
- concept of 3D models for cutting tools;
- concept of 3D models for cutting items;
- concept of 3D models for other tool items not described in the scope of this part of ISO 13399;
- concept of 3D models for adaptive items;
- concept of 3D models for assembly and auxiliary items.

2 Normative references

The following documents, in whole or in part, are normatively referenced in this document and are indispensable to its application. For dated references, only the edition cited applies. For undated references, the latest edition of the referenced document (including any amendments) applies.

ISO/TS 13399-3, *Cutting tool data representation and exchange — Part 3: Reference dictionary for tool items*

ISO/TS 13399-60, *Cutting tool data representation and exchange — Part 60: Reference dictionary for connection systems*

3 Starting elements, coordinate systems, planes

3.1 General

3D models shall be modelled by means of nominal dimensions.

WARNING — There is no guarantee that the 3D model, created according to the methods described in this part of ISO 13399, is a true representation of the physical tool supplied by the tool manufacturer. If the model is used for simulation purposes (e.g. CAM simulation), it shall be taken into consideration that the real product dimensions may differ from those nominal dimensions.

NOTE Some of the definitions have been taken from ISO/TS 13399-50.

3.2 Reference system

The reference system consists of the following standard elements:

- standard coordinate system;
- right-handed rectangular Cartesian system in three-dimensional space, named “primary coordinate system” (PCS);
- three orthogonal planes;
- planes in the coordinate system that contain the axes of the system, named “xy-plane” (XYP), “xz-plane” (XZP) and “yz-plane” (YZP);
- three orthogonal axis;
- axes built as intersections of the three orthogonal planes lines, named “X-axis” (XA), “Y-axis” (YA) and “Z-axis” (ZA), respectively.

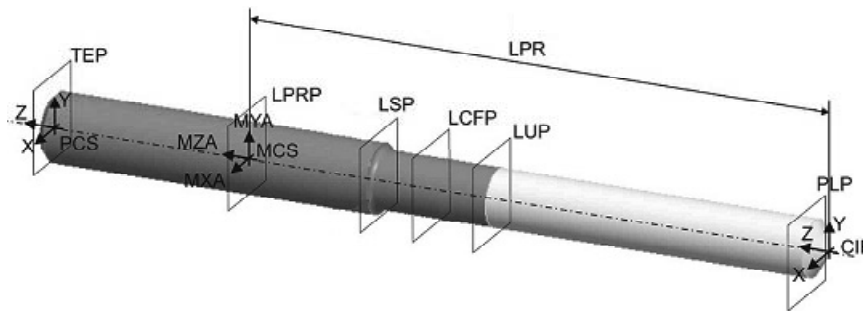

Figure 1 — Reference system

3.3 Coordinate system at the cutting part

The coordinate system at the cutting part, e.g. the drilling point or the planar countersunk face, named “coordinate system in process” (CIP), with a defined distance to the PCS shall be defined as indicated in [Figure 1](#) and oriented as indicated in [Figure 2](#) as follows:

- Z-axis of CIP points to the PCS;
- Z-axis of CIP is collinear to the Z-axis of PCS;
- Y-axis of CIP is parallel to the Y-axis of PCS.

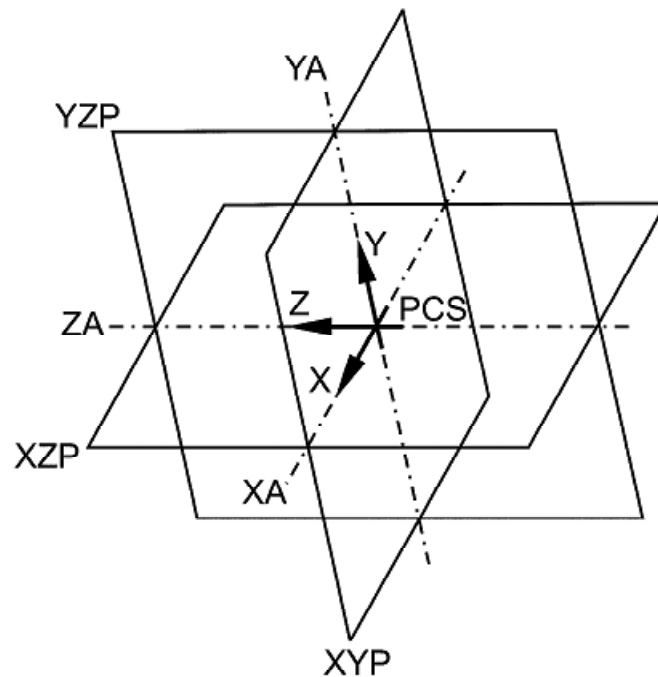

Figure 2 — Orientation of CIP

If the 3D modelling software gives the possibility to include interfaces for components, e.g. to mount a centre drill on to a complete cutting tool, it is advisable to use CIP.

If necessary, another designation has to be given on the interface of the component (dependent on the software). This is named “CSIF” (for “coordinate system interface”) and it includes the CIP.

3.4 MCS coordinate system

A “mounting coordinate system” (MCS) shall be inserted within the 3D model to allow mounting with other components, congruent to the PCS. [Figure 3](#) shows the orientation of MCS and PCS.

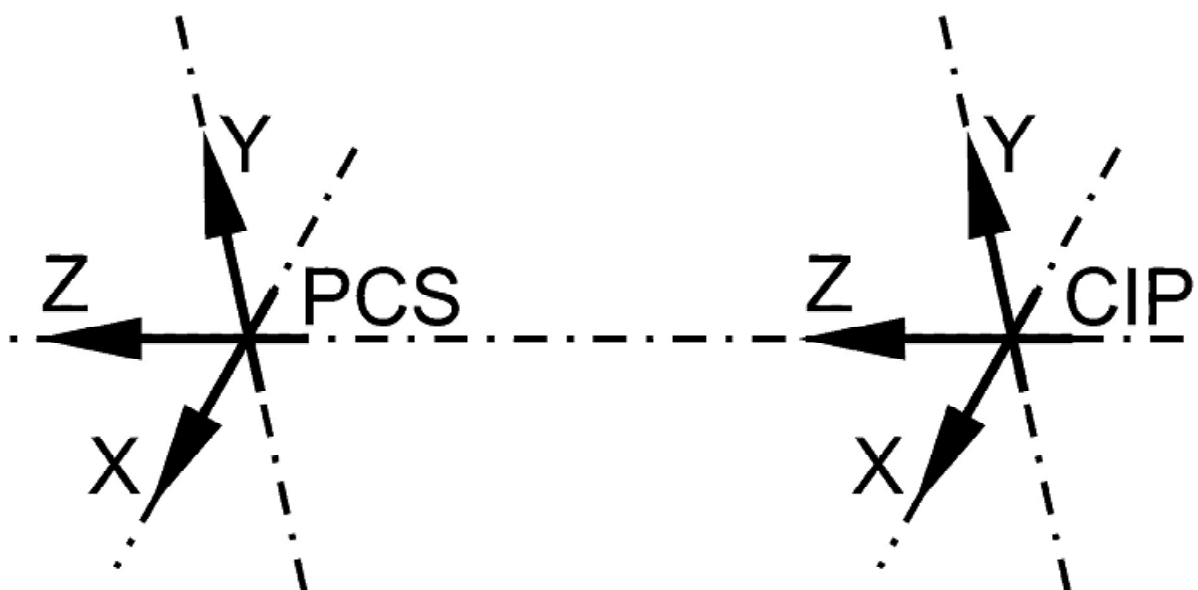

Figure 3 — Orientation of PCS and MCS reference system — Example

3.5 Planes

Modelling shall be based on planes according to [Figure 3](#), to be used as reference, if applicable. It is, therefore, possible to vary the model or to suppress single features of independent designs by changing the value of one or more parameter(s) of the model design. Furthermore, identification of different areas shall be simplified by using the plane concept, even if they come into contact with each other with the same size (e.g. chip flute, shank).

The interdependency of design features requires a precise check of single elements, mainly on drills with different diameters, which shall be entered separately, even if they have the same value.

For 3D visualization of drilling and countersinking tools with non-indexable cutting edges, the planes shall be determined as indicated in [Figure 4](#) as follows:

- “LCFP” plane for the chip flute length (LCF); based on CIP;
- “LPRP” plane for the protruding length (LPR); based on CIP;
- “LSP” plane for the shank length (LS); based on PCS;
- “LUP” plane for the usable length (LU); based on CIP;
- “PLP” plane for the distance between the front cutting point and the point that forms the full cutting diameter, measured parallel to the tool axis; based on CIP;
- “TEP” (tool end plane) plane for the overall length (OAL); based on CIP;
- MCS is located at the defined tool item position, if gauge lines are defined, or at the start of the protruding length [see LPRP (protruding length plane)].

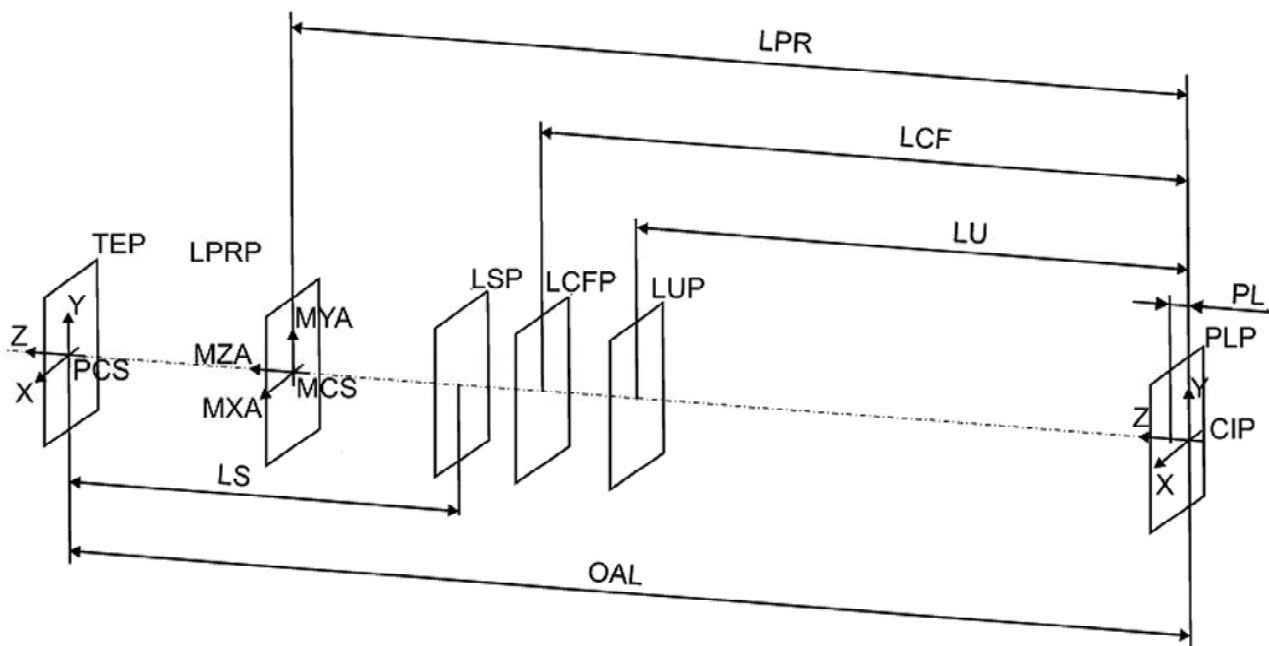

Figure 4 — Planes for design

3.6 Cutting reference point (CRP)

For the design of the point or chisel edge the cutting reference point shall be defined. The point is defined as the theoretical cutting edge in the XZ plane of the “PCS”. It is, therefore, always referenced to the cutting diameter (see [Figure 5](#)).

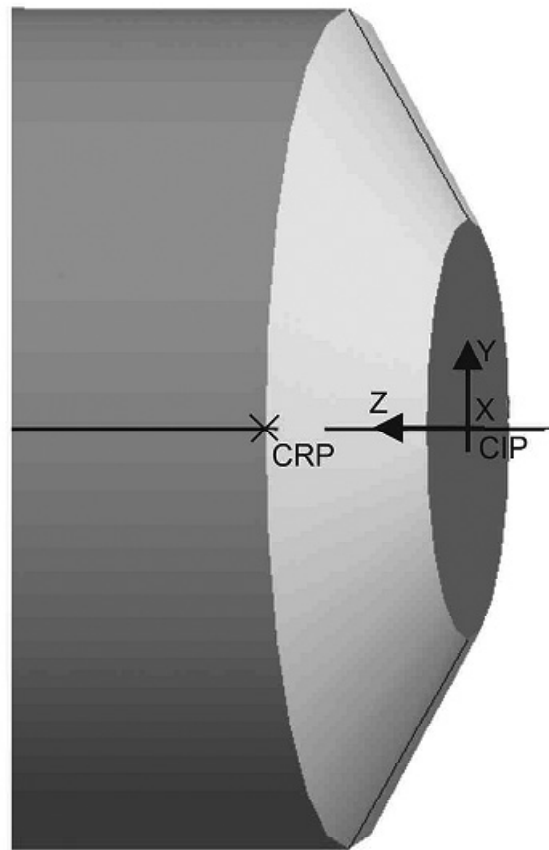

Figure 5 — Position of the CRP cutting reference point

4 Design of the model

4.1 General

Sketches and contours of the crude geometry do not contain any details, such as grooves, chamfers or rounding. These details shall be designed as separate design features, after the design of the crude geometry and are, therefore, named precision geometry.

The order of the structure of the model depends on the state of the technology of the CAD system. It shall be waived on references between the design components of the cutting and non-cutting part.

Drilling and countersinking tools with non-replaceable cutting edges shall be built as rotational symmetric design elements based on properties in accordance with ISO/TS 13399-3:

- geometry of the non-cutting part, including the connection interface, if applicable;
- geometry of the cutting part.

NOTE 1 Both these geometrical parts are coloured as described in [Clause 18](#).

NOTE 2 The totality of design elements is focused on the depth of modelling and the complexity of the cutting tool.

The following subclauses describe the specified structure of the model of the defined basic shapes of drilling and countersinking tools .

The section of “CUT” area ends at the LUP, if the LCF is larger than the LU, and ends at the LCFP, if the usable length is larger than the LCF.

Examples of the design of different tool types are shown with a cylindrical shank or circular bore representing the connection interface feature.

4.2 Necessary parameters for the connection interface feature

Information about the connection interface code shall be filed as properties within the model and named as parameters as indicated in [Table 1](#):

Table 1 — Parameter list for connection interface feature

Preferred symbol	Description	Source of symbol	ISO-ID number
CCMS	connection code machine side	ISO/TS 13399-3 and ISO/TS 13399-4	71D102AE3B252
CCTMS	connection code type machine side	ISO/TS 13399-60 short name of subtype of connection_interface_feature	feature_class
CCFMS	connection code form machine side	ISO/TS 13399-60 number of the variant of the subtype of connection_interface_feature	feature_class
CZCMS	connection size code machine side	connection size code (dependent on side)	71FC193318002

The information above and other relevant properties shall be incorporated into the model as parameters or else recorded as a separate file.

5 Twist drill

5.1 General

[Figure 6](#) shows the properties used for identification and classification of twist drills.

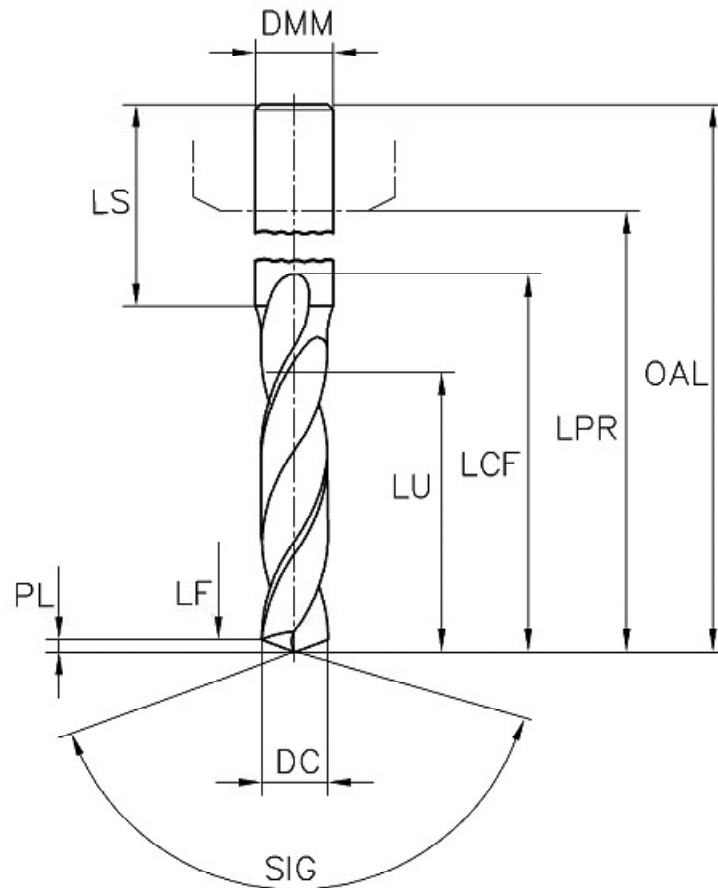

Figure 6 — Solid drill — Determination of properties

5.2 Necessary properties

Table 2 shows the properties needed for the modelling of a twist drill

Table 2 — Properties for the modelling of a twist drill

Preferred name	Preferred symbol
cutting diameter	DC
protruding length	LPR
usable length	LU
overall length	OAL
length chip flute	LCF
point length	PL
functional length	LF
connection thread nominal size machine side	THSZMS
shank diameter	DMM
shank length	LS
point angle	SIG

The properties LPR and LF shall be employed in the parameter list of the model, if they are well defined.

The property “PL” can be calculated from a function using the terms DMM and SIG terms, but for practical reasons, this property shall be used as a reference dimension.

5.3 Geometry of the non-cutting part including the connection

The basis of this part is a rotational design feature, containing all elements between the TEP and LUP planes.

The sketch includes all the elements indicated in [Figure 7](#) and shall be designed on the YZ plane of the PCS. The rotational axis is the standard z-axis.

Design of the sketch:

- the sketch shall be determined as a half section;
- the sketch shall be constrained to the coordinate system PCS and to the planes TEP and LUP according to [Figure 7](#). If the CAD software does not support the use of datum planes, the sketch shall be fully dimensioned; otherwise, the distances shall be in conjunction with the defined datum planes;
- dimensioning shall be done with the appropriate properties listed in [Table 2](#).

The sketch shall be rotated about the Z-axis through 360°.

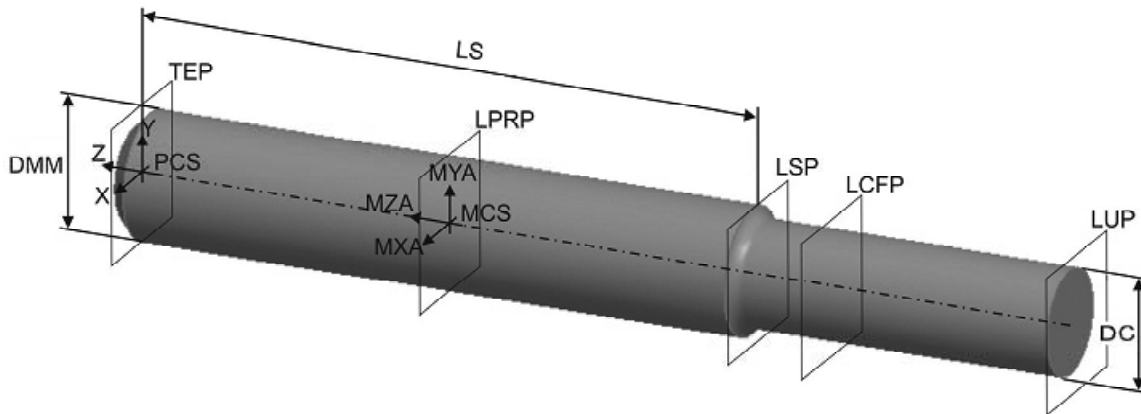

Figure 7 — Twist drill — Non-cutting part including the connection

5.4 Geometry of the cutting part

The geometry of the cutting part shall be designed as a sketch in the front view YZ plane of the PCS with reference to the CIP and the LUP.

The rotational axis is the standard Z-axis.

Design of the sketch:

- the sketch shall be determined as a half section; see [Figure 8](#);
- the tip angle shall be defined as the point angle “SIG” and recorded as this value;
- the sketch shall be constrained to the CIP, to planes PLP and LUP according to [Figures 8 and 9](#). If the CAD software does not support the use of datum planes, the sketch shall be fully dimensioned; otherwise, distances shall be in conjunction with the defined datum planes;
- Dimensioning shall be done with the appropriate properties listed in [Table 1](#).

The sketch shall be rotated about the Z-axis through 360°.

6 Step drill

6.1 General

Figure 11 shows the properties used for identification and classification of stepped drills.

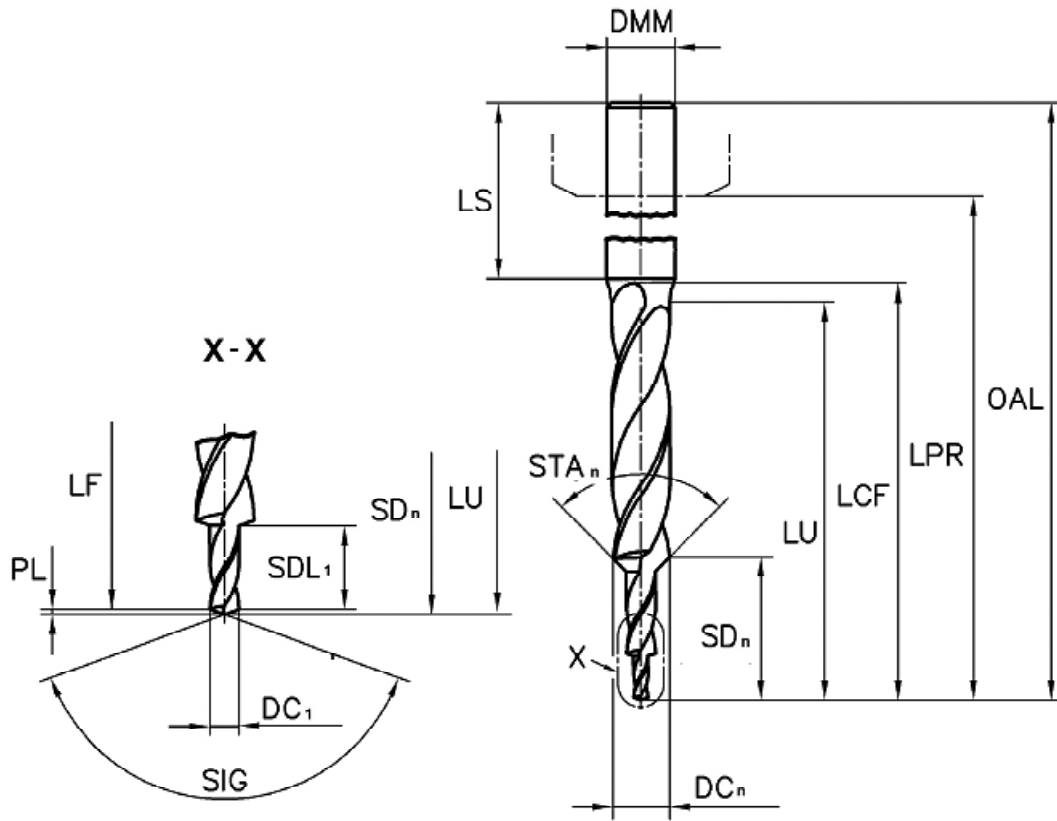

Figure 11 — Step drill — Determination of properties

6.2 Necessary properties

All necessary properties for the example of a step drill with three steps are listed in Table 3. The properties describing the appropriate cutting diameter shall be indexed by means of the ordinal number of the step. The ordinal number shall start with the cutting diameter closest to the workpiece, but excluding any plug chamfer diameter.

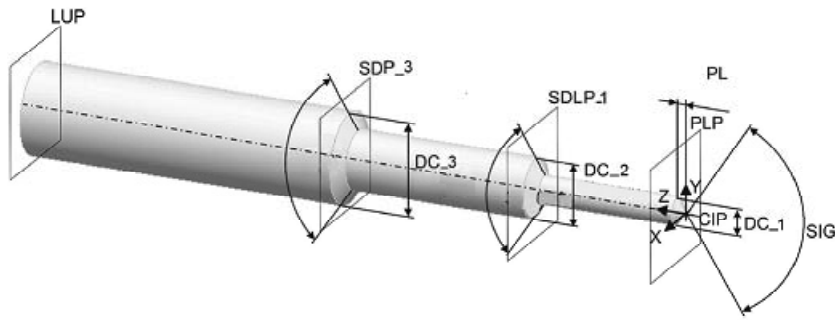

Figure 13 — Step drill — Revolved body of cutting part

6.5 Step drill — Complete

Figure 14 shows the complete step drill with cutting and non-cutting parts.

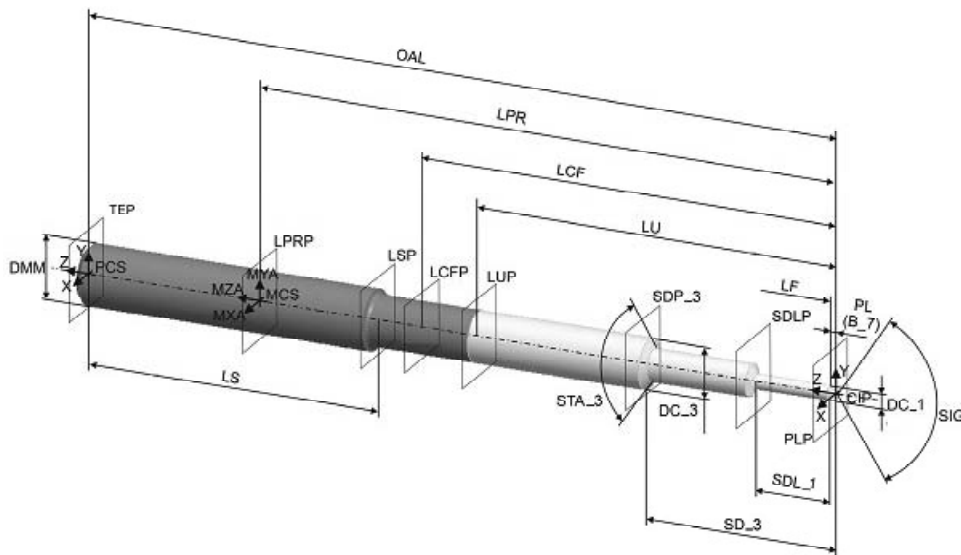

Figure 14 — Step drill — Complete

7 Core drill

7.1 General

Figure 15 shows the properties used for identification and classification of core drills.

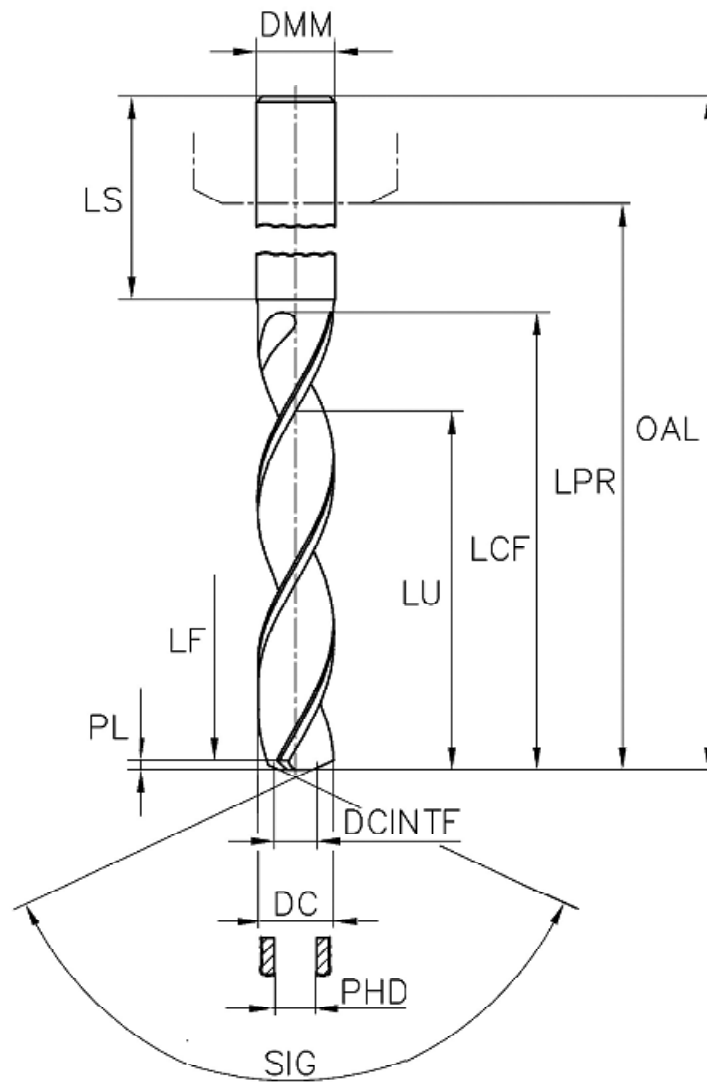

Figure 15 — Core drill — Determination of properties

7.2 Necessary properties

[Table 4](#) shows the properties needed for the modelling of a core drill.

Table 4 — Properties for the modelling of a core drill

Preferred name	Preferred symbol
cutting diameter	DC
interference cutting diameter	DCINTF
shank diameter	DMM
length chip flute	LCF
functional length	LF
protruding length	LPR
shank length	LS
usable length	LU
overall length	OAL
premachined hole diameter	PHD
point length	PL
point angle	SIG

7.3 Geometry of the non-cutting part including the connection

The structure of the model is described in 5.3 and is in accordance with Figure 7.

7.4 Geometry of the cutting part

The geometry of the cutting part is described in Figures 16 and 17.

The structure of the model is described in 5.4.

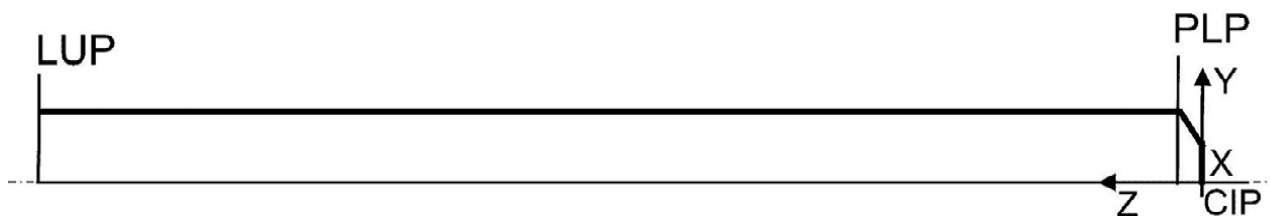

Figure 16 — Core drill — Sketch of cutting part

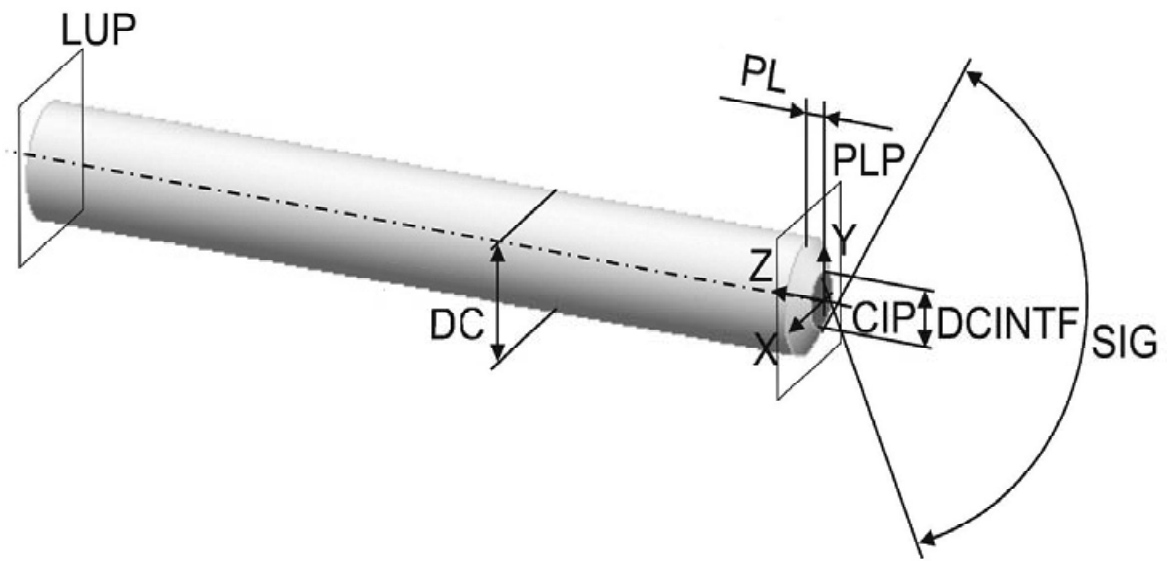

Figure 17 — Core drill — Revolved body of cutting part

7.5 Core drill — Complete

Figure 18 shows the complete core drill with cutting and non-cutting parts.

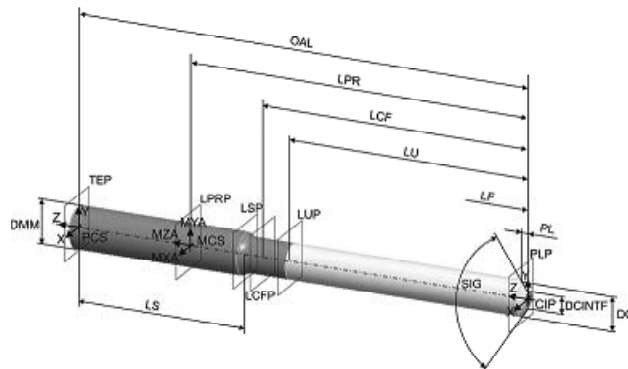

Figure 18 — Core drill — Complete

8 Counterbore

8.1 General

Figure 19 shows the properties used for identification and classification of counterboring tools.

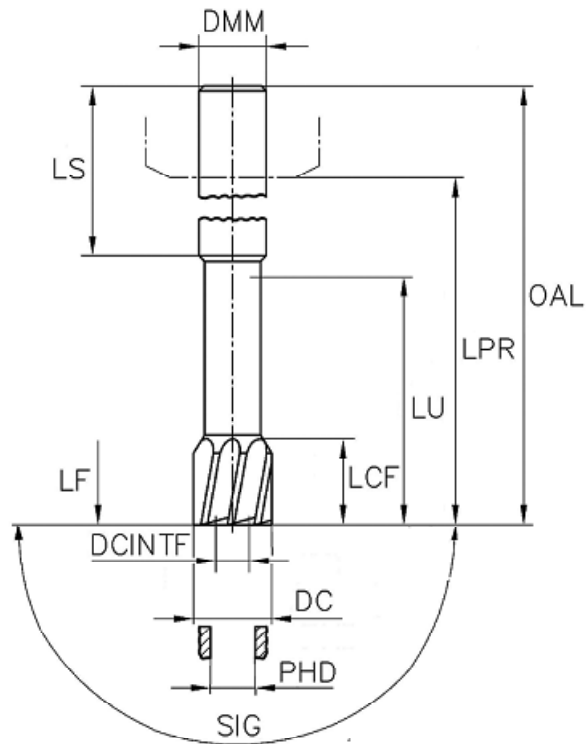

Figure 19 — Counterbore — Determination of properties

8.2 Necessary properties

[Table 4](#) gives the necessary properties.

8.3 Geometry of the non-cutting part including the connection

The structure of the model is described in [5.3](#) and is in accordance with [Figure 7](#).

8.4 Geometry of the cutting part

The geometry of the cutting part is illustrated in [Figures 20](#) and [21](#).

The structure of the model is described in [5.4](#).

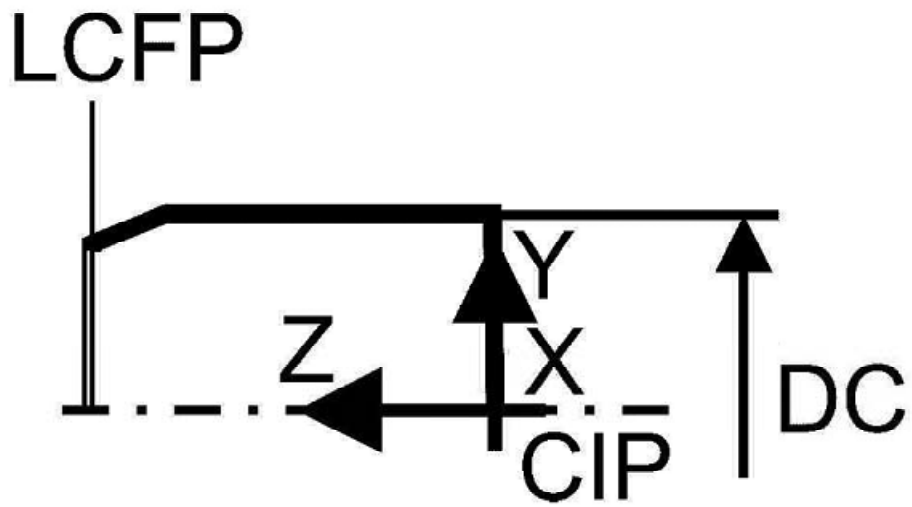

Figure 20 — Counterbore — Sketch of cutting part

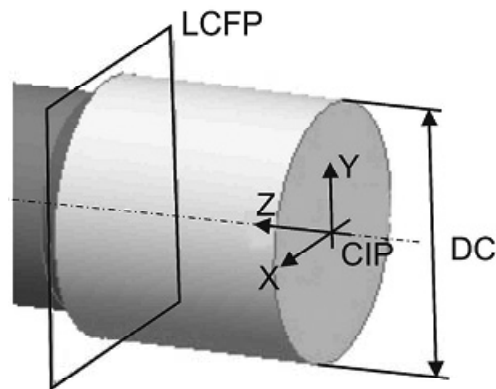

Figure 21 — Counterbore — Revolved body of cutting part

8.5 Counterbore — Complete

Figure 22 shows the complete counterbore with cutting and non-cutting parts.

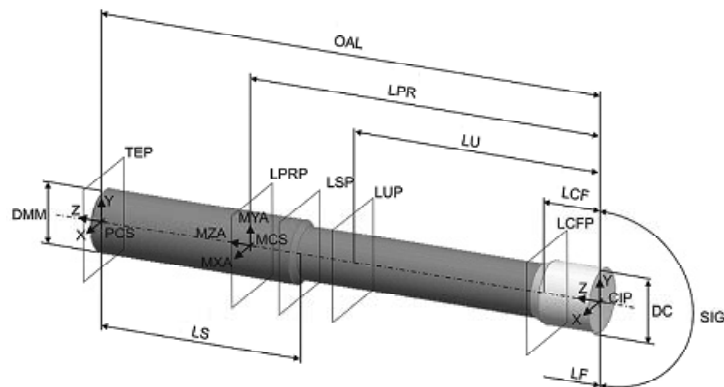

Figure 22 — Counterbore — Complete

9 Stepped countersinking tool or tapered countersinking tool

9.1 General

Figure 23 shows the properties used for identification and classification of stepped countersinking tools. Figure 24 shows the properties used for identification and classification of tapered countersinking tools.

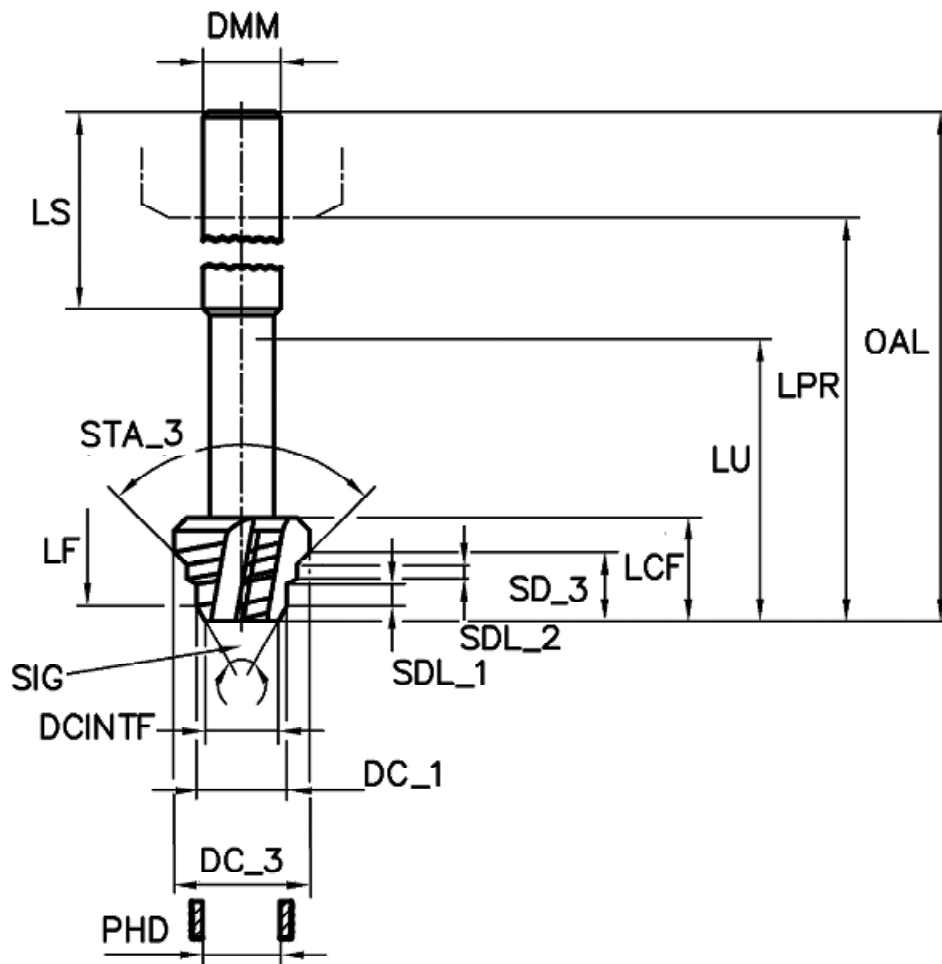
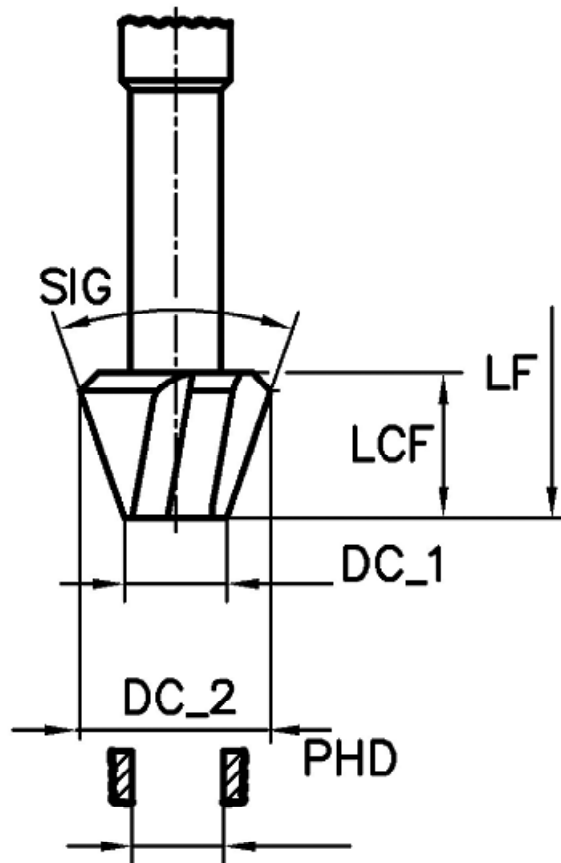

Figure 23 — Stepped countersinking tool — Determination of properties



Missing properties shall be taken from the stepped countersinking tool (see [Figure 23](#)).

Figure 24 — Tapered countersinking tool — Determination of properties

9.2 Necessary properties

All necessary properties for the example of a stepped countersinking tool with three steps or for tapered countersinking tool are listed in [Table 5](#). The properties describing the appropriate cutting diameter shall be indexed by means of the ordinal number of the step. The ordinal number shall start with the cutting diameter closest to the workpiece, but excluding any plug chamfer diameter.

Table 5 — Properties for the modelling of a stepped or tapered countersinking tool

Preferred name	Preferred symbol
cutting diameter, first cutting step	DC_1
cutting diameter, second cutting step	DC_2
cutting diameter, third cutting step	DC_3
interference cutting diameter	DCINT
premachined hole diameter	PHD
point length	PL
step diameter length, first cutting step	SDL_1
step diameter length, second cutting step	SDL_2
step distance length, second cutting step	SD_2
step distance length, third cutting step	SD_3

Table 5 (continued)

Preferred name	Preferred symbol
usable length	LU
functional length	LF
length chip flute	LCF
protruding length	LPR
overall length	OAL
point angle	SIG
step included angle, second cutting step	STA_2
step included angle, third cutting step	STA_3
shank diameter	DMM
shank length	LS

9.3 Geometry of the non-cutting part including the connection

The structure of the model is described in 5.3 and is in accordance with Figure 7.

9.4 Geometry of the cutting part

9.4.1 Cutting part of a stepped countersinking tool

The geometry of the cutting part of a stepped countersinking tool is illustrated in Figures 25 and 26.

The structure of the model is described in 5.4.

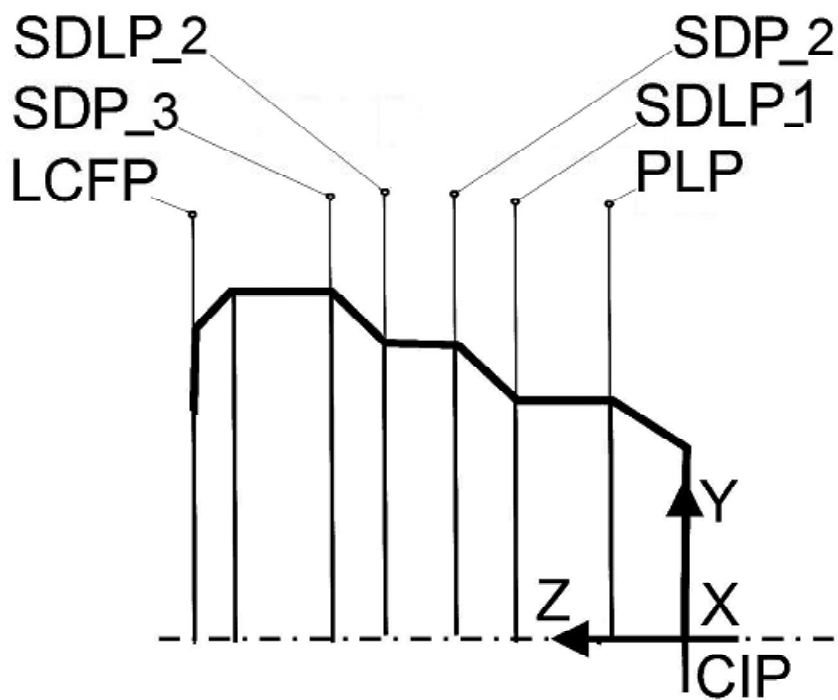

Figure 25 — Stepped countersinking tool — Sketch of cutting part

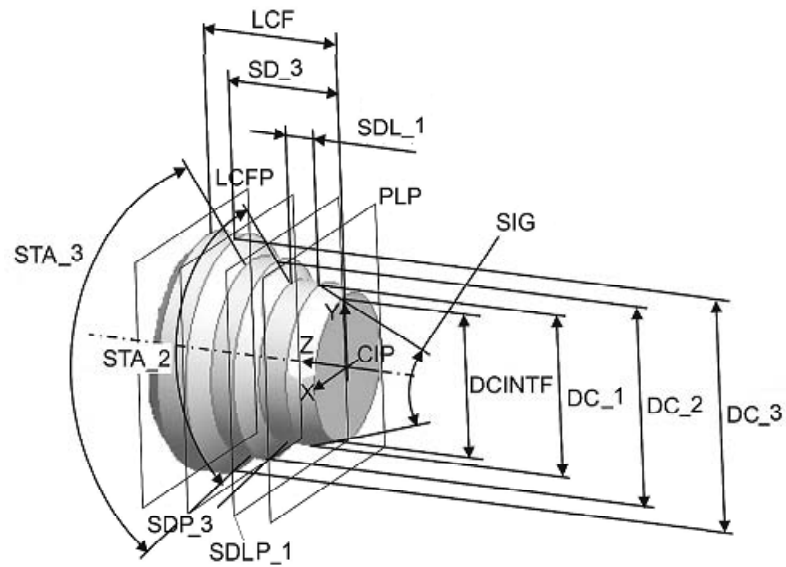

Figure 26 — Stepped countersinking tool — Revolved body of cutting part

9.4.2 Cutting part of a tapered countersinking tool

The geometry of the cutting part of a tapered countersinking tool is illustrated in [Figures 27](#) and [28](#). The structure of the model is described in [5.4](#).

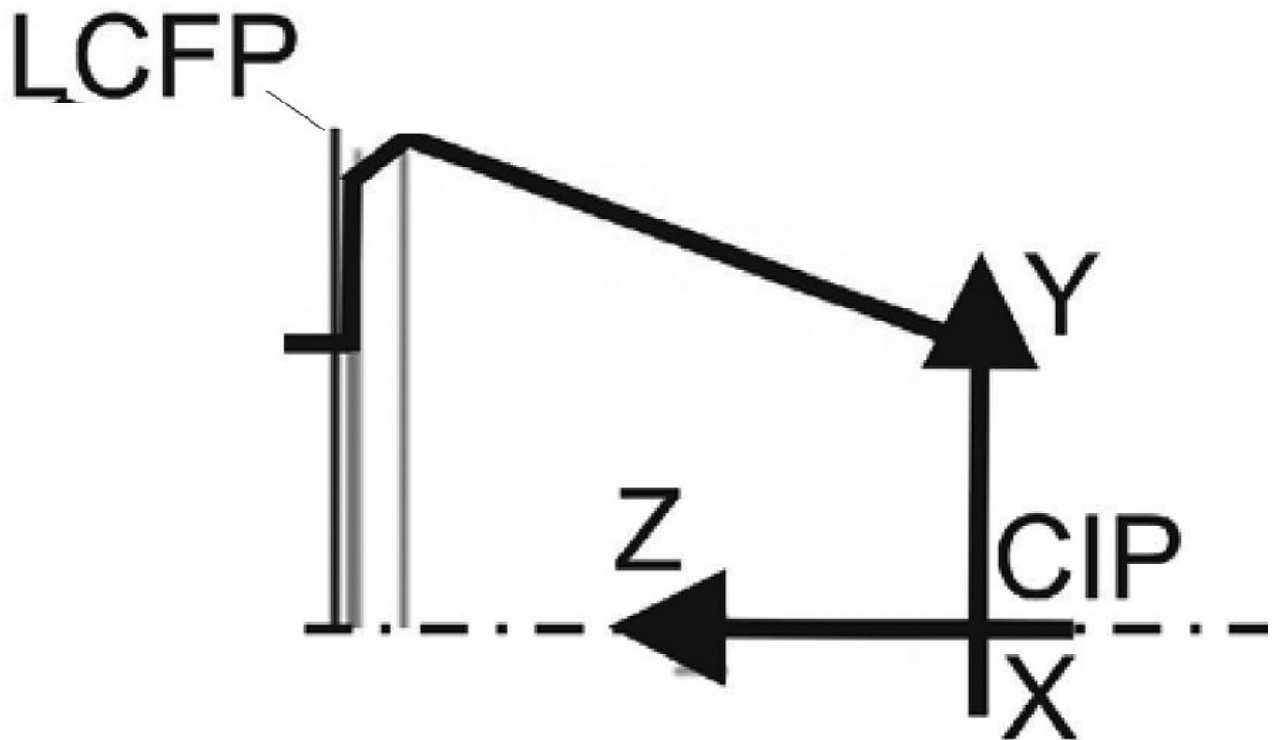

Figure 27 — Tapered countersinking tool — Sketch of cutting part

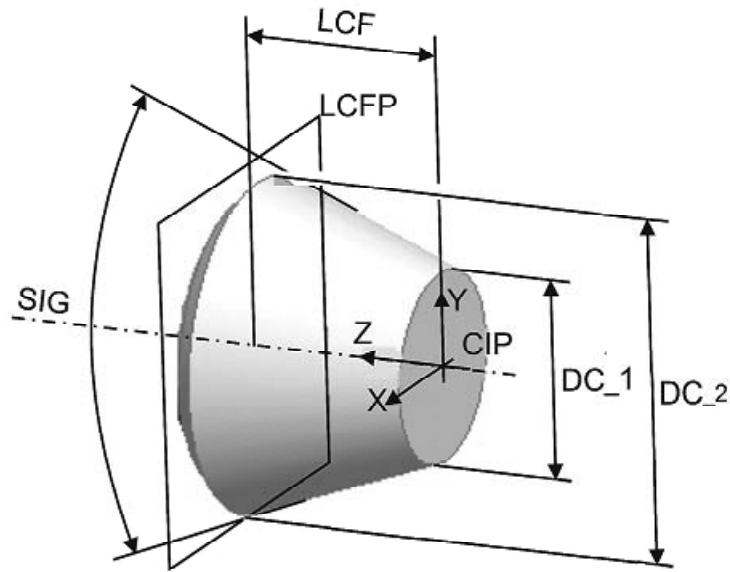

Figure 28 — Tapered countersinking tool — Revolved body of cutting part

9.5 Stepped or tapered countersinking tool — Complete

Figures 29 and 30 show the complete stepped countersinking and tapered countersinking tools with cutting and non-cutting parts.

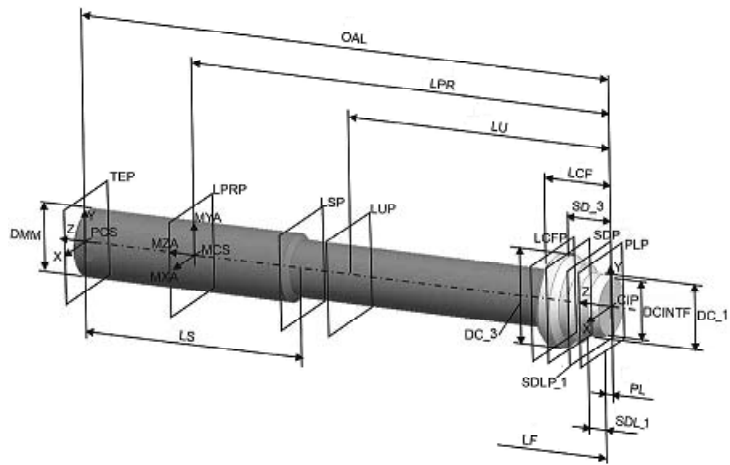

Figure 29 — Stepped countersinking tool — Complete

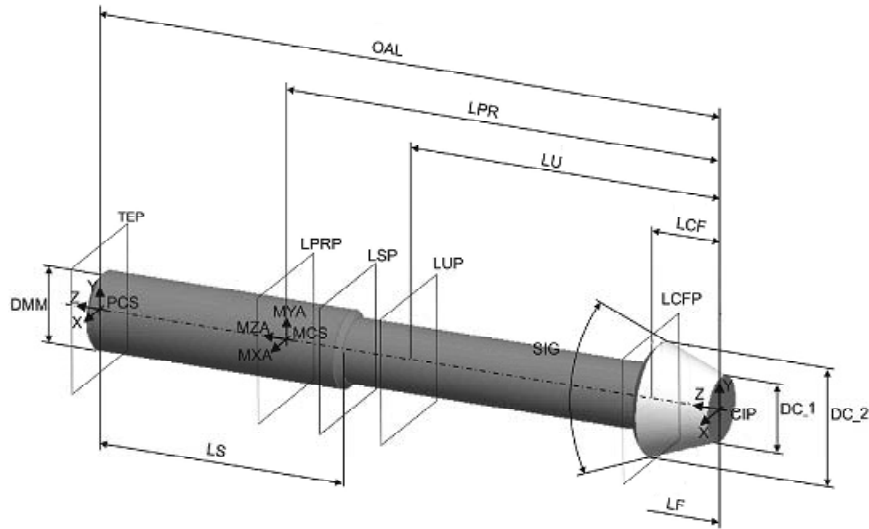

Figure 30 — Tapered countersinking tool — Complete

10 Spot drill

10.1 General

Figure 31 shows the properties used for identification and classification of spot drills.

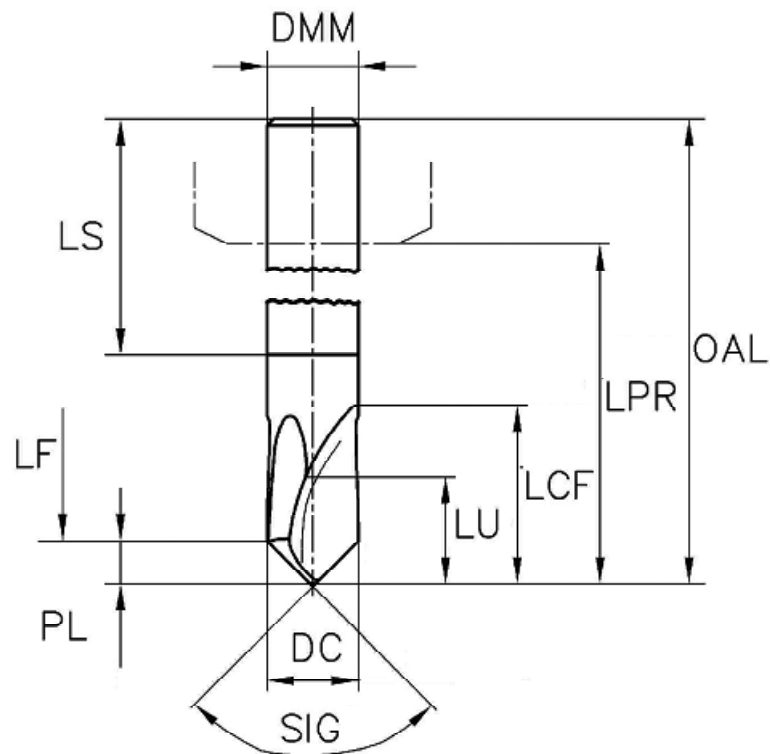

Figure 31 — Spot drill — Determination of properties

10.2 Necessary properties

Table 2 gives the necessary properties.

10.3 Geometry of the non-cutting part including the connection

The structure of the model is described in [5.3](#) and is in accordance with [Figure 7](#).

10.4 Geometry of the cutting part

The geometry of the cutting part of a spot drill is illustrated in [Figures 32](#) and [33](#).

The structure of the model is described in [5.4](#).

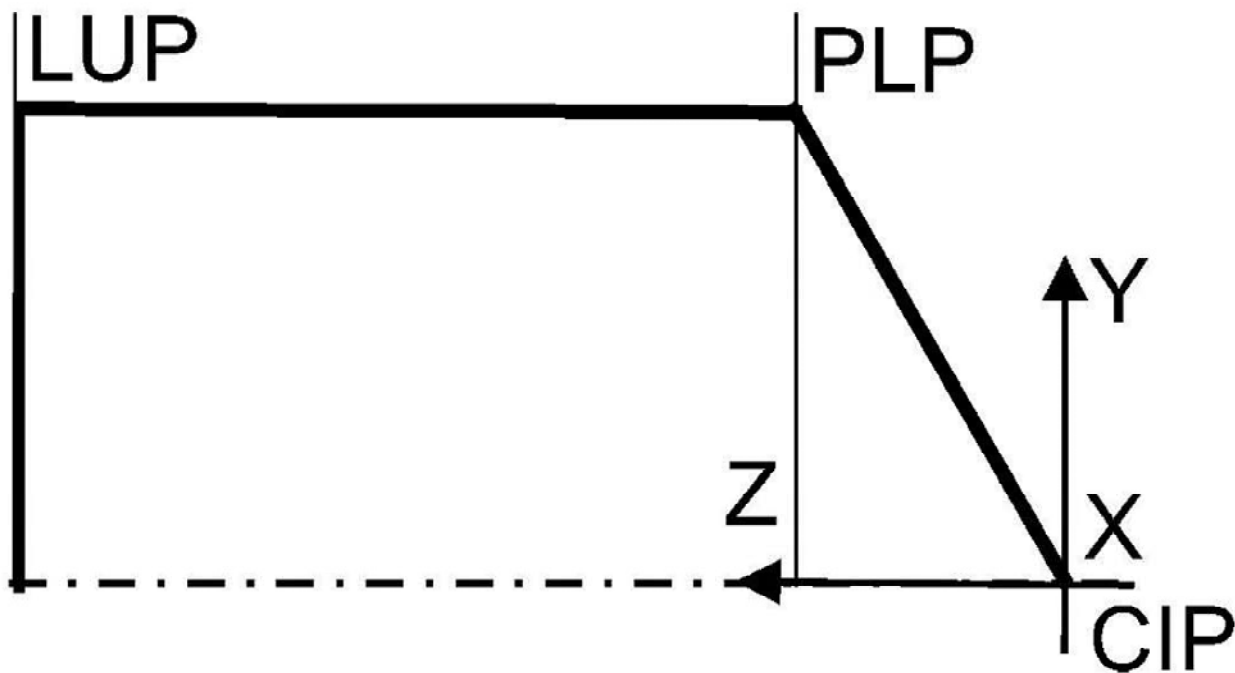

Figure 32 — Spot drill — Sketch of the cutting part

11.1.1 Centre drill for centre holes with radius form, style R

Figure 35 shows the properties used for identification and classification of style R centre drills.

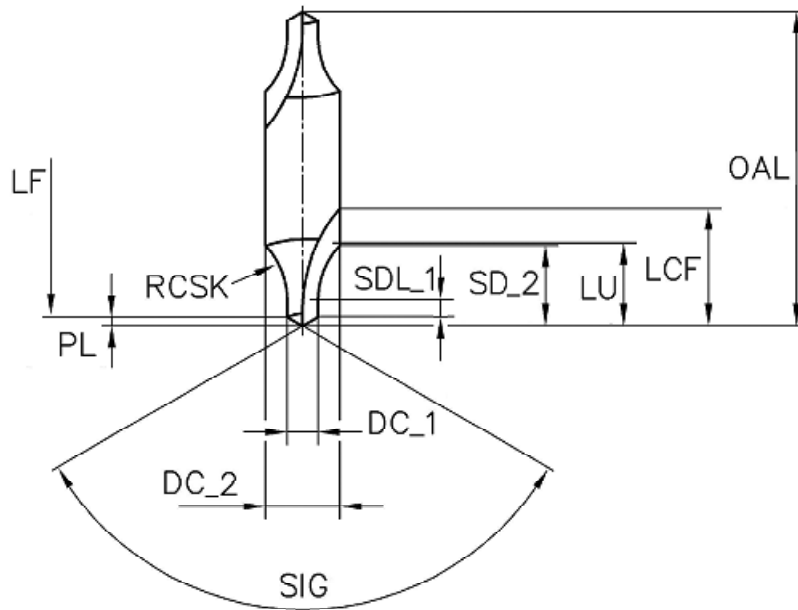

Figure 35 — Centre drill, style R — Determination of properties

11.1.2 Centre drill for centre holes without protection chamfers, style A

Figure 36 shows the properties used for identification and classification of style A centre drills.

Missing properties for the design shall be taken from Figure 35.

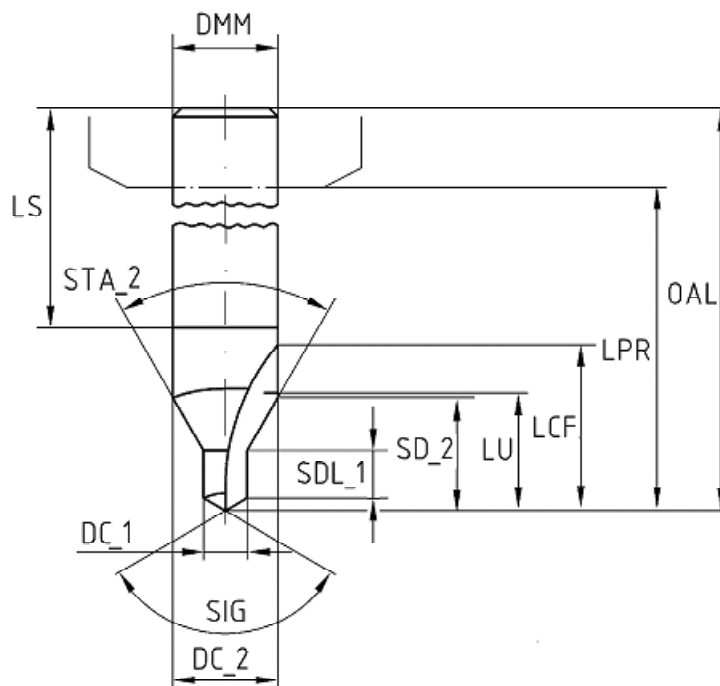

Figure 36 — Centre drill, style A — Determination of properties

11.1.3 Centre drill for centre holes with protection chamfers, style B

[Figure 37](#) shows the properties used for identification and classification of style B centre drills.

Missing properties for the design shall be taken from [Figure 35](#).

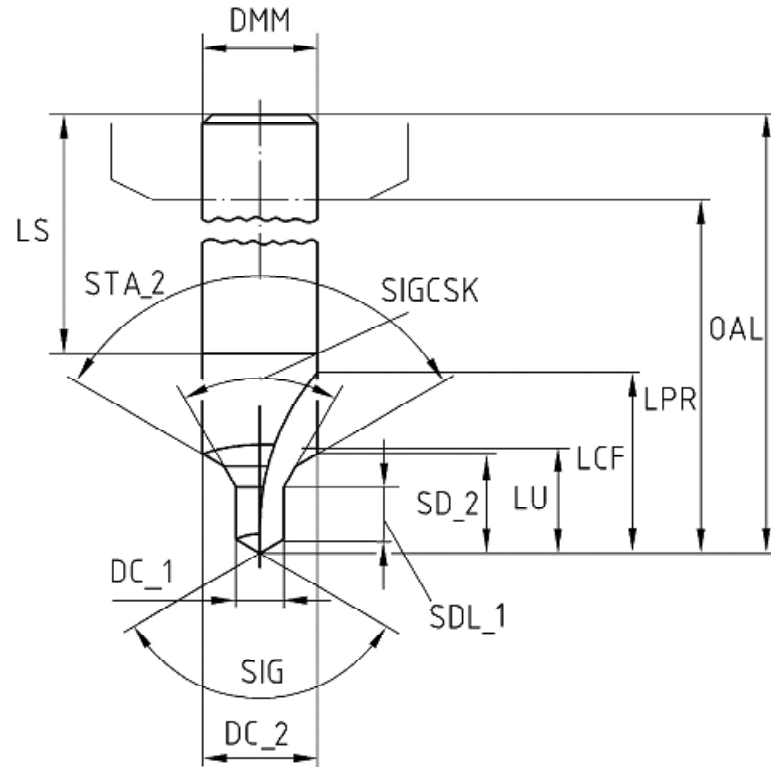

Figure 37 — Centre drill, style B — Determination of properties

11.2 Necessary properties

[Table 6](#) shows the properties needed for the modelling of a centre drill

Table 6 — Properties for the modelling of a centre drill — Style A, B or R

Preferred name	Preferred symbol
cutting diameter, first cutting step	DC_1
cutting diameter, second cutting step	DC_2
point length	PL
step diameter length, first cutting step	SDL_1
step distance length, second cutting step	SD_2
usable length	LU
length chip flute	LCF
protruding length	LPR
overall length	OAL
radius countersunk	RCSK
point angle	SIG
countersink angle	SIGCSK
step included angle, second cutting step	STA_2
shank diameter	DMM
shank length	LS
cutting end count	NCE

11.3 Geometry of the non-cutting part including the connection

The structure of the model is described in 5.3 and is in accordance with Figure 7. In the shank, if designed, the value of the “cutting end count” property shall be 1.

11.4 Geometry of the cutting part

The geometry of the cutting part of a centre drill is illustrated in Figures 38 and 39.

The structure of the model is described in 5.4.

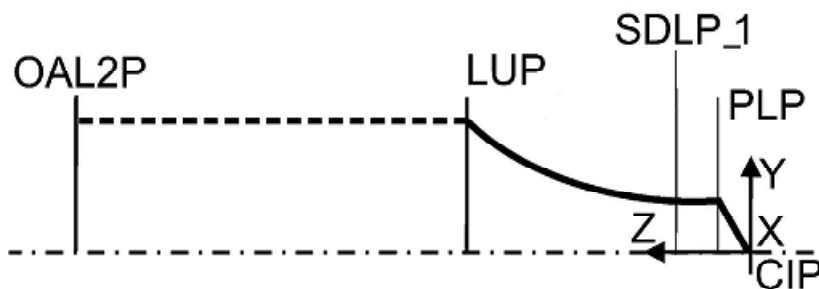

Figure 38 — Centre drill, style R — Sketch of the cutting part

If the value of the property “cutting end count” is 2, the plane OAL2P has the distance of OAL/2 from PCS. Starting at the CIP, only half of the sketch of the centre drill shall be designed. After generating the solid body by revolving the sketch around the tool axis, the body shall be copied and mirrored about the plane OAL2P.

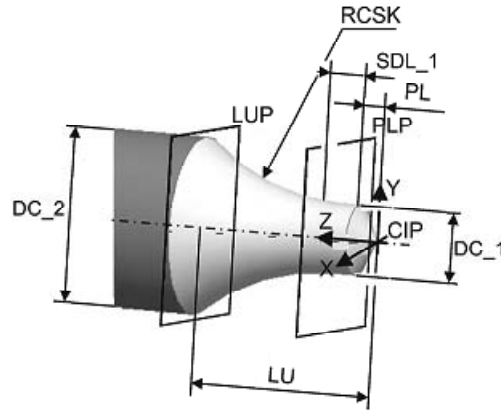

Figure 39 — Centre drill — Revolved body of cutting part

11.5 Centre drill — Complete

Figures 40 to 42 show the complete centre drills: style R (see Figure 40), style A (see Figure 41) and style B (see Figure 42) with cutting and non-cutting parts. Figures 41 and 42 show centre drills with one cutting end only and a shank feature.

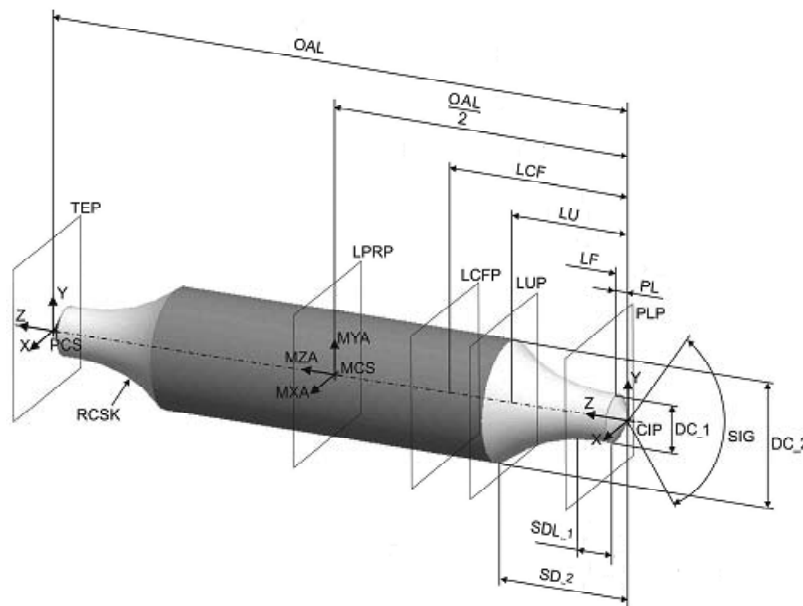

Figure 40 — Centre drill, style R — Complete

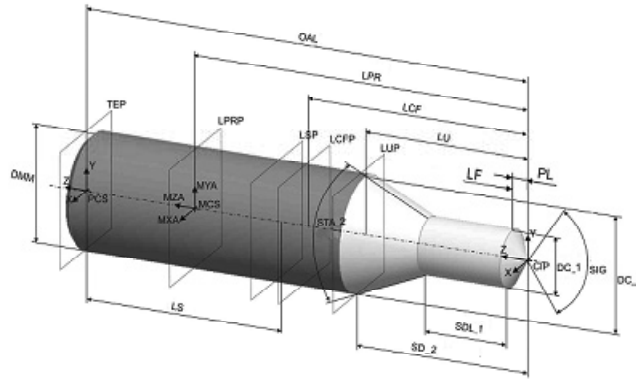

Figure 41 — Centre drill, style A — Complete

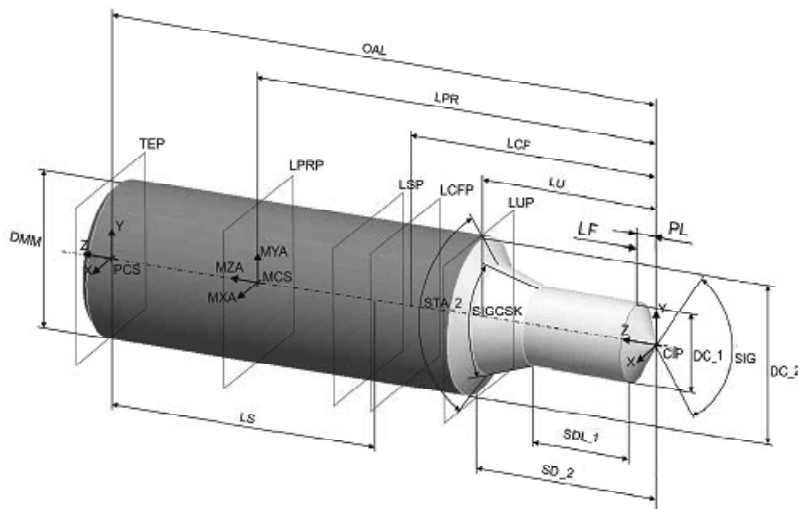

Figure 42 — Centre drill, style B — Complete

12 Shell core drills

12.1 General

Figure 43 shows the properties used for identification and classification of a shell core drill.

For improved, simplified design of shell core drill, the connection bore is designed as a cylindrical shape. The standard connection interface shall normally be a 1:30 taper.

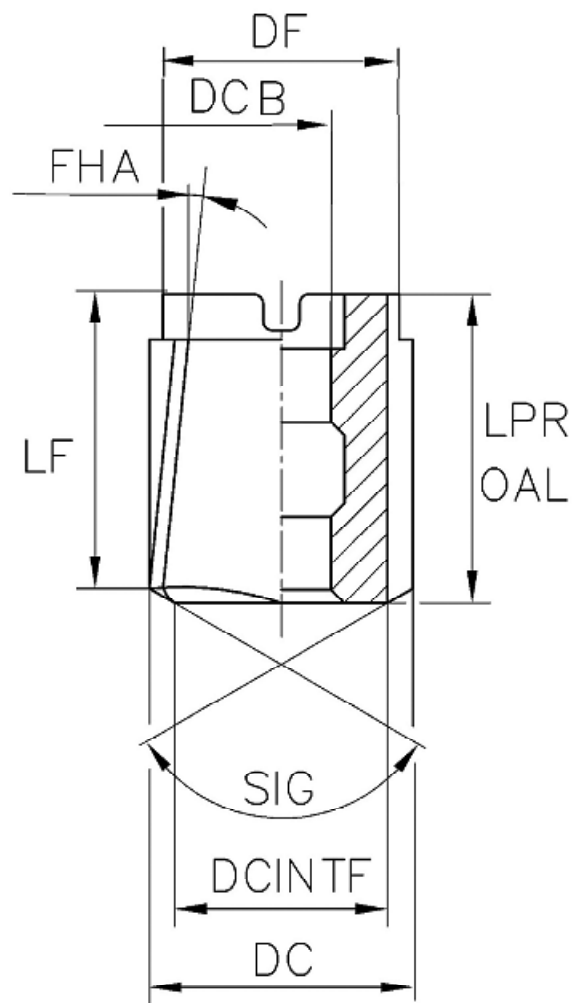

Figure 43 — Shell core drill — Determination of properties

12.2 Necessary properties

[Table 7](#) shows the properties needed for modelling a shell core drill.

Table 7 — Properties for modelling a shell core drill

Preferred name	Preferred symbol
cutting diameter	DC
interference cutting diameter	DCINT
flange diameter	DF
connection bore diameter	DCB
counterbore diameter connection bore	DCCB
premachined hole diameter	PHD
usable length	LU
functional length	LF
protruding length	LPR
overall length	OAL
point length	PL
counterbore depth of connection bore	LCCB
flute helix angle	FHA
point angle	SIG

12.3 Geometry of the non-cutting part

The connection bore shall be designed as a solid body to be subtracted from the tool body. It shall consist of any elements of the connection bore located between the PCS and the coordinate axis system in process CIP, which shall be the reference for the sketch that designed at the front view plane “YZP”.

The rotational axis is the standard Z-axis.

Design of the sketch:

- the sketch shall be determined as a half section;
- the sketch shall be constrained to the coordinate axis systems PCS and the CIP according to [Figure 44](#). If the CAD software does not support the use of datum planes, the sketch shall be fully dimensioned; otherwise, distances shall be in conjunction with the defined datum planes;
- Dimensioning shall be done with the appropriate properties listed in [Table 7](#).

The sketch shall be rotated about the Z-axis through 360°.

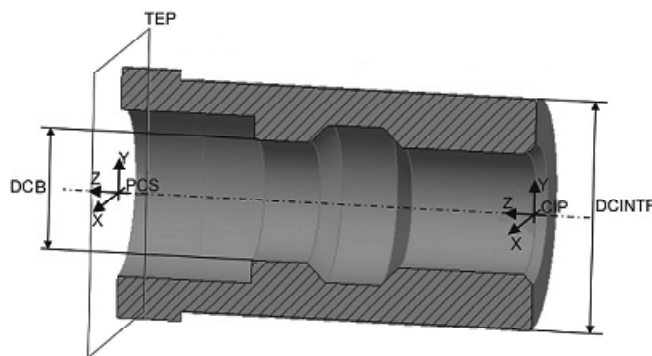

Figure 44 — Shell core drill: revolved connection — Inverse

12.4 Geometry of the cutting part

The geometry of the cutting part of a shell core drill is illustrated in [Figures 45](#) and [46](#).

The sketch used for the cutting part shall consist of a closed spline as shown in [Figure 45](#) and shall be placed on to the front view plane YZP.

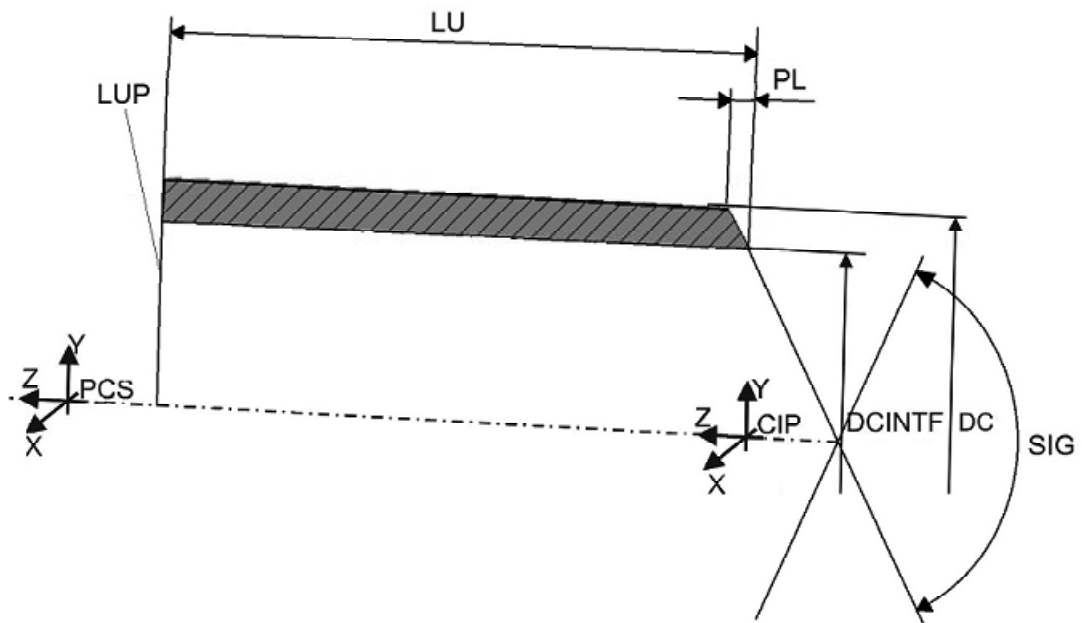

Figure 45 — Shell core drill — Sketch of cutting part

The sketch shall be constrained to the LUP datum plane and the CIP coordinate axis system.

The rotational axis is the standard Z-axis.

The structure of the model is described in [5.4](#).

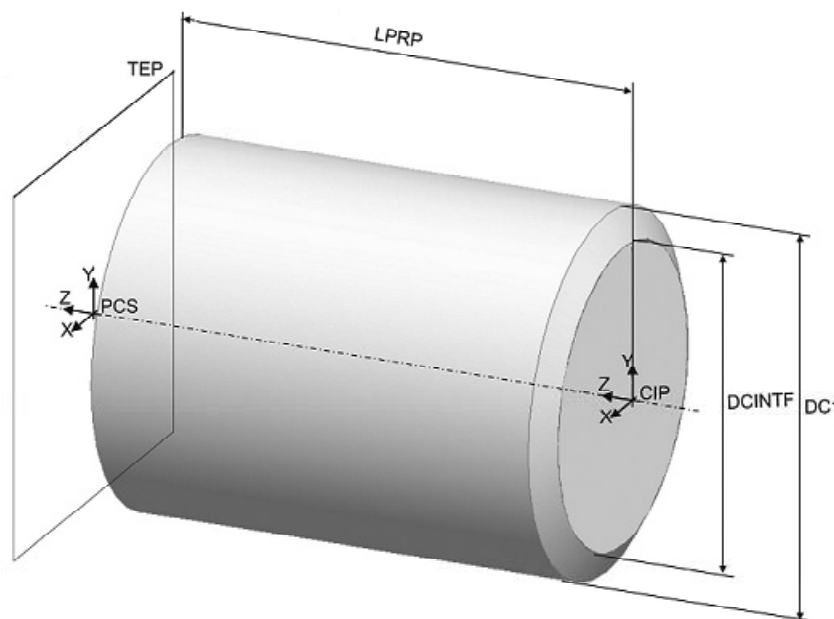

Figure 46 — Shell core drill — Revolved body of cutting part

12.5 Shell core drill — Complete

After the combination of the non-cutting and cutting parts and the subtraction of the connection bore from the non-cutting part, the complete shell core drill shall appear as shown in [Figure 47](#).

If it is necessary to show the tool with any kind of torque transmission, this feature shall be designed separately and incorporated accordingly.

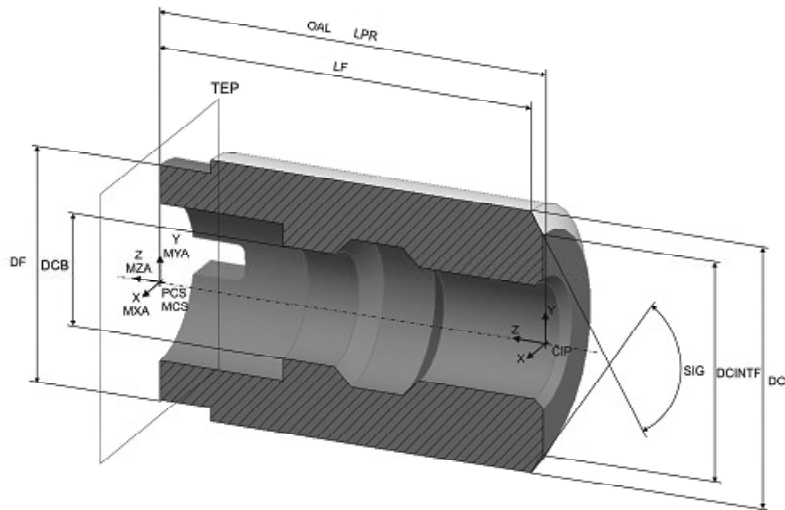

Figure 47 — Shell core drill — Complete

13 Shell counterbore

13.1 General

[Figure 48](#) shows the properties used for identification and classification of shell counterbores.

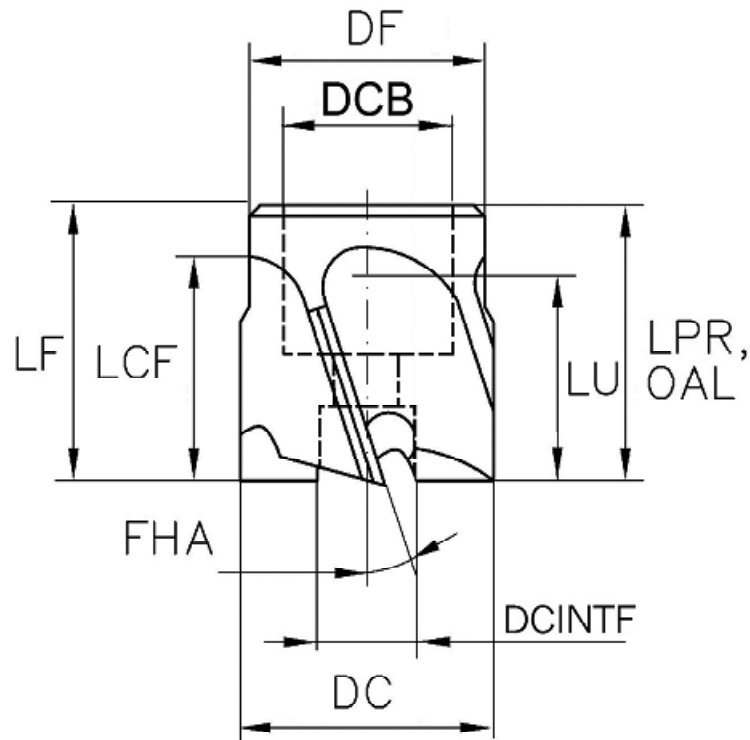

Figure 48 — Shell counterbore — Determination of properties

13.2 Necessary properties

[Table 7](#) gives the necessary properties.

13.3 Geometry of the non-cutting part

The structure of the model is described in [12.3](#) and is in accordance with [Figure 44](#).

13.4 Geometry of the cutting part

The structure of the model is described in [12.4](#) and is in accordance with [Figures 45](#) and [46](#).

13.5 Shell counterbore — Complete

After the combination of the non-cutting and cutting parts and the subtraction of the connection bore from the non-cutting part, the complete shell core drill shall appear as shown in [Figure 49](#).

If it is necessary to show the tool with any kind of torque transmission, this feature shall be designed separately and incorporated accordingly.

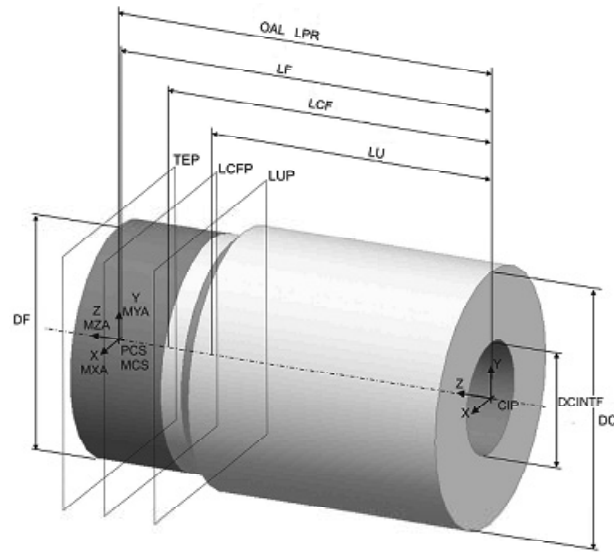

Figure 49 — Shell counterbore — Complete

14 Tapered shell countersinking tool

14.1 General

[Figure 50](#) shows the properties used for identification and classification of tapered shell countersinking tools.

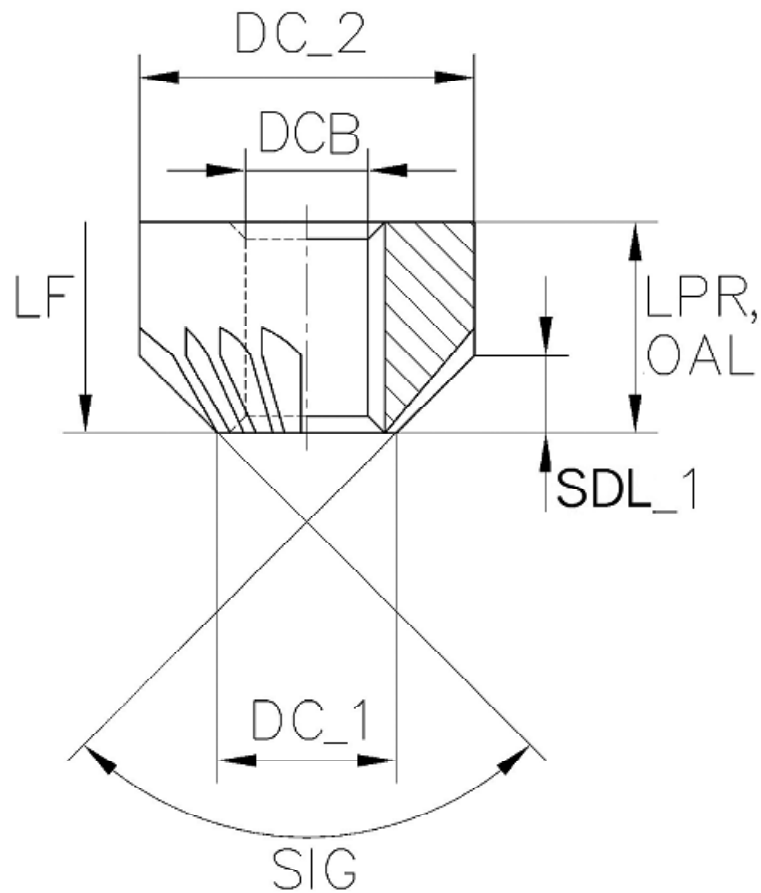

Figure 50 — Tapered shell countersinking tool — Determination of properties

The property SDL_2 shall be monitored because only it creates dimensions made redundant by the properties DC_1, DC_2 and SIG.

14.2 Necessary properties

All necessary properties are listed in [Table 8](#).

Table 8 — Properties for the modelling of a tapered shell countersinking tool

Preferred name	Preferred symbol
cutting diameter, first cutting step	DC_1
cutting diameter, second cutting step	DC_2
step diameter length, first cutting step	SDL_1
functional length	LF
protruding length	LPR
overall length	OAL
point angle	SIG
connection bore diameter	DCB

14.3 Geometry of the non-cutting part

The structure of the model is described in [12.3](#) and is in accordance with [Figure 44](#).

14.4 Geometry of the cutting part

The structure of the model is described in 12.4 and is in accordance with Figures 45 and 46.

14.5 Tapered shell countersinking tool

After the combination of the non-cutting and cutting parts and the subtraction of the connection bore from the non-cutting part, the complete shell core drill shall appear as shown in Figure 51.

If it is necessary to show the tool with any kind of torque transmission, this feature shall be designed separately and incorporated accordingly.

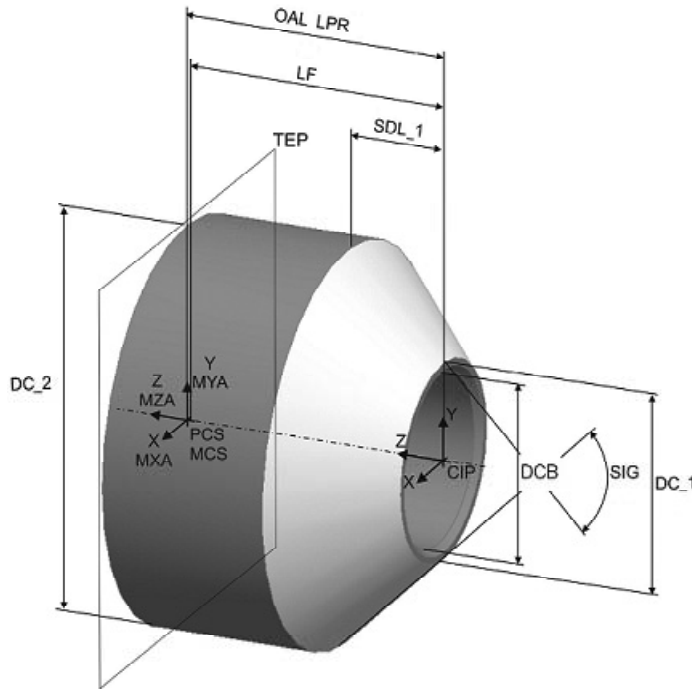

Figure 51 — Tapered shell countersinking tool — Complete

15 Stepped shell countersinking tool

15.1 General

Figure 52 shows the properties used for identification and classification of stepped shell countersinking tools.

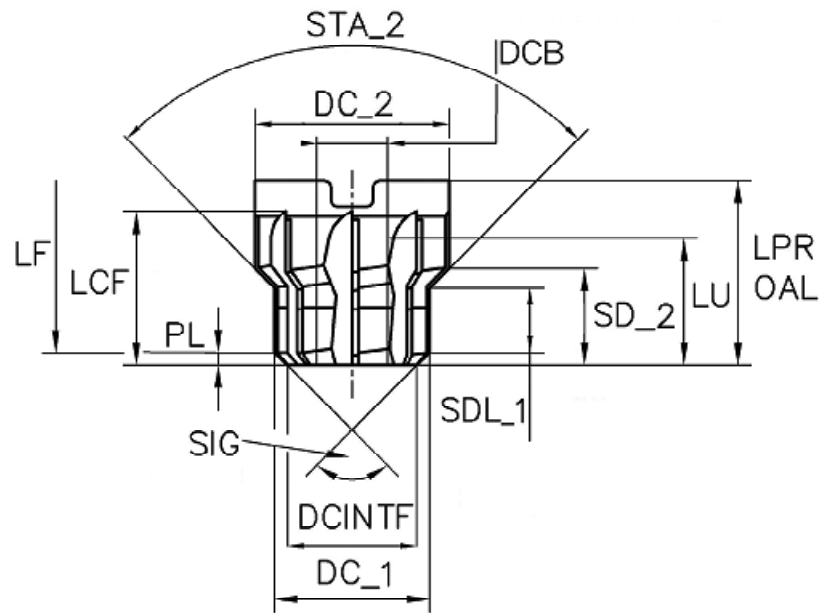

Figure 52 — Stepped shell countersinking tool — Determination of the properties

15.2 Necessary properties

All necessary properties for the example of a step drill with two steps are listed in [Table 9](#). The properties describing each cutting diameter shall be indexed by means of the ordinal number of the step. The ordinal number shall start with the cutting diameter closest to the workpiece, but excluding any plug chamfer diameter.

Table 9 — Properties for the modelling of a stepped shell countersinking tool

Preferred name	Preferred symbol
cutting diameter, first cutting step	DC_1
cutting diameter, second cutting step	DC_2
interference cutting diameter	DCINTF
point length	PL
step diameter length, first cutting step	SDL_1
step distance length, second cutting step	SD_2
usable length	LU
functional length	LF
length chip flute	LCF
protruding length	LPR
overall length	OAL
point angle	SIG
step included angle, second cutting step	STA_2
connection bore diameter	DCB

15.3 Geometry of the non-cutting part

The structure of the model is described in [12.3](#) and is in accordance with [Figure 44](#).

15.4 Geometry of the cutting part

The structure of the model is described in 12.4 and is in accordance with Figures 45 and 46.

15.5 Stepped shell countersinking tool complete

After the combination of the non-cutting and cutting parts and the subtraction of the connection bore from the non-cutting part, the complete shell core drill shall appear as shown in Figure 53.

If it is necessary to show the tool with any kind of torque transmission, this feature shall be designed separately and incorporated accordingly.

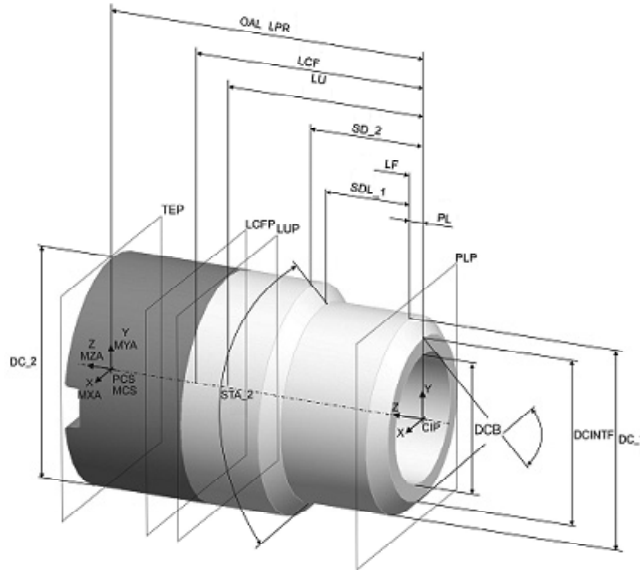

Figure 53 — Stepped shell countersinking tool

16 Modelling of guide pilots

16.1 General

Figure 54 shows the properties used for identification and classification of a guide pilot.

A guide pilot shall be designed either as a feature fixed to the tool or as an interchangeable component of an assembled tool. The guide pilot designed for an assembly shall only be used on the countersinking tool and/or core drill with a shank as connection interface.

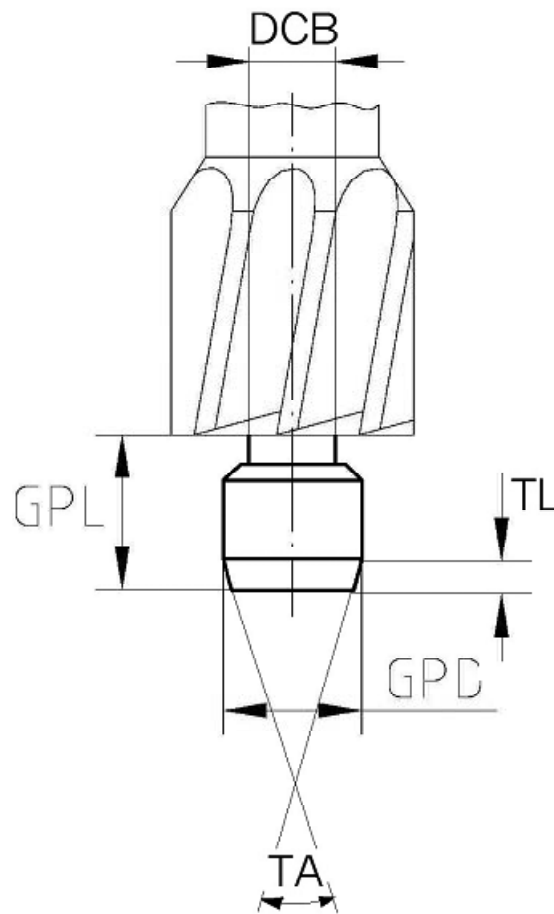

Figure 54 — Guide pilot — Determination of the properties

16.2 Necessary properties

All necessary properties are listed in [Table 10](#).

Table 10 — Properties for the modelling of a guide pilot

Preferred name	Preferred symbol
guide pilot diameter	GPD
guide pilot length	GPL
connection bore diameter	DCB
taper angle	TA
taper length	TL

16.3 Guide pilot

For visualization and attachment of a guide pilot to the cutting tool, it is sufficient to model only the visible part. It shall be constrained by the CIP coordinate axis system.

The following model of the guide pilot is sufficient and is illustrated in [Figure 55](#).

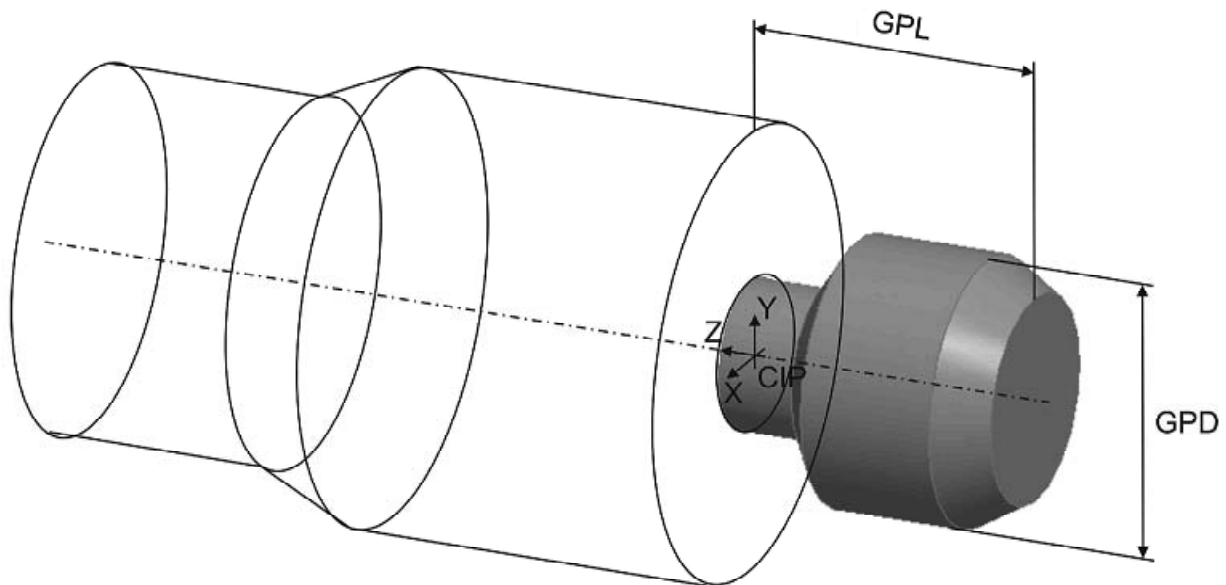

Figure 55 — Guide pilot — Attached to the cutting tool

17 Design of details

17.1 Basis for modelling

All details shall be designed as separate design features and shall not be incorporated into the revolved body of the crude geometry.

17.2 Contact/clamping surfaces — Orientation

Clamping surfaces that shall be visualized within the tool model shall be uniquely positioned. The normal of the face shall be parallel with the +Y-axis of the primary coordinate axis system PCS, as illustrated in [Figure 56](#).

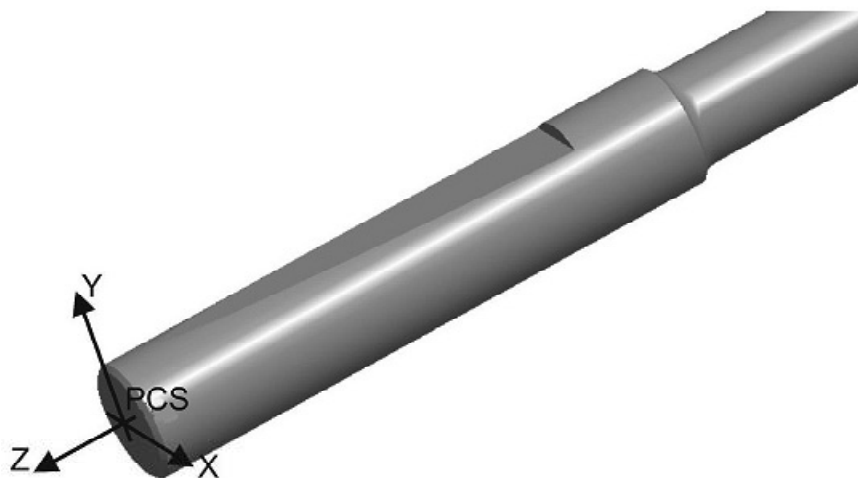

Figure 56 — Orientation of planar/clamping surfaces

17.3 Chamfers, roundings, others

Necessary chamfers and roundings shall be created according to the function of the 3D CAD system.

18 Attributes of surfaces — Visualization of model features

For a printed version of this part of ISO 13399 as well as for the 3D model itself, colour settings as part of the attributes of the surfaces should be in accordance with ISO/TS 13399-80.

NOTE 1 Some CAD systems identify only one surface of the same diameter even if these surfaces are mated by means of two solid design features. Therefore, to be able to address the surface attributes to each of these features a revolved design feature is created over the cutting part feature. In the tree of elements and features, this element is named “CUTTING_SURFACE”.

This design feature shall be created with the sketch elements of the cutting and non-cutting parts and is placed at the end of the tree.

NOTE 2 Some CAD systems make it possible to use the available lines of the main sketches for the creation of the “CUTTING_SURFACE”. Thus, the LCFP datum planes and any others are used as references. With the suppression of the main design elements, all referenced design elements may also be suppressed.

19 Structure of design elements (tree of model)

With drilling and countersinking tools, design feature “CUT” shall be distinguished from feature “NOCU”. This shall be ensured by means of building group. Thus, it is necessary that both groups may be suppressed or deactivated separately, without mutual interaction.

The detailed design features shall be put together in a separate group named “DETAILS”. This group shall be the last element of the tree. It is dependent on the “CUT” and “NOCUT” groups and shall be suppressed if either one of these two groups is suppressed (see [Figure 57](#)).

Such grouping shall be built only if the containing design features are arranged consecutively. Care shall be taken, therefore, to ensure correct sequencing of the design features, and avoid incorrect referencing.

The structure shall look similar to [Figure 57](#), using the example of a twist drill, and shall be similar to other CAD systems:

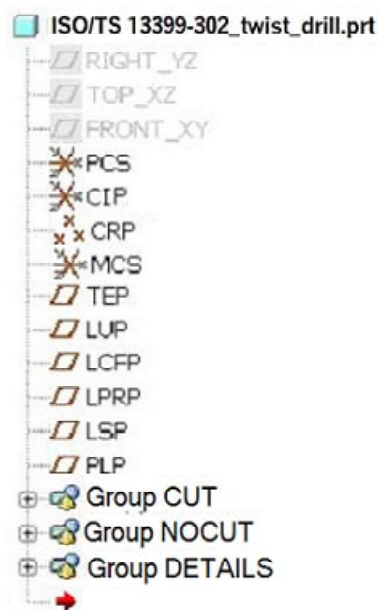
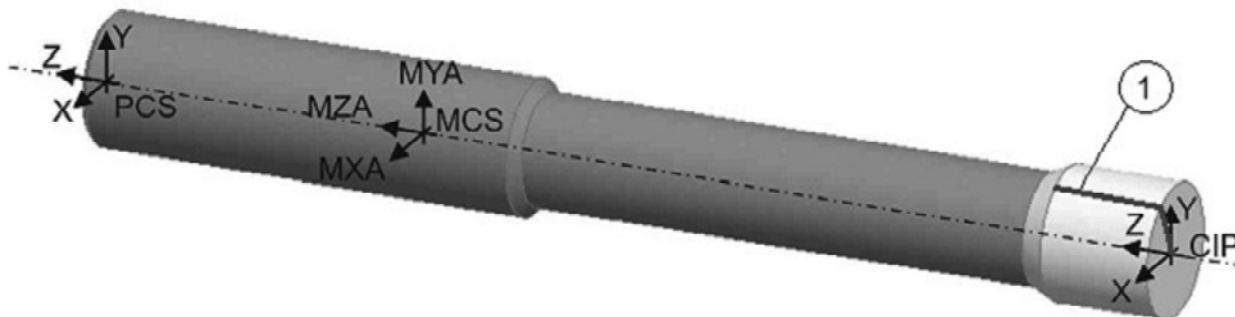

Figure 57 — Twist drill — Example of the structure of design features

20 Data exchange model

The model for data exchange is illustrated by [Figure 58](#) using the example of a thread-forming tap. All models shall contain the geometrical features (collision contour), primary coordinate axis system “PCS”, the MCS, the CIP and the cutting line, relevant for collision avoidance.



Key

1 cutting part line

Figure 58 — Data exchange model of a counterbore tool

Annex A (informative)

Information about nominal dimensions

A nominal dimension, nominal size or trade size is a size “in name only” used for identification. The nominal size may not match any dimension of the product, but within the domain of that product the nominal size may correspond to a large number of highly standardized dimensions and tolerances. A nominal size might not even carry any unit of measurement. A nominal value is often a value existing in name only, assigned as a convenient designation, rather than calculated by data analysis or following usual rounding methods. The use of nominal values can be based on *de facto* standards or some technical standards.

All real measurements have some variation depending on the accuracy and precision of the production method and the measurement uncertainty. The use of reported values often involves engineering tolerances. See [Table A.1](#).

Table A.1 — Examples of nominal dimensions/sizes

Description	Value	Tolerance	Lower limit	Upper limit	Nominal dimension/ size
Morse taper size 5	MT5	–	–	–	5
internal diameter	∅ 25	H6	25,000	25,013	25,000
external diameter	∅ 25	g7	24,972	24,993	25,000
square shank size hxb	32 × 25	h13	31,61 × 24,67	32 × 25	32 × 25

Bibliography

- [1] ISO 13584-24, *Industrial automation systems and integration — Parts library — Part 24: Logical resource: Logical model of supplier library*
- [2] ISO 13584-25, *Industrial automation systems and integration — Parts library — Part 25: Logical resource: Logical model of supplier library with aggregate values and explicit content*

