

---

---

**Road vehicles — Air filters for passenger  
compartments —**

**Part 1:  
Test for particulate filtration**

*Véhicules routiers — Filtres à air pour l'habitacle —  
Partie 1: Essai de filtration des particules*



Reference number  
ISO/TS 11155-1:2001(E)

© ISO 2001

**PDF disclaimer**

This PDF file may contain embedded typefaces. In accordance with Adobe's licensing policy, this file may be printed or viewed but shall not be edited unless the typefaces which are embedded are licensed to and installed on the computer performing the editing. In downloading this file, parties accept therein the responsibility of not infringing Adobe's licensing policy. The ISO Central Secretariat accepts no liability in this area.

Adobe is a trademark of Adobe Systems Incorporated.

Details of the software products used to create this PDF file can be found in the General Info relative to the file; the PDF-creation parameters were optimized for printing. Every care has been taken to ensure that the file is suitable for use by ISO member bodies. In the unlikely event that a problem relating to it is found, please inform the Central Secretariat at the address given below.

© ISO 2001

All rights reserved. Unless otherwise specified, no part of this publication may be reproduced or utilized in any form or by any means, electronic or mechanical, including photocopying and microfilm, without permission in writing from either ISO at the address below or ISO's member body in the country of the requester.

ISO copyright office  
Case postale 56 • CH-1211 Geneva 20  
Tel. + 41 22 749 01 11  
Fax + 41 22 749 09 47  
E-mail [copyright@iso.ch](mailto:copyright@iso.ch)  
Web [www.iso.ch](http://www.iso.ch)

Printed in Switzerland

# Contents

Page

<b>Foreword</b> .....	<b>iv</b>
<b>Introduction</b> .....	<b>v</b>
<b>1 Scope</b> .....	<b>1</b>
<b>2 Normative references</b> .....	<b>1</b>
<b>3 Terms and definitions</b> .....	<b>1</b>
<b>4 Test equipment, accuracy and validation</b> .....	<b>4</b>
<b>4.1 Measurement accuracy</b> .....	<b>4</b>
<b>4.2 Test system</b> .....	<b>4</b>
<b>4.3 Test conditions</b> .....	<b>9</b>
<b>4.4 Validation</b> .....	<b>9</b>
<b>4.5 Daily start-up procedures</b> .....	<b>10</b>
<b>5 Test methods</b> .....	<b>10</b>
<b>5.1 Performance test</b> .....	<b>10</b>
<b>5.2 Efficiency test</b> .....	<b>11</b>
<b>Annex A (normative) Test report</b> .....	<b>14</b>
<b>Annex B (normative) Efficiency data reduction</b> .....	<b>18</b>
<b>Annex C (normative) Pressure loss data reduction</b> .....	<b>24</b>
<b>Annex D (informative) Determination of maximum efficiency aerosol concentration</b> .....	<b>25</b>
<b>Annex E (normative) Check lists for accuracy requirements, validation and routine operation</b> .....	<b>26</b>
<b>Annex F (normative) Aerodynamic diameter</b> .....	<b>30</b>
<b>Annex G (normative) Methods for testing efficiency aerosol for proper neutralization</b> .....	<b>32</b>
<b>Bibliography</b> .....	<b>37</b>

## Foreword

ISO (the International Organization for Standardization) is a worldwide federation of national standards bodies (ISO member bodies). The work of preparing International Standards is normally carried out through ISO technical committees. Each member body interested in a subject for which a technical committee has been established has the right to be represented on that committee. International organizations, governmental and non-governmental, in liaison with ISO, also take part in the work. ISO collaborates closely with the International Electrotechnical Commission (IEC) on all matters of electrotechnical standardization.

International Standards are drafted in accordance with the rules given in the ISO/IEC Directives, Part 3.

The main task of technical committees is to prepare International Standards. Draft International Standards adopted by the technical committees are circulated to the member bodies for voting. Publication as an International Standard requires approval by at least 75 % of the member bodies casting a vote.

In other circumstances, particularly when there is an urgent market requirement for such documents, a technical committee may decide to publish other types of normative document:

- an ISO Publicly Available Specification (ISO/PAS) represents an agreement between technical experts in an ISO working group and is accepted for publication if it is approved by more than 50 % of the members of the parent committee casting a vote;
- an ISO Technical Specification (ISO/TS) represents an agreement between the members of a technical committee and is accepted for publication if it is approved by 2/3 of the members of the committee casting a vote.

An ISO/PAS or ISO/TS is reviewed after three years with a view to deciding whether it should be confirmed for a further three years, revised to become an International Standard, or withdrawn. In the case of a confirmed ISO/PAS or ISO/TS, it is reviewed again after six years at which time it has to be either transposed into an International Standard or withdrawn.

Attention is drawn to the possibility that some of the elements of this part of ISO/TS 11155 may be the subject of patent rights. ISO shall not be held responsible for identifying any or all such patent rights.

ISO/TS 11155-1 was prepared by Technical Committee ISO/TC 22, *Road vehicles*, Subcommittee SC 7, *Injection equipment and filters used on road vehicles*.

This first edition cancels and replaces the first edition of ISO/TR 11155-1:1994, of which it constitutes a technical revision.

ISO/TS 11155 consists of the following parts, under the general title *Road vehicles — Air filters for passenger compartments*:

- *Part 1: Test for particulate filtration*
- *Part 2: Test for gaseous filtration*

Annexes A, B, C, E, F and G form a normative part of this part of ISO/TS 11155. Annex D is for information only.

## Introduction

The following passenger compartment air filter test code has been established to cover particulate air filters and the particulate filter section in combined filters (particulate and gas filtration) used in automotive interior ventilation systems.

The objective of this procedure is to maintain a uniform test method for evaluating the filter performance characteristics of particulate air filters on specified laboratory test stands.

The performance characteristics of greatest interest are pressure loss (or airflow restriction), overall and fractional efficiencies, and holding capacity for airborne particles.

The data collected according to this test code can be used to establish performance characteristics for filters tested in this manner. The actual field operating conditions, including contaminants, humidity, temperature, mechanical vibration and flow pulsation are too difficult to duplicate.



# Road vehicles — Air filters for passenger compartments —

## Part 1: Test for particulate filtration

### 1 Scope

This part of ISO/TS 11155 specifies a particulate filtration test, including the critical characteristics of equipment, test procedure and report format, for the consistent assessment of filter elements in a laboratory test rig with particle sizes larger than 0,3 µm. It is applicable to filters for removing particulate matter from external or recirculated air used for ventilating motor vehicle passenger compartments or cabins.

The test specified in this part of ISO/TS 11155 enables an assessment of filter elements for pressure loss, fractional filtration efficiency and accelerated particulate holding capability against standardized laboratory particulate challenges. Because the test methods exclude the full range of possible particulate challenges and environmental effects, the relative ranking of filters may change in service.

NOTE 1 Absolute comparability is only possible with filter elements of the same shape and size as well as the same position in the test duct.

NOTE 2 Subject to agreement between supplier and the customer, the test procedure allows for the calculation of gravimetric efficiency as a single parameter for quality control purposes. For gravimetric efficiency tests refer to ISO 5011.

### 2 Normative references

The following normative documents contain provisions which, through reference in this text, constitute provisions of this part of ISO/TS 11155. For dated references, subsequent amendments to, or revisions of, any of these publications do not apply. However, parties to agreements based on this part of ISO/TS 11155 are encouraged to investigate the possibility of applying the most recent editions of the normative documents indicated below. For undated references, the latest edition of the normative document referred to applies. Members of ISO and IEC maintain registers of currently valid International Standards.

ISO 5011, *Inlet air cleaning equipment for internal combustion engines and compressors — Performance testing*

ISO 12103-1, *Road vehicles — Test dust for filter evaluation — Part 1: Arizona test dust*

ASTM F-328, *Practice for determining counting and sizing accuracy of an airborne particle counter using near-monodispersed spherical particulate materials*, Annual Book of ASTM Standards, Vol. 10.05, 1989

### 3 Terms and definitions

For the purposes of this part of ISO/TS 11155, the following terms and definitions apply.

#### 3.1

##### **test air flow rate**

volume of air passing through the test duct per unit time, expressed in actual cubic metres per hour (m<sup>3</sup>/h)

**3.2**

**pressure loss**

permanent pressure reduction due to a decrease in the flow energy (velocity head) caused by the filter (in pascals at standard conditions of 23 °C and 101,3 kPa)

**3.3**

**fractional efficiency**

$E_{fi}$

ability of the air filter to remove particles of a specified size, expressed as a percentage

**3.4**

**initial fractional efficiency**

fractional efficiency before the collected particles have any measurable effect on the efficiency of the filter under test

NOTE The collected particles can affect the measured filter efficiency before enough aerosol is collected to affect the filter pressure loss.

**3.5**

**fractional penetration**

$P_{fi}$

ratio of the concentration of particles of specified size exiting the filter to the concentration of particles of specified size entering the filter, expressed as a percentage

**3.6**

**test dust-holding capacity**

mass of test dust collected by the filter at the specified terminal pressure loss and flow rate, expressed in grams

**3.7**

**hydraulic diameter**

$D_h$

equivalent diameter used to characterize non-round ducts, calculated as:

$$D_h = 4 \times (\text{area of cross-flow section} / \text{duct perimeter})$$

**3.8**

**particle counter**

**aerosol spectrometer**

instrument for sizing or counting aerosol particles, or both

**3.9**

**test aerosol**

particles suspended in air, used for filter-efficiency or -capacity evaluation

**3.10**

**correlation ratio**

$R_o$

ratio of the number of particles observed at the downstream sampling location to the number of particles at the upstream sampling location when no filter is installed in the test

NOTE The method of calculating the correlation ratio is given in annex B.

**3.11**

**log mean diameter**

$D_{l,i}$

weighted mean diameter calculated by:

$$D_{l,i} = (D_i \times D_{i+1})^{1/2} \tag{1}$$



where

$D_{l,i}$  is the log mean diameter;

$D_i$  is the lower threshold size of the particle size range;

$D_{i+1}$  is the upper threshold size of the particle size range

### 3.12

#### **geometric (volume equivalent) diameter**

$D_{g,i}$

diameter of sphere with the same volume as the particle being measured

### 3.13

#### **optical (equivalent) diameter**

$D_{o,i}$

diameter of a particle of the type used to calibrate an optical sizing instrument that scatters the same amount of light as the particle being measured

NOTE Optical diameter depends on the instrument, the type of particle used to calibrate the instrument (usually polystyrene latex spheres), the optical properties of the particle being measured, and the size of the particle.

### 3.14

#### **aerodynamic (equivalent) diameter**

$D_{ae,i}$

diameter of a sphere of density 1 g/cm<sup>3</sup> with the same terminal velocity due to gravitational force in calm air, as the particle being measured

NOTE The aerodynamic diameter is used to report results to avoid different diameter measures due to different sizing and counting techniques. Annex F provides additional information about aerodynamic diameter.

### 3.15

#### **efficiency challenge aerosol**

aerosol used to measure the efficiency of a test filter

NOTE The concentration is low enough to prevent coincidence-related errors in the particle counters, and does not change the filter efficiency due to loading. The aerosol charge is reduced so that it approximates a Boltzman equilibrium charge distribution. The requirements for the efficiency challenge aerosol are given in 4.2.3 and 4.2.4.

### 3.16

#### **capacity challenge aerosol**

aerosol used to load the filter

NOTE The concentration is high enough to allow loading of the filter in a reasonable time, but may be too high to allow the use of typical particle counting instruments. The requirements for the capacity challenge aerosol are given in 4.2.3 and 4.2.4.

### 3.17

#### **neutralized aerosol**

aerosol whose charge distribution is reduced until it provides a Boltzman equilibrium charge distribution

NOTE 1 The aerosol is not neutral in the sense that all individual particles are neutral.

NOTE 2 It may not be possible to obtain a true Boltzman equilibrium charge distribution in the short time available in a test system. The procedures in annex G are designed to minimize the effect of excess charge arising from the aerosol generation method.

## 4 Test equipment, accuracy and validation

### 4.1 Measurement accuracy

Accuracy requirements are given in Table E.1 (4.1).

### 4.2 Test system

#### 4.2.1 System requirements

**4.2.1.1** The test stand shall consist of a conductive and grounded vertical test section (at least in its section between dust addition and the downstream sample probe) with test-filter mounting framework, and shall be designed to minimize particle loss. It shall include equipment or apparatus for air conditioning and supply, flow rate measurement, pressure-loss measurement, and aerosol introduction and sampling. A test stand which meets the requirements of Tables E.1 and E.2 is acceptable. An example of a plenum chamber style test system is shown in Figure 1.

Other designs, such as tapered ducts where the filter mounting section is the same cross section as the filter, might be acceptable. In all cases, any deviations shall be arranged between the tester and the requester.

Test stand performance shall meet the requirements of this clause and shall be validated as part of the overall test system (test stand and associated equipment) as described in 4.4. Validation information shall be recorded in a standard format and made available to requesters. System validation shall be performed at least once per year in accordance with Table E.3.

The uniformity of air flow in the test duct shall be measured with a calibrated anemometer at the centre of each of four equal-sized areas, and at the centre at a distance of not more than 5 cm above the empty filter holder. The variation in air flow velocity shall be no more than  $\pm 10\%$  from the mean flow velocity.

**4.2.1.2** Provisions should be made to maintain the temperature and humidity of the test air in accordance with 4.3.4. Prior to mixing with test aerosol, air should be cleaned to a level of less than 1 % of the challenge aerosol concentration at all particle sizes. Use of HEPA filtration is required (see 4.3.3). The system shall demonstrate the ability to maintain these conditions over the period of time required to complete a filter evaluation.

The system shall be tightly sealed such that the leak rate is less than 100 l/min when the pressure in the duct is 500 Pa above ambient for systems that are pressurized, or 500 Pa below ambient for systems that are normally below ambient pressure. This test is conducted according to the method referenced in Table E.3.

The system shall be capable of delivering the user-specified flow rate. Furthermore, it shall be capable of maintaining this flow rate for the duration of a test and in the face of an increasing differential pressure. This flow rate will be typically up to 680 m<sup>3</sup>/h, with filter pressure loss of up to 1 000 Pa. The minimum flow rate at which the system validation shall be carried out is 150 m<sup>3</sup>/h. The system may operate at either positive or negative pressure, provided it meets the requirements of 4.2.

**4.2.1.3** Flow rate shall be measured in accordance with 4.1 across the range of the flow rate as specified in 4.2.1.2. Flow rate-measurement devices may be certified out of the test duct, provided they are installed in exact accordance with the manufacturer's requirements. If no manufacturer's installation instructions are available or if the flow rate-measurement devices are not installed according to such instructions, the flow rate measurement device shall be calibrated in place in the test rig and be traceable, once removed, to a standard calibrating source.

**4.2.1.4** Pressure loss (differential pressure) across the test filter shall be measured with a differential pressure device connected to pressure taps in the test duct. These taps shall be located in sections which are straight-sided, have the same cross section as the section including the filter under test, and which are positioned not more than one duct diameter (hydraulic) upstream and downstream of the test filter. The pressure taps shall be of the static-pressure type and may be configured as in Figure 1, A and B.

The pressure-loss instrumentation shall be capable of measuring the full range of pressure loss expected for the test, plus 10 %. Accuracy of measurement over this range shall be in accordance with 4.1.

Dimensions in millimetres

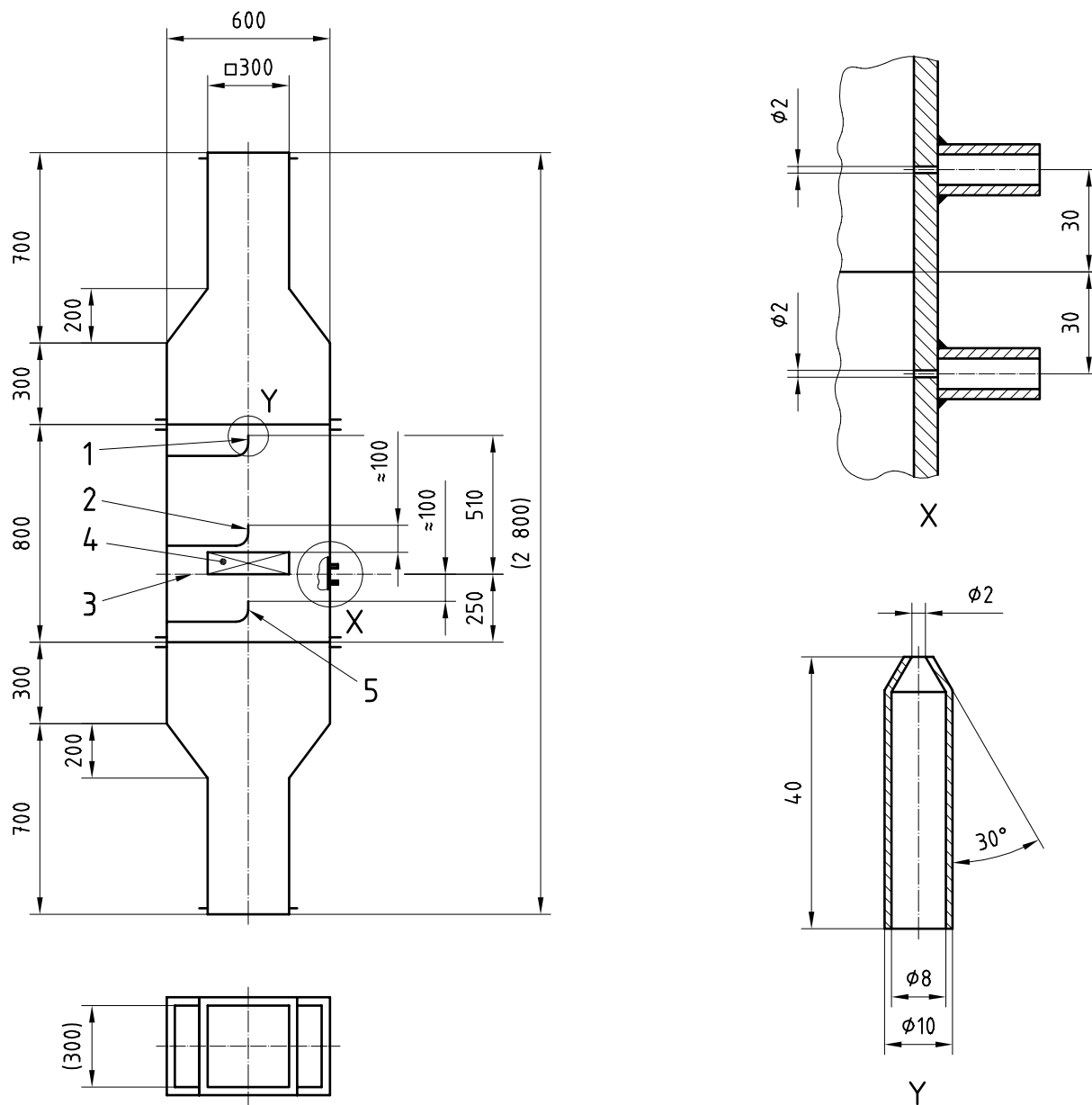

Details not indicated should be selected in accordance with the application.

**Key**

- |                                          |                 |
|------------------------------------------|-----------------|
| 1 Test dust feed                         | X Pressure taps |
| 2 Sampling probe upstream of test unit   | Y Feed nozzle   |
| 3 Test unit mounting plane               |                 |
| 4 Test unit                              |                 |
| 5 Sampling probe downstream of test unit |                 |

**Figure 1 — Example test duct**

**4.2.1.5** Aerosol shall be introduced into the duct and subsequently mixed in such a way that a uniform mixture of test aerosol will be delivered to the filter under test. In certifying the test system, the uniformity, concentration, and stability of the efficiency challenge aerosol shall be measured in accordance with 4.2.4.2. In addition, uniformity and concentration of the capacity challenge aerosol shall be verified in accordance with 4.2.4.3.

**4.2.1.6** The test filter shall be mounted in the horizontal position with the geometric centre of the filter coincident with the centre line of the duct. The test filter shall be sealed in a frame.

## **4.2.2 Sampling**

**4.2.2.1** The test aerosol shall be sampled upstream and downstream of the filter under test. The aerosol may be drawn through the sampling apparatus into a particle counter or other device. The performance of the sampling apparatus shall be evaluated as part of the test system in accordance with 4.2.4.2.

**4.2.2.2** Sampling probes shall be isokinetic (local velocity of duct and probe to be equal) to within  $\pm 20\%$ . The same probe design should be used before and after the filter. Sampling probes shall be located on the centre line of the test duct. The upstream probe shall be located at a distance of approximately 100 mm upstream from the filter under test. The downstream probe shall be located at least 75 mm downstream of an active area of the filter in the centre of duct and filter.

**4.2.2.3** Tubing leading to particle counters shall be as short as possible and minimize the number of bends and static build-up to avoid particle losses. The latter may be accomplished by using electrically conductive, grounded materials or choosing another material that has demonstrated good performance in this area. The use of valves and other restrictions should be avoided. If possible, the upstream and downstream sample lines should be identical.

## **4.2.3 Aerosol generator**

**4.2.3.1** An aerosol generator is used for fractional-efficiency tests. To measure the fractional efficiency either ISO 12103-1 A2 fine test dust or potassium chloride aerosol is used (see 4.2.3.2 or 4.2.3.3). Other aerosols can be used as specified by the requester. One should expect different results with different aerosols due to changes in the particle-counter response to particle refractive index, density, and shape. A calibration of the particle counter to the aerodynamic diameter of the test aerosol, or the use of a particle spectrometer directly measuring aerodynamic size will minimize the deviations when using different aerosols (see annex F).

Aerosol generators for fractional efficiency tests shall be capable of producing a stable aerosol concentration and size distribution. The size distribution of the aerosol shall have sufficient particles for statistical evaluation within each size class. Typically, this will be a minimum of 500 particles per size class per sample upstream; 100 particles per size class per sample downstream of the test filter are recommended. If high-resolution particle spectrometers are used, size classes may be combined to achieve the required counts using the size ranges in 4.2.5.1. The total concentration of the aerosol in the test duct shall not exceed the limit of the particle counter as discussed in 4.2.5.2. The efficiency challenge aerosol concentration shall be low enough so there is no change in efficiency during the test as described in 5.2.2 (i), i.e. no loading effects.

The aerosol concentration and size distribution shall be verified according to 4.2.4.2. The aerosol generator shall meet the performance requirements specified hereunder. The aerosol shall be charge-neutralized according to 4.2.6 prior to introduction into the test duct or within the test duct.

**4.2.3.2** The aerosol generator for fractional efficiency tests shall disperse ISO 12103-1 A2 fine test dust to produce a homogenous dust aerosol with stable concentration and size distribution.

**4.2.3.3** The potassium chloride aerosol generator for fractional efficiency tests shall nebulize a saline solution to produce a homogeneous mist aerosol with stable concentration and size distribution. The droplets shall be dried to form salt particles by using, for example, dry dilution air, heat or desiccant.

**4.2.3.4** A dust-feeding system consisting of a dust disperser and dust injector shall be used for dust-holding capacity and gravimetric efficiency tests. The dust feeder shall feed dust at a continuous and uniform rate, with a stable size distribution. The dust injector is used to disperse dust into the test system and shall not change the airborne particle size distribution. The dust-feeding system shall produce an aerosol of ISO 12103-1 A2 fine test

dust with a stable concentration ( $\pm 20$  % variation over time). The feed rate of the dust feeder shall produce a dust concentration in the test duct between  $50 \text{ mg/m}^3$  and  $100 \text{ mg/m}^3$ . The dust disperser and injection nozzle shall contain the ISO dust injector described in ISO 5011. The dust injector shall be operated at  $0,1 \text{ MPa}$  ( $1 \text{ bar}$ )<sup>1)</sup> air pressure. In case of the use of other injectors it shall be demonstrated that the injector in question performs at least as well as the ISO 5011 dust injector. The aerosol may be charge-neutralized according to 4.2.6 prior to challenging the filter under test.

The dust disperser can be open-tray or turntable Venturi-suction feeder, a rotary-brush feeder, a fluidized bed feeder, or other dust feeder capable of producing the required test dust.

#### 4.2.4 Aerosol challenge verification

**4.2.4.1** The uniformity, concentration, and stability of the test aerosol challenges (efficiency and capacity) shall be verified according to 4.2.4. This verification is done to assure that test filters receive a known and repeatable aerosol challenge. If tapered duct geometry is used, this verification shall be repeated for each test section.

Verification of the aerosol challenge takes into account performance of the aerosol generator, aerosol introduction and mixing method, sampling system, and aerosol-measurement devices.

**4.2.4.2** For verification of the efficiency challenge, the general procedures and requirements given in 4.2.3 should be followed.

For verification of uniformity and concentration of the efficiency challenge aerosol, no filter shall be installed in the location of the test filter. In the case of plenum chamber style test systems, the standard  $200 \text{ mm} \times 300 \text{ mm}$  orifice shall be used.

The uniformity of the particle size distribution and the concentration of the test aerosol used for efficiency tests shall be verified by use of a particle-sizing instrument that will also be used in the test system. This particle-sizing instrument shall draw samples upstream of the filter mounting position. Flow rate passing through the test stand shall be  $300 \text{ m}^3/\text{h}$ . Samples shall be drawn immediately in front of each of the four quadrants of the filter location and at the standard centre line sampling location. A minimum of five samples shall be drawn at each sampling location, and the resulting number distribution shall be averaged.

The average values for each reported particle-size range shall not vary by more than  $\pm 10$  % for  $0,3 \text{ }\mu\text{m}$  to  $5 \text{ }\mu\text{m}$  particles and  $\pm 20$  % for  $5 \text{ }\mu\text{m}$  to  $10 \text{ }\mu\text{m}$  particles among the five locations. This indicates that the challenge aerosol is uniformly distributed across the filter, and that the centre line sample is representative of the overall challenge.

Verification of the aerosol stability shall be combined with verification of the sampling apparatus used in efficiency testing. The stability of the aerosol challenge is evaluated over a period of time equivalent to an efficiency test. The sampling apparatus (including aerosol-measurement equipment) is evaluated for differences between upstream and downstream samples.

For verification of stability and sampling validity, no filter shall be installed in the location of the test filter. In the case of plenum chamber style test systems, the standard  $200 \text{ mm} \times 300 \text{ mm}$  orifice shall be used.

The method shall be as follows: The efficiency-test aerosol shall be sampled upstream and downstream of the test-filter location, with filter mounting framework in place, but with no test filter installed. All sampling apparatus shall be in place as described in 4.2.2.1. Samples shall be drawn isokinetically and performance shall be verified at  $300 \text{ m}^3/\text{h}$ .

Follow the sampling procedure specified in 5.2.2 (h). A total of three samples will be taken upstream and three samples downstream of the test-filter location. The count distribution (number of particles in each size class) shall be determined for each sample. The three upstream particle size distributions shall be compared and the numbers of particles measured in each size class should agree to within  $10$  % for  $0,3 \text{ }\mu\text{m}$  to  $5 \text{ }\mu\text{m}$  particles and  $\pm 20$  % for  $5 \text{ }\mu\text{m}$  to  $10 \text{ }\mu\text{m}$  particles among three particle size distributions. This criteria shall be applied to both the upstream, and the downstream particle size distribution.

1)  $1 \text{ bar} = 0,1 \text{ MPa} = 10^5 \text{ Pa}$ ;  $1 \text{ MPa} = 1 \text{ N/mm}^2$

The three upstream particle size distributions shall then be summed together by size class, likewise the three downstream particle size distributions. The result should be a total upstream and total downstream size distribution.

Use the information obtained in this section to create correlation ratios. This shall be done in accordance with annex B, and with agreement between tester and requester. The correlation ratio shall be between 0,7 and 1,6.

**4.2.4.3** For verification of the capacity challenge, the general procedures and requirements outlined in 4.2.3.1 and 4.2.3.4 should be followed.

The uniformity of particle size distribution of the test aerosol used for capacity tests (see 5.2.2) shall be verified by a gravimetric method. The method shall be as follows: A flat sheet of media (at least 99 % gravimetric efficiency on ISO 12103-1 A2 fine test dust) shall be weighed and installed in place of a test filter (in the standard 200 mm × 300 mm orifice in the case of plenum chamber style test systems). Flow shall be passed through the filter at 300 m<sup>3</sup>/h. The filter will be challenged with at least 12,5 mg of test dust per square centimetre of filter face area. At the completion of this loading step, the filter paper shall be removed from the test fixture and cut into four equal area parts. Each quadrant shall be weighed and the amount of aerosol captured by each quadrant determined. The weight of aerosol captured shall not vary by more than ± 10 % from quadrant to quadrant.

The particle size distribution of the capacity test aerosol is assured by the use of ISO 12103-1 A2 Fine test dust and an ISO 5011 Dust Injector. The mass concentration of the capacity challenge aerosol may be verified by weighing dust collected on a high efficiency filter in a measured time interval. The mass per unit volume (mass concentration in mg/m<sup>3</sup>) shall be calculated. The calculated mass concentration shall meet the requirements of 4.2.3.3.

The stability of the dust feed system shall be validated as follows.

- a) At 5 min intervals, determine the mass of dust dispensed. Continue mass determinations of dust increments for 30 min.
- b) Adjust the dust feeder until the average delivery rate is within ± 10 % of the desired rate and the deviation in delivery rate from the average is not more than ± 20 %.

#### **4.2.5 Airborne particles**

**4.2.5.1** The airborne particle concentration and size distribution upstream and downstream of the filter shall be measured by an airborne particle counter. The airborne-particle counter shall be capable of counting airborne particles used in the efficiency tests in the 0,3 µm to 10 µm geometric or 0,5 µm to 15 µm aerodynamic diameter range, divided into at least five particle size channels. The suggested standard size class thresholds are 0,3 µm, 0,5 µm, 1,0 µm, 2,0 µm, 5,0 µm and 10,0 µm geometric or 0,5 µm, 1,0 µm, 2,0 µm, 5,0 µm, 10,0 µm and 15,0 µm aerodynamic. For example, the suggested geometric size ranges are 0,3 µm to 0,5 µm, 0,5 µm to 1,0 µm, 1,0 µm to 2,0 µm, 2,0 µm to 5,0 µm, and 5,0 µm to 10,0 µm. The particle counter shall be calibrated for particle size over the specified range using polystyrene latex spheres. The polystyrene latex spheres shall be [e.g. National Institute of Standards and Technology (NIST)] traceable.

The airborne-particle counters shall be calibrated with polystyrene latex particles prior to system start-up and a minimum of once a year to verify that the size calibration has not changed. It is recommended that the particle counter calibration be verified with one size polystyrene latex periodically during the year between calibrations. If the counter shows an unacceptable change in the calibration, the counter should be serviced.

**4.2.5.2** The maximum total particle concentration shall be established to prevent coincidence counting, i.e. counting more than one particle at a time. A recommended method for establishing this limit is to conduct filter-efficiency tests at a series of different concentrations and compare the results. The maximum concentration is determined at the point where increasing the concentration by a factor of 2 causes the fractional efficiency in the smallest size range at the higher concentration to be more than 5 % less than the fractional efficiency at the lower concentration.

Another method is to increase the concentration stepwise (e.g. by using a diluted and an undiluted aerosol) and determine the concentration where the particle counter starts showing significant deviation from the expected concentration in the smallest size range.

An example is given in annex D.

**4.2.5.3** The particle counter flow rate shall remain constant within  $\pm 5\%$  for the duration of a test including the correlation done before the test.

#### 4.2.6 Neutralization

Generated and dispersed particles often develop a high level of electrical charge. To obtain comparable results for different aerosols and different generation methods, the aerosol's charge distribution shall be reduced until it provides a Boltzman equilibrium charge distribution. A Boltzman equilibrium charge distribution is the minimum stable charge level and is reached by an aerosol when aged. This state of an aerosol can not be generated artificially in a comparably short time. For many applications (e.g. filter testing), it is sufficient to reduce the charges, utilizing ionized air, to a minimum level. To reach this charge level quickly in a test system, the efficiency aerosol is mixed with a high concentration of air ions. To create a high level of air ions, an electrostatic corona (ion blower) or radioactive air ionizer shall be used. The ionizer shall produce a sufficient concentration of bipolar air ions to mix with the aerosol so that the resulting aerosol has a charge distribution that approximates a Boltzman distribution.

The level of neutralization shall be optimized by methods described in annex G.

Aerosol may become charged in transport through the tubing and test duct, so the neutralization should take place as close as practical to the filter under test.

A neutralizer is required for fractional-efficiency tests and is optional for dust-holding capacity tests.

#### 4.2.7 Air flow meter calibration

The air flow meter shall be calibrated annually in accordance with 4.1, using a flow measurement method conforming to the allowed tolerances.

#### 4.2.8 Repeatability

The organization performing tests in accordance with this test code shall demonstrate by identical tests performed on the same filter on three separate days of no less than three days apart that the pressure loss and initial filter efficiency for measured particle sizes  $0,3\ \mu\text{m}$  to  $5\ \mu\text{m}$  are in agreement with each other within  $\pm 5\%$ . Initial filter efficiency for  $5\ \mu\text{m}$  to  $10\ \mu\text{m}$  should agree within  $\pm 10\%$ . These tests do not include loading the filter.

### 4.3 Test conditions

**4.3.1** The test dust for dust-holding capacity and gravimetric efficiency shall be ISO 12103-1 A2 fine.

Before a test, the test dust shall be mixed for a minimum of 15 min. This test dust shall be dried to a constant mass at a temperature of  $105\ \text{°C} \pm 15\ \text{°C}$ . The test dust shall then be allowed to become acclimatized to a constant mass under the prevailing test conditions (see 4.3.4).

**4.3.2** Special aerosols such as mono- or polydisperse latex or lycopodium and other aerosols may be used for tests performed on the filter per user request.

**4.3.3** A high-efficiency particulate air filter (HEPA) type filter is used to clean air provided to the test stand. Maximum penetration for this filter shall be  $\leq$  to  $0,03\%$  for  $0,3\ \mu\text{m}$  particles. A high-efficiency filter is used downstream of the downstream sample location to protect the rest of the test system from dust.

NOTE This downstream filter is not necessarily the absolute filter used for gravimetric efficiency tests as per ISO 5011.

**4.3.4** All tests shall be conducted with air entering the air filter at a temperature of  $23\ \text{°C} \pm 5\ \text{°C}$  and a relative humidity of  $55\% \pm 15\%$ .

### 4.4 Validation

Prior to testing filters, the test stand shall be validated as per Table E.2.

The validation certifying the performance of a system in accordance with this test code shall be documented to include the following:

- a) system diagram and detailed description, including
  - 1) particle generator used,
  - 2) particle materials used in the tests including traceability,
  - 3) manufacturer and model of the particle counters, and
  - 4) calibration data for the particle counter(s);
- b) calibration data for flow rate;
- c) calibration data for pressure loss;
- d) system performance on flow uniformity;
- e) system performance on particle-concentration uniformity;
- f) data demonstrating that the coincidence-counting error meets the criteria of Table E.2;
- g) data showing the agreement between upstream and downstream particle counters for a single- or dual-counter system;
- h) data showing that the efficiency test aerosol concentration is low enough so that loading effects are avoided during the initial efficiency test;
- i) data showing that the aerosol neutralizer is working properly as per annex G;
- j) sample test data;
- k) sample test data showing the repeatability of test results.

Upon initial calibration and validation of the system, the initial efficiency of several mechanical filters and several electret filters as described in clause G.3 should be carefully measured. These filters become references that can be used for monitoring.

### 4.5 Daily start-up procedures

Each day, prior to testing filters, certain start-up procedures shall be performed to verify the continued proper operation of the test system. Such procedures include but are not limited to: verification of particle counter operation such as flow rate and zero count; measurement of background particle count in the test duct with no test filter, and no test aerosol (a high efficiency filter may be mounted in the test filter holder to check the downstream counter zero); correlation of upstream and downstream particle sampling and counting systems; check zero on pressure measurement device. See, for example, Table E.3. The reference filters can be used for daily checks of system performance.

## 5 Test methods

### 5.1 Performance test

#### 5.1.1 Air filter conditioning

Prior to the test, the filter shall be stabilized to temperature and humidity test conditions for at least 15 min.

#### 5.1.2 Pressure loss

The purpose of this test is to determine the pressure loss in dust-free air of a clean air filter.



- a) Measure and record the tare-static pressure loss with no filter in the test stand. Measure at nominal flow rates of 25 %, 50 %, 75 % and 100 % of the specified maximum air-filter flow rate.
- b) Mount the filter to be tested in the test stand. Measure and record the static-pressure loss versus nominal flow rate at, 25 %, 50 %, 75 % and 100 % of the specified maximum air-filter flow rate.
- c) Subtract the tare-pressure loss values from the measured filter pressure loss. Correct the measured pressure loss per annex C and graph in the test report (see annex A).

## 5.2 Efficiency test

### 5.2.1 General

The purpose of this test is to determine the particulate collection capabilities of the filter. This test is conducted with constant air flow rate using the aerosol described in 4.2.3.2 or 4.2.3.3.

The following types of efficiency test can be performed.

- a) Dust-holding capacity is determined when the specified terminal pressure loss ( $\Delta P_d$ ) is reached at rated flow. This test is done with ISO 12103-1 A2 fine test dust.
- b) The initial fractional efficiency as a function of particle size is determined for a clean filter for the five classes given in 4.2.5 and may be determined for other particle sizes. This test is done with potassium chloride or ISO 12103-1 A2 fine test dust.
- c) The incremental fractional efficiency as a function of particle size is determined at 10 %, 25 %, 50 % and 100 % of filter life ( $\Delta L$ ). This test is done with dust per 4.2.3.1 or potassium chloride aerosol described in 4.2.3.2. The incremental fractional efficiency is determined at the specified flow rate. The incremental life is determined by pressure loss across the filter as the filter is loaded with ISO 12103-1 A2 fine test dust. The filter pressure loss ( $\Delta P_i$ ) are calculated from: the initial pressure loss ( $\Delta P_o$ ), the fraction of filter life ( $\Delta L_i$ ), and the terminal pressure loss ( $\Delta P_d$ ). See Equation 6.

$$\Delta P_i = \Delta P_o + \Delta L_i (\Delta P_d - \Delta P_o) \quad (2)$$

The incremental fractional efficiency should be determined for at least the five classes of particle sizes specified in b).

### 5.2.2 Procedure

- a) Measure temperature and relative humidity.
- b) Without a filter in the test stand, set the specified volume flow rate and measure the tare pressure loss.
- c) Mount the filter in the test stand.
- d) Condition a new filter per 5.1.1.
- e) Set the specified volume air flow rate.
- f) Measure pressure loss.
- g) Start feeding the efficiency test aerosol (as specified in 4.2.3.2 or 4.2.3.3) and wait for the upstream aerosol to become stable.
- h) Determine the fractional efficiencies by particle counting as follows.
  - For sequential counting systems, start with the counter connected to the upstream sample probe; wait for the sampling system to equilibrate; the upstream particles should then be counted. Switch to the downstream sample probe; wait for the sampling system to equilibrate; the downstream sample should

then be counted. The upstream-downstream cycle should be repeated twice more for a total of three upstream and three downstream samples. Calculate the filter efficiency for each of the three samples.

- For simultaneous counting systems, the particles for both the upstream and downstream should be counted and recorded. Repeat twice more for a total of three upstream and three downstream samples. Calculate the filter efficiency for each of the three samples.
- i) Examine the three filter efficiency measurements for trends. Filter efficiency may decrease or increase as a filter is loaded. If the efficiency aerosol concentration is too high, then it might load the filter enough to alter the measured efficiency. In that case the measured efficiency will not represent the initial efficiency.
  - If there is trend in the filter efficiency that is significant with respect to the test system repeatability established during system validation, then the current test is invalid and the efficiency aerosol concentration should be reduced prior to any additional tests. After reducing the concentration of the test aerosol, start a new test with a new filter.
  - If there is no significant trend in the filter efficiency from the beginning to the end of these tests, calculate the initial efficiency by summing the counts in each size range from the three upstream samples for the total upstream count in each size range. Similarly, sum the counts from the three downstream samples. If the upstream sample time is not the same as the downstream sample time, then the sample times shall be recorded for use when calculating the fractional efficiency.
- j) If these initial efficiency tests are to be followed by a loading test, begin that test immediately upon completion of the initial efficiency test. Do not interrupt the air flow through the filter under testing until the entire test is completed after the first load, as this can alter the performance of the filter. If only the initial efficiency tests are done, then go to r) to calculate the results.
- k) The particle counters shall be protected from the high concentrations of ISO 12103-1 A2 fine test dust that are present during filter loading.
- l) If it is very time consuming to obtain stable efficiency test aerosol concentration, the efficiency test aerosol can be run throughout the duration of this test, provided that the concentration of the loading dust is more than  $100 \times$  the efficiency test aerosol concentration. This will also speed up the test procedure.
- m) Start feeding the ISO 12103-1 A2 fine test dust. Load the filter with ISO 12103-A2 fine dust until the pressure loss across the filter has increased to the first increment as calculated in 5.2.1 c). Remember to subtract the tare pressure loss when calculating the filter pressure loss.
- n) Stop the dust feeder and start the efficiency test aerosol if it is not already running. Allow the upstream and downstream aerosol concentration to stabilize for a maximum of 5 min to the efficiency test aerosol conditions.
- o) Measure the fractional efficiency with the particle counters as described in h) and i). Shut off the efficiency test aerosol unless it is running continuously [refer to l)].
- p) Protect the particle counters from the high concentration of loading test dust. Resume feeding the loading dust until the pressure loss across the filter has reached the second incremental pressure loss as calculated in 5.2.1 c).
- q) Repeat the cycle of measuring fractional efficiency and loading until the final pressure loss has been reached and the final fractional efficiency has been measured.
- r) Calculate the filter pressure loss by subtracting the tare pressure loss, and correcting the values per annex C.
- s) Calculate the efficiency and confidence limits for each particle size range and each loading increment using the methods given in annex B. For calculations when the smallest count exceeds 500, the efficiency may be calculated without using the upper and lower confidence limits (counts of 500 or more means that the 95 % confidence limits differ from the calculated value by less than  $\pm 9$  % of reading).
- t) Use the form given in annex A to report the results.

### 5.2.3 Filter dust capacity

The filter dust capacity test shall be carried out according to the ISO 5011 procedure using ISO 12103-1 A2 fine test dust.

**Annex A**  
(normative)

**Test report**

Use the following test report form to record and report the test results. Fractional efficiency measurements shall be plotted at the log mean diameter of the size ranges.

**Air filters for road vehicles passenger compartments — Test report for particle filtration**

**General details**

**Test unit:** Filter element: .....

Manufacturer: .....

Test dust (ISO 12103-1 A2 fine or KCl):

Test dust feeding equipment for efficiency test, type and settings: .....

Test dust feeding equipment for dust capacity test, type and settings: .....

Size selecting diluter (On / Off)?: .....

Particle counter, type: .....

Particle counter, sample flow: .....

Neutralizer for efficiency aerosol, type: .....

**Test conditions**

Test dust: .....

Barometer reading: before test: ..... hPa; after test: ..... hPa;

NOTE 1 000 hPa = 10<sup>5</sup> Pa = 1 bar; 1 mbar = 1 hPa

Temperature: before test: ..... °C; after test: ..... °C;

Relative air humidity: before test: ..... %; after test: ..... %;

Nominal flowrate: ..... m<sup>3</sup>/h; test flowrate: ..... m<sup>3</sup>/h;

Total number counts/cm<sup>3</sup>: .....

Dust concentration during measurement of dust capacity: ..... mg/m<sup>3</sup>

Neutralization used during measurement of dust capacity (Y/N): .....

Pressure of feeding device: 0,1 MPa (1 bar)

**Test results**

**Initial pressure loss versus flow rate**

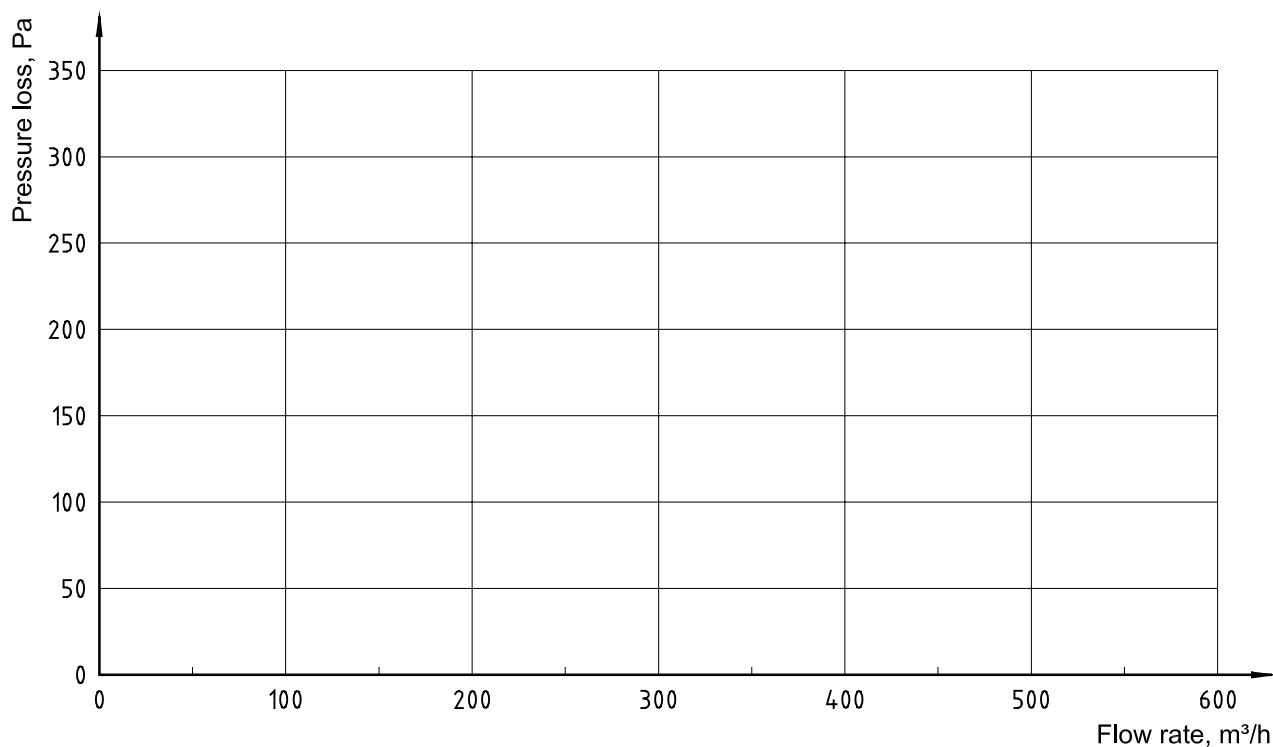

**Fractional filtration efficiency as function of particle size and dust capacity at test flow rate**

**Test dust: KCL**

Measured:  aerodynamic  
 optical

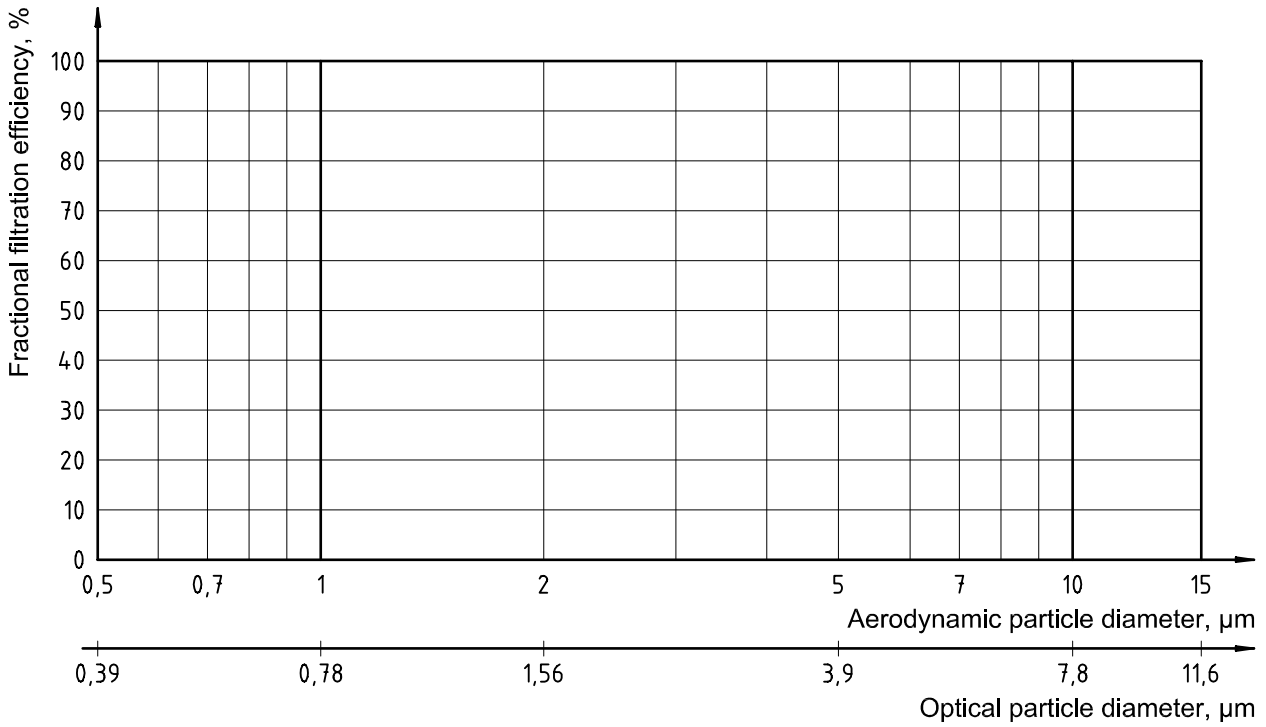

Test dust: **A2 fine**

Measured:  aerodynamic  
 optical

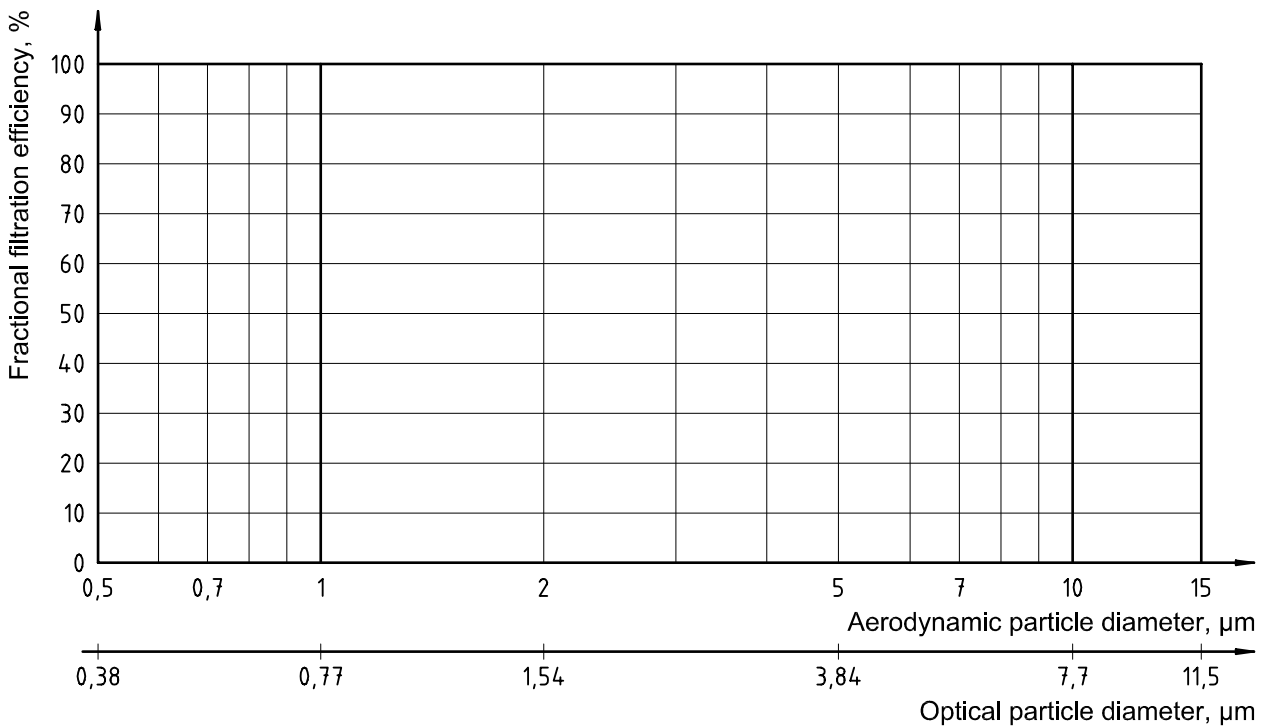

**Pressure loss versus loading**

Test flow rate: .....m<sup>3</sup>/h

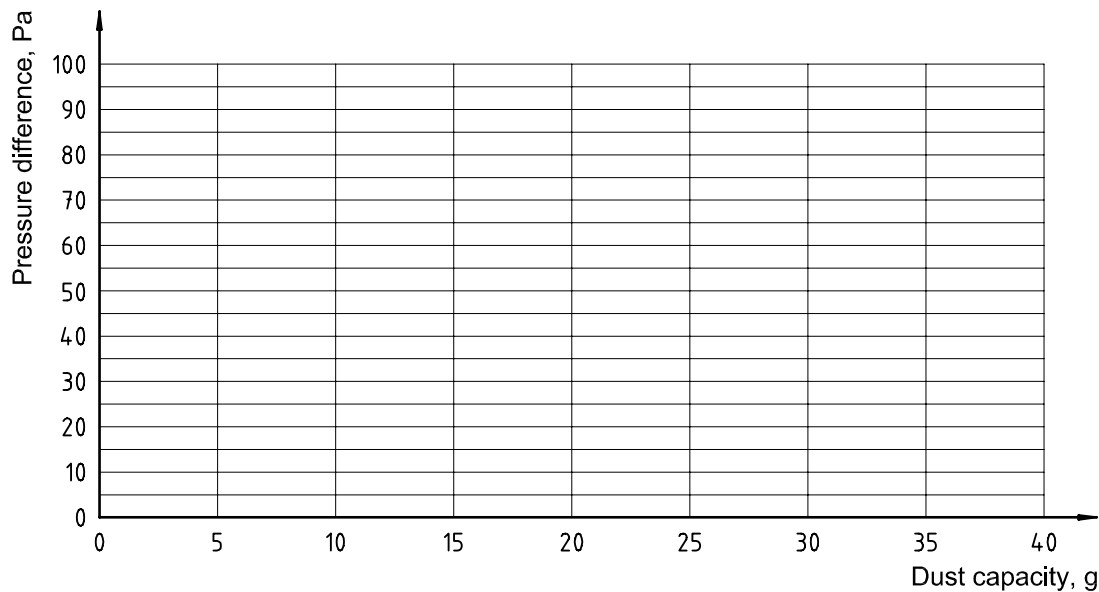

**General remarks**

.....  
.....  
.....

Date:

Test performed by:

.....

## Annex B (normative)

### Efficiency data reduction

#### B.1 Introduction

##### B.1.1 General

When using particle counters to evaluate fractional filtration efficiency, it is necessary to consider limitations imposed by the method. The efficiency is determined by comparing the particles detected upstream of the filter to the particles detected downstream. Inevitably there are differences between the upstream and downstream sampling and detection equipment. This section presents a method to calculate correlation ratios to minimize the errors due to the difference between the upstream and downstream equipment. In addition to correcting for small variations between upstream and downstream equipment; the correlation ratio may be used to correct for unequal upstream and downstream sample times.

When the number of particles counted in any size class is low, potential errors may occur as a result of counting a few randomly occurring events. The method to quantify the size of the potential error from counting a few particles is presented. Because the error due to counting random events is a function of the total number of particles counted, it is important to work with the actual counts, not concentrations or averages. In the efficiency tests described in this test code, three upstream and three downstream samples are counted. The counts from those three samples shall be added together to obtain total upstream and total downstream counts in each size class. The totals are used for the calculations described in this annex. Using average counts will cause the calculated confidence limits to be worse than they should be.

These data reduction techniques only address the correlation of upstream and downstream sampling and counting, and the statistics of counting a small number of particles. The confidence intervals calculated with the methods in this annex do not necessarily reflect the overall test accuracy or precision. The test accuracy and precision can not be any better than the confidence interval calculated from the counting statistics, but may be worse because these data reduction techniques do not address any other sources of error. To minimize the other sources of errors, it is important that the test system be qualified and calibrated as described in the body of this test code.

Clauses B.2 to B.5 present “cook book” calculations; B.6 presents more detail, including a sample calculation. The calculations are carried out in terms of penetration, the ratio of the concentration of particles downstream of the filter to the concentration upstream. The penetrations can be converted to efficiencies after the calculations are completed. The calculations are carried out for each particle size class of interest.

##### B.1.2 Symbols and subscripts used in all equations

The symbols and subscripts given in Table B.1 are used for the equations.



Table B.1 — Symbols and subscripts

Symbol	Meaning
$N$	particle counts
$R$	correlation ratio
$P$	penetration
$T$	sampling time
$E$	efficiency
Subscript	
o	observed
ucl	upper confidence limit
lcl	lower confidence limit
spec	specified performance
c	correlation (i.e., no filter installed)
t	testing a filter
uc	upstream during correlation
dc	downstream during correlation
ut	upstream during test
dt	downstream during test

## B.2 Correlation ratio

### B.2.1 Observed value — Correlation ratio

Using counts obtained without filter installed, the observed correlation ratio should be calculated for each size class as shown in equation B.1:

$$R_o = \frac{N_{o,dc}}{N_{o,uc}} \quad (\text{B.1})$$

### B.2.2 UCL and LCL values — Correlation ratio

For numbers  $N \leq 50$ , Table B.5 should be used to determine the 95 % upper and lower confidence limits for each size class for the upstream and downstream counts without filter installed.

For numbers  $N > 50$ , then

$$N \pm 2\sqrt{N} \quad (\text{B.2})$$

should be used to determine the upper and lower confidence limits for each size class. For example:

$$N_{ucl,dc} = N_{o,dc} + 2\sqrt{N_{o,dc}}$$

See equations B.3 and B.4 for confidence limits on the correlation ratio.

$$R_{ucl} = \frac{N_{ucl,dc}}{N_{lcl,uc}} \quad (\text{B.3})$$

$$R_{lcl} = \frac{N_{lcl,dc}}{N_{ucl,uc}} \quad (\text{B.4})$$

### B.3 Penetration

#### B.3.1 Observed — Penetration

With the test filter installed, upstream and downstream counts should be obtained to calculate the observed penetration for each size class, according to:

$$P_o = \frac{N_{o,dt}}{N_{o,ut} \times R_o} \tag{B.5}$$

#### B.3.2 UCL and LCL values — Penetration

The UCL and LCL values should be calculated for the upstream and downstream counts for each size class, using Table B.5 for numbers  $N \leq 50$  and equation B.2 for numbers  $N > 50$ . The UCL and LCL of the penetration should be calculated for each size class as shown in equations B.6 and B.7:

$$P_{ucl} = \frac{N_{ucl,dt}}{N_{lcl,ut} \times R_{lcl}} \tag{B.6}$$

$$P_{lcl} = \frac{N_{lcl,dt}}{N_{ucl,ut} \times R_{ucl}} \tag{B.7}$$

### B.4 Calculations for unequal sample times

If

$$\frac{T_{uc}}{T_{dc}} = \frac{T_{ut}}{T_{dt}} \tag{B.8}$$

then no adjustments for sampling time need to be made.

If this condition is not met, then the equation for the observed penetration is as shown in equation B.9:

$$P_o = \frac{T_{ut}}{T_{dt}} \times \frac{N_{o,dt}}{N_{o,ut} \times \frac{N_{o,dc}}{N_{o,uc}} \times \frac{T_{uc}}{T_{dc}}} \tag{B.9}$$

The equations for the UCL and LCL values of the penetration are as shown in equations B.10 and B.11:

$$P_{ucl} = \frac{T_{ut}}{T_{dt}} \times \frac{N_{ucl,dt}}{N_{lcl,ut} \times \frac{N_{lcl,dc}}{N_{ucl,uc}} \times \frac{T_{uc}}{T_{dc}}} \tag{B.10}$$

$$P_{lcl} = \frac{T_{ut}}{T_{dt}} \times \frac{N_{lcl,dt}}{N_{ucl,ut} \times \frac{N_{ucl,dc}}{N_{lcl,uc}} \times \frac{T_{uc}}{T_{dc}}} \tag{B.11}$$

## B.5 Efficiency

The efficiency for each size class is calculated from the penetration, as follows in equations B.12 to B.14:

$$E_o = 1 - P_o \quad (\text{B.12})$$

$$E_{lcl} = 1 - P_{ucl} \quad (\text{B.13})$$

$$E_{ucl} = 1 - P_{lcl} \quad (\text{B.14})$$

## B.6 Poisson statistics and counting

### B.6.1 Theory

When a well-mixed, stable aerosol penetrates a filter, penetrating particles will appear downstream of the filter (or in a small downstream air sample), randomly, but at some average population density. A particle counter will detect these randomly in time, but at an average rate. For the purpose of calculating penetration, the average rate (particles per unit time or per unit volume) is obtained from the cumulative count measured over the time period of the test or over the volume sampled.

The statistics of particle counting become increasingly important as the filter penetration, and hence downstream counts, decrease. These variations are described by Poisson statistics. Of primary importance to this type of testing is the relationship between the results of a single test and the results that would be obtained from a test of infinite duration — the true mean result. This relationship between an observed result and the implied confidence limits on the true mean result is described very well in the literature [13].

### B.6.2 Practice

When top-performance, noise-free particle counters are used in a good duct according to this Technical Specification, count statistics may become the largest source of uncertainty when testing highly efficient filters.

### B.6.3 Recommendation

#### B.6.3.1 Determination of confidence limits on a count

This procedure uses particle count data to establish the confidence limits on penetration. Equation B.2 gives the 95 % confidence limits on a single observed particle count,  $N$ , when  $N > 50$ . For a single observed particle count  $N$ , there is 95 % confidence that the true mean count is between the upper and lower limits given by the equation. The true mean count is the average count that would be obtained if the tests were repeated indefinitely [14]. An example of confidence limits is shown by Table B.2.

**Table B.2 — Example of confidence limits**

95 % confidence limits		
Observed count $N$	Lower	Upper
100	80	120
10 000	9 800	10 200

Once the confidence limits on a particle count are established, it is necessary to establish the confidence limits on the correlation ratio and penetration.

**B.6.3.2 Correlation Ratio**

Statistical uncertainty exists in the ratio of downstream to upstream counts, with no filter in the system. This uncertainty should be established before the penetration is calculated. For example consider a correlation where the observed counts are 10 000 upstream and 12 000 downstream (see Table B.3):

**Table B.3 — Example of correlation ratios**

95 % confidence limits on correlation ratio		
Observed Value	Lower	Upper
10 000 counts upstream	9 800	10 200
12 000 counts downstream	11 781	12 219

NOTE In this example, the upstream counts are less than the downstream counts because of slight differences in the sampling systems and counters.

Thus, the confidence limits on the correlation ratio are:

- observed:  $R_o = 12\ 000/10\ 000 = 1,20$
- lower:  $R_{lcl} = 11\ 781/10\ 200 = 1,15$
- upper:  $R_{ucl} = 12\ 219/9\ 800 = 1,25$

If the uncertainty in the correlation ratio is significantly less than the uncertainty in the penetration of the filter under test, it is reasonable to use the observed value of the correlation ratio. Otherwise, the 95 % confidence limits of the correlation ratio should be used.

**B.6.3.3 Penetration**

This correlation example is used to calculate the penetration of a filter test, as shown in Table B.4.

**Table B.4 — Example of filter penetration**

95 % confidence limits on filter penetration		
Observed value	Lower	Upper
1 000 counts upstream	937	1 063
100 counts downstream	80	120

Using the 95 % confidence limits on the correlation ratio results in 95 % confidence limits on the penetration of:

- observed:  $P_o = 100/(1\ 000 \times 1,2) = 0,083 = 8,3\ %$
- lower:  $P_{lcl} = 80/(1\ 063 \times 1,25) = 0,060 = 6,0\ %$
- upper:  $P_{ucl} = 120/(937 \times 1,15) = 0,111 = 11,1\ %$

The efficiency is:

- observed:  $E_o = 1 - 0,083 = 0,917 = 91,7\ %$
- lower:  $E_{lcl} = 1 - 0,111 = 0,889 = 88,9\ %$
- upper:  $E_{ucl} = 1 - 0,060 = 0,940 = 94,0\ %$

In this example, it can be stated with 95 % confidence that the filter penetration is between 6,0 % and 11,1 %, or that the efficiency is between 88,9 % and 94,0 %.

Note the following.

- The particle size range in which the counts were obtained should also be given.
- This confidence level is based on counting statistics only.
- Other error sources may contribute to the uncertainty of the penetration and efficiency measurements.
- For very low penetration filters, the errors due to the counting statistics may be a major factor in determining the over all test precision. For higher penetration filters, when it is possible to obtain higher number counts, this error source becomes less important as compared to the other error sources.
- The statistical procedures described here apply only to raw count data. It is improper to apply these methods to data that have been scaled, averaged, multiplied by correlation ratios, converted to rates or concentrations, and so forth; to do so will yield erroneous results.

**Table B.5 — 95 % Confidence limits for the mean value of a Poisson variable**

Observed count <i>N</i>	Lower limit	Upper limit	Observed count <i>N</i>	Lower limit	Upper limit
0	0,0	3,7			
1	0,2	5,6	26	17,8	38,0
2	0,6	7,2	27	18,6	39,2
3	1,1	8,8	28	19,4	40,4
4	1,6	10,2	29	20,2	41,6
5	2,2	11,7	30	21,1	42,8
6	2,8	13,1	31	21,9	44,0
7	3,5	14,4	32	22,7	45,1
8	4,1	15,8	33	23,5	46,3
9	4,8	17,1	34	24,4	47,5
10	5,5	18,4	35	25,2	48,7
11	6,2	19,7	36	26,1	49,8
12	6,9	21,0	37	26,9	51,0
13	7,7	22,3	38	27,7	52,2
14	8,4	23,5	39	28,6	53,3
15	9,2	24,8	40	29,4	54,5
16	9,9	26,0	41	30,3	55,6
17	10,7	27,2	42	31,1	56,8
18	11,4	28,4	43	32,0	57,9
19	12,2	29,6	44	32,8	59,0
20	13,0	30,8	45	33,7	60,2
21	13,8	32,0	46	34,5	61,3
22	14,6	33,2	47	35,4	62,5
23	15,4	34,4	48	36,3	63,6
24	16,2	35,6	49	37,1	64,8
25	17,0	36,8	50	38,0	65,9

## Annex C (normative)

### Pressure loss data reduction

If the temperature and pressure at the filter under test are different than the standard conditions of 23 °C and 101,3 kPa; then the measured pressure loss shall be corrected to indicate the pressure loss that would be measured if the conditions were standard. The correction required for the pressure loss measurement depends on the test conditions and on the type of filter being tested. For tests according to this part of ISO/TS 11155, the temperature shall be controlled to the standard temperature so the primary variable is the absolute pressure at the filter under test. It is required that testing be conducted at specified actual volume flow rates in order to minimize changes in the efficiency measurement due to different velocities. Therefore, if the absolute pressure at the filter under test is not standard pressure, then the measured filter pressure loss is corrected as follows.

NOTE This is independent of the corrections required for the flow rate measurement device that are required to establish the correct actual volume flow rate at the filter under test.

Measure the filter pressure loss,  $\Delta P$ , as a function of volume flow rate,  $Q$ . Plot the measured pressure loss,  $\Delta P_m$ , as a function of the measured flow rate,  $Q_m$ . Note that in this test method,  $Q_m$ , is the actual volume flow rate at the filter at the test conditions. Find  $K_1$  and  $K_2$  by doing a least squares curve fit of the following equation to the data.

$$\Delta P_m = K_1 \times \eta_m \times Q_m + K_2 \times \rho_m \times Q_m^2 \quad (\text{C.1})$$

Where  $\eta_m$  and  $\rho_m$  are the dynamic viscosity and mass density of air at the filter at the test conditions.

Use equation C.2. to calculate the standard filter pressure loss  $\Delta P_S$  at the specified flow rate in the range of flow rates measured. Extrapolation to flow rates outside of the measured range is not recommended.

$$\Delta P_S = K_1 \times \eta_S \times Q + K_2 \times \rho_S \times Q^2 \quad (\text{C.2})$$

where  $\eta_S$  and  $\rho_S$  are the dynamic viscosity and mass density of air at standard conditions.

NOTE Since the temperatures are controlled to standard conditions, the correction due to the  $K_1 \eta_S Q$  term will be negligible.

.....

## Annex D (informative)

### Determination of maximum efficiency aerosol concentration

In 4.2.5.2 it is recommended that fractional efficiency tests be performed as a function of particle concentration for individual particle counters used for filter testing. An example is illustrated in Figure D.1. When the concentration is low, the fractional efficiencies are not stable due to lack of enough counts as seen on left hand side of the curves. The fractional efficiencies will then be stable over a range of particle concentrations. As the particle concentration is further increased, the efficiency of the lowest channel will start to drop due to the coincidence problem. The appropriate particle concentration range should be the range in which the fractional efficiencies are stable (e.g. 40 000 to 100 000 particles/cubic foot for the 0,3  $\mu\text{m}$  to 0,5  $\mu\text{m}$  channel shown in Figure D.1). It should be noted that the appropriate particle concentration range for different types of challenge aerosol (e.g. KCl, ISO dust, DOP, DOS) and different particle counters may be different. The tests described here should be performed when different counters or different challenges aerosol are used.

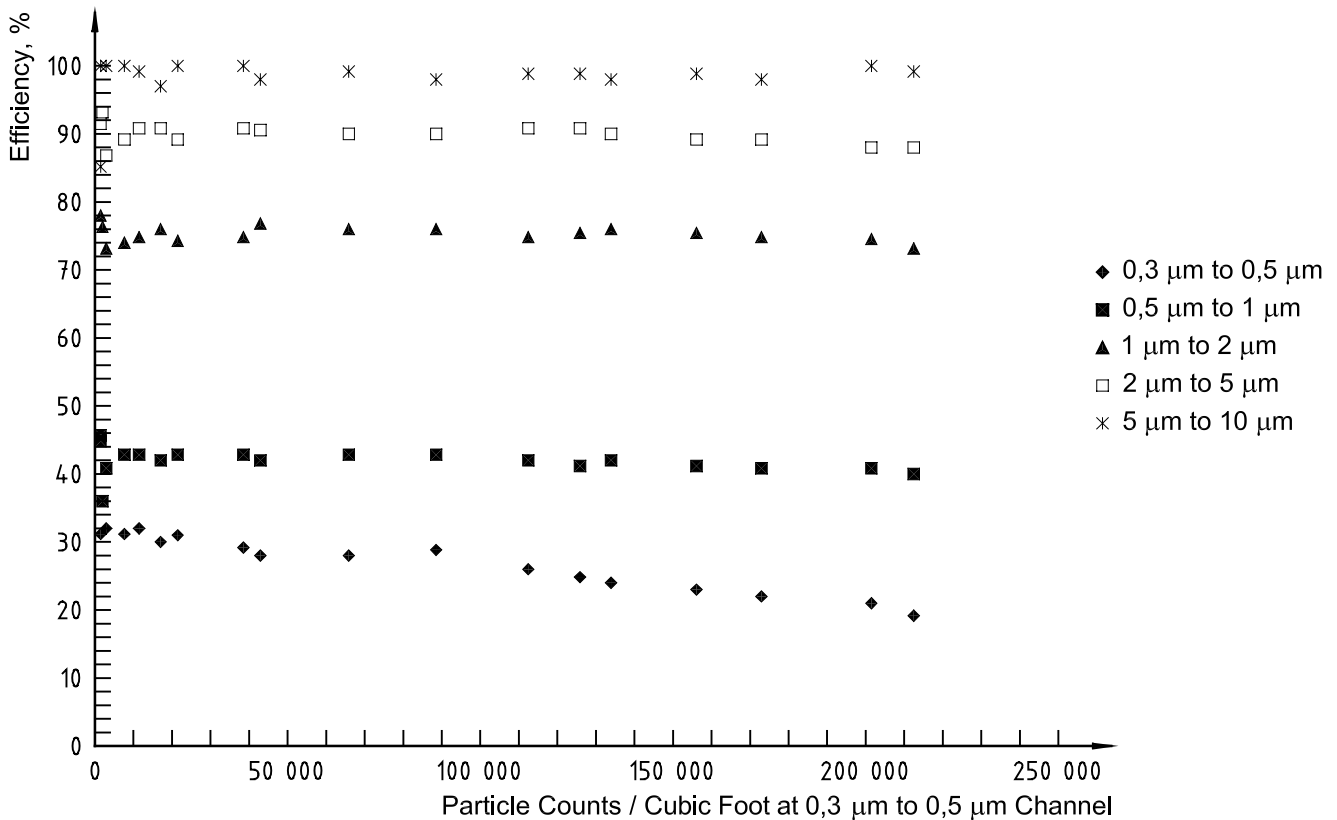

Figure D.1 — Efficiency at various sizes vs. particle counts (NaCl)

## Annex E (normative)

### Check lists for accuracy requirements, validation and routine operation

The following are lists of the items that need to be designed in, verified, measured, calibrated, and/or certified to insure that a test system meets the intent of this part of ISO/TS 11155, which describes the required performance of the test system rather than requiring specific hardware and specific procedures. Hence it is incumbent upon the builder and user of the test system to verify that the required performance is in fact achieved.

The first list, instrument accuracy requirements, contains instrumentation accuracy and other requirements that are generally established by the instrumentation used in the test system. The criteria for most items on this list are met with traceable calibration. The second list, validation, contains system characteristics that are established by system design. These characteristics need to be measured once to verify the system design and to verify the initial performance of the test system. The criteria for most items on the validation list are verified by measurement of the characteristic of the test system. Note that 4.4 gives requirements for documenting the test system validation. The third list, routine operation, contains calibrations, measurements and activities that need to be repeated on a scheduled basis to ensure the continued repeatability and reproducibility of the test system.

Numbers refer to the relevant subclauses of this part of ISO/TS 11155.

**Table E.1 — Instrument accuracy requirements**

Subclause	Description	Criterion	Comments
4.1.1	Measurement accuracy, air flow rate	$\pm 3 \%$	$\pm 2 \%$ repeatability
4.1.1	Measurement accuracy, air velocity	$\pm 5 \%$	
4.1.2	Measurement accuracy, pressure loss	$\pm 2 \%$	
4.1.3	Measurement accuracy, temperature	$\pm 2 \text{ }^\circ\text{C}$	
4.1.4	Measurement accuracy, weight	$\pm 0,1 \%$	
4.1.5	Measurement accuracy, relative humidity	$\pm 5 \%$ RH	
4.1.6	Measurement accuracy, barometric pressure	$\pm 300 \text{ Pa}$	
4.2.5	Particle counters, size range, (micrometers)	0,3 to 10 0,5 to 15	geometric aerodynamic

The order in which the validation tests are done is important. The order given in the Table E.2 may be used as a guide.

In the case of a plenum chamber design, validation tests are required to be performed using an orifice without a filter or other flow-restricting device in place. The orifice shall be 200 mm  $\times$  300 mm with the 300 mm axis parallel to the duct's longer axis (if any) and centred in the duct.

In case of a tapered duct, the provisions of the validation contained in the following subclauses need to be done for each different duct without a filter in place: 4.2.1.1, 4.2.1.4, 4.2.2.2, 4.2.4.2, and 4.2.4.3 ( the tests dealing with the uniformity of flow and aerosol at the test filter mounting location.) See also Table E.3.



Table E.2 — Validation

Subclause	Description	Criterion	Comments
4.2.1.1	Test system, conductive and grounded		Verify with continuity tester
4.2.1.1	Test system, vertical from dust injection to downstream sample		Verify by inspection
4.2.1.1	Test system, minimize particle loss		Verify by correlation measurement, see 4.2.4
4.2.1.2	Temperature control, see also 4.3.4, 5.4	23 °C ± 5 °C	Shall maintain during test
4.2.1.2	Relative humidity control, see also 4.3.4, 5.4	55 ± 15 % RH	Shall maintain ± 10 % RH during test
4.2.1.2	Test duct air tightness	< 100 l/min at 500 Pa	Test per industry accepted practice <sup>a</sup>
4.2.1.2	Air cleanliness, background particle count	< 1 % of efficiency challenge	Per size channel.
4.2.1.3	Flow rate measurement, shall be accurate as mounted in system, see also 4.2.7	± 3 % accuracy	± 2 % repeatability
4.2.1.2	Air flow rate, Delivery of user specified flow rate.	typical flows 150 m <sup>3</sup> /h to 680 m <sup>3</sup> /h	Minimum at which system needs to be validated is 150 m <sup>3</sup> /h. Shall be able to maintain flow rate during loading
4.2.1.1	Air flow uniformity	± 10 %	
4.2.1.2	Pressure loss measurement range, typical maximum 1000 Pa	expected + 10 %	
4.2.1.4	Pressure loss tap locations	see 4.2.1.4	By inspection
4.2.1.4	Pressure loss measurement accuracy	± 2 %	
4.2.1.5	See 4.2.4.2 and 4.2.4.3 below		
4.2.1.6	Test filter mounting, horizontal, centred, sealed		
4.2.2.1	Sample probe isokinetic	± 20 %	By calculation from flow rates and diameters
4.2.2.1	Sample probe location, upstream, centred, close to filter	100 mm	Approximate distance, allows for different thickness filters
4.2.2.1	Sample probe location, downstream, centred more than 75 mm downstream of filter.	75 mm minimum	
4.2.2.2	Sample line design and conductivity		Inspection and electrical continuity to ground
4.2.4.2	Aerosol generator, fraction efficiency, stable concentration (within each size channel)	± 10 % ± 20 %	0,3 µm to 5 µm 5 µm to 10 µm
4.2.4.2	Aerosol generator, fraction efficiency, stable size distribution (within each size channel)	± 10 % ± 20 %	0,3 µm to 5 µm 5 µm to 10 µm
4.2.4.2	Efficiency aerosol, uniformity (within each size channel)	± 10 % ± 20 %	0,3 µm to 5 µm 5 µm to 10 µm
4.2.3	Aerosol generator, fraction efficiency, sufficient number upstream in each size	500	Typical minimum
4.2.3	Aerosol, fraction efficiency, sufficient number in each size, downstream count	typically 100	Report error bars for efficiency measurements
4.2.3.1 4.2.6	Aerosol, fraction efficiency, charge neutralized	Follow 4.2.6 see annex G	
4.2.3.3	Aerosol, fraction efficiency, dryness		Applies to KCl aerosol only

Table E.2 (continued)

Subclause	Description	Criterion	Comments
4.2.3.1 5.2.2 i)	Fractional efficiency aerosol, concentration low enough so there is no change in efficiency during test (i.e. no loading effects)		No significant trend compared to the test system repeatability as measured in 4.2.8. For validation, it is recommended that this test be done for 10 repetitions rather than 3 that are required for each test.
4.2.3.1 4.2.3.4 4.2.4.3	Dust feeder for loading aerosol, stable concentration	$\pm 20 \%$	
4.2.3.4 4.2.4.3	Dust feeder for loading aerosol, concentration	50 mg/m <sup>3</sup> to 100 mg/m <sup>3</sup>	
4.2.3.4 4.3.1	Dust feeder for loading aerosol, size distribution in test duct		Use ISO 5011 disperser or demonstrated equivalent
4.2.4.3	Capacity challenge, uniformity	$\pm 10 \%$	
4.2.5.3	Particle counters, Flow rate,	$\pm 5 \%$	
4.2.5.1	Particle counters, primary size calibration with PSL		See ASTM F-328.
4.2.5.2	Aerosol, fraction efficiency., concentration below particle counter limit to prevent coincidence.	Max. of 5 % decrease	Procedure in annex D
4.2.4.2 Annex B	Correlation of sampling systems and counters (zero efficiency. filter)	Between 0,7 and 1,6	In plenum chamber type systems, measure with filter mounting plate in place
4.2.8	Repeatability, pressure loss and efficiency	$\pm 5 \%$	To be done at start up and yearly
4.4	Reference filter test	N/A	Use to monitor changes in test system performance
4.4	Performance certification documentation	N/A	For the test system validation to be complete it shall be documented
<p><sup>a</sup> An example is SMACNA (Sheet Metal Contractors National Association) Air duct leakage test manual, available from: ASHRAE Customer Service, 1791 Tullie Circle, NE, Atlanta, GA 30329-2305.</p>			

Table E.3 — Routine operation

Subclause	Description	Criterion	Frequency <sup>a</sup>	Comments
4.2.4.2.5	Correlation (see also annex B)	Between 0,7 and 1,6	Daily	Also filter geometry change
5.1.2	Pressure loss across empty test section (tare pressure loss)		Each test	
5	Particle counter zero check		Daily	Max. 10 counts per minute
4.2.1.2	Air cleanliness, background particle count	< 1 % of efficiency challenge	Daily	Per size channel
4.2.3.1 5.2.2 i)	Verify that efficiency aerosol does not load filter.		Each test	Look for changes significant with respect to system repeatability
4.4	Reference filter pressure loss and initial efficiency			Track for changes. Daily tests recommended
4.2.5.1	Particle counter accuracy check			Check with one size PSL if reference filter indicates a problem
4.2.5.1	Particle counter calibration with PSL		Yearly	
4.2.1.1	Air flow uniformity	± 10 %	Change	Each new filter mounting geometry or after any changes to test system
4.2.4.2	Efficiency aerosol, uniformity (within each size channel):  0,3 µm to 5 µm 5 µm to 10 µm	± 10 % ± 20 %	Change	Same
4.2.4.3	Loading test aerosol uniformity	± 10 %	Change	Same
4.2.3 4.2.3.3 4.2.4.3	Dust feeder for loading aerosol, stable concentration	± 20 %		
4.2.3.3 4.2.4.3	Loading test aerosol concentration	50 mg/m <sup>3</sup> to 100 mg/m <sup>3</sup>	Monthly	
5.2.2 h)	Efficiency aerosol generator response time		Yearly or change	
4.2.5.2	Coincidence error		Yearly or change	
4.2.1.2	Duct leak test	< 100 l/min at 500 Pa	Yearly or change	
4.2.3.1 4.2.6	Confirmation of neutralizer radioactivity or ionizer current	Follow 4.2.6 see Annex G	If electret reference filter test indicates problem	Also clean every 100 hours of operation
4.1	Calibration of air flow measurement	± 3 %	Yearly	
4.1	Calibration of pressure loss measurement	± 2 %	Yearly	
4.1	Calibration of other instrumentation (temperature, relative humidity, etc.			Per instrument manufacturer's recommendations or yearly
4.2.8	Repeatability	± 5 %	Yearly	
	Cleaning of test duct and components			Discretionary as needed

<sup>a</sup> Change refers to any change in the test system that might affect the performance.

## Annex F (normative)

### Aerodynamic diameter

In order to be able to describe the properties of non-spherical particles, the definition of equivalent diameters is necessary. For example, the deposition of airborne particles in a filter, transportation losses in ducts, and the behaviour of particles in the human respiratory tract are based on the particles' aerodynamic properties. Therefore, the aerodynamic diameter is used to characterize particles in these cases.

The aerodynamic diameter is the diameter of a sphere of density 1 g/cm<sup>3</sup> with the same terminal velocity due to gravitational force in calm air, as the particle, under the prevailing conditions of temperature, pressure and relative humidity<sup>2)</sup>.

The aerodynamic diameter  $D_{ae}$  is defined as

$$D_{ae} = \left( \frac{C_c D_g \times \rho}{C_c D_{ae} \times \rho_o \times \chi} \right)^{1/2} \times D_g \quad (\text{F.1})$$

where

$D_g$  is the geometric (volume equivalent) diameter of the particle, g/cm<sup>3</sup>;

$\rho$  is the density of the test dust particle, g/cm<sup>3</sup>;

$\rho_o$  is the unit density, 1 g/cm<sup>3</sup>;

$C_c$  is the slip correction factor;

$\chi$  is the dynamic shape factor of the test dust particle.

For particle bulk material densities between 0,5 g/cm<sup>3</sup> and 3 g/cm<sup>3</sup>, and particles aerodynamically larger than 0,5 µm, equation F.1 simplifies to:

$$D_{ae} = \left( \frac{\rho}{\rho_o \times \chi} \right)^{1/2} \times D_g \quad (\text{F.2})$$

with a relative size error of less than 5 %.

The density and shape factors that shall be used are given in Table F.1.

---

2) For particles of aerodynamic diameter less than 0,5 µm, the particle diffusion diameter should be used instead of the particle aerodynamic diameter. The particle diffusion diameter is the diameter of a sphere with the same diffusion coefficient as the particle under the prevailing conditions of temperature, pressure and relative humidity.

Table F.1 — Density and shape factors

Efficiency aerosol	Density $\rho$ g/cm <sup>3</sup>	Dynamic shape factor $\chi$
ISO 12103-1 A2 fine test dust	2,65	1,57
KCl	1,97	1,2

An optical particle counter measures the optical equivalent diameter, where the light scattered by the particle equals the light scattered by a calibration particle (e.g. PSL) of known size. For precision work, an optical particle counter may be calibrated with the material to be measured. In that case, the optical equivalent diameter equals the geometric diameter. Then, equation F.2 can be used directly. Otherwise, the conversion of the optical equivalent diameter of the particles into the geometric (volume equivalent) diameter before applying equation F.2 is required to minimize the conversion error.

For the purposes of this part of ISO/TS 11155, use the optical equivalent diameter as the geometric (volume equivalent) diameter for calculating the aerodynamic equivalent diameter which is current practice.

## Annex G (normative)

### Methods for testing efficiency aerosol for proper neutralization

#### G.1 Introduction

This annex presents methods for determining whether the efficiency test aerosol is properly neutralized as required in 4.2.6. It is very difficult, costly and time-consuming to directly measure the charge distribution on the aerosol. Hence the methods described in this annex are indirect. The two methods described in detail are based on the effect of particle charge on the efficiency of electret filter media. Electret filters collect charged particles more efficiently than uncharged particles. Other methods are mentioned briefly.

Method one (see G.4) is applicable to radioactive type neutralizers and may also be used to check the concentration capabilities of electrostatic corona neutralizers, while method two (see G.5) is applicable only to electrostatic corona type neutralizers.

Both test methods involve finding of the minimum electret efficiency that can be obtained with the neutralizing equipment being tested. That does not necessarily mean that the aerosol is neutralized to the Boltzman equilibrium state. Nor does it mean that the aerosol is sufficiently neutralized to obtain repeatable efficiency measurements or to obtain efficiency measurements that will match other test systems. However, when these methods are not followed, it has been demonstrated that widely varying efficiency measurements can result. Some evidence exists that when these methods are followed, much better reproducibility is achieved.

The other methods listed here are not described in detail as they depend on expensive instrumentation that is not available in all filter test laboratories, instrumentation under development and not commercially available at the time of publication, or they are very time-consuming and require custom equipment (with some custom equipment involving potentially dangerous voltages). The list gives measurement methods; each of these measurement methods would be used in a procedure similar to that given below to determine the appropriate concentration for radioactive type neutralizers or the operating parameters for corona type neutralizers.

- Measure the neutral fraction utilizing a photometer after passing the aerosol through an electrostatic particle trap. Maximize the neutral fraction.
- Measure the neutral fraction utilizing a particle sizing instrument after passing the aerosol through an electrostatic particle trap. Maximize the neutral fraction.
- Measure the net charge deposited on the filter being tested. Adjust the neutralizer to minimize the net charge (it should be zero).
- Measure the net charge on the aerosol using an aerosol electrometer and minimize net charge on the aerosol (it should be zero).
- Measure the charge distribution using a range of voltages in an electrostatic particle trap and a particle sizing instrument. Compare to Boltzman distribution.

#### G.2 General procedure

The general procedure includes installation, verification, maintenance, and reverification.

- a) Install an appropriately sized aerosol neutralizer.
- b) Verify that it is functioning properly and adjust as needed using the methods in this annex.

- c) Measure and record the operating parameters: ionizer currents or voltages or both, radioactivity level, flow rate, aerosol concentration, etc.
- d) Periodically verify continued operation by checking an electret reference filter and other properties such as: ionizer current and radioactivity. The period is to be determined by the test system operator.
- e) Periodically clean and maintain the neutralizer.
- f) Periodically reverify proper functioning using the methods in this annex.

### G.3 Description of filters to be used

Both method 1 and method 2 depend on the use of a filter made with electret filter media. It is important to use a filter that owes a large part of its efficiency to electrostatic filtration mechanisms so that the effect can be easily measured. It is recommended that the initial efficiency in the 0,3  $\mu\text{m}$  to 0,5  $\mu\text{m}$  size range should be in the range of 20 % to 40 % when tested with a properly neutralized aerosol. For example, filters made with the following types of filter media will be suitable for this test:

- media made from fibres formed by slitting or shredding a thin, highly charged polymeric film, typical fibre cross-sections are in the order of 5  $\mu\text{m}$  by 30  $\mu\text{m}$ ;
- media made from a mixture of two types of polymeric fibres that become highly charged by tribo-electric mechanisms during manufacture, with fibres in the order of 10  $\mu\text{m}$  to 20  $\mu\text{m}$ .

Other filters in which the fibres are relatively large and the mechanical filtration mechanisms (diffusion, interception, and inertial) contribute only a minor part of the overall efficiency of the filter media may be used.

Filters made with such media and having 20 % to 40 % efficiency when tested with properly neutralized aerosol, may have efficiencies up to 90 % or higher if tested with charged (improperly neutralized) aerosol.

To confirm that electrostatic forces are the primary filtration mechanism, measure the filter efficiency before and after discharging the filter. One possible method of discharging an electret filter is to soak it in windshield washer fluid. The efficiency after discharge should be less than half the original efficiency.

### G.4 Method 1 — Reduction of concentration/flow rate to minimize electret efficiency

#### G.4.1 Procedure

- a) Remove radioactive neutralizer (or turn off the ionizer) and measure and record the efficiency of the electret filter.
- b) Install the neutralizer (or turn on the ionizer) and measure and record the efficiency.
- c) Reduce particles passing through the neutralizer per unit time by a factor of 2. This can be accomplished by reducing the concentration of aerosol passing through the neutralizer or by reducing the flow through the neutralizer. Maintain the same airflow through the filter for all tests. Measure and record the efficiency.
- d) Remove the neutralizer (or turn off the ionizer) measure and record the efficiency.

#### G.4.2 Analysis

Plot efficiency for the smallest size range as a function of particle flux (concentration or flow rate) through the neutralizer.

If efficiencies measured in steps a) and d) of the procedure according to G.4.1 are different, then the properties of the filter may be altered by the filter test: i.e. it is loading and increasing efficiency due to mechanical filtration

mechanisms, or the electret is degrading and losing efficiency. If the properties of the filter are being altered by the test, then either the efficiency test aerosol concentration will need to be reduced or the duration of the test will need to be reduced and the tests repeated.

If efficiencies a) to d) in the procedure are all the same, either the aerosol is not being charged during the process of aerosolizing it, or the neutralizer is not working.

If efficiencies b) and/or c) are less than efficiencies a) and d); then the aerosolization process charges the aerosol and the aerosol neutralizer is at least partially neutralizing the aerosol.

If efficiencies b) and c) are the same and less than efficiencies a) and d), it is likely that the neutralizer is adequately neutralizing the aerosol. In this case, repeat the procedure and increase the particles passing through the neutralizer per unit time by a factor of 2, and measure the efficiency.

If efficiency c) is lower than efficiency b); then the neutralizer is not adequately neutralizing the aerosol for the concentration in step b). In this case, repeat the procedure and reduce the particles passing through the neutralizer per unit time by another factor of 2 and measure the efficiency. Repeat until reducing the particle flux by a factor of 2 does not reduce the measured efficiency.

It is important to continue to check the efficiency with the neutralizer removed (or the ionizer turned off) to verify that the electret efficiency is not changing due to loading or electret discharging.

Figure G.1 presents a simulated example of a method one test sequence.

**G.4.3 Action**

Operate the neutralizer at one half of the highest particle flux for which the efficiency is the same as the next lower particle flux.

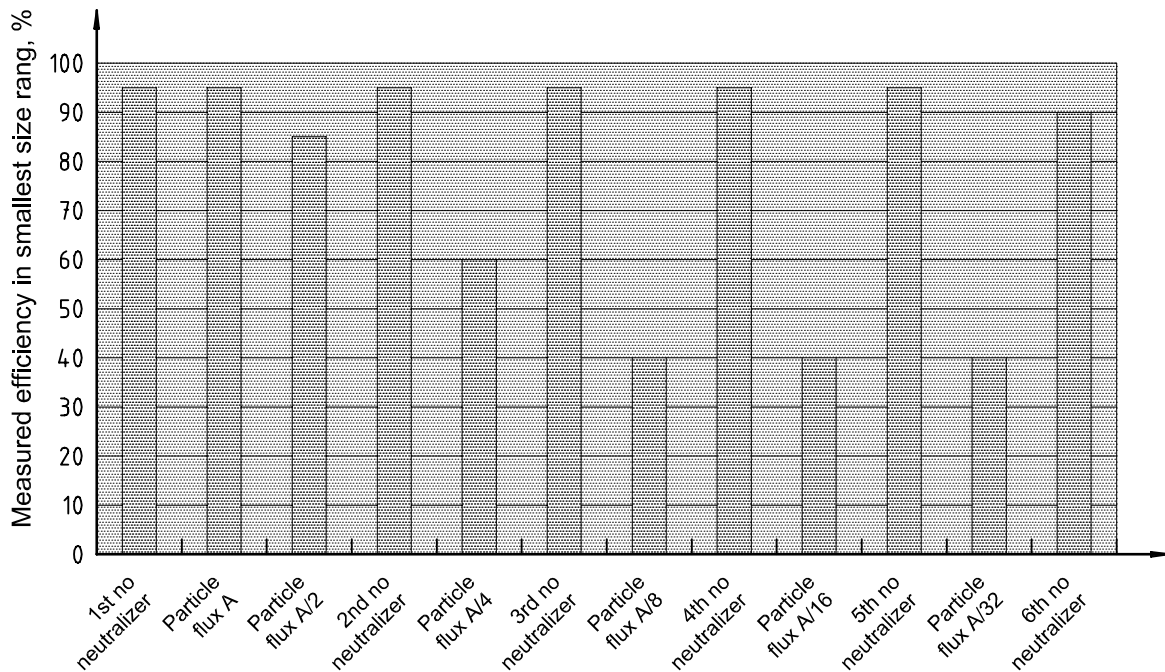

Particle flux A/16 is the highest flux that can be used.

The sixth no neutralizer test shows evidence that the electret is beginning to degrade.

**Figure G.1 — Simulated method 1 test sequence**



## G.5 Method 2 — Adjustment of ion output to minimize electret efficiency

### G.5.1 General

This method applies only to powered corona type ion sources that have adjustable voltage/current levels for both the positive and negative coronas. There are three phases in this test method. In the first phase, the proper excitation method is determined. In the second phase, the ratio of positive to negative ions is established. In the third phase, the proper concentration of ions is determined. Within each phase, some iteration (repeat testing while adjusting the settings) is required to get the best results. There is also a need to repeat the three phases, as adjustments made in one phase may affect the results in another. Because the method may require several iterations, it is important to carefully monitor the condition of the electret filter as described in the procedure for changes due to the testing.

### G.5.2 Procedure

#### G.5.2.1 Excitation type

Corona type ion sources can be operated in steady state (DC) mode, in a pulsed mode or in an AC mode. With steady state modes, recombination of the positive and negative ions may occur before the aerosol is properly neutralized. In pulsed or AC modes, it is possible to increase the charge on particles if there is not sufficient mixing.

- a) Take the ionizer out of the test system and aim the ionized air stream at the static voltmeter or place an electrostatic voltmeter in the test system. Adjust the controls of the ionizer to obtain a 0 V reading.
- b) Reinstall the ionizer or remove the static voltmeter from the test system.
- c) With the ionizer turned off, measure and record the efficiency of the electret filter.
- d) Turn on the neutralizer, measure and record the efficiency.
- e) Adjust the pulsing mode and frequency to minimize the measured efficiency of the electret filter. The effect is most noticeable in the small particle size ranges. Measure and record the efficiency. Note that some modes may cause the efficiency to be higher than the ionizer off case in step c). This is because the aerosol is being charged rather than neutralized.
- f) Turn off the ionizer, measure and record the efficiency. If the efficiency is different from that measured in c), then the test is affecting the charge on the filter media. If this happens, the efficiency test aerosol concentration, or the duration of the test, will need to be reduced and the tests repeated.

#### G.5.2.2 Balancing

- a) Take the ionizer out of the test system and aim the ionized air stream at the static voltmeter or place an electrostatic voltmeter in the test system. Adjust the controls of the ionizer to obtain a 0 V reading.
- b) Reinstall the ionizer or remove the static voltmeter from the test system.
- c) With the ionizer turned off, measure and record the efficiency of the electret filter.
- d) Turn on the neutralizer, and measure and record the efficiency.
- e) Adjust the positive and or negative corona current or voltage to minimize the measured efficiency of the electret filter. The effect is most noticeable in the small particle size ranges. Measure and record the efficiency. Note that conditions may cause the efficiency to be higher than the ionizer-off case in step c). This is because the aerosol is being charged rather than neutralized.
- f) Turn off the ionizer, measure and record the efficiency. If the efficiency is different from that measured in step c), then the test is affecting the charge on the filter media. If this happens, the efficiency test aerosol concentration will need to be reduced or the duration of the test will need to be reduced and the tests repeated.

### G.5.2.3 Concentration

#### G.5.2.3.1 Procedure

The balancing phase above is a prerequisite for the following procedure.

- a) With the ionizer off, measure and record the efficiency.
- b) Turn ionizer on. Measure and record the efficiency.
- c) Reduce particles passing through the neutralizer per unit time by a factor of 2. This can be accomplished by reducing the concentration of aerosol passing through the neutralizer or by reducing the flow through the neutralizer. Maintain the same airflow through the filter for all tests. (Rather than reducing the particle flux, the same effect can be created by increasing the ionizer current from step b). It is necessary to rebalance the positive and negative corona current or voltage as in the balancing phase to minimize the measured efficiency.) Measure and record the efficiency.
- d) Turn off ionizer, measure efficiency. If the efficiency is different from that measured in step a), then the test is affecting the charge on the filter media. If this happens, the efficiency test aerosol concentration will need to be reduced or the duration of the test will need to be reduced and the tests repeated.

#### G.5.2.3.2 Analysis

Plot efficiency for the smallest size range as a function of current, or voltage or particle flux (concentration or flow rate) through the neutralizer.

If efficiencies measured in steps a) and d) of G.5.2.3.1 are different, then the properties of the filter may be altered by the filter test: i.e. it is loading and increasing efficiency due to mechanical filtration mechanisms or the electret is degrading and losing efficiency. If the properties of the filter are being altered by the test, then either the efficiency test aerosol concentration will need to be reduced or the duration of the test will need to be reduced.

If efficiencies a) to d) are all the same, either the aerosol is not being charged during the process of aerosolizing it, or the neutralizer is not working.

If efficiencies b) or c) or both these are less than efficiencies a) and d); then the aerosolization process charges the aerosol and the aerosol neutralizer is at least partially neutralizing the aerosol.

If efficiencies b) or c) or both these are more than efficiencies a) and d), then the aerosol is being charged by the neutralizer rather than being neutralized.

If efficiencies b) and c) are the same and less than efficiencies a) and d), it is likely that the neutralizer is adequately neutralizing the aerosol. In this case, increase the particles passing through the neutralizer per unit time by a factor of 2 and measure the efficiency.

NOTE Rather than increasing the particle flux, the same effect can be created by decreasing the ionizer current from step b). It is necessary to rebalance the positive and negative corona current or voltage as in the balancing phase to minimize the measured efficiency.

If efficiency c) is lower than efficiency b); then the neutralizer is not adequately neutralizing the aerosol in step b). In this case, repeat the procedure and reduce the particles passing through the neutralizer per unit time by another factor of 2 (or increase the ionizer current) and measure the efficiency. Repeat until reducing the particle flux by a factor of 2 (or increasing the ionizer current) does not reduce the measured efficiency.

It is important to continue to check the efficiency with the neutralizer removed (or the ionizer turned off) to verify that the electret efficiency is not changing due to loading or electret discharging.

### G.5.3 Action

Operate the neutralizer at half the highest particle flux for which the efficiency is the same as the next lower particle flux.

## Bibliography

- [1] ISO 5167, *Measurement of fluid flow by means of orifice plates, nozzles and Venturi tubes inserted in circular cross-section conduits running full*
- [2] ISO 11841-1, *Road vehicles and internal combustion engines — Filter vocabulary — Part 1: Definitions of filters and filter components*
- [3] Final report on the project *Air filters for motor vehicle passenger compartments* by W. Koch and B. Ilgen, Fraunhofer Institute of Toxicology and Aerosol Research, Hannover, Germany (ISO/TC 22/SC 7/WG 3 N 265)
- [4] Summary of a round robin test according to the conditions of ISO/TS 11155-1 conducted in Germany (ISO/TC 22/SC 7/WG 3 N 295)
- [5] Summary of a round robin test to evaluate the influence of the different dust grades coarse, fine, and ultrafine conducted in Germany (ISO/TC 22/SC 7/WG 3 N 308)
- [6] Summary of pilot tests conducted in the USA (ISO/TC 22/SC 7/WG 3 N 309)
- [7] McDONALD B., Automobile cabin air filter test method, repeatability and reproducibility, *Advances in Filtration and Separation Technology*, Volume 11, Advancing Filtration Solutions, Edited by E. Baumann and L. Weisert, American Filtration and Separations Society, 1997, pp. 355-360
- [8] McDONALD B., Development of an international test standard for automobile passenger compartment particulate filters, *Proceedings of the Second International Filtration Conference*, Southwest Research Institute, 1998, pp. 158-172
- [9] IEST-R-P-CC007.1, *Testing ULPA Filters*, Institute of Environmental Sciences and Technology, 940 East Northwest Highway, Mount prospect, IL 60056, USA
- [10] VDI2066 Blatt 1:1975, Messen von Partikeln; Staubmessungen in strömenden Gasen; Gravimetrische Bestimmung der Staubbelastung; Übersicht
- [11] VDI2066 Blatt 2:1989, Messen von Partikeln; Manuelle Staubmessung in strömenden Gasen; Gravimetrische Bestimmung der Staubbelastung; Filterkopfgeräte (4 m<sup>3</sup>/h, 12 m<sup>3</sup>/h)
- [12] VAN SANTEN A. and GANNON E.J., Induct measurement of particulates, *Filtration and Separation*, Sept/Oct. 1987, pp. 328-336
- [13] BOX, G.E.P. HUNTER W.G. and HUNTER J.S., *Statistics for experimenters: an introduction to design, data analysis and model Building*, John Wiley & Sons, NY, 1978
- [14] ABRAMOWITZ M. and STEGUN I.A., *Handbook of Mathematical Functions with Formulas, Graphs, and Mathematical Tables*, Dover Publications, Inc., NY, 1972
- [15] HINDS, WILLIAM D., *Aerosol Technology*, John Wiley and Sons, 1982
- [16] BROWN, R.C., Review: Modern concepts of air filtration applied to dust respirators, *Ann. Occup. Hyg.* 33(4). pp. 615-644, 1989
- [17] FAIN, D.E. and Selby, T.W., Calibration and use of filter test facility orifice plates, 18th DOE Nuclear Airborne Waste Management and Air Cleaning Conference, 1984
- [18] EN 481:1993 Size fraction definitions for measurement of airborne particles

- [19] *Aerosol Measurement; Principles Techniques and Applications*, ed. WILLEKE K. and BARON P.A., van Nostrand Reinhold, New York, 1993
- [20] VDI 3489, Messen von Partikeln, Particulate matter measurement:
- *Part 1: Methods for characterizing and monitoring test aerosols (survey)*
  - *Part 3: Methods of characterizing and monitoring test aerosols — Optical particle counters*
  - *Part 8: Methods of characterizing and monitoring test aerosols — Time of flight spectrometer*
- [21] VDI 3491, Messen von Partikeln, *Particulate matter measurement*:
- *Part 1: Characteristics of suspended particulate matter in gasses; terms and definitions*
  - *Part 2: Production methods of test aerosols; Foundations and synoptics*
  - *Part 3: Characteristics of suspended particulate matter in gasses*
  - *Part 8: Generation of test aerosols from powders using a belt feed unit*
  - *Part 9: Generation of test aerosols with a rotating brush generator*
  - *Part 15: Generation of test aerosols — dilution systems with continuous volumetric flow*



---

---

**ICS 43.040.60**

Price based on 38 pages

© ISO 2001 – All rights reserved