

---

---

**Comparison of worldwide escalator  
and moving walk safety standards —**

**Part 2:  
Abbreviated comparison and  
comments**

*Comparaison des normes mondiales de sécurité des escaliers  
mécaniques et trottoirs roulants —*

*Partie 2: Comparaison abrégée et commentaires*





**COPYRIGHT PROTECTED DOCUMENT**

© ISO 2015, Published in Switzerland

All rights reserved. Unless otherwise specified, no part of this publication may be reproduced or utilized otherwise in any form or by any means, electronic or mechanical, including photocopying, or posting on the internet or an intranet, without prior written permission. Permission can be requested from either ISO at the address below or ISO's member body in the country of the requester.

ISO copyright office  
Ch. de Blandonnet 8 • CP 401  
CH-1214 Vernier, Geneva, Switzerland  
Tel. +41 22 749 01 11  
Fax +41 22 749 09 47  
copyright@iso.org  
www.iso.org

# Contents

Page

<b>Foreword</b> .....	<b>iv</b>
<b>Introduction</b> .....	<b>v</b>
<b>1 Scope</b> .....	<b>1</b>
<b>2 Acronyms, abbreviated designations, and terminology</b> .....	<b>1</b>
2.1 Acronyms and abbreviated designations.....	1
2.2 Terminology (list of terms used in the codes).....	2
<b>3 Basis for escalator and moving walk safety standards</b> .....	<b>3</b>
3.1 Historical origin and development of standards.....	3
3.1.1 European Standard EN 115-1.....	3
3.1.2 North American Standard A17.1/B44.....	4
3.1.3 The Japanese codes.....	5
3.2 General — Technical basis and structure of standards.....	8
3.3 Definitions.....	9
<b>4 Selected topics</b> .....	<b>11</b>
4.1 General.....	11
4.2 Enclosure, inspection doors.....	12
4.3 Steps and pallets.....	15
4.4 Belts.....	18
4.5 Drive unit.....	18
4.6 Balustrade.....	25
4.7 Handrail system.....	29
4.8 Landings.....	30
4.9 Machinery spaces, driving stations, and return stations.....	33
4.10 Electric installation and appliances.....	34
4.11 Protection against electrical faults — Controls.....	35
4.12 Information for use.....	42
4.13 Building interfaces.....	45
<b>Annex A (informative) Figures of EN115-1</b> .....	<b>48</b>
<b>Annex B (informative) References in the compared codes</b> .....	<b>51</b>
<b>Annex C (informative) Addresses of standardization bodies occupied with the compared codes</b> .....	<b>55</b>

## Foreword

ISO (the International Organization for Standardization) is a worldwide federation of national standards bodies (ISO member bodies). The work of preparing International Standards is normally carried out through ISO technical committees. Each member body interested in a subject for which a technical committee has been established has the right to be represented on that committee. International organizations, governmental and non-governmental, in liaison with ISO, also take part in the work. ISO collaborates closely with the International Electrotechnical Commission (IEC) on all matters of electrotechnical standardization.

The procedures used to develop this document and those intended for its further maintenance are described in the ISO/IEC Directives, Part 1. In particular the different approval criteria needed for the different types of ISO documents should be noted. This document was drafted in accordance with the editorial rules of the ISO/IEC Directives, Part 2 (see [www.iso.org/directives](http://www.iso.org/directives)).

Attention is drawn to the possibility that some of the elements of this document may be the subject of patent rights. ISO shall not be held responsible for identifying any or all such patent rights. Details of any patent rights identified during the development of the document will be in the Introduction and/or on the ISO list of patent declarations received (see [www.iso.org/patents](http://www.iso.org/patents)).

Any trade name used in this document is information given for the convenience of users and does not constitute an endorsement.

For an explanation on the meaning of ISO specific terms and expressions related to conformity assessment, as well as information about ISO's adherence to the WTO principles in the Technical Barriers to Trade (TBT) see the following URL: [Foreword - Supplementary information](#)

The committee responsible for this document is ISO/TC 178, *Lifts, escalators and moving walks*.

This second edition cancels and replaces the first edition (ISO/TR 14799-2:2005), which has been technically revised.

ISO/TR 14799 consists of the following parts, under the general title *Comparison of worldwide escalator and moving walk safety standards*:

- *Part 1: Rule by rule comparison*
- *Part 2: Abbreviated comparison and comments*

[Annexes A](#) and [B](#) form an integral part of this part of ISO/TR 14799.

## Introduction

At the 1995 plenary meeting of ISO/TC 178, the work on a comparison of worldwide standards which includes the American, Australian, European, Russian, and Japanese escalator and moving walk safety code was passed to ISO/TC 178 (Resolution Singapore 1995/114). In October 1995, working group 5 was officially formed to carry out the task of preparing a cross reference between the relevant sections of these standards and to analyse the differences on selected subjects. The goal at that time was to prepare a Technical Report which would provide reference information to assist national committees when reviewing and revising individual standards which may initiate a gradual convergence of the technical requirements. In 1996, the study was expanded to include the Korean safety standard.

Subsequently at the 2007 plenary meeting of ISO/TC 178, it was agreed to start the update in accordance with Resolution 190/2001. However, it was also agreed only to restrict the comparison to the American, European, and Japanese safety codes. That work was completed after six meetings in 2012.

The content of this Technical Report is based on the information provided by the WG 5 members acting in personal capacity.

This Technical Report is intended to aid standards writers in developing their safety requirements and to help standards users understand the basis for the requirements as they are applied throughout the world.

This Technical Report is not intended to replace existing safety standards which may have been updated. Conclusions are arrived at in some cases, but only where is unanimity amongst the various experts. In other cases, the reasons for the divergent views are expressed.

This Technical Report is to be read in conjunction with the various safety standards. Unless approved by the relevant standard writing organizations, the information contained in this Technical Report does not necessarily represent the opinions of these standards writing organizations (see [Annex B](#) for references).

The Technical Report was done with EN 115-1:2008 and its Amendment A1:2010 as a reference document shown as the only one in its normal sequence. All other codes are not in their normal sequence and logical order. They are structured differently to EN 115-1. The result incorrectly leaves the impression of incompleteness of these standards. These standards in their original structure inclusive of their references to other standards and requirements are however complete.



# Comparison of worldwide escalator and moving walk safety standards —

## Part 2: Abbreviated comparison and comments

### 1 Scope

This part of ISO/TR 14799 consists of a comparison of the requirements of selected topics as covered by the following worldwide safety standards (excluding local deviations):

- a) Europe (CEN) – EN 115-1, *Safety of escalators and moving walks — Part 1: Construction and installation* (Edition 2010, including Amendment 1);
- b) North America - ASME A17.1/CSA B44-2010, *Safety Code for Elevators and Escalators*;
- c) Japan – Safety requirements mainly comprised of Building Standard Law Enforcement Order (BSLJ-EO), Notifications of Ministry of Construction (MOC-N), and Japan Elevator Association Standard (JEAS).

It is to be noted that in addition to the above listed standards and other regulations, escalators and moving walks may be required to conform to the requirements of other standards, as appropriate. Where ISO/TC 178 was aware of these standards, they are mentioned in [Annex B](#).

### 2 Acronyms, abbreviated designations, and terminology

#### 2.1 Acronyms and abbreviated designations

The following acronyms and abbreviated designations are used by the codes compared when making reference to regulations and organizations.

ANSI	American National Standards Institute
ASME	American Society of Mechanical Engineers
BSLJ	The Building Standard Law of Japan
BSLJ-EO	The Building Standard Law Enforcement Order (Japan)
CEN/CENELEC	Comité Européen de Normalization (European Committee for Standardization)
CIRA	Commission Internationale pour la Réglementation des Ascenseurs et Monte-charge
CSA	Canadian Standards Association
EN	European Norm (standard)
EUIL-MO	Electrical Utilities Industry Law - Ministerial Ordinance of technical standards for electrical equipment
EXP	Explanation/Interpretation of BSLJ-EO, MOC-N (Japan)

IEC	International Electrotechnical Commission
ISO	International Standardization Organization
JEAC	Japan Electrical Association Code
JEAS	Japan Elevator Association Standard
JIS	Japanese Industrial Standard
MOC-N	Notifications of the Ministry of Construction (Japan)
NEC	National Electrical Code (USA)
NFPA	National Fire Protection Association (USA)
OSHA	Occupational Safety and Health Administration (USA)

## 2.2 Terminology (list of terms used in the codes)

Table 1 shows those terms which are used differently for the same item in the standards dealt with. Definitions in the Japanese standard are based on unofficial translation, whereas the terms in European and American codes are official language.

The items in parenthesis reference the clauses where the terms are used in the various standards.

**Table 1 — Differences in terminology (list of terms used in the codes)**

EN 115-1 (Europe)	A17.1/B44 (North America)	Japanese Codes
Auxiliary brake (5.4.2.2)	Main drive shaft brake (6.1.5.3.2)	Main drive shaft brake
Balustrade decking (3.1.3, 5.5.2.2)	High deck balustrades (6.1.6.3.1, 6.2.3.3.7, 6.2.6.3.1)	Deck board
Balustrade exterior panelling (mod)	Exterior panel	Exterior panel
Balustrade interior panelling (mod)	Interior panel (6.1.3.3.1, 6.2.3.3.4)	Interior panel
Brake load (3.1.4)	Brake rated load (6.1.3.9.3, 6.2.3.10.3, 6.2.5.3.1, 6.2.5.3.2)	
Criss-cross (A.2.3, A.2.4)	6.1.3.3.13	Criss-cross
Safety factor (5.4.1.3.2, 5.4.3.2)	Design factor of safety (3.6.1, 3.6.4)	Safety factor
Height above the steps (A.2.1)	Head-room (8.10.4.1.1)	Height above the steps
Inclination (3.1.1)	Slope/inclination (6.2.3.1, 6.2.3.7, 6.2.3.9.1)	
Inspection cover and floor plate (5.2.4)	Access door/plate (US) (6.2.7.3.3)	
Lower inner decking (5.5.2.6)	Low-deck interior (802.3d)	
Multiplex chain (5.4.1.3.1, 5.4.2.2.1)	Multi-strand chain	
Not easy to ignite (0.5.1)	Non/limited combustible (6.1.2.1, 6.2.2.1)	
Moving walk	Moving walk	Moving (side) walk
Rated load <sup>a</sup>	Rated load <sup>a</sup> (6.2.3.10)	Rated load <sup>a</sup>
Rated speed <sup>a</sup> (3.6)	Rated speed <sup>a</sup> (6.1.4, 6.2.4)	Rated speed <sup>a</sup>
Skirting (3.1.23, 5.5.3)	Skirt (panel) (6.1.3.3.6, 6.2.3.3.6)	Skirt guard (panel)

<sup>a</sup> Definitions vary from code to code (see Annexes); terms in European, American, and Australian code are official terms.



Table 1 (continued)

EN 115-1 (Europe)	A17.1/B44 (North America)	Japanese Codes
Structural load	Structural rated load (6.1.3.9.1, 6.2.3.10.1)	
Supporting structure (5.2)	Truss (6.1.2, 6.1.3.7, 6.1.3.10.1, 6.2.3.11.1, 6.2.7.1.2)	Truss
Supporting structure (of the combs) (8.3.2.4, 8.3.2.6, 16.2.1.1.1)	Comb plate (6.1.6.3.13, 6.2.6.3.11, 6.2.8.3), access plate (6.1.7.3, 6.2.7.3)	Comb plate
Maximum capacity (Annex H.1)		
	Machinery rated load (6.1.3.9.2, 6.2.3.10.2)	
	Conventional/modular moving walk (6.1.3.9.2, 6.1.3.9.3, 6.1.3.10)	
	Skirt obstruction device (6.1.6.3.6)	Skirt guard switch [JEAS-406F (draft), 2.1] MOC-N (no. 1424-2000), 2(d)
	Skirtless balustrade (6.2.3.3.5)	
Horizontal movement (5.7.2.1)	Flat step (6.1.3.6.5)	(Flat step)
<sup>a</sup> Definitions vary from code to code (see Annexes); terms in European, American, and Australian code are official terms.		

### 3 Basis for escalator and moving walk safety standards

#### 3.1 Historical origin and development of standards

##### 3.1.1 European Standard EN 115-1

###### 3.1.1.1 Why do we have EN 115-1?

The ever increasing number of escalators put in operation in Europe after the second world war required the drawing-up of guidelines for models and safety for escalators, especially as not all European countries had their own standard or national regulation for escalators.

So in the early 1960s, specialists/experts from seven European countries joined together and founded the “Commission Internationale pour la Réglementation des Ascenseurs et Monte-charge (CIRA)”. The CIRA draft for escalators was produced in June 1972 containing safety guidelines for escalators to protect persons and objects against possible accidents and injury.

The Technical Committee CEN/TC 10 “lifts” and established a working group in June 1974 with the request to prepare a draft European Standard for escalators and moving walks.

The convenorship of this work group was initially given to a member of the German delegation. In December 1974, the German convenor distributed a first proposal for the construction and installation of escalators founded on the CIRA guidelines, which after careful examination through the CEN/TC 10, was submitted to all member countries of the CEN for consideration in June 1977.

It should be noted that the EC Committee BTS2 gave the CEN a mandate for drawing up this part of ISO/TR 14799 in 1976.

Finally, following a second and a third draft, the final edition of EN 115 was prepared and accepted by CEN on 3rd January 1995 (firstly amended January 1998).

Considering that EN 115:1995 had given rise to requests for interpretation and this standard did not fully comply with EN 414 (today CEN Guide 414 “Safety of machinery — Rules for the drafting and

presentation of safety standards”), CEN/TC 10 asked its Working Group 2 to revise EN 115:1995. This task was completed by CEN/TC 10 in 2007 when the final draft of EN 115-1 was available. An Amendment 1 was published in 2010.

According to the Internal Regulations of CEN/ CENELEC, the CEN members are bound to give this EN 115-1 the status of a National Standard without any national deviations.

The following countries are CEN Members:

Austria, Belgium, Bulgaria, Cyprus, Czech Republic, Denmark, Estonia, Finland, France, Germany, Greece, Hungary, Iceland, Ireland, Italy, Latvia, Lithuania, Luxembourg, Malta, Netherlands, Norway, Poland, Portugal, Romania, Slovakia, Slovenia, Spain, Sweden, Switzerland, and the United Kingdom.

### **3.1.1.2 How did we get EN 115-1?**

The drawing up of the harmonized European Standard removed the technical trade restraints on the escalators and moving walks within the CEN countries listed above. The safety level of the CIRA Directives Edition June 1972 and the existing national regulations or standards of the CEN Member States essentially became reference documents which illustrate how the new standard was derived.

Therefore, all CEN members are bound to follow the CEN/CENELEC requirements and all national standards for escalators and moving walks are superseded by the harmonized EN 115-1 standard.

### **3.1.1.3 What is the code (law, standard, requirement)?**

The purpose of EN 115 is to define minimum safety requirements in order to reduce the possibility of accidents on escalators and moving walks.

The harmonized standard is essentially a method of demonstrating compliance with the essential safety requirements of the machinery directive which is embodied in the laws of each country member of CEN/CENELEC and therefore, demonstrates compliance with the laws of the member states.

### **3.1.1.4 Is EN 115-1 a compulsory standard?**

Some exceptions are possible (such as sections 0.3 and 1.3).

### **3.1.1.5 Is EN 115-1 a technical description, a requirement, or a recommendation?**

Compliance with EN 115-1 is one way to satisfy the requirements of the European Machinery Directive.

### **3.1.1.6 Is EN 115-1 a performance or a design standard?**

EN 115-1 has to be considered as a minimum requirement for safe operation of escalators and moving walks.

## **3.1.2 North American Standard A17.1/B44**

### **3.1.2.1 Why do we have A17.1/B44?**

A17.1/B44 is intended to enhance public health and safety. It serves as the basis for state, municipal, and other jurisdictional authorities in drafting regulations governing the installation, testing, inspection, maintenance, alteration, and repair of elevators, dumbwaiters, escalators, moving walks, material lifts with automatic transfer devices, wheelchair lifts, and stairway chair lifts. It is also intended as a standard reference of safety requirements for the guidance of architects, engineers, insurance companies, manufacturers, and contractors, and as a standard of safety practices for owners and managements of structures where equipment covered in the scope of the code is used.

### 3.1.2.2 How did we get A17.1/B44?

The use of elevators and escalators began to rapidly expand in the early 1900s as larger and taller buildings were transforming American cities into high rise population centres. With the growth of the elevator industry came a proliferation of new manufacturers and maintenance organizations that lacked the knowledge and background of the industry developers. They often, because of this lack of experience, failed to understand or enforce safe practices in the work they performed.

It became apparent that in order for these cities, with their high-rise buildings to remain viable, the public had to have unwavering faith in the safety of the elevators that made these buildings usable. A safety code developed by experts in the field of vertical transportation would help develop this public confidence.

In 1915, ASME assembled a committee of engineers who were knowledgeable about elevators and charged them with developing a set of standards for elevator manufacturers, architects, consulting engineers, insurance inspectors, and building owners. The committee recognized the harmful influence of wear, rough usage, and atmospheric conditions under which elevator apparatus must operate, particularly on door locks, interlocks, and electrical contacts.

This effort resulted in the first edition of the A17.1 code being developed in 1921. New editions are periodically published which in recent years has been every third year. An addendum is published annually between editions.

As a result of a joint effort by the CSA B44 Technical Committee on the Elevator Safety Code and the ASME A17 Committee on Elevators and Escalators, harmonization of the provisions of CSA B44 and ASME A17.1 was completed and published as ASME A17.1/CSA B44 in 2007. The 2nd edition of ASME A17.1/CSA B44 was published as ASME A17.1-2010/CSA B44-10 in 2010.

### 3.1.2.3 What is the code (law, standard, requirement)?

The A17.1/B44 Safety Code for Elevators and Escalators is a voluntary reference standard that is used by people and organizations involved in the industry. Developed by a consensus of experts in the industry, it is used to guide them in maintaining a high level of safety in their respective functions.

After it is developed by the ASME under the auspices and consensus procedures established by ANSI, it becomes an American National Standard.

### 3.1.2.4 Is A17.1/B44 a compulsory standard?

As published, A17.1/B44 is a voluntary standard. It is used by authorities having jurisdiction as a basis for the code they enforce and becomes law when the governing legislative body over their jurisdiction adopts it.

### 3.1.2.5 Is A17.1/B44 a technical description, a requirement, or a recommendation?

A17.1/B44 presents most of its requirements as mandatory when following the standard. However, some rules may be in the form of a permissive recommendation.

### 3.1.2.6 Is A17.1/B44 a performance or a design standard?

The A17.1/B44 code is developed as a performance standard under the procedures established by the ASME and the CSA. Due to the unique nature of the industry, some rules are of a design nature, but efforts are continually underway to replace them with performance language.

## 3.1.3 The Japanese codes

### 3.1.3.1 Why do we have Japanese codes?

The Japanese codes are established to protect life, health, and property of the nation, and thereby, to contribute to promoting public welfare.

### 3.1.3.2 How did we get Japanese codes?

Japanese codes are comprised of the following laws and standards.

#### 3.1.3.2.1 The Building Standard Law of Japan (BSLJ)

##### 3.1.3.2.1.1 Enactment of the law

This law was enacted in May 1950 and has been revised several times.

##### 3.1.3.2.1.2 Purpose of this law

The purpose of the law is to safeguard the life, health, and property of people by providing minimum standards concerning the site, construction, equipment and use of buildings, and thereby, to contribute to the furtherance of the public welfare.

##### 3.1.3.2.1.3 Equipment of buildings

Equipment of buildings are electricity, gas, water supply, drain, ventilation, heating, air-conditioning, fire extinguishing, smoke removal, or equipment of dirt disposal, chimneys, elevatory equipment, and lightning conductors.

##### 3.1.3.2.1.4 Elevatory equipment (article 36)

Concerning elevatory equipments, technical standards which are required for safety, fire prevention, and appropriate sanitation are specified by cabinet order.

#### 3.1.3.2.2 The Building Standard Law Enforcement Order (BSLJ-EO)

3.1.4.2.2.1 This order was established in November 1950 and has been revised several times.

3.1.4.2.2.2 Construction of escalators is described in Article 129-12.

3.1.4.2.2.3 Structural calculation for escalators is described in Article 129-12.

#### 3.1.3.2.3 Notifications of the Ministry of Construction (MOC-N)

The notifications describe an indistinct part of BSLJ and BSLJ-EO.

The following notifications relate to the escalators and moving walks:

- no.1413: Requirements for over 30° inclination escalator, over 1,1 m step/pallet width and accelerate moving walk;
- no.1417: Requirements for clearance between step and skirt panel, vertical deflector, and nominal speed;
- no.1418: Requirement for structural calculation;
- no.1424: Requirements for fault detection and stopping distance.

#### 3.1.3.2.4 Japanese Industrial Standard (JIS)

3.1.3.2.4.1 This standard was established by Ministry of International Trade and Industry in 1949. JIS A 4302 (inspection standard of elevator, escalator, and dumbwaiter) has been published in 1964 as the first edition and revised several times.

**3.1.3.2.4.2** This standard stipulates inspection items, inspection apparatus method, and standard of judgement in order to inspect the safety concerning traction type elevator, escalator, moving walk, and electrical dumbwaiter installed in building, structure, etc.

NOTE Moving walk is treated therein as escalator of special construction.

**3.1.3.2.4.3** Escalators and moving walks are described in [4.4](#).

### **3.1.3.2.5 Japan Elevator Association Standard (JEAS)**

**3.1.3.2.5.1** This standard was established in June 1974 and has been revised several times.

**3.1.3.2.5.2** The purpose of this standard is to stipulate the universal standard for elevator and escalator industry unifying the correct application and method of laws, JIS, etc. and thereby, to facilitate to the negotiation with the competent authorities.

**3.1.3.2.5.3** It is recommended that some of the content stipulated be enacted as law or incorporated into JIS.

### **3.1.3.2.6 Electrical Utilities Industry Law Ministerial Ordinance of Technical Standards for Electrical Equipment (EUIL-MO)**

**3.1.3.2.6.1** The standard was established in July 1965 as the Ministerial Ordinance of the Ministry of International Trade and Industry and shall be revised if deemed necessary.

**3.1.3.2.6.2** The purpose of the standard is to safeguard the applicable electrical apparatus.

**3.1.3.2.6.3** This stipulates the facility standard where enclosed electrical apparatus both for commercial and home use.

### **3.1.3.2.7 Japan Electrical Association Code (JEAC)**

**3.1.3.2.7.1** This code was established in November 1963 and shall be revised if deemed necessary.

**3.1.3.2.7.2** The purpose of this code is to safeguard the applicable electrical apparatus and contribute to the convenient electricity use.

**3.1.3.2.7.3** The code applies to electrical apparatus both for commercial and home use; it does not stipulate anything concerning facilities of vessels, vehicles, or airplanes.

**3.1.3.2.7.4** The code stipulates the technical matters subjected to follow so that no humans or animals may be exposed to any hazard by electrical apparatus or products.

### **3.1.3.3 What is the code (law, standard, requirement)?**

The codes consist of four kinds of laws (BSLJ, BSLJ-EO, MOC-N, and EUIL-MO) and three kinds of standards (JIS, JEAS, and JEAC).

### **3.1.3.4 Are the Japanese codes compulsory standards?**

The Japanese codes are compulsory standards.

**3.1.3.5 Are the Japanese codes a technical description, a requirement, or a recommendation?**

The Japanese codes are technical descriptions, requirements, and recommendations.

**3.1.3.6 Are the Japanese codes performance or design standards?**

The Japanese codes are considered as performances and design standards.

**3.2 General — Technical basis and structure of standards**

NOTE Committee’s comments are shown in italics.

**Table 2 — Technical basis and structure of standard**

EN 115-1 (Europe)	A17.1/B44 (North America)	Japanese Codes
<p><b>5.9:</b> Material not easy to ignite  <b>Remark:</b> “Free of PVC” is nowhere required; details to be defined by national building codes</p>	<p>Requirements in <b>6.1.1, 1 6.1.2.1 and 6.2.1.1, 6.2.2.1</b> (non/or limited combustible)  <b>6.1.3.5.1 (a) and (b)/6.2.3.5.5 (a) and (b)</b> Material, type, and fire rating</p>	<p><b>BSLJ; Art. 34</b>  <b>MOC-N (No. 1418-2000), 2(2)(a) and 2(2)(b)</b></p>
<p><i>5.9: A17.1/B44 Defines materials and parts of the machine that have to be protected. The Japanese regulation is similar to EN 115-1. The intention of all regulations is more or less the same. They refer to specific tests and the specification for material shall be defined.</i></p> <p><i>AGREED UPON: Automatic fire extinguisher systems should not be used. Furthermore, any sprinkler head should not reduce maintenance space (no comment of A17.1/B44).</i></p>		
<b>5.10</b> Transportation	No requirement	No requirement
<p><b>5.10</b>  <i>Comment: Only EN 115-1 5 defines rules for transportation. This is a legal requirement coming from the European Machinery Directive.</i></p>		
<b>Introduction (11):</b> Special environmental conditions	<b>Rules 6.1.8.1, 6.1.8.2, 6.1.8.3 and 6.2.8.1, 6.2.8.2, 6.2.8.3</b>	<b>JEAS-520</b> Installation for outdoor condition
<p><i>Introduction (11) A17.1/B44 requires a roof and secure foothold. The Japanese regulation has corrosion aspects in mind.</i></p>		
No note	<p>No life performance requirements  <b>Remark:</b> There is an industry standard for performance requirements</p>	No note
<b>1 Scope</b>		
<b>1.1 (1):</b> Standard is applicable on new installation	Like EN 115-1 and additionally for operation, maintenance and alteration	<b>BSLJ ; Art. 3, 2</b> for escalators and special constructions
<b>1.2:</b> Seismic activity not covered	No note	<b>MOC-N (No.541-2009)</b>
<b>1.3:</b> Recommendation for retrospective	<b>A17.3</b> Code applies to existing installations	<b>BSLJ; Art. 3, 3(3)</b>
<p><b>Clause 1:</b>  <i>AGREED UPON: The design and operation of new escalators (moving walk) is covered as well as maintenance. Existing installations, installation procedures, code deviations, testing, inspection, repair, and alteration vary in different codes and are not part of the agreed upon points.</i></p>		
<b>1.1 (2)</b> Respect reasonably foreseeable misuse	No note	No note

Table 2 (continued)

EN 115-1 (Europe)	A17.1/B44 (North America)	Japanese Codes
<b>1.1 (2)</b> <i>Customer specifications and life of the equipment are all part of the design and commercial requirements and are not part of A17.1/B44.</i>		
<i>Concerning imprudent act of the user, there are no similar statements in A17.1/B44 since this is the responsibility of the designer. It should be noted that there is a legal responsibility in the USA and in the European Union's Directives for the designer to compensate for reasonable foreseeable abuse in the design of the equipment.</i>		
<b>Annex I:</b> Misuse with trolleys	Escalators and moving walks only for passenger transport	<b>MOC-N (No. 1417-2000) 1, EXP. 1 and EXP. (notice of designing) 2,</b> for wheelchair escalator
<b>Annex I</b> <i>The use of escalators by other than ambulatory passengers is only permitted by EN 115-1. Such use is only permitted under special circumstances and modifications as agreed between the manufacturer of the escalator and the transportation means and the owner of the escalator. Moving walks as stipulated in the A17.1/B44 may only be used by passengers.</i>		
<b>(1.4)</b>	<b>6.1.3.14, 6.2.3.17</b> Components not in connection with escalator/moving walk not permitted in them	-
<b>2 Normative references</b>		
<b>2:</b> See Annex B.1	See Annex B.2	See Annex B.4

### 3.3 Definitions

NOTE Committee's comments are shown in italics.

**AGREED UPON:** *Instead of "passenger conveyor" the term "moving walk" shall be used.*

**FUNDAMENTAL DIFFERENCES:**

— *A17.1/B44 uses definitions to clarify unique terminology used within the code/rules.*

**AGREED UPON:** *Definitions have to clarify specific escalator/moving walk terminology without introducing extra requirements. If rules are self-explanatory as to the meaning of their headings, additional definitions are not required.*

Table 3 — Definitions

EN 115-1 (Europe)	A17.1/B44 (North America)	Japanese Codes
<b>3.1.1:</b> Definition of angle of inclination (for maximum, see 10)	No definition, slope/inclination is used	MOC-N (No. 1413-2000), EXP.2(1)
<b>3.1.1</b>		
<b>AGREED UPON:</b> <i>The angle of inclination is the angle made between the line the passenger travels between transitions and the horizontal measured along the centre line of the steps.</i>		
<b>3.1.3</b> Definition <b>balustrade decking</b> (see Figure 3).	High deck interior, high deck exterior, low deck exterior See <b>Appendix I, Fig.I-3</b>	<b>BSLJ-EO Figure 129-5, 129-7 and 129-8</b> Deck board
<b>3.1.3</b> <i>The A17.1/B44 definitions for high deck exterior/interior and low deck exterior are more precisely than the one for balustrade decking in EN 115-1.</i>		
<b>FUNDAMENTAL DIFFERENCES:</b> <i>A17.1/B44 prevents any change in width.</i>		
<b>3.1.5:</b> Definition of comb	Section 1.3, definition of comb	No definition
<b>3.1.5</b>		
<b>AGREED UPON:</b> <i>A comb is a pronged section at each landing that meshes with the grooves in the passenger carrying surface. A comb plate is a platform at each landing to which the combs are attached.</i>		
<b>3.1.8:</b> Definition of escalator	Conventional and modular escalator	<b>BSLJ-EO 129-3, EXP. 1(2)</b>

Table 3 (continued)

EN 115-1 (Europe)	A17.1/B44 (North America)	Japanese Codes
<p><b>3.1.8</b>  <b>AGREED UPON:</b> An escalator is a power-driven, inclined, continuous stairway used for raising or lowering passengers.</p>		
<p><b>3.1.9</b> Definition exterior panel                      (see Figure 3)</p>	<p>Exterior panel                      See <b>Appendix I, Fig.I-3</b></p>	<p>Exterior panel  <b>BSLJ-EO Figure 129-5, 129-7 and 129-8</b></p>
<p><b>3.1.9</b>  <b>AGREED UPON:</b> The exterior panel is a panel enclosing the exterior sides of the escalator or moving walk.</p>		
<p><b>3.1.11:</b> Definition of handrail</p>	<p>No definition</p>	<p>No definition</p>
<p><b>3.1.11</b>  <b>AGREED UPON:</b> A handrail is a power-driven moving rail for passengers to grip while using the escalator or moving walk.</p>		
<p><b>3.1.12</b> Definition interior panel                      (see Figure 3)</p>	<p>Interior panel (see <b>Appendix I, Fig. I-3 for escalators only</b>)</p>	<p><b>BSLJ-EO Figure 129-5, 129-7 and 129-8</b>                      Interior panel</p>
<p><b>3.1.12</b>  <b>AGREED UPON:</b> The interior panel is a panel located between the skirting or lower interior decking and the handrail support profile or upper inner decking.</p>		
<p><b>3.1.13 a</b> Definition lower inner decking (see Figure 3)</p>	<p>Low-deck interior (see <b>Nonmandatory Appendix I, Fig. I-1</b>)</p>	<p><b>BSLJ-EO Figure 129-5, 129-7 and 129-8</b></p>
<p><b>3.1.13 a</b>  <b>AGREED UPON:</b> Lower inner decking is a profile that connects the skirting with balustrade interior panel when they do not meet at a common point.</p>		
<p><b>3.1.16:</b> Definition of maximum capacity</p>	<p>Rated load is mentioned, no definition of maximum capacity</p>	<p><b>BSLJ-EO; Art. 129-12, EXP. 1(4)</b></p>
<p><b>3.1.16</b> Only EN 115-1 uses the term “theoretical capacity”. This theoretical value will never be reached (the real limit is 6,800 persons/h) and depends on the behaviour of the user.  <b>AGREED UPON:</b> Real load conditions have to be defined. Definitions like theoretical capacity are not related to general safety codes.                      NOTE: the results of EN 115-1 investigation shows for a step width of 1 000 mm:                      - v = 0,7 m/s up max. 6 800 pers/h counted</p>		
<p><b>3.1.17:</b> Definition of moving walk</p>	<p>The description of moving walks includes in <b>Section 1.3</b> six different types</p>	<p><b>BSLJ-EO 129-3, EXP. 1(2)</b></p>
<p><b>3.1.17</b>  <b>AGREED UPON:</b> A moving walk is a power-driven installation for the conveyance of passengers in which the passenger-carrying surface remains parallel to its direction of motion and is uninterrupted</p>		



<b>3.1.18</b> Definition <b>newel</b>	Newel (see <b>Appendix I, Fig. I-3</b> )	Not defined
<b>3.1.18</b> <i>AGREED UPON: The newel is the end of the balustrade. EN 115-1.</i>		
<b>3.1.19:</b> Definition of nominal speed means: no load condition	Rated speed means full load condition	<b>MSLJ-EO, 129-12 1(5)</b> No condition for load in upward direction
<b>3.1.19</b> <i>FUNDAMENTAL DIFFERENCES: Rated speed is defined differently in various standards and effects many code requirements fundamentally.</i> <i>The North American and Japanese code define the rated speed as the speed at which the escalator can lift the rated load. Rated load is the load that the escalator is designed to lift.</i> <i>The reasons for the Europeans to do so was the possibility to carry out practical measurements.</i>		
<b>3.1.25</b> Definition <b>skirting</b> See Figure 3	Skirt panel (see <b>Appendix I, Fig. I-3, I-8</b> ) Not defined for moving walks	Skirt guard panel <b>BSLJ-EO Figure 129-5, 129-7 and 129-8</b>
<b>3.1.25</b> <i>AGREED UPON: The skirting is a vertical part of the balustrade interfacing with the outer edge of the escalator steps and moving walk treadway.</i>		
<b>3.1.26:</b> Definition of skirt deflector	No definition	No definition
<b>3.1.26</b> <i>There is no need for discussion.</i>		
<b>(3.31)</b> No definition	Definition controller	No definition
<b>(3.32)</b> No definition	Definition driving machine	No definition
<b>(3.33)</b> No definition	Definition flat steps	No definition
<b>(3.34)</b> No definition	Definition landing	No definition
<b>(3.35)</b> No definition	Definition pallet, moving walk	No definition
<b>(3.36)</b> No definition	Definition slope, moving walk	No definition
<b>(3.37)</b> No definition	Travel (rise)	No definition
<b>(3.38)</b> No definition	Definition treadway, moving walk	No definition
<b>(3.39)</b> No definition	Definition width escalator/moving walk	No definition

## 4 Selected topics

### 4.1 General

This comparison laid down in [Tables 4 to 15](#) is between EN 115-1 and the rules in A17.1/B44 and the Japanese code. There are other standards (see listed in Scope) in the countries concerned that have requirements not shown in the escalator/moving walk standards compared, but are addressing some requirements in EN 115-1.

Significant hazards, hazardous situations, and events identified for escalators and moving walks and which require action to eliminate or reduce the risk are covered by this comparison. In addition, for relevant but not significant hazards which are not dealt with by these standards to be compared, the principles of ISO 12100 apply.

When symbols are used to compare principal dimensions (e.g.  $L_1$ ,  $b_8$ ,  $h_6$ , etc.), always those of EN 115-1, Figures 2, 3, 5, and 8 (see [Annex A](#)) are used independent of the designation in other standards.

NOTE 1 EN 115-1 clause numbers in brackets serve only as a reference point. They do not exist in the real EN 115.

NOTE 2 Committee's comments are shown in italics.

## 4.2 Enclosure, inspection doors

**Table 4 — Supporting structure (truss) and enclosure**

EN 115-1 (Europe)	A17.1/B44 (North America)	Japanese Codes
5.2.1.1: Complete enclosure	See 6.1.2.1/6.2.2.1 and 6.1.3.3.1 (b)/6.2.3.3.1 (b) <b>New Rule:</b> 6.1.3.6.6/6.2.3.8.5 floor opening protection adjacent to escalator	
<p><b>5.2.1.1</b> <i>FUNDAMENTAL DIFFERENCES: A17.1/B44 requires that sides and undersides of a truss shall be enclosed with materials defined as either non combustibile or limited combustibile to protect both the escalator or the environment.</i> <i>AGREED UPON: The truss sides and undersides should be covered with material that will contain combustion within the truss. These materials are determined by individual building or fire codes in each country.</i></p>		
5.2.1.2: Strength and rigidity of enclosure	Not mentioned, defined in building code	No comment
5.2.1.2: Adequate mechanical strength and rigidity needs detailed definition and performance criteria.		
5.2.1.3: Omission of enclosure	No content	No note
5.2.1.3 The omission of enclosure is only mentioned in EN 115-1. The protection in case of fire should be in accordance to the agreed upon point to 5.2.1.1.		
5.2.1.4: Cleaning of underside enclosure	8.6.8.13/8.6.9.11 like EN 115 and cleaning periods are defined	No comment
5.2.1.5 Apertures for ventilation	6.1.2.1/6.2.2.1	No requirement
<p><b>5.2.1.5</b> <i>AGREED UPON: Escalators/moving walks should be effectively ventilated to dissipate the heat generated. Apertures should not enable contact with moving parts.</i></p>		

<p><b>5.2.1.6</b> Requirement for safety device</p>	<p><b>6.1.7.3.3/6.2.7.3.3</b> is close to that requirement</p>	<p>No requirement</p>
<p><b>5.2.2</b> Angle of inclination <math>\alpha \leq 30^\circ</math>  <math>\alpha \leq 35^\circ</math>, if rise <math>\leq 6</math> m and <math>v \leq 0,5</math> m/s  Moving walks: <math>\alpha \leq 12^\circ</math></p>	<p><b>6.1.3.1</b> <math>\alpha \leq 30^\circ</math>  <b>6.2.3.1</b> <math>\alpha \leq 12^\circ</math> moving walks and upper and lower landing <math>\alpha \leq 3^\circ</math> within 900 mm</p>	<p><b>BSLJ-EO Art.129-12 1.(2)</b>  <math>\alpha \leq 30^\circ</math>  Moving walks: <math>\alpha \leq 15^\circ</math>  <b>BSLJ-EO; Art. 129-12 EXP. 1 (2)</b>  <b>(1)(a)</b> <math>\alpha \leq 35^\circ</math>, if rise <math>\leq 6</math> m and <math>v \leq 0,5</math> m/s and <math>y_1 \geq 35</math> cm and minimum two flat steps  [MOC-N (No.1413-2000) 2-1]  <b>(2)(a)</b> <math>\alpha \leq 4^\circ</math> if step width <math>1,1 &lt; z_1 \leq 1,6</math> m  <b>(3)(e)</b> The escalator of which speed varies in halfway of travel  It shall conform to the construction specified as follows.  (e) Slope of the escalator shall be equal to or less than <math>4^\circ</math> at the position where the speed of step varies and shall be equal to or less than <math>8^\circ</math> at the position other than the part mentioned above.</p>
<p><b>5.2.2:</b>  - <b>Escalators:</b> A17.1/B44 specifies an angle of inclination less or equal to <math>30^\circ</math>. EN 115-1 and Japan permit an angle up to <math>35^\circ</math> under special conditions (EN 115-1 and Japan: Rise max. 6 m, speed max. 0,5 m/s).  - <b>Moving walks:</b>  <b>Historical background:</b> EN 115-1 permits inclined moving walks in order to support the use of trolleys (see Annex I.2).</p>		
<p><b>5.2.3</b> Machinery spaces  Requirements on authorization</p>	<p><b>8.1.3</b> Authorized personnel</p>	<p>No requirement</p>
<p><b>5.2.3</b> EN 115-1 and A17.1/B44 are defining specific requirements for accessing inside truss and separate outside escalator machinery spaces (separate machine rooms).</p>		
<p><b>5.2.4 (1)</b> Inspection/trap doors for inspection and maintenance requirement for safety switch</p>	<p>Reasonable access to interior is required similarly  <b>6.1.7.3/6.2.7.3</b> additional requirement for mechanical retention of covers</p>	<p>No requirement</p>
<p><b>5.2.4 (1)</b> Inspection and trapdoors (see Figure 1 for explanation) are part of the enclosure. The general access to the interior is treated in 6.2 and it is required for maintenance and inspection.  <b>RECOMMENDATION:</b> Stop switches should be located in these areas which when activated prevent the operation of the escalator or moving walk.</p>		
<p><b>5.2.4 (2), (3)</b> closing/opening requirements for inspection/trap doors</p>	<p>Same intention in 6.1.7.3.2/6.2.7.3.2 and <b>6.1.7.3.3/6.2.7.3.3</b></p>	<p>No requirement</p>
<p><b>5.2.4 (2),(3)</b> (see also Annex A.3)  <b>FUNDAMENTAL DIFFERENCES:</b> A17.1/B44 and EN 115-1 require to lock the access door with a key. In A17.1/B44 the key shall be removed only when in the locked position. EN 115-1 requires to open the access door from the inside even when the door is locked.</p>		

**Table 4** (continued)

<p><b>5.2.4 (4)</b> Inspection door, material same as for enclosure</p>	<p><b>(6.1.7.3.1/6.2.7.3.1)</b></p>	<p>Not defined</p>
<p><b>5.2.4 (4)</b> (defined in Annex A.3 "Machinery spaces outside truss")</p>		
<p><b>5.2.5</b> Supporting structure loads                      5 000 N/m<sup>2</sup>                      Deflection: <math>l_1/750</math>                      Rated Load:                      1 000 mm width: 5 000 N/m                      800 mm width: 4 000 N/m                      600 mm width: 3 000 N/m                      Materials of supporting structure non-combustible</p>	<p><b>6.1.3.9</b> Structural and machinery rated load <i>different</i>                      Structural (kg) = 0,27 (W+203)A                      Machinery (kg) = 0,21 (W+203)B<sub>1</sub>                      Structural:                      1 000 mm: 3 185 N/m                      800 mm: 2 656 N/m                      600 mm: 2 126 N/m                      Machinery:                      1 000 mm: 2 477 N/m                      800 mm: 2 066 N/m                      600 mm: 1 656 N/m                      Safety factor acc. to 6.1.3.10</p>	<p><b>BSLJ-EO Art 129-12 (3)</b>                      Supporting structure load  <math>P = 2\ 600\ \text{N/m}^2</math>  <b>MOC N (No. 1418-2000), 2(2)</b>                      Safety factor at normal operation is three against breaking point.                      Safety factor when safety device is actuated is two against breaking point  <math>P = 2,600A</math>  <b>JEAS-1003B</b>, Escalator specifications.  <b>JEAS-1004B</b>, Structural calculation for escalator.</p>
<p><b>5.2.5</b> For moving walks, see above</p>	<p><b>6.2.3.10 Structural and machinery rated load different</b>                      Structural (kg) = 0,49 (W)A                      Machinery (kg) = 0,37 (W)C<sub>1</sub>                      Safety factor acc. to 902,12  <b>6.2.3.9 Supporting structure</b></p>	<p>See above</p>
<p><b>5.2.5</b> (see Figure 5)  <b>Fundamental differences:</b>                      - A specific deflection of the truss (supporting structure) is required by EN 115-1;                      - The machinery load, used for the calculation of the driving machine and the power transmission components, is clearly defined in A17.1/B44; EN 115-1 and JIS are using the rated load for the calculation of the power transmission components.</p>		
<p><b>(5.2.6)</b> Not mentioned</p>	<p><b>6.1.3.7 Truss or giders</b>                      - Retaining running gear                      - Retain released tension weights (if any)</p>	<p>Not mentioned</p>

## 4.3 Steps and pallets

Table 5 — Steps and pallets

EN 115-1 (Europe)	A17.1/B44 (North America)	Japanese Codes
<b>5.3 Step, pallets, belt</b>		
<b>5.3.1 General</b>		
<b>5.3.1 (1)</b> Step tread horizontally ( $\pm 1^\circ$ ) <b>5.3.1 (2)</b> Secure foothold defined	<b>6.1.3.5.1 (c)</b> The step supporting system shall be so designed so that the back of the step cannot tip upward more than 6 mm (0,25 in.) at any point. Request for secure foothold. <b>6.2.3.5.5.(c)</b> Request for secure foothold	No requirements
<b>5.3.1</b> <i>AGREED UPON: All steps treads should remain predominantly horizontal in the area accessible to passengers.</i>		
<b>(5.3.1.1)</b> No requirement	<b>6.1.3.5.1(a) and (b)/6.2.3.5.5 (a) and (b)</b> Material, type, and fire rating	No requirement
<b>(5.3.1.2)</b> No requirement	<b>6.1.3.5.8 Step Wheels/6.2.3.5.6 Pallet Wheels.</b> Where support wheels attached to the steps are not located within the width of the step, provision shall be made to prevent the step from falling into the escalator interior due to a loss of one or more of the support wheel assemblies.	No requirement
<b>(5.3.1.2)</b> <i>A17.1/B44 is the only code which requires measures to prevent steps from falling into the interior in case of roller and assembly failures.</i>		
<b>5.3.2 Dimensions</b>		
<b>5.3.2.1</b> Step width/pallet width <b>Figure 5</b> $0,58 \text{ m} \leq z_1 \leq 1,10 \text{ m}$ wider pallets permitted if inclination not more than $6^\circ$	$560 \text{ mm} \leq z_1 \leq 1\ 020 \text{ mm}$ <b>6.1.3.5.2</b> Moving walks <b>6.2.3.7</b> $560 \text{ mm} \leq z_1 \leq \text{maximum}$ , see Table <b>6.2.3.7</b>	<b>BSLJ-E0; Art. 129-12; 1 (4) and Exp. 1 (4);</b> not more than 1,10 m for escalators <b>MOC-N (No. 1413-2000; 2 (2)(c) and 2(3)(f))</b> For moving walks $z_1 \leq 1,6 \text{ m}$ for not more than $4^\circ$ $z_1 \leq 1,1 \text{ m}$ for more than $4^\circ$
<b>5.3.2.1</b> <i>No comment necessary</i>		
<b>5.3.2.2 Step treads and pallets</b> <b>5.3.2.2.1</b> Step height $x_1 \leq 0,24 \text{ m}$	$x_1 \leq 220 \text{ mm}$ <b>6.1.3.5.2</b>	No requirement
<b>5.3.2.2.1</b> <i>In Japan, there is no requirement for a step height to be defined.</i>		
<b>5.3.2.2.2</b> Step depth $y_1 \geq 0,38 \text{ m}$ <b>Figure 5</b>	$y_1 \geq 400 \text{ mm}$ <b>6.1.3.5.2</b>	<b>MOC-N (No. 1413-2000); 2 (1)(d)</b> Step depth $y_1 \geq 0,35 \text{ m}$ for angle of inclination more than $30^\circ$
<b>5.3.2.2.2</b> <i>No comment necessary</i>		
<b>5.3.2.2.3</b> General requirement step treads	<b>6.1.3.5.5/6.2.3.5.1</b> same requirements	No requirements for steps

Table 5 (continued)

<b>5.3.2.2.3</b>		
<i>Comment on demarcation lines: Plastic inserts (flat) are permitted by all codes. If they are used, they have to be of limited flammability along with the whole step assembly (see 5.9).</i>		
<b>5.3.2.2.4</b> Requirements step riser	<b>6.1.3.5.3</b> Nearly same intention	No requirement
<b>5.3.2.2.5</b> Width of grooves $b_7$ $5 \text{ mm} \leq b_7 \leq 7 \text{ mm}$	<b>6.1.3.5.5/6.2.3.5.1</b> $b_7 \leq 6,5 \text{ mm}$	No requirement
<b>5.3.2.2.5</b> No comment.		
<b>5.3.2.2.6</b> Depth of grooves $h_7 \geq 10 \text{ mm}$	<b>6.1.3.5.5/6.2.3.5.1</b> $h_7 \geq 9,5 \text{ mm}$	No requirement
<b>5.3.2.2.6</b> No comment.		
<b>5.3.2.2.7</b> Web width $2,5 \text{ mm} \leq b_8 \leq 5 \text{ mm}$	<b>6.1.3.5.5/6.2.3.5.1</b> $b_7 + b_8 \leq 9,5 \text{ mm}$ pitch of cleats <i>pitch is relevant</i>	No requirement
<b>5.3.2.2.7</b> No comment.		
<b>5.3.2.2.8</b> Edge-cleat	<b>6.1.3.5.5 and 6.2.3.5.1</b>	No requirement
<b>5.3.2.2.9</b> Front edge sharpness relieved	No requirement	No requirement
<b>5.3.2.2.9</b> No comment		
<b>5.3.3 Structural design</b>		
<b>5.3.3.1</b> Load (steps, pallets, belt) $6\ 000 \text{ N/m}^2$	<b>6.1.3.9.4</b> 135 kg on $150 \text{ mm} \times 250 \text{ mm}$ <b>6.1.3.10.4</b> Safety factor $S = 5$ (against ultimate tensile strength) <i>different</i> <b>6.2.3.10.4</b> 135 kg for each $0,42 \text{ m}^2$ <b>6.2.3.11.4</b> Safety factor 5	<b>BSLJ-EO Art 129-12 (3)</b> Load <i>different</i> $P = 2\ 600 \text{ A [N]}$ <b>MOC N (No. 1418-2000)</b> Safety factor at normal operation is 3 against breaking point. Safety factor when safety device actuated is 2 against breaking point <b>JEAS-1003B</b> , Escalator specifications. <b>JEAS-1004B</b> , Structural calculation for escalator.
<b>5.3.3.1</b> EN 115-1 requires an equally distributed step load for the design. A17.1/B44 requires a unique step load with a defined load area on different locations on the tread surface. In addition, a safety factor against the ultimate tensile strength of the step material is required. JIS has no specific requirements.		
<b>5.3.3.2</b> Static tests	See <b>6.1.3.9.4</b>	no requirement
<b>5.3.3.2.1</b> Steps, static tests 3 000 N on plate $0,2 \text{ m} \times 0,3 \text{ m}$ deflection $\leq 4 \text{ mm}$	Design requirements for steps	
<b>5.3.3.2.1</b>		
<b>FUNDAMENTAL DIFFERENCES:</b> A static step assembly test is required by EN 115-1, including the step riser. EN 115-1 and A17.1/B44 define maximum deflection limits. JIS does not require a static test on steps.		

5.3.3.2.2 Static test step riser	No requirement	No requirement
<b>5.3.3.2.2</b>		
<i>FUNDAMENTAL DIFFERENCE: Only EN 115-1 requires a static test on the step riser.</i>		
5.3.3.2.3 Pallets, static test 7 500 N on plate 0,30 m × 0,45 m Deflection ≤ 4 mm (If not possible, other requirements)	See 6.2.3.10.4 Design requirement for pallets	No requirement
<i>5.3.3.2.3 A171/B44 has no static load test requirement for steps and pallets. A specific static design load for steps/pallets is a requirement.</i>		
5.3.3.3 Dynamic test steps/pallets Load 500 N – 3 000 N Frequency 5 - 20 Hz Cycles > 5 × 10 <sup>6</sup> 0,20 × 0,30 m Deformation ≤ 4 mm 5.3.3.3.1.1 Load test 5.3.3.3.1.2 Dynamic torsional test for steps 5.3.3.3.2.2 Dynamic torsional test for pallets	6.1.3.5.7 / 6.2.3.5.4/ 8.3.11 nearly the same Load 450 N – 3 000 N Frequency 10 Hz ± 5 Cycles > 5 × 10 <sup>6</sup> Area 0,2 m × 0,3 m, 25 mm thick Deformation ≤ 4 mm	No requirement
<i>5.3.3.3 A171/B44 and EN 115-1 define a specific dynamic test for escalator steps/pallets.</i>		
<i>FUNDAMENTAL DIFFERENCE: Only EN 115-1 is defining a torsional test.</i>		
(5.3.4.1) Implied but not defined	6.2.3.5.3 Alignment of pallet tread surfaces	No requirement
<b>(5.3.4.1)</b>		
<i>AGREED UPON: All codes should have the alignment of pallets specified</i>		
5.3.4 Guiding of steps if step chain breaks	6.1.3.8 Nearly the same	No requirement
<b>5.3.4 (1,2)</b>		
<i>FUNDAMENTAL DIFFERENCES: A limitation of displacement of steps in the guiding system is required by EN 115-1 in the useable area.</i>		
<b>5.3.5 Clearance between steps or pallets</b>		
5.3.5 Clearance between steps or pallets ≤6 mm. Figure 2, and Figure 6 In transition curves of moving walks max. 8 mm	6.1.3.5.4 Clearance between steps The maximum clearance between step treads on the horizontal run shall be 6 mm (0,25 in.) 6.2.3.5.2 Intermeshing pallets Alternate cleats on adjacent pallets shall intermesh so that there is no continuous transverse gap between adjacent pallets.	MOC-N(No.1413-2000); 2 (3) (b) (c) (3) Moving walks of which speed varies in halfway of travel: ≤5 mm MOC-N (No.1417-2000) 1 (1), (2) ≤5 mm JIS A4302-2006; 5.4.2(h) ≤5 mm JIS A 4302-2006; 5.4.2 (k)
<i>5.3.5: EN 115-1 and JIS require in detail clearances between steps.</i>		
<i>A171/B44 requires no specific dimensions but the meshing of adjacent steps.</i>		

4.4 Belts

Table 6 — Belts

EN 115-1 (Europe)	A17.1/B44 (North America)	Japanese Codes
<b>5.3.2.3 Belts</b>	<b>6.2.3.6.2</b>	No requirements
<b>5.3.2.3.1</b> Grooves in direction of movement required	<i>same</i>	
<b>5.3.2.3.2</b> Width of grooves $b_7$ $4,5 \text{ mm} \leq b_7 \leq 7 \text{ mm}$	<b>6.2.3.6.2</b> $b_7 \leq 6,3 \text{ mm}$	No requirements
<b>5.3.2.3.2</b> <i>A17.1/B44 and EN 115-1 define the pitch and the width of the groove at the tread surface of the belt. Japan has no requirements.</i>		
<b>5.3.2.3.3</b> Depth of grooves $h_7 \geq 5 \text{ mm}$	<b>6.2.3.6.2</b> $h_7 \geq 4,8 \text{ mm}$	No requirements
<b>5.3.2.3.4</b> Web width $4,5 \text{ mm} \leq b_8 \leq 8 \text{ mm}$	<b>6.2.3.6.2</b> $b_7 + b_8 \leq 13 \text{ mm}$ <i>pitch is relevant</i>	No requirements
<b>5.3.2.3.5</b> Finished with edge cleats Requirement for splicing of the treadway belt	<b>6.2.3.6.1</b> Splices <b>6.2.3.6.2</b> Slots <i>same</i>	No requirements
<b>5.3.3.2.4</b> 750 N on plate 0,15 m × 0,25 m × 0,025 m deflection between the edge supporting rollers $\leq 0,01 z_3$ <b>Figure 7</b>	<b>6.2.3.9.1 Supports</b> , requirements (see 5.2.5)	No requirements
<b>5.3.4 (1,2)</b> Guiding	<b>6.1.3.8</b> <i>Nearly the same</i>	No requirement
<b>5.3.4 (1,2)</b> <b>FUNDAMENTAL DIFFERENCES:</b> <i>A limitation of displacement in the guiding system is required by EN 115-1 in the useable area.</i>		
<b>5.3.4 (3)</b> Additional treadway supports along the centreline every $\leq 2,00 \text{ m}$	<b>6.2.3.9.1 (c) (2)</b> $\leq 1 830 \text{ mm}$	No requirements

4.5 Drive unit

Table 7 — Drive unit and braking system

EN 115-1 (Europe)	A17.1/B44 (North America)	Japanese Codes
<b>5.4 1 Driving machine</b>		
<b>5.4.1.1</b> At least one machine per escalator	<b>6.1.5.2/6.2.5.2</b> <i>same</i>	No requirement
<b>5.4.1.1</b> <b>AGREED UPON:</b> <i>A driving machine shall not operate more than one escalator or moving walk.</i>		
<b>5.4.1.2 Speed</b>		
<b>5.4.1.2.1</b> Deviation of nominal speed $\pm 5 \%$ , at nominal frequency and nominal voltage	No requirement on speed deviation	<b>JIS A 4302-2006 5.4.1 (b)</b> Speed $\leq 110 \%$ no load condition



Table 7 (continued)

EN 115-1 (Europe)	A17.1/B44 (North America)	Japanese Codes
<b>5.4.1.2.1</b>		
<b>FUNDAMENTAL DIFFERENCE:</b> A17.1/B44 has a maximum rated speed limited with this value (0,50 m/s).		
<b>5.4.1.2.2</b> Speed of escalators $v \leq 0,75$ m/s up to 30° $v \leq 0,5$ m/s (30° up to 35°)	<b>6.1.4</b> $v \leq 0,5$ m/s	<b>BSLJ-EO Art. 129-12 1.(5) and MOC-N (No.1417-2000); EXP. 2.(1) &amp;(2) and MOC-N (No.1413-2000); EXP. 2.(1)</b> $v \leq 45$ m/min (0,75 m/s up to 30°) $v \leq 30$ m/min (0,5 m/s 30° up to 35°)
<b>5.4.1.2.2</b> The limitation of the speeds are different		
<b>FUNDAMENTAL DIFFERENCE:</b> A17.1/B44 limits the speed to 0,5 m/s up to 30°.		
<b>5.4.1.2.3(1)</b> $v \leq 0,75$ m/s (speed of moving walks)	<b>6.2.4</b> 0° - 8°: $v \leq 0,9$ m/s (180 ft/min) 8° - 12°: $v \leq 0,7$ m/s (140 ft/min)	<b>MOC-N /No.1417-2000); 2 (1) and 2(2)</b> For inclination $\leq 8^\circ$ : $v \leq 50$ m/min (0,833 m/s) For inclination $>8^\circ$ and $\leq 15^\circ$ : $v \leq 45$ m/min (0,75 m/s)
<b>5.4.1.2.3 (2)</b> Exception: $v \leq 0,9$ m/s, if pallet width $\leq 1,1$ m and horizontal pallet movement $\geq 1,6$ m before entering the comb		
<b>5.4.1.2.3</b>		
<b>Comment:</b> All codes define a correlation between speed, treadway width, and angle of inclination of moving walks.		
<b>5.4.1.2.3 (3)</b> 12.2.2.2 For accelerating moving walks no requirements defined	No requirement	<b>MOC-N (No. 1413-2000); 2 (3) (h)</b> Moving walks of which speed varies in halfway of travel $v \leq 50$ m/min (0,833 m/s) at entrance and exit.
<b>AGREED UPON</b> for both 5.4.1.2.2 and 5.4.1.2.3: The speed limits of accelerating moving walks are outside the scope of all codes		
<b>5.4.1.3.1</b> Possibilities of connection between operational brake and main drive Auxiliary brake required if friction drive elements	<b>6.1.5.1</b> Same, but without driving belts <b>6.2.5.1</b> <b>6.1.5.3.1 (e)</b> <b>6.2.5.3.1 (e)</b>	No requirement
<b>5.4.1.3.1</b>		
<b>FUNDAMENTAL DIFFERENCES:</b> EN 115-1 permits a friction drive between operational brake and the step/pallet or belt drive with an additional auxiliary brake. A17.1/B44 does not allow a friction drive between operational brake and the step/pallet or belt drive. A main drive shaft brake (A17.1/B44)/auxiliary brake (EN 115-1) is not required in EN 115-1 for multiplex chains and more than one independent chain drive. <b>AGREED UPON:</b> Where an auxiliary brake is needed, there shall be a positive connection between the auxiliary brake and the step/pallet band.		
<b>(5.4.1.3.1.1)</b>	<b>6.2.3.13</b> Load on chain drives	No requirement
<b>(5.4.1.3.1.2)</b>	<b>6.2.3.14</b> Load on v-belt drives	No requirement

Table 7 (continued)

EN 115-1 (Europe)	A17.1/B44 (North America)	Japanese Codes																				
5.4.1.3.2 Safety factor of driving elements	6.1.3.10 Design factor of safety 6.2.3.11 Design factors of safety	<b>MOC-N (No. 1418-2000), 2 (3), 2 (4)</b> Safety factor at normal operation: – 7 (at installation) against breaking point – 4 (during use) against breaking point. Safety factor when safety device is actuated: – 2,5 (at installation) against breaking point – 2,5 (during use) against breaking point																				
<p><b>5.4.1.3.2</b> <b>Fundamental differences:</b> - EN 115-1 uses a passenger load of 5 000 N/m<sup>2</sup> and a safety factor of 5 for driving elements; - in combination with the formula used for machinery rated load, A17.1/B44 requires a safety factor of 10 for power transmission members and of eight, respectively, 10 depending on the material used. <b>AGREED UPON:</b> When employing the same criteria for the basis of the load rating, the safety factors for the machine and transmission elements are practically the same from code to code.</p> <table border="1" style="width: 100%; border-collapse: collapse; text-align: center;"> <thead> <tr> <th colspan="4">Rated load in N/m of length</th> </tr> <tr> <th>Step width</th> <th>600 mm</th> <th>800 mm</th> <th>1 000 mm</th> </tr> </thead> <tbody> <tr> <td>EN 115</td> <td>3 000 N/m</td> <td>4 000 N/m</td> <td>5 000 N/m</td> </tr> <tr> <td>A17.1/B44 (structural)</td> <td>2 202 N/m</td> <td>2 753 N/m</td> <td>3 304 N/m</td> </tr> <tr> <td>A17.1/B44 (machinery)</td> <td>1 675 N/m</td> <td>2 095 N/m</td> <td>2 514 N/m</td> </tr> </tbody> </table>			Rated load in N/m of length				Step width	600 mm	800 mm	1 000 mm	EN 115	3 000 N/m	4 000 N/m	5 000 N/m	A17.1/B44 (structural)	2 202 N/m	2 753 N/m	3 304 N/m	A17.1/B44 (machinery)	1 675 N/m	2 095 N/m	2 514 N/m
Rated load in N/m of length																						
Step width	600 mm	800 mm	1 000 mm																			
EN 115	3 000 N/m	4 000 N/m	5 000 N/m																			
A17.1/B44 (structural)	2 202 N/m	2 753 N/m	3 304 N/m																			
A17.1/B44 (machinery)	1 675 N/m	2 095 N/m	2 514 N/m																			
5.4.1.4 Information about hand winding device	No requirement	No requirement																				
<p><b>5.4.1.4</b> <b>FUNDAMENTAL DIFFERENCES:</b> Only EN 115-1 gives requirements if a hand winding device is provided.</p>																						
5.4.1.5 Manner of stopping the machine and check the contactor's stop condition	6.1.6.10/6.2.6.9.3 same	No requirement																				
<b>5.4.1.5</b>	<b>AGREED UPON:</b> There should be a redundancy in the safety circuit of the escalator/moving walk drive. The integrity should be checked before the escalator/moving walk is permitted to restart.																					
<b>5.4.2 Braking system</b>																						
<b>5.4.2.1 Operational brake</b>																						
5.4.2.1.1.1 General requirements	6.1.5.3.1 Brake escalator 6.2.5.3.1 Brake moving walk	Braking system <b>BSLJ-EO Art 129-12, 4</b>																				

Table 7 (continued)

EN 115-1 (Europe)	A17.1/B44 (North America)	Japanese Codes																
<p><b>5.4.2.1.1.1</b>  <b>FUNDAMENTAL DIFFERENCES:</b>                      - EN 115-1 and JIS describe the braking system.                      - EN 115-1 has additional requirements where the stopping distance exceeds the maximum value by 20 %.                      - A17.1/B44 contains more detailed brake requirements.</p>																		
<p><b>5.4.2.1.1.2</b> Automatically operation (brake); loss of supply or loss of control voltage</p>	<p><b>6.1.5.3.1(b)/6.2.5.3.1(b)</b> for brake the same                      different for braking system</p>	<p><b>BSLJ-EO Art 129-12, 5</b>  <b>MOC-N (No. 1424-2000),1(2)(b)</b></p>																
<p><b>5.4.2.1.1.2</b> EN 115-1 and A17.1/B445 address the loss of power and the function of the safety devices.</p>																		
<p><b>5.4.2.1.1.3</b> Type of operational brake</p>	<p><b>6.1.5.3.1 / 6.2.5.3.1</b> electrically released and mechanically or magnetically applied                      Different, no alternative</p>	<p>No requirement</p>																
<p><b>5.4.2.1.1.3</b>  <b>Fundamental differences:</b>                      - EN 115-1 permits types of brake other than electromechanical. In case of non-electromechanical brakes, an auxiliary brake shall be provided.  <b>AGREED UPON:</b> The actuation of any safety device shall result in the stopping of the escalator/moving walk.</p>																		
<p><b>5.4.2.1.1.4</b> Brakes released by hand</p>	<p>No requirement</p>	<p>No requirement</p>																
<p><b>5.4.2.1.1.4</b>  <b>AGREED UPON:</b> Brakes which can be released by hand shall require a continuous manual pressure to keep them open.</p>																		
<p><b>5.4.2.1.2</b> Function of electro-mechanical brake</p>	<p><b>6.1.5.3.1 (a), 6.1.5.3.1 (b), 6.2.5.3.1 (a) and (b)</b></p>	<p><b>BSLJ-EO; Art. 129-12, 5, EXP. for 5.4.2.1.2</b>                      Not required for 5.4.2.1.1.1.(3)</p>																
<p><b>5.4.2.1.3.1</b> Brake load per step (escalators)                      Width up to 0,6 m 60 kg                      &gt;0,6 m up to 0,8 m 90 kg                      &gt;0,8 m up to 1,1 m 120 kg</p>	<p><b>6.1.3.9.3</b> With escalator stopped                      *Annex → Tabulation of brake load                      Brake rated load (kg) = 0,27(W + 203) B<sub>1</sub>                      With escalator running                      Brake rated load (kg) = 0,21 (W + 203) B<sub>1</sub>                      Different</p>	<p>Not mentioned</p>																
<p><b>5.4.2.1.3.1</b>  <b>FUNDAMENTAL DIFFERENCES:</b> EN 115-1 defines brake load per step, A17.1/B44 defines dynamic and static loads. Japan has no specific brake load requirement.</p>																		
<table border="1"> <thead> <tr> <th>Step width</th> <th>600 mm</th> <th>800 mm</th> <th>1 000 mm</th> </tr> </thead> <tbody> <tr> <td>EN 115-1</td> <td>295 × H</td> <td>443 × H</td> <td>591 × H</td> </tr> <tr> <td>A17.1/B44 Static Load</td> <td>376 × H</td> <td>469 × H</td> <td>563 × H</td> </tr> <tr> <td>A17.1/B44 Dynamic Load</td> <td>292 × H</td> <td>365 × H</td> <td>438 × H</td> </tr> </tbody> </table>			Step width	600 mm	800 mm	1 000 mm	EN 115-1	295 × H	443 × H	591 × H	A17.1/B44 Static Load	376 × H	469 × H	563 × H	A17.1/B44 Dynamic Load	292 × H	365 × H	438 × H
Step width	600 mm	800 mm	1 000 mm															
EN 115-1	295 × H	443 × H	591 × H															
A17.1/B44 Static Load	376 × H	469 × H	563 × H															
A17.1/B44 Dynamic Load	292 × H	365 × H	438 × H															

Table 7 (continued)

EN 115-1 (Europe)	A17.1/B44 (North America)	Japanese Codes
<p><b>5.4.2.1.3.2</b> Stopping distances (escalators) (unloaded and downward moving loaded escalators)</p> <p><math>v = 0,5 \text{ m/s} \geq \text{min } 0,2 \text{ m}</math> and max 1,0 m</p> <p><math>v = 0,65 \text{ m/s} \geq \text{min } 0,3 \text{ m}</math> and max 1,3 m</p> <p><math>v = 0,75 \text{ m/s} \geq \text{min } 0,35 \text{ m}</math> and max 1,5 m</p> <p>Deceleration shall not exceed <math>1 \text{ m/s}^2</math></p>	<p><b>6.1.5.3.1 (c)</b></p> <p>Peak deceleration <math>0,91 \text{ m/s}^2</math></p> <p>Stopping in down direction</p> <p><i>Different</i></p>	<p><b>JIS A4302 5.4.1(c)</b></p> <p>0,1 m – 0,6 m</p> <p><math>\leq 0,5 \text{ m/s}</math></p> <p><b>BSLJ-EO; Art. 129-12 5</b></p> <p>Deceleration rate <math>\leq 1,25 \text{ m/s}^2</math></p> <p><b>MOC-N (No. 1424-2000); 1 (3)</b></p>
<p><b>5.4.2.1.3.2</b></p> <p><b>Fundamental differences:</b></p> <p>- A17.1/B44 and EN 115-1 require a limit of the deceleration rate for the braking action regardless of the braking distance</p> <p>- EN 115-1 specifies a minimum and a maximum stopping distance related to the speed.</p> <p><b>FUNDAMENTAL DIFFERENCES:</b> Japan requires a stopping distance for the unloaded escalator in upwards direction.</p>		
<p><b>5.4.2.1.3.3</b> Brake load (moving walks)</p> <p>Width up to 0,60 m 50 kg</p> <p>&gt;0,6 m up to 0,80 m 75 kg</p> <p>&gt;0,8 m up to 1,10 m 100 kg</p> <p>Greater width: 25 kg per 0,4 m length for each additional 0,3 m width</p>	<p><b>6.2.3.10.3 (a)</b> With moving walk stopped</p> <p>Brake rated load (kg) = <math>0,49 (W) C_1</math></p> <p>With moving walk running</p> <p>Brake rated load (kg) = <math>0,37 (W) C_1</math></p> <p><i>Different</i></p>	<p>No requirement</p>
<p><b>5.4.2.1.3.4 (1,2,3,5)</b> Stopping distances (moving walks) (unloaded and horizontally or downward moving loaded moving walks)</p> <p><math>v = 0,5 \text{ m/s} \geq \text{min } 0,20 \text{ m}</math> and max 1,0 m</p> <p><math>v = 0,65 \text{ m/s} \geq \text{min } 0,30 \text{ m}</math> and max 1,3 m</p> <p><math>v = 0,75 \text{ m/s} \geq \text{min } 0,35 \text{ m}</math> and max 1,5 m</p> <p><math>v = 0,9 \text{ m/s} \geq \text{min } 0,40 \text{ m}</math> and max 1,7m</p>	<p><b>6.2.5.3.1 (c)</b></p> <p>Peak deceleration <math>0,91 \text{ m/s}^2</math></p> <p>Stopping in horizontal or down direction</p> <p><i>Different</i></p>	<p>0,1 m – 0,6 m</p> <p><math>\leq 0,5 \text{ m/s}</math></p> <p><b>BSLJ-EO; Art. 129-12 5</b></p> <p>Deceleration rate <math>\leq 1,25 \text{ m/s}^2</math></p> <p><b>MOC-N (No. 1424-2000); 1 (3)</b></p> <p><b><math>S = V^2/9\ 000</math></b></p> <p><b>JIS A4302 5.4.1 c) 4)</b></p>
<p><b>5.4.2.1.3.4 and 5.2.1.3.5</b></p> <p>- Japan addresses no requirement for the braking distance or deceleration of moving walks.</p> <p>- EN 115-1 requires a brake load and a stopping distance related to the speed of the moving walk.</p>		

<b>5.4.2.2 Auxiliary brake</b>		
<b>5.4.2.2.1</b> Auxiliary brake >6 m required and two other items	<b>6.1.5.3.2</b> Required if driving machine brake is separated from main drive shaft by a chain <i>different</i> <b>6.2.5.3.2</b> Like above	<b>MOC-N (No. 1424-2000) EXP. 2 (notice of designing)</b> Not directly required if driving machine brake is separated from main drive shaft by a chain <i>Different</i>
<b>5.4.2.2.1</b> <b>FUNDAMENTAL DIFFERENCE:</b> - EN 115-1 does not require an additional brake to the machine brake for a rise up to 6 m and the use of multiplex chains or gears.		
<b>5.4.2.2.2 (1)</b> Deceleration (auxiliary brake) Deceleration of 1 m/s <sup>2</sup> shall not be exceeded.	<b>6.1.5.3.2</b> Brake capable of stopping a down-running escalator with brake rated load <b>6.2.5.3.2</b>	No requirement
<b>5.4.2.2.2 (1)</b> (see 5.4.2.1.3.2): EN 115-1 requires effective retardation. <b>FUNDAMENTAL DIFFERENCE:</b> - Japan has no requirement. - A.17.1 has not specified a deceleration rate. <b>AGREED UPON:</b> Safe stopping shall be defined precisely: The deceleration rate needs clarification.		
<b>5.4.2.2.2(2))</b> Stopping distances of auxiliary brake (5.4.2.1.3.1)	<b>6.1.5.3.2/6.2.5.3.2</b> No requirement	No requirement
<b>5.4.2.2.2(2)</b> <b>FUNDAMENTAL DIFFERENCE:</b> No requirement in Japan.		
<b>5.4.2.2.3</b> Mechanical (friction) type	<b>6.1.5.3.2/6.2.5.3.2</b> Mechanical or magnetically applied <i>Different</i>	No requirement
<b>5.4.2.2.3</b> <b>FUNDAMENTAL DIFFERENCES:</b> A17.1/B44 permits ceramic permanent magnet brake application.		
<b>5.4.2.2.4</b> Conditions for application of the auxiliary brake - ≥1,4 times of nominal speed - Reversal of travel	<b>6.1.5.3.2 / 6.2.5.3.2</b> Breakage of Main drive chain <i>Different</i>	No requirement
<b>5.4.2.2.4</b> <b>FUNDAMENTAL DIFFERENCES:</b> In accordance with EN 115-1, the auxiliary brake shall be effective before the speed exceeds a value of 1,4 times the nominal speed or unintentional reversal of the direction of travel .		
<b>5.4.2.2.5</b> Operation of auxiliary brake together with operational brake	<b>6.1.5.3.2/6.2.5.3.2</b> The main drive shaft brake is only applied when the main drive-chain breaks and is only required when a chain is used to connect the main drive shaft to the machine.	No requirement
<b>5.4.2.3 Protection against risk of over speed and unintentional reversal of the direction of travel</b>		
<b>5.4.2.3.1</b> Overspeed; stop before 1,2 times of nominal speed	<b>6.1.6.3.2(a)</b> Stop before 1,4 times of rated speed/speed governor <b>6.2.6.3.2(a)</b> Stop before 1,4 times of rated speed/speed governor	No requirement

Table 7 (continued)

<b>5.4.2.3.1</b> <b>FUNDAMENTAL DIFFERENCES:</b> <i>There is no requirement for overspeed protection in the Japanese code. EN 115-limits by 1,2 times and A17.1/B44 at 1,4 times.</i>		
<b>5.4.2.3.2</b> Reversal of travel Automatically stop	<b>6.1.6.3.8/6.2.6.3.7</b> Automatically stop <i>Same</i>	No requirement
<b>5.4.2.3.2</b> <b>FUNDAMENTAL DIFFERENCES:</b> <i>The Japanese code has no specific requirement due to reversal of travel of the step/pallet band.</i>		
<b>5.4.3 Steps and pallets drive</b>		
<b>5.4.3.1</b> Chain drive for steps and pallets	<b>6.1.3.11/6.2.3.12</b> no cast iron links	<b>MOC-N (No. 1418-2000), 2(4) EXP.2</b>
<b>5.4.3.1</b> <b>FUNDAMENTAL DIFFERENCE:</b> <i>A17.1/B44 excludes cast iron for step chains.</i>		
<b>5.4.3.2</b> Safety factor $S \geq 5$ , based upon specific material Static load	<b>6.1.3.10.3/6.2.3.11.3</b> safety factor $S \geq 10$ machinery rated load	<b>MOC-N (No. 1418-2000, 2(3),(4))</b> Safety factor at normal operation: – 7 (at installation) against breaking point – 4 (during use) against breaking point. Safety factor when safety device is actuated: – 2,5 (at installation) against breaking point – 2,5 (during use) against breaking point rated load + weight + pretension
<b>5.4.3.3</b> Tensioning of step chain	No specific requirement for automatic step chain tensioning Safety switch required	Step chain elongation device required MOC-N (No. 1424-2000), 1(2) (a) JIS A 4302-2006 5.4.2 (a)
<b>5.4.3.3</b> <b>Comment:</b> <i>A17.1/B44 requires a broken step chain device if no automatic step chain tensioning device is provided (see A17.1/B44, 6.1.6.3.3).</i>		

<b>5.4.4 Belt drive</b>		
<b>5.4.4.1</b> Drum drive for belt Safety factor incl. splicing $\geq 5$ for the worst case loading	<b>6.2.3.11.5</b> Safety factor $\geq 5$ Different load requirement <b>6.2.3.10.2</b>	<b>MOC-N (No. 1418-2000),2(3) and 2(4)</b> Safety factor at normal operation: - 7 (at installation) against breaking point - 4 (during use) against breaking point. Safety factor when safety device is actuated: - 4 (at installation) against breaking point - 2,5 (during use) against breaking point rated load + weight + pretension
<b>5.4.4.2</b> Tensioning of belt	no requirement	no requirement
<b>5.4.4.2</b> <i>EN 115-1 requires a tensioning device for belts; tensioned springs are prohibited.</i> <b>AGREED UPON:</b> Belts shall be tensioned continuously and automatically.		
<b>(5.4.4.3) Other methods of driving steps, pallets, or belts</b>		
Not mentioned	No requirements (not usual in ASME procedures) <b>6.2.3.14</b> V-belt drives not permitted	No requirement
<b>(5.4.4.3)</b> <b>AGREED UPON:</b> Step chain tensioning devices are not used in modular escalators and some moving walk types. A safety code should not restrict the design of a step chain driving system.		

## 4.6 Balustrade

**Table 8 — Balustrade**

EN 115-1 (Europe)	A17.1/B44 (North America)	Japanese Codes
<b>5.5 Balustrade</b>		
<b>5.5.1 General</b>		
<b>5.5.1</b> Balustrades on each side	see <b>6.1.3.3/6.2.3.3</b>	<b>BSLJ-E0 Art. 129-12 1.(3)</b> <i>Same</i>
<b>5.5.1</b> <b>AGREED UPON:</b> The balustrade provides the passenger's safety by providing stability, protects the passenger from moving parts of the escalator, and supports the handrail.		
<b>5.5.2 Dimension of balustrade</b>		
<b>5.5.2.1</b> Height above steps $0,9 \text{ m} \leq h_1 \leq 1,1 \text{ m}$ <b>Figure 2 and 3</b>	<b>6.1.3.4.5/6.2.3.2.2</b> $900 \text{ mm} \leq h_1 \leq 1\ 000 \text{ mm}$ for escalators only	No requirement

Table 8 (continued)

EN 115-1 (Europe)	A17.1/B44 (North America)	Japanese Codes
<p><b>5.5.2.1</b> Japan does not specify limits for handrail height above steps/pallets.</p> <p><b>FUNDAMENTAL DIFFERENCE:</b> A17.1/B44 defines the handrail height from the step nose to the top of the handrail along the entire travel path.</p> <p>EN 115-1 defines it in the horizontal travel path and the landing area differently from floor plate level.</p> <p>The balustrade including the handrail is not considered to be a barrier as requested by building codes.</p>		
<p><b>5.5.2.2</b> Prevention of climbing on balustrades</p> <p>Specific dimensions</p>	<p><b>6.1.3.3.13/6.2.3.3.8</b> Deck barricades</p> <p><b>6.1.3.3.12</b> Anti-slide device, <i>special requirements</i></p>	<p><b>JEAS A406, 3.1.6</b></p> <p>Prevention of climbing on balustrades</p>
<p><b>5.5.2.2</b> (See Figure 4): The general intention is to prevent climbing and sliding by appropriate devices. These devices should be precisely defined as for example done in A17.1/B44 in future editions of escalator safety codes.</p> <p><b>AGREED UPON:</b> Deck barricade is a barricade to discourage climbing on the lower exterior outer deck. An anti-slide-device is a device to discourage sliding on the high exterior decks.</p>		
<p><b>5.5.2.3</b> Vertical force of 730 N/m and lateral force 630 N/m applied simultaneously</p>	<p><b>6.1.3.3.2/6.2.3.3.2</b> Vertical load 730 N/m, lateral load 584 N/m; simultaneously</p> <p><i>Different</i></p>	<p><b>JEAS-525 EXP.3.2</b></p> <p>Same as EN115-1 5.5.2.3</p>
<p><b>5.5.2.3</b> A17.1/B44 requires considering forces over the whole length of the balustrade. These typical forces are created when people are leaning against balustrades (handrails) and act simultaneously in the vertical and horizontal directions.</p> <p><b>Australia takes into account only a single vertical force.</b></p>		
<p><b>5.5.2.4 (1-3)</b> Balustrade construction, mouldings, cover joints, etc.</p>	<p><b>6.1.3.3.1, 6.2.3.3.1a</b> similar</p>	<p><b>MOC-N (No. 1417-2000), EXP.(1)</b></p> <p><i>Similar; no specific dimensions</i></p>
<p><b>5.5.2.4 (1-3)</b></p> <p><b>FUNDAMENTAL DIFFERENCES:</b> EN 115-1 gives limits to permanent deformation and permissible gap <math>\leq 4</math> mm for a defined load. A17.1/B44 and JIS have no load and deformation requirement.</p>		
<p><b>5.5.2.4 (4)</b> Force applied on the balustrade interior panelling</p> <p>500 N over 25 cm<sup>2</sup> <math>\geq</math> Gap <math>\leq</math> 4 mm</p> <p>No deformation</p>	<p>No requirement</p>	<p>No requirement</p>
<p><b>5.5.2.4(4)</b> EN 115-1 limits the gaps between panels to 4 mm. A17.1/B44 limits the gap between panels to 5 mm.</p>		
<p><b>5.5.2.4 (5)</b></p>	<p><b>6.1.3.3.3/6.2.3.3.3</b></p>	<p><b>JEAS-525, 3.1, 6 mm</b></p>
<p><b>5.5.2.4 (5)</b> Terminology problems are raised when discussing the use of glass for balustrades. For example, safety glass means (and is used as) laminated glass in the A17.1/B44 with reference to national glass standards (the use of polycarbonate is also permitted). In case of glass panels, EN 115-1 requires toughened glass.</p> <p><b>FUNDAMENTAL DIFFERENCE:</b> No requirements on thickness and type of glass in A17.1/B44, but test criteria are given.</p>		
<p><b>[5.5.2.4 (6)]</b> Sharp edges deleted from previous version, no general requirements</p>	<p>No requirement</p>	<p>No requirement</p>
<p><b>(5.5.2.4 (6) Comment:</b> Not generally specified in standards. It is considered as being state of the art.</p>		
<p><b>5.5.2.5</b> Balustrades with centred handrails</p>	<p>No requirement</p>	<p>No requirement</p>
<p><b>5.5.2.6</b> Lower inner decking</p> <p><math>\gamma \geq 25^\circ</math> see Figure 3</p>	<p><math>20^\circ \leq \gamma \leq 30^\circ</math> interior low deck</p> <p><b>6.1.3.3.4 (b)/6.2.3.3.4 (b)</b></p>	<p>No requirement</p>



Table 8 (continued)

EN 115-1 (Europe)	A17.1/B44 (North America)	Japanese Codes
5.5.2.6.1 $b_4 < 30$ mm (see Figure 3)	$b_4 \leq 35$ mm 6.1.3.3.4 (c)/6.2.3.3.4 (c)	No requirement
5.5.2.6/5.5.2.6.1: Japan has no requirement on the angle ( $\gamma$ ) of the interior lower deck. A17.1/B44 requires between 20° and 30°, EN 115-1 requires 25° or more.		
5.5.2.6.2 $b_3 < 0,12$ m if $\gamma \leq 45^\circ$ See Figure 3	$b_3 \leq 150$ mm 6.1.3.3.4(a)/6.2.3.3.4 (a) 6.1.3.3.4(d) The deck and the dynamic skirt panel cover, where provided, at the point closest to the step, shall withstand a force of 900 N (200 lbf) perpendicular to the line of attachment of the element without detachment or permanent deformation. The force shall be applied to an area of 645 mm <sup>2</sup> (1 in 2).	No requirement for angle BSLJ-E0; Art. 129-12, 1 (4) Between edge of step and centre of handrail $\leq 0,25$ m
5.5.2.6.2 <b>FUNDAMENTAL DIFFERENCES:</b> A17.1/B44 requires a maximum of 0,15 m. EN 115-1 requires a maximum of 0,12 m.		
5.5.3 Skirting		
5.5.3.1, 5.5.3.2 Skirting $h_2 \geq 25$ mm	6.1.3.3.6 $h_2 \geq 25$ mm 6.2.3.3.6	No requirement
5.5.3.1, 5.5.3.2 <b>Comment:</b> To define the height of skirting A17.1/B44 is using the nose-line (path of the traces by the nose of the step as it moves around the escalator) as reference line. EN 115-1 is using the tread surface of steps, pallets and belt as a reference. The meaning of each code is exactly the same.		
Note to 5.5.3.1 Jointing of skirting	6.1.3.3.6 (c)/6.2.3.3.6 (d)	No requirement
5.5.3.3 Force applied to skirting 1 500 N over 25 cm <sup>2</sup> $\geq$ Deflection $\leq 4$ mm	6.1.3.3.6 (b)/6.2.3.3.6 (c) 667 N Deflection. $\leq 1,6$ mm nearly the same Depends on how the force applies	No requirement
5.5.3.3 See 5.5.2.4 (4) <b>Comment:</b> A17.1/B44 is equivalent to EN 115-1. A deflection of 4 mm would require 1 667 N.		
5.5.3.4 Skirting requirements	6.1.3.3.6/6.2.3.3.6 Skirt panels 6.1.3.3.7 Additional requirements for dynamic skirts . 6.1.3.3.8 Dynamic skirt loaded gap 6.1.3.3.9 Step/skirt performance index 6.1.3.3.10 Skirt deflector device	BSLJ-E0; Art. 129-12, 1 (1) MOC-N (No.1417-2000); 1 (1) EXP. 1 (1) Friction, gap smaller than 5 mm MOC-N (No.1424-2000) 1 (2) (d) JIS A4302 5.4.2 (h)
(5.5.3.5)	6.1.3.5.6 Step demarcation	JIS A 4302-2006, 5.4.2 (k) Requirements demarcation lines adjacent to the balustrade

**Table 8** (continued)

EN 115-1 (Europe)	A17.1/B44 (North America)	Japanese Codes
<p><b>5.5.3.4, (5.5.3.5)</b>  <b>Comment:</b> A17.1/B44 permits the use of deflector devices. EN 115-1 has a mandatory requirement for deflector devices. Japan does not require deflector devices but yellow or orange lines as demarcation on steps (JIS A4302/4.2.13).</p>		
<p><b>5.5.4 Newel</b></p>		
<p><b>5.5.4.1</b> Newel <math>l_2 \geq 0,6</math> m See Figure 2</p>	<p>No requirement</p>	<p>No requirement</p>
<p><b>5.5.4.2</b> Dimension <math>l_3 \geq 0,3</math> m (Definition of comb)</p>	<p>Extension beyond comb plates <math>l_3 \geq 300</math> mm <b>6.1.3.4.2/6.2.3.4.2</b></p>	<p><b>MOC-N (No. 1417-2000); EXP. 2 [Notice for design (2)]</b> Dimension <math>l_3 \geq 0,3</math> m related to a speed of more than 0,5 m/s</p>
<p><b>5.5.4.2</b>  <b>AGREED UPON:</b> The dimensions for the continuation of the handrail beyond the comb plate should be defined in all codes.  <b>Fundamental differences:</b>  A17.1/B44 defines only the extension beyond the line of points of the comb plate teeth.  - To the balustrade entry of the handrail (<math>l_4</math>).  The Japanese code gives requirements only for speed above 0,5 m/s.</p>		
<p><b>5.5.5 Clearance between steps, pallets or belt and skirting</b></p>		
<p><b>5.5.5.1</b> Clearance between steps and skirting <math>\leq 4</math> mm at either side, but max 7 mm for sum</p>	<p><b>6.1.3.3.5 Loaded gap between skirt and step</b>  New criteria added (step/skirt performance index) relating to step/skirt gap (with lateral load applied) and coefficient of friction of skirt panel.</p>	<p><b>MOC-N [1417-2000], 1 (1) and EXP. 1 (1)]</b> <math>\leq 5</math> mm <b>JIS A4302-2006; 5.4.2 (h)</b> <math>\leq 5</math> mm at each side</p>
<p><b>5.5.5.1</b>  <b>Fundamental differences:</b>  - A17.1/B44, JIS permit a larger maximum distance.</p>		
<p><b>5.5.5.2</b> Skirting above tread surface (moving walks)  Clearance between tread surface and underside of the skirting <math>\leq 4</math> mm</p>	<p><b>6.2.3.3.5</b> <math>\leq 6</math> mm</p>	<p><b>MOC-N [1417-2000], 1 (1), EXP. 1 (1)]</b> <math>\leq 5</math> mm <b>JIS A 4302-2006 5.4.2 (h)</b> <math>\leq 5</math> mm at each side</p>
<p><b>5.5.5.2</b>  <b>AGREED UPON:</b> The definition and requirement of clearance between pallets, belts, and skirting is necessary.</p>		

## 4.7 Handrail system

Table 9 — Handrail system

EN 115-1 (Europe)	A17.1/B44 (North America)	Japanese Codes
<b>5.6.1 General</b>		
<b>5.6.1 (1)</b> Handrail moving in the same direction; speed tolerance 0 % to +2 % of the speed of the steps	<b>6.1.3.4.1/6.2.3.4.1</b> same direction, Substantially same speed Curved escalator handrails, same angular velocity	<b>BSLJ-EO Art.129-12 1.(3)</b> Same direction, same speed <b>JIS A 4302-2006 5.4.2 (d)</b>
<b>5.6.1 (2)</b> Hand rail speed monitoring	<b>6.1.6.4/6.2.6.4</b> Handrail speed monitoring device	<b>BSLJ-EO Art.129-12 EXP1.(3)</b> <b>[Notice for design 1.(3)]</b> Handrail monitoring device
<b>5.6.1</b> <b>FUNDAMENTAL DIFFERENCES:</b> - EN 115-1 defines the handrail speed with a tolerance of -0 +2 %; - Japanese code does not require a speed monitoring device to stop the machine at under speed; - A17.1/B44 defines handrail speed requirements for curved escalators.		
<b>(5.6.1.1)</b> No requirement	<b>6.1.3.4.1/6.2.3.4.1</b> Retarding force of 450 N	<b>JIS A 4302-2006;</b> <b>5.4.2 Inspection to be carried out on upper and lower landings and on steps</b> Check of retarding force (150 N) for downward operation
<b>(5.6.1.1)</b> <b>FUNDAMENTAL DIFFERENCE:</b> A17.1/B44 defines a retarding force of 450 N oppositely to the direction of travel without speed change. Japan requires, for escalators, a retarding force applied to the handrail in down-running direction. The handrail should not stop (escalators). <b>AGREED UPON:</b> To define a load applied on the handrail which does not trigger the handrail speed monitoring device.		
<b>5.6.2 Profile and position</b>		
<b>5.6.2.1</b> Distance handrail to handrail profile guide $b_6 \leq 8$ mm	<b>6.1.3.4.6/6.2.3.4.5</b> $b_6 \leq 10$ mm	No requirement
<b>(5.6.2.1.1) no requirement</b>	<b>6.1.3.4.4/6.2.3.4.4 Splicing</b>	No requirement
<b>Comment:</b> As it is generally required to design a machine according to the state of the art (ISO 12100), pinching points, sharp edges, etc. must be avoided.		
<b>5.6.2.2</b> Width of handrail $70 \text{ mm} \leq b_2 \leq 100 \text{ mm}$ (see Figure 3)	No requirement	No requirement
<b>5.6.2.2</b> <b>Comment:</b> Only EN 115-1 has requirements.		
<b>5.6.2.3</b> Dimension $b_5 \leq 50$ mm	No requirement	No requirement
<b>5.6.2.3</b> Only EN 115-1 has requirements.		

<b>5.6.3 Distance between the handrail centrelines</b>		
<b>5.6.3</b> Distance between handrail centrelines; <b>Figure 3</b> $(b_1 - z_2) \leq 0,45$ m	<b>6.1.3.2.2/6.2.3.2.2</b> $(b_1 - z_1)/2 \leq 240$ mm	<b>BSLJ-EO Art. 129-12; 1 (4) and EXP. 1.(4)</b> $(b_1 - z_1)/2 \leq 25$ cm <b>MOC-N (No. 1413-2000), 2 (2) (c)</b> For wide pallet/belt greater than 1,1 m <b>MOC-N (No. 1413-2000), 2 (3) (f)</b> For variable speed moving walk
<i>5.6.3 The relationship between the centrelines of the handrail and step width is defined in all codes.</i>		
<b>5.6.4 Handrail entry</b>		
<b>5.6.4.1</b> Dimension $0,10$ m $\leq h_3 \leq 0,25$ m; <b>Figure 2 and 3</b>	No requirement	No requirement
<b>5.6.4.1</b> <i>To avoid entrapping, only EN 115 requires a clearance from the floor for the handrail entry.</i>		
<b>5.6.4.2</b> $l_4 \geq 0,3$ m	No requirement	No requirement
<b>5.6.4.2</b> Additional requirement for extended balustrade and handrail		
<b>5.6.4.2</b> See 5.5.4.2 above		
<b>5.6.4.3</b> Handrail entry guard required <i>[Table 6 i) safety switch]</i>	<b>6.1.3.4.3/6.2.3.4.3 Guards same</b> <b>6.1.6.3.12/6.2.6.3.10 Handrail entry device</b>	<b>MOC-N (No.1424-2000); 2 (e)</b> <i>Handrail entry guard required</i> <b>JIS A 4302-2006 5.4.2 (f)</b> Switch
<b>5.6.4.3</b> <i>A handrail entry guard is required in all escalator/moving walk standards.</i>		
<b>5.6.5 Guiding</b>		
<b>5.6.5</b> Handrail guiding	No requirement	No requirement
<b>5.6.5</b> EN 115-1 requires a guided and tensioned handrail system. No specific requirements are in the other codes.		

## 4.8 Landings

Table 10 — Landings

EN 115-1 (Europe)	A17.1/B44 (North America)	Japanese Codes
<b>5.7.1 Surface properties</b>		
<b>5.7.1</b> Landing area, secure foothold min 0,85 m	<b>6.1.3.5.1 (c), 6.1.8.3/6.2.3.5.1 (c) /6.2.8.3</b>	-
<b>5.7.1</b> <b>Comment:</b> <i>The choice of materials used in A17.1/B44 is restricted and access plates shall be securely fastened. A17.1/B44 requires a plate surface with secure foothold. EN 115-1 is defining anti-slip properties.</i>		

<b>5.7.2 Configuration of steps, pallets and belts</b>		
<p><b>5.7.2.1</b> Horizontal step movement 0,8 m with max 4 mm difference in level after leaving/before entering the comb.</p> <p>If <math>v &gt; 0,5</math> m/s or rise <math>&gt; 6,0</math> m <math>\geq 1,2</math> m</p> <p>No requirements for pallets</p>	<p><b>6.1.3.6.5</b> Minimum two flat steps Maximum four flat steps Without difference in level</p> <p><b>6.2.3.5.3 Alignment of pallet tread surfaces.</b> Adjacent ends of pallets shall not vary in elevation more than 1,6 mm (0,06 in.).</p>	<p><math>\alpha \leq 30^\circ</math></p> <p>No requirement</p> <p><b>MOC-N (No. 1413-2000),2(1)(e)</b></p> <p>Two flat steps with max 4 mm difference in level for more than <math>30^\circ</math>.</p>
<p><b>5.7.2.1</b></p> <p><b>AGREED UPON:</b> Horizontal step movement ("flat step"): A distance 400 mm beyond the comb shall be flat at all times. Where the rated speed is in excess of 0,5 m/s or the rise is in excess of 6 m, this distance shall be 800 mm.</p> <p>- EN 115-1 allows a tolerance in vertical height between two consecutive steps.</p> <p>- EN 115-1 requires to enlarge horizontal sections for rises above 6 m and speeds above 0,5 m/s.</p> <p>- Japan has only requirements above 6 m.</p> <p>- A17.1/B44 defines elevation for adjacent ends of pallets.</p>		
<p><b>5.7.2.2</b> Radius of curvature</p> <p>Upper landing: If <math>v \leq 0,5</math> m/s <math>\geq r \geq 1,00</math> m</p> <p>if <math>v &gt; 0,5</math> m <math>\geq r \geq 1,5</math> m; lower landing: <math>r \geq 1,00</math> m</p>	No requirement	No requirement
<p><b>5.7.2.2</b></p> <p><b>FUNDAMENTAL DIFFERENCE:</b> EN 115-1 defines a track radius for both the upper and lower transition from incline to horizontal. The reason behind is the (ergonomic, comfort) horizontal acceleration of the passenger. Japan and A17.1/B44 have no specific requirement.</p>		
<p><b>5.7.2.3</b> Radius of curvature for belt moving walks <math>r \geq 0,4</math> m</p>		No requirement
<p><b>5.7.2.3</b> No comment.</p>		
<p><b>5.7.2.4</b> For moving walks <math>&gt;6^\circ</math></p> <p>Upper landing: <math>\geq 0,40</math> m at max. angle of <math>6^\circ</math> before entering or leaving the comb</p>	<p><b>6.2.3.1</b> <math>\alpha \leq 3^\circ</math> within 900 mm of the entrance and exits</p>	No requirement
<p><b>5.7.2.4</b></p> <p><b>FUNDAMENTAL DIFFERENCES:</b> A17.1/B44 does not permit the incline of the entrance or exit of moving walks to exceed an angle of <math>3^\circ</math> within 900 mm. EN 115-1 requires a transition in the upper landing.</p>		
<p><b>5.7.2.5 (1,2)</b> Guiding of steps in the area of combs</p>	<p><b>6.1.3.6.1 (c), (d)</b></p> <p><b>6.2.3.8.1 (c), (d)</b></p>	<p><b>JIS A 4302-2006 5.4.2 (g)</b></p> <p>No requirement for step sagging</p>
<p><b>5.7.2.5 (1,2)</b> see comments on 5.7.3.3</p>		
<b>5.7.3 Combs</b>		
<p><b>5.7.3.1, first sentence</b> General</p>	<p><b>6.1.3.6.1 (a) Same</b></p> <p><b>6.2.3.8.1 (a)</b></p>	<p><b>JIS A4302 5.4.2 (g)</b></p> <p>Same</p>
<p><b>5.7.3.1</b></p> <p>No comment necessary</p>		
<p><b>5.7.3.2.1</b> Mesh in of combs width of comb teeth <math>\geq 2,5</math> mm</p>	<p><b>6.1.3.6.1 (b) Same but no width of comb teeth</b></p> <p><b>6.2.3.8.1 (b)</b></p>	<p><b>JIS A4302 5.4.2 (g)</b></p> <p>Same but no width of comb teeth</p>

Table 10 (continued)

5.7.3.2.2 Radius of teeth end $\leq 2$ mm	No requirement	No requirement
5.7.3.2.3 Design angle of comb $\beta \leq 35^\circ$	No requirement	No requirement
5.7.3.2.1, 5.7.3.2.2, 5.7.3.2.3 <b>AGREED UPON:</b> All standards describe the meshing of combs with the tread surface of steps, pallets, and belts. EN 115-1 describes the width, the radius of the teeth, and the design angle of the combs.		
5.7.3.2.4 Adjustment and replacement of combs 5.7.3.1, second sentence	6.1.3.6.1 (c) Same 6.2.3.8.1 (c)	No requirement
5.7.3.2.4, 5.7.3.2.1 s sentence <b>AGREED UPON:</b> A comb/comb plate should be adjustable and the combs should be readily replaceable.		
5.7.3.2.5 Rigidity of comb teeth	No requirement	No requirement
5.7.3.2.5 <b>AGREED UPON:</b> The comb teeth should break before the step/pallet tread breaks.		
5.7.3.2.6 Objects in area of combs, stopping escalator	6.1.6.3.13(a), (b)/6.2.6.3.11(a), (b) Comb-step impact device	No requirement
5.7.3.2.6 <b>FUNDAMENTAL DIFFERENCE:</b> A17.1/B44 defines a force to operate the switch. The Japanese code and EN 115-1 have no requirement for a stopping device.		
(5.7.3.2.7)	Visual distinction between comb and step 6.1.3.6.2/6.2.3.8.2	No requirement
(5.7.3.2.7) <b>FUNDAMENTAL DIFFERENCE:</b> A17.1/B44 requires a visual distinction between combs and steps.		
5.7.3.3.1 Mesh depth of combs into the grooves $h_8 \geq 4$ mm Figure 2, detail X	6.1.3.6.1 (b) Comb teeth below upper surface of treads; no dimension 6.2.3.8.1 (b) Comb teeth below upper surface of treads; no dimension	No requirement
5.7.3.3.2 Clearance $h_6 \leq 4$ mm Figure 2, detail X	Load for comb section, comb plate and landing plate assemblies 6.1.3.6.1 (d)/6.2.3.8.1 (d)	No requirement
5.7.3.3 <b>FUNDAMENTAL DIFFERENCE:</b> A17.1/B44 has a performance requirement for the mesh depth of combs (steps and pallets only). EN 115-1 is using design requirements.		

## 4.9 Machinery spaces, driving stations, and return stations

Table 11 — Machinery spaces, driving, and return stations

EN 115-1 (Europe)	A17.1/B44 (North America)	Japanese Codes
<b>5.8.1 General</b>		
<b>5.8.1 (1), (2)</b> Only accommodation of escalator/moving walk equipment permitted, except equipment for fire fighting	Not mentioned	Not mentioned
<b>5.8.1(3)</b> Requirements for protection in driving and return stations (guarding)	<b>6.1.7.3.4/6.2.7.3.4</b> Equivalent (see also <b>OSHA</b> )	No requirement
<b>5.8.1 (3)</b> <i>AGREED UPON: Effective protection shall be provided for all moving parts accessible when the escalator/moving walk is running.</i>		
<b>5.8.2 Dimension and equipment</b>		
<b>5.8.2.1</b> Machinery spaces 0,3 m <sup>2</sup> , but smaller side min 0,5 m	No requirement	No requirement
<i>5.8.2.1 EN 115-1 defines the standing area and the headroom for the machinery space. EN 115-1 and A17.1/B44 are defining specific requirements for inside truss and separate outside escalator machinery spaces (separate machine rooms).</i>		
<b>5.8.2.2</b> Additional requirements for lifting devices	No requirement	No requirement
<b>5.8.2.3</b> Main drive within step band 0,12 m <sup>2</sup> , smaller side 0,3 m	No requirement	No requirement
<b>5.8.2.3</b> <i>FUNDAMENTAL DIFFERENCES:</i> <i>- EN 115-1 requires a horizontal standing area in the working zone.</i>		
<b>5.8.3.1</b> Requirements for electric supply of lighting and socket outlets Separate switch for breaking the main supply	<b>6.1.7.1.1/6.2.7.1.1</b> Lighting remote machine room <b>6.1.7.1.2/6.2.7.1.2</b> Truss interior <i>More special requirements</i>	No requirement
<b>5.8.3.2</b> Requirements lighting machine rooms		
<b>5.8.3.1, 5.8.3.2</b> <i>FUNDAMENTAL DIFFERENCES:</i> <i>- Japan does not define lighting for the remote machine room and power supply in the truss interior.</i> <i>AGREED UPON: Socket outlets shall be provided in truss extensions. Power points (socket outlet, duplex receptacle, general purpose socket outlet) need to be defined.</i>		
<b>5.8.3.3</b> Requirement on socket outlet		No requirement
<b>4.14-13.6</b> (Socket outlet): <i>Japan has no requirement.</i> <i>FUNDAMENTAL DIFFERENCES: A17.1/B44, Rules 6.1.7.1 and 6.2.7.1.22 (NEC 620-85), requires limited voltage, limited current, and ground fault interruption.</i>		
<b>5.8.4</b> Requirements stop switch in driving and return stations	<b>6.1.6.3.5/6.2.6.3.5</b> Nearly the same <b>2.26.2</b> Gives requirements for safety switches	No requirement

Table 11 (continued)

EN 115-1 (Europe)	A17.1/B44 (North America)	Japanese Codes
<b>5.8.4</b> EN 115- and, A17.1/B44 include the same intent and description of stop switches and operational use.		
<b>AGREED UPON:</b> This is a fundamental requirement for all codes.		

#### 4.10 Electric installation and appliances

NOTE Electrical items generally used throughout industry, e.g. contactors and wiring material, are not compared. Special escalator and moving walk requirements for such electrical items will be explained.

Table 12 — Electric installation and appliances

EN 115-1 (Europe)	A17.1/B44 (North America)	Japanese Codes
<b>Clause 5.11</b> Electric Reference CENELEC <i>Not compared</i>	<i>Not compared</i> <b>Reference NFPA 70; CSA B44.1/ ASME A17.5</b> <b>For Canada, see CSA 22.1.</b>	<i>Not compared</i> <b>Reference JEAC 8001-2005; JIS A 4302-2006</b>
<p><b>5.11.1.1</b> <b>AGREED UPON:</b> The electric installation of escalators and moving walks should be so designed and manufactured to ensure protection against hazards arising from the electrical equipment. [The index shall make the following references: EN 115-1 (CENELEC), A17.1/B44 (NFPA 70; ASME A17.5), Japan (JEAC 8001-1995/JIS A 4302-1992)].</p> <p><b>5.11.1.2</b> Scope and limits of applications of the electrical equipment are defined in EN 115-1. The escalator or moving walk shall be considered as a whole. A17.1/B44 (NEC) defines the scope based on how the electrical equipment is listed and labelled. A17.5 defines how the equipment is tested and labelled.</p> <p><b>5.11.1.3</b> A17.1/B44 deals with that item in NFPA 70, Rule 620-71. <b>AGREED UPON:</b> The insulation for conductors should prevent electrical shock.</p> <p><b>5.11.1.5</b> The intent of EN 115-1 and NFPA 70, Rule 620.3 is the same for control and safety circuits. Compared with the aforementioned, Japan has no requirements.</p>		



Table 12 (continued)

EN 115-1 (Europe)	A17.1/B44 (North America)	Japanese Codes
<b>5.11.1.6</b>		
<b>AGREED UPON</b> The intent of the earthing requirements is the same for all codes, including their references.		
<b>5.11.2 (Contactors):</b> The comparison of standard electrical equipment for escalators and elevators (lifts) is part of the ISO/TC 178 tasks.		
There are specific requirements for escalators/moving walks related to the categories of the main contactors in EN 115-1 (for inching purposes).		
<b>5.11.3 (Protection of motors)</b>		
<b>AGREED UPON:</b> Motors for escalators and moving walks should be equipped with an overload protection and short circuit protection.		
<b>5.11.3.1</b> The USA National Electrical Code, NFPA 70, Rule 620-61 (c) and (d) requires, in addition, motor feeder and motor branch circuit short circuit and ground fault protection. Rule 620-62 requires selective coordination of the over-current devices in the disconnecting means with any other supply side over-current devices.		
<b>5.11.3.2</b> EN 115-1, Japan and NFPA 70 require overload protection.		
<b>5.11.3.3/4</b> The reset cycle of an overload device and the restart of an escalator after such an event is only defined in EN 115-1.		
<b>5.11.3.5</b> The requirements for generator driving motors are addressed in EN 115-1.		
<b>5.11.5.2</b>		
<b>AGREED UPON:</b> The intent to define a minimum for the cross-sectional area of conductors is for all codes, including reference standards the same.		
<b>5.11.5.3</b> EN 115- and A17-NFPA 70 cover various requirements for the methods of installation and cable insulation. Japan addresses these requirements in their reference standards.		
<b>5.11.5.4 (Connectors):</b> EN 115-1 describes requirements for the design of plug-in type connectors in safety circuits. Japan has no specific connector design requirement.		
<b>5.11.6</b> No comment		
<b>5.11.7</b>		
<b>AGREED UPON:</b> Means to discharge electrostatic loading should be provided.		

#### 4.11 Protection against electrical faults — Controls

Table 13 — Protection against electrical faults — Controls

EN 115-1 (Europe)	A17.1/B44 (North America)	Japanese Codes
<b>5.12.1 Protection against electric faults</b>		
<b>5.12.1</b> Not compared!	Not compared <b>Reference NFPA 70; A17.5</b>	Not compared <b>Reference JEAC 8001-2005; JIS A 4302-2006</b>
<b>5.12.1</b> "Protection against electrical fault" is covered by definition of several electrical faults in A17.1/B44 and Japanese standards. EN 115-1 covers the subject matter in greater detail.		
<b>FUNDAMENTAL DIFFERENCE:</b> The different approaches concerning electrical safety devices are not comparable		
<b>Agreed upon:</b>		
- Capacitors shall not be installed in any escalator/moving walk installation where their operation or failure may cause an unsafe operation.		

<b>5.12.2 Controls</b>		
<b>5.12.2.1 Starting and making available for use the escalator or moving walk</b>		
<b>5.12.2.1.1 Starting switch</b> - One or more switches - Authorized persons only - Step/ treadway within sight <i>Special requirements</i>	<b>6.1.6.1/6.2.6.1.1</b> <b>6.1.6.2.1/6.2.6.2.1</b> - Key switch to be in run position before escalator restart - Key operated, spring return type - Specific labelling sequence - Steps/treadway within sight - Automatic starting prohibited	<b>BSLJ-E0129-12, EXP.4 (notice of designing)</b> - Key operated start
<p><b>5.12.2.2.1 (Starting):</b>  <b>FUNDAMENTAL DIFFERENCES:</b> A17.1/B44 prohibits automatic starting from standstill. The switch for starting must be spring returned type to the "run" position and must be a cylinder type with a five-pin disk combination. Japan requires a key operated switch with an alarm.  <b>Agreed upon:</b>                      - Starting should be done by an authorized person with a key switch. The step/treadway has to be within the sight of this person.                      A stop button shall be within reach from the starting key switch location.</p>		
<b>5.12.2.1.2 Automatic starting</b> Escalator/moving walk shall move with at least 0,2 times the nominal speed when the person reaches the comb and then accelerate less than 0,5 m/s <sup>2</sup>	<b>6.1.6.2.1 (b)/6.2.6.2.1 (b)</b> Automatic starting Steps/pallets shall move with rated speed when a person reaches the comb intersection line	<b>JEAS 410B 3.2</b> Automatic starting <i>Special requirements</i>
<b>5.12.2.1.3 By automatic starting</b> - > direction of travel clearly visible start in predetermined direction	<b>6.1.6.1.1/6.2.6.1.2 Automatic starting prohibited</b>	<b>JEAS 410B; 3.3, 3.4 (1), 3.4 (2) and 3.4 (3)</b> Prevention against entering from exit side
<p><b>5.12.2.1.2/3</b>  <b>Fundamental differences:</b>                      - Different parameters for the speed of the approaching person.</p>		
<b>5.12.2.2 Stopping</b>		
<b>5.12.2.2.1 Positive mechanical separation of contact</b>	<b>6.1.6.13/6.2.6.12</b> Completion or maintenance of a circuit not permitted to stop the machine	
<p><b>5.12.2.2.1</b>  <b>AGREED UPON:</b> The completion or maintenance of an electrical circuit should not be used to stop an escalator/moving walk.</p>		
<b>5.12.2.2.1 Manual stopping in view of the steps</b>	<b>6.1.6.3.1 Emergency stop buttons</b> located in view of the steps	No requirement
<p><b>5.12.2.2.1</b>  <b>AGREED UPON:</b> Except for emergency stopping, the manual stopping operation must be done without passengers travelling on the escalator/moving walk.</p>		

Table 13 (continued)

5.12.2.2.2 Stopping in automatic operating mode	Automatic operation not permitted by Rule 6.1.6.1.1, 6.1.6.2.1 (b)/6.2.6.2.1 (b)	<b>[JEAS 410B 3. 1(1)]</b> NOTE: JEAS attached in parenthesis are draft and mentioned as reference data. These are intended to be replaced later.
<b>5.12.2.2.2</b> <b>AGREED UPON:</b> For EN 115-1, A17.1/B44 and Japan the intent is like in 5.12.2.2.1, i.e. stopping after all passengers have left the escalator/moving walk.		
5.12.2.2.3.1 Emergency stop devices (not automatically operated) - At or near the landings - Distances between additional stop buttons: 30 m on escalators; 40 m on moving walks	<b>6.1.6.3.1/6.2.6.3.1</b> <i>More special detailed requirements (Type, location, marking, buzzer, etc.)</i>	<b>BSLJ-EO Article 129-12, 4</b> Emergency stop devices
<b>5.12.2.2.3.1</b> <b>FUNDAMENTAL DIFFERENCE:</b> A17.1/B44 requires an alarmed cover over the stop device to discourage its misuse. Japan requires a cover over the stop device to discourage its misuse. EN 115-1 does not require a cover, but one may be fitted. EN 115-1 requires additional stop buttons for moving walks transporting shopping trolleys. No requirement in JIS. Not applicable for A17.1/B44. <b>AGREED UPON:</b> A red emergency stop button/stop device should be visibly located at both landings of the escalator/moving walk.		
5.12.2.2.3.2 Stop switch for emergency situation shall be safety contact according to 5.12.1.2	<i>Not addressed in A17.1/B44, but some parts are in ANSI/NFPA 70</i>	No requirement
<b>5.12.2.2.3.2</b> <b>AGREED UPON:</b> The function of the emergency button should have the same purpose as a safety device.		
5.12.2.2.4 Stopping initiated by monitoring or electric safety devices	<b>6.1.6. Electrical protection devices</b> <b>6.1.6.10.1;6.1.6.13;</b> <b>6.2.6.9.1; 6.2.6.12</b>	
<b>Table 6 a)</b> Overload (by means of automatic circuit breakers). Escalator/moving walk shall be stopped automatically. Starting shall be prevented.	<b>6.1.7.4.1</b> All electrical equipment and wiring shall conform to NFPA 70 or CSA-C22.1, whichever is applicable (ref. NFPA 70, Rule 620.61).	Addressed in <b>JEAC 8001- 2005; 3705-5</b> Requirement for motor overload protection No definition for restart
<b>Table 6 a)</b> <b>FUNDAMENTAL DIFFERENCE:</b> EN 115-1 and A17.1/B44 (by means of reference to NFPA 70) prevent starting after overload.		
<b>Table 6 b)</b> Overload (on basis of temperature increase). Escalator/moving walk shall be stopped automatically. Starting shall be prevented.	<b>6.1.7.4.1</b> All electrical equipment and wiring shall conform to NFPA 70 or CSA-C22.1, whichever is applicable (ref. NFPA 70, Rule 620.61).	Addressed in <b>JEAC 8001- 2005; 3705-5</b> Requirement for motor overload protection. No definition for restart

<b>FUNDAMENTAL DIFFERENCE:</b> None		
<b>Table 6 c)</b> Excessive speed or unintentional reversal of the direction of travel (according to 5.4.2.3). Starting shall be prevented (see also 5.12.2.4.1). Escalator/moving walk shall be stopped automatically.	<b>6.1.6.3.2/6.2.6.3.2</b> Speed –monitoring device/manual reset 20 % above rated speed <b>6.1.6.3.8/6.2.6.3.7</b> Reversal stop device/manual reset	No requirement
<p><b>Table 6 c)</b> <b>Agreed upon:</b> 1) For escalators and inclined moving walks an over-speed governor should be required. 2) The unintentional reversal of the up direction of travel should be monitored. <i>NOTE: EN 115-1 permits SIL 2.</i></p>		
<b>Table 6 d)</b> Closing of the auxiliary brake (according to 5.4.2.2.4). Escalator/moving walk shall be stopped automatically.	<b>6.1.6.3.4/6.2.6.3.4</b> broken drive chain device/manual reset See <b>6.1.5.3.2/6.2.5.3.2</b>	No requirement
<b>Table 6 e)</b> Breakage or undue elongation of parts immediately driving the steps, pallets, or the belt, e.g. chains or racks. Escalator/moving walk shall be stopped automatically. Starting shall be prevented.	<b>6.1.6.3.3/6.2.6.3.3</b> Broken step/ treadway chain device/manual reset	<b>MOC-N (No.1424-2000) 1 (1) and 1 (2) (a)</b> No requirement
<p><b>Table 6 d) and e)</b> <b>AGREED UPON:</b> Escalators/ moving walks should be equipped with a broken step chain device <i>NOTE: EN 115-1 permits SIL 1</i></p>		
<b>5.12.2.2.4.1, Table 6 f)</b> (unintended) Reduction of the distance between the driving and return devices Escalator/moving walk shall be stopped automatically	<b>6.1.6.3.3/6.2.6.3.3</b> Broken step/ Treadway chain device/manual reset	No requirement
<p><b>FUNDAMENTAL DIFFERENCE:</b> EN115-1 covers extension and reduction of the distance between driving and return devices. <i>NOTE: EN 115-1 permits SIL 1.</i></p>		
<b>Table 6 g)</b> Foreign bodies being trapped at the point where the steps, pallets or the belt enter the comb (according to 5.7.3.2.6) Escalator/moving walk shall be stopped automatically.	<b>6.1.6.3.13/6.2.6.3.11</b> Comb step/ pallet impact device/manually reset	No requirement
<p><b>Table 6 g)</b> A17.1/B44 specifies the force that the combplate switch is activated. JIS has no requirement <b>AGREED UPON:</b> The rule needs further detailed explanations for clarification. Definitions of “foreign body” and “horizontal load” and “vertical loads” are necessary.</p>		

<p><b>Table 6 h)</b> Stopping of a succeeding escalator or moving walk where an intermediate exit does not exist (see A.2.6) or the exit of the escalator or moving walk by structural measures is blocked.</p> <p>Succeeding escalator or moving walk shall be stopped automatically</p>	<p><b>6.1.6.6/6.2.6.6</b> Tandem operation</p>	<p>No requirement</p>
<p><b>Table 6 h)</b></p> <p><b>AGREED UPON:</b> Escalators in series with no intermediate exit should have the same step width and speed and should be interlocked.</p> <p><i>NOTE: EN 115-1 permits SIL 1</i></p>		
<p><b>Table 6 i)</b> Foreign bodies being trapped in the handrail entry.</p> <p>Escalator/moving walk shall be stopped automatically</p>	<p><b>6.1.6.3.12/6.2.6.3.10</b> handrail entry device/manual reset</p> <p>- If an object becomes caught or approaches the area</p>	<p><b>MOC-N (No.1424-2000) 1 (1) (2) (e)</b></p>
<p><b>Table 6 i)</b></p> <p><b>AGREED UPON:</b> A handrail entry device should be provided at each handrail entry into the balustrade and should cause interruption of power if activated.</p>		
<p><b>Table 6 j)</b> stop automatically</p> <p>Sagging of step or pallet (see 5.7.2.5).</p> <p><i>No displacement defined</i></p> <p>(Not for belt moving walks)</p> <p>Starting shall be prevented.</p>	<p><b>6.1.6.3.11/6.2.6.3.9</b> Step/pallet level device/manual reset</p> <p>detect if downward displacement at the top and the bottom of the escalator/moving walk <math>\geq 3</math> mm</p>	<p>No requirement</p>
<p><b>Table 6 j)</b></p> <p><b>FUNDAMENTAL DIFFERENCE:</b> EN 115-1 monitors any part of the steps/pallets. A17.1/B44 detects the downward displacement of the step riser or trailing edge of a pallet. EN115-1 prevents starting after sagging of step or pallet.</p>		
<p><b>Table 6 k)</b> Missing step/pallet (see 5.3.6).</p> <p>Escalator/moving walk shall be stopped automatically.</p> <p>Starting shall be prevented</p>	<p><b>6.1.6.5/6.2.6.5</b> Missing step/pallet device/missing dynamic skirt manually reset</p>	<p>No requirement</p>
<p><b>FUNDAMENTAL DIFFERENCE:</b> Australia and Japan do not require a missing step device</p> <p>Note: EN115 allows SIL 2</p>		
<p><b>Table 6 l)</b> Non-lifting of the braking system after starting the escalator or moving walk (see 5.4.2.1.1).</p> <p>Escalator/moving walk shall be stopped automatically.</p> <p>Starting shall be prevented (see also 5.12.2.4.1)</p>	<p>No requirement</p>	<p>No requirement</p>

<p><b>Table 6 l)</b>  <b>FUNDAMENTAL DIFFERENCE:</b> Only EN 115–1 has such a requirement.</p>		
<p><b>Table 6 m)</b> Hand rail speed deviation of more than - 15 % to the actual speed for more than 15 s (see 5.6.1)                      Escalator/moving walk shall be stopped automatically.                      Starting shall be prevented.</p>	<p><b>6.1.6.4/6.2.6.4</b> Handrail speed monitoring device                      Speed deviation ≥15 % within 2 s to 6 s range                      Activation of alarm signal</p>	<p><b>BSLJ-EO; Article 129–12 1.(3) (notice of designing)</b>  <b>JIS A 4302–2006, 5.4.2 (d)</b></p>
<p><b>Table 6 m)</b>  <b>FUNDAMENTAL DIFFERENCE:</b> EN115 requires the escalator or moving walk to be stopped in the event of a hand rail speed deviation of more than -15 % to the actual speed for more than 15 s. US requires escalator to be stopped if the speed deviation is greater than 15 % from the actual speed for more than 2–6 s (the 2 s to 6 s range is adjustable). JIS has no requirement.  <b>Expert comment:</b> At least 6 s should be allowed to stop the escalator with slowed handrail speed.</p>		
<p><b>Table 6 n)</b> Opened inspection cover in the area of the truss and/or removed or opened floor plate (see 5.2.4).                      Control device for opened covers.                      Escalator/moving walk shall be stopped automatically</p>	<p>No requirement</p>	<p>No requirement</p>
<p><b>Table 6 n)</b>  <b>FUNDAMENTAL DIFFERENCE:</b> Only EN 115–1 has such a requirement.                      Note: EN115 allows SIL 1</p>		
<p><b>Table 6 o)</b> Exceeding the maximum permitted stopping distances by more than 20 % (see 5.4.2.1.1).                      Starting shall be prevented</p>	<p>No requirement</p>	<p>No requirement</p>
<p><b>Table 6 o)</b>  <b>FUNDAMENTAL DIFFERENCE:</b> A17.1/B44 has no requirement for monitoring the maximum permitted stopping distances by more than 20 %.</p>		
<p><b>Table 6 p)</b> Fault to earth of a circuit in which there is an electric safety device.                      Escalator/moving walk shall be stopped automatically.                      Starting shall be prevented (see also 5.12.1.1.4)</p>	<p>No requirement</p>	<p>No requirement</p>
<p><b>Table 6 q)</b> Actuation of electrical safety device before putting removable hand winding device on machine</p>	<p>No requirement</p>	<p>No requirement</p>
<p><b>Table 6 r)</b> no requirement</p>	<p><b>6.1.6.3.6</b> Skirt obstruction device  <b>6.1.6.3.16</b> Dynamic skirt panel obstruction device</p>	<p><b>MOC-N (No. 1424–2000); 1 (1) and 1 (2) (d)</b></p>
<p><b>Table 6 r)</b> Skirt obstruction device (A17.1/B44) and skirt switch (Japan) have the intent to detect entrapped objects and prevent them from carrying into combplate.</p>		

<b>Table 6 s)</b> No requirement	<b>6.1.6.3.7/6.2.6.3.6</b> Rolling shutter device	<b>MOC-N (No.1424-2000) 1(2)(c)</b> <b>JEAS-A407</b> NOTE: JEAS attached in parenthesis are draft and mentioned as reference data. These are intended to be replaced later.
<b>Table 6 s)</b> <i>The purpose of the rule is to shut down the escalator/moving walk if the egress is restricted (A17.1/B44/ Japan) to prevent the operation of the escalator/moving walk.</i>		
<b>Table 6 t)</b> no requirement	<b>6.1.6.3.9</b> Step up-thrust device	No requirement
<b>Table 6 t)</b> <i>Step up-thrust device (A17.1/B44) to detect the step displaced upward in the lower transition curve and stop the escalator to avoid a damage of steps and combplate.</i>		
<b>Table 6 u)</b> No requirement	<b>6.1.6.3.10/6.2.6.3.8</b> Disconnected motor device/manually reset	No requirement
<b>Table 6 u)</b> <i>The purpose is to detect a failure in the connection between the motor and the gear box when the motor is not directly connected to the gear box.</i>		
<b>Table 6 v)</b> no requirement	<b>6.1.6.3.14</b> Step lateral displacement device/manually reset (curved escalators)	No requirement
<b>Table 6 v)</b> <i>In A17.1/B44 this rule is applicable for curved escalators and detects failures in the lateral support system of the circular path of the step chain.</i>		
<b>5.12.2.2.4.2</b> Switching off operations by safety contacts or safety circuits	<i>Addressed in National Electrical Code ANSI/NFPA 70</i>	No requirement
<b>(5.12.2.2.4.3)</b> No requirement	<b>6.1.6.8/6.2.6.7</b> Smoke detectors	No requirement
<b>(5.12.2.2.4.3)</b> <i>Smoke detectors are not required by A17.1/B44 code but the conditions of their operation are controlled by the A17.1/B44 rule.</i>		
<b>5.12.2.3 Reversal of direction of travel</b>		
<b>5.12.2.3</b> Reversal of direction of travel only possible if escalator/moving walk stands still	<b>6.1.6.10/6.2.6.9</b> control on operating circuits	no requirement
<b>5.12.2.3</b> <b>AGREED UPON:</b> <i>Intended reversal of the direction of travel should only be initiated at standstill of the escalator/moving walk.</i>		
<b>5.12.2.4 Restarting</b>		
<b>5.12.2.4</b> Re-starting	<b>6.1.6.14 /6.2.6.13</b>	No requirement
<b>5.12.2.4.1</b> Re-starting by switch	Manual reset	No requirement
<i>Special conditions</i>	<i>Special requirements</i>	
<b>5.12.2.4.1</b> <i>The purpose in EN 115-1 and A17.1/B44 is to restrict the re-starting of an escalator to an authorized person for manual reset type safety devices</i> <b>AGREED UPON:</b> <i>An escalator/moving walk should not be able to be re-started by any single means after the activation of a manually resettable safety device.</i> <i>A17.1/B44 has a further requirement of not losing any manual reset information upon the loss and reactivation of power.</i>		

<p><b>5.12.2.4.2</b> Reactivation for automatic restart</p> <p>Special conditions:</p> <ul style="list-style-type: none"> <li>- Supervision 0,30 m beyond each comb; special test cylinder</li> <li>- Starting according to 5.12.2.1</li> <li>- Electrical safety device</li> </ul>	<p><i>Automatic starting or restarting is not permitted</i></p>	<p>No requirement</p> <p>Not permitted</p>
<p><b>5.12.2.4.2 FUNDAMENTAL DIFFERENCE:</b> <i>A17.1/B44 and JIS do not permit automatic starting.</i></p> <p><i>EN 115-1 permits, subsequent to a stop button stop, an escalator/ moving walk to re-start automatically when a detection device is provided over the travel path of the unit.</i></p>		
<p><b>5.12.2.5 Inspection control</b></p>		
<p><b>5.12.2.5</b> Inspection control</p> <p><b>5.12.2.5.1</b> Inspection controls are required</p>	<p><b>6.1.6.2.2/6.2.6.2.2</b></p> <p>Stop switch requirement in inspection controls</p> <p><b>6.1.6.3.15/6.2.6.3.12</b></p>	<p>No requirement</p>
<p><b>5.12.2.5.2</b> Location of inspection control</p>	<p><b>6.1.6.2.2 (a) (1)/6.2.6.2.2 (a) (1)</b></p>	<p>No requirement</p>
<p><b>5.12.2.5.3</b> Control device</p> <p>Protection against accidental operation</p>	<p><b>6.1.6.2.2 (g)/6.2.6.2.2 (g)</b></p>	<p>No requirement</p>
<p><b>5.12.2.5.4</b> Control device</p> <p>Other starting switches shall be inoperative</p>	<p><b>6.1.6.2.2 (f) /6.2.6.2.2 (f)</b></p>	<p>No requirement</p>
<p><b>5.12.2.5</b></p> <p><b>FUNDAMENTAL DIFFERENCE:</b> <i>The inspection control key switch operated is not permitted in EN 115-1.</i></p>		

**4.12 Information for use**

**Table 14 — Information for use**

EN 115-1 (Europe)*	A17.1/B44 (North America)	Japanese codes
<b>7 Information for use</b>		
<b>7.1 General</b>		
<p><b>7.1</b> Documentation shall include an instruction handbook relating to use, maintenance, inspection, periodic checks, and rescue operations</p>	<p><i>Not part of A17.</i></p> <p><b>A17.2.3</b> is Inspectors Manual for escalators/moving walks</p>	<p><b>BSLJ Article 6 and 7</b></p> <p>(p2.2-29)</p>



<p><b>7.1</b> <b>AGREED UPON:</b> Adequate documentation to be delivered</p>		
<p><b>7.2 Signals and warning devices</b></p>		
<p><b>7.2.1.1</b> General requirements for signs a) Material (durable) b) Position (conspicuous) c) Language (country) and/or pictographs</p>	<p><b>6.1.6.9.1/6.2.6.8.1</b> Same</p>	<p>No requirement</p>
<p><b>7.2.1.1</b> <b>AGREED UPON:</b> Signs are needed to inform the passengers of safe conduct. They should be legible and durable.</p>		
<p><b>7.2.1.2.1, Annex G</b> Notices/pictographs near the entrances Additional notices</p>	<p><b>6.1.6.9.1/6.2.6.8.1</b> Some other signs <b>6.1.6.9.2/6.2.6.8.2</b> Additional signs</p>	<p>No requirement</p>
<p><b>7.2.1.2</b> <b>AGREED UPON:</b> Signs should carry <i>NOTE: A17.1/B44 plans to harmonize with the previous EN push chair symbol. Push chair symbol is shown on caution plate Figure 6.1.6.9.1</i> <b>Comment:</b> EN 115–1 has a further requirement indicating that dogs should be carried. A17.1/B44 requires “Keep clear from skirting (the US term is: “Avoid sides”)” Japan enables the carrying of wheel chairs on escalators by a special construction. <i>NOTE: A17.1/B44 recommends permitting additional signs 3 m from newel to address unique conditions. The additional sign rule is not a recommendation. It restricts additional signs in the direct area of the escalator (see rule 6.1.6.9.2).</i></p>		
<p><b>7.2.1.2.2</b> Emergency stop device Colour, marking</p>	<p><b>6.1.6.3.1/6.2.5.3.1</b> Additional Requirements like Cover, audible warning signal</p>	<p><b>BSLJ-E0129–12, 4,</b> <b>Emergency stop button</b> <b>EXP. (notice of designing)</b> Abuse protection guard</p>
<p><b>7.2.1.2.2</b> <b>AGREED UPON:</b> Stop buttons should be coloured red. <b>FUNDAMENTAL DIFFERENCE:</b> EN 115–1 does not require a cover and require the word “STOP” either on the device itself or in the immediate vicinity of the stop device. A17.1/B44 and Japan require the word “STOP” or “EMERGENCY STOP” on the cover of the device. It is practice in Japan to place descriptions/instructions next to the cover.</p>		
<p><b>7.2.1.2.3</b> barriers with “No access/ No entry” during maintenance, repair, or inspection</p>		<p>No requirement</p>
<p><b>7.2.1.2.3</b> <b>AGREED UPON:</b> Access to the escalator/moving walk should be barred during maintenance and/or repair activities. Any floor openings are to be suitably guarded. Any guarding used should bear a sign “NO ACCESS” or equivalent [instead of A17.1/B44 covered by OSHA (Occupational Safety and Health Administration — Department of the USA government)].</p>		
<p><b>7.2.1.3</b> Instructions for hand winding devices</p>		<p>No requirement</p>

Table 14 (continued)

<p><b>7.2.1.3</b>  <b>AGREED UPON:</b> Where hand winding devices are provided, instructions for use should be provided and the direction of travel be clearly marked.</p>		
<p><b>7.2.1.4</b> Notices on the access doors to machinery spaces, driving and return stations</p>	<p><b>6.1.7.3/6.2.7.3</b> Requires side access doors to be locked and access plates at top and bottom landings to be securely fastened by mechanical means</p> <p><b>6.1.7.3.4/6.2.7.3.4</b>  Fixed guard requirement</p>	<p>No requirement</p>
<p><b>7.2.1.4</b>  <b>AGREED UPON:</b> Notices should be required on access doors to machinery spaces to the effect of "DANGER – ACCESS TO UNAUTHORIZED PERSONS PROHIBITED".</p>		
<p><b>7.2.2</b> Special notices for escalators and moving walks starting automatically</p>	<p><i>Automatic starting prohibited</i></p>	<p><b>JEAS-410B 3.4 (1), (2), (3),</b></p>
<p><b>7.2.2</b>  <b>AGREED UPON:</b> A suitable signal system should be provided to indicate whether the system is available for use (e.g. traffic signals).</p>		
<p><b>7.3.1</b> Before first use, after major modifications, regular intervals</p>	<p><b>A17.1/B44 Section 8.10.4</b></p>	<p><b>BSLJ Article 6 and 7</b></p>
<p><b>7.3.1</b>  <b>AGREED UPON:</b> Escalators and moving walks should be tested and inspected prior to first use and at regular intervals and after major modifications.  <b>FUNDAMENTAL DIFFERENCE:</b> EN 115–1 requires the inspection/ tests to be conducted by a competent person as defined in EN 13015.  <i>"Competent person" is not defined in A17.1/B44</i>  <i>Regular inspection in Japan has to be carried out by qualified engineers.</i></p>		
<p><b>7.3.2</b> First inspection and test  Constructional inspection, acceptance inspection and test</p> <ul style="list-style-type: none"> <li>- Overall visual inspection</li> <li>- Functional test</li> <li>- Tests of safety devices</li> <li>- Test of brake(s)</li> <li>- Measurement of insulation resistance</li> </ul>	<p><i>Acceptance inspections for escalators are addressed in Part 8.10 of A17.1/B44</i></p>	<p><b>JIS A 4302</b>  <b>JEAS-1003B</b>  <b>JEAS 1004-B</b>  <b>JEAS-A1021A</b></p>
<p><b>7.3.2</b> EN 115–1 states the minimum requirements relative to calculation data, layout drawings and wiring diagrams.  Under 7.3.2, EN 115–1 specifies the parameters relative to construction, inspection and acceptance tests.  BSLJ is the procedural base employed in Japan under which documentation in accordance with JEAS 1003B, JEAS 1004B and JEAS A1021A is provided.</p>		
<p><b>7.3.3</b> Inspection and test after major modifications</p>	<p>Alterations in <b>Section 8.7.6</b></p>	<p><b>BSLJ Article 6 and 7</b></p>
<p><b>7.3.3</b> EN 115–1 and A.17.1 define what is to be considered as a major modification.</p>		

Table 14 (continued)

<b>7.4.1 (ex b, f) 13 Accompanying documents</b> Former register is now addressed in EN 13015	<i>A17.1/B44 asks for maintenance records in 8.6.1.4</i>	<b>Notification no. 25 of the Building Disaster Prevention Division, Articles 8 and 9</b>
<b>7.4.1 (ex b, f)</b> <i>EN 115-1 and Japan require a register to be compiled for each installation</i>		
<b>7.4.1 e)</b> Putting into operation, maintenance, and repair	<i>Does not address this item</i>	<b>BSLJ Articles 8 and 12</b>
<b>7.4.1 e)</b> <i>EN 115-1 includes the European Machinery Directive requirements for the manufacturer to provide operating and fault finding instructions.</i> <i>A17.1/B44 does not address these instructions.</i>		
<b>7.4.1 f)</b> Period inspection and test: safety devices, brakes, driving elements, steps/pallets, dimensions in EN 115-1; combs, skirting, handrails, electric	<b>8.6.8, Maintenance and testing</b>	Inspector's manual
<b>7.4.1 f)</b> <i>EN 115-1 advises the items to be addressed during periodic inspection and tests as does A17.1/B44 and Japan.</i> <i>JIS specifies at least yearly inspections.</i>		
<b>7.5</b> Marking of escalators and moving walks	<b>8.6.1.5 Code Data Plate</b> <b>8.9</b> Data plate Rule NOTE: Numbering of escalator/moving walk is done as a state requirement	No requirement
<b>7.5</b> <b>FUNDAMENTAL DIFFERENCE:</b> <i>EN 115-1 requires marking of manufacturing data visible from the outside. Japan has no specific requirement.</i>		

#### 4.13 Building interfaces

Table 15 — Building interfaces

EN 115-1 (Europe) *	A17.1/B44 (North America)	Japanese Codes
<b>A.2 Free space for users</b>		
<b>A.2.1</b> Minimum headroom $h_4 \geq 2,30$ m see Figure 2 and A.2	<b>6.1.3.12/6.2.3.15</b> $h_4 \geq 2,13$ m	<b>MOC-N (No. 1417-2000), EXP.1 (notice of designing 3)</b> <b>JIS A 4302 5..2 (n)-2006</b> <b>JEAS-A406 3.1.3</b> $h_4 \geq 2,1$ m
<b>A.2.1</b> <b>AGREED UPON:</b> <i>The minimum headroom shall be measured vertically from the step nose-line, landing plates and landings.</i>		
<b>A.2.2</b> Distance outer edge of handrail and walls $b_{10} \geq 80$ mm Vertical distance below the lower edge of the handrail $< 25$ mm	<b>6.1.3.2.2/6.2.3.2.2</b> $b_{10} \geq 100$ mm Vertical distance below the lower edge of the handrail $< 25$ mm	No requirement
<b>A.2.3</b> Distance to adjacent escalators $b_{10} \geq 160$ mm		No requirement

Table 15 (continued)

EN 115-1 (Europe) *	A17.1/B44 (North America)	Japanese Codes
<p><b>A.2.2, A.2.3</b>  <b>AGREED UPON:</b> Every code has to provide for unrestricted access to the handrail to avoid pinching or trapping hands or fingers.</p>		
<p><b>A.2.4</b>                      Requirements for guards at ceiling intersection see <i>h</i><sub>5</sub> Figure 2  <b>6.1.3.3.11/6.2.3.3.7</b> See appendix I, figI-5 more requirements  <b>MOC-N (No.1417-2000) 1 (3), EXP.1 (3) and EXP. (notice of designing) 2</b>                      Nearly the same</p>		
<p><b>A.2.4</b>  <b>Fundamental differences:</b> A17.1/B44 and EN 115-1 are using a specific description of the solid guard.</p>		
<p><b>A.2.5</b> Unrestricted area requirements</p>	<p>Safety zone requirements  <b>6.1.3.6.4/6.2.3.8.4</b></p>	<p><b>MOC-N (No. 1417-2000), EXP.2 (notice of designing) 2</b>                      No requirement for A.2.6</p>
<p><b>A.2.5</b> For requirement son surrounds of the escalator A17.1/B44 and EN 115-1 requirements have the same intention.  <b>FUNDAMENTAL DIFFERENCES:</b> Whereas all codes recognize a minimum safety zone the requirements laid down are different. Additionally, EN 115-1 requires the same maximum capacity for succeeding escalators and moving walks.</p>		
<p><b>(A.2.5)</b></p>	<p><b>6.1.3.6.3/6.2.3.3.8</b> Adjacent floor surfaces; no abrupt change in elevation of more than 6 mm</p>	<p>No requirement</p>
<p><b>(A.2.5)</b>  <b>FUNDAMENTAL DIFFERENCE:</b> A17.1/B44 restricts the adjacent building floor levels in accordance to the landing plate levels.</p>		
<p><b>A.2.6</b> Succeeding escalators/moving walks; w/o intermediate exits same capacity</p>	<p>No equivalent requirement</p>	<p>No requirement</p>
<p><b>A.2.7</b> Protection at landing</p>	<p>Requirements are defined in accordance with the provisions of the applicable building code</p>	<p><b>JEAS-A406 3.1.4</b></p>
<p><b>A.2.8</b> Sufficient lighting  <b>A.2.9</b> Lighting min 50 Lux</p>	<p><b>6.1.7.2/6.2.7.2</b> min 50 lx</p>	<p>No requirement</p>
<p><b>A.2.8, A.2.9:</b> A17.1/B44, EN 115-1 and A17.1/B44 require lighting on escalator surrounds and landings. The Japanese code does not specify lighting levels.</p>		
<p><b>A.3 Machinery spaces outside the truss</b></p>		
<p><b>A.3.1</b> Safe access to be provided</p>	<p>A17.1/B44 does not address this issue</p>	<p>No requirement</p>
<p><b>A.3.2</b> Lockable and accessible to authorized persons only</p>	<p><b>See 8.1.3</b> "Authorized personnel"</p>	<p>No requirement</p>
<p><b>Comment:</b> Only EN 115-1 and A17.1/B44 require a access for "authorized personnel" only.</p>		
<p><b>A.3.3 Lighting machinery spaces</b>                      Requirements lighting machine rooms; 200 lx at floor level in working areas, 50 lx in access routes</p>	<p><b>6.1.7.1.1/6.2.7.1.1</b> Lighting remote machine room</p>	<p>No requirement</p>

Table 15 (continued)

EN 115-1 (Europe) *	A17.1/B44 (North America)	Japanese Codes
<b>A.3.3</b>		
<b>Fundamental differences:</b>		
<b>AGREED UPON:</b> Socket outlets shall be provided in truss extensions. Power points (socket outlet, duplex receptacle, general purpose outlet, socket) need to be defined.		
<b>A.3.4</b> Emergency lighting for safe evacuation	Emergency lighting not addressed. 6.1.7.2 provides requirement for the light intensity at floor plates and steps.	No requirement
<b>A.3.4</b> A17.1/B44 has lighting requirement under all conditions.		
<b>A.3.5</b> Requirements for dimensions of separate machinery spaces	<i>For information only</i> No special requirements for separate machinery spaces, same as for machinery room. <b>ANSI/NFPA 70</b> <b>620-5 (working clearances);</b> <b>620-4 (live parts enclosed)</b>	No requirement (No requirement for external machine room)
<b>A.3.5</b>		
<b>Comment:</b> Only EN 115-1 describes a separate machine room (machinery space). A17.1/B44 describes it in a reference document as shown above.		
EN 115-1 and A17.1/B44 defining specific requirements for inside truss and separate outside escalator machinery spaces (separate machine rooms).		
<b>A.3.6</b> Access routes height 1,80 m, width 0,50 m (red. 0,40 m)		No requirement
<b>A.3.6</b> (see also 5.2.4)		
<b>FUNDAMENTAL DIFFERENCES:</b> A maximum permissible handling force for opening the access plates is required by A17.1/B44.		
<b>A.3.7</b> Height of separate machinery spaces $\geq 2,0$ m	References ANSI/NFPA 70	No requirement (No requirement for external machine room)
<b>A.3.7</b>		
<b>FUNDAMENTAL DIFFERENCES:</b> EN 115-1 describes the headroom in separate machine rooms, in front of control panels and in driving/return stations explicitly.		

**Annex A**  
(informative)

**Figures of EN115-1**

When symbols are used to compare principal dimensions (e.g.  $L_1$ ,  $b_8$ ,  $h_6$ , etc.), always those of EN 115-1, Figures 2, 3, 5, and 8 are used independent of the designation in other standards.

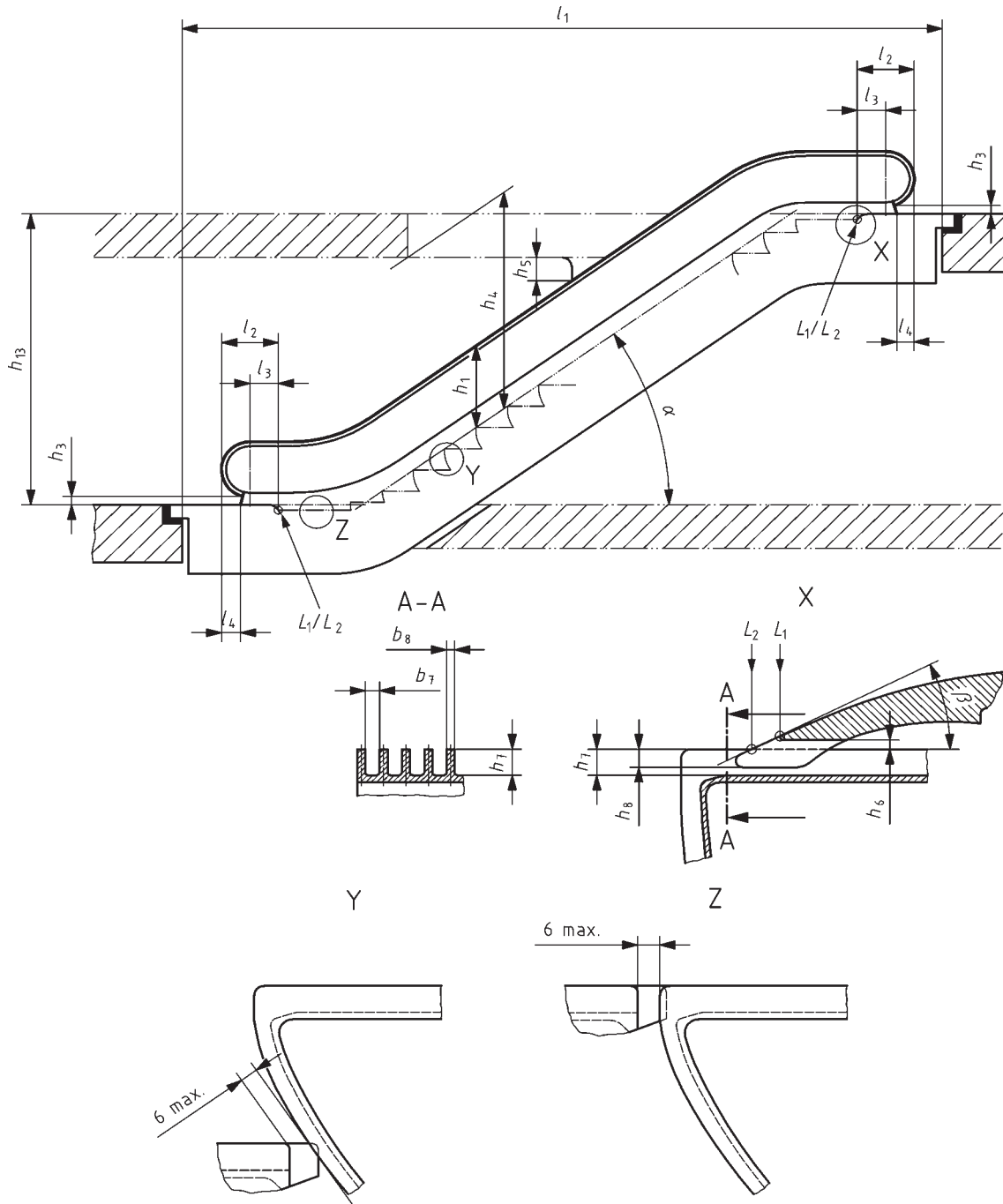

**Figure A.1 — Elevation view (EN 115-1, Figure 2)**

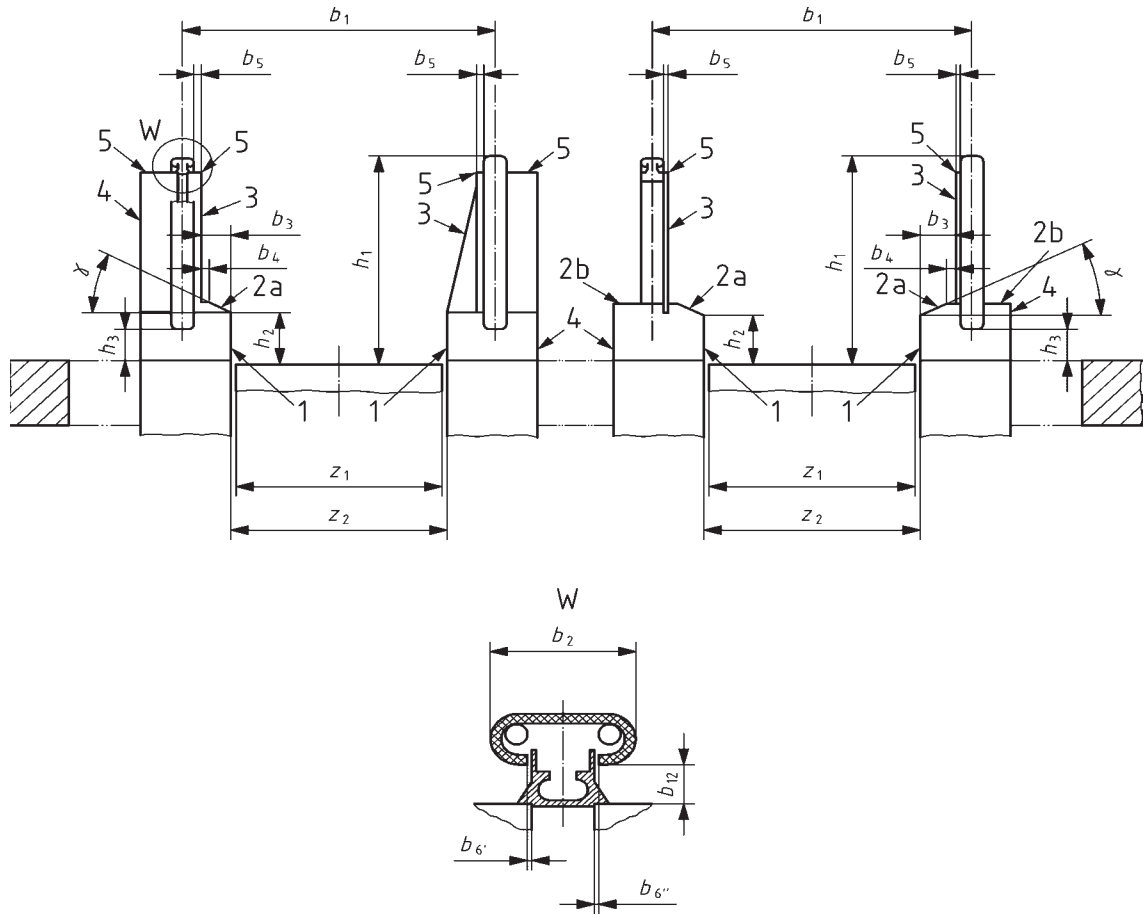

**Key**

- |    |                               |   |                              |
|----|-------------------------------|---|------------------------------|
| 1  | skirting (5.5.3)              | 3 | interior panel (5.5.2.4)     |
| 2a | lower inner decking (5.5.2.6) | 4 | exterior panel (5.2.1.2)     |
| 2b | lower outer decking (5.5.2.2) | 5 | balustrade decking (5.5.2.2) |

**Figure A.2 — Sectional view (EN 115-1, Figure 3)**

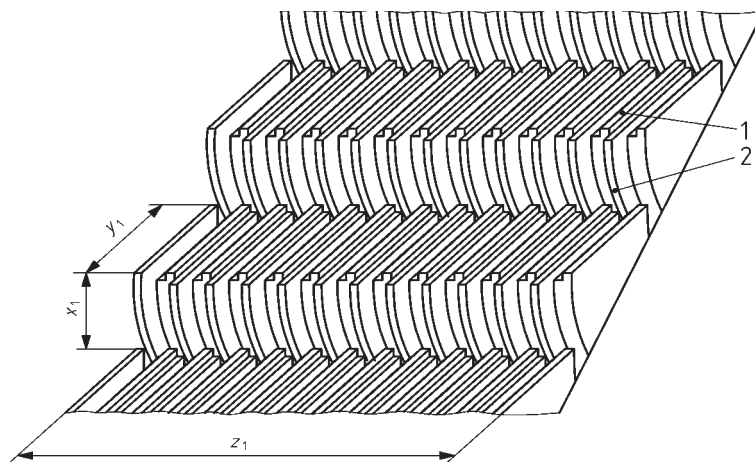

**Key**

- |   |             |
|---|-------------|
| 1 | step treads |
| 2 | step risers |

**Figure A.3 — Steps (principal dimensions) (EN 115-1, Figure 5)**

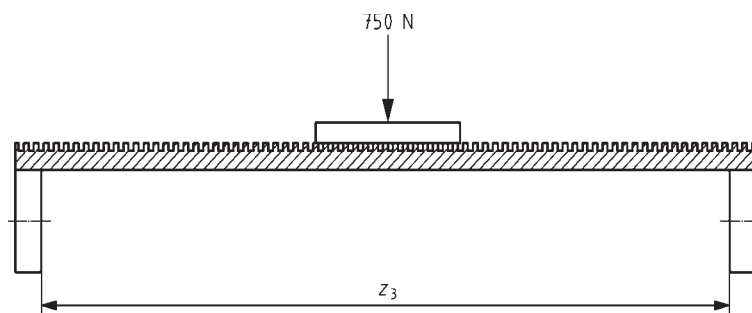

Figure A.4 — Belt (sectional view) (EN 115-1, Figure 8)



## Annex B (informative)

### References in the compared codes

#### B.1 References in EN 115-1:2008

EN 954-1:1996, *Safety of machinery — Safety-related parts of control systems — Part 1: General principles for design*

EN 1929-2, *Basket trolleys — Part 2: Requirements, tests and inspection for basket trolleys with or without a child carrying facility, intended to be used on passenger conveyors*

EN 1929-4, *Basket trolleys — Part 4: Requirements and tests for basket trolleys with additional goods carrying facility(ies), with or without a child carrying facility, intended to be used on passenger conveyors*

EN 1993-1-1, *Eurocode 3: Design of steel structures — Part 1-1: General rules and rules for buildings*

EN 10025-1, *Hot rolled products of structural steels — Part 1: General technical delivery conditions*

EN 10025-2, *Hot rolled products of structural steels — Part 2: Technical delivery conditions for non-alloy structural steels*

EN 10025-3, *Hot rolled products of structural steels — Part 3: Technical delivery conditions for normalized/normalized rolled weldable fine grain structural steels*

EN 10025-4, *Hot rolled products of structural steels — Part 4: Technical delivery conditions for thermomechanical rolled weldable fine grain structural steels*

EN 10025-5, *Hot rolled products of structural steels — Part 5: Technical delivery conditions for structural steels with improved atmospheric corrosion resistance*

EN 10025-6, *Hot rolled products of structural steels — Part 6: Technical delivery conditions for flat products of high yield strength structural steels in the quenched and tempered condition*

EN 10083-1, *Steels for quenching and tempering — Part 1: General technical delivery conditions*

EN 10083-2, *Steels for quenching and tempering — Part 2: Technical delivery conditions for non alloy steels*

EN 10083-3, *Steels for quenching and tempering — Part 3: Technical delivery conditions for alloy steels*

EN 12015, *Electromagnetic compatibility — Product family standard for lifts, escalators and moving walks — Emission*

EN 12016, *Electromagnetic compatibility — Product family standard for lifts, escalators and moving walks — Immunity*

EN 13015:2001, *Maintenance for lifts and escalators — Rules for maintenance instructions*

EN 13501-1:2007, *Fire classification of construction products and building elements — Part 1: Classification using data from reaction to fire tests*

EN 60068-2-6:1995, *Environmental testing — Part 2: Tests — Tests Fc: Vibration (sinusoidal) (IEC 60068-2-6:1995 + Corrigendum 1995)*

EN 60068-2-14, *Environmental testing — Part 2: Tests — Test N: Change of temperature (IEC 60068-2-14:1984 + A1:1986)*

EN 60068-2-27:1993, *Basic environmental testing procedures — Part 2: Tests - Test Ea and guidance: Shock* (IEC 60068-2-27:1987)

EN 60068-2-29, *Basic environmental testing procedures — Part 2: Tests; Test Eb and guidance: Bump* (IEC 60068-2-29:1987)

EN 60204-1:2006, *Safety of machinery — Electrical equipment of machines — Part 1: General requirements* (IEC 60204-1:2005, modified)

EN 60269-1, *Low-voltage fuses — Part 1: General requirements* (IEC 60269-1:2006)

EN 60439-1:1999, *Low-voltage switchgear and controlgear assemblies — Part 1: Type-tested and partially type-tested assemblies* (IEC 60439 1:1999)

EN 60529, *Degrees of protection provided by enclosures (IP code)* (IEC 60529:1989)

EN 60664-1:2007, *Insulation coordination for equipment within low-voltage systems — Part 1: Principles, requirements and tests* (IEC 60664-1:2007)

EN 60947-4-1, *Low-voltage switchgear and controlgear — Part 4-1: Contactors and motor-starters; Electromechanical contactors and motor-starters* (IEC 60947-4-1:2000)

EN 60947-5-1, *Low-voltage switchgear and controlgear — Part 5-1: Control circuit devices and switching elements - Electromechanical control circuit devices* (IEC 60947-5-1:2003)

EN 61249 series, *Materials for printed boards and other interconnecting structures* (IEC 61249 series)

EN 61558-1:2005, *Safety of power transformers, power supplies, reactors and similar products — Part 1: General requirements and tests* (IEC 61558-1:2005)

EN 62061, *Safety of machinery — Functional safety of safety-related electrical, electronic and programmable electronic control systems* (IEC 62061:2005)

EN 62326-1, *Printed boards — Part 1: Generic specification* (IEC 62326-1:2002)

ISO 12100-1:2003, *Safety of machinery — Basic concepts, general principles for design — Part 1: Basic terminology, methodology* (ISO 12100-1:2003)

ISO 12100-2:2003, *Safety of machinery — Basic concepts, general principles for design — Part 2: Technical principles* (ISO 12100-2:2003)

ISO 13849-2:2003, *Safety of machinery — Safety-related parts of control systems — Part 2: Validation* (ISO 13849-2:2003)

ISO 13850, *Safety of machinery — Emergency stop — Principles for design* (ISO 13850:2006)

ISO 13857:2006, *Safety of machinery — Safety distances to prevent hazard zones being reached by the upper and lower limbs* (ISO 13857:2008)

ISO 3864-1, *Graphical symbols — Safety colours and safety signs — Part 1: Design principles for safety signs in workplaces and public areas* (Note: Corrected and reprinted in 2003-12)

ISO 3864-3, *Graphical symbols — Safety colours and safety signs — Part 3: Design principles for graphical symbols for use in safety signs*

HD 21.3 S3, *Polyvinyl chloride insulated cables of rated voltages up to and including 450/750 V — Part 3: Non-sheathed cables for fixed wiring* (IEC 60227-3:1993, modified)

HD 21.4 S2, *Polyvinyl chloride insulated cables of rated voltages up to and including 450/750 V — Part 4: Sheathed cables for fixed wiring*

HD 21.5 S3, *Polyvinyl chloride insulated cables of rated voltages up to and including 450/750 V — Part 5: Flexible cables (cords)* (IEC 60227-5:1979, modified)

HD 22.4 S4, *Cables of rated voltages up to and including 450/750 V and having crosslinked insulation — Part 4: Cords and flexible cables*

HD 60364-4-41, *Low-voltage electrical installations — Part 4-41: Protection for safety — Protection against electric shock (IEC 60364- 4-41:2005, modified)*

IEC 60747-5-5, *Semiconductor devices — Discrete devices — Part 5-5: Optoelectronic devices — Photocouplers* (NOTE: This standard is intended to be published unmodified as an EN 60747-5-5.)

## **B.2 References in A17.1/B44**

CAN/CSA-B44.1/ASME A17.5-M 1991, *Standard for Elevator and Escalator Electrical Equipment*

ASME A17.2.3, *Inspectors' Manual for Escalators and Moving Walks*

ASME A17.3 (latest edition), *Safety Code for Existing Elevators and Escalators*

AISC Book #S326, 1978, *Specification for Design, Fabrication, and Erection of Structural Steel for Buildings*

ANSI/AWS D1.1 (latest edition), *Structural Welding Code — Steel*

ANSI/AWS D1.3 (latest edition), *Structural Welding Code — Sheet Steel*

ANSI/ASME B29.1, 1975, *Precision Power Transmission Roller Chains, Attachments, and Sprockets*

ASME QE1-1 (latest edition), *Standard for the Qualification of Elevator Inspectors*

ASME/ANSI Y1.1 (latest edition), *Abbreviations for Use on Drawings and in Text*

ANSI/NFPA 70-1993, *National Electrical Code®*

ANSI/NFPA 101 (latest edition), *Life Safety Code®*

ANSI/RMA IP-20, 1977, *Specifications for Drives Using Classical Multiple V-Belts (A, B, C, D, E Cross Sections)*

ANSI/UL94 (latest edition), *Test of Flammability of Plastic Materials for Parts in Devices and Appliances*

ANSI Z97.1-1984, *Performance Specifications and Methods of Test for Safety Glazing Material Used in Buildings*

## **B.3 References in the Japanese code**

JEA C8001, *Interior wiring code*

JEAS-1003B, *Escalator specifications*

JEAS-1004B, *Structural calculation for escalator*

JEAS-A 1021A, *Report of escalator conditions form after work completion*

JIS A 4302, *Inspection Standard of Elevator, Escalator and Dumbwaiter*

JIS C 2410, *P.V.C. tubing for electrical insulation*

JIS C 2415, *Extruded tubes for electrical insulation*

JIS C 3301, *Rubber insulated flexible cords*

JIS C 3306, *Polyvinyl chloride insulated flexible cords*

JIS C 3307, *V polyvinyl chloride insulated wires*

JIS C 3316, *Polyvinyl chloride insulated wires for electrical apparatus*

*JIS C 3317, 600V grade heat-resistant polyvinyl chloride insulated wires*

*JIS C 3327, 600V rubber insulated flexible cables*

*JIS C 3342, 600V polyvinyl chloride insulated and sheathed cables*

*JIS C 3401, Control cables*

*JIS C 3408, Travelling cables for elevators*

*JIS C 3652, Installation methods of power flat conductor cables*

*JIS C 8325, AC electromagnetic switches*

*JIS K 6324, Flame resistant conveyor belts — Classification and test method*

**Annex C**  
(informative)

**Addresses of standardization bodies occupied with the  
compared codes**

**EUROPE**

European Committee for Standardization

Avenue Marnix 17

**B-1000 Brussels**

**UNITED STATES OF AMERICA**

ASME International

Three Park Avenue

**New York, NY 10016-5990**

**CANADA**

Canadian Standards Association (CSA)

5060 Spectrum Way

Mississauga

ON L4W 5N6

**JAPAN**

Japanese Industrial Standards Committee

c/o Technical Regulation, Standards and Conformity Assessment Policy Unit,

Ministry of Economy, Trade and Industry

1-3-1, Kasumigaseki, Chiyoda-ku

**Tokyo 100-8901**

