**Comparison of worldwide escalator
and moving walk safety standards —**

**Part 1:
Rule by rule comparison**

*Comparaison des normes mondiales de sécurité des escaliers
mécaniques et trottoirs roulants —*

Partie 1: Comparaison paragraphe par paragraphe





COPYRIGHT PROTECTED DOCUMENT

© ISO 2015, Published in Switzerland

All rights reserved. Unless otherwise specified, no part of this publication may be reproduced or utilized otherwise in any form or by any means, electronic or mechanical, including photocopying, or posting on the internet or an intranet, without prior written permission. Permission can be requested from either ISO at the address below or ISO's member body in the country of the requester.

ISO copyright office
Ch. de Blandonnet 8 • CP 401
CH-1214 Vernier, Geneva, Switzerland
Tel. +41 22 749 01 11
Fax +41 22 749 09 47
copyright@iso.org
www.iso.org

Contents

	Page
Foreword	iv
Introduction	v
1 Scope	1
2 Rule by rule comparison	1
2.1 General	1
Annex A (informative) Figures of EN 115-1	154
Annex B (informative) Tables mentioned in the column for Japanese codes	160
Annex C (informative) References in the compared codes	162
Annex D (informative) Addresses of standardization bodies occupied with the compared codes	166

Foreword

ISO (the International Organization for Standardization) is a worldwide federation of national standards bodies (ISO member bodies). The work of preparing International Standards is normally carried out through ISO technical committees. Each member body interested in a subject for which a technical committee has been established has the right to be represented on that committee. International organizations, governmental and non-governmental, in liaison with ISO, also take part in the work. ISO collaborates closely with the International Electrotechnical Commission (IEC) on all matters of electrotechnical standardization.

The procedures used to develop this document and those intended for its further maintenance are described in the ISO/IEC Directives, Part 1. In particular the different approval criteria needed for the different types of ISO documents should be noted. This document was drafted in accordance with the editorial rules of the ISO/IEC Directives, Part 2 (see www.iso.org/directives).

Attention is drawn to the possibility that some of the elements of this document may be the subject of patent rights. ISO shall not be held responsible for identifying any or all such patent rights. Details of any patent rights identified during the development of the document will be in the Introduction and/or on the ISO list of patent declarations received (see www.iso.org/patents).

Any trade name used in this document is information given for the convenience of users and does not constitute an endorsement.

For an explanation on the meaning of ISO specific terms and expressions related to conformity assessment, as well as information about ISO's adherence to the WTO principles in the Technical Barriers to Trade (TBT) see the following URL: [Foreword - Supplementary information](#)

The committee responsible for this document is ISO/TC 178, *Lifts, escalators and moving walks*.

This second edition cancels and replaces the first edition (ISO/TR 14799-1:2005), which has been technically revised.

ISO/TR 14799 consists of the following parts, under the general title *Comparison of worldwide escalator and moving walk safety standards*:

- *Part 1: Rule by rule comparison*
- *Part 2: Abbreviated comparison and comments*

[Annexes A](#) to [C](#) form an integral part of this part of ISO/TR 14799.

Introduction

At the 1995 plenary meeting of ISO/TC 178, the work on a comparison of worldwide standards which includes the American, Australian, European, Russian, and Japanese escalator and moving walk safety code was passed to ISO/TC 178 (Resolution Singapore 1995/114). In October 1995, working group 5 was officially formed to carry out the task of preparing a cross reference between the relevant sections of these standards and to analyse the differences on selected subjects. The goal at that time was to prepare a Technical Report which would provide reference information to assist national committees when reviewing and revising individual standards which may initiate a gradual convergence of the technical requirements. In 1996, the study was expanded to include the Korean safety standard.

The content of this Technical Report is based on the information provided by the WG 5 members acting in personal capacity.

This Technical Report is intended to aid standards writers in developing their safety requirements and to help standards users understand the basis for the requirements as they are applied throughout the world.

This Technical Report is not intended to replace existing safety standards which may have been updated. Conclusions are arrived at in some cases, but only where there is unanimity amongst the various experts. In other cases, the reasons for the divergent views are expressed.

This Technical Report is to be read in conjunction with the various safety standards. Unless approved by the relevant standard writing organizations, the information contained in this Technical Report does not necessarily represent the opinions of these standards writing organizations (see Annex C for references).

This Technical Report was done with EN 115-1:2008 and its Amendment A1:2010 as a reference document shown as the only one in its normal sequence. All other codes are not in their normal sequence and logical order. They are structured differently to EN 115-1. The resultant incorrectly leaves the impression of incompleteness of these standards. These standards in their original structure inclusive of their references to other standards and requirements are however complete.

This comparison does no longer include the Australian, Korean, and Russian safety codes as there are intentions on national level to bring these codes in line with one of the remaining four codes.

Comparison of worldwide escalator and moving walk safety standards —

Part 1: Rule by rule comparison

1 Scope

This part of ISO/TR 14799 consists of a comparison of the requirements of selected topics as covered by the following worldwide safety standards (excluding local deviations):

- a) Europe (CEN) – EN 115-1, *Safety of escalators and moving walks — Part 1: Construction and installation* (Edition 2010, including Amendment 1);
- b) North America - ASME A17.1/CSA B44-2010, *Safety Code for Elevators and Escalators*;
- c) Japan – Safety requirements mainly comprised of Building Standard Law Enforcement Order (BSLJ-EO), Notifications of Ministry of Construction (MOC-N), Japan Industrial Standard (JIS), and Japan Elevator Association Standard (JEAS).

NOTE The original Japanese codes were written in Japanese and no official English versions had been released. Listed Japanese codes were carefully translated, but the original is corresponding to the translation sentence is not guaranteed.

It is to be noted that in addition to the above listed standards and other regulations, escalators and moving walks may be required to conform to the requirements of other standards, as appropriate. Where ISO/TC 178 was aware of these standards, they are mentioned in Annex C.

2 Rule by rule comparison

2.1 General

This comparison is between EN 115-1, the rules in A17.1/B44, and the Japanese codes. There are other standards in the countries concerned that have requirements not shown in the escalator/moving walk standards compared, but address some of the same requirements as EN 115-1 (see list in [Clause 1](#)).

The principal dimensions (e.g. L_1 , b_8 , h_6 , etc.) of EN 115-1 can be seen in the figures shown in [Annex A](#).

NOTE 1 EN 115-1 clause numbers in brackets serve only as a reference point. They do not exist in the published EN 115-1.

NOTE 2 Where the Australian Standard requirements are given in italics, they only apply to moving walks.

NOTE 3 Where a clause number in parentheses is used, this serves only as a reference point to EN 115-1.

EN 115-1 (Europe)	A17.1/B44 (North America)	Japanese codes
<p>Introduction</p> <p>This standard is a type C standard as stated in ISO 12100-1.</p> <p>The machinery concerned and the extent to which hazards, hazardous situations, and events are covered are indicated in the scope of this standard.</p> <p>When the provisions of this C standard are different from those which are stated in type A or B standards, the provisions of this type C standard take precedence over the provisions of the other standards for machines that have been designed and built according to the provisions of this type C standard.</p>	<p>No equivalent statement</p>	<p>—</p>
<p>The purpose of this standard is to define safety rules for escalators and moving walks in order to safeguard people and objects against risks of accidents during operation, maintenance, and inspection work</p>	<p>GENERAL</p> <p>This code is one of the numerous codes and standards developed and published by the American Society of Mechanical Engineers (ASME) under the general auspices of the American National Standards Institute, Inc. (ANSI).</p> <p>The code is intended to serve as the basis for state, municipal, and other jurisdictional authorities in drafting regulations governing the installation, testing, inspection, maintenance, alteration, and repair of elevators, dumbwaiters, escalators, moving walks, material lifts with automatic transfer devices, wheelchair lifts, and stairway chairlifts. It is also intended as a standard reference of safety requirements for the guidance of architects, engineers, insurance companies, manufacturers, and contractors, and as a standard of safety practices for owners and management of structures where equipment covered in the scope of the code is used.</p> <p>Safety codes and standards are intended to enhance public health and safety. Revisions result from committee consideration of factors such as technological advances, new data, and changing environmental and industry needs. Revisions do not imply that previous editions were inadequate.</p>	

EN 115-1 (Europe)	A17.1/B44 (North America)	Japanese codes
<p>The contents of this standard are based on the assumption that persons using escalators and moving walks are able to do so unaided. However, physical and sensory abilities in a population can vary over a wide range. Escalators and moving walks are also likely to be used by persons with a range of other disabilities.</p> <p>Some individuals, in particular, older people, might have more than one impairment. Some individuals are not able to use an escalator or moving walk independently and rely on assistance/support being provided by a companion. Furthermore, some individuals can be encumbered by objects or be responsible for other persons which can affect their mobility. The extent to which an individual is incapacitated by impairments and encumbrances often depends on the usability of products, facilities, and the environment.</p> <p>The use of wheelchairs on escalators and moving walks can lead to dangerous situations which cannot be mitigated by machine designs and therefore, should not be permitted.</p> <p>The use of lifts is the preferred method of vertical travel for most people with disabilities and in particular, wheelchair users and persons with guide dogs.</p> <p>Additional signs should be provided to indicate the location of other facilities. These facilities should be in close proximity to the escalators and moving walks and easy to find.</p>	No equivalent statement	—

EN 115-1 (Europe)	A17.1/B44 (North America)	Japanese codes
—	—	<p>BSLJ-EO (Fundamental Principles of Structural Design) Article 36-2</p> <p>In planning the structural design of buildings, columns, beams, floors, walls, etc., shall be arranged effectively according to use, scale, and structural features of the building concerned, as well as the conditions of the land concerned, so that the said building, as a whole, will be of structure safe from dead load, live load, snow load, wind pressure, ground pressure, and water pressure, as well as earthquakes or other vibration or shock acting upon the said building.</p> <p>2. Principal parts necessary for structural strength shall be arranged in balance so as to resist any horizontal forces acting upon the building concerned.</p> <p>3 Principal parts of a building necessary for structural strength shall be designed to have rigidity enough to prevent distortion or vibration adversely affecting the use of the said building and toughness enough to prevent sudden destruction.</p>
—	—	<p>BSLJ (Maintenance) Article 8-1</p> <p>The owner, custodian, or occupant of a building shall endeavour to maintain the site, structure, and building equipment of the building in a state complying with legal requirements.</p>

EN 115-1 (Europe)	A17.1/B44 (North America)	Japanese codes
		<p>BSLJ (Reports, Inspection, etc.) Article 12-2</p> <p>The owners of elevatory equipment and those of building equipment other than elevatory equipment (including building equipment installed in buildings of the State, a prefecture, or a city, town, or village having building officials) of a building as mentioned in article 6, paragraph 1, item (1), or any other building specified by cabinet order as mentioned in the preceding paragraph and designated by the special administrative agency, shall, in accordance with Ministry of Construction Order, have a 1st-class licensed architect/building engineer, 2nd-class licensed architect/building engineer, or a qualified person as designated by the Ministry of Construction periodically inspect the said building equipment, and report the inspection results to the special administrative agency.</p>
—	<p>PREFACE APPLICATION OF RULES TO NEW TECHNOLOGY</p> <p>Where present rules are not applicable or do not describe the product or system, the enforcing authority should recognize the need for exercising latitude and granting exceptions where the product or system is equivalent in quality, strength or stability, fire resistance, effectiveness, durability, and safety to that intended by the present code rules.</p>	—

EN 115-1 (Europe)	A17.1/B44 (North America)	Japanese codes
—	<p>1.1 Equipment covered by this code</p> <p>The provisions of this code are not intended to prevent the use of systems, methods, or devices of equivalent or superior quality, strength, fire resistance, effectiveness, durability, and safety to those prescribed by this code provided that there is technical documentation to demonstrate the equivalency of the system, method, or device.</p> <p>The specific requirements of this code may be modified by the authority having jurisdiction based upon technical documentation or physical performance verification to allow alternative arrangements that will ensure safety equivalent to that which would be provided by conformance to the corresponding requirements of this code.</p>	—
	<p>Definitions:</p> <p>enforcing authority - see authority having jurisdiction.</p> <p>approved - acceptable to the authority having jurisdiction.</p> <p>authority having jurisdiction - the organization, office, or individual responsible for approving equipment. Where compliance with this code has been mandated by law, the “authority having jurisdiction” is the federal, state, or local department or individual so designated in the enacting legislation or administrative regulation.</p>	
<p>It is assumed that negotiations have been made for each contract between the customer and the supplier/installer (see also Annex A) about the following:</p> <p>a) intended use of the escalator or moving walk;</p> <p>b) environmental conditions;</p> <p>c) civil engineering problems;</p> <p>d) other aspects related to the place of installation.</p> <p>If escalators or moving walks are intended to be operated under special conditions such as directly exposed to the weather or explosive</p>	<p>Outdoor escalators</p> <p>6.1.8.1/6.2.8.1 Weatherproofing. Escalators/moving walks shall be so constructed that exposure to the weather will not interfere with normal operation.</p> <p>6.1.8.1.1/6.2.8.1.1 The escalator/moving walk equipment and its supports shall be protected from corrosion.</p> <p>6.1.8.1.2/6.2.8.1.2 Electrical equipment shall be provided with a degree of protection of at least type 4 construction as specified in NEMA 250 and wiring shall be identified for use in wet locations in accordance</p>	<p>JEAS 520 Installation for outdoor condition</p> <p>2 Description</p> <p>2.1 Classification of the outdoor type and the semi-outdoor type escalator</p> <p>The escalator without overhead roof or whose line connecting the roof edge and the escalator forms an angle of less than 30° to the vertical line is classified as the outdoor type (refer to Figure 1) and the escalator with above angle of not less than 30° and not more than 70° is classified as the semi-outdoor type (refer to Figure 2).</p>

EN 115-1 (Europe)	A17.1/B44 (North America)	Japanese codes
<p>atmosphere, or in exceptional cases serve as emergency exits, appropriate design criteria, components, materials, and instructions for use should be used that satisfy the particular conditions.</p>	<p>with NFPA 70 or CSA C22.1, as applicable (see Part 9).</p> <p>6.1.8.2/6.2.8.2 Precipitation. A cover directly over the horizontal projection of the escalator/moving walk shall be provided. The cover shall extend outward from the centerline of the handrail so that a line extended from the edge of the cover to the centerline of the handrail forms an angle of not less than 15° from the vertical.</p> <p>6.1.8.2.1/6.2.8.2.1 When the escalator/moving walk is subjected to blowing snow or freezing rain, heating systems shall be operated to prevent accumulation of snow or ice on the steps/treradway, landings, and skirt deflector devices. The heating systems operation shall be thermostatically controlled and independent of the escalator/moving walk operation.</p> <p>6.1.8.2.2/6.2.8.2.2 Drains suitable for all weather conditions shall be provided to prevent the accumulation of water.</p> <p>6.1.8.3/6.2.8.3 Slip resistance. Landing plates and combplates shall be designed to provide a secure foothold when wet.</p>	<p>2.2 Considerations in construction</p> <p>As to the outdoor type and the semi-outdoor type escalators, the following considerations by the building side are required. It is also recommended that a roof be furnished especially in case of rainfall or snowfall where the treads are slippery and the passengers may lose their balances when getting on and off with the use of umbrellas.</p> <p>(1) The landings of the escalator should be installed higher than the surrounding floors so that rainwater or snow may not flow into the inside of the escalator and the drainage slope, as well as the drainage should be provided (refer to Figure 3).</p> <p>(2) An equipment for releasing water accumulated inside of the lower pit of the escalator should be furnished. Further, as drained water is mixed with oil, dust, or pebbles, a proper filtering device at the external drain is required and measures to prevent any adverse flow are recommended (refer to Figure 4)</p> <p>(3) In consideration of the use during night time etc., lighting fixtures are necessary to be equipped for the passengers to be able to see where they are stepping well.</p> <p>(4) At the pull-in end of the power source for the escalator, necessary protection measures are required.</p> <p>(5) The supervisory panel for supervision, TV camera, or the like are preferable to be furnished.</p> <p>(6) Depending on the installation circumstances, measures by heating devices or the like are recommended to be equipped to prevent freezing etc.</p>

EN 115-1 (Europe)	A17.1/B44 (North America)	Japanese codes
		<p>2.3 Considerations on supervision</p> <p>Concerning the outdoor type or the semi-outdoor type escalator, the following considerations on supervision in operation are recommendable.</p> <p>(1) In case of snowfall or freezing in winter, operation of the escalator should be suspended to prevent the passengers from sliding and the equipment from being damaged.</p> <p>(2) When operation of escalator is suspended, necessary measures should be taken not to be used as a stairway.</p> <p>(3) The lifetime of the equipment of the escalator which was installed under outdoor or semi-outdoor is generally shorter than that of indoor and therefore, regular maintenance and inspection in accordance with the installation circumstances are indispensable.</p> <p>2.4 Considerations on equipment</p> <p>Concerning the outdoor type or the semi-outdoor type escalator, the following considerations are required.</p> <p>(1) Adequate rustproof measures for the main structures are required.</p> <p>(2) Necessary protection measures for the electric apparatus are required.</p>
<p>An Interpretation Committee has been established to clarify, if necessary, the spirit in which the clauses of the standard have been drafted and to specify the requirements appropriate to particular cases. Interpretation requests can be sent to the National Standard Bodies which will contact the responsible Technical Committee (CEN/TC 10). The formats of an interpretation request and the interpretation are given in Annex L.</p>	<p>Requesting Interpretations.</p> <p>On request, the A17 committee will render an interpretation of any requirement of the code. Interpretations can only be rendered in response to a written request sent to the secretary of the main committee.</p> <p>The request for interpretation should be clear and unambiguous. It is further recommended that the inquirer submit his request utilizing the following format:</p>	<p>There is no Interpretation Committee.</p>

EN 115-1 (Europe)	A17.1/B44 (North America)	Japanese codes
	<p>Subject: Cite the applicable rule number(s) and a concise description.</p> <p>Edition: Cite the applicable edition and supplement of the code for which the interpretation is being requested.</p> <p>Question: Phrase the question as a request for an interpretation of a specific requirement suitable for general understanding and use, not as a request for an approval of a proprietary design or situation. The inquirer may also include any plans or drawings which are necessary to explain the question, however, they should not contain proprietary names or information.</p> <p>Requests which are not in this format will be rewritten in this format by the committee prior to being answered which may inadvertently change the intent of the original request.</p> <p>ASME procedures provide for reconsideration of any interpretation when or if additional information which might affect an interpretation is available. Further, persons aggrieved by an interpretation may appeal to the cognizant ASME committee or subcommittee. ASME does not “approve,” “certify,” “rate,” or “endorse” any item, construction, proprietary device, or activity.</p>	

EN 115-1 (Europe)	A17.1/B44 (North America)	Japanese codes
<p>1 Scope</p> <p>1.1 This standard is applicable for all new escalators and moving walks (pallet or belt type) as defined in Clause 3.</p>	<p>Scope equipment covered by this code</p> <p>This code of safety standards covers the design, construction, operation, inspection, testing, maintenance, alteration, and repair of the following equipment, its associated parts, and its hoistways, where located, in or adjacent to a building or structure (except as modified by paragraph 1.2):</p> <p>a) hoisting and lowering mechanisms equipped with a car or platform which move between two or more landings. This equipment includes, but is not limited, to the following (see Section 3, definitions):</p> <p>(1) elevators; (2) wheelchair and stairway chairlifts;</p> <p>b) power-driven stairways and walkways for carrying persons between landings. This equipment includes, but is not limited, to the following (see Section 3, definitions):</p> <p>(1) escalators; (2) moving walks;</p> <p>c) hoisting and lowering mechanisms equipped with a car which serves two or more landings and is restricted to the carrying of material by its limited size or limited access to the car. This equipment includes, but is not limited to, the following (see Section 3, definitions):</p> <p>(1) dumbwaiters; (2) material lifts and dumbwaiters with automatic transfer devices.</p>	<p>BSLJ (scope of application)</p> <p>Article 3</p> <p>The provisions of this section shall apply to the elevatory equipment installed in buildings and described in each of the following items.</p> <p>(2) Escalator</p> <p>Notwithstanding the provision of the preceding paragraph, the provisions of each said item shall not apply to the elevatory equipment described in following each item.</p> <p>(2) The escalators of special construction and special use form of which structural method designated by the minister of land, infrastructure, and transport; the provisions of Article 129-12, paragraph 1.</p>

EN 115-1 (Europe)	A17.1/B44 (North America)	Japanese codes
<p>1.2 This standard does not deal with hazards arising from seismic activities.</p>	<p>SECTION 8.5: ESCALATOR AND MOVING WALK SAFETY REQUIREMENTS FOR SEISMIC RISK ZONE 2 OR GREATER</p> <p>Requirement 8.5 applies to all escalators and moving walks installed in buildings that are designed and built to the requirements of, and located in, seismic risk zone 2, or greater, as defined by the building code (see 1.3).</p> <p>Where the applicable building code does not make reference to seismic risk zones, the ground motion parameters shown in 8.4.13 shall be used.</p> <p>The escalator and moving walk safety requirements contained in 8.5 shall be in addition to the requirements in the other parts of the code, unless otherwise specified.</p> <p>.....</p>	<p>MOC-N (No. 541-2009)</p> <p>The step roller shall not be dropped off from track rail by earthquakes and other vibrations.</p>
<p>1.3 This document is not applicable to escalators and moving walks which were manufactured before the date of its publication as EN. It is, however, recommended that existing installations be adapted to this standard.</p>	<p>1.3 Application of parts (of A17.1/B44)</p> <p>This code applies to new installations only, except Parts X, XII, and XIX which apply to both new and existing installations.</p> <p>Definitions:</p> <ul style="list-style-type: none"> - installation, new - any installation not classified as an existing installation by definition, or an existing elevator, dumbwaiter, escalator, material lift, inclined lift, or moving walk moved to a new location subsequent to the effective date of this code. - installation, existing - an installation that has been completed or is under construction prior to the effective date of this code. - installation placed out of service - an installation whose power feed lines have been disconnected from the mainline disconnect switch and an escalator or moving walks whose entrances have been permanently barricaded. 	<p>BSLJ; Art. 3, 3(3)</p>

EN 115-1 (Europe)	A17.1/B44 (North America)	Japanese codes
(1.4)	<p>6.1.3.14/6.2.3.17 Non-escalator/moving walk-related equipment. Components not used directly in connection with the escalator/moving walk are prohibited to be installed on, in, or through the escalator/moving walk.</p>	—
<p>2 Normative references The following documents, in whole or in part, are normatively referenced in this document and are indispensable for its application. For dated references, only the edition cited applies. For undated references, the latest edition of the referenced document (including any amendments) applies.</p>	<p>SECTION 4: REFERENCE CODES, STANDARDS, AND SPECIFICATIONS This section covers the codes, standards, and specifications incorporated in this code by reference, the specific editions which are applicable, and the rules of this code which reference each document [see Table 4(a)]. This section also lists the names and addresses of the organizations from which these documents may be procured [see Table 4(b)]. Only that portion of the code, standard, or specification as specified by the rule in this code is applicable.</p>	<p>JIS The following standards are cited in JIS A 4302 - 1992.....</p>
<p>3 Definitions 3.1 Terms and definitions For the purposes of this document, the terms and definitions given in ISO 12100-1:2003 and the following apply. 3.1.1 angle of inclination: maximum angle to the horizontal in which the steps, the pallets, or the belt move.</p>	—	—
<p>3.1.2 balustrade: part of the escalator/moving walk which ensures the user's safety by providing stability, protecting from moving parts, and supporting the handrail</p>	—	—
<p>3.1.3 balustrade decking: transverse member of the balustrade which meets the handrail guidance profile and which forms the top cover of the balustrade</p>	—	—
<p>3.1.4 brake load: load on the step/pallet/belt which the brake system is designed to stop the escalator/moving walk</p>	—	—
<p>3.1.5 a comb: pronged section at each landing that meshes with the grooves</p>	—	—

EN 115-1 (Europe)	A17.1/B44 (North America)	Japanese codes
3.1.5 b comb plate: platform at each landing to which the combs are attached	—	—
3.1.6 electrical safety system: safety related part of the electrical control system as an arrangement of safety circuits and monitoring devices	—	—
3.1.7 electrical safety devices: part of a safety circuit consisting of safety switches and/or fail safe circuits	—	—
<p>3.1.8 escalator: power-driven, inclined, continuous moving stairway used for raising or lowering persons in which the user carrying surface (e.g. steps) remains horizontal</p> <p>NOTE Escalators are machines even when they are out of operation and cannot be considered as fixed staircases.</p>	<p>SECTION 3: DEFINITIONS</p> <p>This section defines various terms used in this code. In addition, a number of other terms are defined for the standardization of nomenclature and terminology³⁾</p> <p><i>3) There are many more definitions in A 17.1 than is shown here. The ones shown here correspond to the definitions in EN 115.</i></p> <p>escalator - power-driven, inclined, continuous stairway used for raising or lowering passengers</p> <p>- escalator, conventional - an escalator on which the running gear is driven by a single drive shaft at a terminal</p> <p>- escalator, modular - an escalator on which the running gear along the incline is driven by one or more drive units</p>	<p>BSLJ-EO; Article 129-3,EXP. 1(2)</p> <p>The escalator means “power driven, continuous stairway or walkway for the transport of passengers”.</p>
3.1.9 exterior panel: part of the exterior side of the enclosure of an escalator or moving walk	—	—
3.1.10 fail safe circuit: safety related electrical and/or electronic system with defined failure mode behaviour	—	—
3.1.11 handrail: power-driven moving rail for persons to grip while using the escalator or moving walk	—	—
3.1.12 interior panel: panel located between the skirting or lower inner decking and the handrail guidance profile or balustrade decking	—	—
3.1.13 a lower inner decking: profile that connects the skirting with the interior panel when they do not meet at a common point	—	—

EN 115-1 (Europe)	A17.1/B44 (North America)	Japanese codes
3.1.13 b lower outer decking: profile that connects the exterior panels with the interior panel	—	—
3.1.14 machinery: escalator or moving walk machine(s) mechanisms and associated equipment	—	—
3.1.15 machinery spaces: space(s) inside or outside of the truss where the machinery as a whole, or in parts, is placed	—	—
3.1.16 maximum capacity: maximum flow of persons that can be achieved under operational conditions	—	—
<p>3.1.17 moving walk: power-driven installation for the conveyance of persons in which the user carrying surface remains parallel to its direction of motion and is uninterrupted (e.g. pallets, belt)</p> <p>NOTE Moving walks are machines even when they are out of operation and should not be used as a fixed access.</p>	<p>moving walk - a type of passenger-carrying device on which passengers stand or walk and in which the passenger-carrying surface remains parallel to its direction of motion and is uninterrupted</p> <p>- moving walk, belt pallet type - a moving walk with a series of connected and power-driven pallets to which a continuous belt treadway is fastened</p> <p>- moving walk, belt type - a moving walk with a power-driven continuous belt treadway</p> <p>- moving walk, edge supported belt type - a moving walk with the treadway supported near its edges by succession of rollers</p> <p>- moving walk, pallet type - a moving walk with a series of connected and power-driven pallets which together constitute the treadway</p> <p>- moving walk, roller bed type - a moving walk with the treadway supported throughout its width by a succession of rollers</p> <p>- moving walk, slider-bed type - a moving walk with the treadway sliding upon a supporting surface</p>	<p>BSLJ-EO; Article 129-3, EXP.1(2)</p> <p>The walkway (called passenger conveyor) means that the angle of inclination is equal to or less than 15° and the tread surface of pallets or belts, which the height difference between pallets is equal to or less than 4 mm, is horizontal or inclined.</p>
3.1.18 newel: end of the balustrade	—	—
3.1.19 nominal speed: speed in the direction of the moving steps, pallets, or the belt when operating the equipment under no load condition (i.e. without persons) stated by the manufacturer as that for which the escalator or moving walk has been designed	—	—

EN 115-1 (Europe)	A17.1/B44 (North America)	Japanese codes
<p>3.1.20 programmable electronic system in safety related applications for escalators and moving walks (PESSRAE): system for control, protection, or monitoring based on one or more programmable electronic devices including all elements of the system such as power supplies, sensors, and other input devices, data highways, and other communication paths and actuators and other output devices used in safety related applications as listed in Table 6.</p>	—	—
<p>3.1.21 rated load: load which the equipment is designed to move</p> <p>NOTE For maximum capacity, see Annex H.</p>	<p>rated load</p> <p>- <i>elevator, dumbwaiter, escalator, or inclined lift</i> - the load which the equipment is designed and installed to lift at the rated speed;</p> <p>- <i>moving walk</i> - the load which the moving walk is designed and installed to move, horizontally or at an incline at the rated speed</p>	—
<p>3.1.22 rise: vertical distance between the upper and lower finished floor levels</p>	—	—
<p>3.1.23 safety circuit: part of the electric safety system consisting of electrical safety devices</p>	—	—
<p>3.1.24 safety integrity level (SIL): discrete level for specifying the safety integrity requirements of the safety functions to be allocated to the PESSRAE</p> <p>NOTE In this European Standard, SIL 1 is representing the lowest level and SIL 3 the highest, even when it does not make use of SIL 3.</p>	—	—
<p>3.1.25 skirting: vertical part of the balustrade interfacing with the steps, pallets, or belt</p>	—	—
<p>3.1.26 skirt deflector: device to minimize the risk of trapping between the step and the skirting</p>	—	—
<p>3.1.27 stand-by operation: mode in which an escalator/ moving walk can be stopped or operated under no load condition with any speed below the nominal speed</p>	—	—

EN 115-1 (Europe)	A17.1/B44 (North America)	Japanese codes
<p>3.1.28 system reaction time: sum of the following two values:</p> <p>a) time period between the occurrence of a fault in the PESSRAE and the initiation of the corresponding action on the escalator/moving walk;</p> <p>b) time period for the escalator/moving walk to respond to the action maintaining a safe state</p>	—	—
(3.1.29)	<p>rated speed - the speed at which the elevator, dumbwaiter, escalator, moving walk, material lift, or inclined lift is designed to operate under the following conditions:</p> <p>- elevator, dumbwaiter, or material lift - the speed in the up direction with rated load in the car (also see operating speed in the down direction)</p> <p>- escalator or inclined lift - the rate of travel of the steps or carriage measured along the angle of inclination with rated load on the steps or carriage. In the case of a reversible escalator, the rated speed shall be the rate of travel of the steps in the up direction measured along the angle of inclination with rated load on the steps.</p> <p>- moving walk - the rate of travel of the treadway horizontally or at an incline with rated load on the treadway. In the case of reversible inclined moving walks, the rated speed is the rate of travel of the treadway in the up direction measured along the angle of inclination, with rated load on the treadway.</p>	<p>BSLJ-EO Article 129-12, EXP.1(5) Rated speed: Speed in the up direction of the moving steps, pallets, or the belt when operating the equipment under no load condition.</p>
(3.1.30)	<p><i>The A 17.1 is a safety code which applies equally to all escalators regardless of their use. The loading patterns and useful life of the equipment is a commercial issue and not one of safety.</i></p>	—
(3.31)	<p>controller - a device or group of devices which serves to control in a predetermined manner the apparatus to which it is connected.</p>	—

EN 115-1 (Europe)	A17.1/B44 (North America)	Japanese codes
(3.32)	driving machine - the power unit which applies the energy necessary to raise and lower an elevator, material lift, or dumbwaiter car, or to drive an escalator, an inclined lift, or a moving walk.	—
(3.33)	flat steps - the distance, expressed in step length, that the leading edge of the escalator step travels after emerging from the comb before moving vertically	—
(3.34)	landing - the stationary area at the entrance to or exit from an escalator/moving walk	—
(3.35)	pallet, moving walk - one of a series of rigid platforms which together form an articulated treadway or the support for a continuous treadway	—
(3.36)	slope, moving walk - the angle which the treadway makes with the horizontal	—
(3.37)	travel (rise) - the vertical distance between the bottom terminal landing and the top terminal landing of an elevator, dumbwaiter, escalator, material lift, or inclined lift.	—
(3.38)	treadway, moving walk - the passenger-carrying member of a moving walk.	—
(3.39)	width, moving walk - the exposed width of the treadway. 6.1.3.2/6.2.3.2 Geometry 6.1.3.2.1/6.2.3.2.1 The width of the escalator/moving walk shall be the width of step tread/exposed tread (see 6.1.3.5.2, for step width requirements, see 6.2.3.7)	—
3.2 Symbols and abbreviations See Table 1.	—	—
4 List of significant hazards This clause contains all the significant hazards, hazardous situations, and events, as far as they are dealt with in this standard, identified by risk assessment as significant for escalators and moving walks and which require action to eliminate or reduce the risk. These significant hazards are based upon ISO 14121-1.	—	—

EN 115-1 (Europe)	A17.1/B44 (North America)	Japanese codes
<p>5 Safety requirements and/or protective measures</p> <p>5.1 General</p> <p>Escalators and moving walks shall comply with the safety requirements and/or protective measures of this clause. In addition, escalators and moving walks shall be designed according to the principles of ISO 12100-2 for relevant, but not significant hazards which are not dealt with by this standard.</p> <p>Certain escalators and moving walks are subject to special operational and environmental conditions. For these cases, some additional recommendations are defined (see H.2).</p>	<p>—</p>	<p>—</p>
<p>5.2 Supporting structure(truss) and enclosure</p> <p>5.2.1 General</p> <p>5.2.1.1 All mechanically moving parts of the escalator or moving walk shall be completely enclosed within imperforate panels or walls. Exempt from this are the accessible steps, the accessible pallets, the accessible belt, and that part of the handrail available for the user. Apertures for ventilation are permitted (see also 5.2.1.5).</p>	<p>6.1.2.1/6.2.2.1 Protection required</p> <p>The sides and undersides of an escalator/moving walk truss or group of adjacent trusses in a single wellway shall be enclosed in materials defined as either non-combustible or limited-combustible by the building code or ANSI/NFPA 101¹⁾. Means provided for adequate ventilation of the driving machine and control spaces when included in the truss enclosure area shall be permitted.</p>	<p>—</p>

EN 115-1 (Europe)	A17.1/B44 (North America)	Japanese codes
	<p><i>1) The term "fire resistive materials" has been replaced with a specific specification to eliminate subjective interpretations by the enforcing authorities.</i></p> <p>6.1.3.3.1/6.2.3.3.1 Construction</p> <p>(b) The balustrade shall be totally closed except for the following:</p> <p>(1) where the handrail enters the newel base (see 6.1.3.4.3/6.2.3.4.2);</p> <p>(2) gaps between interior panels shall not be wider than 5 mm (0,19 in.). The edges shall be rounded or bevelled.</p> <p>6.1.3.6.6/6.2.3.8.5 Floor opening protection adjacent to escalator/moving walk wellway. Floor openings adjacent to the entire length of the escalator/moving walk wellway shall be provided with protection in accordance with the applicable building code (see Part 9).</p>	
<p>5.2.1.2 The exterior panels shall withstand a force of 250 N at any point at right angles on an area of 25 cm² without breakage or deflection resulting in any gap. The fixing shall be designed in that way to carry at least twice the dead load of the enclosure.</p>	<p><i>(defined in building codes)</i></p>	
<p>5.2.1.3 It is permissible to omit an enclosure of the mechanically moved parts if other measures (such as rooms with locked doors accessible to authorized personnel only) make a hazard to the public impossible.</p>	<p>—</p>	<p>—</p>
<p>5.2.1.4 Accumulation of materials (e.g. grease, oil, dust, paper) represents a fire risk. Therefore, it shall be possible to clean the inner part of the escalator/moving walk.</p>	<p>8.6.8/8.6.9 Maintenance of escalator/moving walks</p> <p>8.6.8.13/8.6.9.11 Cleaning. the interiors of escalators/moving walks, and their components shall be periodically cleaned to prevent an accumulation of oil, grease, lint, dirt, and refuse. The frequency of the cleaning will depend on service and conditions, but an inspection to determine if cleaning is necessary shall be required at least once a year.</p>	<p>—</p>

EN 115-1 (Europe)	A17.1/B44 (North America)	Japanese codes
<p>5.2.1.5 Ventilation apertures shall be built or arranged in such a way to comply with ISO 13857:2006, Table 5. However it shall not be possible to pass a straight rigid rod 10 mm in diameter through the enclosure and to touch any moving part through a ventilation aperture.</p>	<p>6.1.2.1/6.2.2.1 Protection required. The sides and undersides of an escalator/moving walk truss or group of adjacent trusses in a single wellway shall be enclosed in materials defined as either noncombustible or limited-combustible by the building code or ANSI/NFPA 101¹⁾. Means provided for adequate ventilation of the driving machine and control spaces when included in the truss enclosure area shall be permitted.</p>	<p>—</p>
<p>5.2.1.6 Any exterior panels which are designed to be opened (e.g. for cleaning purposes) shall be provided with an electric safety device according to Table 6 n).</p>	<p>There is no equivalent rule requiring a safety device. The following rule is closest to meet the requirement, but requires group 2 security.</p> <p>6.1.7.3.3/6.2.7.3.3 If access doors are provided in the side of the escalator/moving walk enclosure, they shall be kept closed and locked. The key shall be removed only when in the locked position. The key shall be of group 2 security (see 8.1).</p>	<p>—</p>
<p>5.2.2 Angle of inclination</p> <p>The angle of inclination, α, of the escalator shall not exceed 30°, but for rises, h_{13}, not exceeding 6 m and a nominal speed not exceeding 0,50 m/s, the angle of inclination is permitted to be increased up to 35° (see α in Figure 2).</p> <p>The angle of inclination of moving walks shall not exceed 12°.</p>	<p>6.1.3 Construction requirements</p> <p>6.1.3.1 Angle of inclination. The angle of inclination shall be designed not to exceed 30° from the horizontal, but due to field conditions at the site shall be permitted to exceed this maximum by 1°. The angle shall be measured at the centerline of the steps.</p> <p>6.2.3.1 Angle of inclination. The angle of inclination from the horizontal shall not exceed 3° within 900 mm (36 in.) of the entrance and egress ends and shall not exceed 12° at any point.</p>	<p>BSLJ-EO; Article 129-12</p> <p>1.(2) The inclination shall be 30° or less.</p> <p>BSLJ-EO; Article 129-12, EXP.1.(2)</p> <p>The inclination (slope) of the escalator shall be 30° or less.</p> <p>However, the inclination of 35° or less is permitted for the escalator as provided to MOC-N (No.1413-2000) 2-1. The inclination of 15° or less is permitted for the moving walks as provided to MOC-N (No.1417-2000)2.</p>

EN 115-1 (Europe)	A17.1/B44 (North America)	Japanese codes
		<p>MOC-N (No.1413-2000)</p> <p>2. The escalators of the special construction or the special use form to which the provisions described in the Art.129-3, item 3, paragraph 2 are not applied shall conform to the construction method specified in each paragraph come under the kind of the escalators described in following each paragraph.</p> <p>(1) The escalator of which inclination exceeding 30°.</p> <p>In addition to conforming to the provisions stipulated in Art.129-12, item 1, paragraph 1, 3, and 4, it shall conform to the construction specified as follows.</p> <p>(a) It shall be that the inclination is less than 35°.</p> <p>(2) The escalator of which step tread width exceeding 1,1 m.</p> <p>In addition to conforming to the provisions stipulated in Art.129-12, item 1, paragraph 1, 3, and 4, it shall conform to the construction specified as follows.</p> <p>(a) It shall be that the inclination is less than 4°.</p> <p>(3) The escalator of which speed varies in halfway of travel</p> <p>It shall be conform to the construction specified as follows.</p> <p>(e) Slope of the escalator shall be equal to or less than 4° at the position where the speed of step varies and shall be equal to or less than 8° at the position other than the part mentioned above.</p>
<p>5.2.3 Access to the interior</p> <p>Machinery spaces inside the truss shall only be accessible to authorized persons (e.g. by key, access control).</p>	<p>See 8.1.3 "Authorized personnel".</p>	<p>—</p>
<p>5.2.4 Inspection covers and floor plates</p> <p>Inspection covers and floor plates shall be provided with a control device according to Table 6 n).</p>	<p>6.1.7.3/6.2.7.3 Access to Interior.</p> <p>Reasonable access to the interior of the escalator/moving walk shall be provided for inspection and maintenance.</p>	<p>—</p>

EN 115-1 (Europe)	A17.1/B44 (North America)	Japanese codes
<p>It shall only be possible to open inspection covers and floor plates by a key or a tool suited for that purpose.</p> <p>If rooms behind inspection covers and floor plates can be entered, it shall be possible to open them from the inside without a key or a tool even when locked.</p>	<p>6.1.7.3.2/6.2.7.3.2 Access plates at the top and bottom landings shall be securely fastened by a mechanical means.</p> <p>6.1.7.3.3/6.2.7.3.3 If access doors are provided in the side of the escalator/moving walk enclosure, they shall be locked. The key shall be removable only when in the locked position. The key shall be of group 2 security (see 8.1)</p>	<p>—</p>
<p>Inspection doors and trap doors shall be imperforate and conform to the same conditions as required for the location where they are installed..</p>	<p>6.1.7.3.1/6.2.7.3.1 Access plates requiring no more than 70 lbf (311 N) effort to open shall be provided at the top and bottom landing/both landings for inspection and maintenance. The plates shall be made of a material which will afford a secure foothold. The use of stone, terrazzo, or concrete as a fill material is prohibited in panels within the confines of the escalator truss.</p>	<p>—</p>
<p>5.2.5 Structural design</p> <p>The supporting structure shall be designed in a way that it can support the dead weight of the escalator or moving walk plus a rated load of 5 000 N/m². It shall be calculated in accordance with EN 1993-1-1.</p> <p>NOTE Load carrying area = (nominal width z_1 (see Figure 3) of the escalator or moving walk) × (distance l_1 between the supports) (see Figure 2).</p>	<p>6.1.3.9/6.2.3.10 Rated load</p> <p><i>Rated loads are expressed in terms that apply to both linear and curved escalators.</i></p> <p>6.1.3.9.1 Structural. For the purpose of structural design, the rated load shall be considered to be not less than the following:</p> <p><i>(SI units)</i> Structural rated load (kg) = D_1 $(W + 203) A / 1\ 000$</p> <p><i>(Customary units)</i> Structural rated load (lb) = D_2 $(W + 8) A / 12$</p>	<p>BSLJ-E0; Article 129-12</p> <p>3. Carrying load for the escalators shall equal or exceed the values calculated by the following formula:</p> $P = 2\ 600\ \text{N/m}^2$ <p>where:</p> <p>P is the carrying load for the escalator, in Newtons;</p> <p>A is the horizontal projected area of the steps of the escalators, in square meters.</p>

EN 115-1 (Europe)	A17.1/B44 (North America)	Japanese codes
	<p>where:</p> <p>A = length of the horizontal projection of the entire truss measured along its centerline, m (ft);</p> <p>D_1 = loading factor = 270 kg/m²;</p> <p>D_2 = loading factor = 55.2 lb/ft²;</p> <p>W = width of the escalator, mm (in.) (see 6.1.3.2).</p> <p>6.2.3.10.1 Structural. For the purpose of structural design, the rated load shall be considered to be not less than the following:</p> <p><i>(SI units)</i> Structural rated load (kg) = $D_7 (W) A / 1\ 000$</p> <p><i>(Customary units)</i> Structural rated load (lb) = $D_8 (W) A / 12$</p> <p>where:</p> <p>A = length of the horizontal projection of the entire truss measured along its centerline, m (ft);</p> <p>D_7 = loading factor = 490 kg/m²;</p> <p>D_8 = loading factor = 100 lb/ft²;</p> <p>W = width of the moving walk, mm (in.) (see 6.2.3.2.1 and 6.2.3.7).</p> <p>6.2.3.10.2 Machinery</p> <p>(a) For the purpose of driving machine and power transmission calculations, the rated load for all single driving machines shall be considered to be not less than the following:</p> <p><i>(SI units)</i> Machinery rated load (kg) = $D_9 (W) C_1 / 1\ 000$</p> <p><i>(Imperial units)</i> Machinery rated load (lb) = $D_{10} (W) C_1 / 12$</p> <p>(b) The rated load per module for two or more modular driving machines shall be considered to be not less than the following:</p>	<p>MOC-N (No.1418-2000) 2(2)</p> <p>(2) In the Art.129-12, item 2, the safety factor of step, frame, and truss or beam stipulated in Art.129-4, item 2, paragraph 3 of the Building Standard Law Enforcement Order applied mutatis mutandis shall be not less than the value described in the following table.</p> <p>b. Truss or beam</p> <p>JEAS-1003B, <i>Escalator specifications.</i></p> <p>JEAS-1004B, <i>Structural calculation for escalator.</i></p>

EN 115-1 (Europe)	A17.1/B44 (North America)	Japanese codes
	<p>(SI units)</p> <p>Machinery rated load (kg) = $D_9 (W) C_2/1\ 000$</p> <p>(Imperial units)</p> <p>Machinery rated load (lb) = $D_{10} (W) C_2/12$</p> <p>where:</p> <p>C_1 = length of exposed treadway, m (ft);</p> <p>C_2 = length of exposed treadway per module, m (ft);</p> <p>D_9 = loading factor = 370 kg/m²;</p> <p>D_{10} = loading factor = 75.0 lb/ft²;</p> <p>W = width of the moving walk, mm (in.) (see 6.2.3.2.1 and 6.2.3.7).</p>	
—	<p>6.2.3.9 Supporting structure</p> <p>6.2.3.9.1 Supports Supports shall conform to the following:</p> <p>...</p> <p>(b) <i>Roller-Bed Type.</i> Where the treadway is supported on a series of rollers, the combination of roller spacing, belt tension, and belt stiffness shall be such that the deflection of the treadway surface, midway between rollers, shall not exceed the quantity 0,25 mm (0,094 in.) plus 0,004 times the centre-to-centre distance of rollers in mm (in.) when measured as follows.</p> <p>(1) The treadway surface shall be loaded midway between rollers with 11,3 kg (25 lb) weight concentrated on a cylindrical foot piece 50 mm (2 in.) long by 25 mm (1 in.) in diameter placed with its long axis across the belt. Deflection of this foot piece from its unloaded position shall not exceed the figure obtained above.</p> <p>(2) The rollers shall be concentric and true running within commercially acceptable tolerances.</p> <p>(d) <i>Pallet Type.</i> Pallet wheel tracks shall be so designed and located as to prevent more than 3 mm (0,125 in.) vertical displacement of the treadway should the pallet connection means break.</p>	—

EN 115-1 (Europe)	A17.1/B44 (North America)	Japanese codes																				
Based on passenger weight, the maximum calculated or measured deflection shall not exceed 1/750 of the distance between supports l_1 .	—	—																				
<p>Comparison of loads between EN 115 and A 17.1</p> <p>A 17.1 recognizes that fewer passengers can be placed on a moving escalator than can be accommodated on a stationary one. Therefore, two different rated loads are defined, one for the structural support, and one for the machinery that moves the passengers.</p> <p>The rated load is expressed differently in the two codes, but the table below shows the comparison in the same format, N/m of length. This is required since the width factor for the load carrying area in A 17.1 is the step width plus a constant.</p> <table border="1" data-bbox="336 723 922 936"> <thead> <tr> <th colspan="4">Rated load in N/m of length</th> </tr> <tr> <th>Step width</th> <th>600 mm</th> <th>800 mm</th> <th>1000 mm</th> </tr> </thead> <tbody> <tr> <td>EN 115</td> <td>3 000 N/m</td> <td>4 000 N/m</td> <td>5 000 N/m</td> </tr> <tr> <td>A 17.1 (Structural)</td> <td>2 202 N/m</td> <td>2 753 N/m</td> <td>3 304 N/m</td> </tr> <tr> <td>A 17.1 (Machinery)</td> <td>1 675 N/m</td> <td>2 095 N/m</td> <td>2 514 N/m</td> </tr> </tbody> </table>			Rated load in N/m of length				Step width	600 mm	800 mm	1000 mm	EN 115	3 000 N/m	4 000 N/m	5 000 N/m	A 17.1 (Structural)	2 202 N/m	2 753 N/m	3 304 N/m	A 17.1 (Machinery)	1 675 N/m	2 095 N/m	2 514 N/m
Rated load in N/m of length																						
Step width	600 mm	800 mm	1000 mm																			
EN 115	3 000 N/m	4 000 N/m	5 000 N/m																			
A 17.1 (Structural)	2 202 N/m	2 753 N/m	3 304 N/m																			
A 17.1 (Machinery)	1 675 N/m	2 095 N/m	2 514 N/m																			
(5.2.6)	<p>6.1.3.7 Trusses or girders. The truss or girder shall be designed to safely sustain the steps and running gear in operation. In the event of failure of the track system, it shall retain the running gear within the confines of this truss.</p> <p>Where tightening devices are operated by means of tension weights, provision shall be made to retain these weights in the truss if they should be released.</p>	—																				
<p>5.3 Steps, pallets, belt</p> <p>5.3.1 General</p> <p>In the user carrying area of the escalator, the step treads shall be horizontal with a tolerance of $\pm 1^\circ$ in the direction of travel.</p> <p>NOTE 1 The maximum permissible height between two consecutive steps at the landings is defined in 5.3.4 and 5.7.2.1.</p> <p>Tread surfaces for escalators and moving walks shall provide a secure foothold.</p> <p>NOTE 2 For definition of materials and test methods, see Annex J.</p>	<p>6.1.3.5.1 Material and type</p> <p>(c) Step treads shall be horizontal and shall afford a secure foothold. The step supporting system shall be so designed so that the back of the step cannot tip upward more than 6 mm (0,25 in.) at any point.</p> <p>6.2.3.5.5 Material and type</p> <p>(c) Pallet treads shall afford a secure foothold.</p>	—																				

EN 115-1 (Europe)	A17.1/B44 (North America)	Japanese codes
—	<p>6.1.3.5.1/6.2.3.5.5 Material and type</p> <p>(a) Step/pallet frames, treads, risers, and dynamic skirt panels excluding the step's/their attachments or inserts, shall be metal, except that magnesium alloys shall not be used or the materials in their end-use configuration shall have a flame spread index of 0 to 50 based on the tests conducted in accordance with the requirements of ASTM E 84, UL 723, NFPA 255, or CAN/ULC-S102.2, whichever is applicable (see Part 9).</p> <p>(b) Nonmetallic attachments and inserts (excluding wheels) shall be classified 94 HB or better in accordance with ANSI/UL 94.</p>	—
—	<p>6.1.3.5.8/6.2.3.5.6 Step/pallet wheels. Where support wheels attached to the steps/pallets are not located within the width of the step/pallet, provision shall be made to prevent the step/pallet from falling into the escalator/moving walk interior due to a loss of one or more of the support wheel assemblies.</p>	—
<p>5.3.2 Dimensions</p> <p>5.3.2.1 General</p> <p>For escalators and moving walks, the nominal width, z_1, shall be not less than 0,58 m and not exceed 1,10 m.</p> <p>For moving walks with an angle of inclination up to 6°, widths up to 1,65 m are permitted.</p>	<p>6.1.3.5.2 Dimensions of steps. The depth of any step tread in the direction of travel shall be not less than 400 mm (15,75 in.), and the rise between treads shall be not more than 220 mm (8,5 in.). The width of a step tread shall be not less than 560 mm (22 in.) nor more than 1 020 mm (40 in.). (see Nonmandatory Appendix I, Fig. I-7.)</p> <p>6.2.3.7 Width. The width of a moving walk (see 6.2.3.2.1) shall be not less than 560 mm (22 in.). The maximum width shall depend both on the maximum slope at the point on the treadway and on the treadway speed. The width shall not exceed the value shown in Table 6.2.3.7.</p>	<p>BSLJ-EO; Article 129-12</p> <p>1.(4) The width of the steps shall be not more than 1,1 m and the horizontal distance between the side edge of the steps and centre of the handrail at the said side of the steps shall be not more than 25 cm.</p> <p>BSLJ-EO; Article 129-12</p> <p>EXP 1.(4) The width of the steps shall be not more than 1,1 m and the horizontal distance between the side edge of the steps and center of the handrail at the said side of the steps shall be not more than 25 cm (i.e. distance between handrails is no more than 1,6 m)</p> <p>The width of the steps for moving walk with inclination less than 4° is less than 1,6 m and distance from side edge of step to centre of handrail is not more than 0,25 m (i.e. distance between handrails is not more than 2,1 m).</p>

EN 115-1 (Europe)	A17.1/B44 (North America)	Japanese codes
		<p>(MOC-N(No.1413-2000) 2-2.)</p> <p>2. The escalators of the special construction or the special use form to which the provisions described in the Art.129-3, item 3, paragraph 2 are not applied shall conform to the construction method specified in each paragraph come under the kind of the escalators described in following each paragraph.</p> <p>(2) The escalator of which step tread width exceeding 1,1 m.</p> <p><i>In addition to conforming to the provisions stipulated in the Art. 129-12, item 1, paragraph 1, 3, and 4, it shall conform to the construction specified as follows.</i></p> <p>(c) It shall be that the width of the step is less than 1,6 m and the horizontal distance between the said edge of the step and centre of the handrail of the said side of the step is less than 25 cm.</p> <p>(3) The escalator of which speed varies in halfway of travel.</p> <p>(f) Width of a step shall be equal to or less than 1,6 m. Horizontal displacement between the side of a step and the centre of an upper surface of handrail on the same side of the said step shall be equal to or less than 25 cm.</p>
<p>5.3.2.2 Step treads and pallets (see Figure 2, detail X, and Figure 5)</p> <p>5.3.2.2.1 The step height, x_1, shall not exceed 0,24 m.</p> <p>5.3.2.2.2 The step depth, y_1, shall be not less than 0,38 m.</p>	<p>6.1.3.5.2 Dimensions of steps. The depth of any step tread in the direction of travel shall be not less than 400 mm (15,75 in.) and the rise between treads shall be not more than 220 mm (8,5 in.). The width of a step tread shall be not less than 560 mm (22 in.) nor more than 1 020 mm (40 in.) (see Nonmandatory Appendix I, Fig. I-7).</p>	<p>2. The escalators of the special construction or the special use form to which the provisions described in the Art.129-3, item 3, paragraph 2 are not applied shall conform to the construction method specified in each paragraph come under the kind of the escalators described in following each paragraph</p> <p>(1) The escalator of which inclination exceeding 30°.</p> <p><i>In addition to conforming to the provisions stipulated in the Art. 129-12, item 1, paragraph 1, 3, and 4, it shall conform to the construction specified as follows.</i></p> <p>(d) It shall be that the depth of the step is more than 35 cm.</p>

EN 115-1 (Europe)	A17.1/B44 (North America)	Japanese codes
<p>5.3.2.2.3 The surface of the step treads and pallets shall have grooves in the direction of movement with which the teeth of the combs mesh.</p>	<p>6.1.3.5.5/6.2.3.5.1 Slotting of step treads/treadway. The tread/treadway surface of each step/pallet shall be slotted in a direction parallel to the travel of the steps/to its travel.</p>	<p>—</p>
<p>5.3.2.2.4 The step risers shall be cleated and the surface of the cleat shall be smooth. The ends of the step tread shall mesh with the cleating of the next step riser.</p>	<p>6.1.3.5.3 Cleated step risers. The step riser shall be provided with vertical cleats which shall mesh with slots on the adjacent step tread wherever the steps are exposed (see Nonmandatory Appendix I, Fig. I-8).</p>	<p>—</p>
<p>5.3.2.2.5 The width, b_7, of the grooves shall be at least 5 mm and not exceed 7 mm.</p> <p>5.3.2.2.6 The depth, h_7, of the grooves shall be not less than 10 mm.</p> <p>5.3.2.2.7 The web width, b_8, shall be at least 2,5 mm and not exceed 5 mm.</p>	<p>6.1.3.5.5 Slotting of step treads. Each slot shall be not more than 6,5 mm (0,25 in.) wide and not less than 9,5 mm (0,375 in.) deep and the distance from centre to centre of adjoining slots shall be not more than 9,5 mm (0,375 in.).</p> <p>6.2.3.5.1 Slotting of treadway. Each slot shall be not more than 6,5 mm (0,25 in.) wide at the treadway surface and not less than 9,5 mm (0,375 in.) deep and the distance from centre to centre of adjoining slots shall be not more than 9,5 mm (0,375 in.). Sides of the slots shall be permitted to slope for mould draft purposes and shall be permitted to be filleted at the bottom (see Nonmandatory Appendix I, Fig. I-10).</p>	<p>—</p>
<p>5.3.2.2.8 The step treads and step risers or pallets shall not finish with a groove at their side edges.</p>	<p>6.1.3.5.5 Slotting of step treads.</p> <p>... Slots shall be so located on the step tread surface as to form a cleat on each side of the step tread adjacent to the skirt or dynamic skirt panel (see Nonmandatory Appendix I, Fig. I-7).</p> <p>6.2.3.5.1 Slotting of treadway.</p> <p>... Slots shall be so located on each side of the pallet to form a cleat adjacent to the skirt panel (see Nonmandatory Appendix I, Fig. I-10).</p>	<p>—</p>
<p>5.3.2.2.9 The edge between the surface of the step tread and the riser shall have any sharpness relieved.</p>	<p>—</p>	<p>—</p>

EN 115-1 (Europe)	A17.1/B44 (North America)	Japanese codes
<p>5.3.2.3 Belts (see Figure 2, detail X)</p> <p>5.3.2.3.1 The belts shall have grooves in the direction of travel with which the teeth of the comb mesh.</p> <p>5.3.2.3.2 The width, b_7, of the grooves shall be at least 4,5 mm and not exceed 7 mm, and shall be measured at the tread surface of the belt.</p> <p>5.3.2.3.3 The depth, h_7, of the grooves shall be not less than 5 mm.</p> <p>5.3.2.3.4 The web width, b_8, shall be at least 4,5 mm and not exceed 8 mm and shall be measured at the tread surface of the belt.</p>	<p>6.2.3.6.2 Slotting of treadway. The treadway surface shall be slotted in a direction parallel to its travel for purposes of meshing with combplates at the landings. Each slot shall be not more than 6,4 mm (0,25 in.) wide at the treadway surface and not less than 4,8 mm (0,188 in.) deep and the distance from centre to centre of adjoining slots shall be not more than 13 mm(0,50 in.). Sides of slots shall be permitted to slope for mould draft purposes and shall be permitted to be filleted at the bottom. Slots shall be so located on each side of the belt to form a cleat adjacent to the skirt panel.</p>	—
<p>5.3.2.3.5 The belt shall not finish with a groove at the side edge of the belt.</p> <p>Splicing of the treadway belt shall be such as to provide a continuous unbroken treadway surface.</p>	<p>6.2.3.6.2 Slotting of treadway. Slots shall be so located on each side of the belt to form a cleat adjacent to the skirt panel.</p> <p>6.2.3.6.1 Splices. splicing of the treadway belt shall be made in such a manner as to result in a continuous unbroken treadway surface of the same characteristics as the balance of the belt.</p>	—
—	—	—

EN 115-1 (Europe)	A17.1/B44 (North America)	Japanese codes
<p>5.3.3 Structural design</p> <p>5.3.3.1 General</p> <p>The materials shall retain their strength characteristics during their specified life cycle taking into account the environmental conditions, e.g. temperature, ultraviolet radiation, humidity, corrosion.</p> <p>The steps, pallets, and the belt shall be designed to withstand all possible loading and distortion effects which may be imposed by the tracking, guiding, and driving system during normal operation and shall be designed to support an equally distributed load corresponding to 6 000 N/m²</p> <p>NOTE 6 000 N/m² is derived from a static load of 5 000 N/m² (see 5.2.5) plus an impact factor of 1,2.</p> <p>To establish the dimensions of the belt and its supporting system, an area of effective width × 1,0 m length shall be taken as a basis for this corresponding load (in addition the requirements of 5.3.3.2.4 shall be complied with).</p> <p>Assembled steps and pallets shall be designed such that all component parts, e.g. inserts or fixings are securely attached and do not become loose during their life cycle. The inserts and fixings shall withstand the reaction force of operating the comb/comb plate electric safety device [Table 6 g)].</p>	<p>6.1.3.9.4 Step. The step shall be designed to support a load of 135 kg (300 lb) on a 150 mm × 250 mm (6 in. × 10 in.) plate placed on any part of the step with the 250 mm (10 in.) dimension in the direction of step travel.</p> <p>6.2.3.10.4 Pallet. The pallet shall be designed to support a load of 135 kg (300 lb) for each 0,42 m² (4.5 ft²) of area or part thereof. The load shall be applied on a 150 mm × 250 mm (6 in. × 10 in.) plate placed on any part of the pallet with the 250 mm (10 in.) dimension in the direction of step travel. If more than one load is required, they shall be located no closer than 910 mm (36 in.) to each other.</p> <p>6.1.3.10.4/6.2.3.11.4 For steps/pallets, the factor of safety shall be 5 based on not less than the loads designated in 6.1.3.9.4/6.2.3.10.4.</p>	<p>(Same text as in the row related to EN 115-1, 5.2.5 applies also for step and frame in MOC-N (No. 1418-2000, 2a)</p> <p>JEAS-1003B, <i>Escalator specifications.</i></p> <p>JEAS-1004B, <i>Structural calculation for escalator.</i></p>
<p>5.3.3.2 Static test</p> <p>5.3.3.2.1 Steps</p> <p>The step shall be tested for deflection with a single force of 3 000 N (including weight of the plate) applied perpendicular to the tread surface on a steel plate 0,20 m × 0,30 m in size and at least 25 mm thick in the centre of the tread surface. The edge of the plate being 0,20 m long shall be arranged parallel to the front edge of the step the edge of the plate being 0,30 m long at right angles to the front edge of the step.</p>	<p>—</p>	<p>—</p>

EN 115-1 (Europe)	A17.1/B44 (North America)	Japanese codes
<p>During this test, the deflection measured at the tread surface shall be not more than 4 mm. There shall be no permanent deformation (initial setting tolerances are permitted).</p> <p>The step shall be tested as a whole together with rollers (not rotating), axles, or stub shafts (if existing) in a horizontal position (horizontal support) and at the maximum inclination (inclined support) for which the step is to be applied.</p> <p>For all inclinations smaller than the maximum inclination permitted, a new test is not required. A test of the installed step, i.e. together with the guide rails and the supporting structure of the escalator, is also not necessary.</p>		
<p>5.3.3.2.2 Step riser</p> <p>The riser shall not deflect by more than 4 mm when subjected to a single load of 1 500 N applied normal to the surface on an area of 25 cm² using a square or round steel plate minimum thickness 25 mm shaped to fit the risers curvature. This load shall be applied in three positions across the width of the riser on the centre line, in the middle, and at both ends. There shall be no permanent deformation.</p>	—	—

EN 115-1 (Europe)	A17.1/B44 (North America)	Japanese codes
<p>5.3.3.2.3 Pallets</p> <p>The pallet shall be tested for deflection with a single force which, for a pallet area of 1 m², shall be 7 500 N (including weight of the plate). The force shall be applied perpendicular to the tread surface on a steel plate 0,30 m × 0,45 m in size and at least 25 mm thick in the centre of the tread surface and the edge of the plate being 0,45 m long shall be arranged parallel to the lateral edge of the pallet.</p> <p>For pallets with smaller or larger areas, the force and the loading area shall be changed proportionally, whereby, for the loading area, the ratio of edge length shall be 1:1,5, however, the force shall be not below 3 000 N (including weight of the plate), the size of the plate be not smaller than 0,20 m × 0,30 m and its thickness be not less than 25 mm.</p> <p>For pallets with a depth smaller than 0,30 m, the plate width shall be 0,20 m and the length of the plate shall be the depth of the pallet.</p> <p>During this test, the deflection measured at the tread surface shall be not more than 4 mm. There shall be no permanent deformation (initial setting tolerances are permitted).</p> <p>The pallet shall be tested as a whole together with rollers (not rotating), axles, or stub shafts (if existing) in a horizontal position. A test of the installed pallet, i.e. together with the guide rails and the supporting structure of the moving walk, is not required.</p>	<p>—</p>	<p>—</p>

EN 115-1 (Europe)	A17.1/B44 (North America)	Japanese codes
<p>5.3.3.2.4 Belts</p> <p>With the belt tensioned to suit operational conditions, a single force of 750 N (including weight of the plate) shall be applied on a steel plate 0,15 m × 0,25 m × 0,025 m in size. The plate shall be placed centrally between the edge supporting rollers in such a way that its longitudinal axis is parallel to the longitudinal axis of the belt. The deflection at the centre shall not exceed 0,01 z₃, where z₃ is the transverse distance between the supporting rollers (see z₃ in Figure 8).</p>	<p>6.2.3.9.1 Supports. Supports shall conform to the following:</p> <p>(c) <i>Edge-supported belt type.</i> When the treadway belt is transversely rigid and is supported by rollers along its edges, the following requirement shall apply:</p> <p>(1) With the belt tensioned through the take-up system, the permissible slope of a straight line from the top of a treadway rib adjacent to the centerline of the treadway to the top of a treadway rib adjacent to the balustrade in a plane perpendicular to the path of the treadway shall not exceed 3 % when the treadway is loaded with a 68 kg (150 lb) weight on a 150 mm × 250 mm (6 in. × 10 in.) plate located on the centerline of the treadway with the 250 mm (10 in.) dimension in the direction of treadway travel.</p>	—
<p>5.3.3.3 Dynamic tests</p> <p>5.3.3.3.1 Steps</p> <p>5.3.3.3.1.1 Load test</p> <p>The step shall be tested at the maximum inclination (inclined support) for which it is to be applied together with rollers (not rotating), axles, or stub shafts (if existing). It shall be subjected to a load pulsating between 500 N and 3 000 N at one frequency between 5 Hz and 20 Hz for at least 5 × 10⁶ cycles, whereby an undisturbed sinusoidal force flow shall be achieved. The load shall be applied perpendicular to the tread surface on a steel plate 0,20 m × 0,30 m in size and at least 25 mm thick arranged as specified</p>	<p>6.1.3.5.7 Step fatigue tests. Each step width shall be subjected to the step fatigue test as described in 8.3.11.</p> <p>8.3.11 Step and pallet fatigue engineering test</p> <p>Step fatigue tests required in 6.1.3.5.7 and pallet fatigue tests required by 6.2.3.5.4 shall be performed as indicated in 8.3.11.1 through 8.3.11.6.</p> <p>8.3.11.1 The test shall be made at either the manufacturer's facility or at a testing laboratory.</p> <p>8.3.11.2 Escalator steps shall be mounted in an arrangement that duplicates the conditions on the escalator incline and their attachment to the step chain.</p>	—

EN 115-1 (Europe)	A17.1/B44 (North America)	Japanese codes
<p>in 5.3.3.2.1 in the centre of the tread surface.</p> <p>After the test, the step shall show no indication of crack initiation.</p> <p>Permanent deformation shall not be greater than 4 mm measured at the tread surface. Steps or their component parts, e.g. inserts or fixings, shall be securely attached and not become loose.</p> <p>If rollers are damaged during the test, it is permissible to replace them.</p>	<p>8.3.11.3 The steps shall be subjected to a load varying from 450 N (100 lbf) to 3 000 N (650 lbf) at a frequency of 10 Hz ± 5 Hz for 5 000 000 cycles. An undisturbed harmonic force flow shall be achieved.</p> <p>8.3.11.4 The load shall be applied normal to the tread surface to a plate 25 mm (1 in.) thick, 200 mm (8 in.) wide, and 300 mm (12 in.) long, located at the centre of the step or pallet with the 300 mm (12 in.) dimension in the direction of step travel.</p> <p>8.3.11.5 The step or pallet shall have no fractures or permanent tread surface deflection exceeding 4 mm (0,16 in.) following the completion of the test. The deflection of 4 mm (0,16 in.) does not include any set or wear in the supporting wheels.</p> <p>8.3.11.6 This test is to be performed on each step or pallet width.</p>	
<p>5.3.3.3.1.2 Torsional test</p> <p>The step design shall be such that the structure can accommodate torsional loading equivalent to a ±2 mm displacement of the trailer wheel centre moving in an arc whose centre is the chain wheel centre. The ±2 mm displacement is a relative to a trailer wheel to chain wheel centre distance of 400 mm. This ratio shall be maintained when the 400 mm dimension is varied (see Annex F for test examples).</p> <p>The dynamic test shall be adjustable to ensure that the specified deflections above are achieved throughout the test. It shall be applied with one frequency between 5 Hz and 20 Hz for at least 5 × 10⁶ cycles, whereby an undisturbed sinusoidal force flow shall be achieved.</p> <p>After the test, the step shall show no indication of crack initiation.</p> <p>Permanent deformation shall not be greater than 4 mm measured at the tread surface. Steps or their component parts, e.g. inserts or fixings, shall be securely attached and not become loose.</p>	<p>—</p>	<p>—</p>

EN 115-1 (Europe)	A17.1/B44 (North America)	Japanese codes
<p>5.3.3.3.2 Pallets</p> <p>5.3.3.3.2.1 Load test</p> <p>The pallet, irrespective of its size, shall be tested in a horizontal position together with rollers (not rotating), axles, or stub shafts (if existing). It shall be subjected to a load pulsating between 500 N and 3 000 N at one frequency between 5 Hz and 20 Hz for at least 5×10^6 cycles, whereby an undisturbed sinusoidal force flow shall be achieved. It shall be applied perpendicular to the tread surface on a steel plate 0,20 m \times 0,30 m in size and at least 25 mm thick, in the centre of the tread surface.</p> <p>For pallets with a smaller length than 0,30 m, the plate width shall be 0,20 m and the length of the plate shall be the length of the pallet.</p> <p>After the test, the pallet shall show no indication of crack initiation.</p> <p>Permanent deformation shall not be greater than 4 mm measured at the tread surface. Pallets or their component parts, e.g. inserts or fixings, shall be securely attached and not become loose.</p> <p>If rollers are damaged during the test, it is permissible to replace them.</p>	<p>6.2.3.5.4 Pallet fatigue tests. Each pallet width shall be subjected to the pallet fatigue test as described in 8.3.11.</p> <p>8.3.11 Step and pallet fatigue engineering test.</p> <p>Step fatigue tests required in 6.1.3.5.7 and pallet fatigue tests required by 6.2.3.5.4 shall be performed as indicated in 8.3.11.1 through 8.3.11.6.</p> <p>8.3.11.1 The test shall be made at either the manufacturer's facility or at a testing laboratory.</p> <p>8.3.11.2 Moving walk pallets shall be mounted in an arrangement that duplicates the condition of a horizontal moving walk and their attachment to the pallet chain.</p> <p>8.3.11.4 The load shall be applied normal to the tread surface to a plate 25 mm (1 in.) thick, 200 mm (8 in.) wide, and 300 mm (12 in.) long located at the centre of the step or pallet with the 300 mm (12 in.) dimension in the direction of step travel.</p> <p>8.3.11.5 The step or pallet shall have no fractures or permanent tread surface deflection exceeding 4 mm (0.16 in.) following the completion of the test. The deflection of 4 mm (0,16 in.) does not include any set or wear in the supporting wheels.</p> <p>8.3.11.6 This test is to be performed on each step or pallet width.</p>	—

EN 115-1 (Europe)	A17.1/B44 (North America)	Japanese codes
<p>5.3.3.3.2.2 Torsional test</p> <p>A torsional test is only required if the pallets are fitted with trailer rollers.</p> <p>The pallet design shall be such that the structure can accommodate torsional loading equivalent to a ± 2 mm displacement of the trailer wheel centre moving in an arc whose centre is the chain wheel centre. The ± 2 mm displacement is related to a trailer wheel to chain wheel centre distance of 400 mm. This ratio shall be maintained when the 400 mm dimension is varied (see Annex F for test examples).</p> <p>The dynamic load shall be adjusted to achieve a deflection with a tolerance of - 5 % during the test. It shall be applied with one frequency between 5 Hz and 20 Hz for at least 5×10^6 cycles, whereby an undisturbed sinusoidal force flow shall be achieved.</p> <p>For pallets with a smaller length than 0,30 m, the plate width shall be 0,20 m and the length of the plate shall be the length of the pallet.</p> <p>After the test, the pallet shall show no indication of crack initiation.</p> <p>Permanent deformation shall not be greater than 4 mm measured at the tread surface. Pallets or their component parts, e.g. inserts or fixings, shall be securely attached and not become loose.</p>	<p>—</p>	<p>—</p>

EN 115-1 (Europe)	A17.1/B44 (North America)	Japanese codes
<p>5.3.4 Guiding of steps, pallets, and belt</p> <p>The lateral displacement of the steps or pallets out of their guiding system shall not exceed 4 mm at either side and 7 mm for the sum of clearances measured at both sides and the vertical displacement shall not exceed 4 mm for steps and pallets and 6 mm for belts.</p> <p>This requirement applies only to the usable area of the steps, pallets, or belt.</p>	<p>6.1.3.8 Step wheel tracks</p> <p>Step wheel tracks shall be designed so as to prevent displacement of the steps and running gear if a step chain breaks.</p> <p>(3) <i>Edge supported belt.</i> When the treadway belt is transversely rigid and is supported by rollers along its edges, the following requirement shall apply:</p> <p>(a) with the belt tensioned through the take-up system, the permissible slope of a straight line from the top of a treadway rib adjacent to the centerline of the treadway to the top of a treadway rib adjacent to the balustrade in a plane perpendicular to the path of the treadway shall not exceed 3 % when the treadway is loaded with a 150 lb (68 kg) weight on a 6 in. (152 mm) by 10 in. (254 mm) plate located on the centerline of the treadway with the 10 in. (254 mm) dimension in the direction of treadway travel.</p>	<p>—</p>
<p>Treadway supports for belts shall be provided at intervals not exceeding 2 m along the centre line of the treadway. These supports shall be located at a level not more than 50 mm below the underside of the treadway when it is loaded under the conditions required by 5.3.3.2.4.</p>	<p>6.2.3.9.1 Supports. Supports shall conform to the following:</p> <p>(c) <i>Edge-supported belt type.</i> When the treadway belt is transversely rigid and is supported by rollers along its edges, the following requirement shall apply:</p> <p>...</p> <p>(2) in order to support the treadway in case of localized overload, supports shall be supplied at intervals, not exceeding 1 830 mm (72 in.) along the centerline of the treadway. The supports shall be located at a level not more than 50 mm (2 in.) below the underside of the treadway when it is loaded under test conditions required by 6.2.3.9.1(c)(1).</p>	<p>—</p>
<p>—</p>	<p>—</p>	<p>—</p>
<p>—</p>	<p>—</p>	<p>—</p>
<p>—</p>	<p>—</p>	<p>—</p>
<p>—</p>	<p>6.2.3.5.3 Alignment of pallet tread surfaces. Adjacent ends of pallets shall not vary in elevation more than 1,6 mm (0.,06 in.).</p>	<p>—</p>

EN 115-1 (Europe)	A17.1/B44 (North America)	Japanese codes
<p>5.3.5 Clearance between steps or pallets</p> <p>The clearance between two consecutive steps or pallets in any usable position measured at the tread surface shall not exceed 6 mm (see Figure 2, details Y, Z; Figure 6, detail S; and Figure 7, detail U).</p> <p>Demarcation (e.g. groove in the step tread) shall be provided to highlight at the landings the rear edge of the steps.</p> <p>In the area of the transition curves of moving walks with meshed front edges and rear edges of the pallets, this clearance is permitted to be increased to 8 mm (see Figure 7, detail V).</p>	<p>6.1.3.5.4 Clearance between steps. The maximum clearance between step treads on the horizontal run shall be 6 mm (0,25 in.) (see Nonmandatory Appendix I, Fig. I-6).</p> <p>6.2.3.5.2 Intermeshing pallets. Alternate cleats on adjacent pallets shall intermesh so that there is no continuous transverse gap between adjacent pallets.</p>	<p>MOC-N (No.1413-2000)</p> <p>2. The escalators of the special construction or the special use form to which the provisions described in the Art.129-3, item 3, paragraph 2 are not applied, it shall conform to the construction method specified in each paragraph come under the kind of the escalators described in following each paragraph.</p> <p>(3) The escalator of which speed varies in halfway of travel.</p> <p>It shall conform to the construction specified as follows.</p> <p>(b) It shall be that the clearance between the side edge of the step and skirt guard panel is not more than 5 mm.</p> <p>(c) It shall be that the clearance between the adjacent steps is not more than 5 mm.</p> <p>MOC-N (No.1417-2000)</p> <p>(2) It shall be that the clearance between the side edge of the step and skirt guard panel is not more than 5 mm.</p> <p>(3) It shall be that the clearance between the adjacent steps is not more than 5 mm.</p> <p>JIS A 4302-2006;</p> <p>5.4.2(h) ≤ 5 mm</p> <p>JIS A 4302-2006</p> <p>5.4.2 (k) Demarcation shall be provided to highlight.</p>
<p>5.3.6 Missing step or pallet device</p> <p>A missing step/pallet [see Table 6 k)] shall be detected and the escalator/moving walk stopped before the gap (resulting from the missing step/pallet) emerges from the comb. This shall be ensured by a device provided at each driving and return station.</p>	<p>6.1.6.5 Missing step/pallet and missing dynamic skirt devices</p> <p>(a) A device shall be provided to detect a missing step/pallet and bring the escalator/moving walk to a stop before the gap resulting from the missing step/pallet emerges from the comb. The device shall cause power to be removed from the driving-machine motor and brake. The device shall be of the manual-reset type.</p>	<p>—</p>

EN 115-1 (Europe)	A17.1/B44 (North America)	Japanese codes
—	(b) For escalators with dynamic skirts, a device shall be provided to detect a missing dynamic skirt panel and bring the escalator to a stop before the gap resulting from the missing dynamic skirt panel emerges from the balustrade. The device shall cause power to be removed from the driving-machine motor and brake. The device shall be of the manual-reset type.	—
<p>5.4 Drive unit</p> <p>5.4.1 Driving machine</p> <p>5.4.1.1 General</p> <p>A drive unit shall not operate more than one escalator or moving walk.</p>	<p>6.1.5.2/6.2.5.2 Driving motor</p> <p>An electric motor shall not drive more than one escalator/moving walk driving machine. A driving machine shall not operate more than one escalator/moving walk.</p>	—
<p>5.4.1.2 Speed</p> <p>5.4.1.2.1 The nominal speed shall not deviate by more than $\pm 5\%$ at nominal frequency and nominal voltage.</p> <p>5.4.1.2.2 The nominal speed of the escalator shall not exceed to the following:</p> <ul style="list-style-type: none"> - 0,75 m/s for an escalator with an angle of inclination α up to 30°; - 0,50 m/s for an escalator with an angle of inclination α of more than 30° up to 35°. 	<p style="text-align: center;">—</p> <p>6.1.4 Rated Speed</p> <p>6.1.4.1 Limits of speed.</p> <p>6.1.4.1.1 The rated speed shall be not more than 0,5 m/s (100 ft/min) measured along the centerline of the steps in the direction of travel.</p> <p>The speed attained by an escalator after start-up shall not be intentionally varied, except as permitted by 6.1.4.1.2.</p> <p>6.1.4.1.2 Variation of the escalator speed after start-up shall be permitted provided the escalator installation conforms to all of the following:</p> <ul style="list-style-type: none"> (a) the acceleration and deceleration rates shall not exceed 0.3 m/s^2 ($1,0 \text{ ft/sec}^2$); (b) the rated speed is not exceeded; (c) the minimum speed shall be not less than 0,05 m/s (10 ft/min); (d) the speed shall not automatically vary during inspection operation; (e) passenger detection means shall be provided at both landings of the escalator such that <p>(1) detection of any approaching passenger shall cause the escalator to accelerate to or maintain the full</p>	<p>JIS A 4302-2006, 5.4.1 (b)</p> <p>The measured speed shall be not exceed 110 % of nominal speed under no load condition at landing.</p> <p>BSLJ-EO (Construction of Escalators)</p> <p>Article 129-12</p> <p>1. (5) The rated speed of the steps shall be not more than the speed per minute designated by the minister of land, infrastructure, and transport according to the inclination of the escalators within the limit of not more than 50m/min.</p> <p>MOC-N (No.1413-2000)</p> <p>2. The escalators of the special construction or the special use form to which the provisions described in the Art.129-3, item 3, paragraph 2 are not applied, it shall conform to the construction method specified in each paragraph come under the kind of the escalators described in following each paragraph.</p> <p>(1) The escalator of which inclination exceeding 30°.</p> <p>In addition to conforming to the provisions stipulated in the Art.129-12, item 1, paragraph 1, 3, and 4, it shall conform to the construction specified as follows.</p> <p>(b) It shall be that the rated speed of the step is less than 30m/min.</p>

EN 115-1 (Europe)	A17.1/B44 (North America)	Japanese codes
	<p>escalator speed conforming to 6.1.4.1.2(a) through (d);</p> <p>(2) detection of any approaching passenger shall occur sufficiently in advance of boarding to cause the escalator to attain full operating speed before a passenger walking at normal speed [1,35 m/s (270 ft/min)] reaches the combplate;</p> <p>(3) passenger detection means shall remain active at the egress landing to detect any passenger approaching against the direction of escalator travel and shall cause the escalator to accelerate to full rated speed and sound the alarm (see 6.1.6.3.1) at the approaching landing before the passenger reaches the combplate;</p> <p>(f) automatic deceleration shall not occur before a period of time has elapsed since the last passenger detection that is greater than three times the amount of time necessary to transfer a passenger between landings;</p> <p>(g) means shall be provided to detect failure of the passenger detection means and shall cause the escalator to operate at full rated speed only.</p>	<p>EXP. 2.(1) Rated speed is stipulated corresponding to inclination</p> <p>[see Table C.6 in the Annex of this comparison]</p> <p>MOC-N (No.1417-2000) EXP. 2.(1) and (2)</p> <p>Rated speed is stipulated corresponding to inclination.</p> <p>[see Table C.7 in the Annex of this comparison]</p>
<p>5.4.1.2.3 The nominal speed of moving walks shall be not higher than 0,75 m/s.</p> <p>Deviating from above, a nominal speed up to 0,90 m/s is permitted provided the width of the pallets or the belt does not exceed 1,10 m and at the landings, the pallets or the belt move horizontally for a length of at least 1,60 m before entering the combs.</p>	<p>6.2.4 Rated speed</p> <p>The maximum speed of a treadway shall depend on the maximum slope at any point on the treadway. The speed shall not exceed the value determined by Table 6.2.4.</p> <p>The speed attained by a moving walk after startup shall not be intentionally varied, except as permitted by 6.2.4.1.2.</p>	<p>MOC-N (No.1417-2000) EXP. 2.(1) &(2)</p> <p>Rated speed is stipulated corresponding to inclination.</p> <p>[see Table C.8 in the Annex of this comparison]</p>

EN 115-1 (Europe)	A17.1/B44 (North America)	Japanese codes
	<p>Table 6.2.4 – Treadway speed</p> <p>max. treadway slope/max. speed m/s (ft/min)</p> <p>0° to 8°/0,9 (180)</p> <p>Above 8° to 12°/0,7 (140)</p> <p>6.2.4.1.2 Variation of the moving-walk speed after start-up shall be permitted provided the moving walk installation conforms to all of the following:</p> <p>(a) the acceleration and deceleration rates shall not exceed 0.3 m/s² (1.0 ft/sec²);</p> <p>(b) the rated speed is not exceeded;</p> <p>(c) the minimum speed shall be not less than 0,05 m/s (10 ft/min);</p> <p>(d) the speed shall not automatically vary during inspection operation;</p> <p>(e) passenger detection means shall be provided at both landings of the moving walk such that</p> <p>(1) detection of any approaching passenger shall cause the moving walk to accelerate to or maintain the full moving walk speed conforming to 6.2.4.1.2(a) through (d);</p> <p>(2) detection of any approaching passenger shall occur sufficiently in advance of boarding to cause the moving walk to attain full operating speed before a passenger walking at normal speed [1,35 m/s (270 ft/min)] reaches the combplate;</p> <p>(3) passenger detection means shall remain active at the egress landing to detect any passenger approaching against the direction of moving walk travel and shall cause the moving walk to accelerate to full rated speed and sound the alarm (see 6.2.6.3.1) at the approaching landing before the passenger reaches the combplate;</p> <p>(f) automatic deceleration shall not occur before a period of time has elapsed since the last passenger detection that is greater than three times the amount of time necessary to transfer a passenger between landings;</p> <p>(g) means shall be provided to detect failure of the passenger detection means and shall cause the moving walk to operate at full rated speed only.</p>	

EN 115-1 (Europe)	A17.1/B44 (North America)	Japanese codes
<p>The before mentioned requirements do not apply to moving walks with acceleration paths or moving walk systems with direct transition to moving walks travelling at different speeds.</p>	<p>—</p>	<p>MOC-N (No.1413-2000)</p> <p>2. The escalators of the special construction or the special use form to which the provisions described in the Art.129-3, item 3, paragraph 2 are not applied shall conform to the construction method specified in each paragraph come under the kind of the escalators described in following each paragraph.</p> <p>(3) The escalator of which speed varies in halfway of travel.</p> <p>It shall conform to the construction specified as follows.</p> <p>(h) It shall be that the speed of the step at the riding entrance and leaving exit is less than 50m/min.</p> <p>EXP. 2.(3) Maximum speed of moving walk which is accelerated at intermediate section is not stipulated, but speed at entrance and exit is stipulated up to 50 m /min.</p>
<p>5.4.1.3 Link between operational brake and step, pallet, or belt drive</p> <p>5.4.1.3.1 For the link between the operational brake and the step, pallet, or belt drive, preferably, non-friction driving elements should be used such as shafts, gear wheels, multiplex chains, and two or more single chains. Where friction elements are used such as trapezoidal belts (flat belts are not permitted), an auxiliary brake in accordance with 5.4.2.2 shall be used.</p>	<p>6.1.5/6.2.5 Driving machine, motor, and brake</p> <p>6.1.5.1/6.2.5.1 Connection between driving machine and main drive shaft. The driving machine shall be connected to the main drive shaft by toothed gearing, a mechanical coupling, or a chain.</p> <p>6.1.5.3/6.2.5.3 Brakes</p> <p>6.1.5.3.1/6.2.5.3.1 Escalator/moving walk driving-machine brake</p> <p>(e) Where means other than a continuous shaft, mechanical coupling, or toothed gearing is used to connect the motor to a gear reducer, the escalator/moving walk driving-machine brake shall be located on the gear reducer or main drive shaft.</p>	<p>—</p>
<p>(5.4.1.3.1.1)</p>	<p>6.2.3.13 Chain drives. Chain drives shall be of the type covered by ASME B29.1M and ANSI/SAE SP-68.</p> <p>When operating at the machinery rated load, the load imposed on such chains shall not exceed the horsepower rating established by these standards.</p> <p>The loading shall be considered to be uniform and the service to be 24 h per day.</p>	<p>—</p>

EN 115-1 (Europe)	A17.1/B44 (North America)	Japanese codes
(5.4.1.3.1.2)	6.2.3.14 V-belt drives. The load imposed on v-belt drives when operating at the machinery rated load shall not exceed the horsepower rating as established by ANSI/RMA IP-20. The loading shall be considered to be uniform and the service to be 24 hr per day.	—
<p>5.4.1.3.2 Safety factors of all driving elements shall be at least five for static calculations. In the case of trapezoidal belts, at least three belts shall be applied.</p> <p>This safety factor is determined as the ratio between the breaking force of the driving element and the static force to which the driving element is subjected when the escalator or inclined moving walk carries the rated load (person weight) according to 5.2.5 together with the tension force of the tensioning device.</p> <p>For horizontal moving walks the dynamic forces according to 5.4.2.1.3.3 respectively 5.4.2.1.3.4 together with the tension force of the tensioning device shall be used to determine the safety factor.</p>	<p>6.1.3.10/6.2.3.11 Design factors of safety. Factors of safety are based on either single driving-machine design or modular driving-machine design.</p> <p>The factors of safety shall be at least the following/as specified in 6.2.3.11.1 through 6.2.3.11.5.</p> <p>6.1.3.10.1/6.2.3.11.1 Trusses and all supporting structures including tracks, shall conform to the AISC specifications for design, fabrication, and erection of structural steel for buildings or the CSA standard CAN/CSA-S16.1, whichever is applicable (see Part 9) based on the maximum static load calculated per 6.1.3.9.1/6.2.3.10.1.</p> <p>6.1.3.10.2/6.2.3.11.2 For driving-machine parts based on not less than the loads calculated per 6.1.3.9.2/6.2.3.10.2:</p> <p>(a) where made of steel or bronze, the factor of safety shall be eight;</p> <p>(b) where made of cast iron or other materials, the factor of safety shall be 10.</p>	Refer to 5.4.3
<p>5.4.1.4 Hand winding device</p> <p>If a hand winding device is provided, it shall be easily accessible and safe to operate (see 7.2.1.3 and 7.4.1 g) for instructions).</p> <p>If the hand winding device is removable, an electric safety device [see Table 6 q)] in conformity with 5.12.1.2.2 shall be actuated when or before the hand winding device is put on the machine.</p> <p>Crank handles or perforate hand wheels are not permitted.</p>	—	—

EN 115-1 (Europe)	A17.1/B44 (North America)	Japanese codes
<p>5.4.1.5 Stopping the machine and checking its stopped position</p> <p>Stopping the escalator or moving walk by means of the electric safety devices according to 5.12.1.2 shall be effected as follows.</p> <p>The supply shall be interrupted by two independent contactors, the contacts of which shall be in series in the supply circuit. If, when the escalator or moving walk is stopped, one of the main contacts of one of the contactors has not opened, restarting shall be impossible.</p>	<p>6.1.6.10.4/6.2.6.9.3 Escalators/moving walks with driving-machine motors employing static control shall conform to the following:</p> <p>(a) two devices shall be provided to remove power from the driving-machine motor. At least one device shall be an electromechanical contactor;</p> <p>(1) the contactor shall be arranged to open each time the escalator/moving walk stops;</p> <p>(2) the contactor shall cause the removal of power from the driving-machine brake in accordance with 6.1.6.3.4/6.2.6.3.4;</p> <p>(b) an additional contactor shall be provided to also open the driving-machine brake circuit. This contactor is not required to have contacts in the driving-machine motor circuit’;</p> <p>(c) the electrical protective devices required by 6.1.6.3/6.2.6.3 shall control the solid-state device and both contactors;</p> <p>(d) after each stop of the escalator/moving walk, the escalator/moving walk shall not respond to a signal to start unless both contactors [see 6.1.6.10.4(a) and (b)/6.2.6.9.4 (a) and (b)] are in the de-energized position.</p>	<p>—</p>

EN 115-1 (Europe)	A17.1/B44 (North America)	Japanese codes
<p>5.4.2 Braking system</p> <p>5.4.2.1 Operational brake</p> <p>5.4.2.1.1 General</p> <p>5.4.2.1.1.1 Escalators and moving walks shall have a braking system by means of which they can be brought to rest with a uniform deceleration and maintained stationary (operational braking) (see also 5.12.1.2.4). There shall be no intentional delay in the application of the braking system.</p> <p>If the stopping distance exceeds the maximum values of 5.4.2.1.3.2 and 5.4.2.1.3.4 by more than 20 %, a restart shall be possible only after the failure lock has been reset [see Table 6 o)]. Before manual reset, the brake system has to be investigated and corrective action has to be taken, if necessary [see also 7.4.1 e)].</p> <p>A device shall be provided to monitor the lifting of the braking system after starting the escalator/moving walk [see also Table 6 l)].</p>	<p>6.1.5.3/6.2.5.3 Brakes</p> <p>6.1.5.3.1/6.2.5.3.1 Escalator/moving walk driving-machine brake</p> <p>(a) Each escalator/moving walk driving machine shall be provided with an electrically released and mechanically or magnetically applied brake. If the brake is magnetically applied, a ceramic permanent magnet shall be used. There shall be no intentional time delay designed into the application of the brake.</p> <p>(b) The escalator brake shall be provided with a data plate that is readily visible, located on the machine brake, and when necessary, a duplicate data plate with the certification mark shall be placed adjacent to the machine brake. The data plate shall indicate the following:</p> <p>(1) (a) for fixed torque brakes, the range of brake torque that complies with 6.1.5.3.1 and 6.1.6.3.6;</p> <p>(1) (b) for variable torque brakes, the minimum brake torque for a loaded escalator and the minimum stopping distance for the unloaded escalator which complies with 6.1.5.3.1 and 6.1.6.3.6;</p> <p>(2) the method of measuring the torque designated “BREAKAWAY” or “DYNAMIC” based on the method used when measuring the torque;</p> <p>(3) the location where the torque is to be measured, e.g. “MOTOR SHAFT”, “MACHINE INPUT SHAFT”, “MAIN DRIVE SHAFT”;</p> <p>(4) the type of brake as fixed or variable torque;</p> <p>(5) the maximum stopping distance with rated load in the down direction that corresponds to the minimum distance between the comb and the step when the step is positioned to activate any of the electrical protective devices required in 6.1.6.3.6, 6.1.6.3.9, 6.1.6.3.11, or 6.1.6.5;</p>	

EN 115-1 (Europe)	A17.1/B44 (North America)	Japanese codes
	<p>(d) the moving walk brake shall be provided with a data plate that is readily visible, located on, or adjacent to the machine brake and that indicates</p> <p>(1) the range of brake torques in N·m (ft·lb) that complies with 6.2.5.3.1;</p> <p>(2) the method of measuring the torque, designated "BREAKAWAY", or "DYNAMIC" based on the method used when measuring the torque;</p> <p>(3) the location where the torque is to be measured, e.g. "MOTOR SHAFT", "MACHINE INPUT SHAFT", "MAIN DRIVE SHAFT";</p> <p>(4) the minimum stopping distance with no load;</p> <p>(5) the maximum stopping distance with rated load in the down direction that corresponds to the minimum distance between the comb and the pallet when the pallet is positioned to activate any of the electrical protective devices required in 6.2.6.3.9 or 6.2.6.5;</p> <p>(e) where means other than a continuous shaft, mechanical coupling, or toothed gearing is used to connect the motor to a gear reducer, the escalator/moving walk driving-machine brake shall be located on the gear reducer or main drive shaft.</p>	

EN 115-1 (Europe)	A17.1/B44 (North America)	Japanese codes
<p>5.4.2.1.1.2 The braking system shall operate automatically:</p> <p>a) in the event of loss of the voltage supply, and</p> <p>b) in the event of loss of the voltage supply to the control circuits.</p>	<p>6.1.5.3.1/6.2.5.3.1 escalator/moving walk driving-machine brake</p> <p>(b) The brake shall be applied automatically if the electrical power supply is interrupted. The brake shall be capable of stopping the down-running escalator/down- or horizontal-running moving walk with any load up to the brake rated load [see 6.1.3.9.3/6.2.3.10.3(a) (2) or (b) (2)]. The brake shall hold the stopped moving walk with any load up to the brake rated load [see 6.1.3.9.3/6.2.3.10.3(a) (1) or (b) (1)].</p>	<p>MOC-N (No. 1424-2000)</p> <p>1(2) (b) Detected device shall be provided in the event of loss of the voltage supply.</p> <p>BSLJ-EO; Article 129-12</p> <p>4. Escalators shall be provided with the emergency stopping devices and devices to stop the ascending or the descending steps at the entrances and exits of the escalators.</p> <p>5. The constructions of the preceding emergency stopping devices shall be the construction methods specified by the minister of land, infrastructure, and transport so as to have performance which operate automatically and enable to stop the steps safely with the deceleration in operating direction of not more than 1,25 m/sec² when power supply fail, break down of driving devices, person or articles are caught, and in case of that persons are liable to be injured or articles are damaged or the construction methods approved by the minister of land, infrastructure, and transport.</p>
<p>5.4.2.1.1.3 Operational braking shall be effected by an electro-mechanical brake or by other means.</p> <p>Where no electro-mechanical operational brake is used, an auxiliary brake in accordance with 5.4.2.2 shall be provided.</p>	<p>6.1.5.3.1/6.2.5.3.1 Escalator/moving walk driving-machine brake</p> <p>(a) Each escalator/moving walk driving machine shall be provided with an electrically released and mechanically or magnetically applied brake. If the brake is magnetically applied, a ceramic permanent magnet shall be used. There shall be no intentional time delay designed into the application of the brake.</p>	<p>—</p>
<p>5.4.2.1.1.4 Brakes that can be released by hand shall require continuous application of manual pressure to keep them open.</p>	<p>—</p>	<p>—</p>

EN 115-1 (Europe)	A17.1/B44 (North America)	Japanese codes						
<p>5.4.2.1.2 Electro-mechanical brake</p> <p>The normal lifting of the electro-mechanical brake shall be by a continuous flow of electric current. The braking operation shall be effective immediately after the electric brake circuit is opened.</p> <p>The brake force shall be generated by guided compression spring(s). Electrically generated self-excitation of the brake releasing device shall be impossible.</p> <p>The interruption of the electricity supply shall be effected by at least two independent electrical devices. They can be those which break the supply to the machine. If after the stop of the escalator or moving walk one of these electrical devices has not opened, restarting shall be prevented (see also 5.4.1.5).</p>	<p>6.1.5.3.1/6.2.5.3.1 Escalator/moving walk driving-machine brake</p> <p>(a) Each escalator/moving walk driving machine shall be provided with an electrically released and mechanically or magnetically applied brake. If the brake is magnetically applied, a ceramic permanent magnet shall be used. There shall be no intentional time delay designed into the application of the brake.</p> <p>(b) The brake shall be applied automatically if the electrical power supply is interrupted. The brake shall be capable of stopping the down-running escalator/down- or horizontal-running moving walk with any load up to the brake rated load [see 6.1.3.9.3/6.2.3.10.3(a) (2) or (b) (2)]. The brake shall hold the stopped moving walk with any load up to the brake rated load [see 6.1.3.9.3/6.2.3.10.3(a) (1) or (b) (1)].</p>	<p>BSLJ-EO; Art. 129-12, 5, EXP.</p> <p>The brake shall be applied automatically if the electrical power supply is interrupted.</p>						
<p>5.4.2.1.3 Brake load and stopping distances for operational brake</p> <p>5.4.2.1.3.1 Determination of brake load for escalators</p> <p>Table 2 shall be applied for the determination of the brake load for escalators.</p> <p><i>Table 2 reads:</i></p> <p>Per step and at a nominal width z_1 of</p> <table border="0" data-bbox="97 1422 528 1518"> <tr> <td>up to 0,6 m</td> <td>60 kg</td> </tr> <tr> <td>more than 0,6 m up to 0,8 m</td> <td>90 kg</td> </tr> <tr> <td>more than 0,8 m up to 1,1 m</td> <td>120 kg</td> </tr> </table> <p>shall be applied.</p> <p>The number of steps to be considered is determined by “rise, h_{13}, divided by maximal visible height of the step riser” (see x_1 in Figure 5).</p>	up to 0,6 m	60 kg	more than 0,6 m up to 0,8 m	90 kg	more than 0,8 m up to 1,1 m	120 kg	<p>6.1.3.9.3 Brake</p> <p>(a) For the purpose of brake calculations, the rated load for all single driving machines shall be considered to be not less than the following.</p> <p>(1) With escalator stopped:</p> <p><i>(SI units)</i></p> <p>Brake rated load (kg) = $D_5 (W + 203) B_1 / 1\ 000$</p> <p><i>(Imperial units)</i></p> <p>Brake rated load (lb) = $D_6 (W + 8) B_1 / 12$</p> <p>(2) With escalator running:</p> <p><i>(SI units)</i></p> <p>Brake rated load (kg) = $D_3 (W + 203) B_1 / 1\ 000$</p> <p><i>(Imperial units)</i></p>	<p>—</p>
up to 0,6 m	60 kg							
more than 0,6 m up to 0,8 m	90 kg							
more than 0,8 m up to 1,1 m	120 kg							

EN 115-1 (Europe)	A17.1/B44 (North America)	Japanese codes																
<p>For the purpose of a test, the total brake load is permitted to be distributed over two-thirds of the number of steps, thus, obtained.</p>	<p>Brake rated load (lb) = $D_4 (W + 8) B_1/12$</p> <p>(b) The rated load per module for two or more modular driving machines shall be considered to be not less than the following.</p> <p>(1) With escalator stopped: (SI units) Brake rated load (kg) = $D_5 (W + 203) B_2/1\ 000$ (Imperial units) Brake rated load (lb) = $D_6 (W + 8) B_2/12$</p> <p>(2) With escalator running: (SI units) Brake rated load (kg) = $D_3 (W + 203) B_2/1\ 000$ (Imperial units) Brake rated load (lb) = $D_4 (W + 8) B_2/12$</p> <p>where: $B_1 = \cot \theta \times \text{total rise, m (ft)}$; $B_2 = \cot \theta \times \text{rise per module, m (ft)}$; $D_3 = \text{loading factor} = 210 \text{ kg/m}^2$; $D_4 = \text{loading factor} = 42.0 \text{ lb/ft}^2$; $D_5 = \text{loading factor} = 360 \text{ kg/m}^2$; $D_6 = \text{loading factor} = 73.7 \text{ lb/ft}^2$; $W = \text{width of the escalator, mm (in.)}$ (see 6.1.3.2); $\theta = \text{the angle of inclination, degrees}$ (see 6.1.3.1).</p>																	
<p>Explanation: Escalator brake loads EN 115-1/ A17.1/B44 in kg</p> <table border="1" data-bbox="304 1552 954 1832"> <thead> <tr> <th>Step width</th> <th>600 mm</th> <th>800 mm</th> <th>1 000 mm</th> </tr> </thead> <tbody> <tr> <td>EN 115-1</td> <td>295 × H</td> <td>443 × H</td> <td>591 × H</td> </tr> <tr> <td>A17.1/B44 Static Load</td> <td>376 × H</td> <td>469 × H</td> <td>563 × H</td> </tr> <tr> <td>A17.1/B44 Dyn. Load</td> <td>292 × H</td> <td>365 × H</td> <td>438 × H</td> </tr> </tbody> </table> <p>NOTE: H means rise in m</p>		Step width	600 mm	800 mm	1 000 mm	EN 115-1	295 × H	443 × H	591 × H	A17.1/B44 Static Load	376 × H	469 × H	563 × H	A17.1/B44 Dyn. Load	292 × H	365 × H	438 × H	
Step width	600 mm	800 mm	1 000 mm															
EN 115-1	295 × H	443 × H	591 × H															
A17.1/B44 Static Load	376 × H	469 × H	563 × H															
A17.1/B44 Dyn. Load	292 × H	365 × H	438 × H															

EN 115-1 (Europe)	A17.1/B44 (North America)	Japanese codes
<p>5.4.2.1.3.2 Stopping distances for the escalator</p> <p>The stopping distances for unloaded and downward moving loaded escalators (see 5.4.2.1.3.1) shall be as given in Table 3.</p> <p><i>Table 3 reads:</i></p> <p><u>Nominal speed, v, stopping distance between</u></p> <p>0,50 m/s min. 0,20 m and max. 1,00 m</p> <p>0,65 m/s min. 0,30 m and max. 1,30 m</p> <p>0,75 m/s min. 0,40 m and max. 1,50 m</p> <p>For intermediate speeds the stopping distances shall be interpolated.</p> <p>The stopping distances shall be measured from the time the electric stopping device is actuated.</p> <p>The deceleration, measured on a downward moving escalator in the direction of travel shall not exceed 1 m/s² during the operation of the braking system. The raw deceleration signal shall be band-limited using a 4,0 Hz two-pole Butterworth filter.</p> <p>NOTE It is recommended to achieve the shortest possible stopping distance within the given deceleration limit.</p>	<p>6.1.5.3.1 Escalator driving-machine brake</p> <p>(c) Driving-machine brakes shall stop the down-running escalator steps at an average rate not greater than 0.91 m/s² (3 ft/s²) as measured over the total retardation time. No peak horizontal retardation value exceeding 0,91 m/s² (3 ft/s²) shall have a time duration greater than 0,125 s (see Nonmandatory Appendix I, Fig. I-11). See also 6.1.6.3.6.</p>	<p>JIS A 4302-2006; 5.4.1 Inspection to be carried out in the machinery room</p> <p>(c) The brake of driving machine shall operate properly and its braking force shall be capable of stopping the ascending steps without load within 0,1 to 0,6 m inclusive.</p> <p>BSLJ-EO; Article 129-12</p> <p>5. The constructions of the preceding emergency stopping devices shall be the construction methods specified by the minister of land, infrastructure, and transport so as to have performance which operate automatically and enable to stop the steps safely with the deceleration in operating direction of not more than 1,25 m/sec² when power supply fail, break down of driving devices, person or articles are caught, and in case of that persons are liable to be injured or articles are damaged or the construction methods approved by the minister of land, infrastructure, and transport.</p> <p>BSLJ-EO; Article 129-12 5</p> <p>The constructions of the preceding emergency stopping devices shall be the construction methods specified by the minister of land, infrastructure, and transport so as to have performance which operate automatically and enable to stop the steps safely with the deceleration in operating direction of not more than 1,25 m/sec² when power supply fail, break down of driving devices, person or articles are caught, and in case of that persons are liable to be injured or articles are damaged or the construction methods approved by the minister of land, infrastructure, and transport.</p>

EN 115-1 (Europe)	A17.1/B44 (North America)	Japanese codes												
		<p>MOC-N (No.1424-2000)</p> <p>Based on the stipulation of the Art.129-12, item 5 of the Building Standard Law Enforcement Order (1950-Cabinet Order No.338), construction method of breaking devices for the escalator is specified as follows.</p> <p>1. The construction method of the braking devices for the escalator shall conform to each paragraph described below.</p> <p>(3) When any situations described in preceding (a) to (e) are detected, the stopping distance of the escalators with no load condition shall be not less than the value obtained by the following formula and not exceeding 0,6 m for the escalator with inclination of 15° and more or the escalator with the difference in level between each adjacent steps is exceeding 4 mm.</p> $S = v^2/9\ 000$ <p>where:</p> <p>S is the stopping distance of the step (unit m)</p> <p>v is the rated speed of the escalator (unit m/min.)</p>												
<p>5.4.2.1.3.3 Determination of the brake load for moving walks</p> <p>Table 4 shall be applied for the determination of the brake load for moving walks.</p> <p><i>Table 4 reads:</i></p> <p>Per 0,4 m length and at a nominal width z_1 of the pallets or the belt of the following:</p> <table border="0"> <tr> <td>up to 0,60 m</td> <td>50</td> </tr> <tr> <td>kg</td> <td></td> </tr> <tr> <td>more than 0,60 m up to 0,80 m</td> <td>75 kg</td> </tr> <tr> <td>more than 0,80 m up to 1,10 m</td> <td>100 kg</td> </tr> <tr> <td>more than 1,10 m up to 1,40 m</td> <td>125 kg</td> </tr> <tr> <td>more than 1,40 m up to</td> <td></td> </tr> </table>	up to 0,60 m	50	kg		more than 0,60 m up to 0,80 m	75 kg	more than 0,80 m up to 1,10 m	100 kg	more than 1,10 m up to 1,40 m	125 kg	more than 1,40 m up to		<p>6.2.3.10.3 Brake</p> <p>(a) For the purpose of brake calculations, the rated load for all single driving machines shall be considered to be not less than the following.</p> <p>(1) With moving walk stopped:</p> <p><i>(SI units)</i></p> <p>Brake rated load (kg) = $D_7 (W) C_1/1\ 000$</p> <p><i>(Imperial units)</i></p> <p>Brake rated load (lb) = $D_8 (W) C_1/12$</p> <p>(2) With moving walk running:</p> <p><i>(SI units)</i></p> <p>Brake rated load (kg) = $D_9 (W) C_1/1\ 000$</p> <p><i>(Imperial units)</i></p>	<p>—</p>
up to 0,60 m	50													
kg														
more than 0,60 m up to 0,80 m	75 kg													
more than 0,80 m up to 1,10 m	100 kg													
more than 1,10 m up to 1,40 m	125 kg													
more than 1,40 m up to														

EN 115-1 (Europe)	A17.1/B44 (North America)	Japanese codes
<p>1,65 m 150 kg.</p> <p>To determine the brake load for moving walks, which in their length overcome several inclinations (differences in level), only the downward moving sections shall be considered.</p>	<p>Brake rated load (lb) = $D_{10} (W) C_1/12$</p> <p>(b) The rated load per module for two or more modular driving machines shall be considered to be not less than the following.</p> <p>(1) With moving walk stopped: (SI units)</p> <p>Brake rated load (kg) = $D_7 (W) C_2/1\ 000$</p> <p>(Imperial units)</p> <p>Brake rated load (lb) = $D_8 (W) C_2/12$</p> <p>(2) With moving walk running: (SI units)</p> <p>Brake rated load (kg) = $D_9 (W) C_2/1\ 000$</p> <p>(Imperial units)</p> <p>Brake rated load (lb) = $D_{10} (W) C_2/12$</p> <p>where:</p> <p>C_1 = length of exposed treadway, m (ft);</p> <p>C_2 = length of exposed treadway per module, m (ft);</p> <p>D_7 = loading factor = 490 kg/m²;</p> <p>D_8 = loading factor = 100 lb/ft²;</p> <p>D_9 = loading factor = 370 kg/m²;</p> <p>D_{10} = loading factor = 75,0 lb/ft²;</p> <p>W = width of the moving walk, mm (in.) (see 6.2.3.2.1 and 6.2.3.7).</p>	
—	—	—

EN 115-1 (Europe)	A17.1/B44 (North America)	Japanese codes
<p>5.4.2.1.3.4 Stopping distances for moving walks</p> <p>The stopping distances for unloaded and horizontally or downward moving loaded moving walks (see 5.4.2.1.3..3) shall be as given in Table 5.</p> <p><i>Table 5 reads:</i></p> <p><u>Nominal speed, v. Stopping distance between</u></p> <p>0,50 m/s min. 0,20 m and max. 1,00 m</p> <p>0,65 m/s min. 0,30 m and max. 1,30 m</p> <p>0,75 m/s min. 0,40 m and max. 1,50 m</p> <p>0,90 m/s min. 0,55 m and max. 1,50 m</p> <p>For intermediate speeds, the stopping distances shall be interpolated.</p> <p>The stopping distances shall be measured from the time the electric stopping device is actuated.</p>	<p>6.2.5.3.1 Moving walk driving-machine brakes</p> <p>(c) Driving-machine brakes shall stop the down- or horizontally-running treadway at an average rate not greater than 0,91 m/s² (3 ft/s²) as measured over the total retardation time. No peak horizontal retardation value exceeding 0,91 m/s² (3 ft/s²) shall have a time duration greater than 0,125 s (see Nonmandatory Appendix I, Fig. I-11).</p>	<p>JIS A 4302-1992; 4.4.1 Inspection to be carried out in the machinery room</p> <p>(3) The brake of driving machine shall operate properly and its braking force shall be capable of stopping the ascending steps without load within 0,1 to 0,6 m inclusive.</p> <p>BSLJ-EO; Article 129-12</p> <p>5. The constructions of the preceding emergency stopping devices shall be the construction methods specified by the minister of land, infrastructure, and transport so as to have performance which operate automatically and enable to stop the steps safely with the deceleration in operating direction of not more than 1,25 m/sec² when power supply fail, break down of driving devices, person or articles are caught, and in case of that persons are liable to be injured or articles are damaged or the construction methods approved by</p>

EN 115-1 (Europe)	A17.1/B44 (North America)	Japanese codes
<p>The deceleration measured on a downward moving escalator in the direction of travel shall not exceed 1 m/s² during the operation of the braking system. The raw deceleration signal shall be band-limited using a 4,0 Hz two-pole Butterworth filter.</p> <p>NOTE It is recommended to achieve the shortest possible stopping distance within the given deceleration limit. For moving walks, a brake test under no load will be sufficient.</p> <p>For loaded passenger conveyors, the manufacturer shall prove the stopping distances by calculation [see 6.2.c)].</p>		<p>the minister of land, infrastructure, and transport.</p> <p>MOC-N (No.1424-2000)</p> <p>Based on the stipulation of the Art.129-12, item 5 of the Building Standard Law Enforcement Order (1950-Cabinet Order No.338), construction method of breaking devices for the escalator is specified as follows.</p> <p>1. The construction method of the braking devices for the escalator shall conform to each paragraph described in below.</p> <p>(3) When any situations described in preceding (a) to (e) are detected, the stopping distance of the escalators with no load condition shall be not less than the value obtained by the following formula and not exceeding 0,6 m for the escalator with inclination of 15° and more or the escalator with the difference in level between each adjacent steps is exceeding 4 mm.</p> <p>$S = v^2/9\ 000$</p> <p>where:</p> <p>S is the stopping distance of the step unit m);</p> <p>v is the rated speed of the escalator (unit m/min).</p>

EN 115-1 (Europe)	A17.1/B44 (North America)	Japanese codes
<p>5.4.2.2 Auxiliary brake</p> <p>5.4.2.2.1 Escalators and moving walks shall be equipped with auxiliary brake(s) if</p> <p>a) the connection between the operational brake (see 5.4.2.1) and the driving sprockets of the steps/pallets or the drum of the belt is not accomplished by shafts, gear wheels, multiplex chains, or more than one single chain, ob) the operational brake is not an electro-mechanical brake according to 5.4.2.1.2;</p> <p>b) the operational brake is not an electro-mechanical brake according to 5.4.2.1.2;</p> <p>c) the rise, h_{13}, exceeds 6 m (see also H.2).</p> <p>The connection between the auxiliary brake and the driving sprockets of the steps/pallets or the drum of the belt shall be accomplished by shafts, gear wheels, multiplex chains, or more than one single chain. It is not permissible for the connection to comprise friction drives, i.e. clutches.</p>	<p>6.1.5.3.2 Main drive shaft brake. If the escalator driving-machine brake is separated from the main drive shaft by a chain used to connect the driving machine to the main drive shaft, a mechanically or magnetically applied brake capable of stopping a down-running escalator with brake rated load (see 6.1.3.9.3) shall be provided on the main drive shaft. If the brake is magnetically applied, a ceramic permanent magnet shall be used.</p> <p>6.2.5.3.2 Main drive shaft brake. If the moving walk driving-machine brake is connected to the main drive shaft by a chain and the moving walk with the drive chain disconnected is capable of running under gravity with any load up to and including rated load (see 6.2.3.10.2), a mechanically or magnetically applied brake capable of stopping a down-running moving walk with brake rated load (see 6.2.3.10.3) shall be provided on the main drive shaft or specially attached braking surface attached directly to the treadway. If the brake is magnetically applied, a ceramic permanent magnet shall be used.</p>	<p>MOC-N (No.1424-2000)</p> <p>EXP.2. The escalator shall be provided with the following safety devices and shall be stopped depend on detecting the operation of these safety devices.</p> <p>(a) The step chain safety device which stop the escalator rapidly and surely when the step chain stretches extremely or breaks.</p> <p>Although not stipulated in this regulation, for the escalator which uses the chain (called as the main drive chain) to transmit the driving force from the driving machine to the step chain sprocket, it is required to furnish the escalator with the mechanical brake to prevent the step from descending and the safety switch to stop the driving motor when the main drive chain brakes.</p> <p>In this case, it needs rapidly to stop the stopping distance of the escalators allowed to over the value obtained by the formula described in item (3).</p>
<p>5.4.2.2.2 The auxiliary braking system shall be dimensioned in such a way that escalators and moving walks travelling with brake load downward are brought to rest by effective retardation and maintained stationary. The deceleration of 1 m/s^2 shall not be exceeded.</p>		—
<p>Upon operation of the auxiliary brake, it is not necessary to keep the stopping distances defined for the operational brake (see 5.4.2.1.3).</p>		—
<p>5.4.2.2.3 Auxiliary brakes shall be of the mechanical (friction) type.</p>	See above	—
<p>5.4.2.2.4 The auxiliary brake shall become effective in either of the following conditions:</p> <p>a) before the speed exceeds a value of 1,4 times the nominal speed;</p> <p>b) by the time the steps and pallets or the belt change from the present direction of motion.</p> <p>Its operation shall positively open the control circuit.</p>	<p>6.1.6.3.4 Drive-chain device. When the driving machine is connected to the main drive shaft by a chain, a device shall be provided that will cause the application of the brake on the main drive shaft and will also cause the electric power to be removed from the drivingmachine motor and brake if the drive chain between the machine and the main drive shaft becomes disengaged from the sprockets. The device shall be of the manual reset type.</p>	—

EN 115-1 (Europe)	A17.1/B44 (North America)	Japanese codes
<p>5.4.2.2.5 Auxiliary brakes are permitted to operate together with the operational brake when in case of power failure or of an interruption of a safety circuit, the stopping distances, according to 5.4.2.1.3.2 and 5.4.2.1.3.4, are kept. Otherwise, a simultaneous operation of the auxiliary and the operational braking system is only permitted under the conditions of 5.4.2.2.4.</p>	<p><i>Commentary: (The Main Drive Shaft Brake¹³) is only applied when the Main Drive-Chain breaks, and is only required when a chain is used to connect the main drive shaft to the machine).</i></p>	<p>—</p>
<p>5.4.2.3 Protection against risks of excessive speed and unintentional reversal of the direction of travel.</p> <p>5.4.2.3.1 Escalators and moving walks shall be equipped in such a way that they stop automatically before the speed exceeds a value of 1,2 times the nominal speed [see Table 6 c)]. Where speed control devices are used for this purpose, they shall have switched off the escalator or moving walk before the speed exceeds a value of 1,2 times the nominal speed.</p> <p>It is permissible to disregard this requirement if the design prevents excessive speed.</p>	<p>6.1.6.3.2/6.2.6.3.2 Escalator/moving walk speed monitoring device. An escalator/moving walk speed-monitoring device shall be provided.</p> <p>(a) The operation of the device shall cause the electric power to be removed from the driving machine motor and brake should the speed exceed the rated speed by more than 20 %.</p> <p>(b) The device shall be of the manual-reset type.</p>	<p>—</p>
<p>5.4.2.3.2 Escalators and inclined ($\alpha \geq 6^\circ$) moving walks shall be equipped in such a way that they stop automatically by the time the steps and pallets or the belt change from the preset direction of travel [see Table 6 c)].</p>	<p>6.1.6.3.8/6.2.6.3.7 Reversal stop device. Means shall be provided to cause the opening of the power circuit to the driving-machine motor and brake in case of accidental reversal of travel while the escalator/moving walk is operating in the ascending direction. The device shall be of the manually reset type.</p>	<p>—</p>
<p>5.4.3 Steps and pallets drive</p> <p>5.4.3.1 The steps of escalators shall be driven by at least two steel link chains of which at least one shall be located on each side of the step.</p> <p>The pallets of moving walks are permitted to be driven by only one chain if the parallel movement of the pallets in the usable area is ensured by other mechanical measures.</p>	<p>6.1.3.11/6.2.3.12 Chains</p> <p>The use of chains with cast iron links shall not be permitted.</p>	<p>MOC-N (No. 1418-2000), 2(4) EXP.2</p> <p>The steps of escalators shall be driven by at least two chains on each side of the step.</p>
<p>5.4.3.2 The step chain design shall be of nominally infinite fatigue life.</p>	<p>—</p>	<p>—</p>

EN 115-1 (Europe)	A17.1/B44 (North America)	Japanese codes
<p>The safety factor against breaking of each chain shall be at least five (see 5.4.1.3.2) with respect to structural steel according to EN 10025-1 in combination with EN 10025-2, EN 10025-3, EN 10025-4, EN 10025-5, and EN 10025-6 and with respect to quenched and tempered steel according to EN 10083-1 in combination with EN 10083-2 and EN 10083-3. The step chain shall be subject to a tensile test.</p>	<p>6.1.3.10.3/6.2.3.11.3 For power transmission members, the factor of safety shall be 10 based on not less than the loads calculated per 6.1.3.9.2/6.2.3.10.2.</p>	<p>MOC-N (No.1418-2000) 2(3),(4)</p> <p>2. The escalator strength verification method shall conform to the following item.</p> <p>(3) The safety factor of the chain and other similar equipment and hitch part of the chain or belt for the escalators shall be not less than the value described in the following table.</p> <p>[see Table C.4 in the Annex of this comparison]</p> <p>(4) In the Art.129-12, item 2 of the Building Standard Law Enforcement Order, the critical safety factor stipulated in the Art.129-4, item 2, paragraph 4 applied mutatis mutandis (restricted to that the step is not supported by the other equipment not liable to abrasion or fatigued destruction) shall be not less than the value described in the following table.</p> <p>[see Table C.5 in the Annex of this comparison]</p>
<p>When more than one chain is used, it is assumed that the load is equally distributed over the chains.</p>	<p>—</p>	<p>—</p>
<p>5.4.3.3 The chains shall be tensioned continuously. The escalator/moving walk shall be stopped automatically before the tensioning device moves in excess of ± 20 mm [see Table 6 e) and f)]. Springs working in tension are not permitted for the tensioning device. When weights are used for tensioning they shall be safely retained, should their suspension break.</p>	<p>6.1.6.3.3 Broken step-chain device</p> <p>(a) A broken step-chain device shall be provided which shall cause the electric power to be removed from the driving-machine motor and brake</p> <p>...</p> <p>(2) Where no automatic chain tension device is provided, if excessive sag occurs in either step chain.</p>	<p>MOC-N (No. 1424-2000), 1(2)(a)</p> <p>Detected device shall be provided in the event of abnormal elongation of step chain.</p> <p>JIS A 4302-2006 5.4.2 (a)</p>

EN 115-1 (Europe)	A17.1/B44 (North America)	Japanese codes
<p>5.4.4 Belt drive</p> <p>5.4.4.1 The factor of safety of the belt including splicing shall be at least five (see 5.4.1.3.2) for the dynamic forces according to 5.4.2.1.3.3, respectively, 5.4.2.1.3.4. The calculation shall be carried out for the worst case.</p> <p>The belt shall be driven by drums and be tensioned continuously and automatically. Springs working in tension are not permitted for the tensioning device. When weights are used for tensioning, they shall be safely retained should their suspension break.</p>	<p>6.2.3.11.5 For belts, factor of safety shall be five based on not less than the loads designated in 6.2.3.10.2.</p>	<p>MOC-N (No.1418-2000) 2(3),(4)</p> <p>2. The escalator strength verification method shall conform to the following item.</p> <p>(3) The safety factor of the chain and other similar equipment and hitch part of the chain or belt for the escalators shall be not less than the value described in the following table.</p> <p>[see Table C.4 in the Annex of this comparison]</p> <p>(4) In the Art.129-12, item 2 of the Building Standard Law Enforcement Order, the critical safety factor stipulated in the Art.129-4, item 2, paragraph 4 applied mutatis mutandis (restricted to that the step is not supported by the other equipment not liable to abrasion or fatigued destruction) shall be not less than the value described in the following table.</p> <p>[see Table C.5 in the Annex of this comparison]</p>
<p>5.4.4.2 The belt shall be driven by drums and be tensioned continuously and automatically. Springs working in tension are not permitted for the tensioning device. When weights are used for tensioning, they shall be safely retained should their suspension break.</p>	<p>—</p>	<p>—</p>
<p>5.5 Balustrade</p> <p>5.5.1 General</p> <p>Balustrades shall be installed on each side of the escalator or moving walk.</p>	<p>6.1.3.3/6.2.3.3 Balustrades. Balustrades shall be installed on each side of the escalator/moving walk (see Nonmandatory Appendix I, Fig. I-3/7).</p>	<p>BSLJ - EO; Article 129 - 12</p> <p>1.(3) Escalators shall be provided with handrails at each side of steps (the portion going up and down on which the persons step). The upper surface of the handrails shall move in the same direction and at the same speed as the steps.</p>
<p>5.5.2 Dimensions of balustrade</p> <p>5.5.2.1 In the inclined section the vertical height, h_1, from step nose or pallet surface or belt surface to top of the handrail shall be not less than 0,90 m and not exceed 1,10 m (see Figures 2 and 3).</p>	<p>6.1.3.4.5 Vertical height. The vertical height from step nose to top of handrail shall be not less than 900 mm (35 in.) nor more than 1 000 mm (39 in.) (see 6.1.3.6.6 for floor opening protection adjacent to escalator wellways).</p> <p>6.2.3.2.2 The height of the balustrade shall be not less than 900 mm (35 in.) nor more than 1 000 mm (39 in.) from the treadway to the top of handrail measured perpendicular to the treadway surface.</p>	<p>—</p>

EN 115-1 (Europe)	A17.1/B44 (North America)	Japanese codes
<p>5.5.2.2 The balustrades shall have no parts on which a person would normally stand.</p> <p>Appropriate measures shall be taken to discourage people from climbing on the outsides of the balustrade if there is a danger of people falling from them.</p> <p>To ensure this, escalators and moving walks devices (see 1 in Figure 4) shall be provided on the lower outer decking at a point $(1\ 000 \pm 50)$ mm above the floor level (see h_9 in Figure 4) where the bottom of the device intersects with the balustrade decking and shall extend to a length l_5 of at least 1 000 mm parallel with the balustrade decking where no stepping is possible. The device shall extend to at least a height in line with the top of the handrail not conflicting with the requirements of b_{10} and b_{12}.</p> <p>Where escalators or moving walks</p>	<p>6.1.3.3.12 Antislid device. On high deck balustrades, anti-slide devices shall be provided on decks or combination of decks when the outer edge of the deck is greater than 200 mm (8 in.) from the centre line of the handrail or on adjacent escalators when the unobstructed distance between the edge of the facing handrail is greater than 300 mm (12 in.).</p> <p>These devices shall consist of raised objects fastened to the decks no closer than 100 mm (4 in.) to the handrail, nor greater than 300 mm. (12 in.) from the handrail. They shall be spaced not greater than 2 000 mm (78 in.) apart as measured on a line parallel to the direction of travel and not greater than 300 mm (12 in.) as measured on a horizontal line perpendicular to the direction of travel. The height shall be no less than 50 mm (2 in.). There shall be no sharp corners or edges (see Nonmandatory Appendix I, Fig. I-6).</p>	<p>JEAS A 406 Standard for surroundings and supervision of escalators</p> <p>3.1.6 If there is any possibility that children can easily approach the side of the escalator and go upstairs on the deck board for fun, a partition plate, etc. shall be furnished halfway on the deck board to prevent them for safety measures. Furthermore, it is recommended that partition plates to prevent climbing up be furnished at two locations on one side. (Refer to Figure 3.)</p>

EN 115-1 (Europe)	A17.1/B44 (North America)	Japanese codes
<p>are located adjacent to walls, devices (see 2 in Figure 4) to restrict access to the balustrade decking shall be provided at the top and bottom ends of these walls when the lower outer decking width, b_{13}, exceeds 125 mm. On adjacent parallel arrangements, this protection shall be provided when the combined balustrade decking width, b_{14}, exceeds 125 mm. The device shall extend to the height, h_{10}.</p> <p>All exposed fastener heads for the devices shall be of the vandal resistant type.</p> <p>Where handrail level balustrade decking are provided between escalators/inclined moving walks and adjacent walls, anti-slide devices (see 3 in Figure 4) shall be provided on the balustrade decking when the distance, b_{15}, between the structure of the building (wall) and the centreline of the handrail is greater than 300 mm. These devices shall consist of objects fastened to the balustrade decking no closer than 100 mm to the handrail (see b_{17}) and spaced no greater than 1 800 mm apart. The height, h_{11}, shall be not less than 20 mm. The devices shall have no sharp corners or edges.</p> <p>The above mentioned also applies to adjacent escalators/inclined</p>	<p>6.1.3.3.13/ Deck barricades.</p> <p>(a) A barricade to restrict access to the outer deck on low deck exterior balustrades shall be provided at the top and bottom ends of each escalator where the outer deck width exceeds 125 mm (5 in.). On parallel abutting unit, this protection shall be provided where the combined outer deck width exceeds 125 mm (5 in.). The barricade shall extend to a height which is nominally 100 mm (40 in.) below the top of the handrail.</p> <p>(b) When an escalator is not located at the edge of a floor surface, the barricade shall be installed on the outer deck at a point 1 000 mm (40 in.) above the floor where the bottom of the barricade intersects the outer deck.</p> <p>(c) On parallel adjacent escalators, where the common low deck between adjacent interior panels exceeds 400 mm (16 in.), deck barricades should be spaced evenly up the incline the treadway at no greater than 4,6 m (15 ft) measured on a line parallel to the direction of travel.</p> <p>(d) Barricades may be made of glass or plastic shall conform to the requirements of 6.1.3.3.3. All exposed barricade attachment fastener heads shall be of the tamper-resistant type.</p>	

EN 115-1 (Europe)	A17.1/B44 (North America)	Japanese codes
<p>moving walks when the distance, b_{16}, between the centrelines of the handrails is greater than 400 mm.</p>	<p>6.2.3.3.8 Deck barricades.</p> <p>(a) A barricade to restrict access to the outer deck on low deck exterior balustrades shall be provided on each moving walk when the exterior deck is greater than 915 mm (36 in.) above the floor in any part of its travel and the exterior deck width exceeds 125 mm (5 in.). On parallel abutting unit, this protection shall be provided where the combined outer deck width exceeds 125 mm (5 in.). The barricade shall extend to a height that is nominally 100 mm (40 in.) below the top of the handrail.</p> <p>(b) The barricades shall be located wherever the exterior deck exceeds 915 mm (36 in.) height above the floor.</p> <p>(c) On parallel adjacent moving walks where the common low deck between adjacent interior panels exceeds 400 mm (16 in.), deck barricades should be spaced evenly along the treadway at not greater than 4,6 m (15 ft) measured on a line parallel to the direction of travel.</p> <p>(d) Barricades may be made of glass or plastic shall conform to the requirements of 6.2.3.3.3.</p> <p>All exposed barricade attachment fastener heads shall be of the tamper-resistant type.</p>	
<p>5.5.2.3 Balustrades shall be designed to resist the simultaneous application of a static lateral force of 600 N and a vertical force of 730 N both equally distributed over a length of 1 m and acting on the top of the handrail guiding system in the same place.</p>	<p>6.1.3.3.2/6.2.3.3.2 Strength. Balustrades shall be designed to resist the simultaneous application of a static lateral force of 585 N/m (40 lbf/ft) and a vertical load of 730 N/m (50 lbf/ft) applied to the top of the handrail stand.</p>	<p>JEAS-525 EXP.3.2 Balustrades shall be designed to resist the simultaneous application of a static lateral force of 600 N and a vertical force of 730 N both equally distributed over a length of 1 m and acting on the top of the handrail guiding system in the same place.</p>

EN 115-1 (Europe)	A17.1/B44 (North America)	Japanese codes
<p>5.5.2.4 The parts of the balustrade facing the steps, pallets, or belt shall be smooth and flush. Covers not in the direction of travel shall not project more than 3 mm. They shall be rigid and have rounded or bevelled edges. Covers of such nature are not permitted at the skirting.</p> <p>Cover joints in the direction of travel (in particular, between the skirting and the interior panel) shall be arranged and formed in such a manner as to eliminate any risk of harm caused by trapping.</p> <p>Gaps between the interior panels of the balustrade shall be not wider than 4 mm. The edges shall be rounded off or bevelled.</p> <p>When a force of 500 N is applied to the interior panel at any point of the panelling at right angles on an area of 25 cm², there shall be no gap greater than 4 mm and no permanent deformation.</p>	<p>6.1.3.3.1/6.2.3.3.1 Construction</p> <p>(a) For</p> <p>(1) escalators not equipped with dynamic skirt panels, the balustrade on the step side shall have no areas or moldings depressed or raised more than 6,4 mm (0.25 in.) from the parent surface, except as permitted in 6.1.3.3.10;</p> <p>(2) escalators equipped with dynamic skirt panels, the balustrade on the step side shall have no areas or moldings parallel to the direction of travel that are depressed or raised more than 12 mm (0,47 in.) from the parent surface.</p> <p>(b) The balustrade shall be totally closed, except</p> <p>(1) where the handrail enters the newel base (see 6.1.3.4.3/6.2.3.4.3);</p> <p>(2) gaps between interior panels shall be not wider than 5 mm (0,19 in.). The edges shall be rounded or beveled.</p> <p>(3) where the dynamic skirt panels enter the balustrade [see 6.1.3.3.7(c)].</p> <p>(c) The width between the balustrade interior panels in the direction of travel shall not be changed.</p>	<p>BSLJ-E0; Article 129-12</p> <p>1. (1) As specified by the minister of land, infrastructure, and transport, escalators shall be devised so as persons or articles not to be caught and so as not to be collide with obstacles under the normal using condition.</p> <p>MOC-N (No.1417-2000)</p> <p>EXP.1. The escalator of this notification includes moving walks and escalator for person sitting on wheelchair Further, the interior panel should be smooth and durable construction without rugged portion as much as possible and it should be installed so as not to catch hands or fingers of the passengers.</p>
<p>If glass is used for the interior panel, it shall be toughened glass. The minimum thickness of 6 mm shall apply to single layer balustrades. When multi-layer glass balustrades are used, they shall be laminated toughened glass, the thickness of at least one layer shall also be not less than 6 mm.</p>	<p>6.1.3.3.3/6.2.3.3.3 Use of glass or plastic. Glass or plastic, if used in balustrades, shall conform to the requirements of the following standards, whichever is CFR Part 1201, or</p> <p>(b) one of the following CGSB Standards: CAN/CGSB-12.1, CAN/CGSB-12.11, or CAN/CGSB-12.12, except that there shall be no requirement for the panels to be transparent.</p> <p>Plastic bonded to basic supporting panels is not required to conform to these requirements.</p>	<p>JEAS-525 3.1</p> <p>If glass is used for the interior panel, it shall be toughened glass (equivalent of JIS R3206) and at least 6 mm thickness.</p> <p>The glass with shatterproof film (equivalent of JIS A5759 class GS or SF) shall be provided to reduce the risk when self-destruction of glass is developed.</p>
<p>5.5.2.5 The horizontal distance (measured at right angles to the direction of travel) between the interior panel at lower points shall be equal to or less than the horizontal distance measured at points higher up.</p>	<p>—</p>	

EN 115-1 (Europe)	A17.1/B44 (North America)	Japanese codes
—	—	<p>BSLJ-EO; Article 129-12</p> <p>1.(4) The width of the steps shall be not more than 1,1 m and the horizontal distance between the side edge of the steps and centre of the handrail at the said side of the steps shall be not more than 25 cm.</p> <p>BSLJ-EO; Article 129-12</p> <p>EXP.1.(4)</p> <p>The width of the steps shall be not more than 1,1 m and the horizontal distance between the side edge of the steps and centre of the handrail at the said side of the steps shall be not more than 25 cm(i.e. distance between handrails is no more than 1,6 m).</p> <p>The width of the steps for moving walk with inclination less than 4° is less than 1,6 m and distance from side edge of step to centre of handrail is not more than 0,25 m (i.e. distance between handrails is not more than 2,1 m)</p> <p>(MOC-N(No.1413-2000)2-2.)</p> <p>Generally, two kinds of the escalator with step width of 600 mm (past 800 type) and 1 000 mm (past 1 200 type) are available. They are called as S600 type and S1000 type.</p>
<p>5.5.2.6 The lower inner decking and the interior panel shall have an angle of inclination, γ, of at least 25° to the horizontal (see Figure 3).</p>	<p>6.1.3.3.4/6.2.3.3.4 Interior low deck. The interior low deck, where provided, shall conform to the following (see Nonmandatory Appendix I, Fig. I-1/9).</p> <p>(b) The angle between the surface of the deck and the plane of the nose line of the steps/the treadway shall be not less than 20° nor more than 30°.</p>	—
<p>This does not apply to the horizontal part of the lower inner decking that directly joins the interior panel (see b_4 in Figure 3).</p>	—	—
<p>5.5.2.6.1 The horizontal part, b_4, up to the interior panel shall be less than 30 mm.</p>	<p>(c) A horizontal section shall be permitted immediately adjacent to the interior panel. It shall be not greater than 35 mm (1,25 in.).</p>	

EN 115-1 (Europe)	A17.1/B44 (North America)	Japanese codes
<p>5.5.2.6.2 The width, b_3, measured horizontally of each lower inner decking inclined at an angle of less than 45° to the horizontal shall be less than 0,12 m (see Figure 3).</p>	<p>(a) The width from the vertical face of the interior panel to the vertical plane of the skirt panel or dynamic skirt panel cover, where provided, shall not exceed 150 mm (6 in.).</p> <p>6.1.3.3.4 (d) The deck and the dynamic skirt panel cover, where provided, at the point closest to the step shall withstand a force of 900 N (200 lbf) perpendicular to the line of attachment of the element without detachment or permanent deformation. The force shall be applied to an area of 645 mm² (1 in.²).</p>	<p>BSLJ-EO; Art. 129-12, 1(4)</p> <p>The horizontal distance between the side edge of the steps and centre of the handrail at the corresponding side of the steps shall be not more than 25 cm</p>
<p>Skirting</p> <p>5.5.3.1 The skirting shall be vertical, plain, and butt-jointed</p>	<p>—</p>	<p>—</p>
<p>NOTE However, special arrangements instead of butt-jointing (e.g. sliding joints) will possibly be necessary for long moving walks at the points where they pass over building expansion joints.</p>	<p>6.1.3.3.6/6.2.3.3.6 Skirt panels</p> <p>(c)/(d)The exposed surfaces of the skirt panels adjacent to the steps/the tread shall be smooth.</p>	<p>—</p>
<p>5.5.3.2 The perpendicular distance, h_2, between top edge of skirting or bottom edge of projecting cover joints or the lower edge of the rigid part of skirt deflectors (for definition, see 3.1.26) and the line of the step nose or the tread surface of the pallets or belt shall be not less than 25 mm (see Figure 3).</p>	<p>6.1.3.3.6/6.2.3.3.6 Skirt panels</p> <p>(a)/(b) The height of the skirt above the tread nose line/top of the tread shall be at least 25 mm (1 in.) measured vertically (see Nonmandatory Appendix I, Fig. I-4).</p>	<p>—</p>
<p>5.5.3.3 The skirting shall yield not more than 4 mm under a single force of 1 500 N acting at the most unfavourable point at right angles to the surface over an area of 2 500 mm² using a square or round area. No permanent deformation shall result from this.</p>	<p>6.1.3.3.6/6.2.3.3.6 Skirt panels</p> <p>(b)/(c) Skirt panels shall not deflect more than 1,6 mm (0,0625 in.) under a force of 667 N (150 lbf)⁴⁾</p> <p>⁴⁾ A17.1/B44 is equivalent to EN 115-1. A deflection of 4 mm would require 1667 N.</p>	<p>—</p>

EN 115-1 (Europe)	A17.1/B44 (North America)	Japanese codes
<p>5.5.3.4 On escalators, the possibility of trapping between skirting and steps shall be minimized.</p> <p>For this purpose, the following four conditions shall be fulfilled:</p> <p>a) sufficient rigidity of the skirting according to 5.5.3.3;</p> <p>b) clearances to be in accordance with 5.5.5.1;</p> <p>c) installation of skirt deflectors which fulfil the following requirements:</p>	<p>6.1.3.3.6/6.2.3.3.6 Skirt panels (c)/(d) The exposed surfaces of the skirt panels adjacent to the steps/tread shall be smooth.</p> <p>6.1.3.3.7 Dynamic skirt panels. Dynamic skirt panels, where provided, shall conform to the following:</p> <p>(a) the height of the dynamic skirt panel above the step tread nose line shall be at least 25 mm (1 in.) measured vertically (see Nonmandatory Appendix I, Fig. I-4);</p>	<p>BSLJ-EO; Art. 129-12, 1(1) The construction of escalator devised so as persons or articles not to be caught</p> <p>MOC-N (No.1417-2000); The construction of escalator devised so as persons or articles not to be caught, not to be collide with obstacles prescribed by BSLJ-EO; Article 129-12 item 1 paragraph 1, shall be specified as follows (1), (2), and (3).</p>
<ul style="list-style-type: none"> - they shall consist of a rigid and a flexible part (e.g. brushes, rubber profiles); - they shall have a minimum projection of 33 mm and a maximum of 50 mm from the vertical face of the skirt panels; - they shall withstand a force of 900 N uniformly distributed on the projected area of the rigid part over a rectangular area of 600 mm² vertically to the line of attachment of the rigid part without detachment or permanent deformation; - the rigid parts shall have a horizontal projection of between 18 mm and 25 mm and withstand the defined strength requirements. The horizontal projection of the flexible part shall have a minimum of 15 mm and a maximum of 30 mm; - a distance of between 25 mm and 30 mm shall be provided between the lowest part of the underside of the rigid part and perpendicular to the line of the step nose throughout the inclined portion of travel; - the distance between the lowest part of the underside of the rigid part of the skirt deflector and the top of any step cleat in the transition and horizontal areas shall be between 25 mm and 55 mm; - the lower surface of the rigid part shall be bevelled not less than 25° upward and the upper surface shall 	<p>(b) the exposed surfaces of the dynamic skirt panels adjacent to the step treads shall be smooth and in one plane. Exposed edges shall be rounded or bevelled;</p> <p>(c) guarding shall be provided at the point where the dynamic skirt panels enter the balustrade. The clearance between the guard and the dynamic skirt panels shall not exceed 3 mm (0,125 in.);</p> <p>(d) the exposed panels that comprise the dynamic skirt shall overlap or interlock such that no clear-through spaces exist. The distance between exposed edges of dynamic skirt panel elements shall not exceed 4 mm (0,16 in.);</p> <p>(e) there must be a positive mechanical connection between the dynamic skirt panels and the running gear;</p> <p>(f) the distance between the dynamic skirt panel and the dynamic skirt panel cover shall not exceed 5 mm (0,20 in.);</p> <p>6.1.3.3.8 Dynamic skirt panel loaded gap. The gap clearance (loaded gap) at any point between the step tread and the adjacent dynamic skirt panel shall not exceed 5 mm (0,20 in.) when 110 N (25 lbf) is laterally applied from the step to the adjacent dynamic skirt panel. The applied load shall not deviate from 110 N (25 lbf) by more than ±11 (2,5 lbf). The load shall be distributed over an area not less than 1 940 mm² (3 in.²) and not more than 3 870 mm² (6 in.²).</p>	<p>1.(1) The clearance between the steps and the skirt guard panel should not exceed 5 mm.</p> <p>EXP.1.(1) The horizontal clearance between the steps and the skirt guard panel (at one side) should not exceed 5 mm in the condition that no force is acting on the skirt guard panel when the escalator stands still. For the moving walks in which the skirt guard panel is placed above the steps, the vertical clearance between the tread surface and lower portion of the skirt guard panel should not exceed 5 mm when the escalator stands still.</p> <p>MOC-N (No. 1424-2000), 1(2)(d) (2) It shall be that the escalators are provided with devices to detect the situations described following (a) to (e).</p> <p>(d)The person or the articles are caught between a side of the step and the skirt guard panels near the riding entrance and leaving exit.</p> <p>JIS A 4302 5.4.2 (h) The skirt guard switches are required for escalator only.</p>

EN 115-1 (Europe)	A17.1/B44 (North America)	Japanese codes
<p>be bevelled not less than 25° downward from skirt panel;</p> <p>- the deflectors shall be designed with rounded edges. Fastening heads and joint connections shall not extend into the path of travel;</p> <p>- the terminal end piece shall be tapered to give a flush interface with the skirting. The terminal end piece of any deflector device shall end not less than 50 mm and maximum 150 mm prior to the comb intersection line;</p> <p>- if the skirt deflector is an extension of the lower inner decking, 5.5.2.6.2 applies. If the skirt deflector is attached or an integral part of the skirting, 5.5.3.1 apply;</p> <p>d) use of suitable materials or suitable type of lining underneath the deflector device in order to achieve a coefficient of friction for leather (wet and dry), PVC (dry), and rubber (dry) less than 0,45 (for information on test methods, see Annex K).</p> <p><i>(Figure 1 Requirements on skirt deflectors)</i></p>	<p>6.1.3.3.9 Step/skirt performance index</p> <p>(a) This requirement is not applicable to escalators with dynamic skirt panels. The step/skirt performance index, when the escalator is subjected to the test specified in 8.11.4.2.19, shall be the maximum value of the recorded instantaneous step/skirt index $e^y / (e^y + 1)$ where:</p> <p><i>(SI units)</i></p> <p>$e = 2,7\ 183;$</p> <p>$y = -3,77 + 2,37 (\mu) + 0,37 (L_g);$</p> <p>$\mu$ = the sliding coefficient of friction of a polycarbonate test specimen on the skirt panel at the measurement point calculated when subjected to a 110 N normal load. The coefficient of friction shall be measured without addition of any field-applied lubricant;</p> <p>L_g = the clearance between the step and the adjacent skirt panel when 110 N is applied from the step to skirt panel, mm.</p> <p>The applied load shall not deviate from 110 N by more than ± 11 N. The load shall be distributed over a round or square area not less than 1 940 mm² and not more than 3 870 mm².</p> <p><i>(Imperial units)</i></p> <p>$e = 2,7183$</p> <p>$y = -3,77 + 2,37 (\mu) + 9,3 (L_g)$</p> <p>$\mu$ = the sliding coefficient of friction of a polycarbonate test specimen on the skirt panel at the measurement point calculated when subjected to a 25 lbf normal load. The coefficient of friction shall be measured without addition of any field-applied lubricant.</p> <p>L_g = the clearance between the step and the adjacent skirt panel when 25 lbf is applied from the step to skirt panel, in.</p>	

EN 115-1 (Europe)	A17.1/B44 (North America)	Japanese codes
	<p>The applied load shall not deviate from 25 lbf by more than $\pm 2,5$ lbf. The load shall be distributed over a round or square area not less than 3 in.² and not more than 6 in.²</p> <p>(b) The step/skirt performance index polycarbonate test specimen shall conform to the following specifications.</p> <p>(1) Material: Polycarbonate without fillers, μ.</p> <p>(2) Colour: Natural, no pigments.</p> <p>(3) Finish: Glossy (roughness less than 0,8 μm (32 $\mu\text{in.}$)).</p> <p>(4) Area in contact with skirt panel: 2 900 mm² \pm 325 mm² (4,5 \pm 0,5 in.²) and at least 0,8 mm (0,03 in.) thick</p> <p>(5) Specification: GE Lexan 100 series or equivalent polycarbonate.</p> <p>(c) The escalator step/skirt performance index shall be either of the following:</p> <p>(1) $\leq 0,15$;</p> <p>(2) $\leq 0,25$ when a skirt deflector device complying with the requirements of 6.1.3.3.10 is provided.</p>	
	<p>6.1.3.3.10 Skirt deflector devices. Deflector devices shall be permitted. Where provided, deflector devices shall extend from skirt panels parallel to the escalator path of travel. Means to secure such deflector devices are permitted to be on the exposed surface of the skirt. Any exposed fastener heads shall be of the tamper-resistant type and flush to within 1 mm (0,04 in.).</p> <p>(a) Rigid elements shall be in conformance with the following conditions:</p> <p>(1) horizontal protrusions extending above the step shall be 18 mm (0,75 in.) maximum. Corners or changes in profile shall be rounded or beveled. The exposed surfaces of such elements shall be smooth and permanently treated with a low-friction material;</p>	

EN 115-1 (Europe)	A17.1/B44 (North America)	Japanese codes
	<p>(2) on the incline, the area of any protrusion shall lie entirely above a line on the skirt panel positioned at least 25 mm (1 in.) vertically above the step nose line. The lower surface shall be beveled not less than 10 deg upward and the upper surface shall be beveled not less than 15° downward (see Figure 6.1.3.3.8);</p> <p>(3) at the upper and lower landing, any protrusion shall lie entirely above a line on the skirt panel positioned at least 50 mm (2 in.) vertically above the step nose line. The lower surface shall be beveled not less than 10° upward and the upper surface shall be beveled not less than 15° downward. Any rigid elements at the landings shall smoothly blend into the rigid elements along the incline in accordance with the radius of curvature of the transition zone;</p> <p>(4) when attached to the skirt, rigid elements shall withstand a force of 900 N (200 lbf) perpendicular to the line of attachment of the element without detachment or permanent deformation. The force shall be applied to an area of 645 mm² (1 in.²);</p> <p>(b) Flexible elements shall be in conformance with the following conditions:</p> <p>(1) the horizontal protrusion extending from the skirt surface above the step shall be 50 mm (2 in.) maximum;</p> <p>(2) they shall be capable of deflecting to an angle of 10° or greater above the horizontal;</p> <p>(3) noncontinuous flexible elements shall be allowed to deflect to allow a maximum of 9,5 mm (0,375 in.) interference with any point on the step surface;</p> <p>(4) continuous flexible elements shall not deflect such that they can contact the steps.</p>	

EN 115-1 (Europe)	A17.1/B44 (North America)	Japanese codes
(5.5.3.5)	<p>6.1.3.5.6 Step demarcation. There shall be demarcation lines on the step tread along the back of the step to delineate the division between steps. These lines shall be marked by a yellow strip a minimum of 38 mm (1,5 in.) in width and a maximum of 50 mm (2 in.) [see 6.1.3.5.1(b)].</p> <p>There shall be demarcation lines on the step tread along the sides of the step. These side lines shall be yellow and at least 13 mm (0,5 in.) wide and shall not exceed 50 mm (2 in.) [see 6.1.3.5.1(b)].</p>	<p>JIS A 4302-2006, 5.4.2</p> <p>(k) The safety marks on steps shall be clear.</p> <p>NOTE The colour of safety mark is yellow or orange.</p>
<p>5.5.4 Newel</p> <p>5.5.4.1 The newel including the handrails shall project horizontally beyond the comb intersection line by at least 0,60 m in longitudinal direction (see L_2 and l_2 in Figure 2 and detail X).</p>	—	—
<p>5.5.4.2 The horizontal portion of the handrail shall continue longitudinally at the landings for a distance l_3 (see Figure 2) of at least 0,30 m past the comb intersection line (see L_2 in Figure 2 and detail X).</p> <p>In the case of inclined moving walks without a horizontal section at the landings, the continuation of the handrail parallel to the angle of inclination is permitted.</p>	<p>6.1.3.4.2 Extension beyond combplates. Each moving handrail shall extend at normal handrail height not less than 300 mm (12 in.) beyond the line of points of the combplate teeth at the upper and lower landings.</p> <p>6.2.3.4.2 Extension beyond combplates. The moving handrail at both the entrance and exit landings shall extend at normal height not less than 300 mm (12 in.) beyond the end of the exposed treadway. The point at which the moving handrail enters or leaves an enclosure shall be not more than 250 mm (10 in.) above the floor line.</p>	<p>MOC-N (No.1417-2000)</p> <p>EXP. 2.</p> <p>[Notice for designing]</p> <p>(2) The horizontal distance of the handrail from the comb to the edge of handrail return section (newel) shall not be less than 0,3 m for a speed of more than 0,5 m/s as a guide range in order that passengers may be guided properly (to secure stable position) between the floor cover and the step.</p>

EN 115-1 (Europe)	A17.1/B44 (North America)	Japanese codes
<p>5.5.5 Clearance between steps, pallets or belt, and skirting</p> <p>5.5.5.1 Where the skirting of escalators or moving walk is placed beside the steps and pallets or the belt the horizontal clearance shall not exceed 4 mm at either side and 7 mm for the sum of clearances measured at both sides at two directly opposite points.</p>	<p>6.1.3.3.5 Loaded gap between skirt and step. The clearance (loaded gap) between the step tread and the adjacent skirt panel shall be not more than 5 mm (0,2 in.) when 110 N (25 lbf) is laterally applied from the step to the adjacent skirt panel. The applied load shall not deviate from 110 N (25 lbf) by more than ±11 (2,5 lbf). The load shall be distributed over an area not less than 1 940 mm² ((3 in.²) and not more than 3 870 mm² (6 in.²).</p>	<p>MOC-N (No.1417-2000)</p> <p>1 (1) The clearance between the steps and the skirt guard panel should not exceed 5 mm.</p> <p>EXP.1.(1) The horizontal clearance between the steps and the skirt guard panel (at one side) should not exceed 5 mm in the condition that no force is acting on the skirt guard panel when the escalator stands still. For the moving walks in which the skirt guard panel is placed above the steps, the vertical clearance between the tread surface and lower portion of the skirt guard panel should not exceed 5 mm when the escalator stands still.</p> <p>JIS A 4302-2006; 5.4.2</p> <p>(h) The clearance between adjoining steps and that between skirt guard and steps shall be not exceed 5 mm over the whole length of escalator.</p>
<p>5.5.5.2 Where the skirting of moving walks finishes above the pallets or the belt, the clearance shall not exceed 4 mm measured vertically from the tread surface. Motion of the pallets or the belt in lateral direction shall not cause a gap between the sides of the pallets or the belt and the vertical projection of the skirting.</p>	<p>6.2.3.3.5 Skirtless balustrade. On moving walks where the balustrade covers the edge of the treadway</p> <p>(a) The clearance between the top surface of the treadway and the underside of the balustrade shall not exceed 6 mm (0,25 in.)</p> <p>(b) The balustrade shall be vertical and smooth for at least 25 mm(1 in.) including the 6 mm(0,25 in.) clearance above the top of the tread.</p>	
<p>5.6 Handrail system</p> <p>5.6.1 General</p> <p>On the top of each balustrade, there shall be provided a handrail moving in the same direction and at a speed tolerance of -0 % to +2 % relative to the actual speed of the steps, pallets, or belt under normal operating conditions.</p>	<p>6.1.3.4/6.2.3.4 Handrails</p> <p>6.1.3.4.1/6.2.3.4.1 Type required. Each balustrade shall be provided with a handrail moving in the same direction and at substantially the same speed as the steps/treadway. In the case of curved escalators, this shall be substantially the same angular velocity.</p>	<p>BSLJ-EO; Article 129-12</p> <p>1.(3) Escalators shall be provided with handrails at each side of steps (the portion going up and down, on which the persons step). The upper surface of the handrails shall move in the same direction and at the same speed as the steps.</p> <p>JIS A 4302-2006, 5.4.2 (d)</p> <p>A handrail shall be moved in the same direction and at substantially the same speed as the steps.</p>

EN 115-1 (Europe)	A17.1/B44 (North America)	Japanese codes
—	The speed of the handrail shall not change when a retarding force of 450 N (100 lbf) is applied to the handrail opposite to the direction of travel.	JIS A 4302-2006; 5.4.2 Inspection to be carried out on upper and lower landings and on steps (e) During downward operation, the handrail shall not be stopped by a human power of about 15 kgf (150 N) pulling horizontally at the upper landing.
A handrail speed monitoring device [see Table 6 m)] shall be provided and shall stop the escalator or moving walk in the event of a hand rail speed deviation of more than -15 % to the actual speed for more than 15 s while the escalator or moving walk is in motion.	6.1.6.4/6.2.6.4 Handrail-speed monitoring device. A handrail speed monitoring device shall be provided that will cause the activation of the alarm required by 6.1.6.3.1(b)/6.2.6.3.1(b) without any intentional delay whenever the speed of either handrail deviates from the step speed by 15 % or more. The device shall also cause electric power to be removed from the driving-machine motor and brake when the speed deviation of 15 % or more is continuous within a 2 s to 6 s range. The device shall be of the manual-reset type.	—
5.6.2 Profile and position 5.6.2.1 The handrail profiles and their guides on the balustrades shall be formed or enclosed in such a way that the possibility of pinching or trapping of fingers or hands is reduced. The distance between the handrail profile and guide or cover profiles shall under no circumstances be wider than 8 mm (see b_6' and b_6'' in Figure 3, detail W).	6.1.3.4.6/6.2.3.4.5 Handrail clearance. The horizontal clearance between either lip of the handrail and the handrail stand shall not exceed 10 mm (0,375 in.) (see Nonmandatory Appendix I, Fig. I-2).	—
—	6.1.3.4.4/6.2.3.4.4 Splicing. Splicing of handrails shall be done in such a manner that the joint is free of any pinching effect.	—
5.6.2.2 The width b_2 of the handrail shall be between 70 mm and 100 mm (see Figure 3, detail W).	—	—
5.6.2.3 The distance b_5 between the handrail and the edge of the balustrade shall not exceed 50 mm (see Figure 3).	—	—

EN 115-1 (Europe)	A17.1/B44 (North America)	Japanese codes
<p>5.6.3 Distance between the handrail centre lines</p> <p>The distance b_1 between the centre line of the handrails shall not exceed the distance between the skirting by more than 0,45 m (see b_1 and z_2 in Figure 3).</p>	<p>6.1.3.2.2/6.2.3.2.3 Geometry. The handrail shall be a minimum of 100 mm (4 in.) horizontally and 25 mm (1 in.) vertically away from adjacent surfaces, except that rounded fillets or beveled sides of the handrail stand are permitted to reduce the 25 mm (1 in.) clearance between the handrail and the point where the handrail stand is connected to the balustrade. The centerline of the handrail shall be not more than 240 mm (9,5 in.), measured horizontally, from the vertical plane through the edge of the exposed step (see Nonmandatory Appendix I, Figs. I-1 and I-2/Fig. I-9).</p>	<p>BSLJ-EO; Article 129-12</p> <p>1.(4) The width of the steps shall be not more than 1,1 m and the horizontal distance between the side edge of the steps and centre of the handrail at the said side of the steps shall be not more than 25 cm.</p> <p>BSLJ-EO; Article 129-12</p> <p>EXP 1.(4) The width of the steps shall be not more than 1,1 m and the horizontal distance between the side edge of the steps and centre of the handrail at the said side of the steps shall be not more than 25 cm (i.e. distance between handrails is no more than 1,6 m).</p> <p>The width of the steps for moving walk with inclination less than 4° is less than 1,6 m and distance from side edge of step to centre of handrail is not more than 0,25 m (i.e. distance between handrails is not more than 2,1 m).</p> <p>MOC-N (No. 1413-2000), 2(2)(c)</p> <p>For wide pallet/belt greater than 1,1m the horizontal distance between the side edge of the steps and centre of the handrail at the said side of the steps shall be not more than 25 cm.</p> <p>MOC-N (No. 1413-2000), 2(3)(f)</p> <p>For variable speed moving walk: The horizontal distance between the side edge of the steps and centre of the handrail at the said side of the steps shall be not more than 25 cm.</p>
<p>5.6.4 Handrail entry</p> <p>5.6.4.1 The lowest point of entry of the handrail into the newel shall be at a distance, h_3, from the floor which shall be not less than 0,10 m and not exceed 0,25 m (see Figures 2 and 3).</p>	<p>—</p>	<p>—</p>
<p>5.6.4.2 The horizontal distance, l_4, between the furthest point reached by the handrail and the point of entry into the newel shall be at least 0,30 m (see Figure 2).</p>	<p>—</p>	<p>—</p>
<p>If l_4 is greater than $(l_2 - l_3 + 50 \text{ mm})$ the handrail shall enter into the balustrade at an angle of at least 20° measured to the horizontal.</p>	<p>—</p>	<p>—</p>

EN 115-1 (Europe)	A17.1/B44 (North America)	Japanese codes
<p>5.6.4.3 At the point of entry of the handrail into the newel a guard shall be installed to prevent the pinching of fingers and hands.</p> <p>A switch according to Table 6 i) shall be provided.</p>	<p>6.1.3.4.3/6.2.3.4.3 Guards. Hand or finger guards shall be provided at a point where the handrail enters the balustrade.</p> <p>6.1.6.3.12/6.2.6.3.10 Handrail entry device. A handrail entry device shall be provided at each newel. It shall be operative in the newels in which the handrail enters the balustrade. It shall be of the manually reset type and shall cause the escalator/moving walk to stop by removing power from the driving-machine motor and brake. It shall operate in either of two ways:</p> <p>(a) if an object becomes caught between the handrail and the handrail guard;</p> <p>(b) if an object approaches the area between the handrail and the handrail guard.</p> <p>For those units that rely on an opening of the balustrade to prevent entrapment, all handrail entry devices shall be operative whenever the handrails are operating.</p>	<p>MOC-N (No.1424-2000)</p> <p>2. The construction method of the braking devices for the escalator shall conform to each paragraph described below.</p> <p>It shall be that the escalators are provided with devices to detect the situations described following (a) to (e). [except (d)] for the escalator of which inclination is less than 15° and a difference in level between each adjacent steps (except the difference in level that the angle at the nose in the direction of movement of the higher level step is not more than 15°) is less than 4 mm)</p> <p>(e)The person or the articles are caught in the inlet of the handrail.</p> <p>JIS A 4302-2006 5.4.2 (f)</p> <p>Switches shall be incorporated in the guards which are fixed at the inlets of the handrails and shall have functions to stop the escalator if an article is forced into the guards.</p>
<p>5.6.5 Guiding</p> <p>The handrail shall be guided and tensioned in such a way that it will not leave its guides during normal use.</p>	<p>—</p>	<p>—</p>
<p>5.7 Landing</p> <p>5.7.1 Surface properties</p> <p>The landing area of escalators and moving walks (i.e. comb plate and floor plate) shall have a surface that provides a secure foothold for a minimum distance of 0,85 m measured from the root of the comb teeth (see L_1 in Figure 2 and detail X). Exempt from this are the combs mentioned in 8.3.</p> <p>NOTE For definition of materials and test methods, see Annex J.</p> <p>Exempt from this are the combs mentioned in 5.7.3.</p>	<p>6.1.3.5.1 Material and type</p> <p>(c) Step treads shall be horizontal, and shall afford a secure foothold. The step supporting system shall be so designed so that the back of the step cannot tip upward more than 6 mm (0,25 in.) at any point.</p> <p>6.2.3.5.5 Material and type</p> <p>(c) Pallet treads shall afford a secure foothold.</p>	<p>—</p>

EN 115-1 (Europe)	A17.1/B44 (North America)	Japanese codes
<p>5.7.2 Configuration of steps, pallets, and belts</p> <p>5.7.2.1 At the landings, the steps of the escalator shall be guided in such a way that the front edges of the steps leaving the comb and the rear edges of the steps entering the comb are moving horizontally for a length of at least 0,80 m measured from point L_1 (see Figure 2 and detail X).</p> <p>At nominal speeds above 0,50 m/s and not more than 0,65 m/s, or rises, h_{13}, above 6 m this length, shall be at least 1,20 m, measured from point L_1 (see Figure 2 and detail X).</p> <p>At nominal speeds above 0,65 m/s, this length shall be at least 1,60 m measured from point L_1 (see Figure 2 and detail X).</p> <p>A vertical difference in level between two consecutive steps of 4 mm is permitted.</p>	<p>6.1.3.6.5 Flat steps. There shall be a minimum of two and a maximum of four flat steps at the entrance and exit of every escalator.</p> <p>6.2.3.5.3 Alignment of pallet tread surfaces. Adjacent ends of pallets shall not vary in elevation more than 1,6 mm (0,06 in.).</p>	<p>MOC-N (No. 1413-2000), 2(1)</p> <p>(e) 2 flat steps with max 4 mm difference in level for more than 30°.</p> <p>NOTE No requirement for numbers of flat steps of escalator with not grater than 30°.</p>
<p>5.7.2.2 For escalators, the radius of curvature in the upper transition from incline to horizontal shall be the following:</p> <ul style="list-style-type: none"> - at least 1,00 m for rated speeds $v \leq 0,5$ m/s (inclination max. 35°); - at least 1,50 m for nominal speeds $0,5$ m/s $< v \leq 0,65$ m/s (inclination of max 30°); - at least 2,60 m for nominal speeds $v > 0,65$ m/s (inclination of max 30°). <p>The radius of curvature in the lower transition from incline to horizontal of the escalator shall be at least 1,00 m up to 0,65 m/s the nominal speed and at least 2,00 m above 0,65 m/s.</p>	<p>—</p>	<p>—</p>
<p>5.7.2.3 For belt moving walks, the radius of curvature in the transition from incline to horizontal shall be at least 0,40 m.</p> <p>For pallet moving walks, it is not necessary to determine the radius of curvature because on account of the maximum permissible distance between two consecutive pallets (see 5.3.5) it will always be sufficiently large.</p>	<p>—</p>	<p>—</p>

EN 115-1 (Europe)	A17.1/B44 (North America)	Japanese codes
<p>5.7.2.4 At the upper landings of moving walks with an inclination of more than 6°, the pallets or belt shall move for a length of at least 0,40 m at a maximum angle of 6° before entering or leaving the comb.</p> <p>Analogous to 5.7.2.1, for pallet passenger conveyors, the movement is specified as follows.</p> <p>The front edge of the pallet leaving the comb and the rear edge of the pallet entering the comb shall move without changing the degree of angle over at least 0,40 m.</p>	<p>6.2.3 Construction requirements</p> <p>6.2.3.1 Angle of inclination</p> <p>The angle of inclination from the horizontal shall not exceed 3° within 900 mm (3 ft) of the entrance and exits and shall not exceed 12° at any point.</p>	—
<p>5.7.2.5 Provisions shall be made in the area of the combs to ensure the correct meshing (see 5.7.3.3) of the comb teeth with the grooves of the tread surface.</p> <p>Belts shall be supported in this area in a suitable manner, e.g. by drums, rollers, sliding plates.</p>	<p>6.1.3.6.1/6.2.3.8.1 Combplates</p> <p>(c) Combplates shall be adjustable vertically. Sections forming the comb teeth shall be readily replaceable.</p> <p>(d) The comb section, combplate, and landing plate assemblies shall not make contact with the step treads/pallet or belt treadway surfaces when a weight of 160 kg (350 lb) applied to any area 200 mm × 300 mm (8 in. × 12 in.) centred on the plates with the 300 mm (12 in.) dimension parallel to the direction of travel.</p>	<p>JIS A 4302-2006, 5.4.2</p> <p>(g) The engagement between the grooves on the steps and the combplate teeth on the upper and lower landings shall be adequate enough, and there is no risk of easy jamming of things.</p>
<p>If any part of the step or pallet is sagging so that meshing of the combs is no longer ensured a safety device according to Table 6 j) shall be provided to stop the escalator or moving walk. This safety device shall be arranged before each transition curve at a sufficient distance before the comb intersection line to ensure that the step or pallet which has sagged does not reach the comb intersection line (see stopping distances defined in 5.4.2.1.3.2 and</p>	<p>6.1.6.3.11 Step level device. Step level devices shall be located at the top and bottom of the escalator. These devices shall detect downward displacement of 3 mm (0,125 in.) or greater at the riser end at either side of the step. When activated, the device shall cause the escalator to stop before the step enters the combplate. The device shall cause power to be removed from the driving-machine motor and brake. Devices shall be of the manual-reset type.</p>	—

EN 115-1 (Europe)	A17.1/B44 (North America)	Japanese codes
5.4.2.1.3.4). The monitoring device may be applied at any point of the step or pallet.	<p>6.2.6.3.9 Pallet level device. Moving walks equipped with pallets with trail wheels shall be provided with pallet level devices located at the top and bottom of the moving walk. These devices shall detect downward displacement of 3 mm (0,125 in.) or greater at the trailing edge of the pallet at either side of the pallet. When activated, the device shall cause the moving walk to stop prior to the pallet entering the combplate. The device shall cause power to be removed from the driving-machine motor and brake. Devices shall be of the manually reset type.</p>	
<p>5.7.3 Combs 5.7.3.1 General Combs shall be fitted at both landings to facilitate the transition of passengers. The combs shall be easily replaceable.</p>	<p>6.1.3.6/6.2.3.8 Entrance and egress ends 6.1.3.6.1/6.2.3.8.1 Combplates (a) There shall be a combplate to which the combs shall be fastened at the entrance and at the exit of every escalator/moving walk.</p>	
<p>5.7.3.2 Construction 5.7.3.2.1 The teeth of the combs shall mesh with the grooves of the steps, pallets, or belt (see 11.3 and 11.4). The width of the comb teeth shall be not less than 2,5 mm, measured at the tread surface.</p>	<p>6.1.3.6.1/6.2.3.8.1 Combplates (b) The comb teeth shall be meshed with and set into the slots in the tread surfaces so that the points of the teeth are always below the upper surface of the treads.</p>	<p>JIS A 4302-2006; 5.4.2 (g) The engagement between the grooves on the steps and the combplate teeth on the upper and lower landings shall be adequate enough and there is no risk of easy jamming of things.</p>
<p>5.7.3.2.2 The ends of the combs shall be rounded off and so shaped as to minimize the risk of trapping between combs and steps, pallets, or belt. The radius of the teeth end shall be not greater than 2 mm.</p>	—	—
<p>5.7.3.2.3 The teeth of the comb shall have a form and inclination so that the feet of passengers leaving the escalator or moving walk will not stub against them. The design angle, β, shown in Figure 2, detail X shall not exceed 35°.</p>	—	—
<p>5.7.3.2.4 The combs or their supporting structure shall be adjustable to ensure correct meshing (see Figure 2, detail X).</p>	<p>6.1.3.6.1/6.2.3.8.1 Combplates (c) Combplates shall be adjustable vertically. Sections forming the comb teeth shall be readily replaceable.</p>	—
<p>5.7.3.2.5 The combs shall have such a design that upon trapping of foreign bodies either their teeth deflect and remain in mesh with the grooves of the steps or pallets, or they break.</p>	—	—

EN 115-1 (Europe)	A17.1/B44 (North America)	Japanese codes
<p>5.7.3.2.6 In the case of objects being trapped which are not dealt with by the means described in 5.7.3.2.5 and in the case of comb/step/pallet, impact the escalator or moving walk shall be stopped automatically [see Table 6 g)].</p>	<p>6.1.6.3.13/6.2.6.3.11 Comb-step impact devices. Devices shall be provided that will cause the opening of the power circuit to the escalator/moving walk driving-machine motor and brake if either</p> <p>(a) a horizontal force not greater than 1 780 N(400 lbf) in the direction of travel is applied at either side or not greater than 3 560 N (800 lbf) at the centre of the front edge of the comb-plate, or</p> <p>(b) a resultant vertical force not greater than 670 N (150 lbf) in the upward direction is applied at the centre of the front of the combplate.</p> <p>These devices shall be of the manual-reset type.</p>	—
<p>(5.7.3.2.7)</p>	<p>6.1.3.6.2/6.2.3.8.2 Distinction between comb and step/treadway.</p> <p>There shall be a visual contrast between the comb and step/tread, achieved by colour, pattern, or texture.</p>	—
<p>5.7.3.3 Mesh depth of the combs into the grooves</p> <p>5.7.3.3.1 The mesh depth, h_8, of the combs into the grooves of the tread (see Figure 2, detail X) shall be at least 4 mm.</p>	<p>6.1.3.6.1/6.2.3.8.1 Combplates</p> <p>(b) The comb teeth shall be meshed with and set into the slots in the tread surfaces so that the points of the teeth are always below the upper surface of the treads.</p>	—
<p>5.7.3.3.2 The clearance, h_6, (see Figure 2, detail X) shall not exceed 4 mm.</p>	<p>6.1.3.6/6.2.3.8 Entrance and egress ends</p> <p>6.1.3.6.1/6.2.3.8.1 Combplates</p> <p>(d) The comb section, combplate, and landing plate assemblies shall not make contact with the step treads/pallet or belt treadway surfaces with a weight of 160 kg (350 lb) applied to any area 200 mm × 300 mm (8 in. × 12 in.) centred on the plates with the 300 mm (12 in.) dimension parallel to the direction of travel.</p>	—

EN 115-1 (Europe)	A17.1/B44 (North America)	Japanese codes
<p>5.8.1 General</p> <p>These rooms/spaces shall be used only for accommodating the equipment necessary for the operation and maintenance and inspection of the escalator or moving walk.</p> <p>Fire alarm systems, equipment for direct fire abatement, and sprinkler heads, provided they are sufficiently protected against incidental damage, are permitted in these rooms provided they do not generate additional risks for maintenance operation.</p> <p>NOTE See 7.4.1 d) for maintenance requirements and inspection activities.</p>	—	—
<p>According to ISO 12100-2:2003, Clause 5, effective protection shall be provided for rotating parts if they are accessible and dangerous, in particular, for the following:</p> <p>a) keys and screws in shafts; b) chains, belts; c) gears, gear wheels, sprockets; d) projecting motor shafts; e) speed governors not enclosed; f) step and pallet reversal in driving stations and/or return stations if these must be entered for maintenance purposes; g) hand wheels and brake drums.</p>	<p>6.1.7.3.4/6.2.7.3.4 Where access is provided to a machinery enclosure, a fixed guard shall be provided to prevent accidental contact with the moving steps/pallets and moving treadways by a person servicing equipment from within the enclosure. The guard shall be made of material that will reject a 13 mm (0,5 in.) diameter ball and shall extend the full width of the step/pallet treads. A guard is not required where the only equipment normally serviced from within the enclosure is within the step/pallet band.</p>	—
<p>5.8.2 Dimensions and equipment</p> <p>5.8.2.1 In machinery spaces, especially in driving and return stations inside the truss, space with a sufficiently large standing area shall be kept free from permanently installed parts of any kind. The size of the standing area shall be at least 0,30 m² and the smaller side shall be at least 0,50 m long.</p>	—	—
<p>5.8.2.2 If the controller cabinet has to be moved or lifted for maintenance purposes, then suitable attachments for lifting shall be provided, e.g. eyebolts, handle.</p>	—	—

EN 115-1 (Europe)	A17.1/B44 (North America)	Japanese codes
<p>5.8.2.3 Where the main drive or brake is arranged between the user side of the step, pallet, or belt and the return line, a level standing area in the working zone of not less than 0,12 m² shall be provided. The minimum dimension shall be not less than 0,30 m.</p> <p>This standing area is permitted to be fixed or removable.</p> <p>NOTE For machinery spaces, see also A.3.</p>	—	—
—	—	—
<p>5.8.3 Lighting and socket outlets</p> <p>5.8.3.1 The electric lighting and the socket outlets shall be independent of the power supply to the machine being fed either by a separate cable or a branch cable which is connected before the main switch of the escalator or moving walk.</p>	—	—
<p>It shall be possible to break the supply of all phases by means of a separate switch (see 5.11.4.1).</p>	—	—
<p>5.8.3.2 Electric lighting installations in driving and return stations and machinery spaces inside the truss shall be by means of a portable lamp permanently available in one of these places. One or more socket outlets shall be provided in each of these places.</p> <p>The light intensity shall be at least 200 lx in working areas.</p>	<p>6.1.7.1/6.2.7.1 Lighting of machine room and truss interior</p> <p>6.1.7.1.1/6.2.7.1.1 Remote machine room. Permanent electric lighting and a duplex receptacle rated at not less than 15 A, 120 V shall be provided in every remote machine room.</p> <p>The illumination shall be not less than 100 lx (10 fc) at the floor level. The lighting control switch shall be located within easy reach of the access to such rooms and so located that it can be operated without passing or reaching over any part of the machinery.</p> <p>6.1.7.1.2/6.2.7.1.2 Truss interior.</p> <p>A duplex receptacle rated at not less than 15 A, 120 V, accessibly located shall be provided under the access plates (see 6.1.7.3/6.2.7.3) at the top and bottom landings/both landings and in any machine areas located in the incline/within the moving walk.</p>	—
<p>5.8.3.3 Socket outlets shall be</p> <p>a) either of type 2 P + T (2 poles + earth conductor), 250 V, directly supplied by the mains;</p> <p>b) or of a type that is supplied at a safety extra low voltage in accordance with HD 60364-4-41.</p>	—	—

EN 115-1 (Europe)	A17.1/B44 (North America)	Japanese codes
<p>5.8.4 Maintenance and repair stop switch</p> <p>There shall be a stop switch in the driving and return station.</p> <p>Escalators and moving walks with the driving unit arranged between the user side of the step, pallet or belt, and the return line or outside the return stations shall have additional stop switches in the area of the driving unit.</p> <p>The operation of these stop switches shall cause the disconnection of the power supply from the driving machine and allow the operational brake to become effective to stop the escalator or moving walk.</p> <p>The stop switches shall be in accordance with ISO 13850 and achieve a category 0 stop.</p> <p>When activated it shall prevent the escalator or moving walk from starting.</p> <p>The switching positions shall be marked clearly and permanently.</p> <p>SPECIFIC CASE A stop switch need not be provided in a machinery space if a main switch according to 5.11.4 is located therein.</p>	<p>6.1.6.3.5/6.2.6.3.5 Stop switch in machinery spaces. A stop switch conforming to the following requirements shall be provided in each machinery space and other spaces where means of access to the interior space is provided (see 6.1.7.3/6.2.7.3), except for the machinery space where the main line disconnect switch is located.</p> <p>(a) When opened (“STOP” position), cause the electric power to be removed from the escalator driving machine motor and brake.</p> <p>(b) Be of the manually opened and closed type.</p> <p>(c) Have red operating handles or buttons.</p> <p>(d) Be conspicuously and permanently marked “STOP,” and shall indicate the “STOP” and “RUN” positions.</p> <p>(e) Shall have contacts that are positively opened mechanically and their opening shall not be solely dependent on springs.</p>	<p>—</p>

EN 115-1 (Europe)	A17.1/B44 (North America)	Japanese codes
<p>5.9 Fire protection</p> <p>Fire protection and building requirements differ from country to country and so far neither have been harmonized.</p> <p>Therefore, this standard cannot include specific requirements for fire protection and building requirements. However, it is recommended that as far as possible, escalators and moving walks are made of materials that do not create an additional hazard in case of fire.</p> <p>Outer and inner decking, truss, pallets/steps, and track system shall be at least class C according to EN 13501-1:2007, 11.5</p>	<p>6.1.1/6.2.1 Protection of floor openings</p> <p>6.1.1.1/6.2.1.1.1 Protection required. Floor openings for escalators/moving walks shall be protected against the passage of flame, heat, and/or smoke in accordance with the provisions of the building code (see Part 9).</p> <p>6.1.2/6.2.2 Protection of trusses and machine spaces against fire</p> <p>6.1.2.1/6.2.2.1 Protection required. The sides and undersides of an escalator/moving walk truss or group of adjacent trusses in a single wellway shall be enclosed in materials defined as either noncombustible or limited-combustible by the building code or ANSI/NFPA 101¹⁾. Means provided for adequate ventilation of the driving machine and control spaces, when included in the truss enclosure area, shall be permitted.</p> <p><i>1) The term "fire resistive materials" has been replaced with a specific specification to eliminate subjective interpretations by the enforcing authorities.</i></p> <p>6.1.3.5.1/6.2.3.5.5 Material and type</p> <p>(a) Step/pallet frames, treads, risers, and dynamic skirt panels, excluding the step's/their attachments or inserts, shall be metal, except that magnesium alloys shall not be used or the materials, in their end-use configuration, shall have a flame spread index of 0 to 50 based on the tests conducted in accordance with the requirements of ASTM E 84, UL 723, NFPA 255, or CAN/ULC-S102.2, whichever is applicable (see Part 9).</p> <p>(b) Nonmetallic attachments and inserts (excluding wheels) shall be classified 94 HB or better in accordance with ANSI/UL 94.</p>	<p>BSLJ; Article.34</p> <p>MOC-N (No.1418-2000)2(2)</p> <p>2. The escalator strength verification method shall conform to the following each item.</p> <p>(2) In the Art.129-12, item 2, the safety factor of step, frame, and truss or beam stipulated in Art.129-4, item 2, paragraph 3 of the Building Standard Law Enforcement Order applied mutatis mutandis shall be not less than the value described in the following table:</p> <p>(a) step shall be made by steel or other metals;</p> <p>(b) truss shall be made by steel.</p>

EN 115-1 (Europe)	A17.1/B44 (North America)	Japanese codes
<p>5.10 Transportation</p> <p>Complete escalators/moving walks or components of escalators/moving walks which cannot be handled by hand shall</p> <p>a) either be equipped with fittings for movement by a lifting device or transportation means,</p> <p>b) be designed in a way that such fittings can be attached (e.g. threaded holes), or</p> <p>c) be shaped in a way that the lifting device or transportation means can be attached easily.</p>	<p><i>(A17.1/B44 does not address this issue)</i></p>	<p>—</p>
<p>5.11 Electrical installations and appliances</p> <p>5.11.1 General</p> <p>The electrical installation of escalators or moving walks shall be so designed and manufactured as to ensure protection against hazards arising from the electrical equipment or which may be caused by external influences on it provided the equipment is used in applications for which it was made and is adequately maintained. Therefore, the electrical equipment shall</p>	<p>6.1.7.4/6.2.7.4 Electrical equipment and wiring</p> <p>6.1.7.4.1/6.2.7.4.1 All electrical equipment and wiring shall conform to NFPA 70 or CSA-C22.1, whichever is applicable (see Part 9). In jurisdictions enforcing CSA-C22.1, power supply-line disconnecting means shall not be opened automatically by a fire alarm system.</p> <p>6.1.7.4.2/6.2.7.4.2 Electrical equipment shall be listed/certified and labelled/marked. CSA-B44.1/ASME A17.5 defining the scope and applicable requirements</p>	<p>—</p>

EN 115-1 (Europe)	A17.1/B44 (North America)	Japanese codes
<p>a) comply with the requirements stated in the CENELEC harmonized standards;</p> <p>b) where no harmonized standards, as referred to in a) exist, comply with the requirements of the International Electrotechnical Commission (IEC) and which are stated in the CENELEC harmonized documents.</p> <p>Whenever one of these standards is used, its references are given together with the limits within which is used.</p>	<p>for this listing/certification.</p> <p>6.1.7.4.3/6.2.7.4.3 Control equipment shall be tested in accordance with the testing requirements of EN 12016 by exposing it to interference levels at the test values specified for “safety circuits.” The interference shall not cause any of the conditions described in 6.1.6.10.1 (a) through (f)/6.2.6.9.1 (a) through (e). If enclosure doors or suppression equipment must remain installed to meet the above requirements, warning signs to that effect shall be posted on the control equipment.</p> <p>ASME A17.5 Elevator and escalator electrical equipment. This code contains requirements for obtaining, labelling, and listing of drive machine controllers, logic controllers, and operating devices for starting, stopping, regulating, controlling, or protecting electric motors, generators, and all other electrical equipment, for elevators, escalators, moving walks, dumbwaiters, wheelchair lifts, and stairway lifts.</p>	
<p>5.11.1.2 Limits of application</p> <p>5.11.1.2.1 The requirements of this standard relating to the installation and to the constituent components of the electrical equipment apply</p> <p>a) to the main switch of each independent power circuit (e.g. machine, heating system) of the escalator or moving walk and dependent circuits, or</p> <p>b) to the switch for the lighting circuit of the escalator or moving walk and dependent circuits.</p> <p>The escalator or moving walk shall be considered as a whole, in the same way as a machine with its incorporated apparatus.</p>	—	—
<p>5.11.1.2.2 The electricity supply to the input terminals of the switches referred to in 5.11.1.2.1 and the electricity supply to the lighting of the machinery spaces, driving, and return stations are not laid down by this standard.</p>	—	—

EN 115-1 (Europe)	A17.1/B44 (North America)	Japanese codes
<p>5.11.1.2.3 The electromagnetic compatibility shall comply with the requirements of EN 12015 and EN 12016.</p>	<p>6.1.7.4.3/6.2.7.4.3 Control equipment shall be tested in accordance with the testing requirements of EN 12016 by exposing it to interference levels at the test values specified for “safety circuits”. The interference shall not cause any of the conditions described in 6.1.6.10.1 (a) through (f)/6.2.6.9.1 (a) through (e). If enclosure doors or suppression equipment must remain installed to meet the above requirements, warning signs to that effect shall be posted on the control equipment..</p>	<p>—</p>
<p>5.11.1.3 Protection against direct contact For protection against direct contact, the requirements of EN 60204-1:2006, 6.2 shall apply.</p>	<p>6.1.7.4.1 All electrical equipment and wiring shall conform to NFPA 70 or CSA-C22.1, whichever is applicable (<i>ref. NFPA, Rule 620.4 and 620.71</i>).</p>	<p>—</p>
<p>5.11.1.4 Insulation resistance tests For resistance of the insulation between conductors and between conductors and the earth, EN 60204-1:2006, 18.3 shall apply.</p>	<p>6.1.7.4.1 All electrical equipment and wiring shall conform to NFPA 70 or CSA-C22.1, whichever is applicable (<i>ref. NFPA, Rule 620.11(d)</i>).</p>	<p>JIS A 4302-2006 Inspection standard of elevator, escalator, and dumbwaiter 4.4.1 Inspection to be carried out in machinery room (1) The insulation resistance shall satisfy the provisions of Table 10 as applicable to the respective purpose of the circuit below. However, the insulation resistance may be inspected on each circuit which can be separated by switches or overcurrent circuit breakers.</p>
<p>5.11.1.5 Voltage limit for control and safety circuit For control and safety circuits, the value in direct current or the r.m.s. value in alternating current between conductors or between conductors and earth shall not exceed 250 V.</p>	<p>6.1.7.4.1 All electrical equipment and wiring shall conform to NFPA 70 or CSA-C22.1, whichever is applicable (<i>ref. NFPA, Rule 620.3</i>).</p>	<p>Remarks: 1. The insulation resistance shall be calculated in accordance with remarks to 4.2.1(2). 2. The service voltage of the circuit for the instantaneous-start fluorescent lamp (so-called slim-line lamp) used for lighting the sides of escalator, etc. shall be the primary (low voltage side) voltage.</p>
<p>5.11.1.6 Conductor for neutral and earth-continuity The earth-continuity conductor shall be in accordance with EN 60204-1: 2006, Clause 8.</p>	<p>J. Grounding NFPA 620-84. Escalators, Moving Walks, Wheelchair Lifts, and Stairway Chair Lifts. Escalators, moving walks, wheelchair lifts, and stairway chair lifts shall comply with Article 250.</p>	<p>EUIL-MO-1997; 13, 18 JEAC 8001-2005; 140-3, 140-15</p>

EN 115-1 (Europe)	A17.1/B44 (North America)	Japanese codes
<p>5.11.2 Contactors, relay contactors, components of electrical safety circuits</p> <p>5.11.2.1 Contactors and relay contactors</p> <p>5.11.2.1.1 To stop the driving machine (see 5.12.1.2.4), the main contactors shall belong to the following categories as defined in EN 60947-4-1:</p> <p>a) AC-3 for contactors of alternating current motors; b) DC-3 for contactors of direct current machines.</p>	—	<p>JIS C 8325-1983; AC electromagnetic switches.</p>
<p>5.11.2.1.2 Relay contactors (see 5.12.1.2.4) shall belong to the following categories as defined in EN 60947-5-1:</p> <p>a) AC-15 for contactors in alternating current control circuits; b) DC-13 for contactors in direct current control circuits.</p>	—	—
<p>5.11.2.1.3 For both, the main contactors (see 5.11.2.1.1) and the relay contactors (see 5.11.2.1.2), it is permissible to assume in the measures taken to comply with 5.12.1.1.2 that</p> <p>a) if one of the break contacts (normally closed) is closed, all the make contacts are open, and b) if one of the make contacts (normally open) is closed, all the break contacts are open.</p>	—	—
<p>5.11.2.2 Components of fail safe circuits</p> <p>5.11.2.2.1 When devices according to 5.11.2.1.2 are used as relays in a fail safe circuit, the assumptions of 5.11.2.1.3 also apply.</p>	—	—
<p>5.11.2.2.2 If the relays used, are such that the break and make contacts are never closed simultaneously for any position of the armature, the possibility of partial attraction of the armature shall not be taken into account [see 14.1.1.1 f)].</p>	—	—

EN 115-1 (Europe)	A17.1/B44 (North America)	Japanese codes
<p>5.11.2.2.3 Devices connected after electric safety devices shall meet the requirements of 5.12.1.2.2.2 with regard to the creep distances and air gaps (not with regard to the separation distances).</p> <p>This requirement does not apply to the devices mentioned in 5.11.2.1.</p>	—	<p>JIS C 8325-1983; AC electromagnetic switches.</p>
<p>5.11.3 Protection of motors</p> <p>5.11.3.1 Motors directly connected to the mains shall be protected against short-circuiting.</p>	—	<p>EUIL-MO-1997 [Facilities of overload protection device of motor] (Ministerial Ordinance Article 65) Article 169 For a motor equipped indoors in the event of an over-current, a device which automatically obstructs an over-current that may cause a motor to burn or an alarm device shall be provided. The article, however, shall not be applicable to any of the following cases.</p>
<p>5.11.3.2 Motors directly connected to the mains shall be protected against overload by means of automatic circuit breakers with manual reset (except as provided for in 5.11.3.3) which shall cut off the supply to the motor in all live conductors (see EN 60947-4-1).</p>	—	<p>1. A case of the motor equipped where the person in charge can always watch the motor during operation.</p> <p>2. A case of the motor that has no risk to carry an over-current which may cause the motor to burn because of the motor structures or nature of a motor load.</p> <p>3. A case of a single-phase motor where a rated current of the over-current breaker furnished on the line of the power source is not exceeding 15 A (20 A for a moulded-type circuit breaker).</p>
<p>5.11.3.3 When the detection of overload operates on the basis of temperature increase in the windings of the motor, the circuit breaker is permitted to close automatically after sufficient cooling down has taken place, however, it shall only be possible to re-start the escalator or passenger conveyor under the conditions of 14.2.1.</p>	—	<p>JEAC 8001-2005 Rule 3705-5 Facilities for overload protection device of motors and the like</p> <p>1. An overload protection device for a motor, such as a fuse, a moulded-case circuit-breaker, a thermal relay, an induction type relay, a static type relay, or the similar device for motor protection which is effective in preventing the motor from burning or an overload alarming device shall be provided. The article, however, shall not be applicable to any of the following cases (EUIL-MO 184).</p>

EN 115-1 (Europe)	A17.1/B44 (North America)	Japanese codes
<p>5.11.3.4 The provisions of 5.11.3.2 and 5.11.3.3 apply to each winding if the motor has windings supplied by different circuits.</p>	<p>—</p>	<p>1) The motor itself has an effective preventive device against overload burning.</p> <p>2) Even in case of a start failure, there is no risk of burning the motor due to a high impedance of a motor winding.</p> <p>NOTE An a. c. motor not exceeding 35 W or so generally corresponds to the above.</p> <p>3) The person in charge always operates the motor like a general machine tool, a hoist, or the like.</p> <p>4) There is no risk of overloading the motor because of a nature of a load.</p> <p>5) A single-phase motor is supplied from the branched circuits of 15 A (20 A for a moulded-case circuit-breaker).</p> <p>6) An output of the motor is not exceeding 0,2 kW.</p>
<p>5.11.3.5 When the escalator or passenger conveyor driving motors are supplied by d.c. generators driven by motors, the generator driving motors shall also be protected against overload.</p>	<p>—</p>	<p>NOTE 1 A fuse for the motor, which corresponds with the rated output or the rated current of the motor, shall be used.</p> <p>NOTE 2 A fuse for the motor shall be provided at every pole as a general rule, but the fuse for the branched over-current breaker shown in Table 3-3 may be used for the grounding side.</p> <p>NOTE 3 The overload protection device for the motor shall be located as closely as possible to the motor.</p> <p>2. For a motor which may fail to function or be damaged remarkably due to a phase failure of the power source, a protection device (an alarm device acceptable if no hitch) against the phase failure shall be provided for prevention of burning caused by the phase failure as a rule.</p>

EN 115-1 (Europe)	A17.1/B44 (North America)	Japanese codes
<p>5.11.4 Main switches</p> <p>5.11.4.1 In the vicinity of the machine, or in the return stations, or in the vicinity of the control devices, there shall be a main switch capable of breaking the supply to the motor, the brake releasing device, and to the control circuit in the live conductors.</p> <p>This switch shall not cut the supply to the socket outlets or to the lighting circuits necessary for inspection and maintenance (see 5.8.3).</p> <p>When separate supplies are provided for auxiliary equipment such as heating, balustrade lighting and comb lighting it shall be possible to switch them off independently. The corresponding switches shall be located close to the main switch and be marked unambiguously.</p>	—	<p>JIS A 4302-1992 Inspection standard of elevator, escalator, and dumbwaiter</p> <p>4.2.1 Inspection to be carried out in machinery room.</p> <p>(2) Incoming panel, main switch, control board, conduit tube, and wiring</p> <p>(a) The incoming panel and main switch shall, as a rule, be located near the machinery room entrance and shall be capable of being safely and easily operated.</p> <p>(b) The control board and other control equipment shall be installed firmly, and provided with measures to prevent displacement and tumbling due to vibration of earthquake, etc.</p> <p>(c) The operation of contact points of every switch on the board shall be good.</p>
<p>5.11.4.2 The main switches as defined in 5.11.4.1 shall be capable of being locked or, otherwise, secured in the “isolated” position with the use of a padlock or equivalent to ensure no inadvertent operation by others (see EN 60204-1:2006, 5.3.3). The control mechanism of the main switch shall be easily and rapidly accessible after opening of the doors or trap doors.</p>	—	<p>(d) The insulation resistance of each circuit shall satisfy the requirements of Table 1. The insulation resistance shall be capable of being inspected on each circuit divisible by switches or overcurrent breakers.</p>
<p>5.11.4.3 Main switches shall be capable of interrupting the highest current involved in normal operating conditions of the escalator or moving walk. They shall comply with the requirements of EN 60204-1:2006, Clause 5.</p>	—	
<p>5.11.4.4 Where the main switches for several escalators or moving walks are positioned together, it shall be possible to easily identify which escalator or moving walk they refer.</p>	—	
<p>5.11.5 Electrical wiring</p> <p>5.11.5.1 General</p> <p>5.11.5.1.1 Cables shall be selected from those standardized by CENELEC and of a quality at least equivalent to that defined by below mentioned standards of the CENELEC HD 21 and HD 22 series.</p>	—	<p>JIS A 4302-1992 Inspection standard of elevator, escalator, and dumbwaiter</p> <p>4.4.1 Inspection to be carried out in machinery room.</p> <p>(1) The insulation resistance shall satisfy the provisions of Table 10, as applicable to the respective</p>

EN 115-1 (Europe)	A17.1/B44 (North America)	Japanese codes
<p>5.11.5.1.2 Conductors such as those in conformity with CENELEC HD 21.3 S3, part 2 (HO7V-U and HO7V-R), part 3 (HO7V-K), part 4 (HO5V-U), and part 5 (HO5V-K) are permitted only in conduits, ducting, or similar fittings ensuring equivalent protection. When deviating from CENELEC HD 21.3 S3, the nominal cross-sectional area of the conductors shall be not less than 0,75 mm².</p>	—	<p>purpose of circuit below. However, the insulation resistance may be inspected on each circuit which can be separated by switches or over-current circuit breakers.</p> <p>Remarks:</p> <p>1. The insulation resistance shall be calculated in accordance with remarks to 4.2.1 (2).</p> <p>2. The service voltage of the circuit for the instantaneous-start fluorescent lamp (so- slim-line lamp) used for lighting the sides of escalator, etc. shall be the primary (low voltage side) voltage.</p> <p>JIS C 3301-1987 Rubber insulated flexible cords JIS C 3306-1987 Polyvinyl chloride insulated flexible cords</p>
<p>5.11.5.1.3 Rigid cables, such as those in conformity with part 2 of CENELEC HD 21.4 S2, are permitted only in visible mountings fixed to the walls or in conduits, ducting, or similar fittings.</p>	—	<p>JIS C 3307-1993 V polyvinyl chloride insulated wires</p> <p>JIS C 3316-1993 Polyvinyl chloride insulated wires for electrical apparatus</p>
<p>5.11.5.1.4 Ordinary flexible cables, such as those in conformity with part 3 (HO5RR-F) of CENELEC HD 22.4 S2 and part 5 (HO5VV-F) of CENELEC HD 21.5 S2, are permitted only in conduits, ducting or similar fittings ensuring equivalent protection.</p> <p>Flexible cables with a thick sheath such as those in conformity with part 5 of CENELEC HD 22.4 S2 are permitted to be installed rigidly in the conditions defined in 13.5.1.2 and for connection to a movable appliance or if they are subject to vibrations.</p> <p>NOTE The requirements of 5.11.5.1.2 and 5.11.5.1.4 replace those in the guide to use appearing in HD 516 S2/A1.</p>	—	<p>JIS C 3317-1987 600V grade heat-resistant polyvinyl chloride insulated wires</p> <p>JIS C 3327-1993 600V rubber insulated flexible cables</p> <p>JIS C 3342-1993 600V polyvinyl chloride insulated and sheathed cables</p> <p>JIS C 3401-1992 Control cables</p> <p>JIS C 3408-1987 Travelling cables for elevators</p> <p>JIS C 3652-1987 Installation methods of power flat conductor cables</p>

EN 115-1 (Europe)	A17.1/B44 (North America)	Japanese codes
<p>5.11.5.1.5 The requirements of 5.11.5.1.2, 5.11.5.1.3 and 5.11.5.1.4 need not apply to the wiring of control or distribution devices in control cabinets or on control panels.</p> <p>a) Either between different pieces of electrical equipment, or b) between these pieces of equipment and the connection terminals.</p> <p>In these instances, the requirements of EN 60439-1:1999, 7.8 apply.</p>	—	<p>EUIL-MO-1997</p> <p>[Facilities of low voltage indoor wiring for elevators, dumbwaiters, and the like]</p> <p>(Ministerial Ordinance Article 57)</p> <p>Article 200</p> <p>For low voltage indoor wiring, low voltage travelling cables, and low voltage indoor wiring that directly connects the above which are installed in hoistways of elevators,</p>
<p>5.11.5.2 Cross-sectional area of conductors</p> <p>In order to provide mechanical strength, the cross-sectional area of the conductors of safety circuits shall be not less than 0,75 mm².</p>	—	<p>dumbwaiters, and the like, and whose working voltage is not exceeding 300 V, the cables for elevators corresponding to the following may be used:</p> <p>1. their structures shall conform to</p>
<p>5.11.5.3 Method of installation</p> <p>5.11.5.3.1 The electric installation shall be provided with the indications necessary to make it easy to understand.</p>	—	<p>the requirements of the item 4, "Materials, structures, and processing methods: of the Japanese Industrial Standard JIS C 3408 (1993) "Travelling cables for</p>

EN 115-1 (Europe)	A17.1/B44 (North America)	Japanese codes
(5.11.5.3.1.1)	—	<p>elevators”.</p> <p>2. Their finished products shall conform to the requirements of the item 3, “Characteristics“ when they are tested by the item 6, “Testing methods“ of the Japanese Industrial Standard JIS C 3408 (1993) “Travelling cables for elevators“.</p> <p>EUIL-MO-1997</p> <p>[Works for indoor discharge lamps (part 2)] (Ministerial Ordinance Article 10, 11, 56, and 57)</p> <p>Article 207</p> <p>10 When electrical wiring of lighting circuits (applicable to only wiring installed in an enclosure where possible for an inspection) installed in a dry place within escalators is enclosed in soft vinyl tubes, the wiring shall conform to the following:</p> <p>a) fluorescent lamp electrical wires shall be used for electrical wires and every wire shall be installed in an independent soft vinyl tube (related to Ministerial Ordinance Article 57);</p> <p>b) soft vinyl tubes shall conform to the requirements of the item 6, “Testing“ of the Japanese Industrial Standard JIS C 2415 (1994) “Extruded tubes for electrical insulation“;</p> <p>c) any joint of electrical wires except the joints with lead wires of the ballasts or those of the lamp sockets for discharge lamps shall not be made;</p> <p>d) metal structures which may touch electrical wires shall be grounded by the Class D grounding (related to Ministerial Ordinance Article 10 and Article 11).</p>

EN 115-1 (Europe)	A17.1/B44 (North America)	Japanese codes
<p>5.11.5.3.2 If, after the opening of the main switch or switches of the escalator or passenger conveyor, some connection terminals remain live, they shall be clearly separated from terminals which are not live if the voltage exceeds 50 V, they shall be suitably marked.</p> <p>In these instances, the requirements of EN 60204-1:2006, 53.5 and 16.2 apply.</p>	—	<p>MOC-N (No.1424-2000)</p> <p>1(2)(c) The door covering the opening surrounding the escalator is closing.</p> <p>JEAS-A407 Standard for interlocking suspension of escalators with fireproof shutters</p> <p>2. Description</p> <p>2.2 Contacts for interlocking (refer to Figure 2 and Figure 3).</p> <p>A contact for interlocking to be provided at the shutter shall be "b" contact (contact to be opened before the closing shutter comes down to a height of 1,8 m above floor level) of DC 125V 0.2A (AC 250V 1A) in rating and number of contacts shall be same as number of escalators necessary to be interlocked.</p>
<p>5.11.5.3.3 In order to ensure continuity of mechanical protection, the protective enclosures of cables shall enter the casings of switches and appliances or shall have proper glands at their ends.</p>	—	<p>JEAC 8001-2005</p> <p>Rule 3220-8 Wiring of lighting circuits in escalators</p> <p>All electrical wiring (applicable to only wiring installed in an enclosure where it is possible for an inspection) of lighting circuits in escalators which are installed in a dry place shall conform to the following (EUIL-MO 222):</p> <p>1) fluorescent lamp electrical wires shall be used for electrical wires and every wire shall be installed in an independent soft vinyl pipe;</p> <p>NOTE Concerning the soft vinyl pipe, the pipes conforming to the requirements of JIS C 2410 (P.V.C. tubing for electrical insulation) shall be used.</p>
<p>5.11.5.4 Connectors</p> <p>Connectors and devices of the plug-in type which are safety related and which can be extracted without the use of a tool shall be designed in such a way that it is impossible to re-insert them incorrectly.</p>	—	<p>JEAC 8001-2005</p> <p>Rule 3220-8 Wiring of lighting circuits in escalators</p> <p>All electrical wiring (applicable to only wiring installed in an enclosure where it is possible for an inspection) of lighting circuits in escalators which are installed in a dry place shall conform to the following (EUIL-MO 222):</p> <p>1) fluorescent lamp electrical wires shall be used for electrical wires and every wire shall be installed in an independent soft vinyl pipe;</p> <p>NOTE Concerning the soft vinyl pipe, the pipes conforming to the requirements of JIS C 2410 (P.V.C. tubing for electrical insulation) shall be used.</p>

EN 115-1 (Europe)	A17.1/B44 (North America)	Japanese codes												
		<p>2) any joint of electrical wires except the joints with lead wires of the ballast or those of the lamp-sockets for discharge lamps shall not be made;</p> <p>3) metal structures which may touch electrical wires shall be grounded by the Class 3 grounding.</p> <p>JEAC 8001-2005</p> <p>Rule 3305-14 Escalators</p> <p>All electrical wiring shall conform to the following: (EUIL-MO 215).</p> <p>6) Sizes of electrical wires and travelling cables installed in hoistways and travelling body shall conform to the sizes listed in Table 3-17.</p> <p>Table 3305-9 — Sizes of electrical wires and travelling cables for elevators and the like</p> <table border="1" data-bbox="1129 976 1437 1305"> <thead> <tr> <th>Type of wire</th> <th>Conductor size</th> </tr> </thead> <tbody> <tr> <td>Insulated wire, solid</td> <td>≥ 1,2 mm²</td> </tr> <tr> <td>Insulated wire, stranded</td> <td>≥ 1,4 mm²</td> </tr> <tr> <td>Cable, solid wire</td> <td>≥ 0,8 mm²</td> </tr> <tr> <td>Cable, stranded wire</td> <td>≥ 0,75 mm²</td> </tr> <tr> <td>Travelling cable</td> <td>≥ 0,75 mm²</td> </tr> </tbody> </table>	Type of wire	Conductor size	Insulated wire, solid	≥ 1,2 mm ²	Insulated wire, stranded	≥ 1,4 mm ²	Cable, solid wire	≥ 0,8 mm ²	Cable, stranded wire	≥ 0,75 mm ²	Travelling cable	≥ 0,75 mm ²
Type of wire	Conductor size													
Insulated wire, solid	≥ 1,2 mm ²													
Insulated wire, stranded	≥ 1,4 mm ²													
Cable, solid wire	≥ 0,8 mm ²													
Cable, stranded wire	≥ 0,75 mm ²													
Travelling cable	≥ 0,75 mm ²													

EN 115-1 (Europe)	A17.1/B44 (North America)	Japanese codes
		<p>Reference 1: Conductors with a size not less than 0,75 mm² may be used only for short runs connecting terminating piping boxes to mechanical apparatus for the wires with the mark of “*”.</p> <p>Reference 2: Solid wires with a diameter not less than 0,8 mm and less than 1,6 mm or stranded wires with a cross section not less than 0,75 mm² and less than 2 mm² with the mark of “**” may be used only for control or signal circuits when a device breaking an over-current and disconnecting it automatically from the electrical circuits in the event of an over-current.</p> <p>Reference 3: Concerning conductor sizes of travelling cables, three kinds of 0,75 mm², 1,4 mm², and 2,0 mm² are prescribed by the Japanese Industrial Standard JIS C 3408 “Travelling cables for elevators”.</p>
		<p>9) An over-current breaker shall be provided for a branched circuit (e.g. circuits for a micro motor, a cam motor, a door motor, lamps within hoistways, or the like control circuits or the similar circuits). Provided, for the circuits such as magnetic brake circuits where an over-current breaker is not recommendable to be provided, the above may be excluded.</p> <p>NOTE Concerning installation of an over-current breaker, see Rule 150-9 “Rated current of an over-current breaker for protection of electrical wires”.</p> <p>10) For electrical wires connecting to resistors or the like whose temperature rise is not less than 60 °C, electrical wires of heat resistance property shall be used. Provided, insulated wires may be used, if a covering of a portion having excessive temperature rise is removed and the portion is covered by an insulator of heat resistance property or the portion is treated by inserting miniature porcelain bushings or the like.</p>

EN 115-1 (Europe)	A17.1/B44 (North America)	Japanese codes
		<p>JEAC 8001-1995</p> <p>Rule 310-14 Escalators</p> <p>All electrical wiring installed in escalators shall conform to the following:</p> <p>1) All electrical wiring in escalators shall be installed by metallic conduit wiring, synthetic resin tube wiring, metal raceway wiring, or cable wiring (excluding lead-covered cables of rubber insulation) except the cases corresponding to the following:</p> <p>a) a case where the wiring for short runs connecting the junction box to every mechanical apparatus is installed by flexible metal conduit tube wiring. Provided RB electrical wires (those of rubber insulation) shall not be used where electrical wires could be possibly damaged by oil;</p>
		<p>b) a case where wiring is installed by using chloroprene or vinyl armor sheathed cables for short runs connecting the junction box to every mechanical apparatus where electrical wires are not feared to be possibly damaged mechanically.</p> <p>2) All electrical wiring shall be securely fastened to stationary structures so as not to be damaged by a possible contact to a movable structure.</p> <p>3) Sizes of electrical wires for wiring shall conform to the requirements of the item 6) of Rule 310-13 "Elevators and dumbwaiters".</p> <p>4) An over-current breaker shall be provided for circuits branched from the main motor circuits according to the requirements of the item 9) of Rule 310-13 "Elevators and dumbwaiters".</p>

EN 115-1 (Europe)	A17.1/B44 (North America)	Japanese codes
<p>5.11.6 Connecting terminals Connection terminals, an accidental interconnection of which could lead to a dangerous malfunction of the escalator or moving walk, shall be clearly separated.</p>	—	—
<p>5.11.7 Protection against electrostatic loading Means to discharge electrostatic loading shall be provided (e.g. brushes).</p>	—	—
<p>5.12 Protection against electrical faults - controls 5.12.1 Protection against electrical faults 5.12.1.1 General 5.12.1.1.1 Any single fault listed in 5.12.1.1.2 in the electric equipment of an escalator or moving walk, if it cannot be excluded under conditions described in 5.12.1.1.3 and/or Annex B, shall not, on its own, be the cause of a dangerous situation of the escalator or moving walk.</p>	<p><i>These items contained in EN 115-1 Clause 5.12, except as specifically noted, are not addressed in A17.1/B44, Part VIII. Some of them will be a part of the next edition of the code and some are currently covered in the National Electrical Code, ANSI/NFPA 70.</i></p> <p>6.1.6.10.1/6.2.6.9.1 The occurrence of a single ground or the failure of any single magnetically operated switch, contactor, or relay, or any single solid-state device, or a software system failure, shall not</p> <p>(a) permit the escalator/moving</p>	<p>See JEAC 8001-2005 and JIS A 4302-2006.</p>
—	<p>walk to start,</p> <p>(b) render ineffective any electrical protective device required by 6.1.6.3/6.2.6.3,</p> <p>(c) render ineffective the handrail speed-monitoring device required by 6.1.6.4/6.2.6.4,</p> <p>(d) render ineffective the missing step/pallet device required by 6.1.6.5/6.2.6.5, and</p> <p>(e)/(f) permit the escalator/moving walk to revert to normal operation when on inspection operation (see 6.1.6.2.2/6.2.6.2.2).</p> <p>NOTE [6.1.6.10.1 (b) through (e)/6.2.6.9.1 (b) through (d)]: Requirements only apply to the circuits in which the devices are used and not the devices themselves.</p> <p>6.1.6.10.1/6.2.6.9.1 (e)/ - render ineffective the missing dynamic skirt device required by 6.1.6.5</p>	—

EN 115-1 (Europe)	A17.1/B44 (North America)	Japanese codes
<p>5.12.1.1.2 The following faults shall be envisaged:</p> <p>d) fault to earth of a circuit; f) non-attraction or incomplete attraction of the moving armature of a contactor or relay; g) non-separation of the moving armature of a contactor or relay.</p>	<p>6.1.6.10.2/6.2.6.9.2 Methods used to satisfy 6.1.6.10.1/6.2.6.9.1 using software systems are permitted provided that a non-software-controlled means is also used to remove power from the driving-machine motor and brake.</p> <p>6.1.6.10.3/6.2.6.9.3 Methods used in the control and operating circuits to satisfy the requirements of 6.1.6.10.1/6.2.6.9.1 shall be checked prior to each start of the escalator/moving walk. When a single ground or failure as specified in 6.1.6.10.1/6.2.6.9.1 occurs, the escalator/moving walk shall not be permitted to restart.</p>	—
<p>a) absence of voltage; b) voltage drop; c) loss of continuity of a conductor; e) short circuit or open circuit, change of value, or function in an electrical component such as resistor, capacitor, transistor, lamp; h) non-opening of a contact; i) non-closing of a contact; j) phase reversal.</p>		—
<p>5.12.1.1.3 The non-opening of a contact need not be considered in the case of safety switches conforming to 5.12.1.2.2.</p>		—
<p>5.12.1.1.4 The fault to earth of a circuit in which there is an electric safety device shall cause the immediate stopping of the driving machine [see Table 6 p)].</p>	<p>6.1.6.11 Electrically powered safety devices. If the handrail speed monitoring device required by 6.1.6.4, the missing step or missing skirt device required by 6.1.6.5, or any electrical protective device required by 6.1.6.3 requires electrical power for its functioning</p> <p>(a) a loss of electrical power to the device shall cause power to be removed from the escalator driving machine motor and brake;</p> <p>(b) the occurrence of a single ground or the failure of any single magnetically operated switch, contactor, or relay, or any single solid-state device, or a software system failure shall not render the missing step or missing dynamic skirt devices or handrail speed monitoring device or electrical protective device inoperative;</p> <p>(c) when a single ground or failure as described in 6.1.6.11(b) occurs, the escalator shall not be permitted to restart.</p>	—

EN 115-1 (Europe)	A17.1/B44 (North America)	Japanese codes
	<p>6.1.6.15 Contactors and relays for use in critical operating circuits. Where electromechanical contactors or relays are provided to fulfill the requirements of 6.1.6.10.1 through 6.1.6.10.4, they shall be considered to be used in critical operating circuits. If contact(s) on these electromechanical contactors or relays are used for monitoring purposes, they shall be prevented from changing state if the contact(s) utilized in a critical operating circuit fail to open in the intended manner.</p> <p>The monitoring contact(s) shall be positively actuated and shall not be solely dependent upon springs.</p> <p>6.2.6.10 Electrically powered safety devices. If the handrail-speed monitoring device required by 6.2.6.4, the missing pallet device required by 6.2.6.5 or any electrical protective device required by 6.2.6.3 requires electrical power for its functioning (a) a loss of electrical power to the device shall cause power to be removed from the moving walk driving machine motor and brake, (b) the occurrence of a single ground or the failure of any single magnetically operated switch, contactor, or relay, or any single solid-state device, or a software system failure shall not render the missing pallet device or handrail speed monitoring device or electrical protective device inoperative, and (c) when a single ground or failure as described in 6.2.6.10.2 occurs, the moving walk shall not be permitted to restart.</p> <p>6.2.6.14 Contactors and relays for use in critical operating circuits. Where electromechanical contactors or relays are provided to fulfill the requirements of 6.2.6.9.1 through 6.2.6.9.4, they shall be considered to be used in critical operating circuits. If the contact(s) on these electromechanical contactors or relays is used for monitoring purposes, it shall be prevented from changing state if the contact(s) utilized in a critical operating circuit fails to open in the intended manner. The monitoring contact(s) shall be positively actuated and shall not be solely dependent upon springs.</p>	

EN 115-1 (Europe)	A17.1/B44 (North America)	Japanese codes
<p>5.12.1.2 Electric safety devices</p> <p>5.12.1.2.1 General requirements</p> <p>5.12.1.2.1.1 The electric safety device for the events listed in Table 6 shall prevent the driving machine from starting or cause the immediate stopping of the driving machine according to 5.12.1.2.4 and consists of</p> <p>a) either one or more safety switches satisfying 5.12.1.2.2 directly disconnecting the supply to the contactors or their relay contactors, or</p> <p>b) fail safe circuits satisfying 5.12.1.2.3 consisting of</p> <p>1) either one or more safety contacts satisfying 5.12.1.2.2 not directly disconnecting the supply to the contactors or their relay contactors,</p> <p>2) contacts not satisfying the requirements of 14.1.2.2, or</p> <p>3) other components in accordance with the requirements of Annex B.</p>	<p>6.1.6.10.4/6.2.6.9.4 Escalators/moving walks with driving-machine motors employing static control shall conform to the following:</p> <p>(a) two devices shall be provided to remove power from the driving-machine motor. At least one device shall be an electromechanical contactor;</p> <p>(1) the contactor shall be arranged to open each time the escalator/moving walk stops;</p> <p>(2) the contactor shall cause the removal of power from the driving-machine brake in accordance with 6.1.6.3.4/6.2.6.3.4;</p> <p>(b) an additional contactor shall be provided to also open the driving-machine brake circuit. This contactor is not required to have contacts in the driving-machine motor circuit;</p> <p>(c) the electrical protective devices required by 6.1.6.3/6.2.6.3 shall control the solid-state device and both contactors;</p> <p>(d) after each stop of the escalator/moving walk, the escalator/moving walk shall not respond to a signal to start unless both contactors [see 6.1.6.10.4 (a) and (b)/6.2.6.9.4 (a) and (b)] are in the de-energized position.</p>	—
<p>c) programmable electronic systems in safety related applications in accordance with 5.12.1.2.6 directly disconnecting the supply to the contactors or their relay contactors.</p>	—	—
<p>5.12.1.2.1.2 No electric equipment shall be connected in parallel with an electric safety device with the exception of the following:</p> <p>a) electric safety devices in case of inspection mode (5.12.2.5);</p> <p>b) connections to different points of the safety circuit for information about the status of electric safety devices, the devices used for that purpose shall fulfil the requirements of Annex B.</p>	No equivalent requirement	—
<p>5.12.1.2.1.3 The effects of internal or external inductance or capacitance shall not cause failures of fail safe circuits.</p>	<p>6.1.6.12/6.2.6.11 Installation of capacitors or other devices to make electrical protective devices ineffective. The installation of</p>	—

EN 115-1 (Europe)	A17.1/B44 (North America)	Japanese codes
<p>5.12.1.2.1.4 An output signal emanating from a fail safe circuit shall not be altered by an extraneous signal emanating from another electric device placed further down the same circuit, which would cause a dangerous condition to result.</p>	<p>capacitors or other devices, the operation or failure of which will cause an unsafe operation of the escalator/moving walk is prohibited. No permanent device shall be installed, except as provided for in this code which will make any required electrical protective device ineffective (see also 6.1.6.3.4).</p>	<p>—</p>
<p><i>covered by requirements in Annex B</i></p>		<p>—</p>
<p><i>covered by 5.12.1.2.1.1</i></p>		<p>—</p>
<p>5.12.1.2.1.5 The construction and arrangement of the internal power supply units shall be such as to prevent the appearance of false signals at the outputs of electric safety devices due to the effects of switching. In particular, voltage peaks arising from the operation of the escalator or moving walk or other equipment on the network shall not create inadmissible disturbances in electronic components (noise, immunity) in compliance with EN 12015 and EN 12016.</p>	<p>6.1.7.4.3/6.2.7.4.3 Control equipment shall be tested in accordance with the testing requirements of EN 12016 by exposing it to interference levels at the test values specified for “safety circuits”. The interference shall not cause any of the conditions described in 6.1.6.10.1 (a) through (f). If enclosure doors or suppression equipment must remain installed to meet the above requirements, warning signs to that effect shall be posted on the control equipment.</p>	<p>—</p>
<p>5.12.1.2.2 Safety switches</p> <p>5.12.1.2.2.1 The operation of a safety contact shall be by positive mechanical separation of the circuit breaking devices. This positive mechanical separation shall even occur if the contacts are welded together.</p> <p>Positive mechanical separation is achieved when all contacts are brought to their open position in such a way that for a significant part of the travel there are no resilient elements (e.g. springs) between the moving contacts and the part of the actuator to which the actuating force is applied.</p> <p>The design shall be such as to minimize the risk of a short-circuit resulting from a faulty component.</p>	<p>The items contained in EN 115-1 Clause 5.12.1.2.2 are not addressed in A17.1/B44, Part VIII. Some of them will be a part of the next edition of the code and some are currently covered in the National Electrical Code, ANSI/NFPA 70.</p>	<p>—</p>

EN 115-1 (Europe)	A17.1/B44 (North America)	Japanese codes
<p>5.12.1.2.2.2 The safety switch shall be provided for a rated insulation voltage of 250 V if the enclosure provides a degree of protection of at least IP4X (in accordance with EN 60529) or 500 V if the degree of protection of the enclosure is less than IP4X.</p> <p>Safety switches shall belong to the following categories as defined in EN 60947-5-1.</p> <p>a) AC-15 for safety contacts in alternating current circuits. b) DC-13 for safety contacts in direct current circuits.</p>		—
<p>5.12.1.2.2.3 If the protective enclosure is not at least of type IP4X, the air gaps shall be at least 3 mm and creep distances at least 4 mm.</p> <p>After separation the distances for contacts shall be at least 4 mm.</p>		—
<p>5.12.1.2.2.4 In the case of multiple breaks, the individual distances for breaking contacts shall be at least 2 mm after separation.</p>		—
<p>5.12.1.2.2.5 Debris from the conductive material shall not lead to short-circuiting of contacts.</p>		—
<p>5.12.1.2.3 Fail safe circuits</p> <p>5.12.1.2.3.1 Anyone of the faults envisaged in 5.12.1.1. shall not, on its own, be the cause of a dangerous situation.</p>		—
<p>5.12.1.2.3.2 Furthermore, the following conditions apply for the faults envisaged in 5.12.1.1:</p> <p>If one fault combined with a second fault can lead to a dangerous situation, the escalator or moving walk shall be stopped by the time the next operating sequence takes place in which the faulty element should participate.</p> <p>The possibility of the second fault leading to a dangerous situation before the escalator or moving walk has been stopped by the sequence mentioned is not considered.</p>		—

EN 115-1 (Europe)	A17.1/B44 (North America)	Japanese codes
<p>If the malfunction of the component which has caused the first fault cannot be detected by a change of state, appropriate measures shall ensure that the fault is detected and movement prevented at the latest when the escalator or moving walk is restarted according to 5.12.2.4.</p> <p>The mean time between failures (MTBF) of the fail safe circuit shall be at least 2,5 years. This time was determined under the assumption that within a period of three months each escalator or each moving walk is restarted according to 5.12.2.4 at least once and, thus, is subject to a change of state.</p>		
<p>5.12.1.2.3.3 If two faults combined with a third fault can lead to a dangerous situation, the escalator or moving walk shall be stopped by the time the next operating sequence takes place in which one of the faulty elements should participate.</p> <p>The possibility of the third fault leading to a dangerous situation before the escalator or moving walk has been stopped by the sequence mentioned is not considered.</p> <p>If the malfunction of the components which have caused the two faults cannot be detected by a change of state, appropriate measures shall ensure that the faults are detected and movement is prevented at the latest when the escalator or moving walk is restarted according to 5.12.2.4.</p> <p>The mean time between failures (MTBF) of the fail safe circuit shall be at least 2,5 years. This time was determined under the assumption that within a period of three months each escalator or each moving walk is restarted according to 5.12.2.4 at least once and, thus, is subject to a change of state.</p>		<p>—</p>

EN 115-1 (Europe)	A17.1/B44 (North America)	Japanese codes
<p>5.12.1.2.3.4 A combination of more than three faults can be disregarded if</p> <p>a) the fail safe circuit is built-up of at least two channels and their equal status is monitored by a control circuit. The control circuit shall be checked prior to a restart of the escalator or moving walk according to 5.12.2.4 (see also Annex C), or</p> <p>b) the fail safe circuit is built-up of at least three channels and their equal status is monitored by a control circuit.</p> <p>If the requirements of a) or b) are not fulfilled, it is not permitted to interrupt the failure analysis, but it shall be continued analogous to 5.12.1.2.3.3.</p>		—
<p>5.12.1.2.4 Operation of electric safety devices</p> <p>When operated, an electrical safety device shall prevent the setting in motion of the driving machine or immediately initiate its stopping. The operational brake shall be activated.</p>		<p>BSLJ-EO; Article 129-12</p> <p>4. Escalators shall be provided with the emergency stopping devices and devices to stop the ascending or the descending steps at the entrances and exits of the escalators.</p> <p>5. The constructions of the preceding emergency stopping devices shall be the construction methods specified by the minister of land, infrastructure, and transport so as to have performance which operate automatically and enable to stop the steps safely with the deceleration in operating direction of not more than 1,25 m/s² when power supply fail, break down of driving devices, person or articles are caught, and in case of that persons are liable to be injured or articles are damaged, or the construction methods approved by the minister of land, infrastructure, and transport.</p>

EN 115-1 (Europe)	A17.1/B44 (North America)	Japanese codes
		<p>MOC-N (No.1424-2000)</p> <p>Based on the stipulation of the Art.129-12, item 5 of the Building Standard Law Enforcement Order (1950-Cabinet Order No.338), construction method of braking devices for the escalator is specified as follows.</p> <p>1. The construction method of the braking devices for the escalator shall conform to each paragraph described below.</p> <p>(1) It shall be that the braking devices are used for the escalators conforming to the standard described in Art.129-12, paragraphs 3 to 5 of the Building Standard Law Enforcement Order.</p> <p>(2) It shall be that the escalators are provided with devices to detect the situations described following (a) to (e). [except (d) for the escalator of which inclination is less than 15° and a difference in level between each adjacent steps (except the difference in level that the angle at the nose in the direction of movement of the higher level step is not more than 15°) is less than 4 mm].</p> <p>(a) The extraordinary extension of the step chains.</p> <p>(b) The power is cut off.</p> <p>(c) The door covering the opening surrounding the escalator is closing.</p> <p>(d) The person or the articles are caught between a side of the step and the skirt guard panels near the riding entrance and leaving exit.</p> <p>(e) The person or the articles are caught in the inlet of the handrail.</p>

EN 115-1 (Europe)	A17.1/B44 (North America)	Japanese codes
<p>5.12.1.2.5 Actuation of electric safety devices</p> <p>The components actuating the electric safety devices shall be selected and assembled so that they are able to function properly even under the mechanical stresses resulting from continuous operation.</p> <p>In the case of redundancy type fail safe circuit, it shall be ensured by mechanical or geometric arrangements of the transmitter elements that a mechanical fault cannot cause unnoticed loss of redundancy.</p>		—
<p>5.12.1.2.6 Programmable electronic systems in safety related applications (PESSRAE)</p> <p>Programmable electronic systems in safety related applications shall be designed in accordance with the requirements of EN 62061.</p> <p>If a PESSRAE and a non-safety related system share the same hardware, the requirements for PESSRAE shall be met.</p>	—	—
<p>5.12.2 Controls</p> <p>5.12.2.1 Starting and making available for use the escalator or moving walk</p> <p>5.12.2.1.1 Starting of the escalator or moving walk (or making it available for use when starting is automatic by a user passing a certain point) shall be effected by one or more switches available to authorized persons only (e.g. key-operated switches, switches with detachable lever, switches under lockable protective caps, remote start devices) and be reachable from an area outside the comb intersection line. Such switches shall not function concurrently as main switches described in 5.11.4. The person who operates the switch shall either be able to see the entire escalator or entire moving walk or shall have means of ensuring that nobody is using the escalator or moving walk before making this operation. The direction of travel shall be distinctly recognizable from the indication on the switch.</p>	<p>6.1.6/6.2.6 Operating and safety devices</p> <p>6.1.6.1/6.2.6.1.1 General</p> <p>Operating and safety devices conforming to the requirements of this section shall be provided. When more than one driving machine per escalator/moving walk is utilized, actuation of devices covered by this section shall simultaneously control all driving machines.</p> <p>6.1.6.2/6.2.6.2 Starting and inspection control switches</p> <p>6.1.6.2.1/6.2.6.2.1 Escalators/moving walks shall be provided with starting switch(es) conforming to the following.</p> <p>(a) <i>Location and design.</i> The switch(es) shall be</p> <p>(1) located so that the escalator steps are/exposed treadway is within sight;</p> <p>(2) key operated, of the continuous-pressure spring-return type, and shall be operated by a cylindertype lock having not less than a five-pin or</p>	<p>BSLJ-E0129-12, EXP.4 (notice of designing)</p> <p>Starting of the escalator shall be effected by key switches available to authorized persons only.</p>

EN 115-1 (Europe)	A17.1/B44 (North America)	Japanese codes
<p>Any one of the faults envisaged in 5.12.1.1.2 in the electric equipment of the escalator or moving walk, if it cannot be excluded under conditions described in 5.12.1.1.3 and/or Annex B, shall not cause a start of the machine.</p> <p>The starting switch(es) shall be located within reach of a stop switch.</p> <p>For remote starting devices, the requirements above shall apply.</p> <p>NOTE See 7.4.1 e) for the obligation of the maintainer to observe a complete revolution of the step/pallet band before making the escalator/moving walk available to the public after maintenance.</p>	<p>five-disk combination;</p> <p>(3) clearly and permanently marked “DOWN/TOWARDS,” “RUN”, and “UP/ AWAY” in that order with the key removable only in the “RUN” (spring return) position. The switch(es) shall be rotated clockwise to go from the “DOWN/TOWARDS” to “RUN” to “UP/ AWAY” position.</p> <p>(c) The starting switch(es) shall be located within reach of an emergency stop button (see 6.1.6.3.1/6.2.6.3.1).</p> <p>(d) The key shall be of group 2 security (see 8.1).</p>	
<p>5.12.2.1.2 Escalators or moving walks which start or accelerate automatically by the entering of a user (stand-by-operation) shall move with at least 0,2 times the nominal speed when the person reaches the comb intersection line and then accelerate less than 0,5 m/s².</p> <p>NOTE An average speed for a walking person of 1 m/s should be taken into account.</p> <p>The requirements of 5.12.1.1 shall be met.</p> <p>Constructional measures may be necessary to prevent circumvention of the control elements.</p>	<p>(b) <i>Operating requirements.</i> The operation of the switch(es) shall initiate movement of the escalator/ moving walk. The escalator shall not start (restart), unless all starting switch(es) were first in the “RUN” position.</p>	<p>JEAS-410B</p> <p>3. Description</p> <p>3.1 Automatic operation</p> <p>(1) When the stopped escalator detects passengers approaching at the entrance, it shall automatically start running and continue operation until the last passenger reaches the exit.</p> <p>(2) The running direction for the automatic operation shall be restricted to either upward or downward movement by the key operation.</p> <p>3.2 The detecting point of the detection device</p> <p>The detecting point shall be placed at a point where the escalator starts moving and can reach to a stable speed prior to passengers getting on. It shall be located at a distance of 1,0 m or more from the turning end of the handrail or 1,7 m or more from the edge of the combs and shall be located at both the landing entrance and the exit (an example of the photo-electric device is shown in Figure 1).</p>

EN 115-1 (Europe)	A17.1/B44 (North America)	Japanese codes
<p>5.12.2.1.3 On escalators or moving walks which start automatically by the entering of a user, the direction of travel shall be predetermined, clearly visible to the user, and marked distinctly on the escalator/moving walk (see 7.2.2).</p> <p>In such cases where escalators or moving walks which start automatically by the entering of a user can be entered in the direction opposite its predetermined direction of travel, they shall start in the predetermined direction and conform to the requirements of 5.12.2.1.2. The running time shall be not less than 10 s.</p>	<p>6.1.6.1.1/6.2.6.1.2 Automatic operation. Automatic starting by any means, or automatic stopping, except as required in 6.1.6/6.2.6, shall be prohibited.</p>	<p>JEAS 410 B A</p> <p>3.3 Prevention against the entering from the exit side</p> <p>When the stopped escalator detects passengers approaching at the exit, it shall give them a warning, begin running in the predetermined direction by the key operation for a fixed time, and show them that the escalator is not serviceable to prevent them from entering in the wrong direction.</p> <p>3.4 Indications, instructions, and notices</p> <p>(1) At the entrance, it should be indicated that passengers are allowed to get on.</p> <p>(2) At the exit, it should be indicated that passengers are not allowed to get on.</p> <p>(3) The indications should be located at a place where the approaching passengers can see them easily.</p>
	<p>6.1.6.13/6.2.6.12 Completion or maintenance of circuit. The completion or maintenance of an electric circuit shall not be used to stop the escalator/moving walk when the emergency stop switch is opened or when any of the electrical protective devices operate. These requirements do not apply to electrically assisted braking or speed control switches (see 6.1.6.3.2/6.1.6.3.2, 6.1.6.3.8/6.2.6.3.7, and 6.1.6.4/6.2.6.4).</p>	<p>BSLJ-EO; Article 129-12</p> <p>4. Escalators shall be provided with the emergency stopping devices and devices to stop the ascending or the descending steps at the entrances and exits of the escalators.</p>
<p>5.12.2.2 Stopping</p> <p>5.12.2.2.1 Stopping by operator, manually operated</p> <p>Before stopping, the person shall have means of ensuring that nobody is using the escalator or moving walk before making this operation. For remote stopping devices, the same requirements apply.</p>	<p>6.1.6.3.1 Emergency stop buttons. In jurisdictions, not enforcing National Building Code of Canada (NBCC) remote stop buttons are prohibited. In jurisdictions enforcing NBCC, if remote buttons are provided, they shall be located within view of the escalator.</p>	<p>BSLJ-EO; Article 129-12.4.Exp. Notice of design</p> <p>Before stopping, the person shall have means of ensuring that nobody is using the escalator or moving walk before making this operation. For remote stopping devices, the same requirements apply.</p>

EN 115-1 (Europe)	A17.1/B44 (North America)	Japanese codes
<p>5.12.2.2.2 Stopping, automatically operated</p> <p>It is permitted to design the control in such a way that the escalator or moving walk is stopped automatically after a sufficient time (at least the anticipated user transfer time plus 10 s) after the user has actuated a control element described in 5.12.2.1.1.</p>	<p><i>Comment: Automatic starting and stopping will be allowed in A17.1/B44-2010 code revision onwards. A17.1/B44 - 2007 still has following requirement</i></p> <p>6.1.6.1.1 Automatic operation. Automatic starting by any means, or automatic stopping, except as required in 6.1.6, shall be prohibited.</p>	<p>JEAS-410 B</p> <p>3. Description</p> <p>3.2 Automatic operation</p> <p>(1) When the stopped escalator detects passengers approaching at the entrance, it shall automatically start running and continue operation until the last passenger reaches the exit.</p>
<p>5.12.2.2.3 Stop switch for emergency situations, manually operated</p> <p>5.12.2.2.3.1 Stop switch for emergency situations shall be provided to stop the escalator or moving walks in the event of an emergency. They shall be placed in conspicuous and easily reachable positions at least at or near each landing of the escalator or moving walk (see 7.2.1.2.2 for optical design).</p> <p>The distances between stop switches for emergency situations shall not exceed</p> <ul style="list-style-type: none"> - 30 m on escalators, and - 40 m on moving walks. <p>If necessary, additional stop switches shall be provided to maintain the distance.</p> <p>For moving walks intended to transport shopping trolleys and baggage carts, see I.2.</p>	<p>6.1.6.3.1/6.2.6.3.1 Emergency stop buttons</p> <p>(a) <i>Location.</i> In jurisdictions not enforcing NBCC, a red stop button shall be visibly located at the top and the bottom landings on the right side facing the escalator/moving walk.</p> <p>Remote stop buttons are prohibited. In jurisdictions enforcing NBCC, a red stop button shall be visibly located at the top and the bottom landings on the right side facing the escalator/moving walk. If auxiliary emergency-stop buttons are provided, they shall be located within view of the escalator/moving walk</p> <p><i>Comment: In both NBCC and non enforced NBCC jurisdictions, the emergency stop buttons are required as described below. The only difference is that jurisdictions enforcing NBCC allow remote stop buttons as long as they are in view of the escalator or moving walk.</i></p> <p>(1) On high deck balustrades, they shall be located on the curved newel deck in the upper quadrant, with the centerline of the button at a 45° angle from the horizontal.</p> <p>(2) On low deck balustrades, they shall be located below the handrail height. The centerline of the button shall be located on a radial line 45° above the horizontal such that no part of the button assembly is within 38 mm (1,5 in.) of the bottom of the handrail and the button is no more than 90 mm (3,5 in.) from the bottom of the handrail.</p>	<p>BSLJ-EO; Article 129-12</p> <p>4. Escalators shall be provided with the emergency stopping devices and devices to stop the ascending or the descending steps at the entrances and exits of the escalators.</p>

EN 115-1 (Europe)	A17.1/B44 (North America)	Japanese codes
	<p>(b) Cover, alarm, and marking. The buttons shall be covered with a transparent cover that can be readily lifted or pushed aside. When the cover is moved, an audible warning signal shall be activated. The signal shall have a sound intensity of 80 dBA minimum at the button location. The cover shall be marked "EMERGENCY STOP", "MOVE COVER", or equivalent legend (e.g. "LIFT COVER", "SLIDE COVER") and "PUSH BUTTON." "EMERGENCY STOP" shall be in letters not less than 12 mm (0,5 in.) high. Other required wording shall be in letters not less than 4,8 mm (0,188 in.) high. The cover shall be self-resetting.</p> <p>(c) Operation. The operation of either of these buttons shall cause the electric power to be removed from the escalator/moving walk driving-machine motor and brake. It shall not be possible to start the escalator/moving walk by these buttons.</p>	
<p>5.12.2.2.3.2 Stop switch for emergency situations shall be electric safety devices according to 5.12.1.2.</p> <p>NOTE Devices according to ISO 13850 do not support the functional requirement for stop switches according to 5.12.2.2.3. For the specific purpose of safety for escalators and moving walks, the stop switch for emergency situations is defined different to ISO 13850.</p>	—	

EN 115-1 (Europe)	A17.1/B44 (North America)	Japanese codes
<p>5.12.2.2.4 Stopping initiated by monitoring or electric safety devices (see 5.12.1.2.1.1)</p> <p>5.12.2.2.4.1 In case of any event detected by a monitoring or electric safety device, as listed in Table 6, the driving machine shall be prevented from starting or shall be stopped immediately before a restart procedure (see 5.12.2.4).</p> <p>References to the relevant requirements for each monitoring and electric safety device are given in Table 6:</p>	<p>6.1.6.10.1/6.2.6.9.1 The occurrence of a single ground or the failure of any single magnetically operated switch, contactor, or relay, or any single solid-state device, or a software system failure shall not</p> <p>(a) permit the escalator/moving walk to start;</p> <p>(b) render ineffective any electrical protective device required by 6.1.6.3/6.2.6.3;</p> <p>(c) render ineffective the handrail speed-monitoring device required by 6.1.6.4/6.2.6.4;</p> <p>(d) render ineffective the missing step/pallet device required by 6.1.6.5/6.2.6.5;</p> <p>(e) render ineffective the missing dynamic skirt device required by 6.1.6.5;</p>	<p>—</p>
	<p>(f) permit the escalator to revert to normal operation when on inspection operation [see 6.1.6.2.2/6.2.6.2.2)].</p> <p>NOTE [6.1.6.10.1 (b) through (e)/6.2.6.9.1 (b) through (d)]: Requirements only apply to the circuits in which the devices are used and not the devices themselves.</p> <p>6.1.6.13/6.2.6.12 Completion or maintenance of circuit. The completion or maintenance of an electric circuit shall not be used to stop the escalator/moving walk when the emergency stop switch is opened or when any of the electrical protective devices operate. These requirements do not apply to electrically assisted braking or speed control switches (see 6.1.6.3.2/6.1.6.3.2, 6.1.6.3.8/6.2.6.3.7, and 6.1.6.4/6.2.6.4).</p>	
<p>Table 6 — Requirements for monitoring and electric safety devices</p> <p>Events to be detected.</p> <p>a) Overload (by means of automatic circuit breakers). Starting shall be prevented (see also 5.12.2.4.1).</p> <p>b) Overload (operated on basis of temperature increase).</p>	<p>6.1.7.4.1 All electrical equipment and wiring shall conform to NFPA 70 or CSA-C22.1, whichever is applicable (<i>ref. NFPA 70, Rule 620.61</i>).</p>	<p>Addressed in JEAC 8001- 2005 ;3705-5</p> <p>Requirement for motor overload protection</p> <p>Motor shall be protected against overload by means of automatic circuit breakers, fuse for motor circuit application, thermal relay, induction type relay, static relay, et al.</p> <p>No requirement in Japanese escalator code.</p>

EN 115-1 (Europe)	A17.1/B44 (North America)	Japanese codes
c) Excessive speed or unintentional reversal of the direction of travel (according to 5.4.2.3). Starting shall be prevented (see also 5.12.2.4.1).	<p>6.1.6.3.2/6.2.6.3.2 Escalator/moving walk speed-monitoring device. An escalator/moving walk speed-monitoring device shall be provided.</p> <p>(a) The operation of the device shall cause the electric power to be removed from the driving machine motor and brake should the speed exceed the rated speed by more than 20 %.</p> <p>(b) The device shall be of the manual-reset type.</p> <p>6.1.6.3.8/6.2.6.3.7 Reversal stop device. Means shall be provided to cause the electric power to be removed from the driving-machine motor and brake in case of reversal of travel while the escalator/moving walk is operating in the ascending direction. The device shall be of the manual-reset type.</p>	
d) Closing of the auxiliary brake (according to 5.4.2.2.4).	<p>6.1.6.3.4/6.2.6.3.4 Drive-chain device. When the driving machine is connected to the main drive shaft by a chain, a device shall be provided that will cause the application of the brake on the main drive shaft and also cause the electric power to be removed from the driving-machine motor and brake if the drive chain between the machine and the main drive shaft becomes disengaged from the sprockets. The device shall of the manual-reset type.</p>	—

EN 115-1 (Europe)	A17.1/B44 (North America)	Japanese codes
<p>e) Breakage or undue elongation of parts immediately driving the steps, pallets, or the belt, e.g. chains or racks. Starting shall be prevented (see also 5.12.2.4.1).</p>	<p>6.1.6.3.3 Broken step-chain device (a) A broken step-chain device shall be provided which shall cause the electric power to be removed from the driving-machine motor and brake. (1) If a step chain breaks. (2) Where no automatic chain tension device is provided if excessive sag occurs in either step chain. (b) The device shall be of the manual-reset type.</p> <p>6.2.6.3.3 Broken treadway device. A broken treadway device shall be provided that shall cause the electric power to be removed from the driving-machine motor and brake if the connecting means between pallets or the belt breaks. The device shall be of the manual reset type.</p>	<p>MOC-N (No.1424-2000) Based on the stipulation of the Art.129-12, item 5 of the Building Standard Law Enforcement Order (1950-Cabinet Order No.338), construction method of breaking devices for the escalator is specified as follows. 1. The construction method of the braking devices for the escalator shall conform to each paragraph described below. (1) It shall be that the braking devices are used for the escalators conforming to the standard described in Art.129-12, paragraphs 3 to 5 of the Building Standard Law Enforcement Order (2) It shall be that the escalators are provided with devices to detect the situations described following (a) to (e). [except (d) for the escalator of which inclination is less than 15° and a difference in level between each adjacent steps (except the difference in level that the angle at the nose in the direction of movement of the higher level step is not more than 15°) is less than 4 mm]. (a) The extraordinary extension of the step chains.</p>
<p>f) (Unintended) extension or reduction of the distance between the driving and return devices</p>	<p>—</p>	<p>—</p>
<p>g) Foreign bodies being trapped at the point where the steps, pallets, or the belt enter the comb (according to 5.7.3.2.6)</p>	<p>6.1.6.3.13/6.2.6.3.11 Comb-step/pallet impact devices. Devices shall be provided which will cause the opening of the power circuit to the escalator/moving walk driving machine motor and brake if either: (a) a horizontal force lbf in the direction of travel is applied at either side or not greater than 3 560 N (800 lbf) at the centre of the front edge of the comb-plate; or (b) a resultant vertical force not greater than 670 N (150 lbf) in the upward direction is applied at the centre of the front of the combplate. These devices shall be of the manual reset type.</p>	<p>—</p>

EN 115-1 (Europe)	A17.1/B44 (North America)	Japanese codes
<p>h) Stopping of a succeeding escalator or moving walk where an intermediate exit does not exist (see A.2.6) or the exit of the escalator or moving walk by structural measures is blocked (e.g. shutters, fire protection gates) (see Annex I for additional stop switch for emergency situation).</p>	<p>6.1.6.6/6.2.6.6 Tandem operation. Tandem operation escalators/ moving walks shall be electrically interlocked where traffic flow is such that bunching will occur if the escalator/moving walk carrying passengers away from the intermediate landing stops.</p> <p>The electrical interlocks shall stop the escalator/moving walk carrying passengers into the common intermediate landing if the escalator/moving walk carrying passengers away from the landing stops. These escalators/moving walks shall also be electrically interlocked to ensure that they run in the same direction.</p>	<p>—</p>
<p>i) Foreign bodies being trapped in the handrail entry (see 5.6.4.3).</p>	<p>6.1.6.3.12/6.2.6.3.10 Handrail entry device. A handrail entry device shall be provided at each newel. It shall be operative in the newels in which the handrail enters the balustrade. It shall be of the manually reset type and shall cause the escalator/moving walk to stop by removing power from the driving-machine motor and brake. It shall operate in either of two ways:</p> <p>(a) if an object becomes caught between the handrail and the handrail guard;</p> <p>(b) if an object approaches the area between the handrail and the</p>	<p>MOC-N (No.1424-2000)</p> <p>Based on the stipulation of the Art.129-12, item 5 of the Building Standard Law Enforcement Order (1950-Cabinet Order No.338), construction method of braking devices for the escalator is specified as follows.</p> <p>1. The construction method of the braking devices for the escalator shall conform to each paragraph described below.</p> <p>(1) It shall be that the braking devices are used for the escalators conforming to the standard described in Art.129-12,</p>
	<p>handrail guard.</p> <p>For those units that rely on an opening of the balustrade to prevent entrapment, all handrail entry devices shall be operative whenever the handrails are operating.</p>	<p>paragraphs 3 to 5 of the Building Standard Law Enforcement Order.</p> <p>(2) It shall be that the escalators are provided with devices to detect the situations described following (a) to (e). [except (d) for the escalator of which inclination is less than 15° and a difference in level between each adjacent steps (except the difference in level that the angle at the nose in the direction of movement of the higher level step is not more than 15°) is less than 4 mm].</p> <p>(e) The person or the articles are caught in the inlet of the handrail.</p>

EN 115-1 (Europe)	A17.1/B44 (North America)	Japanese codes
<p>j) Sagging of step or pallet (see 5.7.2.5). Starting shall be prevented (see also 5.12.2.4.1).</p> <p>Paragraph j) does not apply to belt moving walks (see 5.7.2.5).</p>	<p>6.1.6.3.11 Step level device. Step level devices shall be located at the top and bottom of the escalator. These devices shall detect downward displacement of 3 mm (0,125 in.) or greater at the riser end at either side of the step. When activated, the device shall cause the escalator to stop before the step enters the combplate. The device shall cause power to be removed from the driving-machine motor and brake. Devices shall be of the manual-reset type.</p>	<p>—</p>
	<p>6.2.6.3.9 Pallet level device. Moving walks equipped with pallets with trail wheels shall be provided with pallet level devices located at the top and bottom of the moving walk. These devices shall detect downward displacement of 3 mm (0,125 in.) or greater at the trailing edge of the pallet at either side of the pallet. When activated, the device shall cause the moving walk to stop prior to the pallet entering the combplate. The device shall cause power to be removed from the driving-machine motor and brake. Devices shall be of the manually reset type.</p>	
<p>k) Missing step/pallet (see 5.3.6). Starting shall be prevented (see also 5.12.2.4.1).</p>	<p>6.1.6.5/6.2.6.5 Missing step/pallet and missing dynamic skirt devices</p> <p>(a) A device shall be provided to detect a missing step/pallet and bring the escalator/moving walk to a stop before the gap resulting from the missing step/pallet emerges from the comb. The device shall cause power to be removed from the driving-machine motor and brake. The device shall be of the manual-reset type.</p>	<p>—</p>
<p>—</p>	<p>(b) For escalators with dynamic skirts, a device shall be provided to detect a missing dynamic skirt panel and bring the escalator to a stop before the gap resulting from the missing dynamic skirt panel emerges from the balustrade. The device shall cause power to be removed from the driving-machine motor and brake. The device shall be of the manual-reset type.</p>	<p>—</p>
<p>l) Non-lifting of the braking system after starting the escalator or moving walk (see 5.4.2.1.1). Starting shall be prevented (see also 5.12.2.4.1).</p>	<p>—</p>	<p>—</p>

EN 115-1 (Europe)	A17.1/B44 (North America)	Japanese codes
m) Hand rail speed deviation of more than -15 % to the actual speed for more than 15 s (see 5.6.1).	6.1.6.4/6.2.6.4 Handrail-speed monitoring device. A handrail speed monitoring device shall be provided that will cause the activation of the alarm required by 6.1.6.3.1 (b)/6.2.6.3.1 (b) without any intentional delay whenever the speed of either handrail deviates from the step speed by 15% or more. The device shall also cause electric power to be removed from the driving-machine motor and brake when the speed deviation of 15% or more is continuous within a 2 s to 6 s range. The device shall be of the manual-reset type.	BSLJ-E0; Article 129-12 1.(3) Escalators shall be provided with handrails at each side of steps (the portion going up and down on which the persons step). The upper surface of the handrails shall move in the same direction and at the same speed as the steps. JIS A 4302-2006, 5.4.2 (d) A handrail shall be moved in the same direction and at substantially the same speed as the steps.
n) Opened inspection cover in the area of the truss and/or removed or opened floor plate (see 5.2.4).	—	—
o) Exceeding the maximum permitted stopping distances by more than 20 % (see 5.4.2.1.1). Starting shall be prevented.	—	—
p) Fault to earth of a circuit in which there is an electric safety device. Starting shall be prevented (see also 5.12.1.1.4).	—	—
q) Installation of a removable hand winding device (see 5.4.1.4).	—	—
(r)	6.1.6.3.6 Escalator skirt obstruction device. Means shall be provided to cause the electric power to be removed from the escalator driving-machine motor and brake if an object becomes caught between the step and the skirt as the step approaches the upper or lower combplate. The device shall be located at a point at which the step assumes a flat step position (see 6.1.3.6.5). The escalator shall stop before that object reaches the combplate with any load up to full brake rated load with escalator running [see 6.1.3.9.3 (a) (2) and (b) (2)]	MOC-N (No.1424-2000) Based on the stipulation of the Art.129-12, item 5 of the Building Standard Law Enforcement Order (1950-Cabinet Order No.338), construction method of braking devices for the escalator is specified as follows. 1. The construction method of the braking devices for the escalator shall conform to each paragraph described below. (1) It shall be that the braking devices are used for the escalators conforming to the standard described in Art.129-12,

EN 115-1 (Europe)	A17.1/B44 (North America)	Japanese codes
	<p>6.1.6.3.16 Dynamic skirt panel obstruction device. Means shall be provided to cause the electric power to be removed from the escalator driving machine motor and brake if an object becomes caught between the dynamic skirt panel and the dynamic skirt panel cover in the upper or lower transition zone. The device shall be of the manual-reset type.</p>	<p>paragraphs 3 to 5 of the Building Standard Law Enforcement Order</p> <p>(2) It shall be that the escalators are provided with devices to detect the situations described following (a) to (e). [except (d) for the escalator of which inclination is less than 15° and a difference in level between each adjacent steps (except the difference in level that the angle at the nose in the direction of movement of the higher level step is not more than 15°) is less than 4 mm].</p> <p>(d) The person or the articles are caught between a side of the step and the skirt guard panels near the riding entrance and leaving exit.</p>
(s)	<p>6.1.6.3.7/6.2.6.3.6 Escalator egress restriction device.</p> <p>Egress restrictors that would prevent the free and continuous exiting of passengers, if used, shall provide a signal to a device on the escalator/moving walk that shall cause the electric power to be removed from the escalator/moving walk driving machine motor and brake when the exit restrictors begin to close.</p>	<p>MOC-N (No.1424-2000)</p> <p>1 (2) (c) The door covering the opening surrounding the escalator is closing.</p> <p>JEAS-A407</p> <p>2. Description</p> <p>2.1 Escalator required for interlocking suspension (Refer to Figure 1).</p> <p>If a shutter facing with a landing of the escalator is located within 2 m from the turning end of the handrails, the escalator is required to suspend operation interlocking with the shutter which starts closing. Furthermore, if the other shutters, including the above shutter, form an area and start closing at the same time, the escalator may be interlocked with any one of them.</p>
		<p>2.2 Contacts for interlocking (refer to Figure 2 and Figure 3).</p> <p>A contact for interlocking to be provided at the shutter shall be "b" contact (contact to be opened before the closing shutter comes down to a height of 1,8 m above floor level) of DC 125V 0.2A (AC 250V 1A) in rating and number of contacts shall be same as number of escalators necessary to be interlocked.</p>

EN 115-1 (Europe)	A17.1/B44 (North America)	Japanese codes
		<p>2.3 Piping and wiring (refer to Figure 2 and Figure 3).</p> <p>Lead-in piping and wiring from a contact for interlocking with the shutter to the escalator machine room shall not be passed through inside of the escalator truss, but shall be separately installed for every escalator necessary to be interlocked.</p> <p>3. Related matters</p> <p>The shutter facing the landing of the escalator shall be located 1,2 m or more from the turning end of the handrails.</p>
(t)	<p>6.1.6.3.9 Step upthrust device. Means shall be provided in the passenger-carrying line of the track system to detect a step forced upward in the lower transition curve at or prior to the point of tangency of the horizontal and curved track. The means shall actuate when the riser end of the step is displaced upward more than 5 mm (0,20 in.) at the lower landing. Actuation of the means shall cause power to be removed from the driving-machine motor and brake. The escalator shall stop before the detected step reaches the combplate with any load up to brake rated load with escalator running [see 6.1.3.9.3 (a) (2) and (b) (2)].</p>	—
(u)	<p>6.1.6.3.10/6.2.6.3.8 Disconnected motor safety device. If the drive motor is attached to a gear reducer by means other than a continuous shaft, mechanical coupling, or toothed gearing, a device shall be provided that will cause the electric power to be removed from the drivingmachine motor and brake (see 6.1.5.3.1/6.2.5.3.1) if the motor becomes disconnected from the gear reducer. The device shall be of the manual-reset type.</p>	—

EN 115-1 (Europe)	A17.1/B44 (North America)	Japanese codes
(v)	<p>6.1.6.3.14 Step lateral displacement device. A device shall be provided on curved escalators to cause the opening of the power circuit to the escalator driving machine motor and brake should a step be excessively displaced horizontally due to a failure in the lateral support system. The device shall be of the manual reset type.</p>	—
<p>5.12.2.2.4.2 The implementation for switching-off operations of monitoring and electrical safety devices into a safety circuit shall fulfill the requirements of Annex B.</p>	<p><i>These are items addressed in the National Electrical Code, ANSI/NFPA 70</i></p>	—
—	<p>6.1.6.8/6.2.6.7 Escalator/moving walk smoke detectors. Smoke detectors shall be permitted that shall activate the alarm required by 6.1.6.3.1 (b)/6.2.6.3.1 (b) and, after at least 15 s, shall cause the interruption of power to the driving-machine motor and brake.</p>	—
<p>5.12.2.3 Reversal of direction of travel An intended reversal of the direction of travel shall be possible only if the escalator or moving walk stands still and 5.12.2.1, 14.2.1.1, 5.12.2.1.2, 5.12.2.1.3, and 5.12.2.2.2 are complied with.</p>	<p>6.1.6.10/6.2.6.9 Control and operating circuits. The design and installation of the control and operating circuits shall conform to 6.1.6.10.1/6.2.6.9.1 through 6.1.6.10.4/6.2.6.9.4.</p> <p>6.1.6.10.1/6.2.6.9.1 The occurrence of a single ground or the failure of any single magnetically operated switch, contactor, or relay, or any single solid-state device, or a software system failure, shall not</p> <p>(a) permit the escalator/moving walk to start;</p> <p>(b) render ineffective any electrical protective device required by 6.1.6.3/6.2.6.3;</p> <p>(c) render ineffective the handrail speed-monitoring device required by 6.1.6.4/6.2.6.4;</p>	—

EN 115-1 (Europe)	A17.1/B44 (North America)	Japanese codes
	<p>(d) render ineffective the missing step/pallet device required by 6.1.6.5;</p> <p>(e) render ineffective the missing dynamic skirt device required by 6.1.6.5;</p> <p>(f) permit the escalator/moving walk to revert to normal operation when on inspection operation (see 6.1.6.2.2/6.2.6.2.2).</p> <p>NOTE [6.1.6.10.1 (b) through (e)/6.2.6.9.1 (b) through (d)]: Requirements only apply to the circuits in which the devices are used and not the devices themselves.</p>	
<p>5.12.2.4 Restarting</p> <p>5.12.2.4.1 Restarting by switch</p> <p>After each stop (5.12.2.2.1, 5.12.2.2.3, 5.12.2.2.4), except the one mentioned in 5.12.2.2.2, restarting shall be possible only by means of the switches mentioned in 5.12.2.1 or by means of the inspection control described in 5.12.2.5. It shall be observed that where stopping is effected in the cases as listed in a), c), e), j), k), l), o), p), and q) of Table 6, restarting shall be possible only after the failure lock has been manually reset.</p> <p>Before manual reset, the root cause for stopping has to be investigated, the stopping device has to be checked, and corrective action has to be taken if necessary.</p> <p>The failure lock shall remain active even following failure or reinstatement of the power supply</p>	<p>6.1.6.14/6.2.6.13 Escalator/moving walk manual reset where manual reset is required, interruption of power to the escalator/moving walk shall not cause a safety device to lose the status of the event upon return to power. The cause of the malfunction shall be indicated in some manner so that an examination will be made prior to restarting the escalator/moving walk. The starting switch shall not be operable until the reset for each activated device is accomplished.</p>	—

EN 115-1 (Europe)	A17.1/B44 (North America)	Japanese codes
<p>5.12.2.4.2 Reactivation for automatic restart</p> <p>Where stopping is effected by a stop switch for emergency situation according to 5.12.2.2.3, reactivation of the escalator or moving walk for automatic restart without the switches mentioned in 5.12.2.1 is permitted under the following conditions.</p> <p>a) The steps, pallets, or the belt shall be supervised between the comb intersection lines and additional 0,30 m beyond each comb so that reactivation for automatic restart is effected only when there is no person or object within this zone.</p>	<p><i>Automatic starting or restarting is not permitted in the A 17.1 code.</i></p> <p>—</p>	
<p>The device shall be able to detect an opaque upright standing cylinder with a diameter of 0,30 m and a height of 0,30 m at any place within this zone.</p> <p>b) The escalator or moving walk shall start by the entering of a user according to 5.12.2.1.2.</p> <p>Starting shall be effected only if, for a period of at least 10 s, the control device has not detected any persons or objects within the defined zone.</p> <p>c) The reactivation control initiated by the control device for automatic restart shall be an electric safety device according to 5.12.1.2. Self controlling transmitter elements are permitted in single-channel design.</p>		

EN 115-1 (Europe)	A17.1/B44 (North America)	Japanese codes
<p>5.12.2.5 Inspection control</p> <p>5.12.2.5.1 Escalators or moving walks shall be equipped with inspection controls to permit operation during maintenance or repair or inspection by means of portable and manually operated control devices.</p>	<p>6.1.6.3.15/6.2.6.3.12 Stop switch in inspection controls. A stop switch conforming to the following requirements shall be provided when required by 6.1.6.2.2/6.2.6.2.2.</p> <p>(a) When opened (“STOP” position), cause the electric power to be removed from the moving walk driving machine motor and brake.</p> <p>(b) Be of the manually opened and closed type.</p> <p>(c) Have red operating handles or buttons.</p> <p>(d) Be conspicuously and permanently marked “STOP” and shall indicate the “STOP” and “RUN” positions.</p> <p>(e) Shall have contacts that are positively opened mechanically and their opening shall not be solely dependent on springs.</p>	—
<p>5.12.2.5.2 For this purpose, one inspection outlet for the connection of the flexible cable of the portable manually operated control device shall be provided at least at each landing, e.g. in the driving station and the return station in the truss. The length of the cable shall be at least 3,0 m. Inspection outlets shall be located in such a way that any point of the escalator or moving walk can be reached with the cable.</p>	<p>6.1.6.2.2/6.2.6.2.2 Inspection control. Each escalator/moving walk shall be equipped with inspection controls not accessible to the general public during normal operation to provide constant pressure operation during maintenance, repair, or inspection by means of a manually operated control device.</p> <p>(a) General requirements</p> <p>(1) Switches for transferring the control of the escalator/moving walk to inspection operation shall be provided or a switch shall be provided at each landing in a portable control station. The switch(es) shall function as follows:</p> <p>(a) be through a contact that shall be positively opened mechanically and whose opening shall not depend solely on springs;</p> <p>(b) be manually operated;</p> <p>(c) be labelled “INSPECTION”;</p> <p>(d) have two positions labelled “INSPECTION” or “INSP” and “NORMAL” or “NORM”;</p>	—

EN 115-1 (Europe)	A17.1/B44 (North America)	Japanese codes
	<p>(e) when in the “INSPECTION” position, it shall cause the movement of the escalator/moving walk to be solely under the control of constant pressure operating device(s) /at the landing or in that portable control station.</p> <p>(2) Constant pressure operating devices shall</p> <p>(a) allow movement of the escalator/moving walk only by constant application of manual pressure,</p> <p>(b) be distinctly recognizable from indications on the device as to the direction of travel controlled,</p> <p>(c) be protected against accidental contact, and</p> <p>(d) be located so that the escalator steps are/moving walk treadway surface is within sight.</p> <p>(3) A stop switch conforming to 6.1.6.3.15/6.2.6.3.12 shall be provided adjacent to the constant pressure operating devices.</p>	
	<p>(4) When portable control stations are used, the cord length shall not exceed 3 000 mm (120 in.) in length.</p> <p>(b) <i>Plug-in portable control station.</i> A plug-in portable control station shall be permitted provided that</p> <p>(1) either a transfer switch conforming to 6.1.6.2.2 (a) (1)/6.2.6.2.2 (a) (1) (a), (a) (1) (b), and (a) (1) (c) is complied with or when plugged in the escalator/moving walk shall automatically transfer to inspection operation;</p> <p>(2) when the switch, if provided, is in the “INSPECTION” position or when the control station is plugged in, it shall cause the movement of the escalator/moving walk to be solely under the control of constant pressure operating devices contained in the portable unit;</p> <p>(3) the plug-in portable control station is stored at the upper landing machinery spaces at that landing or in that portable control station.</p>	

EN 115-1 (Europe)	A17.1/B44 (North America)	Japanese codes
<p>5.12.2.5.3 The operating elements of this control device shall be protected against accidental operation. The escalator or moving walk is permitted to run only as long as the operating elements are switched on by permanent application of manual pressure. The direction of travel shall be distinctly recognizable from the indication on the switch. Each control device shall have a stop switch.</p> <p>The stop switch shall</p> <ul style="list-style-type: none"> a) be operated manually, b) have the switching positions marked clearly and permanently, c) be a safety switch satisfying 5.12.1.2.2, and d) require manual reset. <p>When the inspection control device is plugged in, the operation of the stop switch shall cause the disconnection of the power supply from the driving machine and the operational brake shall be activated.</p>	<p>(g) Be protected against accidental contact.</p>	<p>—</p>
<p>5.12.2.5.4 When the inspection control device is used, all other starting devices shall be rendered inoperative in accordance with 5.12.1.2.</p> <p>All inspection outlets shall be arranged in such a way that when more than one control device is connected, they all become inoperative. The electric safety devices (according to 5.12.2.2.4) shall remain effective with the exception of the electric safety devices mentioned in h), j), k), l), m), and n) of Table 6.</p>	<p>(f) Be arranged so that if more than one inspection transfer switch is in the "INSPECTION" position, then all constant pressure operating devices at all locations shall be inoperative.</p>	<p>—</p>

EN 115-1 (Europe)	A17.1/B44 (North America)	Japanese codes
<p>6 Verification of the safety requirements and/or protective measures</p> <p>6.1 General</p> <p>Table 7 indicates the methods by which the safety requirements and measures described in Clause 5 shall be verified by the manufacturer for each new model of escalator/moving walk, together with a reference to the corresponding subclauses in this standard. Secondary subclauses, which are not listed in the table, are verified as part of the quoted subclause. All verification records shall be kept by the manufacturer.</p> <p>Where mechanical testing is required in accordance with this standard, setting tolerances are permitted.</p> <p><i>(Table 1 — Methods to be used to verify conformity to the requirements)</i></p>	<p>—</p>	<p>—</p>
<p>6.2 Specific data, test reports, and certificates</p> <p>The following documentation should be held by the manufacturer:</p> <ul style="list-style-type: none"> a) stress analysis of the truss or equivalent certificate by a stress analyst; b) proof by calculation of sufficient breakage resistance of the parts directly driving the steps, pallets, or the belt, e.g. step chains, racks; c) calculation of the stopping distances for loaded moving walks (see 5.4.2.1.3.4) together with adjustment data; d) proof testing of steps or pallets; e) proof of the breaking strength of the belt; f) proof of sliding coefficients for skirting; g) proof of anti-slip properties of tread surfaces (steps, pallets, floor, and comb plates without combs); h) proof of stopping distances and deceleration values; i) proof of electromagnetic compatibility. 	<p>—</p>	<p>—</p>

EN 115-1 (Europe)	A17.1/B44 (North America)	Japanese codes
<p>7 Information for use</p> <p>7.1 General</p> <p>All escalators and moving walks are required to be provided with documentation that shall include an instruction handbook relating to use, maintenance, inspection, periodic checks, and rescue operations. All information for use shall be in accordance with ISO 12100-2 and also contain additional provisions for the use of machines within the scope of the standard.</p> <p>Information for use shall cover, separately or in combination, transport, assembly and installation, commissioning, use (setting, teaching/programming, operation, cleaning, fault finding, and maintenance) of the escalator and moving walk, and, if necessary, de-commissioning, dismantling, and disposal.</p>	<p><i>A17.2 is the Inspectors Manual that provides recommended instruction to inspectors on how to check to determine if the A17.1/B44 code requirements are being complied with.</i></p>	—
<p>7.2 Signs, notices for use and signals</p> <p>7.2.1 Plates, inscriptions, and notices for use</p> <p>7.2.1.1 All signs, inscriptions, and notices for use shall be of durable material, placed in a conspicuous position, and written in clearly legible characters in the language of the country where the escalator or moving walk is in operation.</p>	<p>6.1.6.9 Signs</p> <p>6.1.6.9.1/6.2.6.8.1 Caution signs. A caution sign shall be located at the top and bottom landing of each escalator/moving walk readily visible to the boarding passengers.</p> <p>The sign shall include the following wording:</p> <p>(a) "Caution";</p> <p>(b) "Passengers only";</p> <p>(c) "Hold Handrail";</p> <p>(d) "Attend Children";</p> <p>(e) "Avoid Sides".</p>	—
<p>7.2.1.2 Safety signs near the entrances of escalators or moving walks</p> <p>7.2.1.2.1 The following mandatory action signs for the user shall be fixed in the vicinity of the entrances:</p> <p>a) "Small children must be held firmly" (see Figure G.1);</p> <p>b) "Dogs shall be carried" (see Figure G.2);</p> <p>c) "Use the handrail" (see Figure G.3, Reg. Nr. ISO 7010-M012);</p> <p>d) "Push chairs not permitted" (see Figure G.4).</p>	<p>The sign shall be standard for all escalators/moving walks and shall be identical in format, size, colour, wording, and pictorials as shown in Figure 6.1.6.9.1. The sign shall be durable and have a maximum thickness of 6,3 mm (0,25 in.) with rounded or beveled corners and edges.</p> <p>6.1.6.9.2/6.2.6.8.2 Additional signs. Signs in addition to those required by 6.1.6.9.1/6.2.3.8.1 relating to cautions or warnings applying to escalator/moving walk passengers, when provided, shall be in a readily visible location and</p>	—

EN 115-1 (Europe)	A17.1/B44 (North America)	Japanese codes
<p>When required by local conditions, prohibition signs, e.g. “Transportation of bulky and heavy loads not permitted” and mandatory action signs like “Use permitted only with footwear” will possibly be necessary.</p>	<p>limited to conveying any additional cautions and/or warnings. The additional signs shall be prohibited in the area starting from 3 000 mm (118 in.) horizontally outward from the end of the newel.</p> <p><i>(for escalator)</i> and to the point where the steps start to move vertically.</p> <p><i>(for moving walks)</i> along the path of travel and to a point 900 mm (36 in.) from the tread-comb intersection along the treadway.</p> <p>Its location shall not impede or, otherwise, cause persons about to board the escalator to suddenly pause or stop. The sign shall comply with ANSI Z535.2 or CAN/CSA-Z321, whichever is applicable (see Part 9).</p>	
<p>7.2.1.2.2 Stop devices referred to in 5.12.2.2.3 shall be coloured red and either on the device itself or in its immediate vicinity be marked with the inscription “STOP”.</p>	<p>6.1.6.3.1/6.2.6.3.1 Emergency stop buttons</p> <p>(a) <i>Location.</i> In jurisdictions not enforcing NBCC, a red stop button shall be visibly located at the top and the bottom landings on the right side facing the escalator/moving walk.</p> <p>Remote stop buttons are prohibited. In jurisdictions enforcing NBCC, a red stop button shall be visibly located at the top and the bottom landings on the right side facing the escalator/moving walk. If auxiliary emergency-stop buttons are provided, they shall be located within view of the escalator/moving walk.</p> <p><i>Comment: In both NBCC and non enforced NBCC jurisdictions, the emergency stop buttons are required as described below. The only difference is that jurisdictions enforcing NBCC allow remote stop buttons as long as they are in view of the escalator or moving walk.</i></p> <p>(1) On high deck balustrades, they shall be located on the curved newel deck in the upper quadrant with the centerline of the button at a 45° angle from the horizontal.</p> <p>(2) On low deck balustrades, they shall be located below the handrail height. The centerline of the button shall be located on a radial line 45° above the horizontal such that no part of the button assembly is within 38 mm (1,5 in.) of the bottom of the handrail and the button is no more than 90 mm (3,5 in.) from the bottom of the handrail.</p>	<p>BSLJ-E0129-12, 4</p> <p>Emergency stop button shall be located near the upper and lower landings.</p> <p>EXP.(notice of designing)</p> <p>Abuse protection guard should be incorporated in a place where it is easy to operate.</p>

EN 115-1 (Europe)	A17.1/B44 (North America)	Japanese codes
	<p><i>(b) Cover, alarm, and marking.</i> The buttons shall be covered with a transparent cover that can be readily lifted or pushed aside. When the cover is moved, an audible warning signal shall be activated. The signal shall have a sound intensity of 80 dBA minimum at the button location. The cover shall be marked "EMERGENCY STOP", "MOVE COVER", or equivalent legend (e.g. "LIFT COVER", "SLIDE COVER") and "PUSH BUTTON". "EMERGENCY STOP" shall be in letters not less than 12 mm (0,5 in.) high. Other required wording shall be in letters not less than 4,8 mm (0,188 in.) high. The cover shall be self-resetting.</p> <p><i>(c) Operation.</i> The operation of either of these buttons shall cause the electric power to be removed from the escalator/moving walk driving-machine motor and brake. It shall not be possible to start the escalator by these buttons.</p>	
<p>7.2.1.2.3 During maintenance, repair, inspection, or similar work, the access to the escalator or moving walk shall be barred to unauthorized persons by devices</p> <ul style="list-style-type: none"> - which shall bear the notice "No Access", or - the "No Entry" indicator (prohibition sign C,1^a as described in the "Convention on Road Signs and Signals" (Vienna, 8.11.1968) and be available in immediate area. 	—	—
<p>7.2.1.3 Instructions for hand winding devices</p> <p>If a hand winding device is provided, operating instructions for use shall be available in the vicinity. The direction of travel of the escalator or moving walk shall be indicated clearly.</p>	—	—
<p>7.2.1.4 Notices on the access doors to machinery spaces outside the truss, driving, and return stations</p> <p>On access doors to machinery spaces outside the truss, driving, and return stations a notice shall be fixed with the inscription:</p> <p>"Machinery space - danger, access prohibited to unauthorized persons".</p>	—	—

EN 115-1 (Europe)	A17.1/B44 (North America)	Japanese codes
<p>7.2.2 Special indicators for escalators and moving walks starting automatically</p> <p>In the case of escalators or moving walks starting automatically, a clearly visible signal system, e.g. road traffic signals shall be provided indicating to the user whether the escalator or moving walk is available for use and its direction of travel.</p>	<p>A17.1/B44 prohibits automatic starting.</p>	<p>JEAS-410B</p> <p>3.4 Indications, instructions, and notices</p> <p>(1) At the entrance, it should be indicated that passengers are allowed to get on (an example is shown in Figure 2.).</p> <p>(2) At the exit, it should be indicated that passengers are not allowed to get on (an example is shown in Figure 3).</p> <p>(3) The indications should be located at a place where the approaching passengers can see them easily.</p>
<p>7.3 Inspection and test</p> <p>7.3.1 General</p> <p>Escalators and moving walks shall be inspected before their first use after major modifications and at regular intervals.</p> <p>Such inspections and tests should be made by a competent person.</p>	<p><i>The requirements in EN 115-1 Clause 7.3 are addressed in A 17.1, Section 8.10.4.</i></p>	<p>(Inspection on completion of buildings)</p> <p>Article 7</p> <p>1. Upon the completion of the construction work under Article 6, paragraph 1, the building owner shall apply for the inspection by the building official in accordance with ministry of land, infrastructure, and transport order.</p> <p>(Completion of inspection by officials designated by the minister of land, infrastructure, and transport) Article 7-2</p> <p>(Intermediate inspection on buildings) Article 7-3</p> <p>(Intermediate inspection by the official designated by minister of land, infrastructure, and transport or others) Article 7-4</p> <p>(Special issue no inspection of buildings) Article 7-5</p> <p>(Restriction on use of building up to obtaining the certificate of inspection) Article 7-6</p> <p>The Building Standard Law Enforcement Regulation, Article 6</p>

EN 115-1 (Europe)	A17.1/B44 (North America)	Japanese codes
<p>7.3.2 Constructional inspection and acceptance inspection and test</p> <p>The constructional inspection and acceptance inspection and test shall be carried out at the job-site on completion of the escalator or moving walk.</p> <p>For the constructional inspection and acceptance inspection and test, the data specified in 6.2 should form part of a pre-completed test sheet. Furthermore, layout drawings, description of the equipment, and wiring diagrams (current flow chart with legend or explanations and a terminal connection chart) which permit a check of compliance with the safety requirements specified in this standard shall be provided.</p> <p>The constructional inspection comprises the examination of the completed installation for conformity with the required data and with regard to proper workmanship as specified in this standard.</p> <p>The acceptance inspection and test comprises:</p> <ul style="list-style-type: none"> a) overall visual inspection; b) functional test; c) test of electric safety devices with regard to their effective operation; d) test of the brake(s) of the escalator or moving walk under no load for compliance with the prescribed stopping distances (see 5.4.2.1.3.2 and 5.4.2.1.3.4). An examination of the brake adjustment according to the calculation required in 6.2 c) is also necessary. 	<p><i>Acceptance inspections for escalators are addressed in Part 8.10 of A17.1/B44.</i></p>	<p>JIS A 4302-1992 Inspection standard of elevator, escalator, and dumbwaiter</p> <p>2. Inspection items</p> <p>2.1 Completion inspection</p> <p>In the completion inspection, the elevator, etc. are inspected in compliance with every item given in the design documents and also for all the items provided in 4.</p> <p>JEAS-1003B Escalator specifications</p> <p>JEAS-1004B Structural calculation for escalators</p> <p>JEAS-A1021A Report of escalator conditions form after work completion</p>

EN 115-1 (Europe)	A17.1/B44 (North America)	Japanese codes
<p>Additionally, for escalators, a test of the stopping distances under brake load (see 5.4.2.1.3.2) is required unless the stopping distances can be verified by other methods.</p> <p>e) Measurement of the insulation resistance of the different circuits between conductors and earth (see 5.11.1.4). For this measurement, the electronic components shall be disconnected.</p> <p>This needs to include a test of the electric continuity of the connection between the earth terminal(s) in the driving station and the different parts of the escalator or moving walk liable to be live accidentally.</p>		
<p>7.3.3 Inspection and test after major modifications</p> <p>A major modification is a change of the location, a change of the speed, of the electric safety devices, of the braking system, of the drive, of the control, of the step band, of the truss, and of the balustrades. Wherever applicable, the principles set forth for the constructional inspection and acceptance inspection and test (7.3.2) should apply to the new environmental conditions, modified components, and other components which are affected.</p> <p>The replacement of parts by parts of same design is not considered to be a major modification.</p>	<p>A 17.1 addresses alterations in section 8.7</p>	<p>BSLJ-E0146-1,1 Design of notification</p> <p>In case of a major modification which is a change of speed, change of location, replacement, the application permission shall be required.</p>
<p>—</p>	<p><i>Requirements for periodic inspection and tests of escalators are shown in section 8.11.</i></p>	<p>JIS A 4302-1992 Inspection standard of elevator, escalator, and dumbwaiter</p> <p>2. Inspection items</p> <p>2.2 Periodic inspection</p> <p>In the periodic inspection for maintenance and care, inspection is made for all the items provided in 4, except the loading test.</p>

EN 115-1 (Europe)	A17.1/B44 (North America)	Japanese codes
<p>7.4 Accompanying documents (in particular, instruction handbook)</p> <p>7.4.1 Contents</p> <p>The instruction handbook or other written instructions shall contain the following, among others:</p> <p>a) information relating to transport, handling, and storage of the escalator or moving walk, e.g.</p> <ul style="list-style-type: none"> - storage conditions; - dimensions, mass value(s), position of the centre(s) of gravity; - indications for handling (e.g. drawings indicating application points for lifting equipment). <p>b) Information relating to installation and commissioning of the escalator or moving walk, e.g.</p> <ul style="list-style-type: none"> - building interfaces (see Annex A); - fixing/anchoring and vibration dampening requirements; - assembly and mounting conditions; 	<p>A17.1/B44 does not address this issue.</p>	<p>Distribution of "Guideline concerning maintenance of elevatory equipment and control of operation", Notification No.25 of the Building Disaster Prevention Division, Housing Bureau, Ministry of Construction, 1993.</p> <p>Guideline concerning maintenance of elevatory equipment and control of operation.</p> <p>(Measures against personal injuries)</p> <p>Article 8.</p> <p>2. If any accident mentioned in the preceding paragraph occurs, the building owner or custodian (the owners) shall report to the special administrative agency using a form specified in a separate article, satisfying the following terms:</p> <p>(1) immediate reporting on the accident of the elevatory equipment;</p> <p>The immediate reporting shall be made within 24 h from the accident occurrence.</p>

EN 115-1 (Europe)	A17.1/B44 (North America)	Japanese codes
<p>- space needed for use and maintenance;</p> <p>- permissible environmental conditions (e.g. temperature, moisture, vibration, electromagnetic radiation, earthquake, and civil defence);</p> <p>- instructions for connecting to the power supply (particularly, about protection against electric overloading);</p> <p>- advice about waste removal/disposal;</p> <p>- if necessary, recommendations about protective measures which have to be taken by the owner, e.g. additional safeguards (see ISO 12100-1:2003, Figure 1, Note 4), safety distances, safety signs, and signals;</p> <p>c) information relating to the escalator or moving walk itself, e.g.</p> <p>- detailed description of the escalator or moving walk, its fittings, its guards, and/or protective devices;</p> <p>- comprehensive range of applications for which the escalator or moving walk is intended, including prohibited usages, if any, taking into account variations of the original machine, if appropriate;</p>		<p>(2) detailed report on the the accident of the elevatory equipment;</p> <p>The detailed report shall be made within seven days as from the date of completion of the accident treatment.</p> <p>(Periodical inspection and reporting)</p> <p>Article 9.</p> <p>1. The owners of the elevatory equipment designated based upon the standard specified in Article 12, paragraph 2 shall periodically make the qualified person(s) by the Construction Minister (hereinafter called "the qualified") inspect the elevatory equipment once or more annually and shall submit the report of periodic inspection to the special administrative agency through the regional organizations for elevatory equipment.</p> <p>2. The owners shall keep a copy of the report of periodic inspection on elevatory equipment mentioned in the preceding paragraph for at least three years.</p>

EN 115-1 (Europe)	A17.1/B44 (North America)	Japanese codes
<ul style="list-style-type: none"> - diagrams (especially schematic representation of safety functions and layout details); - technical documentation about electric equipment (see EN 60204 series [5]); - documents attesting that the escalator or moving walk complies with the relevant directives; - documents specifying the grade of the slip resistance; d) information relating to the use of the escalator or moving walk, e.g. about the following: <ul style="list-style-type: none"> - intended use; - description of manual controls (actuators); - setting and adjustment; - risks which could not be eliminated by the protective measures taken by the designer; - interdiction to place merchandise between adjacent balustrades or between a balustrade and adjacent building structures; - preventing arrangements in the vicinity of the escalator/moving walk which encourages misuse; - keeping free of unrestricted areas (see A.2.5); 		

EN 115-1 (Europe)	A17.1/B44 (North America)	Japanese codes
<p>- particular risks which may be generated by certain applications (including the use of shopping trolleys and/or baggage carts on escalators and moving walks, see Annex I) and about specific safe measures which are necessary for such applications;</p> <p>- reasonably foreseeable misuse and prohibited usages;</p> <p>- recommendation to not use escalators as regular staircases or emergency exits;</p> <p>- recommendation that, for escalators and moving walks, which otherwise would be exposed to weather conditions, the customer provides a roof or enclosure;</p> <p>- fault identification and location, repair, and restarting after an intervention;</p> <p>- investigations and necessary corrective actions in case of faults requiring manual reset, to be taken before reset and restart.</p> <p>f) information about periodic inspection and tests to ascertain whether the escalator or moving walk is safe in operation, including the following:</p> <p>- electric safety devices with regard to their effective operation;</p> <p>- brake(s) according to 7.3.2 d);</p> <p>- driving elements for visible signs of wear and tear and for insufficient tension of belts and chains;</p> <p>- steps, pallets, or the belt for defects, true run, and guidance;</p> <p>- dimensions and tolerances specified in this standard;</p> <p>- combs for proper condition and adjustment;</p> <p>- interior panel and the skirting;</p> <p>- handrails;</p>		

EN 115-1 (Europe)	A17.1/B44 (North America)	Japanese codes
<p>- test of the electric continuity of the connection between the earth terminal(s) in the driving station and the different parts of the escalator or moving walk liable to be live accidentally;</p> <p>g) information for emergency situations, e.g.</p> <p>- the operating method to be followed in the event of accident or breakdown;</p> <p>- use of hand winding device, if any (see 5.4.1.4 and 7.2.1.3);</p> <p>- warning about possible emission or leakage of harmful substance(s), and if possible, indication of means to fight their effects;</p> <p>h) a declaration that the emission sound pressure level measured under free field conditions at a distance of 1 m from the surface of the machinery and at a height of 1,6 m from the floor plate is expected not to exceed 70 dB(A).</p>		
<p>7.4.1</p> <p>e) information for maintenance, e.g.</p> <p>- necessity to follow the requirements of EN 13015:2001 for escalators or moving walks;</p> <p>- personal protective equipment which need to be used and training required;</p> <p>- nature and frequency of inspections;</p> <p>- instructions relating to maintenance operations which require a definite technical knowledge or particular skills and hence, should be carried out exclusively by skilled persons (e.g. maintenance staff, specialists);</p> <p>- instructions relating to maintenance actions (e.g. replacement of parts) which do not require specific skills and hence, may be carried out by the owner;</p> <p>- drawings and diagrams enabling</p>	<p><i>A17.1/B44 does not address this issue.</i></p>	<p>BSLJ (Maintenance)</p> <p>Article 8</p> <p>The owner, custodian, or occupant of a building shall endeavour to maintain the site, structure, and building equipment of the building in a state complying with legal requirements.</p> <p>2. The owner or custodian of a building as specified in Article 12, paragraph 1 shall prepare standards plans for the maintenance of the building and take other appropriate measures as the need arises in order to maintain the site, structure, and building equipment of the building in a state complying with legal requirements. In this case, the minister of construction may determine guidelines necessary for the preparation of such standards or plans.</p> <p>(Reports, inspection, etc.)</p>

EN 115-1 (Europe)	A17.1/B44 (North America)	Japanese codes
<p>maintenance personnel to carry out their task rationally (especially fault-finding tasks);</p> <ul style="list-style-type: none"> - instructions relating to cleaning and refurbishment; - necessity for the maintainer to observe a complete revolution of the step/pallet band before making the escalator/moving walk available to the public after maintenance; - instructions on the necessary use of inspection controls during maintenance and repair work; 		<p>Article 12</p> <p>2. The owners of elevatory equipment and those of building equipment other than elevatory equipment (including building equipment installed in buildings of the State, a prefecture, or a city, town, or village having building officials) of a building as mentioned in Article 6, paragraph 1, item (1) or any other building specified by cabinet order as mentioned in the preceding paragraph and designated by the special administrative agency shall, in accordance with ministry of construction order, have a 1st class licensed architect/building engineer, 2nd class licensed architect/building engineer, or a qualified person as designated by the ministry of construction, periodically inspect the said building equipment, and report the inspection results to the special administrative agency.</p> <p>MOC-N (No.1825-1970) Case specifying persons, etc. having qualifications for periodical inspection of special buildings</p> <p>2. Qualified persons for periodical inspection of elevatory equipment.</p>

EN 115-1 (Europe)	A17.1/B44 (North America)	Japanese codes
<p>7.4.2 Presentation of the instruction handbook</p> <p>a) Type and size of print shall ensure the best possible legibility. Warning signs and/or cautions should be emphasized by the use of colours, symbols, and/or large print.</p> <p>b) Information for use shall be given in the language(s) of the country in which the escalator or moving walk will be used for the first time and in the original version. If more than one language is to be used, each language should be readily distinguished from the other(s) and efforts should be made to keep the translated text and the relevant illustration together.</p> <p>c) Whenever helpful to the understanding, text should be supported by illustrations. Illustrations should be supplemented with written details enabling, for instance, manual controls (actuators) to be located and identified. They should not be separated from the accompanying text and should follow sequential operations.</p> <p>d) Consideration should be given to presenting information in tabular form where this will aid understanding. Tables should be adjacent to the relevant text.</p> <p>e) The use of colours should be considered, particularly in relation to components requiring quick identification.</p> <p>f) When information for use is lengthy, a table of contents and/or an index should be given.</p> <p>g) Safety-relevant instructions which involve immediate action should be provided in a form readily available to the operator.</p>		—

EN 115-1 (Europe)	A17.1/B44 (North America)	Japanese codes
<p>7.4.3 Advice for drafting and editing information for use</p> <p>a) The information shall clearly relate to the specific model of escalator or moving walk.</p> <p>b) When information for use is being prepared, the communication process “see–think–use” should be followed in order to achieve the maximum effect and should follow sequential operations. The questions “how?” and “why?” should be anticipated and the answers provided.</p> <p>c) Information for use shall be as simple and as brief as possible and should be expressed in consistent terms and units with a clear explanation of unusual technical terms.</p> <p>d) Documents giving instructions for use should be produced in durable form (i.e. they should be able to survive frequent handling). It may be useful to mark them “keep for future reference”. Where information for use is kept in electronic form (e.g. CD, DVD, tape), information on safety-related issues that need immediate action shall always be backed up with a hard copy that is readily available.</p>		—
<p>7.5 Marking of escalators and moving walks</p> <p>At least at one landing, the</p> <ul style="list-style-type: none"> - name and full address of the manufacturer and, where applicable, his authorized representative; - designation of series or type of the machinery; - serial number; - year of construction (year in which the manufacturing process is completed) shall be indicated, visible from the outside. 	<p>8.6.1.5 Code data plate</p> <p>8.6.1.5.1 A data plate that indicates the code and edition in effect at the time of installation and any alteration (see 8.7.1.8) shall be provided. The data plate shall also specify the code and edition in effect at the time of any alteration and the applicable requirements of 8.7.</p> <p>8.6.1.5.2 The code data plate shall comply with 8.9.</p> <p>8.9.1 Required information</p> <p>Data plate shall be provided and maintained that shall indicate the code to be used for inspections and tests (see 8.10.1.2). The data plate shall indicate the code and edition in effect at the time of installation. The data plate shall also indicate the code in effect at the time of any alteration and indicate the applicable requirements of 8.7.</p>	—

EN 115-1 (Europe)	A17.1/B44 (North America)	Japanese codes
	<p>8.9.2 Location</p> <p>The data plate shall be in plain view securely attached to the main line disconnect or on the controller. An additional data plate shall be installed in the vicinity of the starting switch on the exterior of escalators and moving walks.</p> <p>8.9.3 Material and construction</p> <p>The data plate shall be of such material and construction that the letters and figures stamped, etched, cast, or otherwise, applied to the face shall remain permanently and readily legible. The height of the letters and figures shall be not less than 3,2 mm (0,125 in.).</p>	
<p>Annex A (normative) — Building interfaces</p> <p>A.1 General</p> <p>The requirements in A.2 and A.3 are important for the safety of users and maintenance personal.</p> <p>If it is not possible for the manufacturers of the escalator or moving walk to fulfill these requirements (or some of them) due to the fact that, e.g. they are not installing the escalator or moving walk, those requirements that are not fulfilled have to be part of the instruction handbook as an obligation for the owner (see 7.4).</p>	—	—

EN 115-1 (Europe)	A17.1/B44 (North America)	Japanese codes
<p>A.2 Free space for users</p> <p>A.2.1 The clear height above the steps of the escalator or pallets or belt of the moving walk at all points shall be not less than 2,30 m (see h_4 in Figure 2 and Figure A.1).</p> <p>NOTE The clear height of 2,30 m should also be applied to the unrestricted area.</p> <p><i>(Figure A.1 — Clearances between building structure and escalator/moving walk units)</i></p>	<p>6.1.3.12/6.2.3.15 Headroom. The minimum headroom shall be 2 130 mm (84 in.) measured vertically from the step noseline/treadway surface, landing plates, and landings.</p>	<p>JIS A 4302-2006</p> <p>5.4.2 Inspection to be carried out on upper and lower landings and on steps.</p> <p>(n) Where dangerous pillars, beams, etc. are located within 0,5 m horizontally from the handrails or 2,1 m above the steps, suitable guards shall be provided.</p> <p>JEAS -A406</p> <p>3. Description</p> <p>3.1.3 On the walls, etc. adjacent to the escalator, partially protruding obstacles (advertisements, lighting fixtures, piping, partition columns, projected walls, etc.) shall not be furnished within a range of 2,100 mm vertically from the nose line of the steps and 500 mm horizontally from the outer face of the handrails (refer to Figure 3).</p>
<p>A.2.2 To prevent collision, a minimum free area around the escalator or moving walk is defined as per Figure A.1. The height, h_{12}, measured from the steps of the escalator or the pallets or the belt of the moving walk shall be at least 2,10 m. The distance between the outer edge of the handrail and walls or other obstacles (see b_{10} in Figure A.1) shall, under no circumstances, be less than 80 mm horizontally and 25 mm vertically below the lower edge of the handrail (see b_{12} in Figure 3). The area is permitted to be smaller, if by appropriate measures, the risk of injury is minimized.</p>	<p>6.1.3.2.2/6.2.3.2.3 Geometry. The handrail shall be a minimum of 100 mm (4 in.) horizontally and 25 mm (1 in.) vertically away from adjacent surfaces, except that rounded fillets or beveled sides of the handrail stand are permitted to reduce the 25 mm (1 in.) clearance between the handrail and the point where the handrail stand is connected to the balustrade. The centerline of the handrail shall be not more than 240 mm (9,5 in.), measured horizontally, from the vertical plane through the edge of the exposed step (see Nonmandatory Appendix I, Figs. I-1 and I-2/Fig. I-9).</p>	<p>—</p>
<p>A.2.3 For escalators arranged adjacent to one another either parallel or criss-cross, the distance between the handrails shall be not less than 160 mm (see b_{11} in Figure A.1).</p>	<p>—</p>	<p>—</p>

EN 115-1 (Europe)	A17.1/B44 (North America)	Japanese codes
<p>A.2.4 Where building obstacles can cause injuries, appropriate preventive measures shall be taken.</p> <p>In particular, at floor intersections and on criss-cross escalators or moving walks, a vertical deflector of not less than 0,30 m in height, not presenting any sharp cutting edges, shall be placed above the handrail level and extend at least 25 mm below the lower edge of the handrail, e.g. as an imperforate triangle (see h_5 in Figures 2 and 4).</p> <p>It is not necessary to comply with these requirements when the distance b_9 between the outer edge of the handrail and any obstacle is equal to or greater than 400 mm (see Figure A.1).</p>	<p>6.1.3.3.11/6.2.3.3.7 Guard at ceiling intersection</p> <p>(a) On high deck balustrades, a solid guard shall be provided in the intersection of the angle of the outside balustrade deck and the ceiling or soffit, under the following conditions:</p> <p>(1) where the clearance between the outside edge of the deck and the ceiling or soffit is 300 mm (121 in.) or less;</p> <p>(2) where the projected intersection of the outside deck and the ceiling or soffit is 600 mm (24 in.) or less from the centerline of the handrail.</p> <p>(b) On low deck balustrades, a solid guard shall be provided to protect the intersection formed by the top of the handrail and the plain of the ceiling or soffit where the centerline of the handrail is 350 mm (14 in.) or less from the ceiling or soffit.</p>	<p>MOC-N (No.1417-2000)</p> <p>1. The construction of escalator devised so as persons or articles not to be caught, not to be collide with obstacles prescribed by BSLJ-EO; Article 129-12 item 1, paragraph 1, shall be specified as in (1), (2), and (3).</p> <p>(3) When the horizontal distance between the outer side of handrail and any obstacle which intersects and close to that outer side of handrail, e.g. the building ceiling, building beam etc. or the lower surface of the adjacent escalator is not greater than 50 cm, a wedge guard should be furnished as follows.</p> <p>(a) The wedge guards should be furnished at lower side of the obstacle.</p> <p>(b) The thickness of the wedge</p>
	<p>(c) The vertical edge of the guard shall be a minimum of 350 mm (14 in.) in length.</p> <p>(d) The escalator/moving walk side of the vertical face of the guard shall be flush with the face of the wellway.</p> <p>(e) The exposed edge of the guard shall present a minimum width of 25 mm (1 in.) and a minimum radius of 12 mm (0,5 in.)</p> <p>(f) Guards are permitted to be of glass or plastic, provided they meet the requirements of 6.1.3.3.3/6.2.3.3.3.</p> <p>See also Nonmandatory Appendix I, Fig. I-5.</p>	<p>guard end should be equal to or greater than 6 mm with no sharp edge. The wedge guard should have construction of the length with which the wedge guard reaches at 20 cm or more, vertically lower than upper surface of the handrail.</p> <p>(c) The wedge guard surface should not differ in rank with the obstacle surface facing the escalator.</p> <p>EXP.1.(3)</p> <p>(Paragraph 1) The wedge guard should be furnished stationary.</p> <p>(Paragraph 2) If the wedge guard could not be fixed on the obstacle because of its construction, the wedge guard might be suspended firmly from the ceiling or beam etc. and its lower side might be fixed to the escalator with chain etc. without big difference in rank with the obstacle surface facing the escalator.</p>

EN 115-1 (Europe)	A17.1/B44 (North America)	Japanese codes
		<p>(Paragraph 4) Vertical surface of the stationary wedge guard facing the escalator is specified not to differ in rank with the obstacle surface facing the escalator. However, it may project at the dimension about a thickness of the wedge guard board or its metal fitting.</p> <p><i>(Paragraph 5) The wedge guard is not required when the obstacle is vertical pillar etc. with no sharp edge.</i></p> <p>EXP.[Notice of designing]</p> <p>2. Wedge guard</p> <p>(1) The stationary wedge guard is effective for preventing the passenger's head from being caught, and its height over the handrail should not be less than 30 cm.</p> <p>(2) The front end of the stationary wedge guard may be a cylinder of 50 mm or more in diameter.</p> <p>(3) It is recommended that a movable wedge guard is furnished in front of the stationary wedge guard to warn the passenger leaning over the handrail of approaching the stationary wedge guard.</p>
—	—	<p>JEAS -A406</p> <p>3. Description</p> <p>3.1 Related matters with floor openings etc. surrounding escalators (to be done by building side)</p> <p>3.1.5 When there is some clearance or space of 200 mm or more between the two adjacent escalators or between the escalator and the opening of the building floor etc., safety nets etc. which do not allow the ball of 50 mm in diameter pass through shall be furnished at every other floor to catch the falling personal belongings of the passengers etc. for preventing injury due to the falling articles.</p> <p>Frameworks of the safety nets etc. shall be made of steel or the like and shall be fixed firmly.</p>

EN 115-1 (Europe)	A17.1/B44 (North America)	Japanese codes
<p>A.2.5 At the exit(s) of each individual escalator or moving walk, a sufficient unrestricted area shall be available to accommodate persons. The width of the unrestricted area shall at least correspond to the distance between the outer edges of the handrails plus 80 mm on each side. The depth shall be at least 2,50 m measured from the end of the balustrade. It shall be permissible to reduce it to 2,00 m if the width of the unrestricted area is increased to at least double the distance between the outer edges of the handrails plus 80 mm on each side.</p>	<p>6.1.3.6.4/6.2.3.8.4 Safety zone. The entry and exit zone shall be kept clear of all obstacles. The width of the zone shall be not less than the width between the centre lines of the handrails plus 200 mm (8 in.). The length of the zone, measured from the end of the newel, shall be no less than twice the distance between the centre lines of the handrails. Space shall be provided to accommodate all traffic in the safety zone.</p>	<p>MOC-N (No. 1417-2000), EXP.2 (notice of designing) 2 $0,5\text{m/s} < V <= 0,75\text{m/s}$ The depth shall be at least 2,50 m measured from the end of the balustrade. $0,5\text{m/s} > = V$</p>
<p>—</p>	<p>6.1.3.6.3/6.2.3.8.3 Adjacent floor surfaces. The adjacent floor surfaces at each landing shall be continuous with the top of the landing plate with no abrupt change in elevation of more than 6 mm (0,25 in.).</p>	<p>—</p>
<p>For succeeding escalators and moving walks, the depth of an unrestricted area shall be determined in each individual case depending on, e.g. type of use (persons only or persons with transport devices, number of intermediate exits, relative orientation, and theoretical capacity).</p>	<p>No equivalent requirement.</p>	<p>—</p>
<p>Where the exit of the escalator or moving walk is blocked by structural measures (e.g. shutters, fire protection gates) an additional stop switch for emergency situations at handrail level (taking into account A.2.2) shall be provided with a distance between 2,0 m and 3,0 m before the step/pallet/belt reaches the comb intersection line. This stop switch shall be reachable from inside the escalator/moving walk.</p>	<p>No equivalent requirement.</p>	<p>—</p>
<p>A.2.6 In the case of successive escalators and moving walks without intermediate exits, they shall have the same capacity (see also h) in Table 6.</p>	<p>—</p>	<p>—</p>

EN 115-1 (Europe)	A17.1/B44 (North America)	Japanese codes
<p>A.2.7 Where it is possible for people to come into contact with the outer edge of a handrail at a landing and can be drawn into a hazardous situation such as toppling over a balustrade, appropriate preventative measures shall be taken (for an example, see Figure A.2).</p> <p>Some examples are the following:</p> <ul style="list-style-type: none"> - prevention of entry into the space by the placement of permanent barriers; - increasing the height of the building structure of the fixed balustrade in the hazard area by at least 100 mm above the handrail level and positioned between 80 mm and 120 mm from the outer edge of the handrail. <p><i>(Figure A.2 — Example of barriers at landings)</i></p>	<p><i>(Defined by building code)</i></p>	<p>JEAS-A 406</p> <p>3. Description</p> <p>3.1 Related matters with floor openings etc. surrounding escalators (to be done by building side)</p> <p>3.1.4 When there is some clearance or space between the escalator and the opening of the building floor, fences for prevention of falling down and barriers for prevention of obstacles falling shall be furnished. At a place facing the entrance or the exit of the escalator, a partition plate shall be furnished to prevent the children from coming in by mistake (refer to Figure 4).</p>
<p>A.2.8 The surrounds of the escalator or moving walk shall be illuminated, especially in the vicinity of the combs.</p> <p>NOTE Information should be exchanged between the manufacturer and the customer.</p>	<p>6.1.7.2/6.2.7.2 Lighting of escalator/treadway. Landing floor plates and all exposed step treads/treadways shall be illuminated with a lighting intensity of not less than 50 lx (5 fc).</p>	<p>—</p>
<p>A.2.9 It is permissible to arrange the lighting in the surrounding space or at the installation itself. The intensity of illumination at the landings, including the combs, shall be related to the intensity of illumination of the general lighting in the area. The intensity shall be not less than 50 lx at the comb intersection line measured at floor level.</p>	<p>The illumination of these surfaces shall be of uniform intensity and not contrast materially with that of the surrounding area.</p>	<p>—</p>
<p>A.3 Machinery spaces outside the truss</p> <p>A.3.1 A safe access for persons to machinery spaces shall be provided.</p>	<p>(A17.1/B44 does not address this issue. Words like “easy and safe” should be avoided in a code rule. They are subjective and provide no frame of reference to design or inspect to).</p>	<p>—</p>
<p>A.3.2 Machinery spaces shall be lockable and only accessible to authorized persons (see EN 13015:2001, 4.3.2.13).</p>	<p>6.1.7.3.2 Access plates at the top and bottom landings shall be securely fastened by a mechanical means.</p>	<p>—</p>

EN 115-1 (Europe)	A17.1/B44 (North America)	Japanese codes
<p>A.3.3 Machinery spaces shall be provided with permanently installed electric lighting on the following basis:</p> <p>a) a minimum of 200 lx at floor level in working areas;</p> <p>b) a minimum of 50 lx at floor level in access routes leading to these working areas.</p>	<p>6.1.7.1.1/6.2.7.1.1 Remote machine room. Permanent electric lighting and a duplex receptacle rated at not less than 15 A, 120 V shall be provided in every remote machine room.</p> <p>The illumination shall be not less than 100 lx (10 fc) at the floor level. The lighting control switch shall be located within easy reach of the access to such rooms and so located that it can be operated without passing or reaching over any part of the machinery.</p>	—
<p>A.3.4 Emergency lighting shall be installed to allow the safe evacuation of all personnel working in any machinery space.</p> <p>NOTE Emergency lighting is not intended for continuation of maintenance or other activities.</p>	—	—
<p>A.3.5 The dimensions of machinery spaces shall be sufficient to permit easy and safe working on equipment, especially the electrical equipment.</p> <p>In particular, there shall be provided at least a clear height of 2,00 m at working areas and</p> <p>a) a clear horizontal area in front of the control panels and the cabinets. This area is defined as follows:</p> <p>1) depth, measured from the external surface of the enclosures at least 0,70 m;</p> <p>2) width, the greater of the following values 0,50 m or the full width of the cabinet or panel;</p> <p>b) a clear horizontal area of at least 0,50 m × 0,60 m for maintenance and inspection of moving parts at points where this is necessary.</p>	<p>Rules from 1996 Edition ANSI/NFPA 70:</p> <p>620-5 Working clearances. Working space shall be provided about controllers, disconnecting means, and other electrical equipment. The minimum working space shall not be less than specified in Section 110-16 (a).</p> <p>Where conditions of maintenance and supervision ensure that only qualified persons will examine, adjust, service, and maintain the equipment, the clearance requirements of section 110-16 (a) shall be waived as permitted in (a) through (d) below.</p> <p>(a) Flexible connections to equipment. Electrical equipment in (1) through (4) below is provided with flexible leads to all external connections:</p> <p>(1) Controllers and disconnecting means for dumbwaiters, escalators, moving walks, wheelchair lifts, and stairway chair lifts installed in the same space with the driving machine.</p>	—

EN 115-1 (Europe)	A17.1/B44 (North America)	Japanese codes
	<p>(b) Guards. Live parts of the electrical equipment are suitably guarded, isolated, or insulated and the equipment can be examined, adjusted, serviced, or maintained while energized without removal of this protection.</p> <p>(FPN): See definition for “Exposed” in Article 100.</p> <p>(c) Examination, adjusting, and servicing. Electrical equipment is not required to be examined, adjusted, serviced, or maintained while energized.</p> <p>(d) Low voltage. Uninsulated parts are at a voltage no greater than 30 V RMS, 42 V peak, or 60 V dc.</p> <p>620-4. Live parts enclosed. All live parts of electric apparatus in the hoistways, at the landings, or in or on the cars of elevators and dumbwaiters, or in the wellways or the landings of escalators or moving walks, or in the runways and machinery spaces of wheelchair lifts and stairway chair lifts shall be enclosed to protect against accidental contact.</p> <p>(FPN): See Section 110-17 for guarding of live parts (600 V, nominal, or less).</p>	
<p>A.3.6 The clear height for movement shall not be less than 1,80 m.</p> <p>The access ways to the clear spaces mentioned in A.3.6 shall have a width of at least 0,50 m. This value may be reduced to 0,40 m where there are no moving parts.</p> <p>This full height for movement is taken to the underside of the structural roof beams and measured from both</p> <p>a) the floor of the access area, and</p> <p>b) the floor of the working area</p>	<p>—</p>	<p>—</p>
<p>A.3.7 In machinery spaces the clear height shall under no circumstances be less than 2,0 m.</p>	<p>—</p>	<p>—</p>

EN 115-1 (Europe)	A17.1/B44 (North America)	Japanese codes
—	<p>6.1.3.15 Pit drains. Permanent provisions shall be made to prevent accumulation of water in the pit. Drains and sump pumps, where provided, shall comply with 2.2.2.4.</p> <p>2.2.2.4 Drains and sump pumps, where provided, shall comply with the applicable plumbing code and they shall be provided with a positive means to prevent water, gases, and odors from entering the hoistway.</p>	—
<p>A.4 Electric power supply</p> <p>Agreements shall be made between the owner and the manufacturer about electric supply and electric protection requirements (e.g. electric shock, short circuit, overload).</p> <p>The installation shall comply with</p> <p>a) EN 60204-1, or</p> <p>b) with the requirements of the national rules of the country where it is installed.</p>	—	—
<p>D.4 Mechanical tests</p> <p>D.4 1 General</p> <p>During the tests, the tested object (printed circuit) shall be kept under operation. During and after the tests, no unsafe operation and condition shall appear within the fail safe circuit.</p> <p>D.4.2 Vibrations</p> <p>Transmitter elements of fail safe circuits shall withstand the requirements of the following:</p> <p>a) EN 60068-2-6 1995, A.6.1, Table C.2 (Endurance by sweeping: 20 sweep cycles in each axis);</p> <p>1) at amplitude 0,35 mm or 5 gn;</p> <p>2) and in the frequency range 10 Hz to 55 Hz and also of</p>	—	—

EN 115-1 (Europe)	A17.1/B44 (North America)	Japanese codes																			
<p>b) EN 60068-2-27 1993, 4.1, Table 1 (acceleration and duration of pulse) in the combination of</p> <p>1) peak acceleration 294 m/s² or 30 g_n; 2) corresponding duration of pulse 11 ms; 3) corresponding velocity change 2,1 m/s half sine.</p> <p>NOTE Where shock absorbers for the transmitter elements are fitted, they are considered as part of the transmitter elements.</p> <p>After tests, clearances and creeping distances shall not become smaller than the minimum accepted.</p>																					
<p>Annex H (informative) Guidelines for selection and planning of escalators and moving walks</p> <p>H.1 Maximum capacity</p> <p>For traffic flow planning, the maximum number of persons that can be carried by an escalator or moving walk in 1 h is given in Table H.1.</p> <table border="1" data-bbox="108 1223 523 1406"> <thead> <tr> <th rowspan="2">Width m</th> <th colspan="3">Nominal Speed m/s</th> </tr> <tr> <th>0,50</th> <th>0,65</th> <th>0,75</th> </tr> </thead> <tbody> <tr> <td>0,60</td> <td>4 500 pers/h</td> <td>5 850 pers/h</td> <td>6 750 pers/h</td> </tr> <tr> <td>0,80</td> <td>6 750 pers/h</td> <td>8 775 pers/h</td> <td>10 125 pers/h</td> </tr> <tr> <td>1,00</td> <td>9 000 pers/h</td> <td>11 700 pers/h</td> <td>13 500 pers/h</td> </tr> </tbody> </table>	Width m	Nominal Speed m/s			0,50	0,65	0,75	0,60	4 500 pers/h	5 850 pers/h	6 750 pers/h	0,80	6 750 pers/h	8 775 pers/h	10 125 pers/h	1,00	9 000 pers/h	11 700 pers/h	13 500 pers/h	<p>Capacity (see rated load).</p>	<p>BSLJ-EO; Article 129-12</p> <p>EXP.1.(4) Notice of designing</p> <p>The official transportation capacity is assumed to be a table below according to rated speed.</p> <p>The official transportation capacity is maximum number which is capable of transportation theoretically, In case of escalator, the transportation number is one person/step for the S600 type, two person/step for the S1000 type.</p> <p>In case of moving walk, the transportation number is one person for the S600 type, two person for the S1000 type per the 400 mm length which is equivalent to the depth dimension of escalator step.</p> <p>An actual number of transportation is the number of people by which the boarding rate is multiplied for the official transportation ability. Generally, the boarding rate is about 50 % on average though temporarily reaches 80 % in transit system.</p>
Width m		Nominal Speed m/s																			
	0,50	0,65	0,75																		
0,60	4 500 pers/h	5 850 pers/h	6 750 pers/h																		
0,80	6 750 pers/h	8 775 pers/h	10 125 pers/h																		
1,00	9 000 pers/h	11 700 pers/h	13 500 pers/h																		

EN 115-1 (Europe)	A17.1/B44 (North America)	Japanese codes																				
<p>H.2 Escalators or moving walks for public transport</p> <p>For escalators or moving walks which</p> <ul style="list-style-type: none"> - are part of a public transport system including entrance and exit points, or - are suitable for intensive use, regularly operating for approximately 140 h/week with a load reaching 100 % of the brake load (see 5.4.2.1.3.1 and 5.4.2.1.3.3) for a total duration of at least 0,5 h during any time interval of 3 h, it is recommended to install auxiliary brakes also for rise, s_{h13}, less than 6 m. <p>The load conditions and additional safety features should be agreed between the manufacturer and the owner reflecting the traffic levels which exist.</p>		<p>Generally, two kinds of the escalator with step width of 600 mm (past 800 type) and 1000 mm (past 1200 type) are available. They are called as S600 type and S1000 type.</p> <table border="1" data-bbox="1139 472 1426 741"> <thead> <tr> <th rowspan="2">speed</th> <th colspan="2">persons/h</th> </tr> <tr> <th>S600</th> <th>S1000</th> </tr> </thead> <tbody> <tr> <td>20 m/min</td> <td>3 000</td> <td>6 000</td> </tr> <tr> <td>30 m/min</td> <td>4 500</td> <td>9 000</td> </tr> <tr> <td>40 m/min</td> <td>6 000</td> <td>12 000</td> </tr> <tr> <td>45 m/min</td> <td>6 750</td> <td>13 500</td> </tr> <tr> <td>50 m/min</td> <td>7 500</td> <td>15 000</td> </tr> </tbody> </table>	speed	persons/h		S600	S1000	20 m/min	3 000	6 000	30 m/min	4 500	9 000	40 m/min	6 000	12 000	45 m/min	6 750	13 500	50 m/min	7 500	15 000
speed	persons/h																					
	S600	S1000																				
20 m/min	3 000	6 000																				
30 m/min	4 500	9 000																				
40 m/min	6 000	12 000																				
45 m/min	6 750	13 500																				
50 m/min	7 500	15 000																				

EN 115-1 (Europe)	A17.1/B44 (North America)	Japanese codes
<p>Annex I (informative) Requirements on escalators and moving walks intended to transport shopping trolleys and baggage carts</p> <p>I.1 Escalators</p> <p>The use of both shopping trolleys and baggage carts on escalators is unsafe and shall not be permitted.</p> <p>The principle reasons why the use of these products is considered to be unsafe are foreseeable misuse, overloading, and width restriction.</p> <p>Where shopping trolleys and/or baggage carts are available in the area around escalator installations, suitable barriers shall be provided to prevent access.</p> <p>NOTE If safe means of transportation, i.e. shopping trolleys or baggage carts are available to be used on escalators than special measures should be defined between the manufacturer of the escalator, the manufacturer of the means of transportation, and the customer based on risk assessment in accordance with</p>	<p>SCOPE</p> <p>This part applies to escalators/ moving walks used to transport passengers.²⁾</p> <p><i>2) The A17.1/B44 code addresses safety for escalators as described in the Scope. It is not intended to apply to material conveyers. Carrying carts, wheelchairs, or other wheeled carriages is discouraged because of the hazards they represent to passengers and the damage they can cause to the equipment that compromise safety.</i></p>	<p>Commentary:</p> <p><u>1. The present situation of wheelchair escalator</u></p> <p>The time is getting ripe for repletion of social welfare and there is a great need in Japan for installation of elevatory equipment for wheelchair users at the public institutions, (stations, city halls, public halls, etc.). With regard to escalator for wheelchair, there are at present approx. 600 sets operating in Japan.</p> <p>Especially, there is a steady increase in a demand of escalator for wheelchair in existing stations because of a merit of installation space and transport capacity.</p> <p>Recently, the need of escalator for wheelchair is shifting to the one which is able to carry an electric wheelchair from the conventional manual type.</p> <p>In the meantime, “A guideline to development of escalator at a railway station (1991)” was issued by ministry of transport and installation of escalator for wheelchair is promoted.</p>

EN 115-1 (Europe)	A17.1/B44 (North America)	Japanese codes
<p>ISO/TS 14798. Outline guidance is given as follows:</p> <p>Shopping trolleys or baggage carts which are chosen for use on an escalator must be specified between the shopping trolley or baggage cart manufacturer and the escalator manufacturer. If non-specified shopping trolleys or baggage carts are available in the escalator area, there is a serious risk of misuse. It is necessary to prevent access to the escalator entrance.</p> <p>The width of the shopping trolley or baggage cart and its contents should be at least 400 mm less than the nominal step width. Passengers should be able to leave the escalator, even if shopping trolleys or baggage carts are on the escalator.</p> <p>The escalators should be supplied with a horizontal step run of 1,6 m at both landing areas, minimum transition radii of 2,6 m at the upper landing and 2,0 m at the lower landing and limiting the rated speed to 0,5 m/s and the inclination to 30°.</p> <p>Combs should be designed with an angle β of max. 19° combined with a diameter of the shopping trolley or baggage cart roller of at least 120 mm diameter.</p> <p>Additional stops for emergency situations at handrail level (taking into account A.2.2) with a distance between 2,0 m and 3,0 m before the step reaches the comb intersection line should be provided. The stop for emergency situations near the transition curve should be reachable from inside the escalator and the stops for emergency situations at exit(s) shall be reachable from outside of the escalator.</p> <p>Shopping trolleys or baggage carts should conform to the escalator design.</p> <ul style="list-style-type: none"> - The shopping trolley or baggage cart design should ensure a safe and correct loading. - The maximum weight for a shopping trolley or baggage cart should be 160 kg when loaded. 		<p>As there is no law or regulation for wheelchair escalator, escalator manufacturers are getting approval from the Building Center of Japan (BCJ) which is an affiliate of MOC to cope with the situation.</p> <p>This the figure for 1996</p> <p><u>2. The present situation for carrying trolley, baby cart, etc. on escalators</u></p> <p>There is no law or regulation regarding use of trolley or baby cart on ordinary escalators.</p> <p>Carrying trolley, baby cart, etc. on escalators is warned against use of them by „Caution label“ for reasons of safety and elevators are recommended in general for the purpose.</p> <p>MOC-N (No.1417-2000)</p> <p>1. The construction of escalator devised so as persons or articles not to be caught, not to be collide with obstacles prescribed by BSLJ-EO; Article 129-12, item 1, paragraph 1 shall be specified as in (1), (2), and (3).</p> <p>However, (1) and (2) shall not apply to the escalator providing following conditions.</p> <ul style="list-style-type: none"> - 2 or more steps are kept in the same level of tread surface when the escalator carries the person sitting on wheelchair. - The rated speed in that operation does not exceed 30 m/min. - Stoppers for the wheels are furnished on the tip of that levelled tread surface. <p>(1) The clearance between the steps and the skirt guard panel should not exceed 5 mm.</p> <p>(2) The clearance between the adjacent steps should not exceed 5 mm.</p> <p>(3) When the horizontal distance between the outer side of handrail and any obstacle which intersects and close to that outer side of handrail, e.g. the building ceiling, building beam etc., or the lower surface of the adjacent escalator is not greater than 50 cm, a wedge</p>

EN 115-1 (Europe)	A17.1/B44 (North America)	Japanese codes
<p>- Shopping trolley or baggage cart should automatically lock themselves on the inclined part of escalators.</p> <p>- Shopping trolley or baggage cart should be fitted with a braking or blocking system.</p> <p>- Shopping trolley or baggage cart should have deflectors (bumpers) to reduce the risk of clamping.</p> <p>- For safe exit from the escalator, it is necessary that the rear rollers of the shopping trolley or baggage cart are able to push the front rollers over the comb. The front rollers and/or blocking system should easily release from the steps.</p> <p>- Deflectors and guiding devices should be added to the surrounding area to ensure correct alignment of shopping trolley or baggage cart when entering the escalator.</p> <p>- Safety signs about safe and correct use of the shopping trolley or baggage cart should be added.</p> <p>I.2 Moving walks</p> <p>The use of suitably designed shopping trolleys (according to EN 1929-2 and EN 1929-4) and baggage carts on moving walks is permitted.</p> <p>Shopping trolleys or baggage carts which are chosen for use on a moving walk shall be specified between the baggage cart manufacturer and the moving walk manufacturer. If non-specified shopping trolleys or baggage carts are available in the moving walk area, there is a serious risk of misuse. It is necessary to prevent access to the moving walk entrance.</p> <p>The width of the shopping trolley or baggage cart and its contents shall be at least 400 mm less than the nominal pallet/belt width. Passengers shall be able to leave the moving walk, even if shopping trolleys or baggage carts are on the moving walk.</p> <p>For moving walks with an inclination greater than 6°, the rated speed shall be limited to 0,5 m/s.</p>		<p>guard should be furnished as follows.</p> <p>(a) The wedge guards should be furnished at lower side of the obstacle.</p> <p>(b) The thickness of the wedge guard end should be equal to or greater than 6 mm with no sharp edge. The wedge guard should have construction of the length with which the wedge guard reaches at 20 cm or more, vertically lower than upper surface of the handrail.</p> <p>(c) The wedge guard surface should not differ in rank with the obstacle surface facing the escalator.</p> <p>EXP.1. The escalator of this notification includes moving walks and escalator for person sitting on wheelchair. Because only the person sitting on wheelchair rides on these special steps, the specification (1) and (2) shall not apply.</p> <p>EXP. [Notice of designing]</p> <p>1. Escalator with steps for wheelchair</p> <p>(1) Only the attendant of the building manager should be allowed to handle the wheelchair and operate the escalator carrying wheelchair.</p> <p>(2) The effective distance between the interior panels of balustrade should be approx. 1,2 m.</p> <p>(3) The speed of the escalator should become zero or very slow when the person sitting on wheelchair gets on/off the escalator.</p> <p>(4) Operation panels should be furnished at the upper and lower landings. Emergency stop switch(es) which is effective in wheelchair carrying operation shall be furnished in intermediate section if necessary.</p> <p>(5) It is recommended that an interphone is furnished near the landing for requesting the wheelchair operation to the attendant of the building manager.</p>

EN 115-1 (Europe)	A17.1/B44 (North America)	Japanese codes
<p>Combs shall be designed with an angle β of max. 19° combined with a diameter of the shopping trolley or baggage cart roller of at least 120 mm diameter.</p> <p>Additional stops for emergency situations at handrail level (taking into account A.2.2) with a distance between 2,0 m and 3,0 m before the pallet reaches the comb intersection line shall be provided. The stop for emergency situations near the transition curve shall be reachable from inside the moving walk and the stops for emergency situations at exit(s) shall be reachable from outside of the moving walk.</p> <p>Shopping trolleys or baggage carts shall conform to the moving walk design.</p> <ul style="list-style-type: none"> - The shopping trolley or baggage cart design shall ensure a safe and correct loading. - The maximum weight for a shopping trolley or baggage cart shall be 160 kg when loaded. - Shopping trolley or baggage cart shall automatically lock themselves on the inclined part of moving walks. - Shopping trolley or baggage cart shall be fitted with a braking or blocking system. - Shopping trolley or baggage cart shall have deflectors (bumpers) to reduce the risk of clamping. - For safe exit from the moving walk, it is necessary that the rear rollers of the shopping trolley or baggage cart are able to push the front rollers over the comb. The front rollers and/or blocking system shall easily release from the pallet. - Deflectors and guiding devices shall be added to the surrounding area to ensure correct alignment of shopping trolley or baggage cart when entering the moving walk. - Safety signs about safe and correct use of the shopping trolley or baggage cart should be added. 		

Annex A
(informative)

Figures of EN 115-1

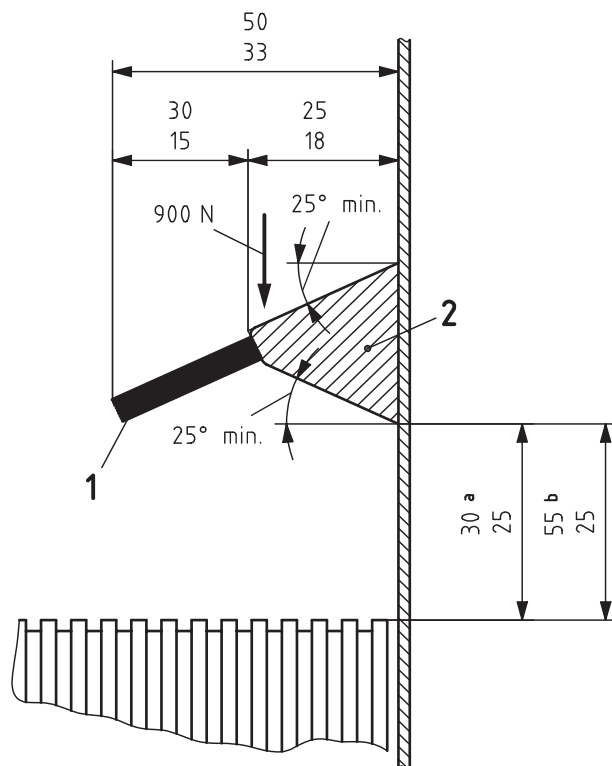

Figure A.1 — Requirements on skirt deflectors (EN 115-1, Figure 1)

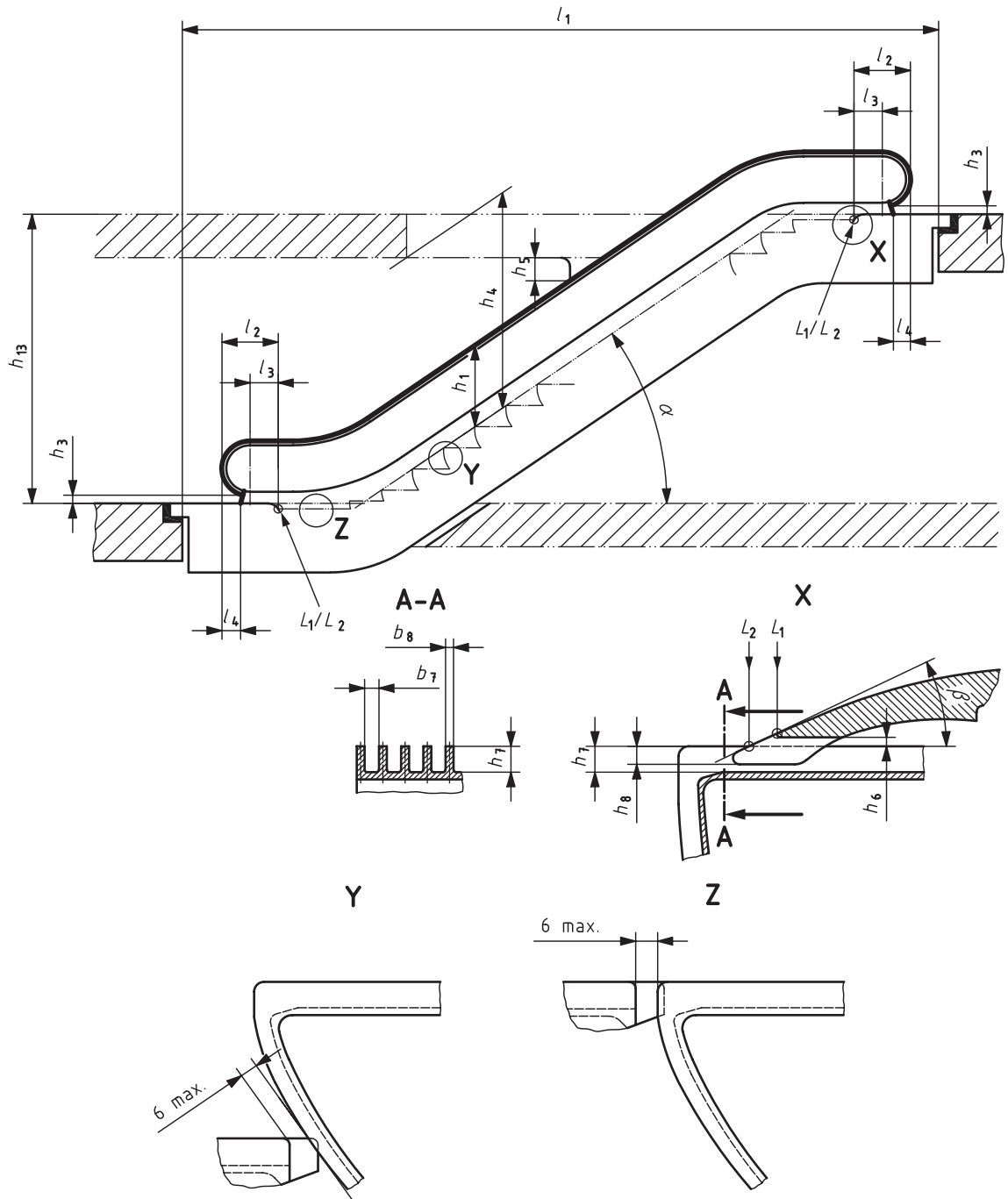
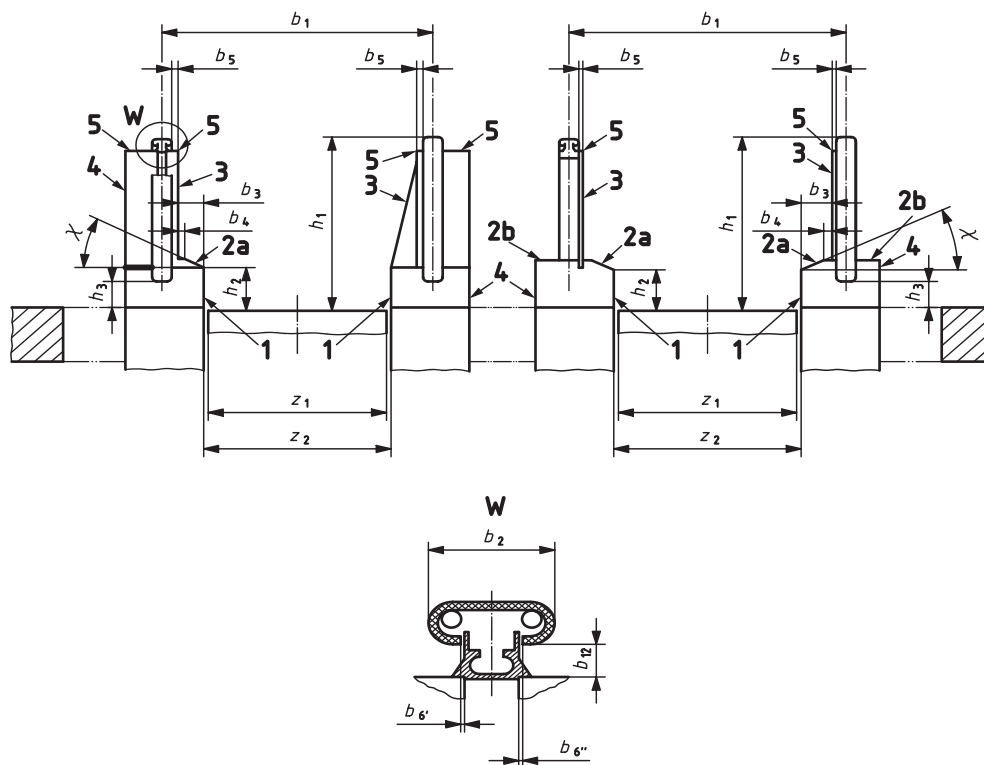

Figure A.2 — Escalator (elevation), principal dimensions (EN 115-1, Figure 2)



Key

- | | | | |
|----|-------------------------------|---|------------------------------|
| 1 | skirting (5.5.3) | 3 | interior panel (5.5.2.4) |
| 2a | lower inner decking (5.5.2.6) | 4 | exterior panel (5.2.1.2) |
| 2b | lower outer decking (5.5.2.2) | 5 | balustrade decking (5.5.2.2) |

Figure A.3 — Escalator/moving walk (sectional view), principal dimensions (EN 115-1, Figure 3)

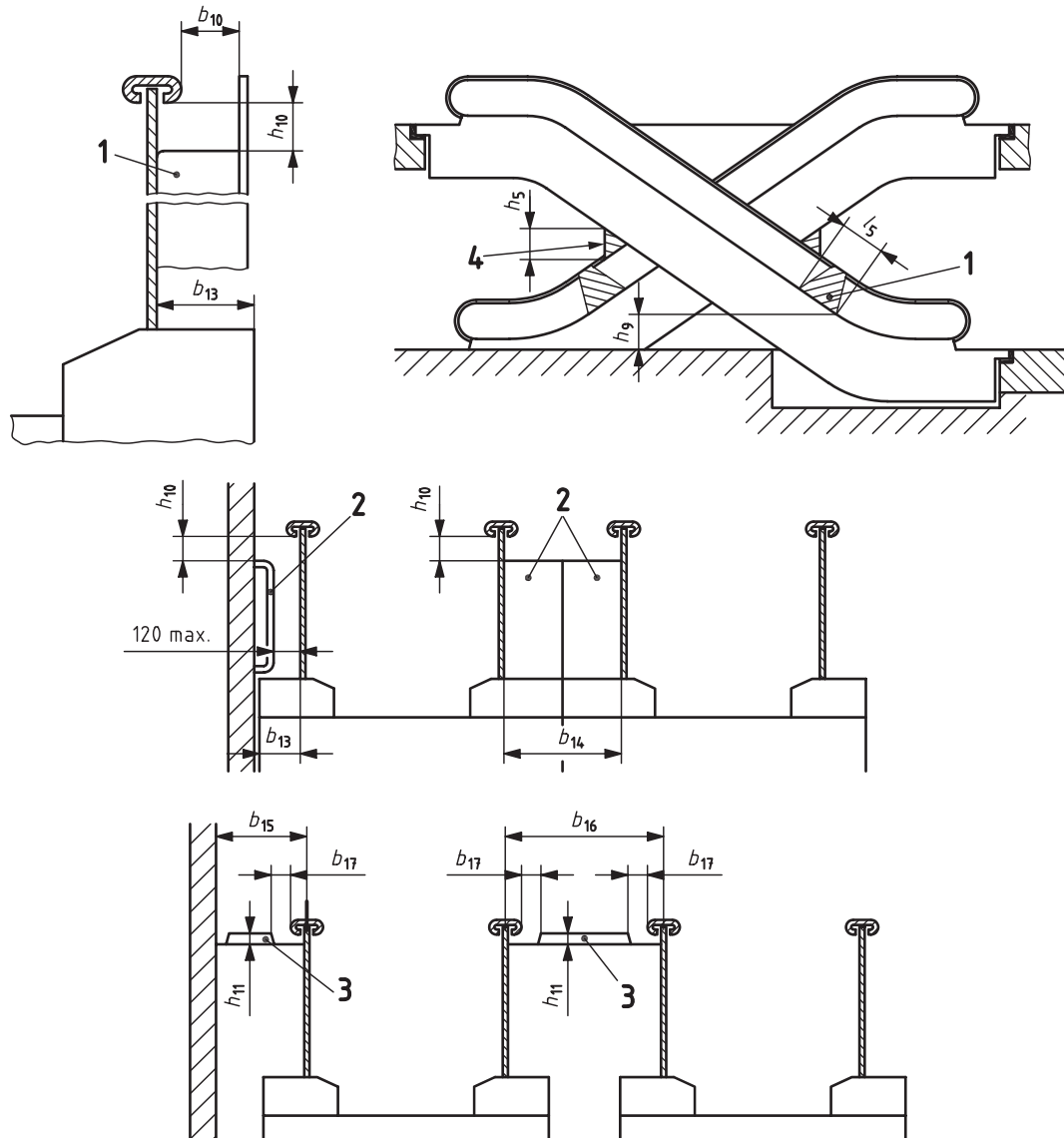

Key

- | | | | |
|---|-------------------------------------|---|-----------------------------|
| 1 | anti-climbing device (5.5.2.2) | 3 | anti-slide device (5.5.2.2) |
| 2 | access restriction device (5.5.2.2) | 4 | vertical deflector (A.2.4) |

Figure A.4 — Anti-misuse devices (EN 115-1, Figure 4)

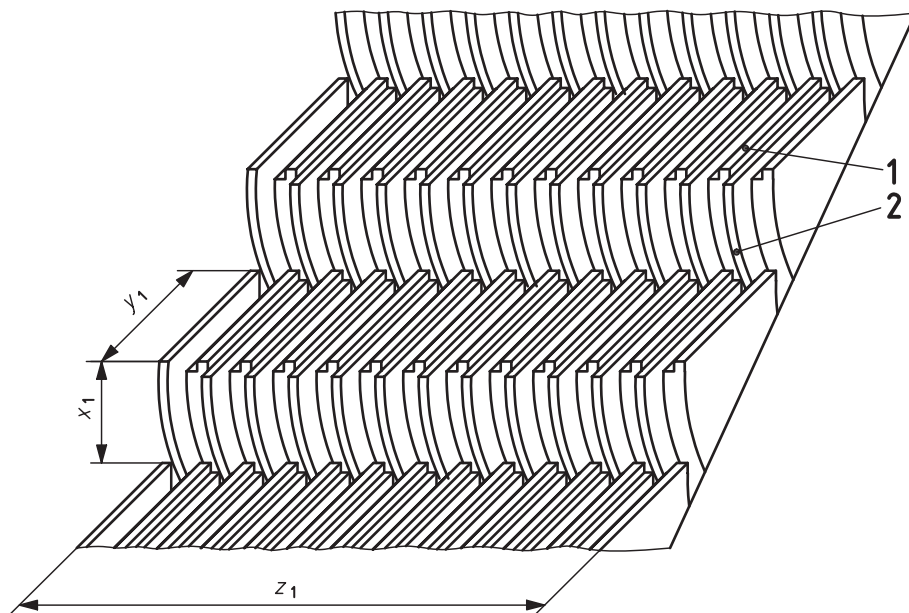

Key

- 1 step treads
- 2 step risers

Figure A.5 — Steps, principal dimensions (EN 115-1, Figure 5)

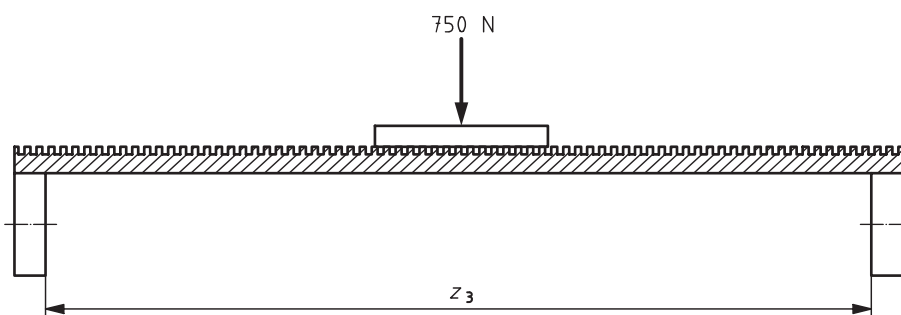
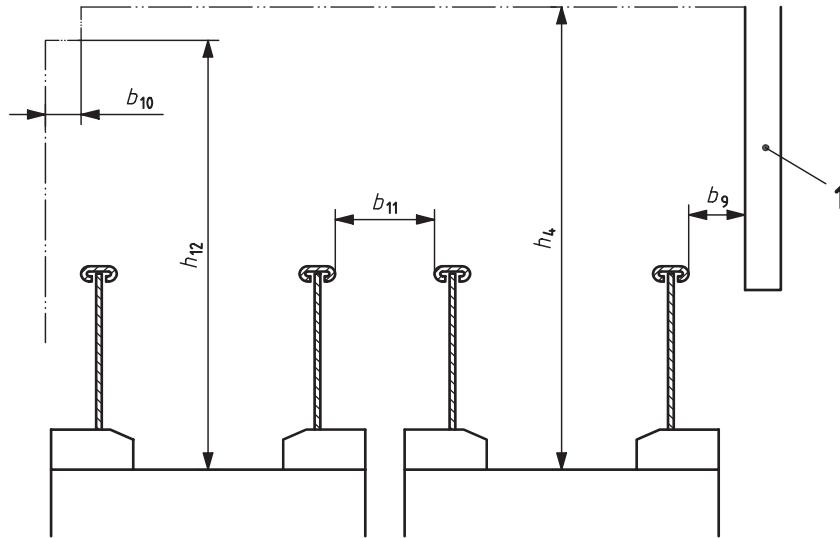

Figure A.6 — Belt (sectional view), single force (EN 115-1, Figure 8)



Key

1 obstacle (e.g. column)

Figure A.7 — Clearances between building structure and escalator/moving walk (EN 115-1, Figure A.1)

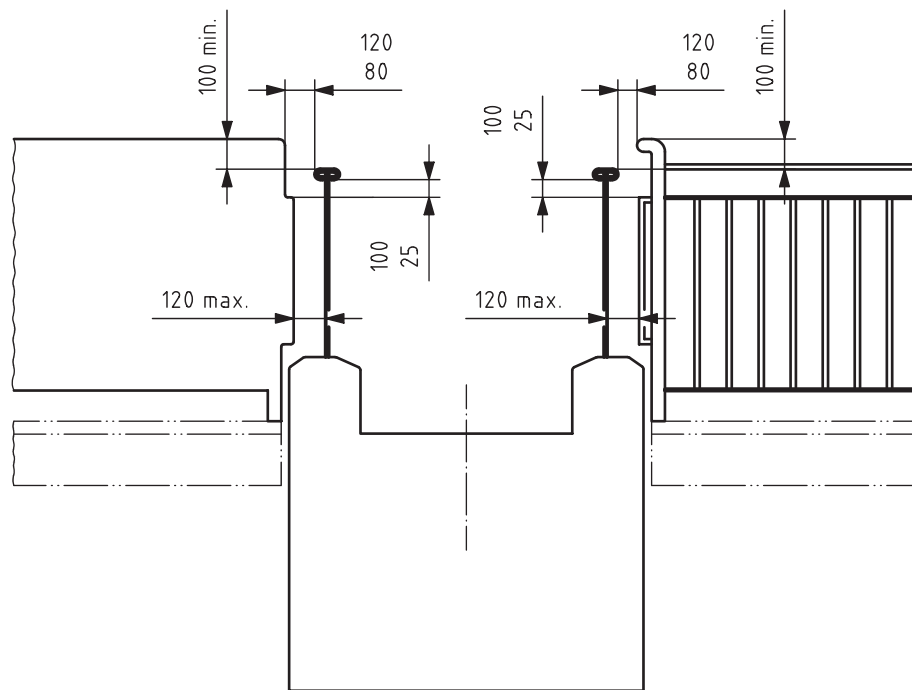

Figure A.8 — Example of barriers at landings (EN 115-1, Figure A.2)

Annex B (informative)

Tables mentioned in the column for Japanese codes

Table B.1

The title and the parts except enumeration of each item of paragraph 1, the title of paragraph 2, and paragraph 3 of article 129-4, and the title and paragraph 1 of Article 129-5	Elevator	Escalator
Article 129-4	Car	Step
Article 129-4 paragraph 1, item 2	Elevator of which car suspended by main ropes, oil hydraulic elevator, and other elevators designated by the minister of land, infrastructure, and transport	Escalator of which steps suspended by chain and other escalators designated by the minister of land, infrastructure, and transport
Article 129-4 paragraph, 1, item 2 and paragraph 2	Strength verification method for elevator	Strength verification method for escalator
Article 129-4 paragraph, 2, item 1	following article	Paragraph 1 of following article and Article 129-12, paragraph 3
Article 129-4 paragraph 2, item 2	Load provided by paragraph 2 of following Article	Load provided by Article 129-12, paragraph 3

Table B.2

Imaging load condition	Formula
Normal condition	$G_1 + X_1(G_2 + P)$
Safety device is actuated	$G_1 + X_2(G_2 + P)$

Table B.3

	Safety factor at normal operation	Safety factor when safety device is actuated
Steel materials in steel construction	3.0	2.0

Table B.4

	Safety factor at normal operation		Safety factor when safety device is actuated	
	At installation	During use	At installation	During use
Chain to suspend the step, other similar equipment, and hitch part	7,0	4,0	2,5	2,5
belt	7,0	4,0	4,0	2,5

Table B.5

	Critical safety factor at installation	Critical safety factor during use
Chain to suspend the step, other similar equipment, and hitch part	2,5	2,5
Belt	4,0	2,5

Table B.6

Inclination (degree)		Rated speed(m/min)
Exceeding 30~ up to 35	Escalator	30 and less

Table B.7

Inclination (degree)		Rated speed(m/min)
Exceeding 8~ up to 30	Escalator	45 and less

Table B.8

Inclination (degree)		Rated speed(m/min)
Up to 8	Moving walk	50 and less
Exceeding 8~ up to 15		45 and less

Annex C (informative)

References in the compared codes

C.1 References in EN 115-1

EN 1929-2, *Basket trolleys — Part 2: Requirements, tests and inspection for basket trolleys with or without a child carrying facility, intended to be used on passenger conveyors*

EN 1929-4, *Basket trolleys — Part 4: Requirements and tests for basket trolleys with additional goods carrying facility(ies), with or without a child carrying facility, intended to be used on passenger conveyors*

EN 1993-1-1, *Eurocode 3: Design of steel structures — Part 1-1: General rules and rules for buildings*

EN 10025-1, *Hot rolled products of structural steels — Part 1: General technical delivery conditions*

EN 10025-2, *Hot rolled products of structural steels — Part 2: Technical delivery conditions for non-alloy structural steels*

EN 10025-3, *Hot rolled products of structural steels — Part 3: Technical delivery conditions for normalized/normalized rolled weldable fine grain structural steels*

EN 10025-4, *Hot rolled products of structural steels — Part 4: Technical delivery conditions for thermomechanical rolled weldable fine grain structural steels*

EN 10025-5, *Hot rolled products of structural steels — Part 5: Technical delivery conditions for structural steels with improved atmospheric corrosion resistance*

EN 10025-6, *Hot rolled products of structural steels — Part 6: Technical delivery conditions for flat products of high yield strength structural steels in the quenched and tempered condition*

EN 10083-1, *Steels for quenching and tempering — Part 1: General technical delivery conditions*

EN 10083-2, *Steels for quenching and tempering — Part 2: Technical delivery conditions for non alloy steels*

EN 10083-3, *Steels for quenching and tempering — Part 3: Technical delivery conditions for alloy steels*

EN 12015, *Electromagnetic compatibility — Product family standard for lifts, escalators and moving walks — Emission*

EN 12016, *Electromagnetic compatibility — Product family standard for lifts, escalators and moving walks — Immunity*

EN 13015:2001, *Maintenance for lifts and escalators — Rules for maintenance instructions*

EN 13501-1:2007, *Fire classification of construction products and building elements — Part 1: Classification using data from reaction to fire tests*

EN 60068-2-6:1995, *Environmental testing — Part 2: Tests — Tests Fc: Vibration (sinusoidal) (IEC 60068-2-6:1995 + Corrigendum 1995)*

EN 60068-2-14, *Environmental testing — Part 2: Tests — Test N: Change of temperature (IEC 60068-2-14:1984 + A1:1986)*

EN 60068-2-27:1993, *Basic environmental testing procedures — Part 2: Tests — Test Ea and guidance: Shock (IEC 60068-2-27:1987)*

- EN 60068-2-29, *Basic environmental testing procedures — Part 2: Tests; Test Eb and guidance: Bump* (IEC 60068-2-29:1987)
- EN 60204-1:2006, *Safety of machinery — Electrical equipment of machines — Part 1: General requirements* (IEC 60204-1:2005, modified)
- EN 60269-1, *Low-voltage fuses — Part 1: General requirements* (IEC 60269-1:2006)
- EN 60439-1:1999, *Low-voltage switchgear and controlgear assemblies — Part 1: Type-tested and partially type-tested assemblies* (IEC 60439 1:1999)
- EN 60529, *Degrees of protection provided by enclosures (IP code)* (IEC 60529:1989)
- EN 60664-1:2007, *Insulation coordination for equipment within low-voltage systems — Part 1: Principles, requirements and tests* (IEC 60664-1:2007)
- EN 60947-4-1, *Low-voltage switchgear and controlgear — Part 4-1: Contactors and motor-starters; Electromechanical contactors and motor-starters* (IEC 60947-4-1:2000)
- EN 60947-5-1, *Low-voltage switchgear and controlgear - Part 5-1: Control circuit devices and switching elements — Electromechanical control circuit devices* (IEC 60947-5-1:2003)
- EN 61249 series, *Materials for printed boards and other interconnecting structures* (IEC 61249 series)
- EN 61558-1:2005, *Safety of power transformers, power supplies, reactors and similar products — Part 1: General requirements and tests* (IEC 61558-1:2005)
- EN 62061, *Safety of machinery — Functional safety of safety-related electrical, electronic and programmable electronic control systems* (IEC 62061:2005)
- EN 62326-1, *Printed boards — Part 1: Generic specification* (IEC 62326-1:2002)
- ISO 12100-1:2003, *Safety of machinery — Basic concepts, general principles for design — Part 1: Basic terminology, methodology* (ISO 12100-1:2003)
- ISO 12100-2:2003, *Safety of machinery — Basic concepts, general principles for design — Part 2: Technical principles* (ISO 12100-2:2003)
- ISO 13850, *Safety of machinery — Emergency stop — Principles for design* (ISO 13850:2006)
- ISO 13857:2006, *Safety of machinery — Safety distances to prevent hazard zones being reached by the upper and lower limbs* (ISO 13857:2008)
- ISO 3864-1, *Graphical symbols — Safety colours and safety signs - Part 1: Design principles for safety signs in workplaces and public areas (Note: Corrected and reprinted in 2003-12)*
- ISO 3864-3, *Graphical symbols — Safety colours and safety signs — Part 3: Design principles for graphical symbols for use in safety signs*
- HD 21.3 S3, *Polyvinyl chloride insulated cables of rated voltages up to and including 450/750 V — Part 3: Non-sheathed cables for fixed wiring* (IEC 60227-3:1993, modified)
- HD 21.4 S2, *Polyvinyl chloride insulated cables of rated voltages up to and including 450/750 V — Part 4: Sheathed cables for fixed wiring*
- HD 21.5 S3, *Polyvinyl chloride insulated cables of rated voltages up to and including 450/750 V — Part 5: Flexible cables (cords)* (IEC 60227-5:1979, modified)
- HD 22.4 S4, *Cables of rated voltages up to and including 450/750 V and having crosslinked insulation — Part 4: Cords and flexible cables*
- HD 60364-4-41, *Low-voltage electrical installations — Part 4-41: Protection for safety — Protection against electric shock* (IEC 60364- 4-41:2005, modified)

IEC 60747-5-5, *Semiconductor devices — Discrete devices — Part 5-5: Optoelectronic devices — Photocouplers* (NOTE: This standard is intended to be published unmodified as an EN 60747-5-5.)

C.2 References in A17.1/B44

CAN/CSA-B44.1/ASME A17.5-M 1991, *Standard for Elevator and Escalator Electrical Equipment*.

ASME A17.2.3, *Inspectors' Manual for Escalators and Moving Walks*.

ASME A17.3 (latest edition), *Safety Code for Existing Elevators and Escalators*.

AISC Book #S326, 1978, *Specification for Design, Fabrication, and Erection of Structural Steel for Buildings*.

ANSI/AWS D1.1 (latest edition), *Structural Welding Code – Steel*.

ANSI/AWS D1.3 (latest edition), *Structural Welding Code - Sheet Steel*.

ANSI/ASME B29.1, 1975, *Precision Power Transmission Roller Chains, Attachments, and Sprockets*.

ASME QE1-1 (latest edition), *Standard for the Qualification of Elevator Inspectors*.

ASME/ANSI Y1.1 (latest edition), *Abbreviations for Use on Drawings and in Text*.

ANSI/NFPA 70-1993, *National Electrical Code®*.

ANSI/NFPA 101 (latest edition), *Life Safety Code®*.

ANSI/RMA IP-20, 1977, *Specifications for Drives Using Classical Multiple V-Belts (A, B, C, D, E Cross Sections)*.

ANSI/UL94 (latest edition), *Test of Flammability of Plastic Materials for Parts in Devices and Appliances*.

ANSI Z97.1-1984, *Performance Specifications and Methods of Test for Safety Glazing Material Used in Buildings*.

C.3 References in the Japanese Code

JEA C8001, *Interior wiring code*.

JEAS-1003B, *Escalator specifications*.

JEAS-1004B, *Structural calculation for escalator*.

JEAS-A1021A, *Report of escalator conditions form after work completion*.

JIS A4302, *Inspection Standard of Elevator, Escalator and Dumbwaiter*.

JIS C2410, *P.V.C. tubing for electrical insulation*.

JIS C2415, *Extruded tubes for electrical insulation*.

JIS C 3301, *Rubber insulated flexible cords*.

JIS C 3306, *Polyvinyl chloride insulated flexible cords*.

JIS C 3307, *V polyvinyl chloride insulated wires*.

JIS C 3316, *Polyvinyl chloride insulated wires for electrical apparatus*.

JIS C 3317, *600V grade heat-resistant polyvinyl chloride insulated wires*.

JIS C 3327, *600V rubber insulated flexible cables*.

JIS C 3342, *600V polyvinyl chloride insulated and sheathed cables*.

JIS C 3401, *Control cables.*

JIS C 3408, *Travelling cables for elevators.*

JIS C 3652, *Installation methods of power flat conductor cables.*

JIS C8325, *AC electromagnetic switches.*

JIS K6324, *Flame resistant conveyor belts – Classification and test method.*

Annex D
(informative)

**Addresses of standardization bodies occupied with the
compared codes**

EUROPE

European Committee for Standardization (CEN)

Avenue Marnix 17

B-1000 Brussels

UNITED STATES OF AMERICA

ASME International

Three Park Avenue

New York, NY 10016-5990

CANADA

Canadian Standards Association (CSA)

5060 Spectrum Way

Mississauga

ON L4W 5N6

JAPAN

Japanese Industrial Standards Committee

c/o Technical Regulation, Standards and Conformity Assessment Policy Unit,

Ministry of Economy, Trade and Industry

1-3-1, Kasumigaseki, Chiyoda-ku

Tokyo 100-8901

