

First edition
2005-04-15

Wheelchairs —

Part 1:
**Guidelines for the application of the
ISO 7176 series on wheelchairs**

Fauteuils roulants —

*Partie 1: Lignes directrices pour l'application de la série ISO 7176 aux
fauteuils roulants*



Reference number
ISO/TR 13570-1:2005(E)

PDF disclaimer

This PDF file may contain embedded typefaces. In accordance with Adobe's licensing policy, this file may be printed or viewed but shall not be edited unless the typefaces which are embedded are licensed to and installed on the computer performing the editing. In downloading this file, parties accept therein the responsibility of not infringing Adobe's licensing policy. The ISO Central Secretariat accepts no liability in this area.

Adobe is a trademark of Adobe Systems Incorporated.

Details of the software products used to create this PDF file can be found in the General Info relative to the file; the PDF-creation parameters were optimized for printing. Every care has been taken to ensure that the file is suitable for use by ISO member bodies. In the unlikely event that a problem relating to it is found, please inform the Central Secretariat at the address given below.

© ISO 2005

All rights reserved. Unless otherwise specified, no part of this publication may be reproduced or utilized in any form or by any means, electronic or mechanical, including photocopying and microfilm, without permission in writing from either ISO at the address below or ISO's member body in the country of the requester.

ISO copyright office
Case postale 56 • CH-1211 Geneva 20
Tel. + 41 22 749 01 11
Fax + 41 22 749 09 47
E-mail copyright@iso.org
Web www.iso.org

Published in Switzerland

Contents

Page

Foreword	iv
1 Scope	1
2 How to use this Technical Report	2
3 Standardized testing and information disclosure	2
3.1 General	2
3.2 Background on tests and standards	2
3.3 Standards increase your buying power	2
3.4 More about International Standards	3
3.5 How chairs are tested	5
3.6 How information is disclosed	5
4 General considerations	6
4.1 Manual versus powered wheelchairs	6
4.2 Rigid versus folding manual wheelchairs	8
4.3 Direct-drive versus belt-drive powered wheelchairs	8
4.4 Cost	9
5 Incorporating personal body characteristics	10
5.1 Body size	10
5.2 Seating	11
5.3 Joint flexibility	19
5.4 Propulsion skill	21
6 Manual wheelchairs	23
6.1 Performance	23
6.2 Safety	31
6.3 Dimensions	36
7 Powered wheelchairs	39
7.1 Performance	39
7.2 Safety	49
7.3 Dimensions	60
Annex A (informative) Additional information not required for disclosure in the manufacturer's technical product literature	65
Bibliography	68

Foreword

ISO (the International Organization for Standardization) is a worldwide federation of national standards bodies (ISO member bodies). The work of preparing International Standards is normally carried out through ISO technical committees. Each member body interested in a subject for which a technical committee has been established has the right to be represented on that committee. International organizations, governmental and non-governmental, in liaison with ISO, also take part in the work. ISO collaborates closely with the International Electrotechnical Commission (IEC) on all matters of electrotechnical standardization.

International Standards are drafted in accordance with the rules given in the ISO/IEC Directives, Part 2.

The main task of technical committees is to prepare International Standards. Draft International Standards adopted by the technical committees are circulated to the member bodies for voting. Publication as an International Standard requires approval by at least 75 % of the member bodies casting a vote.

In exceptional circumstances, when a technical committee has collected data of a different kind from that which is normally published as an International Standard ("state of the art", for example), it may decide by a simple majority vote of its participating members to publish a Technical Report. A Technical Report is entirely informative in nature and does not have to be reviewed until the data it provides are considered to be no longer valid or useful.

Attention is drawn to the possibility that some of the elements of this document may be the subject of patent rights. ISO shall not be held responsible for identifying any or all such patent rights.

ISO/TR 13570-1 was prepared by Technical Committee ISO/TC 173, *Assistive products for persons with disability*, Subcommittee SC 1, *Wheelchairs*.

This first edition cancels and replaces the first edition of ISO/TR 13570:2001, of which it constitutes a minor revision. This part of ISO/TR 13570 is based on the book, *A Guide to Wheelchair Selection: How to Use the ANSI/RESNA Wheelchair Standards to Buy a Wheelchair*, written by Peter Axelson, Jean Minkel and Denise Chesney, published in 1994 by the Paralyzed Veterans of America, Washington, DC, USA.

ISO/TR 13570 consists of the following parts, under the general title *Wheelchairs*:

— *Part 1: Guidelines for the application of the ISO 7176 series on wheelchairs*

The following part is under preparation:

— *Part 2: Typical values and recommended limits or dimensions, mass and manoeuvring space as determined in ISO 7176-5*

Wheelchairs —

Part 1: Guidelines for the application of the ISO 7176 series on wheelchairs

1 Scope

The purpose of this part of ISO/TR 13570 is to explain how you can use the International Standards on wheelchairs to select your next wheelchair. The actual standards are very technical and, at first glance, you may not understand how this information will help you select a wheelchair or scooter. This part of ISO/TR 13570 is meant to help you understand the purpose for and content of International Standards on wheelchairs.

This part of ISO/TR 13570 is divided into six clauses.

- a) How to use this Technical Report.
- b) Standardized testing and information disclosure: Provides background information on standardized testing of wheelchairs. Discusses how chairs are tested and how information is disclosed.
- c) General considerations: Discusses general considerations related to choosing a powered or manual wheelchair.
- d) Incorporating personal body characteristics: Relates your physical characteristics to the fit of a chair, either manual or powered.
- e) Manual wheelchairs: Discusses manual wheelchair test procedures.
- f) Powered wheelchairs: Discusses powered wheelchair test procedures; focuses on three- and four-wheeled scooters as well as full-sized powered wheelchairs.

In the manual and powered wheelchair sections, the test procedures are grouped into three categories:

- performance,
- safety, and
- dimensions.

For each test procedure, this part of ISO/TR 13570 includes

- reasons why you might need this information,
- a brief description of the standardized test procedure,
- how the results of the test will be disclosed in the manufacturer's technical product literature, and
- how to interpret the results of the test for your own situation.

2 How to use this Technical Report

If you are an experienced rider, you may know which elements of performance, safety and dimension are important to you. If not, or if you are a novice, we highly recommend that you involve other knowledgeable people in selecting your wheelchair. Many rehabilitation specialists have the expertise and training in using these standards and can help you select an appropriate wheelchair.

An excellent approach to the wheelchair selection process is to set priorities based on your mobility and seating needs. Setting priorities will help you identify the features that are most important to you and those on which you are willing to compromise. For example, if you live in a small apartment and need to fit your wheelchair into the boot (trunk) of your car, you will probably want to look specifically at the overall dimensions, foldability, and weight of the wheelchair. On the other hand, if you use a van and have an accessible apartment or home, you may not need a folding wheelchair. This part of ISO/TR 13570 will help you understand the test results that pertain to the factors most important to you. Armed with this information, you will be able to accurately compare products and make an informed purchasing decision.

3 Standardized testing and information disclosure

3.1 General

Purchasing a wheelchair can be a harrowing experience and finding the right chair among so many choices might seem impossible. Comparing wheelchair characteristics and performance has been difficult in the past because manufacturers used different standards and procedures to measure and test their chairs. For example, one manufacturer measured seat width from the outside of the seat rails, another measured from inside the rails, and a third measured the distance between the armrest panels. Thus, if you requested a chair with a seat width of 18 inches, the actual distance from the outside of the seat rails could be anywhere from 17 inches to 19 inches. This inconsistency, as well as a general concern for user safety, led to the development of standardized wheelchair measurements and test procedures. The results of these procedures will provide you with the information you need for true comparison shopping.

3.2 Background on tests and standards

The ISO Technical Committee on wheelchairs has been working to provide consumers with objective information about the characteristics and performance of wheelchairs. The committee includes rehabilitation engineers, wheelchair manufacturers, agency representatives, wheelchair users, and wheelchair prescribers.

The standards developed by the committee consist of a number of test procedures that apply to all wheelchairs and some that apply only to powered wheelchairs, including scooters. The test procedures are detailed instructions on how to perform the tests or measurements on wheelchairs. Some of the test procedures suggest minimum performance criteria for durability and safety, while others disclose the results of the tests for comparison purposes. The information obtained from the tests is designed to help you make better-educated selections. See Figure 1. The standardized test procedures also allow you to compare the test results of wheelchairs from different manufacturers. Since many of the test procedures set minimum performance levels, they also help manufacturers produce better products.

3.3 Standards increase your buying power

The standards are voluntary: manufacturers are not required by law to use the test procedures. However, if consumers start using the results as a basis for wheelchair selection, the manufacturers who do not use the standards may lose sales. The US Department of Veterans Affairs (VA), the single largest purchaser of wheelchairs in the United States, is adopting the standards for future wheelchair purchasing. Marketplace pressure will most likely encourage overall compliance with the standards.

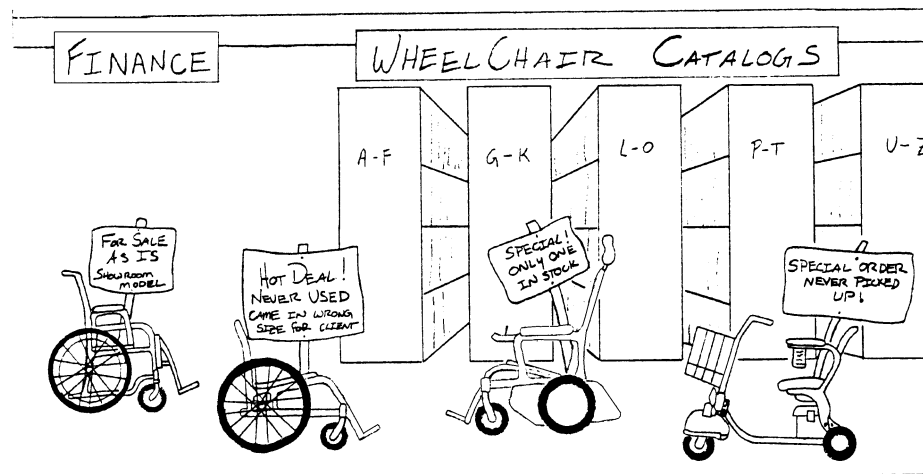

Figure 1 — Finding the right chair among so many choices might seem impossible

3.4 More about International Standards

To gain the maximum benefit from the standardized testing, both consumers and professionals must understand how to use the information.

The following is a list of the test standards, listed by their ISO number designation, that apply to all wheelchairs, with a brief description of the test procedure.

- ISO 6440:1985,** *Wheelchairs — Nomenclature, terms and definitions.* This International Standard establishes the terms and definitions used in the test procedures.
- ISO 7193:1985,** *Wheelchairs — Maximum overall dimensions.* This International Standard establishes suggested maximum dimensions of a chair for other organizations to use as guidelines for architectural accessibility.
- ISO 7176-1:1999,** *Wheelchairs — Part 1: Determination of static stability.* This test determines how stable the wheelchair is when it is resting on a sloped surface.
- ISO 7176-3:2003,** *Wheelchairs — Part 3: Determination of efficiency of brakes.* This test determines how well the wheel locks (parking brakes) prevent the wheelchair from rolling on a sloped surface. This test also determines the minimum stopping distance of a powered wheelchair at its maximum speed.
- ISO 7176-5:1986,** *Wheelchairs — Part 5: Determination of overall dimensions, mass and turning space.* This part addresses the overall length, width, height, folded width, mass and turnaround space of the chair.
- ISO 7176-7:1998,** *Wheelchairs — Part 7: Measurement of seating and wheel dimensions.* This part addresses the dimensional information needed to fit a chair to a rider. Standard methods of measurement eliminate the problems that result from variations in measurement methods.
- ISO 7176-8:1998,** *Wheelchairs — Part 8: Requirements and test methods for static, impact and fatigue strengths.* This part addresses the strength and durability of a wheelchair.
- ISO 7176-11:1992,** *Wheelchairs — Part 11: Test dummies.* This part addresses the dimensional and mass (weight) specifications of the dummies to be used when conducting the tests.

ISO/TR 13570-1:2005(E)

- ISO 7176-13:1989**, *Wheelchairs — Part 13: Determination of coefficient of friction of test surfaces*. This test describes the roughness or slipperiness of the surface to be used for testing.
- ISO 7176-15:1996**, *Wheelchairs — Part 15: Requirements for information disclosure, documentation and labelling*. This part tells what information manufacturers are required to disclose and how it should be disclosed in their product literature, if they choose to comply with the standards.
- ISO 7176-16:1997**, *Wheelchairs — Part 16: Resistance to ignition of upholstered parts — Requirements and test methods*. This test addresses the extent to which upholstery will burn and how fire retardant the upholstery is.
- ISO 7176-19:2001**, *Wheelchairs — Part 19: Wheeled mobility devices for use in motor vehicles*. This part sets out the design and performance requirements, and associated test methods, for wheelchairs that are intended for use as a seat in a motor vehicle.
- ISO 7176-22:2000**, *Wheelchairs — Part 22: Set-up procedures*. This part specifies the procedures for configuring and adjusting a wheelchair prior to testing.
- ISO 7176-23:2002**, *Wheelchairs — Part 23: Requirements and test methods for attendant-operated stair-climbing devices*. This part determines the performance of stair-climbing devices that are operated by an attendant.
- ISO 7176-24:2004**, *Wheelchairs — Part 24: Requirements and test methods for user-operated stair-climbing devices*. This part determines the performance of stair-climbing devices that are operated by the occupant.

The following is a list of test procedures that apply to powered wheelchairs only:

- ISO 7176-2:2001**, *Wheelchairs — Part 2: Determination of dynamic stability of electric wheelchairs*. This part addresses how stable a powered wheelchair is in the rearward, forward and lateral directions when it is driven.
- ISO 7176-4:1997**, *Wheelchairs — Part 4: Energy consumption of electric wheelchairs and scooters for determination of theoretical distance range*. This test addresses the energy consumption of a powered wheelchair on a standardized track.
- ISO 7176-6:2001**, *Wheelchairs — Part 6: Determination of maximum speed, acceleration and deceleration of electric wheelchairs*. This part addresses the maximum speed in forward and reverse. It also determines the minimum time from stationary to maximum speed (acceleration) and from maximum speed to a complete stop (retardation).
- ISO 7176-9:2001**, *Wheelchairs — Part 9: Climatic tests for electric wheelchairs*. This part addresses the effects of rain and temperature changes on the functioning of a powered wheelchair.
- ISO 7176-10:1988**, *Wheelchairs — Part 10: Determination of obstacle-climbing ability of electric wheelchairs*. This test determines how high an obstacle a powered wheelchair can climb over.
- ISO 7176-14:1997**, *Wheelchairs — Part 14: Power and control systems for electric wheelchairs — Requirements and test methods*. This test addresses safety, how well the fail-safe braking mechanism works, the force required to actuate the controls, and other issues related specifically to powered wheelchairs.
- ISO 7176-21:2003**, *Wheelchairs — Part 21: Requirements and test methods for electromagnetic compatibility of electrically powered wheelchairs and motorized scooters*. This part addresses the electromagnetic emissions and electromagnetic immunity of powered wheelchairs, including scooters.

3.5 How chairs are tested

The International Standards on wheelchairs are specific instructions on how to perform the test procedures. Some of the test procedures have minimum performance requirements, including flammability and climatic tests, static and impact strength tests, and power and control systems tests for powered wheelchairs. The results of the minimum performance tests are either pass or fail. These tests ensure minimum performance and safety of the product. See Figure 2.

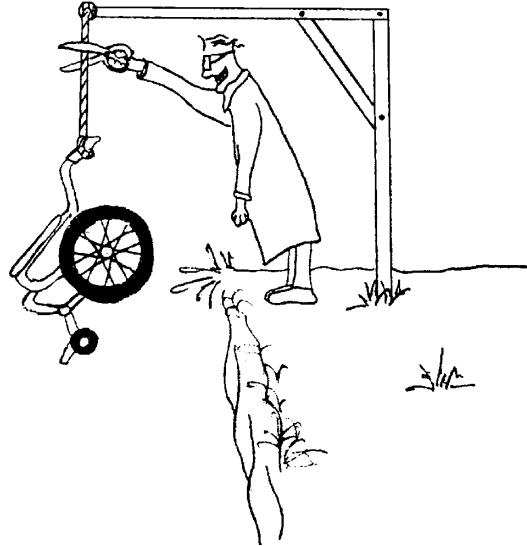

Figure 2 — Testing of wheelchairs has become more sophisticated over the years

Most of the test procedures are performance tests that produce quantified information about a chair. The results give information for comparison purposes only; there is no pass or fail determination. These comparisons are meaningful because, for the first time, each manufacturer uses the same tests. Until now, different manufacturers described their wheelchairs using different terms. By comparing test results of different chairs, you can begin comparative wheelchair shopping.

Most of the tests are conducted with a test dummy in the chair to represent the weight of a person. The results for chairs tested in this “loaded” condition more closely approximate the fit and performance of a chair when it is actually occupied. Your own body size, body proportions riding style may affect the actual fit and performance of a chair.

For wheelchair components that are adjustable, the manufacturer adjusts the wheelchair configuration and controls to obtain the extreme range of outcomes for a specific test procedure. For example, rear axle position and other adjustable features affect the stability of a chair. In this case, the manufacturer tests the wheelchair with its rear wheels and other adjustable features in both the least and most stable configurations. These results give a range of tipping angles that reflects the least stable and most stable configurations that can be obtained by adjusting the rear wheels and other features of the wheelchair. On a powered wheelchair with an adjustable controller, the manufacturer will disclose a range of stopping distances to reflect the adjustability of speed and retardation (deceleration).

3.6 How information is disclosed

Manufacturers that wish to comply with the International Standards on wheelchairs must comply with ISO 7176-15, *Wheelchairs — Part 15: Requirements for information disclosure, documentation and labelling*, which specifies which test results must be contained in the pre-sale technical product literature. A list of the additional tests that the manufacturer is required to perform is contained in Annex A. The manufacturer is not required to disclose the results of these additional tests in the technical product literature, but the consumer can request this information. See Figure 3.

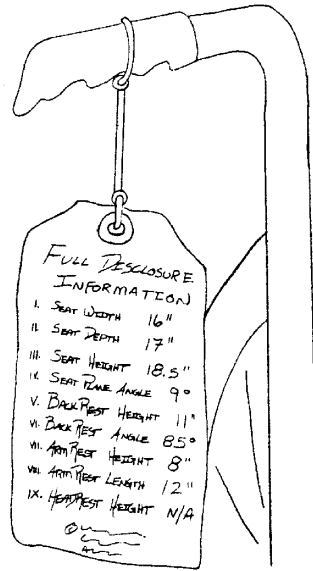

Figure 3 — To be in compliance with the ISO test procedures, manufacturers are required to disclose certain information about the chair in their pre-sale technical product literature

The test results of particular procedures are disclosed as performance values, which at first may have little or no meaning to you. For example, a manufacturer may disclose the rear-tipping angle of a wheelchair, but there is no minimum performance value available for comparison at this time. However, you can look up the tip angle or the range of tip angles for a specific wheelchair with which you have experience, then look at the tip angles of other wheelchairs and figure out how these chairs will perform compared with the chair you know. For example, suppose your current wheelchair has a rear tip angle of 4°. You can determine if the wheelchair you are considering is more or less tippy than your current chair by finding out if its rear tip angle is greater or less than 4°. As you gain experience using one wheelchair, the information about other wheelchairs will become more meaningful to you.

NOTE The performance ratings are usually based on testing only one wheelchair. The results disclosed represent the maximum performance of a new wheelchair tested without failure. The performance you get from your wheelchair will vary depending on your body size and proportion, physical strength, abilities, skills and riding habits and on environmental conditions.

4 General considerations

4.1 Manual versus powered wheelchairs

4.1.1 General

Rehabilitation programmes used to emphasize that if it was possible for you to push a manual wheelchair, you should do so. The saying was “Use it or lose it.” However, many people with marginal ability to use a manual wheelchair find that they deplete all their energy resources just trying to get where they want to go. Once they get there, they have no energy left to do what they want to do. Worse yet, people with 20 or 30 years of experience pushing a manual wheelchair realise that their shoulders are worn out as a result of the years of “using it” and not “losing it.” Should healthy manual wheelchair riders spend some time in a powered wheelchair? To answer this question, do some self-examination. Ask yourself which type of mobility meets your needs. See Figure 4.

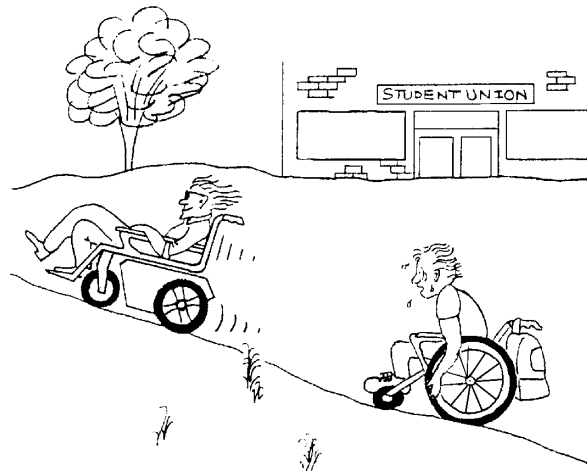

Figure 4 — In some environments, a manual wheelchair may not leave you with the energy that you will need when you get to your destination

4.1.2 Some reasons to select manual mobility

You have sufficient upper body strength and overall endurance to propel your wheelchair all day.

Reducing the weight or increasing the manoeuvrability of the wheelchair would enhance your independence.

Some of your daily activities are easier to perform in a manual chair.

A manual wheelchair is smaller, lighter and less expensive to maintain and repair.

You are not experiencing chronic pain in your arms or shoulders.

4.1.3 Some reasons to select powered mobility (including scooters)

You have insufficient endurance or functional ability to propel a manual wheelchair independently.

You need to conserve energy during long-distance wheeling to work or school.

Powered mobility would enable you to be more independent in your daily living, work and recreational activities.

You have access to personal or public transportation that accommodates a full-sized powered chair or scooter for longer distance travel.

Many powered wheelchair riders have a manual wheelchair to use when a powered wheelchair is inconvenient. When travelling, a powered wheelchair user may use a manual wheelchair and have a person help with mobility. Other users may rely on a manual wheelchair at home and at work and use a powered wheelchair for travelling to and from work. There is something to be said for the use of a powered wheelchair to prevent overuse of the shoulder muscles, although this option is not often discussed. Financial considerations are important as well, since powered wheelchairs are expensive. Whether the primary wheelchair is powered or manual, a backup manual wheelchair should be available in the event of breakdown of the main wheelchair.

4.2 Rigid versus folding manual wheelchairs

If you plan to use a manual wheelchair, the first decision you have to make is whether it should be rigid or folding. Nonfolding fixed-frame chairs are more rigid, whereas folding chairs tend to have a little more flex in the frame. This flex can be an advantage when you are travelling over slightly uneven surfaces, because all the wheels of the chair tend to stay on the ground. When you use a rigid wheelchair on an uneven surface, one wheel often lifts off the ground. However, on a hard floor surface, a rigid-frame chair gives a more responsive feeling, since all the energy you expend goes into propulsion and none goes into flexing the frame of the chair. Many people prefer the aesthetics of a rigid frame (see Figure 5), although both types are available in lightweight models and in a variety of colours. Some of the advantages and disadvantages are listed in Table 1.

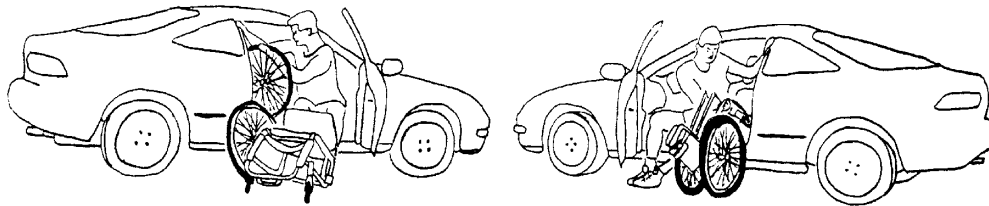

Figure 5 — Getting a folding wheelchair into and out of a car can be quicker than a rigid-frame chair. However, many riders prefer the performance of a rigid-frame chair on hard surface floors

Table 1 — Rigid versus folding wheelchairs

	Advantages	Disadvantages
Rigid frame	<ul style="list-style-type: none"> • Frame design requires fewer components and thus has more strength for a given mass • Usually a lighter chair than a similarly equipped folding chair • Fewer removable parts • Required to meet National Wheelchair Basketball Association specifications • Seat-to-back angle is often adjustable 	<ul style="list-style-type: none"> • Requires removal of quick-release rear wheels for loading into car • May feel bumpier on uneven surfaces • Does not fold into as small a package for stowing in car or aeroplane
Folding frame	<ul style="list-style-type: none"> • Folds into compact package for stowing in car or aeroplane • Flexes to enable all four wheels to stay on the ground when riding on uneven surfaces • Can be folded and stowed without removing parts 	<ul style="list-style-type: none"> • More moving, adjustable, and removable components • May not meet rider's sports or leisure activity needs • Seat-to-back angle usually not adjustable • Lateral stability can decrease as the chair flexes or starts to fold

4.3 Direct-drive versus belt-drive powered wheelchairs

When the motors are mounted directly to the drive wheels with only gears in between, the system is called a direct-drive system. When belts connect the motors to the drive wheels, the system is called a belt-drive system. Most wheelchairs are only available one way or the other. Keep in mind when comparing two scooters that one may have a direct-drive system while the other may have a belt-drive system. Full-sized powered chairs are also manufactured with either a direct-drive or a belt-drive system.

Like the rigid-frame manual wheelchair, the direct-drive system has no flex or slack. The drive wheels respond directly to the actions of the motors. The belt, on the other hand, introduces a slight delay between the action of the motor and the wheel. Depending on your trunk balance, you may find the delay in a belt-driven chair provides a more comfortable ride. Unfortunately, belts can slip if they are not properly adjusted or if they are wet, and the rear wheels will not always respond when you want them to. You must look at the advantages of direct drive versus belt drive and make the best choice for your needs and your environment. See Figure 6.

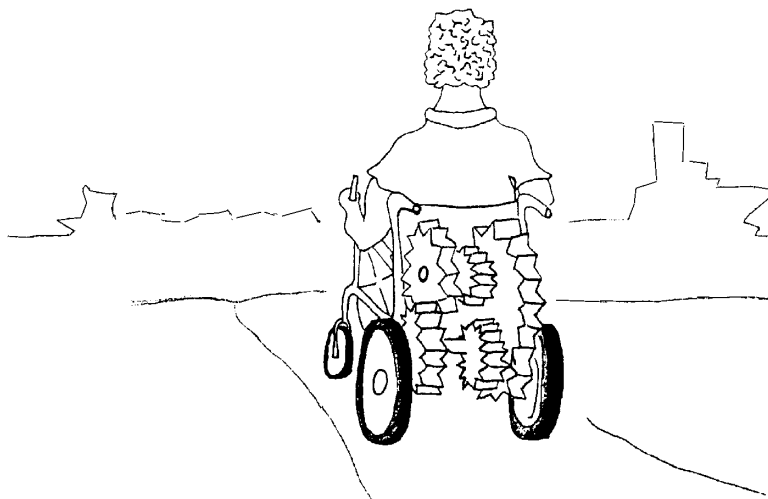

Figure 6 — Many users choose lower maintenance direct-drive chairs despite some drawbacks

Some of the advantages and disadvantages of the two drive systems are listed in Table 2.

Table 2 — Direct-drive versus belt-drive powered wheelchairs

	Advantages	Disadvantages
Direct drive	<ul style="list-style-type: none"> • Requires little maintenance • No exposed parts to cause wear from dirt 	<ul style="list-style-type: none"> • Can be noisy during operation • Gears wear if not properly lubricated
Belt drive	<ul style="list-style-type: none"> • Belts can be easily replaced • Generally quiet during operation • Can provide a smooth ride 	<ul style="list-style-type: none"> • Chair will drive in a circle if a belt breaks • Belts can slip when wet, reducing control • Generally requires more maintenance • May require adjustments if there is a change in temperature • Belts can be noisy during start-up

4.4 Cost

Seating and mobility professionals can provide a thorough clinical evaluation of your needs, environment, size and functional strengths and limitations to help you choose the appropriate wheelchair. In addition, the rehabilitation facility may have a variety of wheelchairs on hand to demonstrate the “latest and greatest” in design and components. A proper clinical evaluation and knowledge of available components may prevent costly mistakes. Many wheelchair users have received chairs that did not fit or did not meet their functional needs as a result of an uninformed decision. In most cases, the rehabilitation centre will assemble and adjust the chair to fit you, and training is often available through the centre or the wheelchair supplier to help you learn the performance characteristics of the chair.

If you feel you can bypass seating and mobility professionals because you have enough personal experience, you may be able to save money by purchasing the wheelchair directly from a mail-order house or with cash through a local supplier. As with any mail-order purchase, you will forgo local support, including warranty repairs, assembly, set-up and adjustment to fit your body, abilities and skills. Such a purchase also will not include training, which you might need if the new wheelchair has very different performance characteristics from your previous one.

5 Incorporating personal body characteristics

5.1 Body size

Just knowing your height and weight is not enough to determine the appropriate dimensions of your wheelchair. In order to achieve the best fit, you also need to know the dimensions of your body in a seated position. When measuring your body size, it is helpful to sit in a wheelchair that is as close to the correct size as possible. If you are ordering a wheelchair with sling upholstery, you should be measured while sitting in a chair with sling upholstery. If you are ordering a wheelchair with rigid seat and back surfaces, you should be measured sitting in a wheelchair with a rigid seat and back, or at least on a surface with similar characteristics. If you will be using a seat cushion, sit on the same type and size of cushion you will use in the new chair. Be sure to consider the seat cushion as part of your body while making the measurements. If you sit on a cushion that is lower or higher than the one you will be using in your new chair, the measurements will be incorrect.

The measurements you will use are

- seat width,
- seat depth,
- seat surface height,
- backrest height, and
- footrest-to-seat distance.

If you use armrests and/or a headrest you will need to know

- armrest height,
- front of armrest to backrest distance,
- armrest length,
- front location of armrest structure,
- distance between armrests, and
- headrest height.

Until now, figuring the dimensions of a wheelchair to fit an individual used to be a nightmare, because there was no standard measurement method. Each manufacturer had his own way of making measurements. Also, all manufacturers measured their chairs empty, although the size of the chair may change when a person sits in it. The fabric seat and back upholstery may give, pulling the two sides of the chair together, thus changing its size.

The ISO test procedures require that the wheelchair be measured “loaded” with a weighted test dummy. The test dummy sizes represent the size and mass of the intended rider: large adult [100 kg (220 lbs)], adult [75 kg (165 lbs)], small adult [50 kg (110 lbs)] and child [25 kg (55 lbs)]. Specifying a chair to fit you will be

much more accurate when working with dimensions that represent the size of an occupied chair. Although figuring out the dimensions of a wheelchair can still be pretty challenging, you will find that the test procedures provide more accurate information and that measurements from different manufacturers can be compared.

5.2 Seating

5.2.1 Seat width

Generally, to enhance accessibility, the width of a chair should be as narrow as possible without causing pressure on the rider's hips. An increase in seat width usually results in an increase in the overall width of the chair. You might select a wider wheelchair if you wanted a chair that was more stable sideways.

Another consideration is the type of clothing that you will be wearing. If you generally wear a suit or jacket, you may want a little extra room for tucking in your clothing on the sides. See Figure 7.

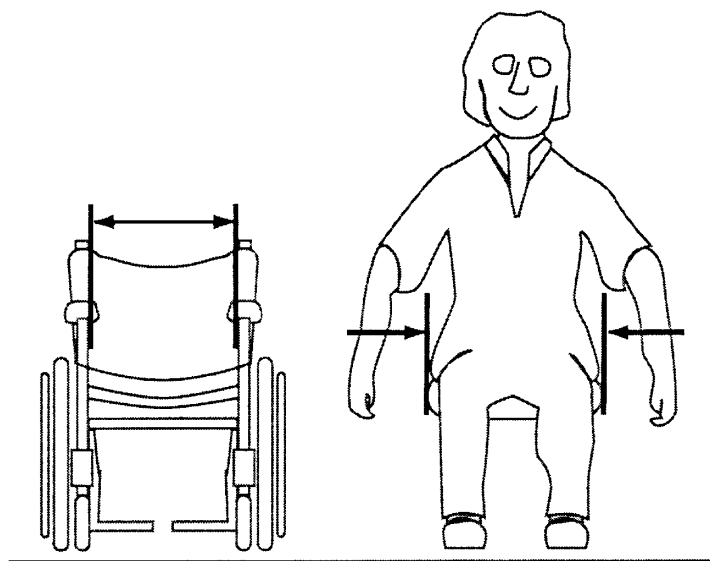

Figure 7 — Seat width

5.2.2 Seat depth

The seat should be long enough to provide adequate leg support, which creates better weight distribution. If your legs can support weight, a longer seat depth will spread your weight out more over your thighs. This means that the amount of weight on your bony prominences will be decreased, thus decreasing the risk of pressure sores. If the seat is too long, however, the front edge will catch the back of your knees. The effective seat depth of a chair with a fabric backrest will measure longer than one with a rigid back support surface.

If you will be adding a rigid back support to a wheelchair with sling upholstery, the seat depth of your chair may change. It is a good idea to install the back support on a wheelchair similar to the one you will be ordering to determine how much the seat depth will change. See Figure 8.

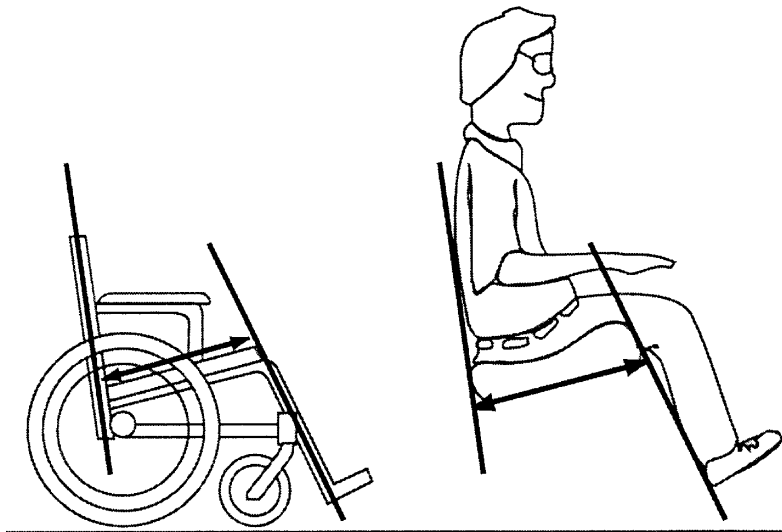

Figure 8 — Seat depth

The seat depth is increased even more when a chair is equipped with legrests that have calf supports. Calf supports hold the legs forward of the front edge of the seat. If this is not taken into consideration when ordering the wheelchair, this may prevent you from positioning your buttocks against the backrest and would then cause you to sit in a slumped sitting posture. See Figure 9.

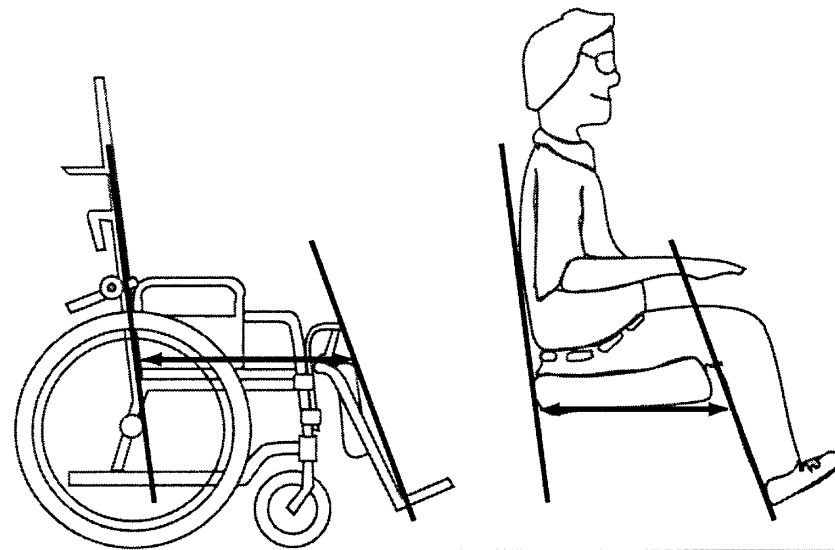

Figure 9 — Calf supports

5.2.3 Seat surface height

The wheelchair seat must be high enough to accommodate the length of your legs and yet low enough so that your legs will fit under tables. Some users prefer to sit up higher so they are more eye-to-eye with people sitting or standing next to them.

If the chair has a fabric seat, the seat surface height will measure a bit lower than one with a rigid seating surface. The distance disclosed by the manufacturer will not include the height of a seat cushion. If you will be

using a seat cushion, determine your appropriate wheelchair seat height while sitting on that seat cushion. Sit in a similar wheelchair and then measure to the bottom of your seat cushion. See Figure 10.

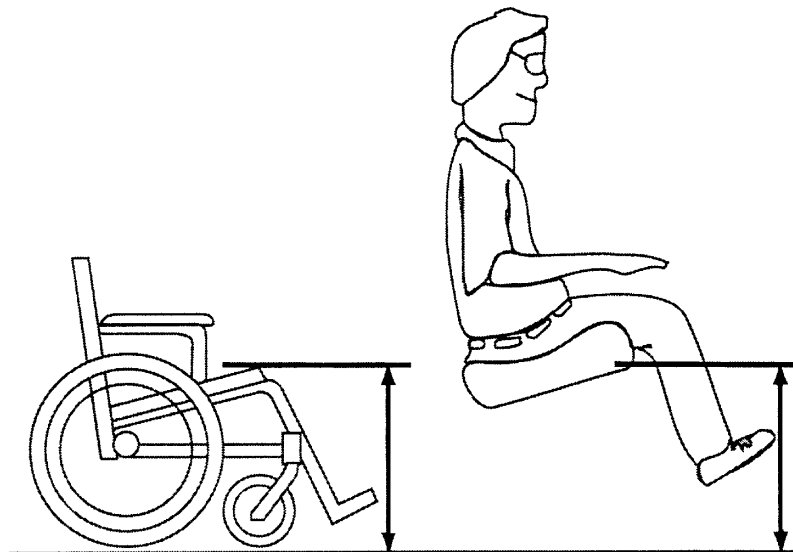

Figure 10 — Seat surface height at front edge

If the seat height is too low and you use footrests, the footrests may not have enough ground clearance and may scrape the ground at dropped kerbs. A seat that is too high can make transferring into and out of your chair more difficult. Manual wheelchair users should keep in mind that changing the seat height will also change your body's relationship to the drive wheels and may affect your ability to push your chair. A higher seat will make it harder to reach the pushrims, while a lower seat will allow you to reach more of the pushrims.

The seat height is very important for people with hemiplegia or others who propel their chairs using their feet. If you propel the chair with your feet, you might need a lower seat.

5.2.4 Backrest height

The height of the backrest depends on the rider. Some wheelchair riders want a low backrest for enhanced upper body movement or because they like the way it looks. Higher backrests help support riders who have less upper body balance. Regardless of the backrest height, be sure that the back posts or push handles do not interfere with your arm movements while you are wheeling.

The backrest height disclosed by the manufacturer will not include the thickness of the seat cushion. The backrest height is measured from the seat surface of the wheelchair. When determining your backrest height, make sure you are seated on the seat cushion that you intend to use. Measure from the surface on which the seat cushion is resting. See Figure 11. Since this measurement is made from the wheelchair upholstery surface, the backrest height measurement will be slightly higher for a wheelchair with sling upholstery than for a chair with a rigid seat.

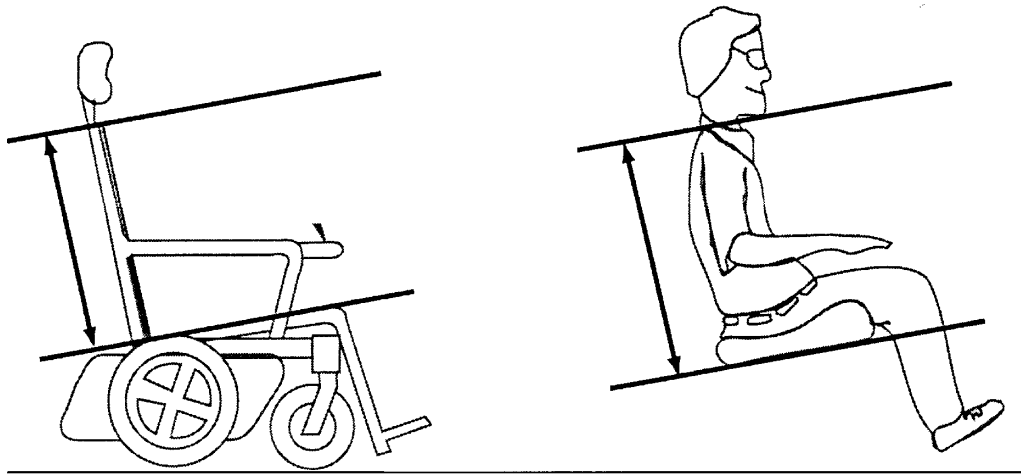

Figure 11 — Backrest height

5.2.5 Footrest-to-seat distance

The manufacturer will measure and report the footrest-to-seat distance without a seat cushion on a loaded wheelchair. To determine if the wheelchair will accommodate your leg length, sit on your cushion in a wheelchair with a similar seating surface. Measure from the bottom of the shoes that you normally wear to the front edge of the seating surface just beneath your cushion. See Figure 12.

If the footrest length is adjustable, the manufacturer will indicate the range available for a particular chair and footrest. If the range does not meet your needs, remember that footrests are usually available in a variety of styles; a different footrest may provide the range of adjustment necessary to accommodate your leg length. Sometimes changing the footrests is not enough. If you have very long or very short legs, you may need to look for a different frame style. Tall or short frames, for proportionately taller or shorter people, are available in some models. To accommodate long legs, you might also need a higher seat or a greater seat-to-leg angle.

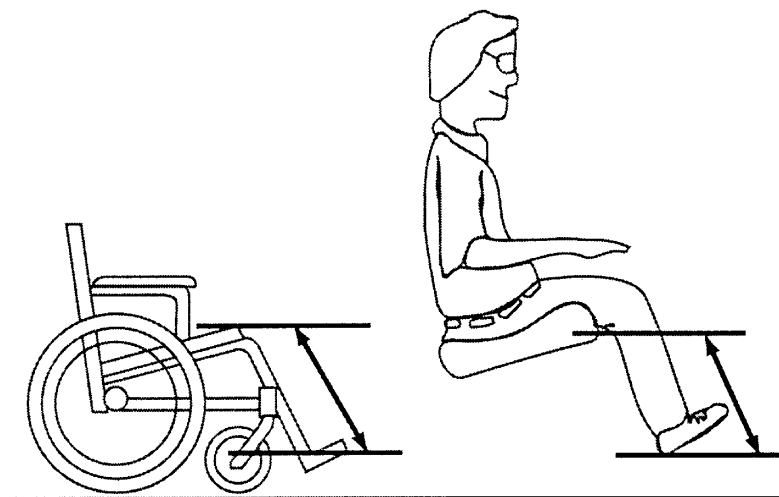

Figure 12 — Footrest-to-seat distance

Once the footrest is adjusted for you, you should have at least 2 inches of clearance under your foot pedals to save you from hitting the bottom of dropped kerbs with your foot pedals. Footrest clearance and leg length must be considered before selecting a seat height.

Footrests are available in a wide variety of styles and variations. The type of footrest that is appropriate for you will depend on your size, needs and preferences. The features given in Table 3 may be available from the manufacturer.

Table 3 — Features of footrests

Footrests	Description
Adjustable length	<ul style="list-style-type: none"> • Usually a standard feature • Accommodates a range of leg lengths
Swing away, detachable	<ul style="list-style-type: none"> • Necessary for some riders to be able to transfer or to put the chair in the car
Flip-up	<ul style="list-style-type: none"> • Required for folding wheelchairs • Facilitates some types of transfers
Folding footplate	<ul style="list-style-type: none"> • Non-flip-up • Folds for storage
Impact guard	<ul style="list-style-type: none"> • Hard plastic, wheel-shaped bumper on the outer front edge of the footrest • Useful for pushing open doors • Prevents the footrest from catching on obstacles, such as dropped kerbs and doors, and from digging into floor surfaces • Required for indoor basketball wheelchairs
Elevating	<ul style="list-style-type: none"> • Usually an optional feature • Usually enables elevation of one leg at a time
90°-90° platforms	<ul style="list-style-type: none"> • Accommodates shorter leg lengths • Usually used for children
Rigid single unit	<ul style="list-style-type: none"> • Usually found on rigid-frame wheelchairs • Generally much stronger
Calf support strap	<ul style="list-style-type: none"> • Prevents the feet from falling back underneath the chair
Calf support	<ul style="list-style-type: none"> • Usually provided with elevating leg rests • Prevents the legs from slipping back underneath the wheelchair

5.2.6 Armrest and headrest

5.2.6.1 General

If you use armrests, several measurements in the test procedures may be of interest to you: armrest height, front of armrest to backrest distance, and the armrest length.

5.2.6.2 Armrest height

The armrest height is an important dimension to consider. The manufacturer reports the distance from the top of the armrest to the top of the loaded seating surface of the wheelchair. The measurement for a wheelchair with sling upholstery will be different than for one with a rigid seating surface. To determine the armrest height you need, sit on your seat cushion in a chair with a seating surface like the one you will be purchasing. Hang your arm down at your side, bend your elbow 90°, and measure the distance from the bottom of your elbow down to the seating surface of the wheelchair beneath the cushion. See Figure 13.

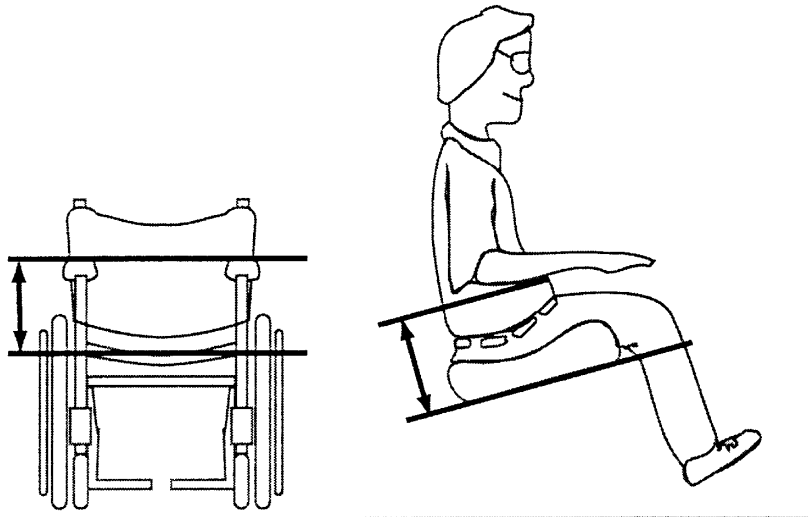

Figure 13 — Armrest height

The armrest height of a wheelchair with a fixed-height armrest is given as a single value. For wheelchairs with adjustable-height armrests, a range of heights is given. Some adjustable armrests have infinite adjustments within the range, while others have a limited number of pre-set height adjustments.

Armrests that are too high can cause your shoulders to be elevated; armrests that are too low can contribute to a slumped posture or even shoulder subluxation in riders without good shoulder muscles. Make sure your armrest height is appropriate to prevent shoulder problems and further complications caused by poor posture. If you use armrests, you may find the following additional measurements helpful.

5.2.6.3 Front of armrest to backrest distance

The distance from the backrest to the front of the armrest is important if you use the armrests to transfer into or out of your chair. If the armrests do not extend far enough forward, they may not provide the support you need. If the armrests are too far forward, they may prevent you from getting close to a desk or table. See Figure 14. This measurement will be slightly longer for a wheelchair with sling upholstery.

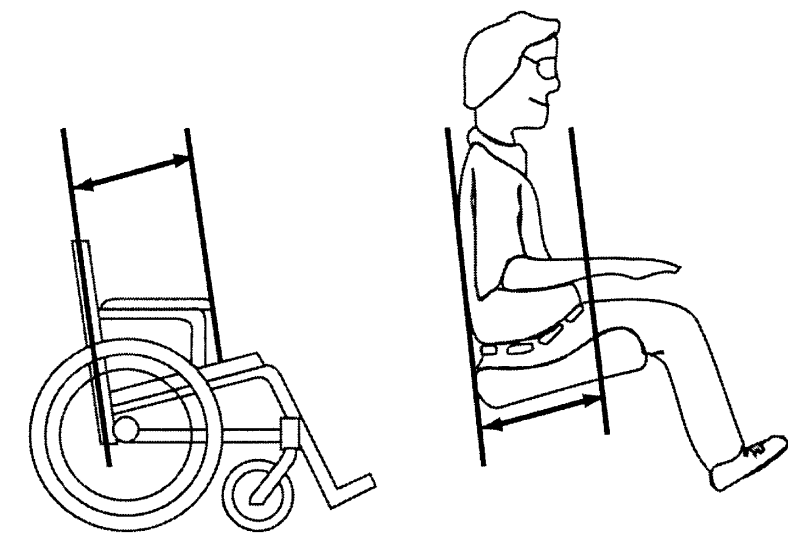

Figure 14 — Front of armrest-to-backrest distance

5.2.6.4 Armrest length

The length of the padded part of the armrest is the armrest length. See Figure 15. When you sit back in the chair, the armrest pad should reach far enough forward from the backrest to support your arm in a comfortable position. If you use a lap tray, the length of the armrests should provide enough support for the tray.

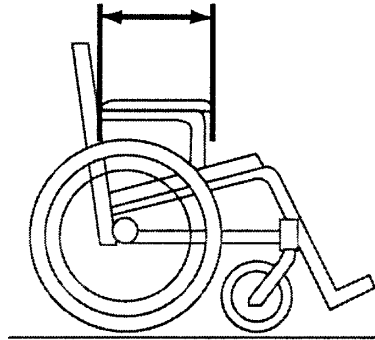

Figure 15 — Armrest length

5.2.7 Front location of armrest structure

The front location of the armrest structure is the distance from the backrest to the most forward part of the armrest. See Figure 16. This distance is measured at a height of about 27 inches from the ground and thus indicates how close you will be able to pull up to a desk or table. The distance from the backrest to the front location of desk-style armrests is shorter because they are specifically designed to enable you to pull up closer to a desk, writing surface or table.

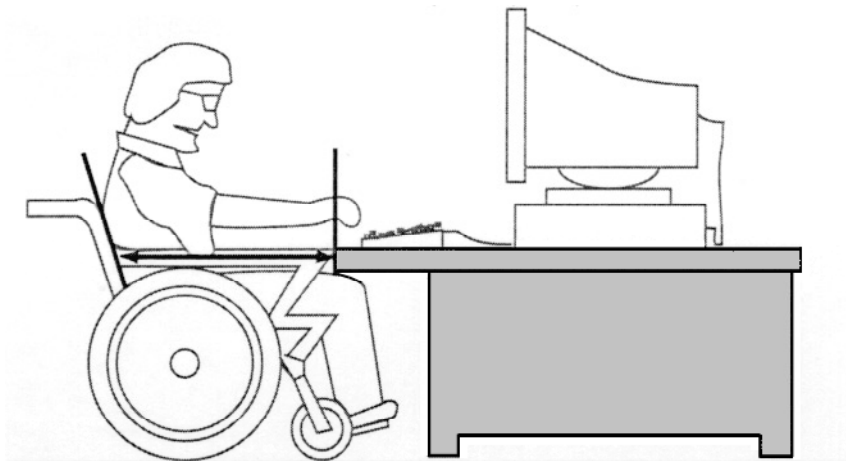

Figure 16 — Front location of armrest structure

5.2.8 Distance between armrest

The distance between the innermost edges of the armrests is only measured on wheelchairs with fixed armrests. See Figure 17. Armrests welded directly to the frame of the chair tend to limit the maximum available seat width at the height of the armrest pads because of the width of the support pads.

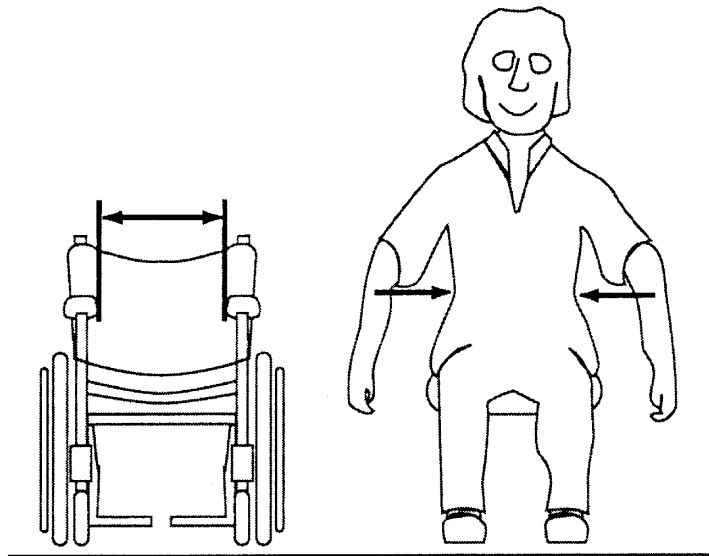

Figure 17 — Distance between armrests

Armrests are available in many styles and sizes. Armrest measurements may vary if you change the type of armrest on the wheelchair. The type of armrest that is best suited for you depends on your size, your needs and your preferences. The armrest features listed in Table 4 may be available from the manufacturer.

Table 4 — Features of armrests

Armrests	Description
Adjustable-height	<ul style="list-style-type: none"> Desirable for setting the armrests at the height you need The height can vary to facilitate transfers
Clothing guard	<ul style="list-style-type: none"> Prevents your clothing and your body from touching the wheel Available in either a fabric or rigid style
Desk-style	<ul style="list-style-type: none"> Shorter armrests that enable you to pull up close to a desk, writing surface, or table
Fixed	<ul style="list-style-type: none"> Cannot be removed from the wheelchair
Full-length	<ul style="list-style-type: none"> Extend at the same height from the backrest forward
Pivoting	<ul style="list-style-type: none"> Can be pivoted into another position (usually behind the back posts) Can be pivoted out of the way for transfers
Removable	<ul style="list-style-type: none"> Can be removed to facilitate transfers
Sloping	<ul style="list-style-type: none"> Slope downward toward the front of the wheelchair Reduced profile for approaching a desk, writing surface, or table
Wraparound	<ul style="list-style-type: none"> Often create a narrower overall wheelchair width without significantly decreasing the width between the armrest panels The rear lock on the armrest may be farther back on the chair and more difficult to reach

5.2.9 Headrest height

If a chair comes with a headrest, International Standards require that the manufacturer disclose how high the centre of the headrest is above the seat upholstery. If the headrest is adjustable, the test results will indicate the range of heights at which it can be positioned. To determine your headrest height, sit on your seat cushion

in a chair with a seating surface like the one you will be purchasing. Measure from the back of your head down to the seating surface beneath your cushion. See Figure 18.

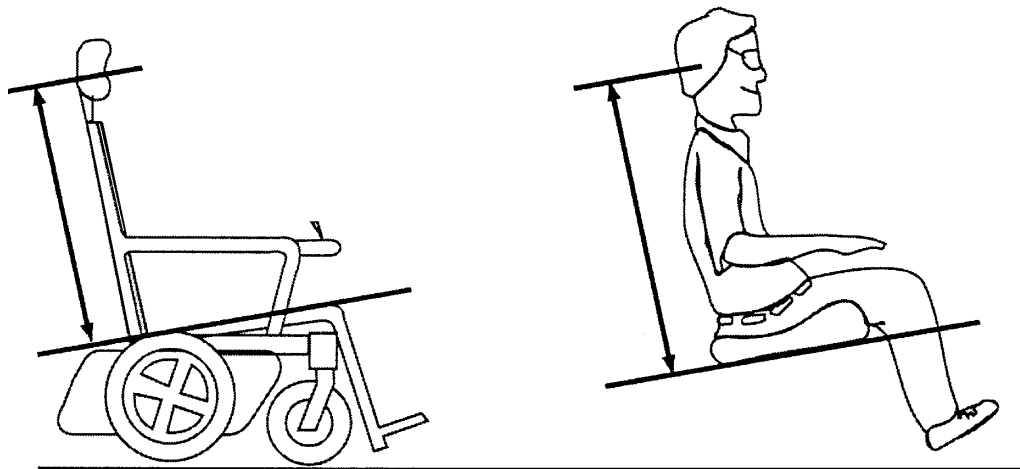

Figure 18 — Headrest height

Another measurement that may be of interest to you is the distance the headrest is in front of the backrest. Manufacturers are not required to disclose this measurement in the pre-sale technical product literature, but you can request it. This measurement will indicate if the headrest is directly in line with the backrest or if it can be positioned in front of or behind the backrest. It may be a single value or, if the headrest position is adjustable, a range of values.

5.3 Joint flexibility

5.3.1 General

In addition to your size, the flexibility of your joints (how far your arms and legs bend and straighten) will influence the fit of your chair. Your ability to maintain your sitting balance will also affect your choice.

The flexibility of your hips affects the seat-to-backrest angle you need. In International Standards, the seat-plane angle refers to the slope of the seat. Some riders have found that wedged or squeeze frames (chairs with a rearward slope to the seat) help with balance and stability. If you keep your backrest upright (not reclined) and increase the rearward slope of your seat, you will need to bend your hips more to fit into the chair. If you do not have good hip flexion, too much squeeze can cause pressure problems because your body cannot bend enough to fit into the chair.

If you are not very flexible, you may want to look for a chair with an adjustable backrest angle. If you recline the backrest just a little, the angle between the seat and the backrest will more closely match the angle between your thigh and your trunk.

Some powered wheelchairs are available with a power recline feature. This option may be necessary if you must perform independent weight shifts and repositioning for increased sitting tolerance and cannot shift weight by yourself. A power recline feature can also eliminate the need for transfers to bed for rest or catheterisation. Quick position changes can help reduce spasticity, your body's response to low blood pressure, and dysreflexia.

It is also important to know the flexibility of your knee and ankle joints. Many wheelchair manufacturers offer chairs with the foot pedals closer to the front edge of the seat. These "tighter" footrests reduce the overall length of the chair and make it easier to get closer to things in your environment. To fit into these tighter wheelchairs, you need good knee flexion.

5.3.2 Leg-to-seat surface angle

The smaller the leg-to-seat surface angle, the more flexion or bend you will need at your knees. If you have limited knee movement, look for the angle that most closely matches the angle between your thigh and lower leg. See Figure 19.

NOTE Many wheelchair manufacturers used to measure this angle using a different method. They were not measuring the leg-to-seat surface angle as illustrated here. When this angle is measured correctly, it will almost always be greater than 90°.

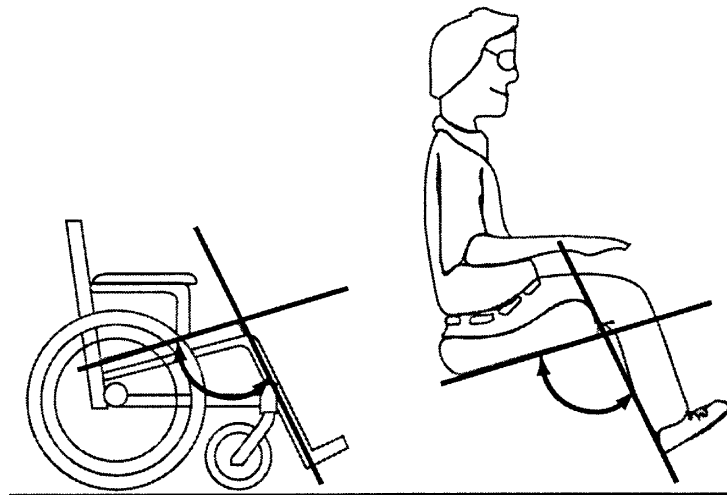

Figure 19 — Leg-to-seat surface angle

5.3.3 Seat-plane angle

The seat-plane angle can be positive, negative or zero. A zero seat-plane angle means that the seat is level. A positive seat-plane angle means that the seat slopes downwards to the rear and that the front edge of the seat is higher than the back edge. Seats with a positive seat-plane angle require good hip flexion. A negative seat-plane angle means that the seat slopes forwards and the front edge of the seat is lower than the back edge. Seats with a negative seat-plane angle require good trunk balance. See Figure 20.

Some wheelchair users like sitting with their knees up high on a wedge to increase their trunk stability. However, while doing this increases trunk stability in the short term, it tends to round your spine and, in the long term, can lead to back pain.

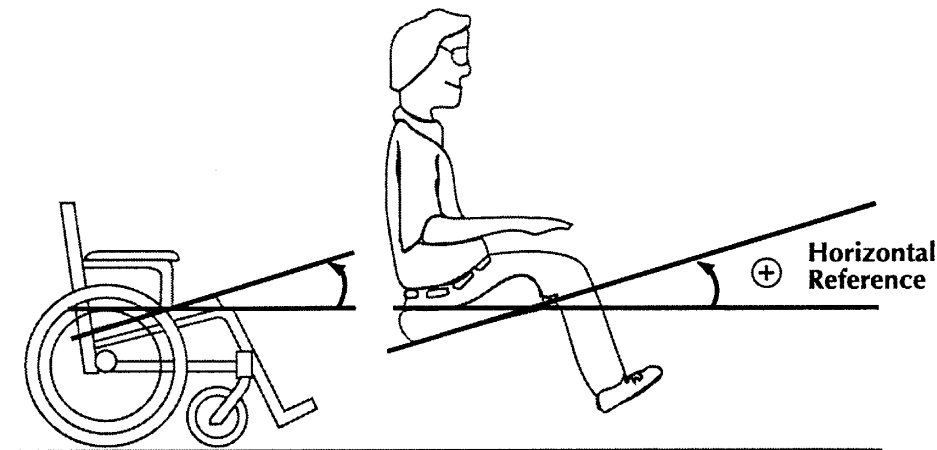

Figure 20 — Seat-plane angle

5.3.4 Backrest angle

A zero backrest angle means that the backrest is upright or vertical. A positive backrest angle means that the backrest is reclined. See Figure 21. Backrests that can be reclined quite far have large positive angles. The larger the angle, the more you will lean back in your wheelchair. A reclined position accommodates less flexible hips. Backrests that can be adjusted into a forward-leaning position have negative backrest angles. A forward-leaning backrest requires greater hip flexion. The more vertical the backrest angle, the more you will sit up straight in your wheelchair. Some wheelchair users like sitting in a chair with a negative backrest angle. If the backrest angle is adjustable, the manufacturer will give a range of angles.

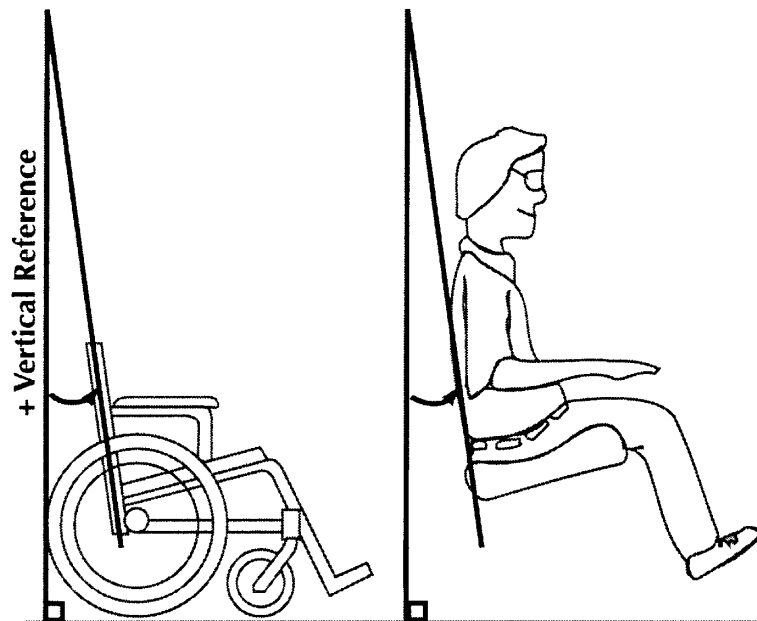

Figure 21 — Backrest angle

5.4 Propulsion skill

5.4.1 General

Wheelchair handrims are usually mounted on the rear wheels. How easily you can reach the handrims greatly affects your ability to propel the chair. Three standard measurements can help you determine how well you will be able to propel the wheelchair:

- the propelling wheel diameter,
- the handrim diameter, and
- the horizontal location of the rear axle.

5.4.2 Propelling wheel diameter

Most chairs have a 24 inch diameter propelling wheel and a slightly smaller handrim (pushrim), usually 20 inches to 21 inches in diameter. For many users, these wheel and handrim sizes put the top of the handrim in a good position to push. However, if you sit very high or very low in the chair, or if you have very long or very short arms, you may want smaller or larger wheels. Smaller wheels are more efficient if you have longer arms, because you do not have to bend your elbow and shoulder as much to reach the top of the handrim. Conversely, larger wheels (26 inches or 28 inches in diameter) bring the wheel closer to your hand if you have short arms or need to sit higher in the chair (for example, for proper ground clearance under the foot pedals). Bringing the handrim closer to the arms also helps if you have limited arm movement.

5.4.3 Handrim diameter

Many riders who race wheelchairs have found that a smaller handrim (pushrim) diameter increases the effectiveness of the pushing stroke. They can maintain contact on the handrim while pushing down and back with their arms during the propulsion phase of the stroke. Using a long stroke with a complete follow-through maximizes speed. This may not be practical in everyday propulsion, but you may want to experiment with smaller handrims to determine the handrim diameter that matches your propulsion needs.

Smaller handrims may increase your risk of injury during activities of daily living, and they require more strength to propel the wheelchair. For a small amount of handrim movement, the wheelchair moves a lot, like using a high gear on a bicycle. Also, to reach smaller handrims, you must sit very low, which may not be practical in an everyday wheelchair.

5.4.4 Horizontal location of the axle

In addition to the size of the propelling wheel, the fore-aft (horizontal) location of the wheel affects how easily you can reach the handrim. The horizontal location of the axle is the position of the wheel relative to the rider. See Figure 22. A positive value indicates that the wheel is mounted in front of the intersection of the backrest and seat planes. A negative value means that the rear wheel axle is located behind the intersection. A range of values indicates that the wheel can be moved within that range. Adjusting the axle position usually requires tools to unbolt the sockets into which the quick-release axles plug.

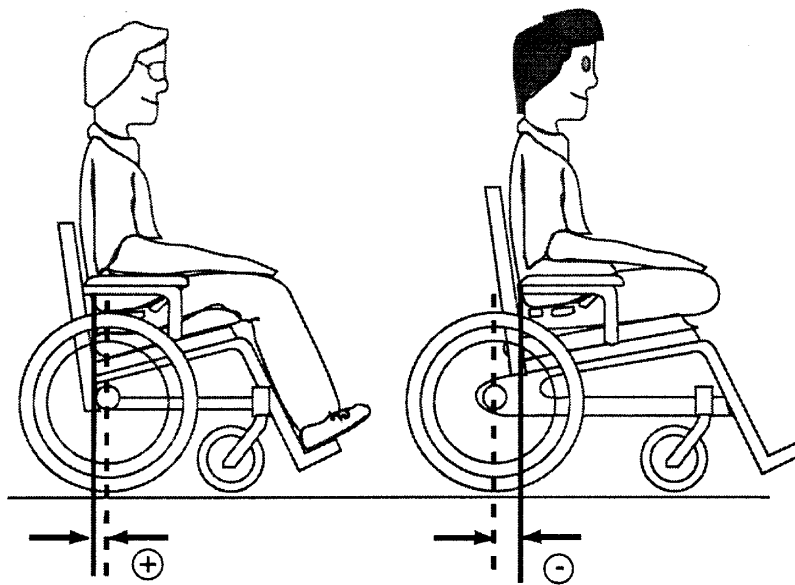

Figure 22 — Horizontal location of the axle

5.4.5 Advantages and disadvantages of different wheel placements

A forward-mounted wheel may be easier to reach, but the user will need good wheelchair mobility skills, because the chair will tip backward more easily. This chair also will be easier to get into a wheelie. Another advantage of a forward-mounted wheel is a reduced wheelbase, which allows you to get around in tight quarters. Also, the wheelchair will have less tendency to turn downhill on a side slope. Finally, the rear wheels will have greater traction since a greater percentage of your weight is riding on them.

If the horizontal axle position is far back, the wheelbase length will be increased, and it will be more difficult for you to reach the wheels. However, the rear stability of the chair will be increased. A more stable chair is harder to get into a wheelie, but is less likely to tip backward. There may be an increased tendency for the wheelchair to turn downhill when travelling across a side slope, and there will be less traction on the rear

wheels, which will reduce stopping ability. With the wheels mounted toward the rear, forward tipping can become a problem as well. Many wheelchair accidents are related to forward tipping.

For amputees, having the drive wheels farther back is essential since the lack of weight on the front of the wheelchair can make it very unstable.

Because many wheelchairs have adjustable rear axle positions, it is possible to move the axle forward as you become more experienced with using the wheelchair.

6 Manual wheelchairs

6.1 Performance

6.1.1 General

There are hundreds of manual wheelchairs on the market today. As you begin the process of comparison shopping, you will want to know exactly how your wheelchair will perform. The International Standards on wheelchairs address four aspects of the wheelchair that affect its performance:

- a) mass (weight),
- b) stability,
- c) durability-fatigue strength, and
- d) manoeuvrability.

For these performance tests, the manufacturer gives the results as specific values. There are no minimum performance values, therefore no wheelchair fails these tests. If the chair tips over backwards on a slope of only 1°, that is what is reported. It will be up to you to determine if the wheelchair's performance is compatible with your abilities, lifestyle and environment.

Until you understand exactly what these performance values mean, your experience with using a particular wheelchair will help you understand how other wheelchairs will perform. By comparing test results, you will learn how other wheelchairs perform compared with the wheelchair you currently use. The information provided by these tests will enable you to make true comparisons among wheelchairs, because each chair will be tested the same way.

6.1.2 Mass (weight)

6.1.2.1 How heavy is the chair?

Whether you prefer a tank-style chair or a super lightweight chair, you will want to know and compare the weights of several different chairs. The weight of the chair may also be important if you need to stow it in the back of your car when you drive, or if the person assisting you needs to lift the chair into and out of the trunk. See Figure 23.

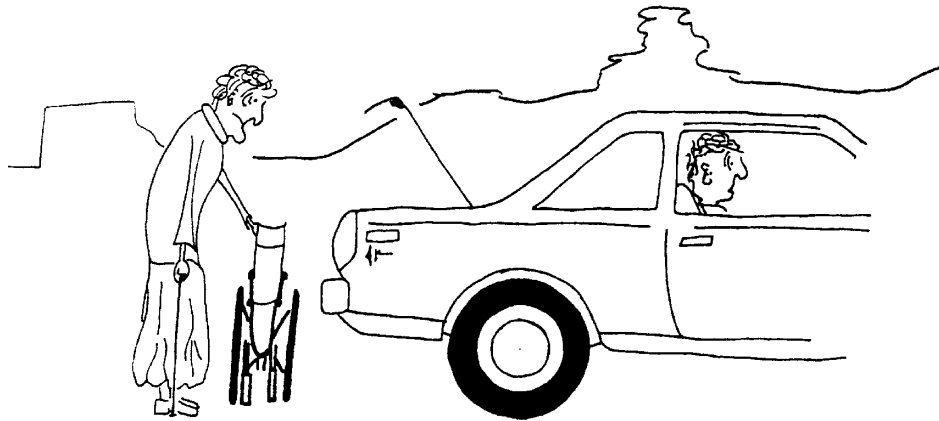

Figure 23 — The weight of your wheelchair is not just an issue for you as the rider

6.1.2.2 Determination of mass

A test procedure is given in ISO 7176-5:1986, *Wheelchairs — Part 5: Determination of overall dimensions, mass and turning space.*

The total mass of the wheelchair equipped with standard armrests, legrests, wheels and castors is measured.

Disclosure format (as reported by manufacturers)

Name of test	Test result
Total mass of wheelchair with accessories	___ kg (___ lb)

Additional information not required for disclosure in the product literature:

Mass of each removable component of the wheelchair	___ kg (___ lb)
--	-----------------

6.1.2.3 Interpretation of results — Mass

The results of this test procedure help you to compare wheelchairs manufactured by different companies. Using these results, you will be able to identify the lightweights and the heavyweights. Most importantly, you will be able to find the chairs that fall within the weight range you desire. This information indicates how the wheelchair will perform and whether you or the person assisting you will be able to load it into a car.

Knowing the weight of each removable component of the wheelchair may also help in your selection process. If fully equipped wheelchairs (with standard armrests, legrests, wheels and castors) are too heavy to lift, you may choose a wheelchair based on the weight of the heaviest component, which is usually the frame. This information is not required for disclosure in the product literature, but it is available upon request from the manufacturer. Using the weights of the wheelchair and each of the components, you can calculate the weight of the chair equipped the way you like it.

One component that significantly changes the weight of the wheelchair is the main drive wheels. Depending on the chair, either spoke or mag wheels are standard. In general, spoke wheels are lighter, but they require more maintenance, since the spokes can become loose or break. Mag wheels are heavier but are virtually maintenance free. The tyre you choose also can make a difference to the weight. A lightweight, Kevlar-reinforced tyre with a thin tube can be significantly lighter than a heavy rubber tyre with a thick-walled tube. Your own body weight represents a large percentage of the combined weight of the wheelchair and rider. Therefore, shaving off a pound here and there on the wheelchair may not result in a significant difference in wheelchair performance, but it may be necessary if you need to load it into your car.

6.1.3 Stability

6.1.3.1 How tiltable is the chair?

Let's face it, the world is not flat. Hills, ramps, dropped kerbs and sidewalks with side slopes are just a few of the reasons you might want to know how tiltable your wheelchair will be. The stability of the wheelchair standing still not only indicates how tiltable the chair is when at rest; it also indicates how stable the chair will be when it is moving. If you have a lot of rider experience or are very active, you may prefer a chair that tips back into a wheelie position with just a slight shift of your weight. If you do not have much experience or upper body mobility, you may want a more stable, less tiltable chair.

6.1.3.2 Determination of stability

A test procedure is given in ISO 7176-1:1999, *Wheelchairs — Part 1: Determination of static stability*.

The wheelchair is placed on a standardized test surface with a weighted test dummy positioned in the chair. The test surface is tilted with the wheelchair facing uphill, downhill and sideways. The angle at which the wheels of the wheelchair lift off the test surface is recorded in degrees.

See Figure 24.

Disclosure format (as reported by manufacturers)

Name of test	Test result
Facing downhill/brakes on: tips at	___ degrees of slope
Facing uphill/brakes on: tips at	___ degrees of slope
Facing sideways/brakes on: tips at	___ degrees of slope
Other critical direction/brakes on: tips at	___ degrees of slope

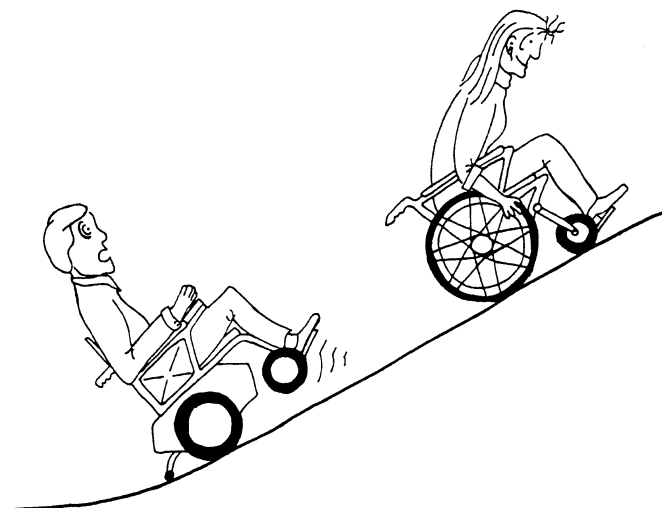

Figure 24 — Having the ability to lean forward in your wheelchair allows you to negotiate steeper ramps

6.1.3.3 Interpretation of results — Stability

During the test, the wheel locks are engaged, simulating you, the wheelchair rider, holding onto the handrims on an incline. The best way to create the same effect during testing is to apply the wheel locks.

The smaller the uphill tip angle, the more easily tiltable is the wheelchair. This means that the chair will start to tip when the platform is tilted a small amount. A wheelchair that tips more easily will be easier to manoeuvre and will have less tendency to turn downhill on side slopes. Because a larger percentage of your weight is on the rear wheels, the wheelchair will have greater traction. However, the wheelchair will be less stable and more likely to tip over backwards when you go uphill unless you can adjust your body weight by leaning forward. When your body weight is over the main drive wheels of your wheelchair, the chair is easily tiltable. When you shift your weight forward (either by leaning forward or by moving the main drive wheels back) you make the wheelchair less tiltable.

Conversely, a greater uphill tip angle means that the platform will be tilted more before the chair's wheels lift off the platform. Chairs with larger tip angles are less tiltable, harder to manoeuvre, and have a greater tendency to turn downhill on side slopes. Less weight is distributed over the rear wheels, which may result in rear wheel slippage when you go down an incline.

A chair with a smaller downhill tip angle is less stable going forwards. During testing the platform is tilted, raising the back end of the wheelchair. This simulates a wheelchair facing downhill. When you travel down ramps and dropped kerbs, you may need to lean back in the chair to prevent it from tipping forward. Unless you have good balance and a low-back chair, you may not be able to lean back in the wheelchair. If you cannot lean back in the chair, you should probably consider a chair that is more stable in the forward direction: one with a greater downhill tip angle.

If the manufacturer reports a range of tip angles, this indicates that the position of the rear wheel, front castor and/or other features is adjustable. Some wheelchairs have only distinct vertical and/or horizontal positions in which the main drive wheels can be located. Other chairs offer an infinite number of horizontal axle positions. Adjusting the rear wheel forwards will decrease the wheelbase and will decrease the stability of the chair in the rearward direction. Moving the rear wheel backwards will increase the wheelbase and consequently increase the rearward stability of the chair. Changing the vertical position of the rear wheel changes the seat height and angle and can either increase or decrease stability, depending on the location of the centre of mass of the system. The fore-aft adjustment of the castor, if available, changes the length of the wheelbase. The smaller the wheelbase, the more tiltable is the chair in either the forwards or backwards direction. Many users change to a more easily tiltable wheelchair as they gain more rider experience.

A chair with a smaller sideways tip angle is less stable side to side. A chair with a smaller sideways tip angle is more likely to tip over sideways when you travel across surfaces with steep cross slopes or lean over the side of the chair.

A range of sideways tip angles usually indicates that the amount of camber is adjustable. Camber is the angling of the main drive wheels out at the bottom of the chair. Some manufacturers allow users to customize their chair by changing the camber. Increasing the camber will make a wheelchair more stable from side to side but will also increase the overall width of the chair and make it difficult to get through narrow doorways. Camber also moves the pushrims in closer at the top of the main drive wheels, which will enable you to reach your pushrims easier and may actually prevent you from hitting your fingers as you pass through doorways. See Figure 25.

Remember that the tip angle is not an indication of the quality of the wheelchair, but a matter of personal preference.

To give you an indication of the angles of the slopes you may encounter in public places, accessible environments that comply with the Americans with Disabilities Act Accessibility Guidelines (ADAAG) will not have slopes greater than 1:12 (4,8°). Therefore, a wheelchair with an uphill tip angle of greater than 5° will probably not tip backwards when you climb a public ramp, especially if you can lean forwards in the wheelchair. If, however, the downhill tip angle is close to 5°, you may end up performing somersaults while trying to wheel down the ramp, unless you can shift your body weight by leaning backwards.

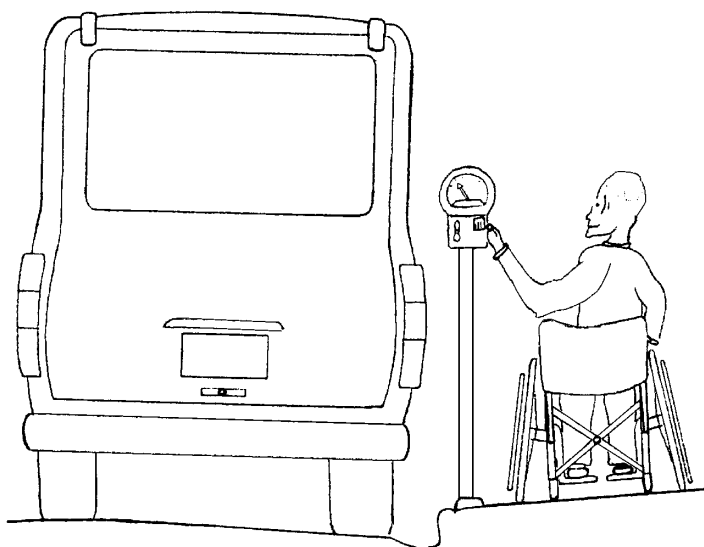

Figure 25 — Extra camber on your wheelchair makes your chair a little more stable on cross slopes and moves the handrims a little closer in on the sides

The disclosed test results apply only to the wheelchair as tested by the manufacturer. If you want different main drive wheels or castors, the stability of the chair may change. For example, smaller diameter rear wheels or larger front castors will tilt the wheelchair to the rear and possibly decrease its stability going uphill.

Anti-tippers are extra little wheels designed to prevent a wheelchair from tipping over backwards. They will affect the stability of the chair when going uphill. Although anti-tippers prevent the wheelchair from tipping, many riders do not like using them. They restrict the chair's ability to go over obstacles, because they can get caught on the obstacle. In addition, it is almost impossible for the wheelchair rider to adjust anti-tippers from the down/engaged position to the up position or vice versa while sitting in the wheelchair because they are difficult to reach. See Figure 26.

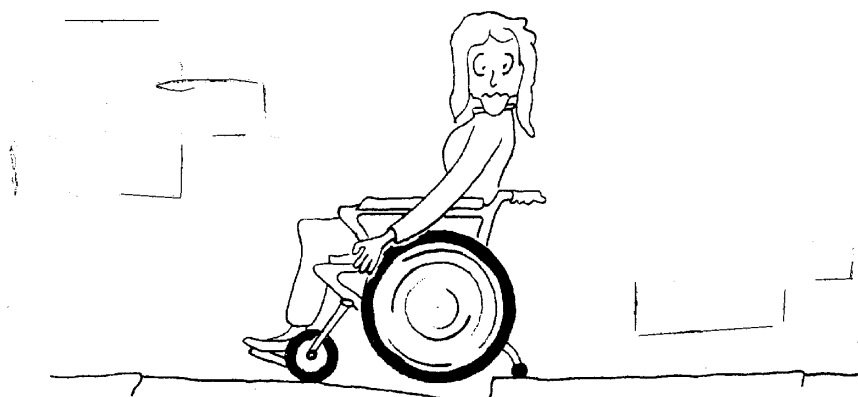

Figure 26 — Anti-tippers can literally leave you spinning on your wheels

6.1.4 Durability — Fatigue strength

6.1.4.1 How long will the wheelchair last?

A wheelchair is a major purchase; the last thing you want is a chair that falls apart after a week of taking it over bumps, up and down kerbs, in and out of the car, and through all the other activities you do in your chair every day. How long will a wheelchair last? The durability of the chair is important, whether you are a very active rider or not. If a wheelchair component breaks, you could be hurt or stranded somewhere. Fatigue tests are intended to determine the durability of the wheelchair and its components by subjecting them to a large number of low-level stresses, similar to the forces the chair is subjected to in daily use.

6.1.4.2 Durability — Determination of fatigue strength

A test procedure is given in ISO 7176-8:1998, *Wheelchairs — Part 8: Requirements and test methods for static, impact and fatigue strengths*.

The wheelchair, loaded with the test dummy, is positioned on a double-drum fatigue test machine. This machine consists of two cylindrical drums that are rotated by an electric motor. The wheelchair is placed on these cylindrical drums and it rolls as the drums turn. Slats attached to the drums cause the chair to bump as it rolls. One cylinder turns more quickly than the other, making the bumping uneven. This bumping simulates a user riding over rough ground. The chair rolls on the cylinder for a set number of cycles.

A second fatigue test is the kerb drop test. In the kerb drop test, the loaded wheelchair is dropped in a free-fall manner from a height of approximately 2 inches. One kerb drop fatigue test is performed for every 30 cycles on the double-drum fatigue test machine. The manufacturer is asked to disclose the number of double-drum and kerb drop cycles that the wheelchair completes without failure.

Disclosure format (as reported by manufacturers)

Name of test	Test result
Double-drum test	___ cycles
Kerb drop test	___ cycles

6.1.4.3 Interpretation of results — Durability

If the manufacturer discloses that its chair has been tested with a large number of double-drum and kerb drop cycles, it means that the chair is more durable than one that only passed a smaller number of test cycles. However, if the manufacturer discloses that its chair has been tested to a smaller number of double-drum and kerb drop cycles, it may only mean that they stopped testing after that many cycles. Unfortunately, the test procedures do not require the manufacturers to test their wheelchairs until they fail. The manufacturers are only required to disclose how many cycles the wheelchair completed without failure.

During fatigue testing the entire wheelchair (frame, seat upholstery, wheels and all other components) is subjected to a large number of stresses. The composition and construction of each of these components affects the durability of the wheelchair. When a major component of the chair fails, the testing is terminated. If a bolt comes loose or an adjustment needs to be tightened, the testing is continued until a major component failure occurs.

See Figure 27.

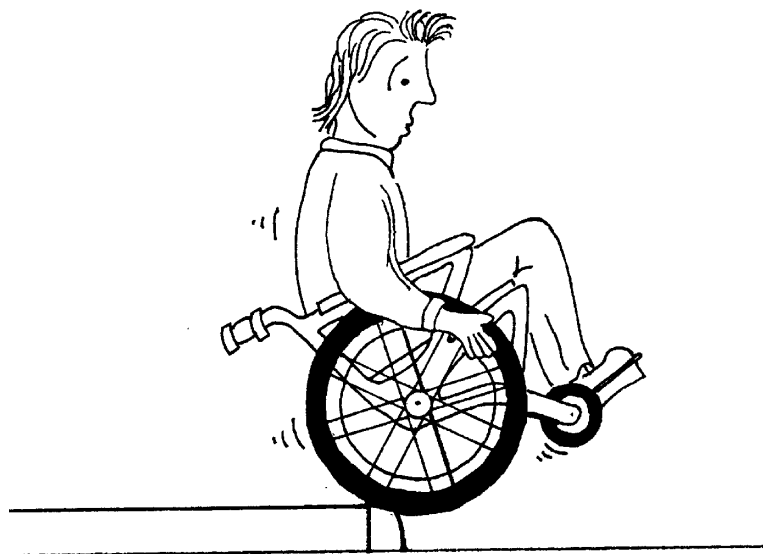

Figure 27 — You want to know that your chair will hold up to the sort of use it sees from day to day

6.1.4.4 Frame materials

While many components can be replaced for a small fraction of the cost of the wheelchair, the frame cannot, because of the cost of frame construction. Wheelchair frames are usually made from mild steel, stainless steel, chromoly steel, aluminium, titanium or a composite. A wheelchair constructed from one type of material is not necessarily more durable than one constructed from another. Although each material has a specific amount of strength per mass of material (strength-to-mass ratio), wheelchair designs vary so much that you cannot determine the durability of the product solely by the material used. The frame tubing thickness, tubing shape, welding technique, and how the components are assembled together, are just a few of the factors affecting the fatigue strength of the chair.

While the type of frame material may not indicate how long the chair will last, it does provide some other helpful information. See Table 5.

Table 5 — Characteristics of frame materials

Frame material	Advantages	Disadvantages
Mild steel	<ul style="list-style-type: none"> • Easily repaired and welded in places where high-technology welding equipment is not available • Moderate strength-to-mass ratio 	<ul style="list-style-type: none"> • Relatively heavy
Stainless steel	<ul style="list-style-type: none"> • Highly resistant to corrosion 	<ul style="list-style-type: none"> • Lower strength-to-mass ratio than other steels
Chromoly steel	<ul style="list-style-type: none"> • High strength-to-mass ratio • Essentially a high-technology steel 	<ul style="list-style-type: none"> • More expensive than mild steels
Aluminium	<ul style="list-style-type: none"> • High strength-to-mass ratio 	<ul style="list-style-type: none"> • More expensive than mild steels
Titanium	<ul style="list-style-type: none"> • Very high strength-to-mass ratio • Highly corrosion resistant 	<ul style="list-style-type: none"> • Very expensive
Composite	<ul style="list-style-type: none"> • High strength-to-mass ratio • Ability to form nonconventional shapes 	<ul style="list-style-type: none"> • Surface finish chips easily

6.1.4.5 Frame finish

The way the frame of the chair is chemically prepared, primed and painted will affect the durability of the finish. Getting paint to adhere to stainless steel is difficult, and it is almost impossible for titanium. Composite materials are covered with coloured gel coat or painted, but these finishes can chip. Steel and aluminium can be finished with various standard processes. One of the best processes is powder coating. This finishing process minimizes paint waste and results in a durable finish.

6.1.4.6 Castors

Both the size and the type of castor affect the durability of the wheelchair. During the double-drum test, the slats on the cylindrical drum constantly hit the castors, and the forces generated are transferred to the rest of the chair. This is similar to what occurs when you ride over obstacles or uneven terrain (e.g. door thresholds, sidewalk cracks). Because the castors are the first part of the wheelchair that contacts the obstacles and because of their small diameter, they take a substantial beating. Large pneumatic castors can absorb these forces better than small solid castors and can cushion the wheelchair, causing less wear and tear on other wheelchair components.

6.1.5 Manoeuvrability

6.1.5.1 How much space does the wheelchair need to turn around?

You have probably created a home or office environment that allows you as much access as possible in your current wheelchair. Try to make sure your new wheelchair does not create new architectural barriers because its turning radius is larger than that of your current chair. On the other hand, you may want to improve your access so you can manoeuvre more easily in hotel rooms, small apartments, tight office spaces, narrow dormitory hallways, bathrooms, or those ridiculously small public toilet stalls.

6.1.5.2 Determination of manoeuvrability

A test procedure is given in ISO 7176-5:1986, *Wheelchairs — Part 5: Determination of overall dimensions, mass and turning space*.

In order to measure turning space, an adjustable corridor is created and a three-point turn manoeuvre is performed. The corridor is narrowed until the wheelchair is unable to perform the manoeuvre. The minimum corridor width in which the chair can turn is disclosed. See Figure 28.

Disclosure format (as reported by manufacturers)

Name of test	Test result
Minimum turnaround width	___ mm (___ inches)

Additional information not required for disclosure in the product literature:

Minimum turning radius	___ mm (___ inches)
------------------------	---------------------

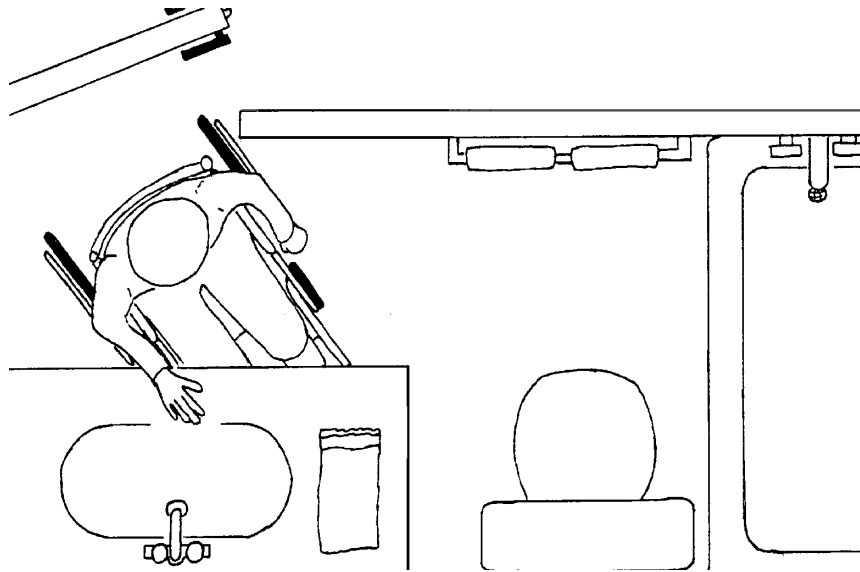

Figure 28 — An extra inch can mean a lot in a small bathroom

6.1.5.3 Interpretation of results — Manoeuvrability

The results of this test are essential if you live or work in an environment with tight spaces. If there is a particularly narrow hall or space at home, work or school, measure its width and search for chairs that can perform a three-point turn in spaces that size or smaller. Remember that footrest assemblies can be removed, if necessary, to improve the chair's ability to turn around in tight places. The size of the castor can also increase or decrease the wheelchair's manoeuvrability. Smaller castor wheels swivel more easily without hitting your feet.

Once you have limited your choice to a few chairs, you may want to check the turnaround space for each of the chairs to make sure they will be able to get you through or into and out of any tight spots in your home.

6.2 Safety

6.2.1 General

Most of the time you have full control of your chair. At times, however, either when you need assistance from someone else or because of careless or reckless riding, the chair may be exposed to damaging forces or unsafe conditions. To ensure against an unsafe wheelchair design, the following tests subject the chair to forces or conditions that could result in a hazardous situation. The test results are either pass or fail. Test outcomes that place the rider at risk are recorded as a failure.

International Standards on wheelchairs address the following areas of manual wheelchair safety:

- static and impact strength,
- flammability, and
- wheel locks.

The strength of a manual wheelchair includes static and impact strength testing. Static tests determine the strength of the wheelchair and its components under high-stress loads that may occur only occasionally, such as the loads exerted on the armrests when you do a push-up. Impact tests determine the strength of the wheelchair and specific components under conditions of impact loading, such as striking an obstacle with the footrests or castors or dropping part or all of the wheelchair.

6.2.2 Static and impact strength

6.2.2.1 How strong is the wheelchair?

Every day you subject your wheelchair to stresses, and you want to know which wheelchairs will be able to withstand these various stresses. Not everyone is a perfect wheelchair driver. There will be times when you or the person assisting you runs into a doorway frame or other barrier with your castor, footrest or wheel. A simple bang of the handrim on the doorway frame could lead to a dent or a burr in the metal that could cut your hand the next time you grab the handrim to stop. You may find yourself in a situation in which you need to be pulled up stairs, and those lifting may grab the armrests and footrests of your wheelchair. To be safe, armrests and footrests should either pull right out or they should support the weight of you and your chair. Armrests must also be able to support your weight when you do push-ups.

See Figure 29.

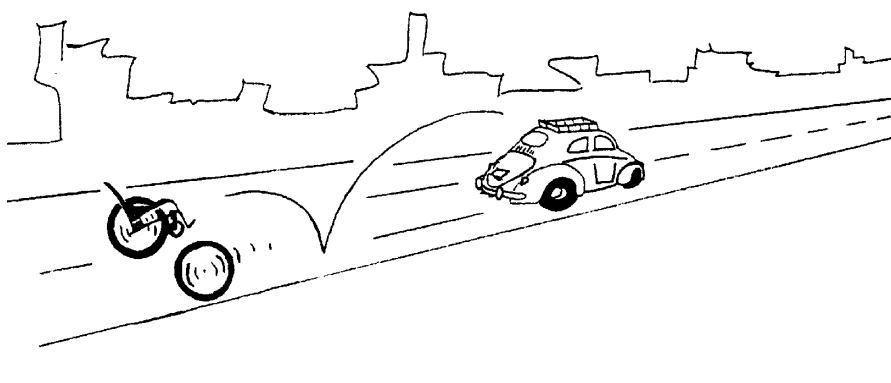

Figure 29 — Your wheelchair will not necessarily survive all types of mishandling; however, you would like your chair to show up at the end of a plane flight in one piece

6.2.2.2 Determination of static and impact strength

A test procedure is given in ISO 7176-8:1998, *Wheelchairs — Part 8: Requirements and test methods for static, impact and fatigue strengths*.

Static strength tests are intended to determine the strength of the wheelchair and its components under particular high-stress loads that may occur only occasionally. Using a standardized loading pad or strap, a large force is applied once to the relevant part of the wheelchair. If a structural failure, deformation and/or maladjustment of any part of the wheelchair occurs, it does not pass the test.

Impact strength tests are intended to determine the strength of the wheelchair and specific components under conditions of impact loading. Impact tests are conducted by dropping a weighted ball against part of the wheelchair, by running the wheelchair into an obstacle, or by dropping all or portions of the wheelchair on the ground. If the impact results in a structural failure or deformation of part of the wheelchair that adversely affects its function, the wheelchair does not pass the test.

A pass or fail result indicates whether or not the wheelchair was functional after a known force was applied. The manufacturer may choose to test the wheelchair at higher forces or higher drop heights and may disclose the results.

Disclosure format (as reported by manufacturers)

Name of test	Test result
Static strength tests	pass/fail
Impact strength tests	pass/fail

6.2.2.3 Interpretation of the results — Static and impact strength

See Tables 6 and 7.

Table 6 — Results of static load tests

Static load test	Requirements for pass	Disclosure format
Armrest downward	<ul style="list-style-type: none"> The armrest can still be removed and adjusted after a push-up. 	pass/fail
Footrest downward	<ul style="list-style-type: none"> The footrest returns to its original condition and can still be flipped up, swung away, or removed and reinstalled after a person extends or does a weight shift. 	pass/fail
Tipping levers downward	<ul style="list-style-type: none"> The tipping lever will not be deformed when a person steps on the lever to tilt the wheelchair backward. 	pass/fail
Hand grip	<ul style="list-style-type: none"> The handgrips will not slip off when a person pulls you and your wheelchair up or down steps. 	pass/fail
Armrest upward	<ul style="list-style-type: none"> If the wheelchair is lifted by the armrests, the armrests will either lift out of the socket before the chair is lifted off the ground or the armrests will be able to support the weight of the wheelchair and you, allowing you to be lifted up or down safely. 	pass/fail
Footrest supports upward	<ul style="list-style-type: none"> If the wheelchair is lifted by the footrests, the footrests will either lift out of the socket before the chair is lifted off the ground or the footrests will support the weight of the wheelchair and you, allowing you to be lifted up or down safely. 	pass/fail
Push handle(s) upward	<ul style="list-style-type: none"> The push handles support the weight of the wheelchair and you and can be used to safely lift you and your chair off the ground. 	pass/fail

Table 7 — Results of impact load tests

Impact load test	Requirements for pass	Disclosure format
Seat	<ul style="list-style-type: none"> The seat will not rip when you flop into the chair. 	pass/fail
Backrest	<ul style="list-style-type: none"> The backrest will hold you when you fall back against it. 	pass/fail
Drop test	<ul style="list-style-type: none"> The chair will still open and roll if someone drops it while unloading it from the boot (trunk) of the car. 	pass/fail
Rolling – wheels and/or castors	<ul style="list-style-type: none"> The front wheels or castors will not deform when the wheelchair hits a kerb or pothole in the pavement. 	pass/fail
Footrest	<ul style="list-style-type: none"> The footrest will not bend when you hit a kerb. 	pass/fail
Armrest drop	<ul style="list-style-type: none"> The armrest will still fit on the chair after it is dropped on the floor. 	pass/fail
Loaded drop	<ul style="list-style-type: none"> The rear wheel will not bend if the chair is dropped off a kerb onto one wheel. 	pass/fail

If the wheelchair passes all the static load tests, it will probably not fail under the conditions listed above, and the wheelchair components will still be adjustable and removable. If the wheelchair passes all the impact tests, you know that there was no change in its structure or function after the impacts.

6.2.3 Flammability

6.2.3.1 Will the wheelchair go up in flames if I smoke in my chair?

If you, your friends, or co-workers smoke, you should not overlook the results of this test. A cigarette dropped onto the wheelchair upholstery could ignite the chair.

6.2.3.2 Determination of flammability

A test procedure is given in ISO 7176-16:1997, *Wheelchairs — Part 16: Resistance to ignition of upholstered parts — Requirements and test methods*.

The test procedure is performed in accordance with ISO 8191-1:1987, *Furniture — Assessment of the ignitability of upholstered furniture — Part 1: Ignition source: smouldering cigarette*, and ISO 8191-2:1988, *Furniture — Assessment of ignitability of upholstered furniture — Part 2: Ignition source: match-flame equivalent*. These are pass or fail tests.

Disclosure format (as reported by manufacturers)

Name of test	Test result
Resistance to ignition	pass/fail

See Figure 30.

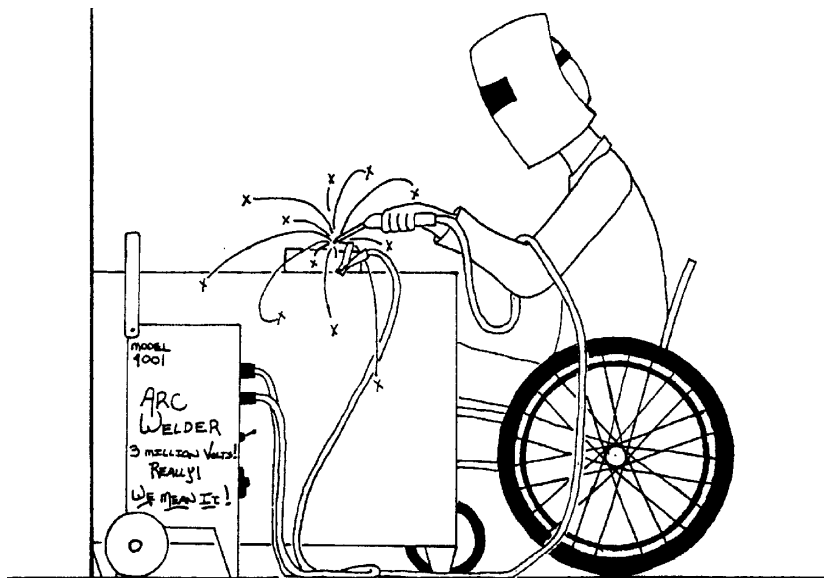

Figure 30 — Flammability is not just an issue related to cigarette smoking

6.2.3.3 Interpretation of results — Flammability

This test applies only to the upholstery supplied by the wheelchair manufacturer, not to any cushions that you add to the chair. A lit cigarette should only smoulder; it should not cause the upholstery to ignite. Cushions and supports added after purchase may not have been subjected to the flammability test. If you are a smoker or you spend time with people who smoke, then you should choose a wheelchair that passes this test.

6.2.4 Wheel locks

6.2.4.1 How effective are the wheel locks?

Wheel locks are supposed to keep the main wheels from turning. Some people refer to wheel locks as brakes. If you stop on a ramp to chat with a friend or take something out of your backpack, you may not think twice about engaging the wheel locks and using your hands for other tasks. If you stop on a slope, the wheel locks should prevent you from rolling downhill.

6.2.4.2 Test on wheel locks

A test procedure is given in ISO 7176-3:2003, *Wheelchairs — Part 3: Determination of effectiveness of brakes*.

The wheelchair, with the wheel locks engaged, is placed on a standardized test surface with a test dummy positioned in the chair. The surface is tilted with the wheelchair facing uphill then downhill. The angle at which the wheelchair begins to roll, slide or tip is disclosed.

Disclosure format (as reported by manufacturers)

Name of test	Test result
Parking brake test facing downhill	___ degrees
Parking brake test facing uphill	___ degrees

Additional information not required for disclosure in the product literature:

Wheel lock lever force	___ kg (___ lb)
------------------------	-----------------

See Figure 31.

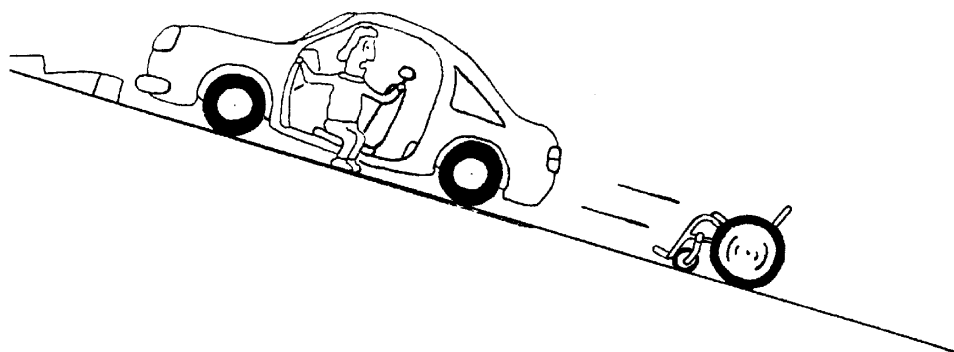

Figure 31 — Faulty wheel locks could leave you driving after your chair!

6.2.4.3 Interpretation of results — Wheel locks

The larger the angle disclosed, the greater the effectiveness of the wheel locks and the less chance the wheelchair will roll, slide or tip on an inclined surface with the wheel locks engaged. It is important to remember that wheel locks only prevent the wheels from turning; they do not prevent the chair from sliding. Remember, wheel locks are just “parking brakes”; they are not for stopping your chair while you are rolling.

The force required to lock and unlock the wheel locks may also be a concern. There is a test procedure for measuring this force, but manufacturers are not required to disclose the results of this test in the product literature. For users with limited arm strength or range of motion, extension handles can decrease the effort required to engage the locks.

Another item to consider is the location of the wheel locks. Low-, mid- or high-mount wheel locks are available. Because low-mount wheel locks are farther away from you, they are less likely to injure your thumbs or hands. Of course, they may also be more difficult to reach. High-mount wheel locks are easier to reach but can injure your thumbs or hands when you push on the tyres instead of the handrims to propel your chair. Pushing on the tyres is common to get better traction at times. Wheel locks also can get in the way during transfers. Swing-away wheel lock designs virtually eliminate the possibility of injury to your thumbs or hands.

6.3 Dimensions

6.3.1 General

Dimensions are the sizes of the wheelchair surfaces where your body will fit. This information, as disclosed in the test procedures, is very different from previous methods for measuring wheelchairs. Wheelchairs are now measured with a weighted test dummy sitting in the chair to simulate a rider, which more accurately represents the true dimensions of the wheelchair when it is occupied. The biggest problem with the dimensional information provided by manufacturers has been that the size of the wheelchair frame was measured using different methods, resulting in information that could not be compared from one manufacturer to another. If you have not already done so, you may want to go back and read Clause 5, "Incorporating personal body characteristics," for information on seating dimensions.

The following subclauses provide information on the dimensions of the wheelchair:

- overall dimensions, and
- seating dimensions.

6.3.2 Overall dimensions

6.3.2.1 How big is the wheelchair?

If you live in an apartment with a small bathroom, or if there are narrow doorways in your home or office, you will need to consider the overall size of the wheelchair when you make your selection. This test also discloses information that is important if you need to put your wheelchair in the boot (trunk) or backseat of your car. Your wheelchair should fit into your environment or at least not significantly hinder access to your home, office or car.

6.3.2.2 Determination of overall dimensions

A test procedure is given in ISO 7176-5:1986, *Wheelchairs — Part 5: Determination of overall dimensions, mass and turning space*.

A wheelchair is measured in the fully opened and folded positions for its overall length, width, and height. These dimensions represent the maximum size box required to contain the wheelchair.

Disclosure format (as reported by manufacturers)

Name of test	Test result
Overall length including leg support and footrest	___ mm (___ inches)
Overall length excluding leg support and footrest	___ mm (___ inches)
Overall width	___ mm (___ inches)
Minimum folded length	___ mm (___ inches)
Minimum folded width	___ mm (___ inches)
Minimum folded height	___ mm (___ inches)

For a list of additional information not required for disclosure in the technical product literature, see Annex A.

See Figure 32.

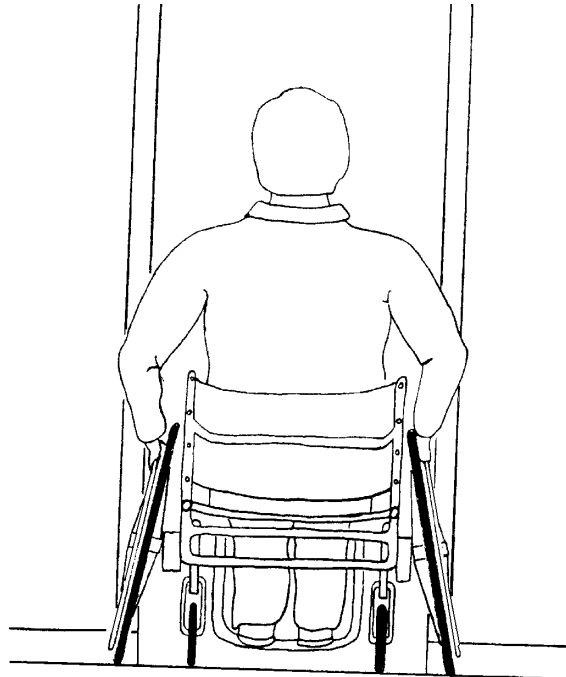

Figure 32 — Extra wheel camber can be a great performance feature, but not necessarily an access feature

6.3.2.3 Interpretation of results — Overall dimensions

This test discloses the dimensions of a wheelchair when it is folded and when it is open. Since all chairs are measured using the same method, you can compare wheelchairs made by different manufacturers. The overall dimensions give you the size of the wheelchair with no parts removed. This helps you determine whether or not the wheelchair will fit through doorways, around your home, on your van lift, and in your office. The overall length of an occupied wheelchair will be longer if your feet stick out over the end of the footrests, as they usually do. If you find yourself in a really tight spot, anti-tippers can be used as rear wheels by removing the main rear wheels of the chair. If the wheels of the anti-tippers can roll, they may enable you to pass through a narrow doorway or down the aisle of an aeroplane.

If the wheelbase of the wheelchair is adjustable by changing the position of the rear wheels or castors, a range of values will be disclosed. A range of values for overall length indicates that the horizontal position of the front and/or rear wheels is adjustable. A range of values for the overall width indicates that the main rear wheel camber is adjustable. Increasing the camber makes the wheelbase wider; consequently, passing through doorways may be more difficult. There is a trade-off between the overall dimensions and the stability of a wheelchair. While decreasing the wheelbase of the chair may make it easier for you to fit into your environment, it may also make the chair less stable.

Using the results of this test and the results of the manoeuvrability test, you will be able to select a chair that will not create additional architectural barriers. Your new wheelchair may even improve access to your environment.

Folded wheelchair dimensions are important to consider for transport and storage. These dimensions help you determine whether the wheelchair will fit in the boot (trunk), in the backseat of your car, or in other storage areas. You should pay particular attention to the folded dimensions and the weight of the wheelchair if you will be picking up your wheelchair and/or storing it in small places (see 6.1.1 under “Manual wheelchairs”).

Many wheelchairs can be disassembled into several parts to facilitate transport or storage of the chair. Sometimes, fitting a wheelchair into a car can seem like a puzzle. If you need to fit your wheelchair into a car with a small or irregularly shaped boot (trunk), knowing the dimensions of the largest component will be helpful. This information is not required for disclosure in the product literature, but can be obtained from the manufacturer upon request. If you travel abroad or are thinking about it, be aware that most public and private transportation vehicles (e.g. planes, trains) have small storage spaces.

6.3.3 Seating dimensions

6.3.3.1 Will the wheelchair fit me?

If you have ever sat in a poorly fitted wheelchair, you know why this information is critical. Not all wheelchairs are designed to fit every body shape, size and proportion. An improperly fitted wheelchair can result in discomfort, medical complications and decreased performance. To understand how to choose the best size for you, see Clause 5, "Incorporating personal body characteristics."

See Figure 33.

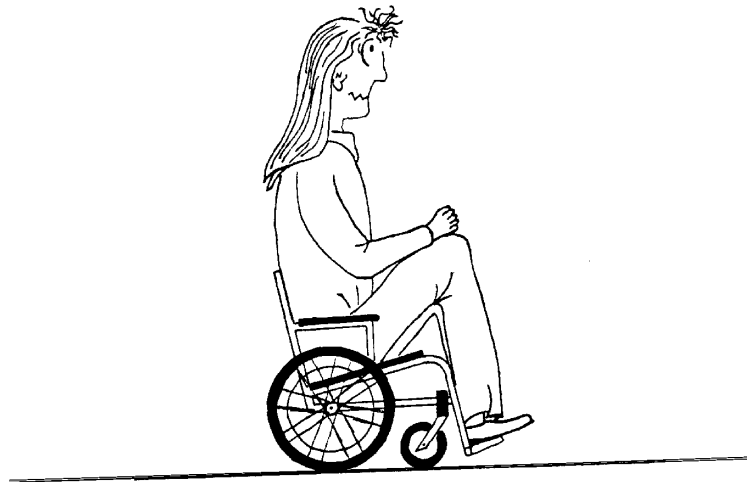

Figure 33 — Getting a wheelchair to fit properly takes a lot of patience and careful measurement during the assessment process

6.3.3.2 Determination of seating dimensions

A test procedure is given in ISO 7176-7:1998, *Wheelchairs — Part 7: Measurement of seating and wheel dimensions*.

Because the dimensions of a wheelchair seat may vary from an unloaded state to a loaded state, a reference loader gauge is placed in the wheelchair during the measurement process. For wheelchairs with adjustable features, each measurement is made with variations in adjustments such that the minimum and maximum measurements are obtained.

Disclosure format (as reported by manufacturers)

Name of test	Test result
Seat plane angle	___ degrees
Maximum seat width	___ mm (___ inches)
Seat depth	___ mm (___ inches)
Seat surface height at front edge (to floor)	___ mm (___ inches)
Backrest angle	___ degrees
Backrest height	___ mm (___ inches)

Headrest height above seat	___ mm (___ inches)
Footrest to seat distance	___ mm (___ inches)
Leg to seat surface angle	___ degrees
Armrest height	___ mm (___ inches)
Front of armrest to backrest	___ mm (___ inches)
Armrest length	___ mm (___ inches)
Distance between armrests	___ mm (___ inches)
Front location of armrest structure at 26,75 in	___ mm (___ inches))
Handrim diameter	___ mm (___ inches)
Propelling wheel diameter	___ mm (___ inches)
Horizontal location of wheel axle	___ mm (___ inches)

See Annex A for additional dimensional information that is not required for disclosure in the product literature.

6.3.3.3 Interpretation of results — Seating dimensions

If you know the seating dimensions that are appropriate for you, the results of this test will provide the information you need to determine which wheelchairs will fit. A range of values indicates that a particular dimension can be changed or adjusted.

Before you set your mind on a particular wheelchair based on its performance, examine the seating dimensions and their adjustability to ensure a proper fit. If you do not fit correctly in the chair, all the other features and benefits of the chair may be useless.

7 Powered wheelchairs

7.1 Performance

7.1.1 General

When you consider both scooters and full-sized chairs, there are hundreds of powered wheelchairs on the market today. As you begin the process of comparison shopping, you will want to know exactly what the chair is capable of doing. The ISO test procedures apply to both full-sized powered wheelchairs and three- and four-wheeled scooters. In this clause both types of chairs are referred to as powered chairs.

Is the wheelchair

- faster than a speeding bullet?
- more powerful than a locomotive?
- able to leap tall buildings in a single bound?

These and other performance features are revealed in the following test procedures:

- a) speed;
- b) obstacle-climbing ability;

- c) range;
- d) manoeuvrability;
- e) durability — fatigue strength;
- f) climatic test.

For performance tests a) to e) listed above, the manufacturer will disclose the results as specific values. There are no minimum performance values; therefore, no wheelchair will fail these tests. If a chair is only capable of going 1 mile/h and climbing a half-inch step, that is what is reported. It will be up to you to determine if the wheelchair's performance is compatible with your abilities, lifestyle and environment.

The last test (climate) is a pass/fail test. The wheelchair will either perform or not perform properly after being subjected to various climatic conditions.

More performance does not necessarily mean a better wheelchair; all performance specifications for powered wheelchairs should be viewed in relationship to your specific needs.

7.1.2 Speed

7.1.2.1 How fast can the chair go?

Are you a speed demon? If you want the fastest wheelchair on the market, this is the information you are looking for. You can use this information, like the results of automobile testing found in magazines, to compare the maximum speeds of different wheelchairs. If you commute to work or school via your wheelchair, the time it takes you to travel from point A to point B is probably important to you.

7.1.2.2 Determination of speed

A test procedure is given in ISO 7176-6:2001, *Wheelchairs — Part 6: Determination of maximum speed, acceleration and deceleration of electric wheelchairs*.

To determine maximum speed, the wheelchair is placed on a hard, flat, horizontal test surface. A test subject drives the wheelchair forward at full speed between two markers. The time to cover the distance between the markers is recorded for four runs. The maximum speed is calculated by dividing the distance between the markers by the average time of the four runs. The test is then repeated with the wheelchair driven backward at maximum speed.

Disclosure format (as reported by manufacturers)

Name of test	Test result
Maximum speed / forward	___ m/s or ___ km/h (___ miles/h)
Maximum speed / backward	___ m/s or ___ km/h (___ miles/h)

Additional information not required for disclosure in the product literature:

Maximum acceleration:

Maximum retardation (stopping):

See Figure 34.

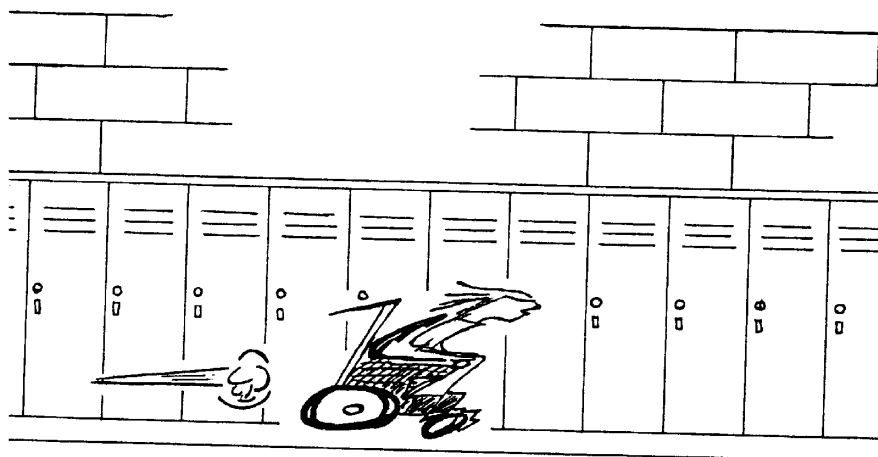

Figure 34 — Speed can be appropriate in the right environment

7.1.2.3 Interpretation of results — Speed

An important issue to consider when deciding what speed best meets your needs is the environment in which you will be operating your chair. Driving a wheelchair indoors usually means travelling short distances at lower speeds. If you will be riding your wheelchair mainly indoors, you will probably want to select a chair with a maximum speed of less than 5 miles/h. If you plan to use your chair outdoors, you will most likely be travelling longer distances at higher speeds. If you do not want to leave your able-bodied friends in the dust, refer to Table 8 to find out how fast the average person travels by foot.

Table 8 — Average speeds for various activities

Activity	Average speed		
	miles/h	m/s	km/h
Average walk	3,0	1,3	4,8
Brisk walk	4,5	2,0	7,2
Slow jog	6,0	2,7	9,7
Moderate run	8,0	3,6	12,9
Fast run	11,0	4,9	17,7

A second issue to consider is your physical ability to tolerate speed. Some people are unable to maintain sitting balance when moving quickly over rough terrain. The ability to maintain your balance also is an issue during acceleration (speeding up), retardation (slowing down) and turning.

Just because a wheelchair is fast does not mean it has enough power to climb an obstacle or go up a steep hill. If the maximum speed of the wheelchair is adjustable, the manufacturer will give a range of speeds. The maximum speed adjustment allows you (or in some cases, the dealer) to change the chair's maximum speed. Unfortunately, on some wheelchairs (those without programmable controllers), reducing the maximum speed may also reduce the power available for climbing over obstacles and up steep inclines.

Traditionally, powered wheelchairs have a high/low speed switch that is used to set the chair for outdoor or indoor mobility. However, many wheelchairs now have programmable controllers that can be permanently adjusted. There is some controversy about rider adjustment of dynamic controller characteristics. Manufacturers are concerned about liability and feel that if riders are allowed to adjust these features, they may hurt themselves. Regardless of whether adjustments are performed by the dealer or the rider, after they are made you should drive the wheelchair in a controlled environment to test its performance features.

You may want to choose a wheelchair that lets you adjust the speed or other functions easily for use in different environments. If your abilities are changing, you may want a chair that can be adjusted to meet your functional needs at any given time. If you won't be changing the adjustments frequently, or if you do not want other people (such as children) to fiddle with the adjustments, easy access to the controls may not be important.

7.1.3 Obstacle climbing

7.1.3.1 How high a step can the wheelchair climb?

It would be terribly frustrating if there was a 3-inch step at the entrance to your friend's apartment and your wheelchair could only negotiate a 2 ½-inch step. Although the majority of public places must comply with ADA Accessibility Guidelines, you may be forced to negotiate a kerb, for instance, when a car has blocked the ramp. Or perhaps you just want a high-performance wheelchair.

See Figure 35.

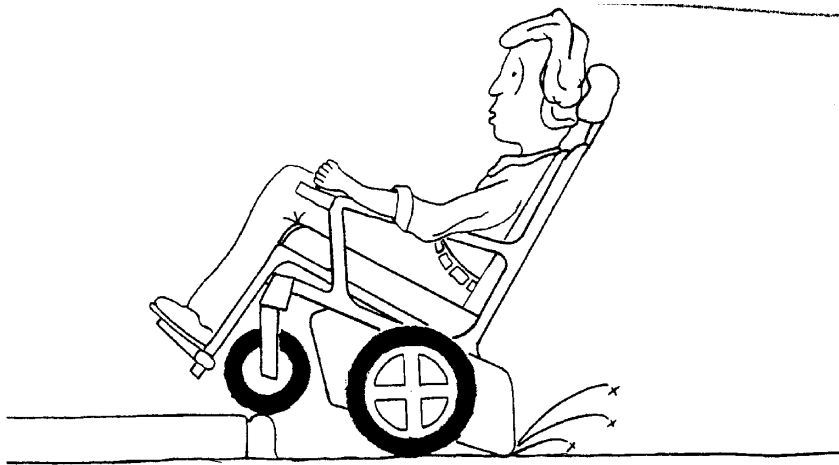

Figure 35 — Negotiating small kerbs and obstacles is a very important feature to most powered wheelchair users

7.1.3.2 Obstacle climbing test

A test procedure is given in ISO 7176-10:1988, *Wheelchairs — Part 10: Determination of obstacle-climbing ability of electric wheelchairs*.

A test dummy or a driver is positioned in the wheelchair. The wheelchair is driven, without a run-up, towards a rectangular obstacle such that it climbs completely on top of the obstacle. The height of the obstacle is increased until the wheelchair is unable to complete the obstacle climb. The test is then repeated with a run-up. The wheelchair is allowed to pick up speed by driving it a distance of 0,5 m (1,6 ft) before climbing the obstacle.

The maximum obstacle height that the wheelchair is able to climb is disclosed. The test results also indicate the approach angle to the obstacle and whether the wheelchair was travelling forwards or backwards, with or without a run-up.

Disclosure format (as reported by manufacturers)

Climbs a maximum height obstacle of ___ mm (___ inches), travelling (forwards/backwards) with (no run-up/0,5-m run-up) at an approach angle of 90° (unless a different angle is disclosed).

7.1.3.3 Interpretation of results — Obstacle climbing

Before you choose the wheelchair with the highest performance, consider your needs and the environment in which you will be operating your chair. If you plan to use your chair mainly indoors, the ability to climb large obstacles may not be important. If you will use the wheelchair outdoors, you may want a chair with better obstacle-climbing ability.

The obstacle-climbing ability of the wheelchair is greatly affected by the size and type of the wheels. Larger diameter castors will climb over larger obstacles; small castors will tend to get stuck or will require more power to climb over obstacles. Although solid castors provide less rolling resistance on hard, smooth, level surfaces, they are poor obstacle climbers. Pneumatic and semi-pneumatic castors will roll over obstacles and outdoor surfaces much more easily. Generally, wheelchair users who spend a lot of time outdoors prefer larger pneumatic or semi-pneumatic castors; those who use the chair primarily indoors on hard surfaces usually prefer smaller, harder castors. Scooters with larger wheels will generally climb larger obstacles. Scooters with rear-wheel drive tend to have better obstacle-climbing ability as well.

Anti-tippers may restrict mobility outdoors, particularly going up and down kerbs and making other height transitions. Anti-tippers limit the obstacle-climbing ability of the wheelchair because they prevent the wheelchair from tipping backwards past a certain point. When you are travelling down a transition in height, such as a dropped kerb, the anti-tippers can get caught. Removing anti-tippers could increase your ability to negotiate obstacles, but this could also cause a potential safety hazard.

Ground clearance (the distance from the ground surface to the lowest part of the wheelchair) also affects the obstacle-climbing ability of the wheelchair. While the front castors of a wheelchair may be able to climb over an obstacle, such as a railroad track, another part of the chair may get caught. International Standards on wheelchairs do not currently include a test for ground clearance.

In conjunction with the obstacle-climbing ability of the wheelchair, you should consider the static and dynamic stability of the chair to ensure safe operation.

7.1.4 Range

7.1.4.1 How far can the wheelchair go?

Running out of battery power at night, in the middle of a strange part of town, could be a frightening or a character-building experience. In a snowstorm or on an extremely cold night, it could be fatal. If you must travel long distances across a college campus or in a city, you will want to know just how far the wheelchair will travel before the batteries need to be recharged. See Figure 36.

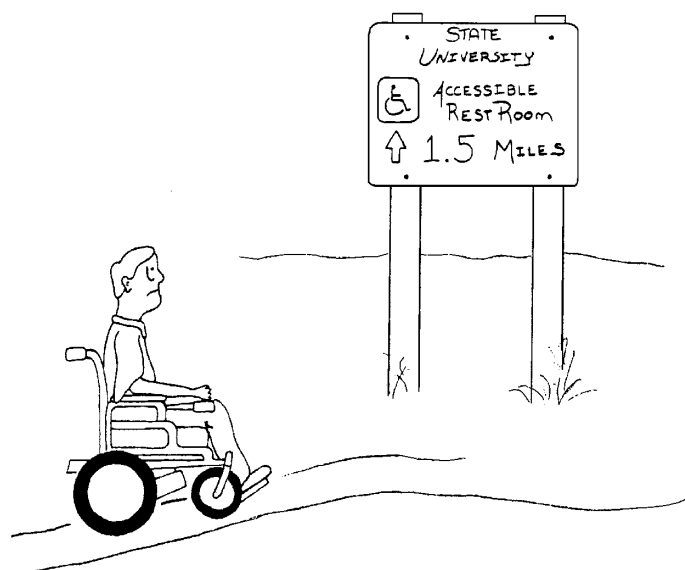

Figure 36 — Running out of power can be a real problem!

7.1.4.2 Determination of range

A test procedure is given in ISO 7176-4:1997, *Wheelchairs — Part 4: Energy consumption of electric wheelchairs and scooters for determination of theoretical distance range*.

The wheelchair is placed on a standardized test surface with a test rider in the chair. The test rider drives the wheelchair through a specified test course that simulates an indoor or outdoor environment. The indoor test circuit involves driving forwards and backwards, starting and stopping. In the outdoor test, the wheelchair is driven through a test circuit involving accelerating from a stop to maximum speed, driving a specified distance, and then stopping.

By measuring the energy consumption of the wheelchair using a watt-hour meter, the total range of the wheelchair is calculated, given the nominal capacity of the batteries on the wheelchair.

Disclosure format (as reported by manufacturers)

Name of test	Test result
Range/Indoor use	___ km (___ miles)
Range/Outdoor use	___ km (___ miles)

7.1.4.3 Interpretation of results — Range

This test is similar to the Environmental Protection Agency’s (EPA) miles-per-gallon rating for city and highway automobile driving. This information provides a basis for comparing wheelchairs, but does not guarantee that you will get the same results in your own wheelchair. The distance you will be able to travel before the batteries need to be recharged depends greatly on the environment and your riding habits. If you live in San Francisco and tend to start and stop like a race car driver, you can expect the range of the wheelchair to be significantly less than if you use it in a large warehouse during work. The test procedures set up an average use situation, but you will need to compare your lifestyle with that situation.

7.1.4.4 Batteries

The type and age of the batteries on your wheelchair will affect how far it will be able to go between charges. There are two main types of wheelchair batteries: lead acid and gel cell. The size of the battery is indicated by a standard group size number, such as U1, 22NF, 24, or 27. Generally, the bigger the battery the more energy it can store, although this is not always the case. Table 9 shows the dimensions of batteries commonly used on wheelchairs.

Table 9 — Dimensions of batteries

Values in inches

Group size	Length	Width	Height
U1	7 3/4	5 3/16	7 5/16
22NF	9 7/16	5 1/2	8 15/16
24	10 1/4	6 13/16	8 7/8
27	12 1/16	6 13/16	8 7/8

Among batteries of the same group size, a gel cell generally has slightly less energy than a lead acid, and consequently the wheelchair will have less range. Many airlines restrict the transport of lead acid batteries; therefore, if you anticipate travelling by plane, you should use gel cell batteries. If you have to take your wheelchair apart for transport in a car, you also might want to consider the use of gel cells. In fact, gel cell batteries are safer in any situation in which your batteries might tip over, as they are much less likely to leak.

If you know the correct group size, you can buy the batteries directly from a battery supplier rather than a wheelchair dealership. However, installation will not be included if you purchase batteries from a battery supplier.

7.1.5 Manoeuvrability

7.1.5.1 How much space does the wheelchair need to turn around?

Most likely, you have created a home or office environment that allows you as much access as possible in your current wheelchair. You want to be sure any new chair you select does not create new architectural barriers because its turning space is larger than that of your current chair. On the other hand, you may want to improve your access so you can manoeuvre more easily in hotel rooms, tight office spaces, narrow hallways, bathrooms, or those ridiculously small public toilet stalls. There is a tremendous difference in the manoeuvrability of three-wheel scooters, traditional powered chairs and front-wheel-drive powered chairs.

See Figure 37.

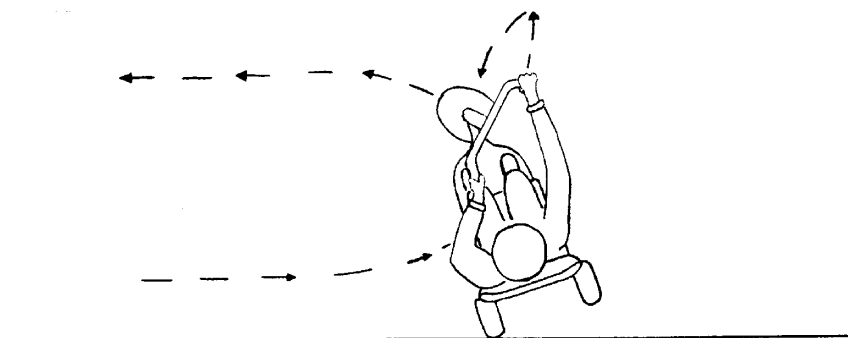

Figure 37 — Being able to turn around without destroying the walls is important in your home or office!

7.1.5.2 Determination of manoeuvrability

A test procedure is given in ISO 7176-5:1986, *Wheelchairs — Part 5: Determination of overall dimensions, mass and turning space*.

An adjustable corridor is created and a three-point turn manoeuvre is performed as illustrated in Figure 37. The corridor is narrowed until the wheelchair is unable to perform the manoeuvre. The minimum corridor width is disclosed.

Disclosure format (as reported by manufacturers)

Name of test	Test result
Minimum turnaround width	___ mm (___ inches)

Additional information not required for disclosure in the product literature:

Minimum turning radius	___ mm (___ inches)
------------------------	---------------------

7.1.5.3 Interpretation of results — Manoeuvrability

The results of this test are essential if you live or work in an environment with tight spaces. If there is a particularly narrow hall or space at home, work or school, measure its width and search for chairs that can make a three-point turn in spaces that size or smaller. Remember that many wheelchairs can be equipped with footrest assemblies that can be removed. Although having to remove the footrests while using the wheelchair is an inconvenience, it can increase the chair's ability to turn around in a tight spot. The size of the front or rear castors can also affect the wheelchair's manoeuvrability. Large castors may interfere with your footrests when they swivel, making it more difficult to manoeuvre in small areas.

Once you have limited your choice to a few chairs, you may want to check the turnaround space for each of the chairs to make sure they will be able to get you through or into and out of any tight spots in your home.

7.1.6 Durability — Fatigue strength

7.1.6.1 How long will the wheelchair last?

A wheelchair is a major purchase; the last thing you want is a chair that falls apart after a month of taking it over bumps, up and down kerbs, and through all the environments you go through every day. How long will a wheelchair last? The durability of the chair is important, whether you are a very active user or not. If a wheelchair component breaks, you could be hurt or stranded somewhere. Fatigue tests are intended to determine the durability of the wheelchair and its components by subjecting them to a large number of low-level stresses, similar to the forces a chair is subjected to in daily use.

7.1.6.2 Determination of durability and fatigue strength

A test procedure is given in ISO 7176-8:1998, *Wheelchairs — Part 8: Requirements and test methods for static, impact and fatigue strengths*.

The wheelchair, loaded with the test dummy, is positioned on the double-drum fatigue test machine that consists of two cylindrical drums. Mounted on the drums are slats which contact the front and rear wheels at different times, as one drum rotates slightly faster than the other. The chair drives the test machine for a pre-determined number of cycles.

In the kerb drop test, the loaded wheelchair is dropped in a free-fall manner from a height of approximately 2 inches. One kerb drop fatigue test is performed for every 30 cycles on the double-drum fatigue test machine. The manufacturer is asked to disclose the number of cycles that the wheelchair has performed without failure on the double-drum and kerb drop test machines.

Disclosure format (as reported by manufacturers)

Name of test	Test result
Double-drum test	___ cycles
Kerb drop test	___ cycles

See Figure 38.

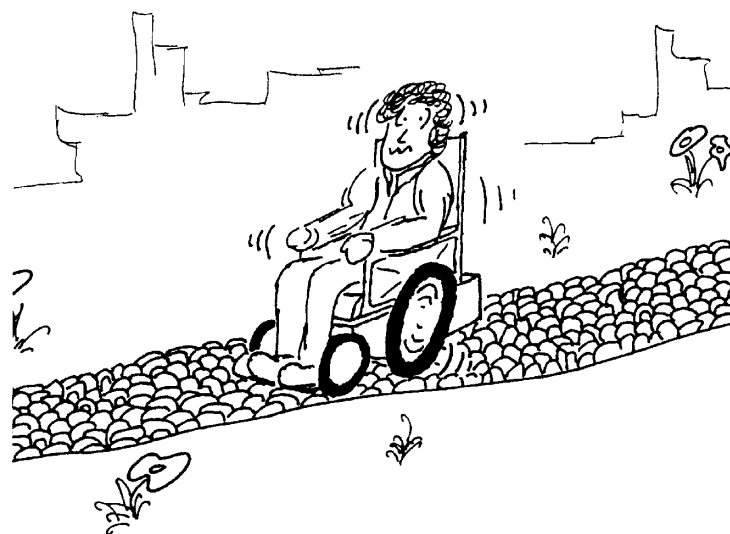

Figure 38 — Hhhoowww dddurrrable is thththe chchchair?

7.1.6.3 Interpretation of results — Durability and fatigue strength

If the manufacturer discloses that the chair has been tested with a large number of double-drum and kerb drop cycles, it means that the chair is more durable than one that only passed a smaller number of test cycles. However, if the manufacturer discloses that the chair has been tested to a smaller number of double-drum and kerb drop cycles, it may only mean that they stopped testing after that many cycles. Unfortunately, the test procedures do not require manufacturers to test their wheelchairs until they fail. The manufacturers are only required to disclose how many cycles the wheelchair completed without failure.

During fatigue testing, the entire wheelchair (frame, seat upholstery, wheels and all other components) is subjected to a large number of stresses. The composition and construction of each of these components affects how many cycles the wheelchair can perform without failure.

7.1.6.4 Frame material

While many of the components can be replaced for a small fraction of the cost of the wheelchair, the frame cannot. Powered wheelchair frames are generally available in steel or aluminium. A steel frame is not necessarily more durable than an aluminium frame. Although each material has a specific amount of strength per unit mass, the designs vary so much that you cannot determine the durability of the product solely by the material used. The frame tubing thickness, tubing shape, welding technique, and how the components are joined, are just a few of the factors that affect the fatigue strength of the chair.

While the type of frame material may not indicate how long the chair will last, it does provide some other helpful information. See Table 10.

Table 10 — Characteristics of frame materials

Frame material	Advantages	Disadvantages
Steel	<ul style="list-style-type: none"> Easily repaired and welded in places where high-technology welding equipment is not available Moderate strength-to-mass ratio 	<ul style="list-style-type: none"> Relatively heavy
Aluminium	<ul style="list-style-type: none"> High strength-to-mass ratio 	<ul style="list-style-type: none"> More expensive than mild steel

7.1.6.5 Frame finish

The way the frame of the chair is chemically prepared, primed and painted will affect the durability of the finish. Steel and aluminium can be finished with various standard processes. One of the best processes is powder coating, which minimizes paint waste and results in a durable finish.

7.1.6.6 Castors

Both the size and the type of castor affect the durability of the wheelchair. During the double-drum test, the slats on the cylindrical drum constantly hit the castors, and the forces generated are transferred to the rest of the chair. This is similar to what occurs when you ride over obstacles or uneven terrain. Larger pneumatic castors absorb these forces better than smaller castors and will result in less wear and tear on other wheelchair components.

7.1.7 Climate tests

7.1.7.1 How will temperature and moisture affect the operation of the chair?

Extremes in temperature and frequent temperature changes may affect your wheelchair. If you live in Arizona you may want to know that your controller won't fail while you are climbing a hill in the hot sun. When you leave a warm building and go outside into the cold, the electronics on your wheelchair are significantly stressed. For this reason you will find the results of this test helpful in your wheelchair selection process. Even if you don't live where there are extreme changes in temperature, you may find yourself caught in a rainstorm someday, and you will need to know that your wheelchair will perform properly after getting wet. See Figure 39.

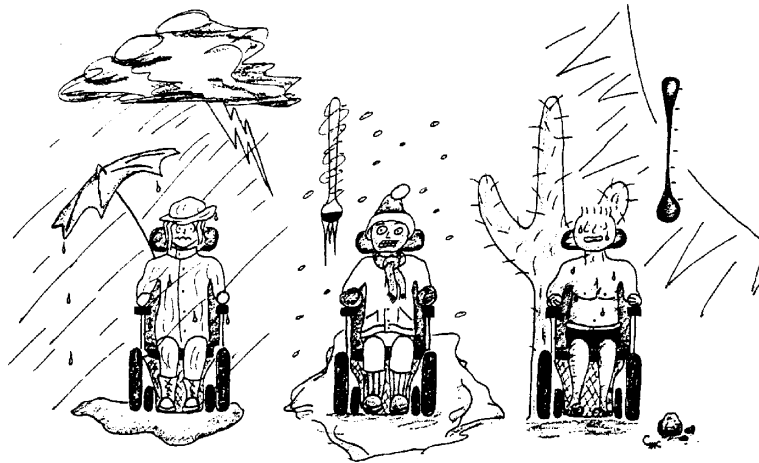

Figure 39 — Try to foresee different situations in which you might end up using your powered chair

7.1.7.2 Tests in various climates

A test procedure is given in ISO 7176-9:2001, *Wheelchairs — Part 9: Climatic tests for electric wheelchairs*.

The wheelchair is subjected to a standardized shower test. If the wheelchair does not function properly after this test, it fails the effects-of-rain test.

The chair is exposed to temperatures of $-25\text{ }^{\circ}\text{C}$ ($-13\text{ }^{\circ}\text{F}$) and $+50\text{ }^{\circ}\text{C}$ ($122\text{ }^{\circ}\text{F}$) for 3 h and then driven immediately, without allowing it to return to room temperature. To test the affects of shipping and storage, the wheelchair is exposed to a temperature of $40\text{ }^{\circ}\text{C}$ ($-40\text{ }^{\circ}\text{F}$) for 3 h and then to a temperature of $+65\text{ }^{\circ}\text{C}$ ($149\text{ }^{\circ}\text{F}$) for 3 h. The wheelchair is returned to room temperature for at least 24 h and then driven. If the wheelchair does not function properly after these two tests, it fails the effects-of-temperature-change test.

Disclosure format (as reported by manufacturers)

Name of test	Test result
Effects of rain	pass/fail
Effects of temperature change (includes operation and storage temperature)	pass/fail

7.1.7.3 Interpretation of results — Climate tests

If a wheelchair fails the effects-of-rain or effects-of-temperature-change test, it did not operate properly after being subjected to rain, extreme temperature changes during regular operation, or extreme storage temperature conditions. If you will be subjecting your chair to changes in temperature or exposing it to moisture or rain, make sure the wheelchair you are considering passed this test. If a wheelchair failed the rain portion of the climate test and you live in Seattle, you may want to consider a different wheelchair.

7.2 Safety

7.2.1 General

Most of the time you have full control of your chair. At times, however, either when you need assistance from someone else or because of careless or reckless riding, the chair may be exposed to damaging forces or unsafe conditions. To ensure against an unsafe wheelchair design, the following tests subject the chair to forces or conditions that could result in a hazardous situation. The test results are either pass or fail. Test outcomes that place the rider at risk are recorded as a failure.

The safety tests for powered wheelchairs include:

- a) static and dynamic stability;
- b) stopping distance;
- c) disengage force and non-powered push;
- d) safety guards;
- e) electrical systems;
- f) static and impact strength;
- g) flammability;
- h) battery chargers.

The strength of a powered wheelchair includes static and impact strength. Static tests determine the strength of the wheelchair and its components under high-stress loads that may occur only occasionally. Impact tests determine the strength of the wheelchair and specific components under conditions of impact loading, such as striking an object or dropping all or part of the wheelchair.

7.2.2 Static and dynamic stability

7.2.2.1 How stable is the wheelchair?

Your powered wheelchair will not always be driven on a level surface. There will be times when you need to go up a ramp, and you want to be sure that the wheelchair will not tip over backwards. You will also want to be able to stop your wheelchair when you are going down a ramp. Suppose there is a ramp leading to the front door of your house. If you attempt to drive your wheelchair up the ramp, you don't want to find yourself performing acrobatics on your doorstep! See Figure 40.

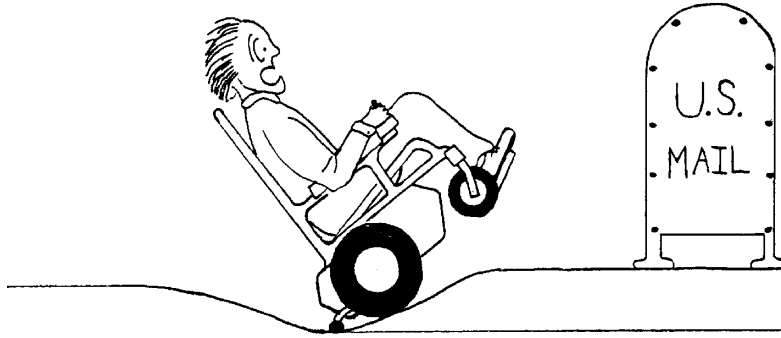

Figure 40 — Static and dynamic stability test results will give you an indication of how stable the wheelchair will be in different environments

7.2.2.2 Determination of static and dynamic stability

One test procedure is given in ISO 7176-1:1999, *Wheelchairs — Part 1: Determination of static stability*.

In the static stability test, the wheelchair is placed on a standardized test surface with a test dummy positioned in the chair. The surface is tilted with the wheelchair facing uphill, downhill and sideways. The angle at which the wheels of the wheelchair lift off the test surface is recorded in degrees.

Other test procedures are given in ISO 7176-2:2001, *Wheelchairs — Part 2: Determination of dynamic stability of electric wheelchairs*.

In the starting uphill test, the wheelchair is placed on a standardized test surface with a test dummy or driver positioned in the chair. The surface is tilted with the wheelchair facing uphill. The minimum slope at which the wheelchair begins to tip back past its balance point when full forward power is applied is recorded in degrees.

In the braking downhill test, the wheelchair is run at maximum speed down a slope of 5°. The controls are then operated to produce an immediate stop. The manufacturer notes if one or more wheels lift from the test plane, if the wheelchair tips forward beyond its balance point, or if the wheelchair slides on the surface.

Disclosure format (as reported by manufacturers)

Static stability test

Test result

Facing downhill/brakes on, tips at ___ degrees of slope

Facing uphill/brakes on, tips at ___ degrees of slope

Facing sideways/brakes on, tips at ___ degrees of slope

Other critical direction/brakes on, tips at ___ degrees of slope

Dynamic stability test

Test result

Starting uphill/tipping backwards ___ degrees

Braking downhill on 5° slope: one or more wheels lift/wheelchair tips/wheelchair slides or does not slide

Additional information on the dynamic stability of the wheelchair not required for disclosure in the product literature includes:

Stability when turned: one or more wheels lift/wheelchair tips/wheelchair slides or does not slide

7.2.2.3 Interpretation of results — Static and dynamic stability

The smaller the uphill tip angle, the less stable the wheelchair is in the backwards direction. A smaller downhill tip angle means that the chair is less stable in the forward direction. A chair with a smaller sideways tip angle is less stable to the side.

Three-wheeled scooters are generally less stable to the side than four-wheeled scooters and full-sized powered chairs. Because they have three wheels, scooters are less stable when positioned at an angle, unlike most other chairs.

With regard to starting forwards on an uphill slope, a larger tip angle means that the wheelchair is more stable and less likely to tip over backwards. The angle disclosed is the maximum slope on which full power can be applied without tipping over backwards past the balance point. If a ramp has been built in compliance with ADA Accessibility Guidelines, the maximum slope will be 1:12 (4,8°). Therefore, a wheelchair with a disclosed test result of greater than 5° will not tip backwards under normal circumstances when you climb a public ramp.

Anti-tippers affect the stability of the chair going uphill. Although they prevent the wheelchair from tipping to the rear, many people do not like using them because they restrict the chair's ability to climb over obstacles. In addition, it is almost impossible for the wheelchair user to adjust anti-tippers from the down/engaged position to the up position or vice versa while seated in the wheelchair. Whether or not you use anti-tippers, it may be prudent to practice new manoeuvres with an attendant as you learn how to safely negotiate new environments.

A wheelchair that can stop safely while travelling down a slope without tipping or sliding is obviously more desirable than one that cannot. Even if you don't have a ramp at your house or apartment, if you spend any time in public places, you will encounter sloped surfaces and will want a chair that can start and stop safely on ramps.

If the speed, acceleration and retardation of the wheelchair are adjustable, a range of stability results will be disclosed by the manufacturer. These adjustments allow you or the dealer to change how fast the chair can go, how quickly it reaches top speed, and how quickly it stops. After you make such adjustments, practice using the wheelchair in a controlled environment in which you can test all of its performance features to determine the effects of the adjustments.

You may want a wheelchair that lets you adjust the speed or other functions easily for use in different indoor and outdoor environments. If your abilities are changing, you may want a chair that can be adjusted to meet your functional needs at any given time. On the other hand, if you won't be changing the adjustments frequently, or if you do not want other people (such as children) to fiddle with the adjustments, easy access to the controls may not be important or even desired.

7.2.3 Stopping distance

7.2.3.1 How quickly does the wheelchair stop?

If your grandmother steps out in front of you as you're zooming down the hallway at top speed, will you be able to stop in time? There will be times when you will need to stop quickly to avoid hitting someone or something; therefore, you should know the capabilities of the wheelchair, as well as your own functional abilities. If you have poor upper body balance, you will probably want to avoid chairs that stop too quickly. If you lose your balance and your hand slips off the controller, you may also want to know how far the chair will travel before it comes to a complete stop. For example, will the wheelchair stop before reaching the end of the sidewalk, or will it continue off the edge? See Figure 41.

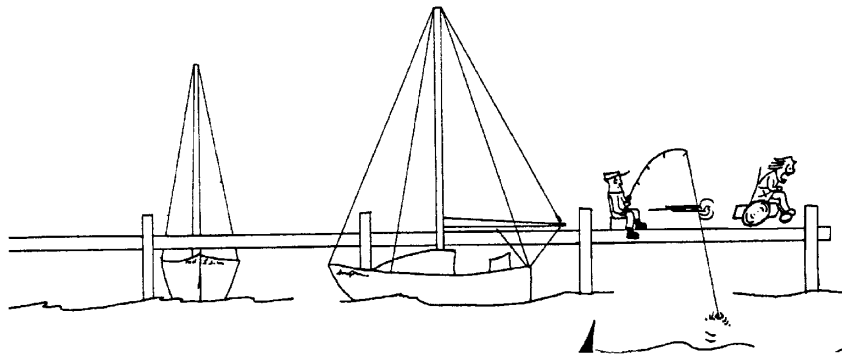

Figure 41 — Having a controller with responsive stopping characteristics is a good idea in many environments!

7.2.3.2 Determination of stopping distance

A test procedure is given in ISO 7176-3:2003, *Wheelchairs — Part 3: Determination of effectiveness of brakes*.

In the running brake test, the wheelchair is driven on a standardized, horizontal test surface with a driver in the chair. After reaching maximum speed, the wheelchair driver uses the controller to execute maximum braking until the wheelchair is brought to a stop. The maximum speed and the distance required for the wheelchair to stop are recorded. The running brake test is then repeated on a test surface with a slope of 5°.

In the automatic braking test, the wheelchair is driven forward down a test surface with a slope of 5° at its maximum speed and then the control mechanism is released. The maximum speed and the distance required for the wheelchair to stop are recorded.

Disclosure format (as reported by manufacturers)

Name of test	Test result
Running brake/travelling forward on horizontal surface	___ m (___ ft)
Running brake/travelling forward down 5° slope	___ m (___ ft)
Automatic braking/travelling forward down 5° slope	___ m (___ ft)

Additional information not required for disclosure in the product literature:

- Running brake test/travelling backward on a horizontal plane
- Effect of raised temperature, induced by continuous use, on the braking systems of powered wheelchairs
- Automatic braking/travelling forward on a horizontal plane

7.2.3.3 Interpretation of results — Stopping distance

If you compare two chairs with the same maximum speed, the chair with the shorter braking distance has a higher rate of retardation (stopping). This wheelchair will stop in a shorter time and distance and you will need better balance to maintain an upright posture. If you have poor balance, a wheelchair that stops slowly might be better for you than one with a very rapid response.

If the rate of retardation of the wheelchair is adjustable, a range of stopping distances is disclosed. The retardation adjustment allows you or the dealer to change how quickly the chair comes to a stop. If your abilities are changing, you may want a chair that can be adjusted to meet your functional needs at any given

time. A wheelchair with adjustable retardation will allow you to set the rate of retardation as fast as your body can handle without losing your balance.

The stopping distance will be much greater for a wheelchair without dynamic braking travelling down a sloped surface. If a wheelchair does not have dynamic braking, the chair may pick up speed as it travels downhill, creating a potentially hazardous situation.

7.2.4 Disengage force and non-powered push

7.2.4.1 How hard is it to push the wheelchair without power?

If you ever find yourself stranded as a result of controller or battery malfunction, someone will have to disengage the wheelchair drive system and push you. In a hazardous environment, you might prefer to have someone push you rather than driving the wheelchair. The force required to disengage the drive system and push the non-powered wheelchair should not require the strength of a body builder. See Figure 42.

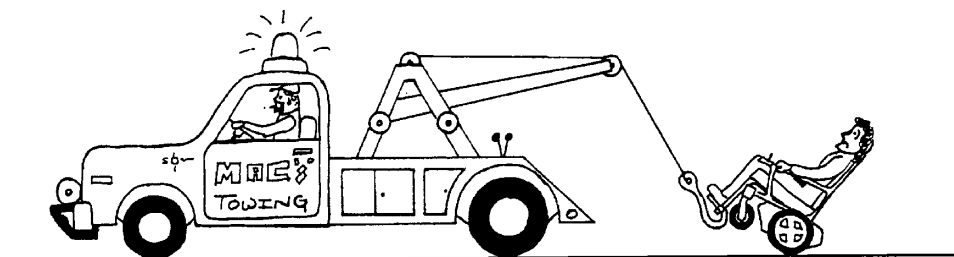

Figure 42 — If it takes a lot of force to move your wheelchair when it breaks down, you might need professional assistance

7.2.4.2 Determination of disengage force and non-powered push

A test procedure is given in ISO 7176-14:1997, *Wheelchairs — Part 14: Power and control systems for electric wheelchairs — Requirements and test methods*.

A force gauge is used to measure the force required to disengage the drive system. The force required to move the wheelchair loaded with a test dummy is also measured. If the force necessary to disengage the drive system exceeds 75 N (equivalent to 16,9 lbs) or the force necessary to move the loaded wheelchair exceeds 100 N (equivalent to 22,5 lbs), the wheelchair fails the test.

Disclosure format (as reported by manufacturers)

Name of test	Test result
Disengagement of drive system	pass/fail
Non-powered push force	pass/fail

7.2.4.3 Interpretation of results — Disengage force and non-powered push

If a wheelchair passes this test, it requires less than 75 N (equivalent to 16,9 lbs) of force to disengage the drive system and less than 100 N (equivalent to 22,5 lbs) to manually push the wheelchair. Unless you have a body builder nearby, you will probably want to limit your selection of wheelchairs to those that pass this test.

7.2.5 Safety guards

7.2.5.1 Are there appropriate safety guards on the wheelchair?

If you have children or you spend time with someone else's children, you know that they are constantly touching things they should not touch. As you sit in your wheelchair, you may not be able to watch everything that is going on around you. Without proper safety guards, the many moving parts on a powered wheelchair can create a dangerous situation for children. You, too, need to be assured that your clothing or fingers will not be eaten up by the wheelchair's drive system if your arm falls off the armrest.

7.2.5.2 Safety guard test

A test procedure is given in ISO 7176-14:1997, *Wheelchairs — Part 14: Power and control systems for electric wheelchairs — Requirements and test methods*.

A jointed and unjointed test finger is inserted into all openings to determine if contact can be made with moving parts. This test is applied to all openings where an occupant or someone out of the chair may contact a moving part, excluding the wheels, during normal operation.

If the test finger touches any of the moving parts of the propulsion system (except the wheels), the wheelchair fails the safety guard test.

Disclosure format (as reported by manufacturers)

Name of test	Test result
Safety guard requirements	pass/fail

See Figure 43.

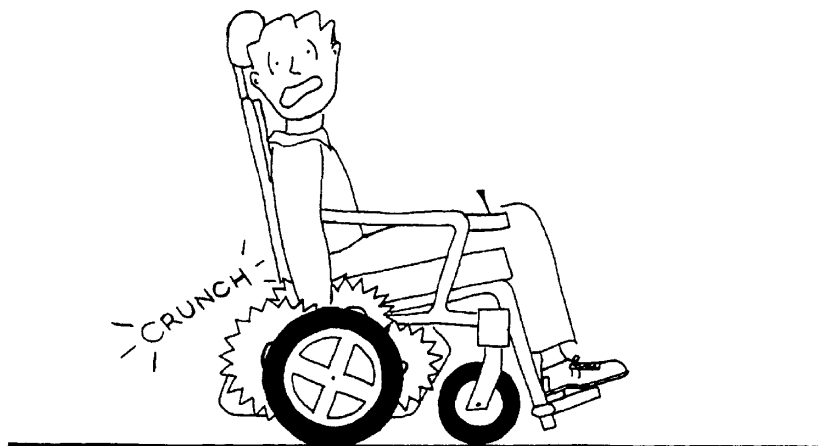

Figure 43 — And you thought slamming your fingers in a door hurt!

7.2.5.3 Interpretation of results — Safety guards

If the wheelchair fails this test, one or more moving parts on the chair are not guarded, or the guard does not provide adequate protection. If you operate your wheelchair around children or if your arm might slip from the armrest, you will want to make sure the chair passes this test. If you have your heart set on a wheelchair that fails this test, you will need to take extra care when you operate it around others who might touch the moving parts or when you wear clothing that could become entangled in the moving parts of the chair.

7.2.6 Electrical systems

7.2.6.1 Is the wheelchair electrically safe?

These tests target the complete electrical system on your wheelchair, including the wiring, connectors and controller. The powered wheelchair is a complex electromechanical system. You, the user of this system, need to feel confident that you will not be electrocuted, or that if you lose power the chair will stop before you drive into an obstacle. If you have questions or concerns regarding the connections, wiring or control of the wheelchair, the following tests will provide the needed information.

7.2.6.2 Electrical systems test

A test procedure is given in ISO 7176-14:1997, *Wheelchairs — Part 14: Power and control systems for electric wheelchairs — Requirements and test methods*.

A comprehensive set of test procedures is performed on the wheelchair. See Table 11. All of these tests are pass/fail.

Table 11 — Tests on electrical systems

Synopsis of test procedure	Result
The wheelchair must have a battery connection diagram.	pass/fail
Wiring connected to the positive output terminal of the battery shall be red or brown.	pass/fail
The frame of the wheelchair shall not be electrically grounded.	pass/fail
It shall not be possible to touch electrically live leads or terminals when changing fuses.	pass/fail
It shall not be possible to connect wiring in an incorrect manner.	pass/fail
Connectors shall not easily pull apart.	pass/fail
Wiring shall not protrude from the wheelchair.	pass/fail
It shall not be possible to touch noninsulated electrical parts.	pass/fail
Primary circuit protection shall be provided next to the battery pack.	pass/fail
It shall not be possible to drive the wheelchair when charging the batteries.	pass/fail
If the connections to the battery are reversed there should be no damage to the controller.	pass/fail
The control system shall not fail if the battery voltage rises by 25 %.	pass/fail
A command signal processing failure shall not result in uncontrolled movement of the wheelchair.	pass/fail
Failure of any output device shall not result in uncontrolled movement of the wheelchair.	pass/fail
When the wheelchair is stalled, circuit protection shall prevent damage to the wheelchair for a minimum of five minutes with a maximum speed command signal applied.	pass/fail
The temperature of all external surfaces accessible to the wheelchair user shall not exceed 50 °C (122 °F).	pass/fail
When the power supply is interrupted, the wheelchair shall stop on its own accord or as soon as it is steered in another direction or put in the stop position.	pass/fail

Disclosure format (as reported by manufacturers)

Name of test	Test result
Overall electrical system requirements	pass/fail

7.2.6.3 Interpretation of results — Electrical systems

If the manufacturer reports that the wheelchair passes the electrical system requirements, the wheelchair meets the requirements of all the above test procedures.

7.2.7 Determination of static and impact strength

7.2.7.1 How strong is the wheelchair?

Every day you subject your wheelchair to different stresses, and you want to know which wheelchairs will be able to withstand these stresses. See Figure 44. Not everyone is a perfect wheelchair driver. There will be times when you run into a doorway frame or other barriers with the castors, footrests, or main wheels. You may find yourself in a situation in which you need to be lifted up stairs and those lifting may grab the armrests and footrests of your wheelchair. To be safe, armrests and footrests should either pull right out or they should support the weight of you and your chair. Armrests must also be able to support your weight when you do push-ups.

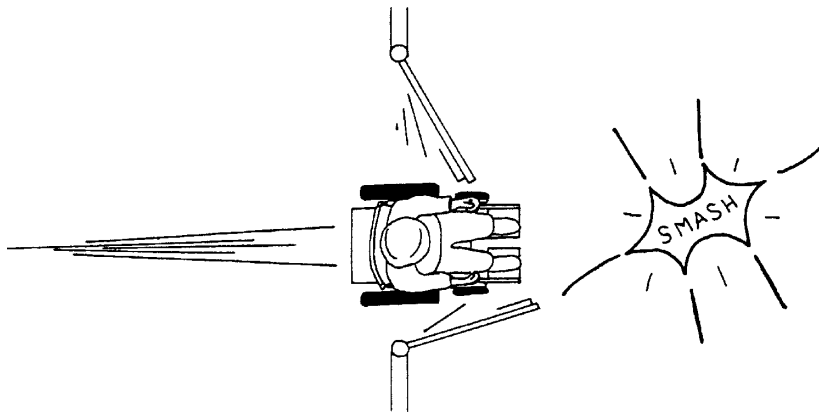

Figure 44 — The impact strength of your footrests is an important issue for simple everyday manoeuvres such as opening doors

7.2.7.2 Determination of static and impact strength

A test procedure is given in ISO 7176-8:1998, *Wheelchairs — Part 8: Requirements and test methods for static, impact and fatigue strengths*.

Static tests are intended to determine the strength of the wheelchair and its components under the high-stress loads that may occur only occasionally. Using a standardized loading pad or strap, a large force is applied once to the relevant part of the wheelchair. If a structural failure, deformation or maladjustment of any part of the wheelchair occurs, it does not pass the test.

Impact tests are intended to determine the strength of the wheelchair and specific components under conditions of impact loading, such as a person dropping onto the seat of the wheelchair or striking a kerb. A weighted ball is dropped once from a given height. If the impact results in a structural failure or deformation of part of the wheelchair that adversely affects its function, the wheelchair does not pass the test.

A pass or fail result indicates whether or not the wheelchair was functional after a known force was applied. The manufacturer may choose to test the wheelchair at higher forces and may or may not disclose them except for the armrest drop test and the loaded drop test, in which the maximum drop height that does not produce a failure is disclosed.

Disclosure format (as reported by manufacturers)

Name of test	Test result
Static strength tests	pass/fail
Impact strength tests	pass/fail

7.2.7.3 Interpretation of results — Static and impact strength tests

The wheelchair passes the static loads if the test results are as given in Table 12.

Table 12 — Results of static load test

Static load test	Requirement for pass	Disclosure format
Armrest downward	<ul style="list-style-type: none"> The armrest can still be removed and adjusted after a push-up. 	pass/fail
Footrest downward	<ul style="list-style-type: none"> The footrest returns to its original condition and can still be flipped up, swung away, or removed and reinstalled after a person extends or does a weight shift. 	pass/fail
Tipping levers downward	<ul style="list-style-type: none"> The tipping lever will not be deformed when a person steps on the lever to tilt the wheelchair backward. 	pass/fail
Hand grip	<ul style="list-style-type: none"> The handgrips will not slip off when a person pulls you and your wheelchair up or down steps. 	pass/fail
Armrest upward	<ul style="list-style-type: none"> If the wheelchair is lifted by the armrests, the armrests will either lift out of the socket before the chair is lifted off the ground or the armrests will be able to support the weight of the wheelchair and you, allowing you to be lifted up or down safely. 	pass/fail
Footrest supports upward	<ul style="list-style-type: none"> If the wheelchair is lifted by the footrests, the footrests will either lift out of the socket before the chair is lifted off the ground or the footrests will support the weight of the wheelchair and you, allowing you to be lifted up or down safely. 	pass/fail
Push handle(s) upward	<ul style="list-style-type: none"> The push handles support the weight of the wheelchair and you and can be used to safely lift you and your chair off the ground. 	pass/fail

The wheelchair passes the impact load test if the test results are as shown in Table 13.

Table 13 — Results of impact load test

Impact load test	Requirements for pass	Disclosure format
Seat	<ul style="list-style-type: none"> The seat will not rip when you flop into the chair. 	pass/fail
Backrest	<ul style="list-style-type: none"> The backrest will hold you when you fall back against it. 	pass/fail
Drop test	<ul style="list-style-type: none"> The chair will still open and roll if someone drops it while unloading it from the boot (trunk) of the car. 	pass/fail
Rolling – wheels and/or castors	<ul style="list-style-type: none"> The front wheels or castors will not deform when the wheelchair hits a kerb or pothole in the pavement. 	pass/fail
Footrest	<ul style="list-style-type: none"> The footrest will not bend when you hit a kerb. 	pass/fail
Armrest drop	<ul style="list-style-type: none"> The armrest will still fit on the chair after it is dropped on the floor. 	pass/fail
Loaded drop	<ul style="list-style-type: none"> The rear wheel will not bend if the chair is dropped off a kerb onto one wheel. 	pass/fail

If the wheelchair passes all the static load tests, it will probably not fail under the conditions listed in Table 13, and the wheelchair components will still be adjustable and removable. If the wheelchair passes all the impact tests, you know that there was no change in its structure or function after the impacts.

7.2.8 Flammability

7.2.8.1 Will the wheelchair go up in flames if I smoke in my chair?

If you, your friends, or co-workers smoke, you should not overlook the results of this test. A cigarette dropped onto the wheelchair upholstery could ignite the chair.

7.2.8.2 Determination of flammability

A test procedure is given in ISO 7176-16:1997, *Wheelchairs — Part 16: Resistance to ignition of upholstered parts — Requirements and test methods*.

The test procedure is performed in accordance with ISO 8191-1:1987, *Furniture — Assessment of the ignitability of upholstered furniture — Part 1: Ignition source: smouldering cigarette*, and ISO 8191-2:1988, *Furniture — Assessment of ignitability of upholstered furniture — Part 2: Ignition source: match-flame equivalent*. These are pass or fail tests.

Disclosure format (as reported by manufacturers)

Name of test	Test result
Resistance to ignition	pass/fail

See Figure 45.

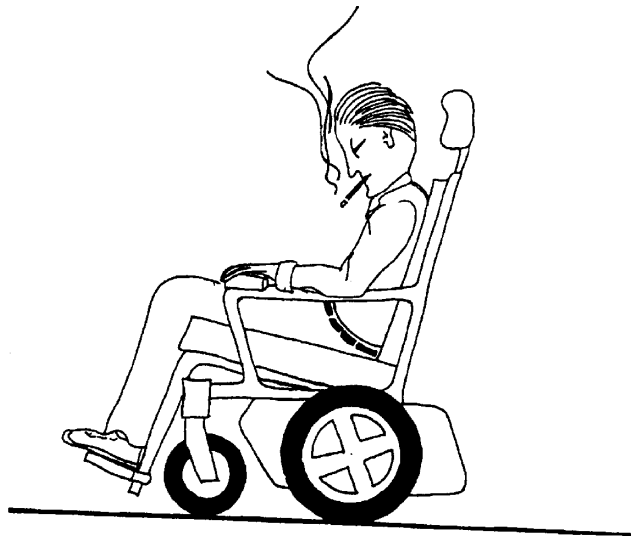

Figure 45 — Smoking in your wheelchair could lead to a hazardous situation!

7.2.8.3 Interpretation of results — Flammability

This test applies only to upholstery supplied by the wheelchair manufacturer, not to any cushions that you add to the chair. A lit cigarette should not ignite the upholstery. Cushions and supports added after purchase may not have been subjected to the flammability test. If you are a smoker or you spend time with people who smoke, you should choose a wheelchair that passes this test.

7.2.9 Battery chargers

7.2.9.1 How safe is the battery charger?

The safe operation of battery chargers is an important issue, since you must recharge your batteries regularly. You will want to know if the charger could be damaged if you or the person helping you accidentally hooked up the battery cables backward. It is important to use the appropriate charger with your batteries; some chargers are capable of charging both lead acid and gel cell batteries. The following test determines whether the battery charger meets certain safety requirements so that neither you nor your battery charger are harmed during normal operation.

7.2.9.2 Battery chargers test

A test procedure is given in ISO 7176-14:1997, *Wheelchairs — Part 14: Power and control systems for electric wheelchairs — Requirements and test methods*.

A comprehensive set of test procedures is performed on battery chargers for lead acid batteries. All of these tests are pass/fail. See Table 14.

Table 14 — Tests on battery chargers

Requirements for pass	Disclosure format
Battery chargers shall meet IEC standards to ensure electrical safety.	pass/fail
For battery chargers having more than one rated d.c. output voltage, it shall not be possible to change the voltage setting without a tool.	pass/fail
For battery chargers with outputs suitable for more than one type of battery (e.g. lead acid and gel cell), the selection device shall be conspicuously marked on the outside of the case with the type of battery selected.	pass/fail
The charger shall clearly indicate when it is correctly connected to batteries	pass/fail
Reverse polarity connection of the output to a battery shall not damage the charger and it shall not be possible to energise the output circuits.	pass/fail
Circuit protection devices will need to be reset or replaced before the charge will operate normally after reverse polarity connection.	pass/fail
There shall be a delay of not less than 0,5 s before the output circuit is energised when connection to the battery is made after the charger has been switched on.	pass/fail
Chargers shall clearly indicate the rated capacity of the batteries that they will charge to 80 % of rated capacity in a period not exceeding eight hours and shall demonstrate that capacity.	pass/fail

Disclosure format (as reported by manufacturers)

Name of test	Test result
Overall battery charger requirements	pass/fail

See Figure 46.

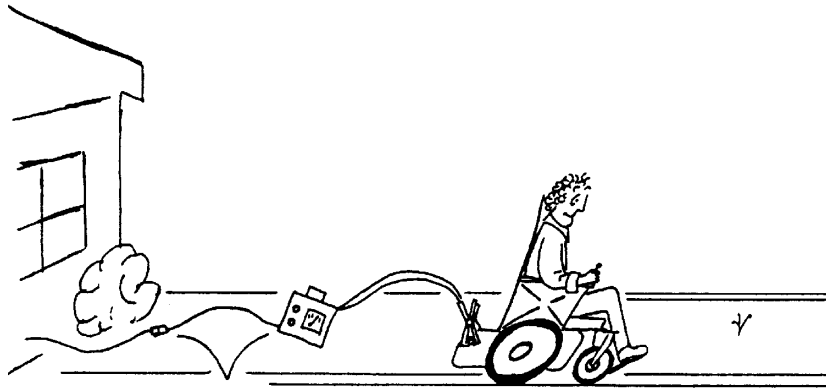

Figure 46 — For obvious safety reasons it shouldn't be possible to drive your powered chair with the charger plugged in ...

7.2.9.3 Interpretation of results — Battery chargers

If the manufacturer reports that the wheelchair passes the battery charger test for lead acid batteries, the battery charger meets the requirements listed in Table 14.

If you plan to travel in a country in which the standard voltage is different than that of your country, your charger may not work. In the United States, the standard voltage is 110 V; in Europe the standard is 220 V. To use a 110-V charger in Europe, a transformer is required to convert the 220 V down to 110 V. To find a transformer, you will need to know the amount of current that your charger draws so that a transformer of the appropriate size is located. The ideal situation is to obtain a 220-V charger compatible with your wheelchair. Battery chargers are also available that can be switched from 110 V to 220 V.

7.3 Dimensions

7.3.1 General

Dimensional information determined by the test procedures is very different from wheelchair measurements currently reported by most manufacturers. Using the test procedures, chairs are measured with a test dummy sitting in the chair, which more accurately represents the true dimensions of the wheelchair when it is occupied. The biggest problem with the dimensional information provided by manufacturers has been that the size of the wheelchair frame was measured using different methods, resulting in information that could not be compared among manufacturers. If you have not already done so, you may want to read Clause 5, "Incorporating personal body characteristics", for information on seating dimensions.

The following three subclauses provide dimensional information and explain how these measurements relate to you and your environment in connection with

- a) overall dimensions,
- b) seating dimensions, and
- c) mass.

7.3.2 Overall dimensions

7.3.2.1 How big is the wheelchair or scooter?

If you live in an apartment with a small bathroom, or if there are narrow doorways in your home or office, you will need to consider the overall size of the wheelchair when you make your selection. In such situations three- and four-wheeled scooters have a distinct advantage. Scooters are generally narrow and can usually make

very sharp turns. This test also provides information that is important if you need to put your chair or scooter on a wheelchair lift or get the wheelchair into your van or car (automobile) for transport. You want your wheelchair to fit into your environment, or at least not significantly hinder access to your home, office or car. See Figure 47.

Users of full-sized powered wheelchairs have a choice between a standard folding cross-frame and a power-base configuration. If there is a possibility that you will need to increase the width of your seat in the future, you may want to consider a full-sized power-base chair. A power-base chair can accommodate an increase in seat width without increasing the overall width of the chair, up to a certain point. Obviously, if your seat is wider than the base itself, an increase in seat width will increase the overall wheelchair width.

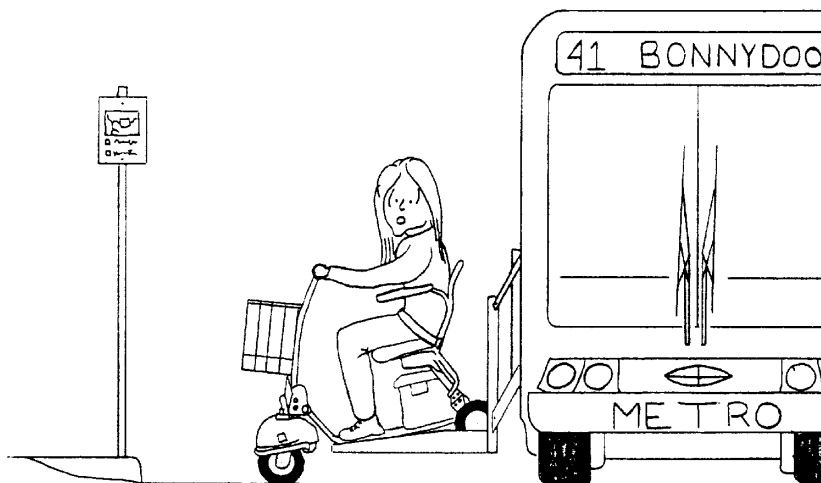

Figure 47 — Three- and four-wheeled scooters, while more manoeuvrable, tend to have longer wheelbases. Make sure the overall dimensions of your powered wheelchair will be compatible with your lifestyle.

7.3.2.2 Determination of overall dimensions

A test procedure is given in ISO 7176-5:1986, *Wheelchairs — Part 5: Determination of overall dimensions, mass and turning space.*

A wheelchair is measured in the fully opened and folded positions. These dimensions essentially represent the maximum size box that would be required to contain the wheelchair in a given configuration.

Disclosure format (as reported by manufacturers)

Name of test	Test result
Overall length without leg support and footrest	___ mm (___ inches)
Overall width	___ mm (___ inches)
Minimum folded length	___ mm (___ inches)
Minimum folded width	___ mm (___ inches)
Minimum folded height	___ mm (___ inches)

For a list of additional information not required for disclosure in the product literature, see Annex A.

7.3.2.3 Interpretation of results — Overall dimensions

This test discloses the dimensions of a chair in both the open and folded positions. Since all of the chairs are measured using the same method, you will be able to make true comparisons between chairs from different manufacturers. The overall dimensions will give you the size of the wheelchair with no parts removed, which will help you determine whether the wheelchair will fit through doorways, get around in your home or office, and fit on your wheelchair lift. Using the results of this test in conjunction with the manoeuvrability results, you will be able to select a chair to enhance your independence.

The folded wheelchair dimensions can help you determine whether the wheelchair will fit in the storage space available in a car or aeroplane.

7.3.3 Seating dimensions

7.3.3.1 Will the wheelchair fit me?

If you have ever sat in a poorly fitted wheelchair, you know why this information is critical. Not all wheelchairs are designed to fit every body shape, size and proportion. An improperly fitted wheelchair can result in discomfort, medical complications, and a decrease in your functioning. To understand how to choose the best fit, see Clause 5, "Incorporating personal body characteristics."

Before you set your mind on a particular wheelchair based on its performance, examine the seat dimensions and adjustability to make sure it will fit. If you do not fit correctly in the chair, all the other features and benefits may be useless.

7.3.3.2 Determination of seating dimensions

A test procedure is given in ISO 7176-7:1998, *Wheelchairs — Part 7: Measurement of seating and wheel dimensions*.

Because the dimensions of a wheelchair seat may vary from an unloaded state to a loaded state, a reference loader gauge is placed in the wheelchair during the measurement process. For wheelchairs with adjustable features, each measurement is made with variations in adjustments such that the minimum and maximum measurements are obtained.

Disclosure format (as reported by manufacturers)

Name of test	Test result
Seat plane angle	___ degrees
Maximum seat width	___ mm (___ inches)
Seat depth	___ mm (___ inches)
Seat surface height at front edge (to floor)	___ mm (___ inches)
Backrest angle	___ degrees
Backrest height	___ mm (___ inches)
Headrest height above seat	___ mm (___ inches)
Footrest to seat distance	___ mm (___ inches)
Leg to seat surface angle	___ degrees
Armrest height	___ mm (___ inches)

Front of armrest to backrest	___ mm (___ inches)
Armrest length	___ mm (___ inches)
Distance between armrests	___ mm (___ inches)
Front location of armrest structure	___ mm (___ inches)

See Annex A for additional dimensional information that is not required to be disclosed in the technical product literature.

See Figure 48.



Figure 48 — Don't buy a wheelchair that doesn't fit properly!

7.3.3.3 Interpretation of results — Seating dimensions

If you know what seating dimensions are appropriate for you, the results of this test will provide the information you need to determine which wheelchairs will fit you. A range of values indicates that the wheelchair is adjustable.

7.3.4 Mass (weight)

7.3.4.1 How heavy is the chair?

Powered wheelchairs are very heavy. However, weight does not affect the performance of a powered chair as it does for a manual chair. Nor will you be tossing the wheelchair into the back of your car single-handedly. So why do you need this information? Some models of powered chairs are considered transportable. It is important to see how much the “transportable” components weigh and how much you will have to disassemble to get to the lightest component. Three- and four-wheeled scooters generally are more transportable than full-sized wheelchairs because a scooter usually disassembles into seat, base, steering tiller and batteries. A full-sized powered wheelchair disassembles into: frame, battery box, and controller. Power-base chairs disassemble in the same way and usually have a removable seating system.

See Figure 49.

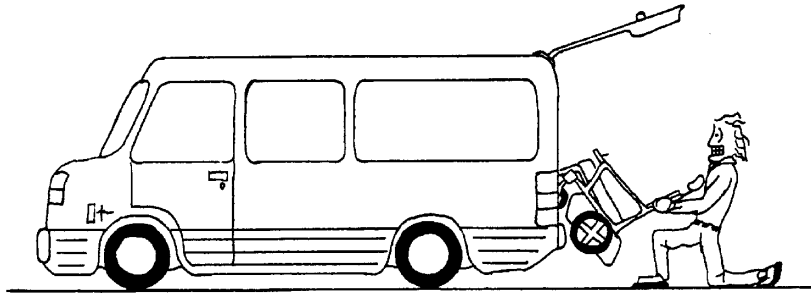

Figure 49 — The weight of a powered chair is a significant issue if you don't have a lift ...

7.3.4.2 Determination of mass

A test procedure is given in ISO 7176-5:1986, *Wheelchairs — Part 5: Determination of overall dimensions, mass and turning space*.

The total mass of the wheelchair equipped with standard armrests, legrests, wheels and castors is measured.

Disclosure format (as reported by manufacturers)

Name of test	Test result
Total mass of wheelchair and accessories	___ kg (___ lb)

Additional information not required for disclosure in the product literature:

Mass of each removable component of the wheelchair	___ kg (___ lb)
--	-----------------

7.3.4.3 Interpretation of results — Mass

Manufacturers are required to disclose only the total mass (weight) of the wheelchair, including all accessories, in the pre-sale product literature. The mass of each removable component is not required for disclosure, but is available upon request. If you travel in your powered wheelchair, you may encounter a situation in which your wheelchair must be disassembled and loaded into a small vehicle for transport. The mass of the components may be useful information to have to determine how many items will need to be disassembled and whether the person assisting you will be able to lift each component. The batteries are usually the heaviest removable component. Many airlines require that batteries be removed from a powered wheelchair during travel. A single wheelchair battery weighs anywhere from 30 lbs to 50 lbs. If the batteries are housed in a single battery box, the person assisting you must be able to lift about 100 lbs. If the batteries are housed in two separate boxes, transporting them will be easier.

If you travel, another important consideration is the time required to disassemble and reassemble your wheelchair, including removal and reinstallation of the batteries, and whether tools are required.

Annex A (informative)

Additional information not required for disclosure in the manufacturer's technical product literature

NOTE If the wheelchair manufacturer claims to be in compliance with International Standards on wheelchairs, the results of any of the tests below should be provided to you upon direct request to the manufacturer. If the manufacturer is not willing to provide the information listed below, the manufacturer is not in compliance with the ISO test procedures.

For terms and definitions, see ISO 6440:1985, *Wheelchairs — Nomenclature, terms and definitions*.

The following is a list of International Standards that apply to both manual and powered wheelchairs, giving additional information that can be requested from the manufacturer.

ISO 7176-1:1999, *Wheelchairs — Part 1: Determination of static stability*

- Includes brakes off, wheels blocked

ISO 7176-5:1986, *Wheelchairs — Part 5: Determination of overall dimensions, mass and turning space*

- Dimensions and mass of each removable component of the wheelchair
- Dimensions and mass of each wheelchair component
- Minimum turning radius
- Overall height with backrest in the upright position
- Minimum volume
- Minimum dimensions of largest component
- Dimensions of nonfolding wheelchair prepared for storage
- Dimensions of a folded wheelchair for accommodation in a car

ISO 7176-7:1998, *Wheelchairs — Part 7: Measurement of seating and wheel dimensions*

- Effective seat width
- Backrest width
- Headrest in front of the backrest
- Footrest clearance
- Footrest length
- Footrest-to-leg angle
- Armrest width
- Armrest angle
- Vertical location of wheel axle

ISO/TR 13570-1:2005(E)

ISO 7176-8:1998, *Wheelchairs — Part 8: Requirements and test methods for static, impact and fatigue strengths*

Manufacturers may choose to disclose the degree to which their wheelchairs perform beyond the minimum recommended values in the following areas:

Static strength

Armrest downward

Footrest downward

Tipping levers downward

Hand grips

Armrest upward

Footrest supports upward

Push handles upward

Impact strength

Seat impact load test

Backrest impact load test

Drop test impact load test

Rolling impact load test wheels and/or castors

Handrim impact load test

Footrest impact load test

Armrest drop impact load test

Loaded drop impact load test

Fatigue strength

Double drum test

Kerb drop test

ISO 7176-15:1996, *Wheelchairs — Part 15: Requirements for information disclosure, documentation and labelling*

ISO 7193:1985, *Wheelchairs — Maximum overall dimensions*

The following is a list of those test procedures that apply to powered wheelchairs only:

ISO 7176-2:2001, *Wheelchairs — Part 2: Determination of dynamic stability of electric wheelchairs*

- Starting uphill, one or more wheels lift from the test plane
- Lifting or tipping of wheelchair during maximum turning manoeuvre

ISO 7176-3:2003, *Wheelchairs — Part 3: Determination of effectiveness of brakes*

- Wheel lock lever force
- Forward horizontal and automatic braking distance
- Reverse horizontal minimum braking distance and automatic braking distance
- Force required to operate dynamic braking lever

ISO 7176-4:1997, *Wheelchairs — Part 4: Energy consumption of electric wheelchairs and scooters for determination of theoretical distance range*

- Indoor and outdoor energy consumption
- Watt hours per kilometre

ISO 7176-6:2001, *Wheelchairs — Part 6: Determination of maximum speed, acceleration and deceleration of electric wheelchairs*

- Maximum acceleration forward
- Maximum acceleration rearward
- Maximum retardation forward

ISO 7176-14:1997, *Wheelchairs — Part 14: Power and control systems for electric wheelchairs — Requirements and test methods*

- Force necessary to operate joystick
- Force necessary to operate pushbutton, rocker, and keypad switches
- Force necessary to operate toggle switches
- Force necessary to operate pneumatic switches (positive and negative)

Bibliography

Articles

- [1] AXELSON, PETER. Power Chairs. *Paraplegia News*, **47** (4), Apr 1993, pp. 14-31
- [2] AXELSON, PETER. Chairs, Chairs, Everywhere! *Sports 'n Spokes*, **19** (6), Mar/Apr 1994, pp. 15-63
- [3] AXELSON, PETER. Wheelchair comparison. *Sports 'n Spokes*, **18** (6), Mar/Apr 1993, pp. 34-70
- [4] AXELSON, PETER, DENISE CHESNEY, and SHARI GOODMAN. Lightweight Choice. *Mainstream*, **18**(q), June/July 1994, pp. 22-23¹⁾
- [5] AXELSON, PETER, and LYNN PHILLIPS. Wheelchair Standards: Pushing for a New Era. *Homecare Magazine*, Oct 1989¹⁾
- [6] AXELSON, PETER, and ZOE WOOD. Wheelchair Standards and You. *Paraplegia News*, **47** (10), Oct 1992, pp. 54-55¹⁾
- [7] BRYANT, LYNN. Well-Done, Wheelchair Standards Committee!! *RESNA News*, **2** (5), Sept/Oct 1990, pp. 1,4¹⁾
- [8] BRYANT, LYNN. Wheelchair Standards Ready to Roll. *Team Rehab Report.*, May/June 1991, pp. 44-45¹⁾
- [9] Guidelines for Application of Wheelchair Standards, ISO/TC 173, SC 1, Working Group 1, Document 524, June 1991
- [10] HORN, JOHN. U.S. Committee Adopts Wheelchair Standards. *P.T. Bulletin*, **6** (6), Feb 13 1991, pp. 4, 34¹⁾
- [11] MARLOWE, DONALD E. Assessing Wheelchair Performance: The Role of Regulations and Standards, Wheelchair IV Report of a Conference on the State-of-the-Art of Powered Wheelchair Mobility. *RESNA Press*, Dec. 7-9, 1988, pp. 61-63¹⁾
- [12] MCLAURIN, COLIN. Wheelchair Development, Standards, Progress, and Issues: A Discussion with Colin McLaurin. *VA Journal of Rehabilitation Research & Development*, **23** (2), April 1986, pp. 48-51¹⁾
- [13] MCLAURIN, COLIN A., and PETER AXELSON. Wheelchair Standards: An Overview" *VA Journal of Rehabilitation Research and Development Clinical Supplement No.2: Choosing a Wheelchair System*, March 1990, pp.100-103¹⁾
- [14] Presentation of Test Results for Prescribers and Users, ISO/TC 173 SC 1, Working Group 5, Document 97, May 7 1985
- [15] PRONSATI, MICHELLE P. Standardization Will Bring Better Products to Wheelchair Consumers. *Advance for Physical Therapists*, **2** (36), Sept 9 1991, pp. 22-23, 42
- [16] SHEPHERD, MARK. Tuning Your Lightweight Chair. *Action Digest.*, Jul/Aug 1992, pp. 6-7
- [17] Using the Wheelchair Standards to Choose and Prescribe Wheelchairs, ISO/TC 173, SC 1, Working Group 5, Document 223, May 1988

1) Available through PAX Press, a division of Beneficial Designs, Inc., Santa Cruz, California, United States, <paxpress@beneficialdesigns.com>, (831) 429-8746, (831) 423-8450 fax.

- [18] Using Wheelchair Standards to Assist in Wheelchair Prescription and Selection, ISO/TC 173, SC 1, Working Group 5, Document 191, R-286, June 1991

Books and pamphlets

- [19] MINKEL, JEAN. *Wheelchair Standards: But I am Not an Engineer!* Helen Hayes Hospital, West Haverstraw: 1992
- [20] WILSON, A. BENNETT. *How to Select and Use Manual Wheelchairs*. Topping, VA: Rehabilitation Press, 1992

Other resources

International Standards on wheelchairs can be obtained from your country's member body (for example, RESNA, BSI).

Copies of the complete ANSI/RESNA Wheelchair Standards can be purchased from:

RESNA
1700 N. Moore Street, Suite 1540
Arlington, VA 22209
(703) 524-6686, (703) 524-6630 fax

Publications available through ABLEDATA include:

Wheelchairs for Children
Manual Wheelchairs
Powered Wheelchairs
Informed Consumer Guide to Wheelchair Selection

ABLEDATA/NARIC
8455 Colesville Road, Suite 935
Silver Spring, MD 20910
(800) 346-2742, (301) 587-1967 fax

PAX Press
P.O. Box 8317
Santa Cruz, CA 95061-8317
(831) 429-8476, (831) 423-8450 fax

RESNA Press
1700 N. Moore St., Suite 1540
Arlington, VA 22209

Trade and professional journals

Action Digest
P.O. Box 508
Amherst, OH 44001-0508
(216) 985-2036

Assistive Technology
RESNA Press
1700 N. Moore St., Suite 1540
Arlington, VA 22209

ISO/TR 13570-1:2005(E)

Journal of Rehabilitation Research & Development
Department of Veterans Affairs
Scientific & Technical Publications Section
103 S. Gay St.
Baltimore, MD 21202

Mainstream Magazine
P.O. Box 370598
San Diego, CA 92137-0598
(619) 234-3138

Paraplegia News and Sports 'n Spokes
Paralyzed Veterans of America
2111 E. Highland Avenue, Suite 180
Phoenix, AZ 85016-4702
(602) 224-0500

Quickie Newsletter
Quickie Designs, Inc.
2842 Business Park Avenue
Fresno, CA 93727
(209) 292-2171

Team Rehab
Miramar Publishing Co.
6133 Bristol Parkway
Culver City, CA 90230
(310) 337-9717

70

ICS 11.180.10

Price based on 70 pages