

First edition
2012-09-01

**Compressors — Classification —
Complementary information to ISO 5390**

*Compresseurs — Classification — Information complémentaire à
l'ISO 5390*



Reference number
ISO/TR 12942:2012(E)

© ISO 2012



COPYRIGHT PROTECTED DOCUMENT

© ISO 2012

All rights reserved. Unless otherwise specified, no part of this publication may be reproduced or utilized in any form or by any means, electronic or mechanical, including photocopying and microfilm, without permission in writing from either ISO at the address below or ISO's member body in the country of the requester.

ISO copyright office
Case postale 56 • CH-1211 Geneva 20
Tel. + 41 22 749 01 11
Fax + 41 22 749 09 47
E-mail copyright@iso.org
Web www.iso.org

Published in Switzerland

Contents

Page

Foreword	iv
Introduction.....	v
1 Scope	1
2 Design classes.....	1
2.1 General	1
2.2 Classification by equipment type	3
2.3 Classification of compressor apparatuses by operation principles	3
2.4 Classification of compressor machines by operation principles	5
2.5 Design classes of compressor machines.....	6
3 Functional classes of the compressor equipment, terms and definitions.....	22
3.1 General	22
3.2 Basic functional classes of compressor machines.....	23
3.3 Formation principles of derivative functional classes for compressor machines.....	27
3.4 Functional classes of compressor apparatuses.....	32
4 Design classes of the aggregated compressor equipment, terms and definitions.....	34
4.1 General	34
4.2 Design classes of geared mechanical compressors	39
4.3 Design classes of driver-compressors	40
4.4 Design classes of geared driver-compressors	46
4.5 Design and service-duty classes of compressor plants	48
4.6 Design classes of packaged compressor plants	51
Annex A (informative) Design, functional and service-duty classification.....	54
Bibliography.....	59

Foreword

ISO (the International Organization for Standardization) is a worldwide federation of national standards bodies (ISO member bodies). The work of preparing International Standards is normally carried out through ISO technical committees. Each member body interested in a subject for which a technical committee has been established has the right to be represented on that committee. International organizations, governmental and non-governmental, in liaison with ISO, also take part in the work. ISO collaborates closely with the International Electrotechnical Commission (IEC) on all matters of electrotechnical standardization.

International Standards are drafted in accordance with the rules given in the ISO/IEC Directives, Part 2.

The main task of technical committees is to prepare International Standards. Draft International Standards adopted by the technical committees are circulated to the member bodies for voting. Publication as an International Standard requires approval by at least 75 % of the member bodies casting a vote.

In exceptional circumstances, when a technical committee has collected data of a different kind from that which is normally published as an International Standard ("state of the art", for example), it may decide by a simple majority vote of its participating members to publish a Technical Report. A Technical Report is entirely informative in nature and does not have to be reviewed until the data it provides are considered to be no longer valid or useful.

Attention is drawn to the possibility that some of the elements of this document may be the subject of patent rights. ISO shall not be held responsible for identifying any or all such patent rights.

ISO/TR 12942 was prepared by Technical Committee ISO/TC 118, *Compressors and pneumatic tools, machines and equipment*, Subcommittee SC 6, *Air compressors and compressed air systems*.

Introduction

Classification and terminology standards are fundamental to the identification of a product for using in industrial and trade communications, education, information search, data processing, research, development, inventing, patenting, etc. It is intended that these standards be based on the latest technical achievements and classification theories, cover all viable modern equipment design types, exclude ambiguity, be adapted to easy translations into different languages by exact terms, and be flexible and open to new innovations. This Technical Report is intended to contribute essentially to obtaining these aims for a possible subsequent revision of ISO 5390.

The main modern problems in compressor classification and terminology are associated with rapid development and implementation of new design types. In addition, many manufacturers include in a single non-separable compressor package, not only an aftercooler, but also a receiver, dryer, etc.. In these conditions, it is important to establish and maintain unified patterns and principles for forming new derivative and composed terms by using a few basic original terms as well as using, as far as possible, established professional terms which have emerged spontaneously.

The problems related to the classification of compressor equipment are complicated by the wide spectrum and diversity of application fields, resulting in a great number of applicability and performance criteria, such as:

- compression principles;
- basic design features;
- energy forms used (electricity, fuel heat, etc.) and driver types;
- cooling agents (air, water, etc.) and methods;
- lubrication conditions (oil-free or contaminated with oil);
- mobility, transportability;
- prefabrication level (packaged and factory-assembled compressor, compressor plant, etc.);
- operation modes and service parameters;
- range of functions (compression, energy conversion, cooling, drying, etc.) and appropriate structural composition of the equipment.

Neither identification of the compressor equipment and its application fields nor selection of compressors for specific services and comparison of their technical and economical parameters are possible without knowledge of this information. That is why it is intended that the attributes listed in this Technical Report serve as a basis for the practical multi-dimensional classification system of compressor equipment.

Some explanatory notes and methodical approaches are presented in Annex A.

Compressors — Classification — Complementary information to ISO 5390

1 Scope

This Technical Report gives a classification of modern compressor types and their definitions.

This Technical Report presents terms for use in technical and contractual specifications, manufacturer's literature, information searches and data processing systems, patent information, educational publications for students, service and maintenance instructions, industrial statistics and market surveys, as well as in design, quality, safety, testing and other standards, norms, regulations and codes.

It is intended that adequate technical and economical comparison and evaluation of compressor alternatives for specific application conditions be performed with identical functional, mobility, service pressures and service media classes, as well as with equal capacity ratings.

2 Design classes

2.1 General

The general hierarchy of compressor design classes is given in Figure 1.

Design classes specify the basic working principles and conceptual engineering philosophy of modern compressors being operated, marketed, manufactured, developed, investigated or invented. The classification tables in 2.2 to 2.5 contain preferred terms of basic compressor classes, their definitions and graphical illustrations. Graphical materials are presented only as examples. Non-preferred synonyms are given in parentheses. Special definitions are not given for those subclasses where the wording of the terms characterizes sufficiently basic design features and attributes of the compressor types. More general high-level terms can be used in the technical documentation instead of low-level particular subclasses, such as "compressor", "compressor plant" and "compressor equipment" after the first full description of functional and design subclasses, and in all those cases where there is no possibility of confusion with other subclasses or there is no need to differentiate between specific subclasses.

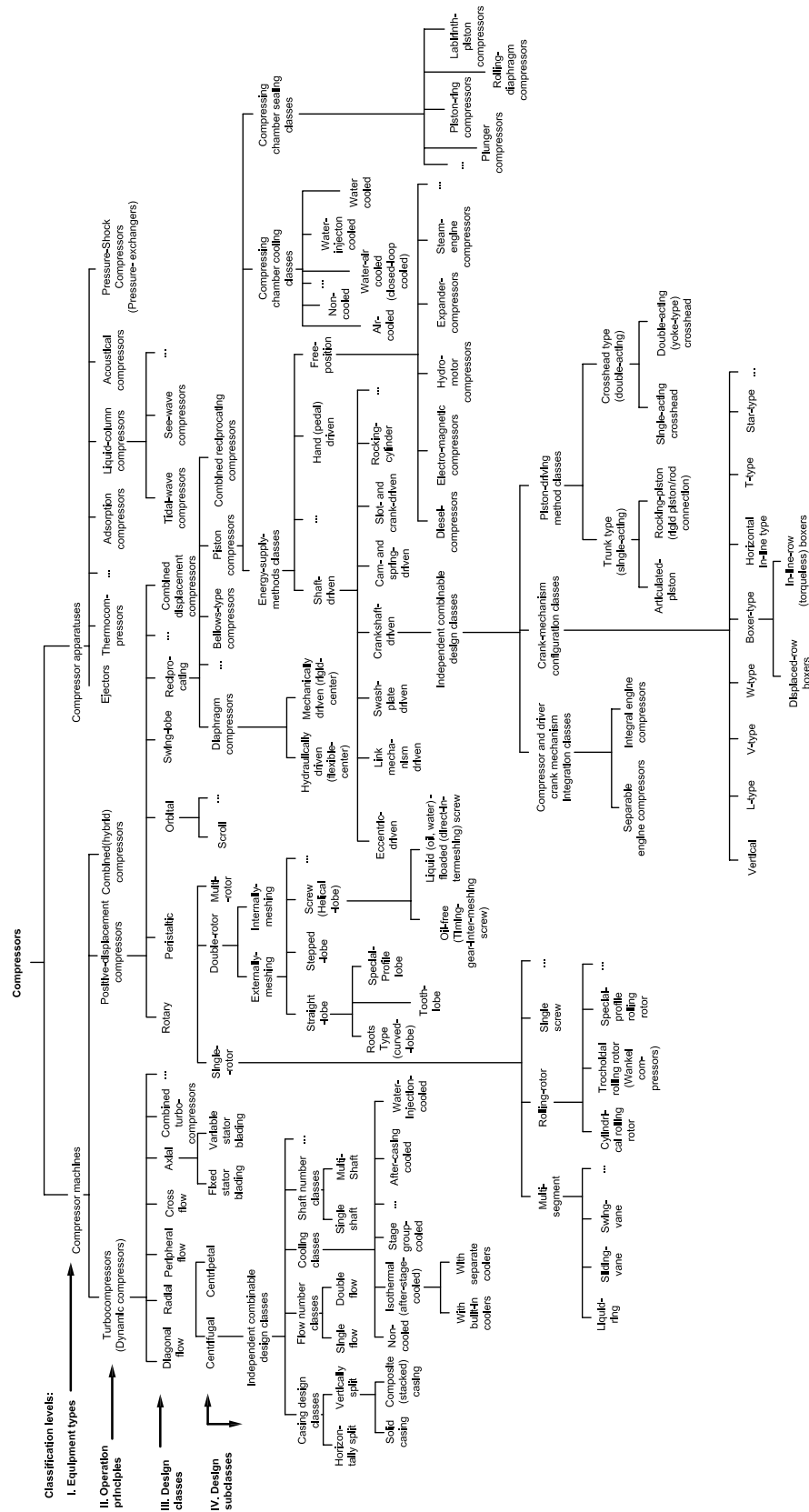
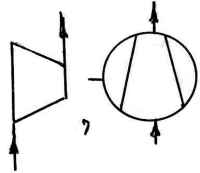
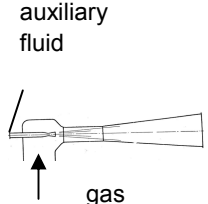
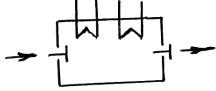
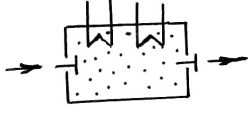

Figure 1 — Design classes of compressors

2.2 Classification by equipment type

Class, term	Subclass and definition	Illustration (example only)
Compressor (generic term)	A machine or apparatus converting different types of energy into the potential energy of gas pressure for displacement and compression of gaseous media to any higher pressure values above atmospheric pressure with pressure-increase ratios exceeding 1,1. NOTE 1 Similar equipment with pressure-increase ratio values of up to 1,1 is regarded as ventilator.	
	Compressor machine NOTE 2 In some design types of compressor machine, intermediate liquid service media can be used for driving-force transmitting from one solid member to the other one (e.g. in electrically/hydraulically driven piston and diaphragm compressor).	See 2.3 to 2.5 for specific classes
	Compressor apparatus	See 2.3 to 2.5 for specific classes

2.3 Classification of compressor apparatuses by operation principles

Class, term	Subclass	Definition	Illustration (example only)
Compressor apparatus	Ejector	A compressor apparatus of dynamic type, comprising suction chamber, cylindrical throat and diffuser, in which the gas-pressure increase is obtained in continuous flow by initial increasing its kinetic energy by mechanical action of the motive high-velocity auxiliary fluid stream entraining the gas into the accelerating mixed stream, and successive conversion of the kinetic energy into the potential energy of the mixture pressure by deceleration of the mixture flow in the diffuser, the high velocity of the motive auxiliary-fluid stream being created by its expansion in the nozzle from pressurized state to the initial or lower pressure of the gas being compressed.	
	Thermo-compressor	A compressor apparatus of displacement type in which the gas pressure increase, its discharge and gas intake are obtained by cyclically heating and cooling of the closed volumes of the gas.	
	Adsorption compressor	A compressor apparatus of displacement type in which the gas pressure increase, its discharge and gas intake are obtained by cyclical adsorption of the gas by special adsorbents such as metal hydrides and its desorption at higher pressures by changing temperature conditions.	

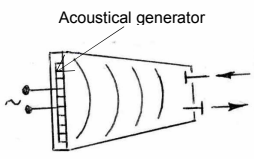
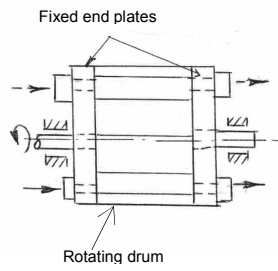
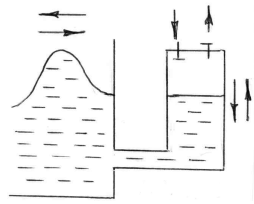
Class, term	Subclass	Definition	Illustration (example only)
Compressor apparatus (continued)	Acoustical compressor	<p>A compressor apparatus of displacement type in which the gas pressure increase, its discharge and gas intake are obtained by cyclical formation of low- and high-pressure phases in the closed volumes of the gas due to actions of pressure waves emitted by an acoustical generator</p>	
	Pressure – shock compressor (Pressure exchanger)	<p>A compressor apparatus of displacement type in which the compression of successive volumes of the gas is effected by shock waves created by the second high-pressure energy-carrying gas in several longitudinal through channels arranged circumferentially on the cylindrical drum, these channels being cyclically closed by rotation of the drum between fixed end plates having inlet/outlet ports and blind zones, the shock waves being generated by cyclical exposure of channel ends to the energy-carrying-gas manifold, and inlet/outlet of both fluids being achieved by synchronization of drum-rotating speed in respect to the fixed inlet/outlet ports with the velocity of pressure-wave propagation.</p> <p>NOTE 1 The rotating drum is not imparting any energy to the gas to be compressed. Its rotation synchronized with shock wave velocity is an auxiliary movement only ensuring control of fluid flows. The drum can be driven by a small auxiliary prime mover or any other power transmitting shaft.</p> <p>NOTE 2 The shock-wave propagation from one channel end to another one and gas compression up to pressure equalization of two fluids in the channels occur essentially faster than mixing of fluids.</p>	
	Liquid-column compressor	<p>A compressor apparatus of displacement type in which admission and compression of successive volumes of the gas are performed periodically by forced expansion and diminution of a closed space(s) in the vertical casing of any form due to displacement of the auxiliary-liquid column in said casing.</p> <p>NOTE 1 The displacement of the auxiliary-liquid column can be generated by external renewable natural-energy sources, e.g. water waves.</p> <p>NOTE 2 The liquid-displacement source subclasses are:</p> <ul style="list-style-type: none"> — sea-wave driven compressors; — tidal-wave driven compressors. 	

2.4 Classification of compressor machines by operation principles

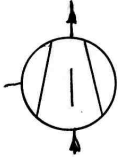
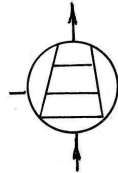
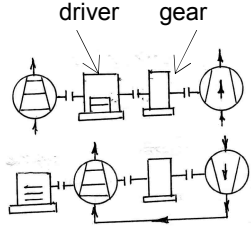
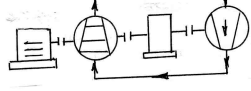
Class, term	Subclass	Definition	Illustration (example only)
Compressor machine	Dynamic compressor, turbocompressor	A compressor machine in which the gas pressure increase is achieved in continuous flow essentially by increasing its kinetic energy in the flow path of the machine due to acceleration to the high velocities by mechanical action of blades placed on a rapid rotating wheel and further transformation of the kinetic energy into the potential energy of the elevated pressure by successive deceleration of the said flow.	
	Positive-displacement compressor	<p>A compressor machine in which the admission and compression of successive volumes of the gaseous medium are performed periodically by forced expansion and diminution of a closed space(s) in a working chamber(s) by means of displacement of a moving member(s) or by displacement and forced discharge of the gaseous medium into the high-pressure area.</p> <p>NOTE The closed spaces with variable or displaceable volumes represent compression chambers. In one working chamber, there can be one or several variable-volume compression chambers.</p>	
	Combined compressor machine	A compressor machine in which the compression of gaseous medium or media is performed simultaneously or successively by dynamic and positive-displacement compressors driven by a common prime mover.	<p>Simultaneous compression</p>  <p>Successive compression</p> 

2.5 Design classes of compressor machines

2.5.1 Design classes of turbo compressors (dynamic compressors)

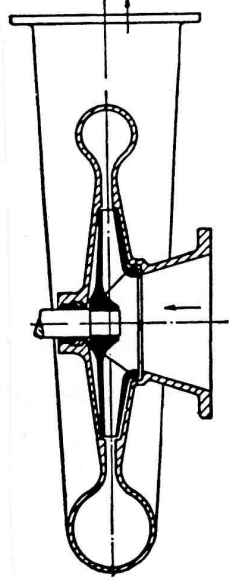
Class, term	Subclass	Definition	Illustration (example only)
Turbo compressor	Radial turbo-compressor (Radial-flow turbo-compressor)	<p>A turbo compressor in which the acceleration of the gas stream in the meridional plane is performed in radial direction with respect to the axis of rotation of the bladed wheel.</p> <p>NOTE 1 The subclasses of radial compressors are:</p> <ul style="list-style-type: none"> — radial centrifugal compressor; — radial centripetal compressor. <p>NOTE 2 The broader term “radial compressor” can be used instead of “centrifugal compressor” if there is no possibility of confusion with centripetal radial compressors.</p>	
	Centrifugal compressor	<p>A radial turbo compressor in which the acceleration of the gas stream is caused essentially by centrifugal forces and performed from the centre of the rotating wheel to its periphery.</p> <p>NOTE 3 The basic specific subclasses of the centrifugal compressors are:</p> <ul style="list-style-type: none"> a) flow-number classes of the rotating wheel: <ul style="list-style-type: none"> 1) single-flow compressor; 2) double-flow compressor; b) casing-design classes: <ul style="list-style-type: none"> 1) horizontally split compressor; 2) vertically split compressor with solid casing; 3) vertically split compressor with stacked casing; c) cooling-configuration classes: <ul style="list-style-type: none"> 1) non-cooled compressor; 2) isothermal (after-stage-cooled compressor): <ul style="list-style-type: none"> a) with built-in coolers; b) with separate coolers; 3) stage-group-cooled (sectionally cooled) compressor; 4) after-casing cooled compressor; 5) water-injection-cooled compressor; d) shaft-number classes: <ul style="list-style-type: none"> 1) single-shaft compressor; 2) multi-shaft compressor. <p>NOTE 4 Gas cooling system is a component part of the aggregated compressor equipment (compressor plant); however, in spite of this gas cooling methods influence also essentially the design of the compression mechanism (mechanical compressor).</p>	

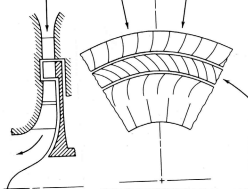
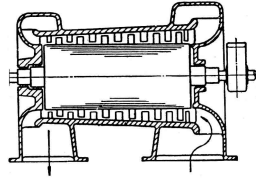
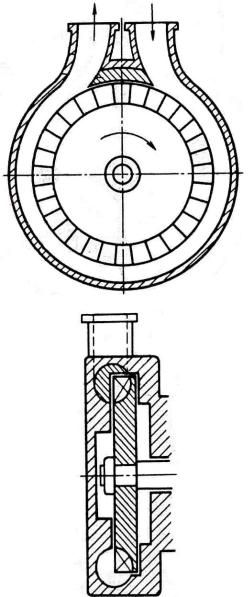
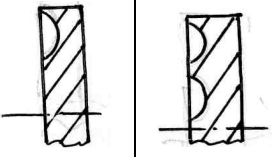
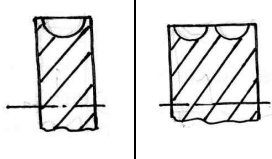
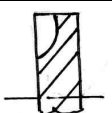
Class, term	Subclass	Definition		Illustration (example only)
Turbo compressor (continued)	Radial turbo-compressor (Radial-flow turbo-compressor) (continued)	Centripetal compressor	A radial turbo compressor in which the gas stream is accelerated essentially by centripetal forces induced by mechanical action of blades placed circumpherentially on the rotating wheel and moves from its periphery to the centre.	
	Axial compressor (axial-flow compressor)	A turbo compressor in which the acceleration of the gas stream in the meridional plane is performed in the direction parallel to the axis of rotation of the bladed wheel. NOTE 5 The basic design subclasses of axial compressor are: — compressors with fixed stator blading; — compressor with variable stator blading.		
	Peripheral flow compressor (periflow compressor, vortex compressor, regenerative compressor, drag compressor, tangential compressor)	A turbo compressor in which the acceleration of the gas stream is performed by its composed resulting motion in peripheral (circumferential) direction in respect of the axis of rotation of the bladed wheel. NOTE 6 The resulting peripheral motion with helical screw-type flow pattern of the gaseous medium is composed of the radial motion in the rotor pockets under the centrifugal forces, the circulatory motion in the ring-shaped peripheral stator channel caused by centrifugal pressure gradient superimposed by the circumferential motion induced by rotation of the wheel. NOTE 7 The basic subclasses of peripheral-flow compressors according to configuration and location of bladed rotor channels are:		
a) side-channel compressor		1. single-side-channel compressor 2. multi-side-channel compressor	Individual definitions are not necessary because the wording of the terms characterizes sufficiently basic design features of the subclasses.	
b) peripheral-channel compressor		1. single-peripheral channel compressor 2. multi-peripheral channel compressor		
c) angle-channel compressor				

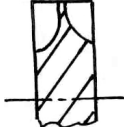
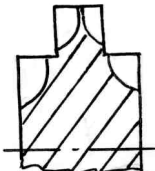
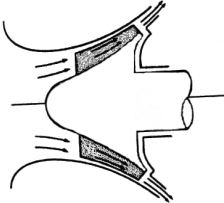
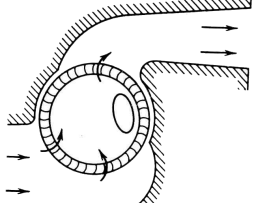
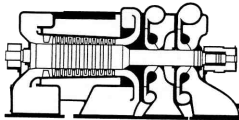
Class, term	Subclass	Definition	Illustration (example only)
Turbo compressor (continued)	Peripheral flow compressor (periflow compressor, vortex compressor, regenerative compressor, drag compressor, tangential compressor) (continued)	d) double-angle-channel compressor	
		e) stepped-channel compressor	
	Diagonal-flow compressor (mixed-flow compressor)	A turbo compressor in which the acceleration of the gas stream in the meridional plane is performed at acute angles between axial and radial directions to the axis of rotation of the bladed wheel.	
	Cross-flow compressor (transverse-flow compressor, diametrical compressor)	A turbo compressor in which the acceleration of the gas stream is performed in diametrical, cross-direction with respect to the axis of rotation of the bladed wheel thus action of two blade rows on the stream is achieved. NOTE 8 Fixed deflectors can be used inside the bladed wheel for better flow guidance between two rows of blades.	
	Combined turbo-compressor	A turbo compressor in which the compression of gaseous medium or media is performed simultaneously or successively in different types of turbo compressors driven by a common prime mover. NOTE 9 Subclasses of combined turbo compressors can be: — axial-radial turbo compressor; — diagonal-radial turbo compressor; — radial-peripheral turbo compressor, etc.	

2.5.2 Design classes of positive displacement compressors

2.5.2.1 General

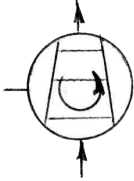
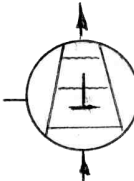
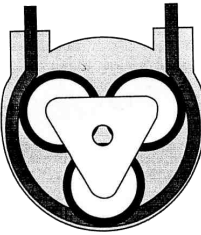
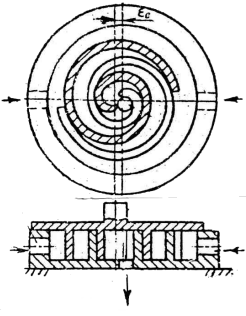
Class, term	Subclass	Definition	Illustration (example only)
Positive displacement compressor	Rotary compressor	<p>A displacement compressor in which gas admission and diminution of its successive volumes or its forced discharge are performed cyclically by rotation of one or several rotors in a compressor casing.</p> <p>NOTE 1 The rotor-number subclass are:</p> <ul style="list-style-type: none"> — Single-rotor compressor, — Double-rotor compressor, — Multi-rotor compressor. 	
	Reciprocating compressor	<p>A displacement compressor in which gas admission and diminution of its successive volumes are performed cyclically by straight-line alternating movement of a moving member(s) in a compression chamber(s).</p> <p>NOTE 2 Design subclasses of reciprocating compressors are:</p> <ul style="list-style-type: none"> — piston compressor; — diaphragm compressor; — bellows-type compressor. 	
	Peristaltic compressor	<p>A displacement compressor in which admission of the gas volumes and their forced discharge are performed cyclically by local squeezing of sections of a flexible pipe rested on arc-shaped support by rollers of an external rotor and by displacing the trapped gas volumes from low-pressure side to high-pressure area.</p> <p>NOTE 3 The inner flexible-pipe surface driven by the rollers represents the working member in the peristaltic compressors.</p>	
	Orbital compressor	<p>A displacement compressor in which gas admission and diminution of their successive volumes are performed cyclically by plain-parallel non-rotating orbital motion of the working member along the circular or other closed-curve path in the working chamber.</p> <p>Subclass: scroll compressor</p>	
	Scroll compressor	<p>An orbital compressor in which closed-space compression chambers are formed between two identical spiral bands inserted eccentrically in each other and their flat end cover plates, the volumes of said spaces being cyclically decreased and increased from periphery to the centre by orbital non-rotating plane-parallel motion of one spiral band inside the fixed one along the circular path.</p>	

Class, term	Subclass	Definition	Illustration (example only)
Positive displacement compressor (continued)	Swing-lobe compressor (oscillating-lobe compressor)	A displacement compressor in which gas admission and diminution of its successive volumes are performed by angular swinging (rocking) motion of one or several lobes around their axes in a cylindrical or partly cylindrical casing.	
	Combined positive-displacement compressor	A positive displacement compressor in which the compression of gaseous medium or media is performed simultaneously or successively in different types of positive displacement compressors driven by a common prime mover.	<p>Simultaneous compression</p> <p>Successive compression</p>

2.5.2.2 Design classes of single-rotor compressors

Class, term	Subclass	Definition	Illustration (example only)
Single-rotor compressor	Multi-segment compressor	<p>A single-rotor compressor in which the compressor chambers constitute circle segments in cross-section, their expansion and diminution being obtained by passing through the variable-height crescent-shaped space between the inner surface of the casing and eccentrically mounted rotor of the smaller diameter.</p> <p>NOTE 1 The design subclasses of multi-segment compressors are:</p> <ul style="list-style-type: none"> — liquid-ring compressor; — sliding-vane compressor; — swing-vane compressor. 	
	Liquid-ring compressor	A multi-segment compressor in which segment-shaped compression chambers are formed between the radial or forward-curved vanes of the eccentric rotor and rotating liquid layer created and maintained by rotating vanes and pressed concentrically to the inner surface of the casing by centrifugal forces.	

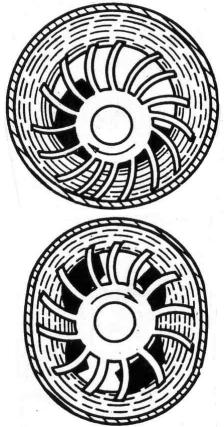
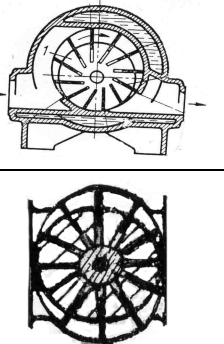
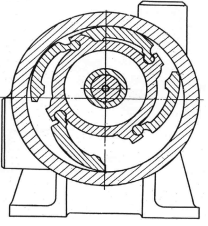
Class, term	Subclass	Definition		Illustration (example only)
Single-rotor compressor (continued)	Multi-segment compressor (continued)	Liquid-ring compressor (continued)	<p>Single-acting compressor</p> <p>Double-acting compressor (with two crescent-shaped spaces in the oval-type casing)</p>	
		Sliding-vane compressor	<p>A multi-segment compressor in which segment-shaped compression chambers are formed between the inner surface of the cylindrical casing and flat solid vanes sliding in radial or cord-shaped slots of the eccentric rotor and being constantly pressed to said surface by centrifugal forces.</p> <p>NOTE 2 The design subclasses are:</p> <ul style="list-style-type: none"> — single-acting compressor; — double-acting compressor. 	
		Swinging-vane compressor	<p>A multi-segment compressor in which segment-shaped compression chambers are formed between the inner surface of the cylindrical casing and curvilinear flexible or solid vanes rigidly connected or correspondingly pivoted by one of their ends to the rotor and being constantly pressed to the casing surface by centrifugal forces.</p> <p>NOTE 3 The design subclasses are:</p> <ul style="list-style-type: none"> — single-acting compressor; — double-acting compressor. 	
		Rolling-rotor compressor	<p>A single-rotor compressor in which the expansion and diminution of variable-volume compression chambers are performed by rolling of the eccentric rotor along the inner surface of the casing of the larger size, the axis of the rotor being circulating by its rotation around the casing axis.</p> <p>NOTE 4 The rotor-profile subclasses are:</p> <ul style="list-style-type: none"> — cylindrical-rolling-rotor compressor; — trochoidal-rolling-rotor compressor; — special profile rolling-rotor compressor. 	

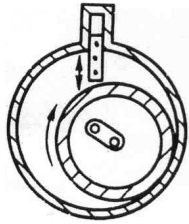
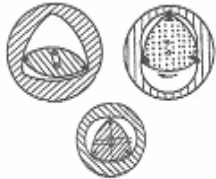
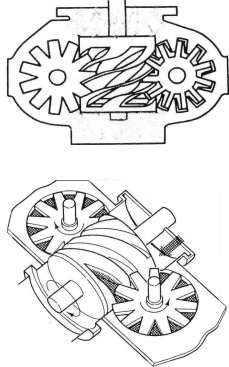
Class, term	Subclass	Definition		Illustration (example only)
Single-rotor compressor (continued)	Rolling-rotor compressor (continued)	Cylindrical-rolling-rotor compressor	A rolling-rotor compressor in which the rotor and casing are accomplished by cylindrical profiles, low- and high-pressure areas of the crescent-shaped compression chambers between the rotor and casing being separated by a gate plate constantly pressed to the rotor and sliding radially in a slot of the casing or swinging around the pivot on the casing.	
		Trochoidal rolling-rotor compressor (trochoidal compressor, Wankel compressor)	A rolling-rotor compressor in which two- or multi-apex rotor and casing are accomplished by conjugated trochoidal profiles and several variable-volume gas-admission and compression chambers are separated from each other by adjacent rotor apexes continuously sliding along the casing surface. NOTE 5 There can be profiles with apexes on the casing surface along which the rotor profile slides.	
	Single-screw compressor	A single-rotor compressor in which compression chambers constitute spaces between cylindrical casing, helical grooves on the screw rotor and lobes of two gate rotors mounted symmetrically and perpendicular on both sides of the screw rotor and meshing with it, said chambers being increased and then decreased by displacing from one end of the screw rotor to the other end due to rotation.		

2.5.2.3 Design classes of double-rotor compressors

Class, term	Definition and subclass	Illustration (example only)
Double-rotor compressor	A rotary compressor with two intermeshing lobed or toothed non-touching counter-rotating rotors driven in proper phase by external timing gears and rotating around the parallel axes in which the intermeshing zone separates low- and high-pressure areas, the volumes of the gas being trapped on low-pressure side between the lobes (teeth) and casing, transported through the non-meshing zone circumferentially along the cylindrical walls to the high-pressure area and compressed simultaneously by transportation or instantly by discharging.	



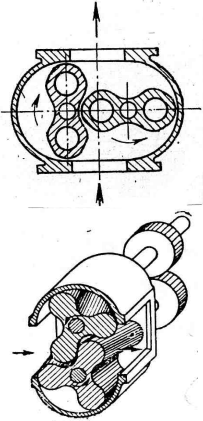
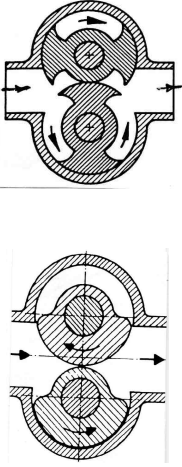
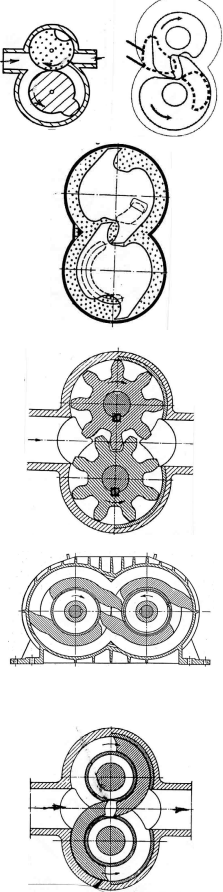

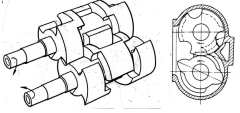
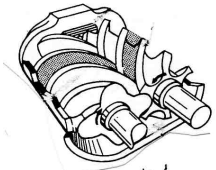
Class, term	Definition and subclass		Illustration (example only)
Double-rotor compressor (continued)	Internally meshing double-rotor compressor	<p>A double-rotor compressor with cylindrical casing in which intermeshing of two conjugated rotors takes place outside the straight line connecting the axes of their rotation.</p> <p>NOTE 1 In this type of compressor, one rotor is positioned inside the other.</p>	
	Externally meshing double-rotor compressor	<p>A double-rotor compressor with a figure eight-shaped casing in which intermeshing of two conjugated rotors takes place on the straight line connecting axes of their rotation.</p> <p>NOTE 2 Lobe-configuration subclasses are:</p> <ul style="list-style-type: none"> — straight-lobe compressor; — stepped-lobe compressor; — screw (helical-lobe) compressor. 	
	Straight-lobe double-rotor compressor	<p>An externally meshing double-rotor compressor in which the rotors have straight lobes parallel to their axes of rotation, profiles of the rotors being invariable along their length.</p> <p>NOTE 3 Only transportation of closed gas volumes from the low-pressure area to the high-pressure area (without internal compression) is performed as a rule in the working chambers of these compressors.</p> <p>After opening of the working chamber to the discharge pipe, the transported gas is mixed with the gas contained in the discharge pipe and then compressed jointly as a mixture by further movement of the lobes towards each other, this movement bringing to diminution of the combined mixture volume of the working chamber and the discharge pipe between the compressor and the check valve or compressed air user.</p> <p>NOTE 4 Lobe-profile subclasses are:</p> <ul style="list-style-type: none"> — Roots compressor (curved-profile double-rotor compressor); — special-profile double-rotor compressor. 	

Class, term	Definition and subclass			Illustration (example only)	
<p>Double-rotor compressor (continued)</p>	<p>Externally meshing double-rotor compressor (continued)</p>	<p>Straight-lobe double-rotor compressor (continued)</p>	<p>Roots compressor (blower), (Curved-profile straight-lobe double-rotor compressor)</p>	<p>A straight-lobe double-rotor compressor in which rotor lobes have circular, cycloid or other second-power-curved (or curvilinear) profiles.</p> <p>NOTE 5 The lobe-number subclasses are:</p> <ul style="list-style-type: none"> — two-lobe Roots compressor; — three-lobe Roots compressor; — multi-lobe Roots compressor. 	
			<p>Special-profile straight-lobe double-rotor compressor</p>	<p>A straight-lobe double-rotor compressor in which rotor lobes have special profiles.</p> <p>NOTE 6 There are many types of this subclass, named after the inventor, manufacturer or shape-resemblance ("Bicera", "Northey", "claw", etc.).</p> 	

Class, term	Definition and subclass		Illustration (example only)	
<p>Double-rotor compressor (continued)</p>	<p>Externally meshing double-rotor compressor (continued)</p>	<p>Stepped-lobe double-rotor compressor (continued)</p>	<p>An externally meshing double-rotor compressor in which rotors have two or more different-profile straight lobes along the length of the rotors, the lobes being parallel to their axis of rotation and having invariable profiles within each step.</p> <p>NOTE 7 In the stepped-lobe double-rotor compressor, internal compression of the gaseous medium can be performed.</p>	
		<p>Screw compressor</p>	<p>An externally meshing double-rotor compressor in which the rotors have helical lobes and grooves, volumes of said grooves being cyclically decreased and increased by engagement and disengagement of each groove-lobe pair, and their simultaneous shifting from low-pressure rotor end to the high-pressure end due to their synchronized rotation.</p> <p>NOTE 8 The force-transmitting subclasses are:</p> <ul style="list-style-type: none"> — oil (water)-flooded screw compressor; — oil-free screw compressor 	
		<p>Oil (water)-flooded screw compressor (direct-inter-meshing screw compressor)</p>	<p>A screw compressor in which the mechanical energy from the first rotor driven by the prime mover is transmitted to the second rotor essentially by direct contact of rotor lobes through the oil (water) film between them, the oil (water) being injected in the compression chamber and serving simultaneously as a lubricating, cooling and sealing medium.</p>	
		<p>Oil-free screw compressor (timing-gear- intermeshing screw compressor)</p>	<p>A screw compressor in which the mechanical energy from the first rotor driven by the prime mover is transmitted to the second rotor by the timing gear provided between two rotor shafts.</p>	

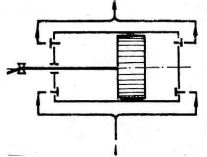
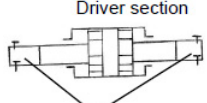

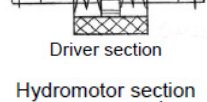
2.5.2.4 Design classes of reciprocating compressors

2.5.2.4.1 General

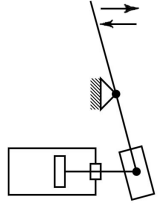
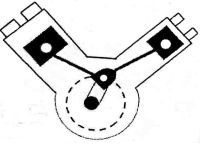

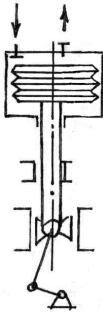
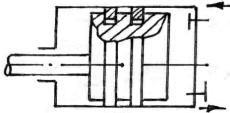
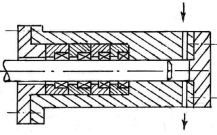
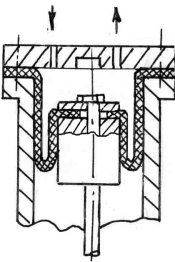
Class, term	Subclass	Definition	Illustration (example only)	
Reciprocating compressor	Piston compressor	A reciprocating compressor in which the moving member constitutes a piston reciprocating in a cylinder Subclasses of piston compressors by energy-supply methods to the piston:		
	Free-piston compressor	A piston compressor in which a built-in prime mover creating straight-forward driving forces is used these forces acting directly on the piston body or its reverse side.		
	Subclasses of free-piston compressors by driver types:			
	free-piston diesel-compressor	Individual definitions are not necessary because the wording of the terms characterizes sufficiently the basic design features of subclasses.	 <p>Driver section</p> <p>Compressor sections</p>  <p>Driver section</p> <p>Hydromotor section</p>  <p>Hydromotor section</p> <p>Compressor sections</p>  <p>Compressor section</p> <p>Expander (steam-engine) section</p>	
	free-piston electromagnetic compressor (free-piston linear-motor-compressor)			
	free-piston hydromotor-compressor			
free-piston expander-compressor				
free-piston steam-engine-compressor				

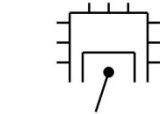
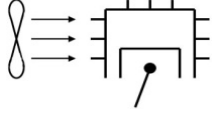
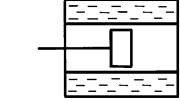
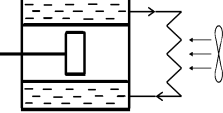
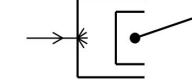

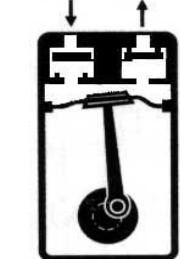
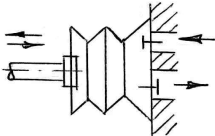
Class, term	Subclass	Definition		Illustration (example only)	
Reciprocating compressor (continued)	Piston compressor (continued)	Man-driven piston compressor	<p>A piston compressor in which the piston is driven by the muscle forces of the service personnel by means of auxiliary details or mechanisms (levers, hand wheels, rods, etc.).</p> <p>NOTE 1 Design subclasses are:</p> <ul style="list-style-type: none"> — pedal driven; — hand driven. <p>NOTE 2 Man-driven compressors are mostly used for emergency situations in transport-mounted installations, e.g. as ship-board emergency compressor.</p>		
		Shaft-driven piston compressor	<p>A piston compressor in which the mechanical energy from the driver is initially supplied to the rotating compressor shaft and transformed into the straightforward alternating movement of the compressor piston by means of auxiliary mechanical gearing.</p>		
Subclasses of shaft-driven piston compressors by auxiliary mechanical-gearing types:					
		1) crankshaft-driven	<p>Individual definitions are not necessary because the wording of the terms characterizes sufficiently the basic design features of subclasses.</p>	1)	
		2) link-mechanism driven		2)	
		3) swash-plate driven		5)	
		4) cam-and-spring driven		7)	
		5) slot-and-crank driven	3)	4)	7)
		6) rocking cylinder	6)		
		7) eccentric-driven	6)		

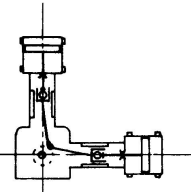
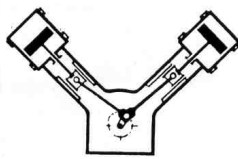
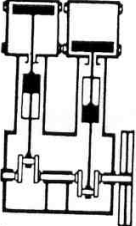
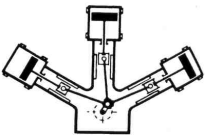
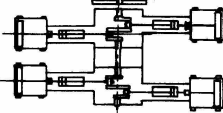

Class, term	Subclass	Definition	Illustration (example only)	
Reciprocating compressor (continued)	Piston compressor (continued)	Subclasses of piston compressors by compression-chamber sealing methods:		
		Labyrinth-piston compressor	<p>A piston compressor in which the barrier to the compressed-gas leakages from the cylinder through the gap between the piston and cylinder wall is obtained by labyrinth system representing a plurality of successive constrictions and expansions formed by grooves on the piston or cylinder surfaces, this system ensuring the loss of the flow energy along the gap because of multiple throttling process.</p> <p>NOTE 3 The piston rod in the labyrinth piston compressor is guided in an additional bearing besides the crosshead to ensure contactless movement of the piston and piston rod in the cylinder.</p>	
		Piston-ring compressor	<p>A crosshead-type piston compressor in which the barrier to the compressed-gas leakages from the cylinder through the gap between the piston and cylinder wall is achieved by means of elastic low-friction sealing rings placed in the circumferential piston grooves and pressed to the cylinder wall basically by their natural elasticity and overlapping the gap between the piston and cylinder wall.</p> <p>NOTE 4 In some designs, the piston ring can represent a piston cup or collar ring.</p>	
		Plunger compressor	<p>A crosshead-type piston compressor in which the barrier to the compressed-gas leakages from the cylinder through the gap between the piston and cylinder is obtained by means of packing surrounding the plunger-type piston in which segments of low-friction composed sealing rings are pressed to the smooth piston surface by ring-type springs these segments overlapping the gap between the plunger and cylinder wall.</p>	
Rolling-diaphragm compressor	<p>A piston compressor in which the barrier to the compressed-gas leakages from the cylinder through the gap between the piston and cylinder is obtained by means of a flexible impermeable cylindrical diaphragm with two end collars clamped by one end to the cylinder wall and by other end to the piston body and rolling in the gap between the piston and cylinder wall and hermetically isolating the cylinder inner volume.</p>			

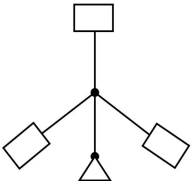
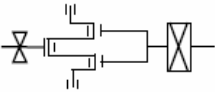
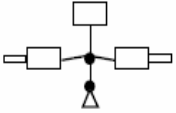
Class, term	Subclass	Definition		Illustration (example only)
Reciprocating compressor (continued)	Piston compressor (continued)	Subclasses of piston compressors by compression-chamber cooling methods		
		Non-cooled	Individual definitions are not necessary because the wording of the terms characterizes sufficiently the basic design features of subclasses.	
		Air-cooled		
		Water-cooled		
		Water-air cooled (closed-loop cooled)		
		Water-injection cooled		
Diaphragm compressor (membrane compressor)		<p>A reciprocating compressor in which the moving member constitutes a peripherally clamped and sealed flexible membrane or diaphragm in essentially concavo-concave compression chamber.</p> <p>NOTE 5 The basic diaphragm design subclasses are:</p> <ul style="list-style-type: none"> — hydraulically driven (flexible-centre) diaphragm compressor; — mechanically driven (rigid-centre) diaphragm compressor. 		
		Subclasses of diaphragm compressors by energy-supply methods to the diaphragm.		
		Hydraulically driven (flexible-centre) diaphragm compressor	A diaphragm compressor in which the reciprocating motion of the diaphragm is performed by cyclical supply of the non-compressible pressurized liquid on its reverse side and its successive withdrawal by means of a built-in piston pump.	
		Mechanically driven (rigid-centre) diaphragm compressor	A diaphragm compressor in which the reciprocating motion of the diaphragm is performed by crank mechanism or other mechanical gearing, its connecting rod or other driving element being secured rigidly to the diaphragm centre by means of supporting washers.	
Bellows-type compressor		A reciprocating compressor in which the moving member constitutes one of two opposite solid walls connected by flexible bellows-type folding walls, volumes of the compression chamber being decreased and increased by cyclical movement of one solid wall backwards and forwards.		

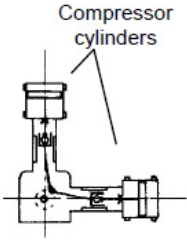
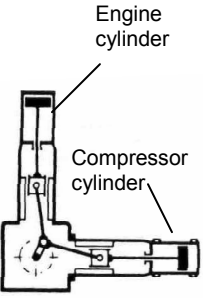
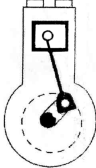
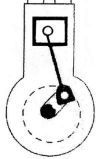
2.5.2.4.2 Design classes of crankshaft-driven piston compressors

Class, term	Subclass and definition	Illustration (example only)		
Crankshaft-driven piston compressor	Subclasses of crankshaft-driven piston compressors by crank-mechanism configuration types:			
	a) vertical	Individual definitions are not necessary because the wording of the terms characterizes sufficiently the basic design features of subclasses.	a)	
	b) L-type			
	c) V-type			
	d) W-type			
	e) horizontal-opposed (boxer type)	e 1) displaced-row (torque-generating) boxers	b)  c) 	
		e 2) in-line-row (coaxial-row, torqueless) boxers	d)  e 1) 	f) 
	f) horizontal in-line type			h) 
	g) T-type		e 2) 	
	h) star-type		g) 	

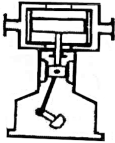
Class, term	Subclass and definition		Illustration (example only)
Crankshaft-driven piston compressor (continued)	Subclasses of crankshaft-driven piston compressors by compressor and driver crank mechanism integration grades:		
	Separable crankshaft-driven engine-compressor	A crankshaft-driven piston compressor with an individual crank mechanism which can be connected to the power-output shaft of any prime-mover through an external coupling.	
Crankshaft-driven piston engine-compressor	Integral crankshaft-driven engine-compressor A crankshaft-driving piston compressor integral with a driving reciprocating internal-combustion engine and having common crankshaft and crankcase both for compressor and engine crank mechanisms.		
Subclasses of crankshaft-driven piston compressors by piston-driven methods:			
Trunk type (single-acting) crankshaft-driven piston compressor	A crankshaft-driven piston compressor in which the connecting rod of the crankshaft mechanism is connected directly to one side of the piston and only its other side is used for the compression process in the cylinder.		
	Subclasses of trunk-type crankshaft-driven piston compressors by piston/connecting rod conjunction methods:		
	Trunk-type crankshaft-driven articulated-piston compressor	A trunk-piston compressor in which the piston is articulated to the connecting rod by means of radial bearing.	
	Trunk-type crankshaft-driven rocking-piston compressor	A trunk-piston compressor in which the piston is rigidly secured to the connecting rod and performs simultaneous angular rocking motions by reciprocating in the cylinder.	

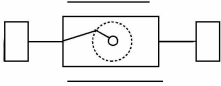
Class, term	Subclass and definition		Illustration (example only)
Crankshaft-driven piston compressor (continued)	Crosshead-type (double-acting) crankshaft-driven piston compressor		
	Subclasses of crosshead-type crankshaft-driven piston compressors by crosshead functions:		
	Single-acting-crosshead-type crankshaft-driven piston compressor	A crosshead-type crankshaft-driven piston compressor in which only one piston rod can be connected to the crosshead body.	
Double-acting (yoke-type) crosshead type crankshaft-driven piston compressor	A crosshead-type crankshaft-driven piston compressor in which the crosshead has a yoke-type frame externally embracing the crank mechanism and is capable of driving simultaneously two opposite piston rods or plungers.		

3 Functional classes of the compressor equipment, terms and definitions

3.1 General

Functional classes define the level/extent of basic structural and functional component parts included in compressor equipment regardless of specific design features and should be used for technical and economical comparison and evaluation of different compressor alternatives. Basic technical and economical parameters of compressor equipment: specific power consumption, reliability factors, mass, dimensions, prices, etc. of compressor options should be compared by identical extent of functional components of compressor equipment regardless of design and integration features of components.

Basic functional classes define the amount/extent of component parts included for the typical case of the gradual increasing of functional items when supplied, from the minimum to the maximum amount of component parts, according to the following equipment sequence chain: mechanical compressor – motion-converting mechanism – speed-adjusting gear – driver – auxiliary gas-processing equipment – aftercooler – packaging base – dryer – receiver - enclosure.

Derivative functional classes define any other amount of component parts using all other random combinations of components due to omitting any part(s) according to specific contractual supply conditions.

Derivative functional classes are presented in matrix form as a cross-combination of driver-compressor functional subclasses with compressor supply variants.

If other new functional parts should be taken into account for differentiation of specific compressor equipment dependent on requirements of particular supply or operation conditions, deviations from the combinations presented should be considered additional lower subclasses and specified by introduction of particular attributes reflecting new properties and components or by listing new additional functions.



The shortened terms (e.g. “compressor”, “compressor plant” or their abbreviated terms) may be used in the descriptive technical documentation after the first full designation of the functional classes and special notice about it, if there is no danger of their multi-semantic interpretation.

There can be some freedom in the choice of sequence of words in composite terms and their coupling forms as long as basic key words and euphony are maintained (e.g. the terms “packaged aftercooled compressor plant” and “aftercooled packaged compressor plant” are considered equivalent).

Dryers and receivers are included in the aggregated compressor equipment only through their factory assembly and mounting on the common baseplate or by using the receiver for mounting the compressor equipment in the extent of supply. For separate supply of dryers and receivers intended for stand-alone mounting and operation, they should be considered independent individual items of gas-processing apparatuses.

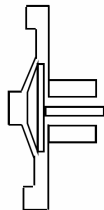
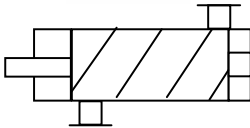
3.2 Basic functional classes of compressor machines

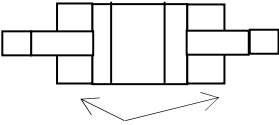
Number	Term	Definition	Illustration (example only)
1.	Compressor equipment (generic term)	Basic or auxiliary structural elements of the compressor installation: machines, apparatuses, piping and valving, control and instrumentation, their parts or combinations participating in admission, compression, processing and delivery of the gaseous medium, taken totally or partly, in general, regardless of design, extent or quantity.	
2.	Mechanical compressor	<p>A compressor machine constituting essentially one or several working members movable in compression chambers and common built-in mechanism for conversion of external energy supply motion of the driver to the required working member motion, and being operable by supply of external mechanical energy from the power output shaft, or motion rod or piston of the driver or speed-adjusting driving gear.</p> <p>NOTE 1 The mechanical compressor contains necessary auxiliary devices for performing the gas compression process in the working chambers: applicable gas inlet and outlet valves, gas flow paths, seals, lubrication system, capacity control means, measuring instruments etc., but it does not contain driver, speed-adjusting gear, gas processing apparatuses and piping or compressor equipment packaging and mounting facilities and enclosures.</p>	<p>Motion converting mechanism</p> 
		<p>NOTE 2 By the same character of motions of driver power-output shaft (rod, or piston) and compressor working members (e.g. both are rotating or both are reciprocating) the mechanical compressor does not contain the motion conversion mechanism (e.g. as in axial, centrifugal, rotary compressors).</p>	<p>Centrifugal compressor</p>  <p>Screw compressor</p> 

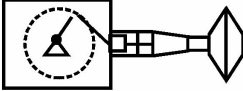
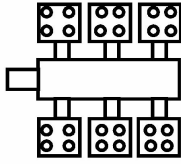
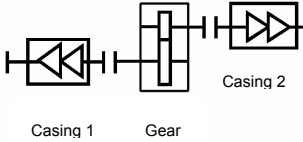
<p>2. (continued)</p>	<p>Mechanical compressor (continued)</p>	<p>NOTE 3 In some compressor design types, the mechanical compressor can be integrated with the driver in a single non-separable unit if the motions of the driver output shaft (rod or piston) and the compressor working members are of the same speed and character (e.g. as in integral engine-compressors or in free-piston compressors).</p>	<p>Driver section</p>  <p>Mechanical compressor sections</p>  <p>Driver section Compressor section</p>
		<p>NOTE 4 In some design types, the mechanical compressor can use several steps for converting externally applied mechanical energy.</p> <p>EXAMPLE 1 The mechanical centrifugal compressor has two energy conversion stages according to the scheme: mechanical energy of the rotating shaft → kinetic energy of the gas stream → potential energy of the gas pressure.</p> <p>EXAMPLE 2 The mechanical diaphragm compressor can have four energy conversion stages: mechanical energy of the rotating shaft → mechanical energy of reciprocating piston → potential energy of the oil pressure → mechanical energy of the reciprocating diaphragm and potential energy of the gas pressure.</p>	 <p>Diaphragm compressor</p>
		<p>NOTE 5 By compressing gases to high pressures, the mechanical compressor can be used as a multistage or multi-casing compressor train containing several cylinders driven by common power-input shaft and connected together by coupling, speed-adjusting gear or common motion-converting mechanism.</p> <p>NOTE 6 Auxiliary mechanisms for conversion of rotating motion into reciprocating, orbital, angular- swinging, flexible-pipe-peristaltic motions are mostly used in compressors.</p> <p>NOTE 7 Large multistage mechanical compressors can be supplied as two or more separate parts: as mechanical compression devices (e.g. diaphragm or piston/cylinder blocks) and motion-converting mechanism (“frame”) to be assembled into the complete mechanical compressor at the place of operation.</p>	<p>Multistage mechanical compressor</p>  <p>Stage 1 Stage 2 Stage 3</p> <p>Multi-casing mechanical compressor</p>  <p>Casing 1 Gear Casing 2</p>

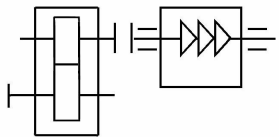
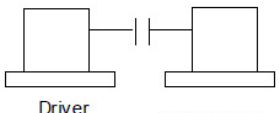
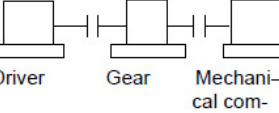
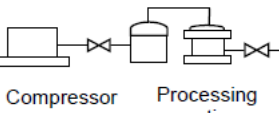
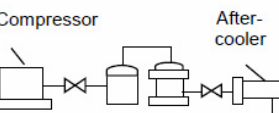
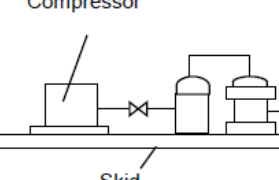
3.	Geared mechanical compressor	A mechanical compressor with a speed-adjusting gear for matching driver power-output and compressor power input shaft (rod, piston) motions.	 <p style="text-align: center;">Gear Mechanical compressor</p>
4.	Driver-compressor (generic term; subclasses – according to energy forms used and driver types)	<p>A mechanical compressor with a driver, including its auxiliary systems (lubrication, cooling etc.) and connected directly by coupling.</p> <p>NOTE 8 A contracted term “driver-compressor” is used instead of the formal “driver-mechanical compressor” because all drivers for compressor machines produce mechanical energy so the word “mechanical” is superfluous.</p> <p>NOTE 9 For specific compressor equipment with known driver types, the generic term “driver-compressor” can be replaced by subclass terminology according to the kind of available external primary energy (motor-compressor, engine-compressor, etc.).</p>	 <p style="text-align: center;">Driver Mechanical compressor</p>
5.	Geared driver-compressor	A mechanical compressor with a driver and speed-adjusting gear connected by a coupling.	 <p style="text-align: center;">Driver Gear Mechanical compressor</p>
6.	Compressor plant	<p>A compressor (mechanical compressor, driver-compressor, etc.) furnished with gas-admission, processing and delivery facilities, pre- and post-compressor and interstage gas piping, instrumentation, control, automation and safeguarding means for ensuring safe compression of the gaseous medium up to the required end pressure both by single-stage and multistage compression.</p> <p>NOTE 10 The compressor plant can include apparatuses, vessels, pipes and fittings for performing following gas-processing operations: filtration, water and condensate separation, gas transportation, pre-compressor and interstage cooling, oil separation, attenuation of gas pulsations, etc.</p> <p>NOTE 11 The term “compressor plant” does not include driver system (as non-processing gas directly) and additional or optional equipment supplied for specific operating or mounting conditions such as dryer, aftercooler, skid, receiver, as well as silencing, weather protecting or sealing enclosures. These components can be used as single common units for several compressors or supplied as separate process equipment. The presence of additional processing equipment can be expressed by application of additional terms such as “aftercooled” or “packaged” or “enclosed plant” and “motor-compressor plant/dryer”.</p>	 <p style="text-align: center;">Compressor Processing section</p>
7.	Aftercooled compressor plant	A compressor plant furnished with aftercooler.	 <p style="text-align: center;">Compressor After-cooler</p> <p style="text-align: center;">Compressor plant</p>
8.	Packaged compressor equipment (compressor, compressor plant)	Compressor equipment (plant) mounted in the extent of supply on the steel skid, receiver, coolers, etc. and supplied as a self-contained, factory-assembled, fully piped and wired unit.	 <p style="text-align: center;">Compressor</p> <p style="text-align: center;">Skid</p>

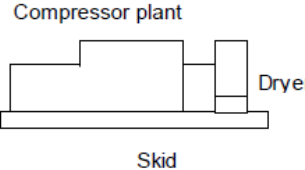
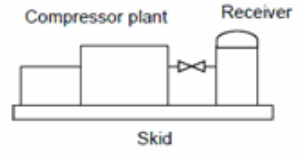
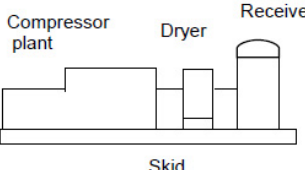
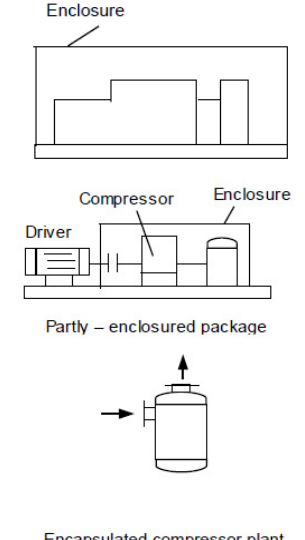
9.	Packaged compressor plant/dryer	A compressor plant and compressed-gas dryer supplied as a single package on the common base (skid, etc.)	 <p>Compressor plant Dryer Skid</p>
10.	Packaged compressor plant/receiver	A compressor plant and compressed-gas receiver supplied as a single package on the common base (skid, etc.)	 <p>Compressor plant Receiver Skid</p>
11.	Packaged compressor plant/dryer/receiver	Compressor plant, compressed air dryer and receiver supplied as a single package on the common base (skid, etc.)	 <p>Compressor plant Dryer Receiver Skid</p>
12.	Enclosed compressor equipment (compressor, compressor plant)	Packaged compressor equipment with soundproof, or weather-protected or hermetically sealed (encapsulated) partial or full-volume enclosure.	 <p>Enclosure Compressor Enclosure Driver Partly – enclosed package Encapsulated compressor plant</p>

3.3 Formation principles of derivative functional classes for compressor machines

NOTE For visual demonstration of formation principles of **derivative classes**, key attributes of compressor **plant** functional classes in vertical columns are marked in **bold**, and key attributes of compressor and driver-compressor functional classes in horizontal lines are stressed by underlining.

Functional classes of compressors and driver-compressors	Basic functional structural component parts of the compressor equipment added successively to the previous extent of supply on the left-hand side of each column					Enclosure
	Gas admission, interstage cooling, separation, dampening, piping, control, instrumentation, etc.	Aftercooler: (+) - included, (-) – not included	Mounting skid, slide etc. for factory assembly and packaging	Compressed-gas dryer: (+) - included, (-) – not included	Compressed-gas receiver	
Compressor (Generic term)	Compressor plant					
	Basic functional classes of the compressor plants regardless of the design classes and subclasses of compressors or driver-compressors					
	(+) Aftercooled compressor plant	Packaged aftercooled compressor plant	(+) Packaged aftercooled compressor plant/ dryer	Packaged aftercooled compressor plant/ receiver	Packaged aftercooled compressor plant/ receiver	Packaged aftercooled compressor plant/ receiver
	(-) (see the previous column on the left)	Packaged compressor plant	(-) (See the previous column on the left)	Packaged aftercooled compressor plant/ receiver	Packaged aftercooled compressor plant/ receiver	Packaged aftercooled compressor plant/ receiver
			(+) Packaged compressor plant/ dryer	Packaged compressor plant/ receiver	Packaged compressor plant/ receiver	Packaged enclosed compressor plant/dryer/receiver
			(-) (see the previous column on the left)	Packaged compressor plant/ receiver	Packaged compressor plant/ receiver	Packaged enclosed compressor plant/receiver

Functional classes of compressors and driver-compressors		Basic functional structural component parts of the compressor equipment added successively to the previous extent of supply on the left-hand side of each column					
		Gas admission, interstage cooling, separation, dampening, piping, control, instrumentation etc.	Aftercooler: (+) - included, (-) – not included	Mounting skid, slide, etc. for factory assembly and packaging	Compressed-gas dryer: (+) - included, (-) – not included	Compressed-gas receiver	Enclosure
Mechanical compressor	Mechanical compressor plant	Derivative functional classes of mechanical compressor plants					
		(+)	Aftercooled <u>mechanical</u> compressor plant	Packaged aftercooled <u>mechanical</u> compressor plant	Packaged aftercooled <u>mechanical</u> compressor plant/ dryer	Packaged aftercooled <u>mechanical</u> compressor plant/ receiver	Packaged aftercooled <u>mechanical</u> compressor plant/ dryer/receiver
		(-)	(see the previous column on the left)	Packaged <u>mechanical</u> compressor plant	Packaged <u>mechanical</u> compressor plant/ dryer	Packaged <u>mechanical</u> compressor plant/ receiver	Packaged <u>mechanical</u> compressor plant/ dryer/receiver
		(+)	(see the previous column on the left)	Packaged <u>mechanical</u> compressor plant	Packaged <u>mechanical</u> compressor plant/ dryer	Packaged <u>mechanical</u> compressor plant/ receiver	Packaged <u>mechanical</u> compressor plant/ dryer/receiver

Functional classes of compressors and driver-compressors		Basic functional structural component parts of the compressor equipment added successively to the previous extent of supply on the left-hand side of each column					
	Gas admission, interstage cooling, separation, dampening, piping, control, instrumentation, etc.	Aftercooler: (+) - included, (-) – not included	Mounting skid, slide etc. for factory assembly and packaging	Compressed-gas dryer: (+) - included, (-) – not included	Compressed-gas receiver	Enclosure	
<u>Gear</u> ed <u>mechanical</u> compressor	G <u>ear</u> ed <u>mechanical</u> compressor <u>plant</u>	(+)	Derivative functional classes of <u>gear</u> ed <u>mechanical</u> compressor plants				
		(+)	<u>A</u> fter <u>cooled</u> <u>gear</u> ed <u>mechanical</u> compressor <u>plant</u>	<u>G</u> ear <u>ed</u> <u>mechanical</u> aftercooled <u>gear</u> ed <u>mechanical</u> compressor <u>plant</u> / <u>dryer</u>	Packaged aftercooled <u>gear</u> ed <u>mechanical</u> compressor <u>plant</u> / <u>dryer</u> / <u>receiver</u>	Packaged aftercooled <u>gear</u> ed <u>mechanical</u> compressor <u>plant</u> / <u>dryer</u> / <u>receiver</u>	Packaged aftercooled <u>gear</u> ed <u>mechanical</u> compressor <u>plant</u> / <u>dryer</u> / <u>receiver</u>
		(-)	(see the previous column on the left)	<u>P</u> ack <u>aged</u> <u>gear</u> ed <u>mechanical</u> compressor <u>plant</u>	(-) (see the previous column on the left)	Packaged aftercooled <u>gear</u> ed <u>mechanical</u> compressor <u>plant</u> / <u>receiver</u>	Packaged aftercooled <u>gear</u> ed <u>mechanical</u> compressor <u>plant</u> / <u>receiver</u>
		(-)	(see the previous column on the left)	<u>P</u> ack <u>aged</u> <u>gear</u> ed <u>mechanical</u> compressor <u>plant</u>	(+) Packaged <u>gear</u> ed <u>mechanical</u> compressor <u>plant</u> / <u>dryer</u>	Packaged <u>gear</u> ed <u>mechanical</u> compressor <u>plant</u> / <u>dryer</u> / <u>receiver</u>	Packaged <u>gear</u> ed <u>mechanical</u> compressor <u>plant</u> / <u>dryer</u> / <u>receiver</u>
				(-) (see the previous column on the left)	Packaged <u>gear</u> ed <u>mechanical</u> compressor <u>plant</u> / <u>receiver</u>	Packaged <u>gear</u> ed <u>mechanical</u> compressor <u>plant</u> / <u>receiver</u>	

Functional classes of compressors and driver-compressors		Basic functional structural component parts of the compressor equipment added successively to the previous extent of supply on the left-hand side of each column				
	Gas admission, interstage cooling, separation, dampening, piping, control, instrumentation, etc.	Aftercooler: (+) - included, (-) – not included	Mounting skid, slide, etc. for factory assembly and packaging	Compressed-gas dryer: (+) - included, (-) – not included	Compressed-gas receiver	Enclosure
Driver-compressor	<u>Driver-compressor plant</u>	Derivative functional classes of <u>driver-compressor plants</u>				
		(+)	<u>Aftercooled driver-compressor plant</u>	<u>Packaged aftercooled driver-compressor plant</u>	Packaged aftercooled <u>driver-compressor plant/dryer</u>	Packaged aftercooled <u>driver-compressor plant/dryer/receiver</u>
		(-)	(See the previous column on the left)	<u>Packaged driver-compressor plant</u>	(-) (see the previous column on the left)	Packaged aftercooled <u>driver-compressor plant/receiver</u>
		(+)	<u>Packaged driver-compressor plant</u>	Packaged <u>driver-compressor plant/dryer</u>	Packaged <u>driver-compressor plant/dryer/receiver</u>	Packaged <u>enclosed driver-compressor plant/dryer/receiver</u>
		(-)	(See the previous column on the left)	(-) (see the previous column on the left)	Packaged <u>driver-compressor plant/receiver</u>	Packaged <u>enclosed driver-compressor plant/receiver</u>

Functional classes of driver-compressors		Basic functional structural component parts of the compressor equipment added successively to the previous extent of supply on the left-hand side of each column				
	Gas admission, interstage cooling, separation, dampening, piping, control, instrumentation, etc.	Aftercooler: (+) - included, (-) – not included	Mounting skid, slide etc. for factory assembly and packaging	Compressed-gas dryer: (+) - included, (-) – not included	Compressed-gas receiver	Enclosure
Geared driver-compressor	Geared driver-compressor plant	Derivative functional classes of geared driver – compressor plants				
		(+)	Geared aftercooled driver-compressor plant	Geared aftercooled packaged driver-compressor plant	Geared aftercooled packaged driver-compressor plant/dryer/receiver	Geared aftercooled packaged driver-compressor plant/dryer/receiver
		(-)	(see the previous column on the left)	Geared packaged driver-compressor plant	Geared packaged driver-compressor plant/dryer	Geared packaged driver-compressor plant/dryer/receiver
		(-)	(see the previous column on the left)	(see the previous column on the left)	Geared aftercooled packaged driver-compressor plant/receiver	Geared aftercooled packaged driver-compressor plant/receiver

3.4 Functional classes of compressor apparatuses

NOTE For specific types of compressor apparatuses, in this table, the generic term “compressor plant” is replaced by concrete terms identifying the corresponding specific design subclass, e.g. “thermo compressor plant”, “adsorption compressor plant”, “ejector plant”.

Functional parts of compressor plants added successively to the previous extent of supply given on the left-hand side of each column							
Compressor apparatus: compression chamber(s) with integrated energy supply/conversion means for activating compression process; auxiliary devices (inlet and outlet valves, etc.)	Gas admission, processing, delivery facilities and piping and control and instrumentation necessary for safe operation of the compressor equipment	Aftercooler: (+) - included, (-) – not included	Skid, baseplate etc. for factory assembly and packaging	Dryer (+) - included, (-) – not included	Receiver	Enclosure	
Ejector	Ejector body with inlet nozzles for auxiliary pressurized fluid and gas to be compressed and outlet diffuser						
Thermo-compressor	Thermocompression chamber with integrated heaters and coolers	(+) Aftercooled compressor plant (e.g. aftercooled thermocompressor plant)	Packaged aftercooled compressor plant (e.g. packaged aftercooled thermocompressor plant)	(+) Packaged aftercooled compressor plant/dryer (e.g. packaged aftercooled thermocompressor plant/dryer)	Packaged aftercooled compressor plant/dryer/receiver	Packaged aftercooled enclosed compressor plant/dryer/receiver	
Adsorption compressor	Compression chamber filled with adsorbent (e.g. metal hydride cassettes) and integrated with heaters and coolers			(-) (see the previous column on the left)	Packaged aftercooled compressor plant/receiver	Packaged aftercooled enclosed compressor plant/receiver	
General functional classes of compressor apparatuses regardless of their design classes							
	Compressor plant (e.g. thermocompressor plant)						

Functional parts of compressor plants added successively to the previous extent of supply given on the left-hand side of each column						
Compressor apparatus: compression chamber(s) with integrated energy supply/conversion means for activating compression process; auxiliary devices (inlet and outlet valves, etc.)	Gas admission, processing, delivery facilities and piping and control and instrumentation necessary for safe operation of the compressor equipment	Aftercooler: (+) - included, (-) - not included	Skid, baseplate etc. for factory assembly and packaging	Dryer (+) - included, (-) - not included	Receiver	Enclosure
Acoustical compressor	Compressor plant (e.g. thermocompressor plant)	(-) (see the previous column on the left)	Packaged compressor plant (e.g. packaged thermocompressor plant)	(+) Packaged compressor plant/dryer (e.g. packaged thermocompressor plant/dryer)	Packaged compressor plant/dryer/receiver	Packaged enclosed compressor plant/dryer/receiver
Pressure-shock compressor (Pressure exchanger)	Compressor plant (e.g. thermocompressor plant)	(-) (see the previous column on the left)	Packaged compressor plant (e.g. packaged thermocompressor plant)	(+) Packaged compressor plant/dryer (e.g. packaged thermocompressor plant/dryer)	Packaged compressor plant/dryer/receiver	Packaged enclosed compressor plant/dryer/receiver
Liquid-column compressor	Compressor plant (e.g. thermocompressor plant)	(-) (see the previous column on the left)	Packaged compressor plant (e.g. packaged thermocompressor plant)	(-) (see the previous column on the left)	Packaged compressor plant/receiver	Packaged enclosed compressor plant/receiver

4 Design classes of the aggregated compressor equipment, terms and definitions

4.1 General

The classification of aggregated compressor equipment incorporates a variety of design features of auxiliary structural components of complete compressor installations as well as diversity in their combination principles with other components (separable, integral, built-in, etc.).

The typical functional classification chain (see 3.1) is accepted as a base for the development of the general classification system of the aggregated compressors. The general structure of the system with the classification criteria of different grades of functional classes is presented in Figure 2.

Classification trees for driver-compressors, compressor plants and packaged compressor plants are presented in Figures 3, 4 and 5, respectively

.....

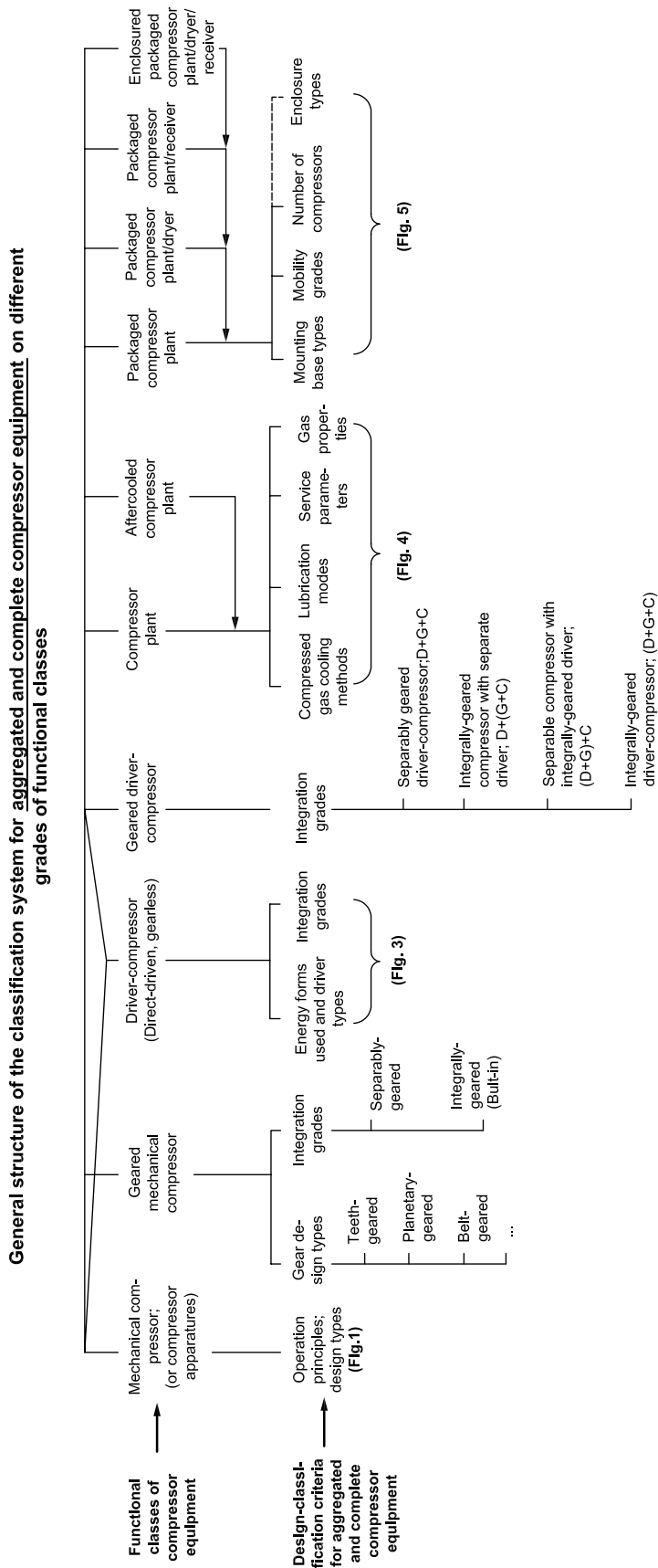

Figure 2 — General structure of the classification system of aggregated and complete compressor equipment of different grades of functional classes

Design & service-duty classes of compressor plants

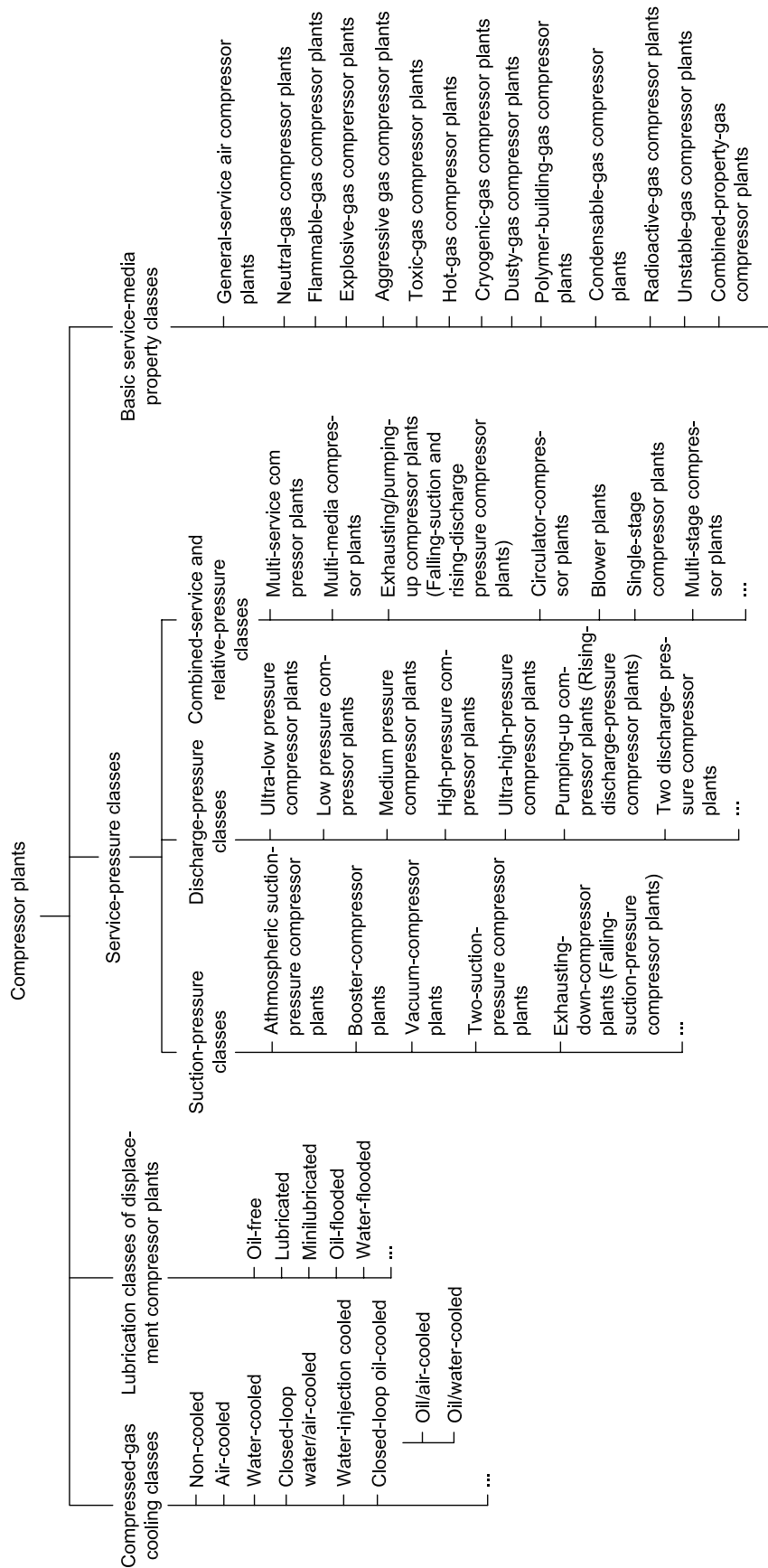

Figure 4 — Design and service-duty classes of compressor plants

Design classes of packaged compressor plants

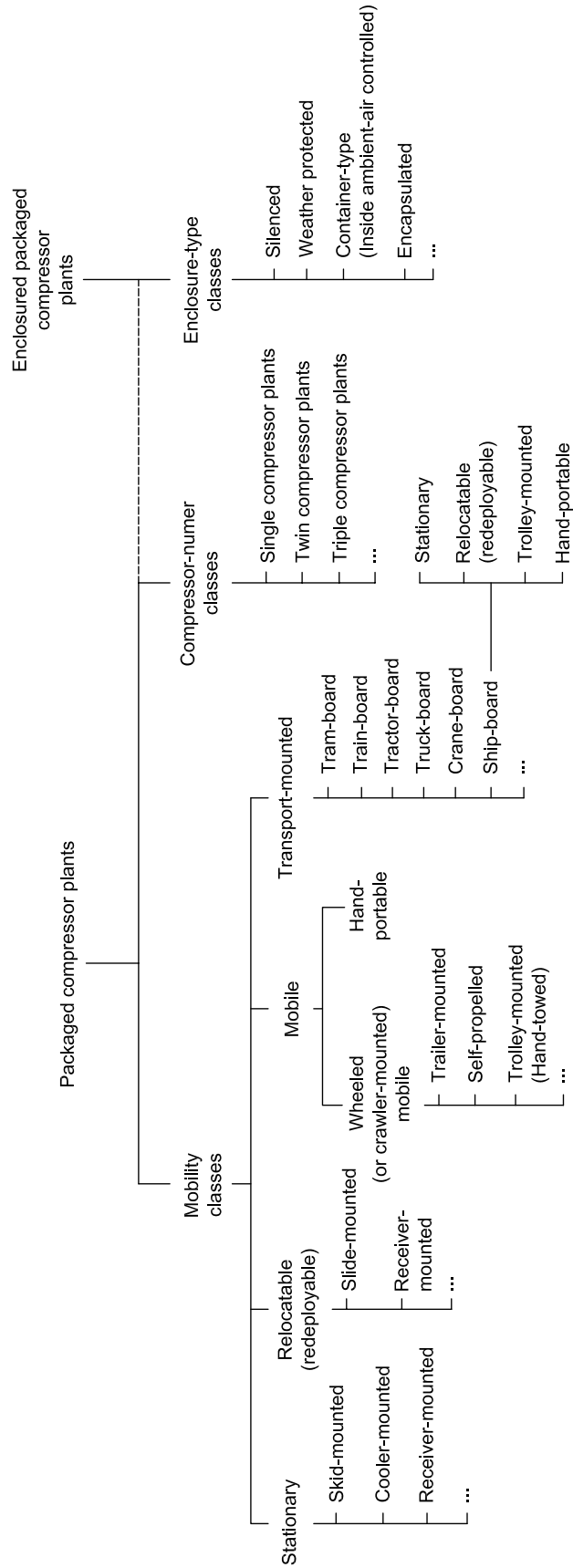
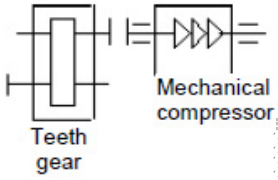
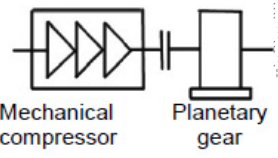
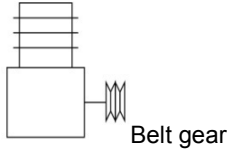
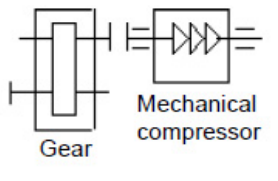
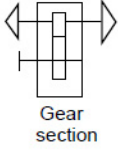
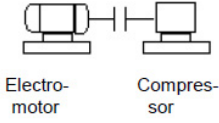
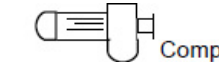
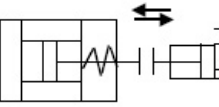
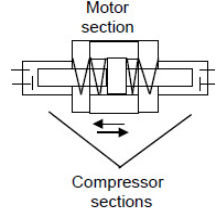
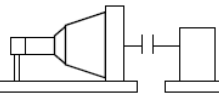
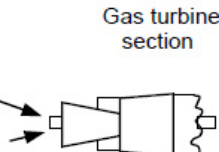

Figure 5 — Design classes of packaged compressor plants

4.2 Design classes of geared mechanical compressors

Class, term	Subclass and definition	Illustration (example only)	
Geared mechanical compressor	Subclasses by gear-design type		
	Teeth-gear mechanical compressor	Individual definitions are not necessary because the wording of the terms characterizes sufficiently the basic design features of subclasses.	 <p>Teeth gear Mechanical compressor</p>
	Planetary-gear mechanical compressor		 <p>Mechanical compressor Planetary gear</p>
	Belt-gear mechanical compressor		<p>Mechanical compressor</p>  <p>Belt gear</p>
	Subclasses by integration grades		
	Separable-gear mechanical compressor	A geared mechanical compressor in which gear wheel(s) and compressor working member(s) (or its motion-converting mechanism) have separate shafts connected by a coupling for force- or torque transmitting.	 <p>Gear Mechanical compressor</p>
	Integrally-gear mechanical compressor	A geared mechanical compressor with a built-in speed-adjusting gear in which the working member(s) and gear wheel(s) have a common force- or torque transmitting one-piece or composed shaft (or shafts).	<p>Compressor section</p>  <p>Gear section</p>

4.3 Design classes of driver-compressors

Class, term	Subclass and definition		Illustration (example only)	
Electrically-powered driver-compressor (generic term)	A driver-compressor in which electrically powered prime mover converting the electric energy into the mechanical energy is used for actuating the mechanical compressor.			
	Electromotor-compressor (motor-compressor)	An electrically powered driver-compressor in which an electromotor with rotating output shaft is used.	 <p>Electro-motor Compressor</p>	
		Separable (electro)-motor-compressor		An electromotor-compressor in which the power-output shaft of the electromotor drives the compressor shaft by means of a coupling.
		Integral (electro) motor-compressor	An electromotor-compressor in which the electromotor and the mechanical compressor have a common one-piece or composed torque-transmitting shaft.	 <p>Electro-motor section Compressor section</p>
	Free-piston electromagnetic compressor (Free-piston linear-motor compressor)	An electrically powered shaftless driver-compressor in which an electromagnetic motor with reciprocating power-output shaft or rod is used		
		Separable free-piston electromagnetic compressor	A free-piston electromagnetic compressor in which the reciprocating power-output shaft or rod of the motor drives the compressor shaft by means of a coupling.	 <p>Electro-magnetic motor Compressor</p>
Integral free-piston electromagnetic compressor			A free-piston electromagnetic compressor with built-in motor in which driving forces of the motor act directly on the piston body.	 <p>Motor section Compressor sections</p>
Fuel-heat-energy powered driver-compressor (generic term)	A driver-compressor in which a heat engine is used for transformation of the chemical energy of the fuel into the mechanical energy.			
	Gas-turbine compressor	A mechanical compressor with a gas turbine as a driver.		
		Separable gas-turbine compressor	A gas-turbine compressor in which power-output shaft of the turbine drives the compressor shaft through a coupling.	 <p>Gas turbine Compressor</p>
	Integral gas-turbine compressor		A gas-turbine compressor in which turbine and compressor have a common torque-transmitting one-piece or composed shaft.	 <p>Gas turbine section Compressor section</p>

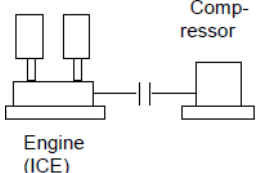
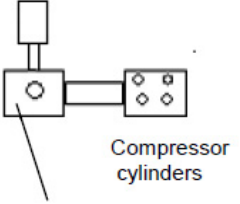
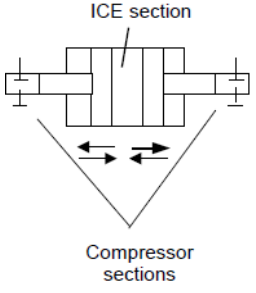
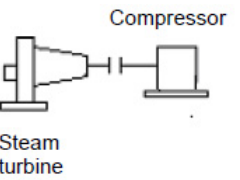
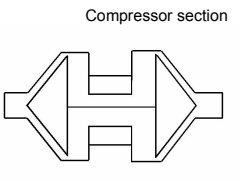
Class, term	Subclass and definition		Illustration (example only)	
Fuel-heat-energy powered driver-compressor (generic term) (continued)	Engine-compressor (ICE-compressor), reciprocating engine-compressor	A mechanical compressor with a reciprocating internal-combustion engine as a driver.		
		Separable engine-compressor	A mechanical compressor and a reciprocating internal-combustion engine as a driver having separate power-output shaft and connected by a coupling	 <p>Engine (ICE)</p>
		Integral engine-compressor	A mechanical piston compressor and an integrated reciprocating internal combustion engine (ICE) as a driver having the common crankshaft and crankcase for both crankshaft mechanisms. NOTE 1 Subclasses are: — integral gas-engine-compressor; — integral diesel-compressor.	 <p>ICE cylinders</p> <p>Common crank mechanism</p> <p>Compressor cylinders</p>
Free-piston engine-compressor	A shaftless mechanical reciprocating compressor and a built-in reciprocating ICE as a driver whose driving forces act directly on the reverse side of the compressor pistons. NOTE 2 Subclasses are: — free-piston gas-engine-compressor; — free-piston diesel-compressor.	 <p>ICE section</p> <p>Compressor sections</p>		
Fluid-pressure-energy powered driver-compressor (generic term)	A driver-compressor in which an expander machine is used as a driver for transformation of the fluid-pressure energy into the mechanical energy.			
	Steam-powered driver-compressor	A fluid-pressure-energy powered driver-compressor in which pressurized steam is used as a primary energy source.		
		Steam-turbine compressor	A mechanical compressor with a steam turbine as a driver	
		Separable steam-turbine compressor	A mechanical compressor and a steam turbine as a driver connected by a coupling.	 <p>Compressor</p> <p>Steam turbine</p>
Integral steam-turbine compressor	A mechanical compressor and steam turbine as a driver having the common torque-transmitting one-piece or composed shaft.	 <p>Compressor section</p> <p>Steam-turbine section</p>		

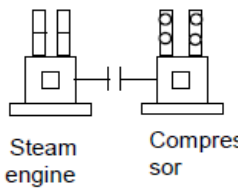
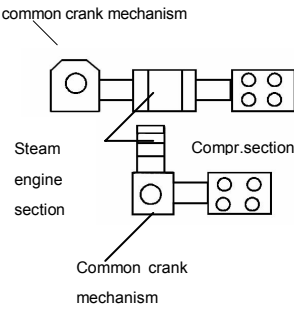
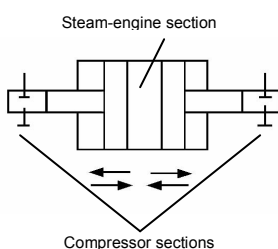
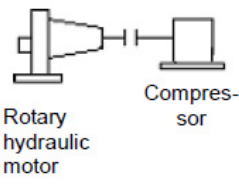
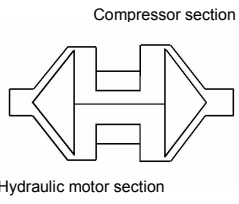
Class, term	Subclass and definition		Illustration (example only)		
Fluid-pressure-energy powered driver-compressor (generic term) (continued)	Steam-powered driver-compressor	Steam-engine compressor	A mechanical compressor with a reciprocating steam engine as a driver	 <p>Steam engine Compressor</p>	
			Separable steam-engine compressor	A mechanical compressor and a reciprocating steam-engine as a driver having separate power-output shaft and connected by a coupling	 <p>common crank mechanism</p> <p>Steam engine section Compr. section</p> <p>Common crank mechanism</p>
			Integral steam-engine compressor (compound steam-engine compressor)	A mechanical reciprocating compressor and integrated steam engine as a driver having the common crankshaft and crankcase for both crank mechanisms.	 <p>Steam-engine section</p> <p>Compressor sections</p>
	Hydraulic-motor compressor (pressurized-oil- powered compressor)	A fluid-pressure-energy powered driver-compressor in which a pressurized oil or other liquid is used as a primary energy source.			
		Rotary-hydraulic-motor-compressor	A hydraulic-motor compressor in which a rotary hydraulic motor is used as a driver	 <p>Rotary hydraulic motor Compressor</p>	
			Integral rotary-hydraulic-motor-compressor	A rotary-hydraulic-motor-compressor in which the hydraulic motor and compressor have a common torque-transmitting one-piece or composed shaft.	 <p>Compressor section</p> <p>Hydraulic motor section</p>

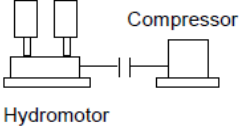
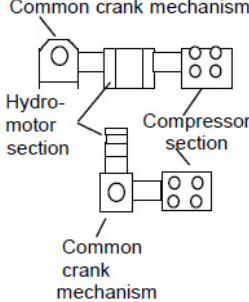
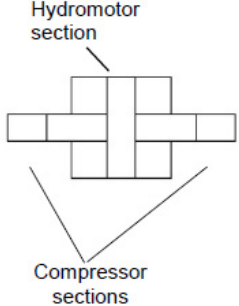
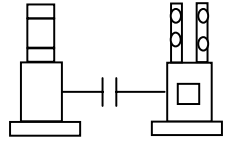
Class, term	Subclass and definition		Illustration (example only)	
Fluid-pressure-energy powered driver-compressor (generic term) (continued)	Hydraulic-motor compressor (pressurized-oil-powered compressor) (continued)	Reciprocating-hydraulic-motor-compressor	A hydraulic-motor compressor in which a reciprocating-hydraulic motor is used as a driver	
		Separable reciprocating-hydraulic-motor-compressor	A reciprocating-hydraulic-motor-compressor in which the hydraulic motor has a separate power-output shaft connected with the compressor shaft by a coupling.	
		Integral reciprocating-hydraulic-motor-compressor (compound reciprocating-hydraulic-motor-compressor)	A reciprocating-hydraulic-motor-compressor in which the hydraulic motor and compressor have the common crankshaft and crankcase for both crank mechanisms.	
		Free-piston hydraulic-motor-compressor	A shaftless reciprocating-hydraulic-motor-compressor in which driving forces of the built-in hydraulic motor act directly on the reverse side of the compressor piston. NOTE 3 As a rule these compressors are combined with electrically driven liquid pumps introduced in the liquid-circulation loop (see combined-energy powered driver-compressors below).	
Expander-compressor (componder; pressurized-gas-powered compressor)	A fluid-pressure-energy powered driver-compressor in which a pressurized gas or air is used as a primary energy source			
	Reciprocating-expander-compressor (Reciprocating componder)	An expander-compressor in which a reciprocating expander is used as a driver		
	Separable reciprocating-expander-compressor (Separable reciprocating componder)	Reciprocating-expander-compressor in which the expander has a separate power-output shaft connected with the compressor shaft by a coupling		

Class, term	Subclass and definition			Illustration (example only)	
Fluid-pressure-energy powered driver-compressor (generic term) (continued)	Expander-compressor (compander; pressurized-gas-powered compressor) (continued)	Reciprocating-expander-compressor (Reciprocating compander) (continued)	Integral reciprocating-expander-compressor (Integral reciprocating compander)	A reciprocating-expander-compressor in which the expander and compressor have the common crankshaft and crankcase for both crank mechanisms.	
			Free-piston expander-compressor (Free-piston compander)	A shaftless reciprocating-expander-compressor in which driving forces of the built-in expander act directly on the reverse side of the compressor piston	
		Rotary-expander-compressor (Rotary compander)	An expander-compressor in which a rotary expander is used as a driver. NOTE 4 The rotary expander most used for driving compressors is the screw expander.		
		Separable rotary expander-compressor (Separable rotary compander)	A rotary expander - compressor in which the expander has a separate power-output shaft connected with the compressor shaft by a coupling.		
		Integral rotary expander-compressor	A rotary expander-compressor in which the expander and compressor have a common torque-transmitting one-piece or composed shaft.		
		Turbo-expander-compressor	An expander-compressor in which a turbo expander is used as a driver		
		Separable turbo expander-compressor (Separable turbo compander)	A turbo expander-compressor in which the expander has a separate power-output shaft connected with the compressor shaft by a coupling.		

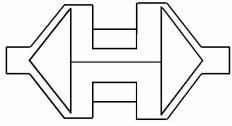
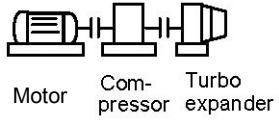
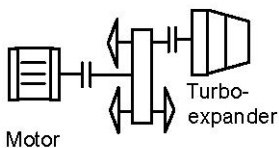
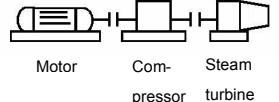
Class, term	Subclass and definition				Illustration (example only)
Fluid-pressure-energy powered driver-compressor (generic term) (continued)	Expander-compressor (compander; pressurized-gas-powered compressor) (continued)	Turbo-expander-compressor (continued)	Integral turbo-expander-compressor (Integral turbo-compander)	A turbo-expander-compressor in which the expander and compressor have a common torque-transmitting one-piece or composed shaft.	 <p>Turbo-expander section Compressor section</p>
<p>NOTE 5 For simplification of matching working-member speeds as well as generated and consumed energy values, the fluid-pressure-energy powered compressors (particularly, hydraulic-motor compressors and expander-compressors) are completed with drivers and compressors of the same motion type (e.g. reciprocating piston expander plus reciprocating shaft-driven piston compressors).</p> <p>NOTE 6 In modern practice, the crank mechanism is used mostly in integral reciprocating driver-compressors (integral ICE-compressor, integral steam-engine compressors, integral reciprocating hydraulic-motor compressors and integral reciprocating expander-compressors) as a common motion-converting mechanism.</p>					
Combined-energy-powered driver-compressor	A mechanical compressor with two or more drivers using different forms of available external primary energy				
	Simultaneously powered (parallel-powered) driver-compressor (Simultaneously combined-energy-powered driver-compressor)	<p>A combined-energy-powered driver-compressor in which drivers of different type share the total load in part-load (load-sharing) or part-time (time-sharing) modes.</p> <p>NOTE 7 Simultaneously powered driver-compressors are mostly used in oil/gas processing, chemical and petrochemical plants with a purpose to utilize secondary energy resources, e.g. gas or steam-pressure energy generated by recovery of waste heat of chemical reactions and flue-or off-gases.</p>			
		Motor-expander compressor (Motor-compander)	A simultaneously powered driver-compressor in which motor and expander are used as different driver types.		 <p>Motor Com-pressor Turbo expander</p>  <p>Motor Turbo-expander</p> <p>Integrally geared compressor</p>
		Motor-steam-turbine compressor	A simultaneously powered driver-compressor in which motor and steam turbine are used as different driver types.		 <p>Motor Com-pressor Steam turbine</p>
	Successively powered driver-compressor (Successively combined-energy-powered driver-compressor)	<p>A combined-energy-powered driver-compressor in which one of the drivers converts first the total necessary amount of external energy into the other form and the second driver actuates directly the compressor working members using the second form of energy.</p> <p>NOTE 8 An electric motor is used in common practice as the primary driver and a hydromotor serving as the secondary one.</p>			

© ISO 2012. All rights reserved.

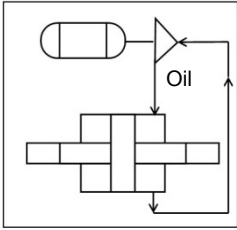
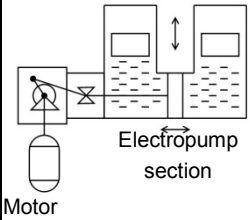
Class, term	Subclass and definition		Illustration (example only)
Combined-energy-powered driver-compressor (continued)	Successively powered driver-compressor (Successively combined-energy-powered driver-compressor (continued))	Electropump-hydromotor compressor	A successively powered driver-compressor in which the primary electric motor converts the electric energy by means of a liquid pump into the potential energy of the oil pressure, which in turn actuates further the free-piston hydraulic-motor compressor.
		Separable electro- pump-hydromotor compressor	An electropump-hydromotor compressor in which the electropump is performed as a separate machine from which the pressurized oil is supplied to the hydromotor by a separate oil pipeline.
		Integral electro-pump-hydromotor compressor	An electropump-hydromotor compressor in which electropump and compressor have a common working member with a floating compressor piston(s).
Electropump  Free-piston hydraulic-motor compressor	Hydromotor-compressor section 		

4.4 Design classes of geared driver-compressors

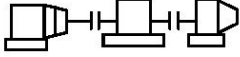
Class, term	Subclass and definition		Illustration (example only)
Geared driver-compressor (generic term)	Separable-geared driver-compressor	A geared driver-compressor in which every component: mechanical compressor, gear and driver have their separable shafts connected with each other by couplings.	 <p>driver gear compressor</p> <div style="border: 1px solid black; padding: 5px; width: fit-content; margin: 10px auto;"> Formula: $D + G + C$ </div> <p>Where are:</p> <ul style="list-style-type: none"> D – driver G – gear C – compressor

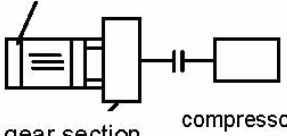
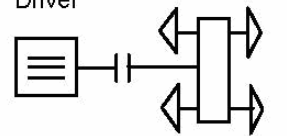
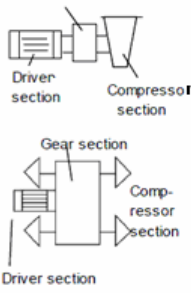
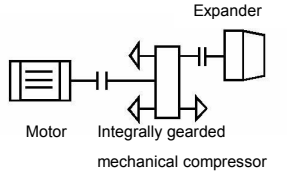
Class, term	Subclass and definition		Illustration (example only)
Geared driver-compressor (generic term) (continued)	Separable compressor with internally geared driver (separable gearmotor-compressor)	<p>A geared driver-compressor in which driver and drive wheel of the gear have a common shaft and the mechanical compressor has a separable shaft connected with the power-output shaft of the gear by a coupling.</p> <p>NOTE 1 In this and other illustrations, integral non-separable and built-in components are shown in parentheses.</p>	<p>driver section</p>  <p>gear section compressor</p> <div style="border: 1px solid black; padding: 5px; width: fit-content; margin: 10px auto;"> <p>Formula: $(D + G) + C$</p> </div>
	Integrally geared compressor with separable driver (separable-driven integrally geared compressor)	<p>A geared driver-compressor in which the driver has a separate power output shaft connected with the input gear shaft of the integrally geared mechanical compressor by a coupling.</p>	<p>Driver</p>  <p>integrally geared compressor</p> <div style="border: 1px solid black; padding: 5px; width: fit-content; margin: 10px auto;"> <p>Formula $D + (G + C)$</p> </div>
	Integrally geared driver-compressor	<p>A geared driver-compressor in which the driver and the drive wheel of the gear on one hand, and the gear-power-output wheel(s) and compressor working member(s) on the other hand, have common torque-transmitting shafts.</p> <p>NOTE 2 In an integrally geared driver compressor, no coupling is used.</p>	 <div style="border: 1px solid black; padding: 5px; width: fit-content; margin: 10px auto;"> <p>Formula: $(D + G + C)$</p> </div>
	Combined-energy-powered geared driver-compressor	<p>A geared driver-compressor with two or more drivers which use different forms of external energy and are connected to different power-input shafts of the gear.</p> <p>NOTE 3 This subclass can have its own subclasses according to different integration grades of driver and gears: $D+G+C$; $(D+G)+C$; $D+(G+C)$; $(D+G)+C$</p>	 <p>Motor Integrally geared mechanical compressor Expander</p>
<p>NOTE 4 All subclasses of geared driver-compressors can have additional subclasses according to the applicable gear and driver design variants presented in Figures 2 and 3, e.g. "separable-geared motor-compressors"; "separable compressor with integrally geared motor-compressor" (or "gearmotor-compressor"); "Integrally geared compressor with separable gas turbine".</p>			

4.5 Design and service-duty classes of compressor plants

4.5.1 Cooling classes

Class term	Subclass and definition					
Compressor plant (generic term)	Non-cooled compressor plant	A compressor plant in which no forced streams of cooling agents are provided for removal of heat from the compressed gas.				
	Air-cooled compressor plant	A compressor plant in which the compression heat is removed from the compressed gas in surface-type heat exchangers by convection and heat conduction through walls transferring it to the forced atmospheric air flow generated by a fan on the reverse side of said walls.				
	Water-cooled compressor plant	<p>A compressor plant in which the compression heat is removed from the compressed gas in surface-type heat exchangers by convection and heat conduction through walls transferring it to the forced water flow generated by a pump on the reverse side of said walls.</p> <p>NOTE 1 The compression heat is finally transferred to the atmospheric air (by use of closed-loop water-circulation systems including cooling towers) or to the natural water resources: rivers, lakes, etc. (by use of open water-circulation systems).</p>				
	Closed-loop water/air-cooled compressor plant	A compressor plant in which the compression heat is removed from the compressed gas in surface-type heat exchangers by convection and heat conduction through walls transferring it to the forced water which circulates in a closed loop including a pump and is cooled in turn in a second surface-type heat exchanger by forced atmospheric air flow generated by a fan.				
	Water-injection cooled compressor plant	A compressor plant in which the compression heat is removed from the compressed gas in a contact type heat exchanger by heat withdrawal thanks to evaporation of water aerosols injected in the compressed gas stream.				
	Closed-loop oil-cooled compressor plant	<p>A compressor plant in which the compression heat is removed simultaneously from the compressed gas during its compression by convection and partly by evaporation of oil aerosols injected directly in the working chambers, the oil being separated and circulated in a closed loop and cooled in turn in a surface-type heat exchanger of the compressor plant by an external cooling agent, the remaining part of the compression heat from the compressed gas being removed in a special section of the said heat exchanger.</p> <p>NOTE 2 Water or other liquids can be used instead of oil.</p> <p>NOTE 3 In some applications, additional external cooling of the compressed gas cannot be provided.</p> <p>NOTE 4 In some cases (e.g. for high-pressure application), the additional cooling can be performed in separate heat exchangers.</p> <p>Subclasses by heat-removal methods from the circulating oil.</p> <table border="1" data-bbox="560 1541 1402 1718"> <tbody> <tr> <td data-bbox="560 1541 786 1630">Closed-loop oil-/air-cooled compressor plant</td> <td data-bbox="791 1541 1402 1630">A closed-loop oil-cooled compressor plant in which the circulating oil is cooled in a air-cooled surface-type heat exchanger.</td> </tr> <tr> <td data-bbox="560 1637 786 1718">Closed-loop oil-/water-cooled compressor plant</td> <td data-bbox="791 1637 1402 1718">A closed-loop oil-cooled compressor plant in which the circulating oil is cooled in a water-cooled surface-type heat exchanger.</td> </tr> </tbody> </table>		Closed-loop oil-/air-cooled compressor plant	A closed-loop oil-cooled compressor plant in which the circulating oil is cooled in a air-cooled surface-type heat exchanger.	Closed-loop oil-/water-cooled compressor plant
Closed-loop oil-/air-cooled compressor plant	A closed-loop oil-cooled compressor plant in which the circulating oil is cooled in a air-cooled surface-type heat exchanger.					
Closed-loop oil-/water-cooled compressor plant	A closed-loop oil-cooled compressor plant in which the circulating oil is cooled in a water-cooled surface-type heat exchanger.					

12

4.5.2 Lubrication classes

Class, term	Subclass and definition	
Compressor plant (generic term)	Oil-free compressor plant	A compressor plant with a displacement compressor operating without injection of lubricating liquid into the working chambers in which the compressed gas does not come into contact with any lubricant thanks to their rubbing parts being made of self-lubricating materials, or working members moving without contact with each other or with working chamber surfaces. NOTE 1 Oil-free compressor plant does not need any oil-separation equipment.
	Lubricated piston compressor plant	A piston compressor plant in which lubricating oil is injected in the gap between the piston and cylinder wall in quantities sufficient to establish continuous stable oil film on the rubbing surfaces for elimination of dry friction on the contacting surfaces, oil-separation equipment being provided after the each compression stage.
	Mini-lubricated piston compressor plant	A crosshead-type piston compressor plant without oil injection into the working chamber(s), piston/cylinder contact surfaces being lubricated by small quantities of oil penetrating into the cylinder along the piston rod from the lubricated piston-rod packing. NOTE 2 Piston and guide rings of mini-lubricated compressor are made as a rule from self-lubricated or low-friction materials. NOTE 3 Depending on air-quality requirements oil-separation equipment can be provided in mini-lubricated piston compressor plants.
	Liquid-flooded rotary compressor plant	A rotary compressor plant in which liquid is injected in the working chamber(s) in quantities sufficient to build gas-liquid mixture and perform simultaneously duties of rubbing-surface lubrication, cooling the gas being compressed and sealing gaps between working member(s) and working chamber surfaces said liquid being extracted from the gas in oil separators, cooled by external cooling agent and circulated in a closed loop. NOTE 4 Liquid-type subclasses are: — oil-flooded rotary compressor plants; — water-flooded rotary compressor plants, etc. NOTE 5 Oil-flooded screw and sliding-vane compressor plants are the most typical representatives of this class.

4.5.3 Service-pressure classes

Class and subclass		Definition
Suction-pressure classes	Atmospheric suction-pressure compressor plant	A compressor plant for operation at suction pressures equal to or around the atmospheric pressure.
	Booster compressor plant	A compressor plant for operation at suction pressures above the atmospheric pressure.
	Vacuum-compressor plant	A compressor plant for operation at suction pressures below the atmospheric pressure.
	Two-suction-pressure compressor plant (Side-stream compressor plant)	A compressor plant with inter-stage gas in-flow under the intermediate gas pressure.
	Exhausting – down compressor plant	A compressor plant operating cyclically with constant discharge and variable (falling) suction pressure. NOTE 1 If the exhausting-down compressors can be used for gas recovery from LPG-transportation tanks.
Discharge-pressure classes	Ultra-low-pressure compressor plants	A compressor plant for absolute discharge pressures up to 2 bar ¹⁾ .

1) 1 bar = 0,1 MPa = 10⁵ Pa; 1 MPa = 1 N/mm².

Class and subclass		Definition
Class and subclass		Definition
Discharge-pressure classes (continued)	Low-pressure compressor plants	A compressor plant for absolute discharge pressures in the range of 2 bar to 15 bar.
	Medium-pressure compressor plants	A compressor plant for absolute discharge pressures in the range of 16 bar to 101 bar.
	High-pressure compressor plant	A compressor plant for absolute discharge pressures in the range of 101 bar to 1 001 bar.
	Ultra-high-pressure compressor plants (Hyper compressor plants)	A compressor plant for absolute discharge pressures exceeding 1 001 bar.
	Two-discharge-pressure compressor plants	A compressor plant with inter-stage gas take-off under the intermediate gas pressure.
	Pumping-up compressor plants	A compressor plant operating cyclically with constant suction and variable, periodically increasing discharge pressure. NOTE 2 The pumping-up compressors can be used for filling high-pressure gas cylinders.
Combined-service and relative-pressure classes	Multi-service compressor plant	A compressor plant with several working chambers for simultaneous compression of different gaseous media in independent suction/discharge-pressure modes. NOTE 3 Where the term "multi-service" is absent, all compressors are considered single-service compressors for compressing single gaseous medium.
	Multi-media compressor plant	A compressor plant for alternative compression of different gaseous media in the same working chambers under the same or different suction-/discharge-pressure modes. NOTE 4 If the term "multi-media" is absent, all compressors are considered single-media compressors.
	Exhausting/pumping-up compressor plant	A compressor plant with simultaneously variable suction and discharge pressures.
	Blower plant	A compressor plant with discharge-/suction-pressure increase ratios not exceeding 2,0 regardless of the absolute pressure level.
	Circulator-compressor plant	A compressor plant for circulation of the process gas in the closed circuit overcoming only its hydraulic resistance regardless of the absolute pressure level.
	Single-stage compressor plant	A compressor plant in which the pressure increase from the given suction pressure to the required discharge pressure is achieved in one compression stage regardless of the absolute pressure level.
	Multi-stage compressor plant	A compressor plant, in which the pressure increase from the given suction pressure to the required discharge pressure is achieved by successive compression of the gaseous medium in two or more stages with intermediate cooling to remove the compression heat.
NOTE 5 Individual definitions of service-media classes (see Figure 4) are not necessary because the wording of the terms characterizes sufficiently the basic service-media properties.		

4.6 Design classes of packaged compressor plants

4.6.1 Mobility classes

Class and subclass		Definition							
Packaged compressor plant (generic term)	Stationary packaged compressor plant	<p>A compressor plant which is not adapted to changes in location in respect of the compressed-gas consuming equipment during the whole service-life period.</p> <p>NOTE 1 Subclasses of the stationary compressor plants are: Receiver-mounted; Cooler-mounted; Skid-mounted; Slide-mounted etc.</p> <p>NOTE 2 Any non-packaged compressor plant is also related to the stationary subclass supplied in separate equipment.</p>							
	Relocatable (redeployable) packaged compressor plant	<p>A packaged self-contained compressor plant adapted for continuous long-period operation at several locations, which can be dragged to new operating places without disassembly by means of temporary towing vehicles or devices.</p> <p>NOTE 3 Subclasses of the relocatable packaged compressor plant are: — slide-mounted; — receiver-mounted, etc.</p>							
	Mobile (portable) compressor plant	<p>A packaged self-contained compressor plant adapted for frequent relocation of its operating place by help of regular component-part or specially attached transport means for servicing different compressed-gas users.</p> <table border="1"> <tr> <td>Wheeled (crawler-mounted) mobile compressor plant</td> <td>A mobile compressor plant mounted on the wheeled (or crawler-mounted) chassis or receiver and transported to different operating places by service personal or by means of towing vehicles</td> </tr> <tr> <td>Trailer-mounted mobile compressor plant</td> <td>A wheeled mobile compressor plant mounted on a trailer</td> </tr> <tr> <td>Trolley-mounted (hand-towed) mobile compressor plant</td> <td>A small wheeled mobile compressor plant mounted on a trolley and towed by the service personal</td> </tr> <tr> <td>Self-propelled compressor plant</td> <td>A wheeled (or crawler-mounted) mobile compressor plant mounted on a appropriate vehicle and adapted for frequent change of its operating place autonomously without use of any external towing vehicles</td> </tr> </table>	Wheeled (crawler-mounted) mobile compressor plant	A mobile compressor plant mounted on the wheeled (or crawler-mounted) chassis or receiver and transported to different operating places by service personal or by means of towing vehicles	Trailer-mounted mobile compressor plant	A wheeled mobile compressor plant mounted on a trailer	Trolley-mounted (hand-towed) mobile compressor plant	A small wheeled mobile compressor plant mounted on a trolley and towed by the service personal	Self-propelled compressor plant
Wheeled (crawler-mounted) mobile compressor plant	A mobile compressor plant mounted on the wheeled (or crawler-mounted) chassis or receiver and transported to different operating places by service personal or by means of towing vehicles								
Trailer-mounted mobile compressor plant	A wheeled mobile compressor plant mounted on a trailer								
Trolley-mounted (hand-towed) mobile compressor plant	A small wheeled mobile compressor plant mounted on a trolley and towed by the service personal								
Self-propelled compressor plant	A wheeled (or crawler-mounted) mobile compressor plant mounted on a appropriate vehicle and adapted for frequent change of its operating place autonomously without use of any external towing vehicles								

Class and subclass		Definition	
Packaged compressor plant (generic term) (continued)	Mobile (portable) compressor plant (continued)	Hand-portable compressor plant	A small mobile lightweight trunk-mounted compressor plant which can be carried to any operating place by the service personal
	Transport- mounted packaged compressor plant	<p>A packaged compressor plant adapted for mounting and operation on board a mobile compressed-gas user such as transport means, construction equipment etc.</p> <p>NOTE 4 Subclasses of transport mounted compressor plants are:</p> <ul style="list-style-type: none"> — ship-board compressor plant; — tram-board compressor plant; — train-board compressor plant; — truck-board compressor plant; — crane-board compressor plant, etc. <p>NOTE 5 On board a large mobile compressed-gas user the previously shown packaged compressor plants of all mobility classes can be operated, e.g.:</p> <ul style="list-style-type: none"> — ship-board stationary compressor plant; — ship-board relocatable compressor plant; — ship-board mobile trolley-mounted (hand-towed) compressor plant; — ship-board hand-portable compressor plant. <p>NOTE 6 Some transport-mounted packaged compressor plants can be supplied without their own drivers as mechanical (or geared mechanical) compressor plants driven by a power-take-off shaft of the transport means.</p>	

4.6.2 Compressor-number classes

Class and subclass		Definition
Packaged compressor plant (generic term)	Packaged single-compressor plant	A packaged compressor plant containing one mechanical compressor.
	Packaged twin-compressor plant	A packaged compressor plant containing two mechanical compressors mounted on a common supporting base (skid, receiver, slide, etc.).
	Packaged triple-compressor (or multi- compressor) plant	A packaged compressor plant containing three (or more) mechanical compressors mounted on a common supporting base (skid, receiver, slide, etc.).
	<p>NOTE 1 Twin, triple or other packaged multi-compressor plants can have further subclasses depending on:</p> <ul style="list-style-type: none"> — connecting schemes of incorporated compressors: parallel or tandem (successively on cascades); — auxiliary-apparatus integration degrees (individual coolers, separators etc. or combined ones for two or several compressors); — design classes of compressors (compressors of similar or different design); — differences in capacities of incorporated compressors (single-size or different-size), etc. 	

4.6.3 Enclosure-type classes

Class and subclass		Definition
Enclosed packaged compressor plant	Silenced packaged compressor plant	A packaged compressor plant with a noise-suppressing enclosure. NOTE 2 This type of compressor plants can have in turn a further subclass of partly enclosed compressor plant in which only the most intensive noise emitters: driver, gear, mechanical compressor are placed under the enclosure.
	Weather-protected compressor plant	A packaged compressor plant placed in an enclosure protecting the compressor equipment from atmospheric effects and adapted to operation outdoors in the open air.
	Container-type packaged compressor plant	A packaged compressor plant placed in a container adapted for operation outdoors in the open air and equipped with inside ambient-air monitoring system enabling maintenance and repair operations at any weather or seasonal conditions.
	Encapsulated compressor plant	A packaged compressor plant placed in a hermetic enclosure (capsule) which eliminates leakages of gas into the ambient atmosphere as well as penetration of the ambient air into the compressor equipment.

Annex A (informative)

Design, functional and service-duty classification

A.1 Design classification of compressors

The terms “design classes” or “design classification” are accepted as a short designation for the complex classification of compressors by design features, equipment types and operation principles.

A hierarchical classification tree is adopted as a base for the design classification. The hierarchical concept gives a complete and integral perception of the whole classification system with clear visual review of all design subclasses with their links, subordination relationships and realization variants.

Classification by equipment type is admitted as the first top level of the classification tree with the classes “compressor apparatuses” and “compressor machines” because these classes are already on the market.

Ejectors, well-known dynamic-type compressors, are referred to as the megaclass “compressor apparatuses” (dynamic subclass) because they have no moving, solid working members or machine parts. Within the megaclass “compressor machines”, only “turbocompressors” remain as dynamic-type compressor machines because no other type of movement is known in high-speed dynamic-type machines, except rotation. That is why the terms “dynamic compressor machines” and “turbocompressors” can be considered synonymous.

The next level of classification is by operation principles inside the equipment type.

Several new compressor machine types are presented on the level of design subclasses of the classification tree: scroll, single screw, cross-flow, peripheral-flow, trochoidal, etc.

In some cases, several subclasses, formerly considered separate, are grouped into the more general subclasses of the higher level if they have common design principles. For example, liquid-ring, sliding vane and swing-vane single-rotor compressors are united under the generic subclass of multi-segment compressors. The increase and decrease of working chamber volumes in all these design types are performed by passing them through the crescent-shaped space of variable height between the cylindrical housing and eccentrically positioned rotor. The introduction of this generic term allows the formulation of more accurate and simplified definitions of the subclasses emphasizing at the same time more precisely their essential differences in design features.

The scroll compressor usually related to rotary compressors is presented as a separate subclass of positive-displacement compressors because the classical scroll rotor does not rotate around its axis, but performs the plane-parallel (orbital) movement.

Open classes are provided for future design types, which can be included in the general classification tree without its rearrangement by their implementation into industrial practice.

The formulation of lower level subclass definitions of the classification tree is based on the principle of non-repetition of the common features of higher level more general terms, but adding only specific features and attributes of particular design subclasses.

Piston compressors are presented in the classification tree with the largest number of subclasses. This fact can be explained by the longest period of development and by a complicated design with a number of components for transmission and conversion of the mechanical energy.

The design terms and their definitions are shown in this Technical Report with their appropriate graphical illustrations in the same horizontal cell.

The term “design class” is used in this Technical Report at all levels of the classification system where there is no need to stress the subordination of design variants. The term “design subclass” is used to express the position of lower level classes relative to higher level equipment types.

Design classes of compressors considered in the part 2 of this Technical Report do not relate to the aggregated compressor equipment, including auxiliaries with their own functions: gears, motors, apparatuses, etc. (except free-piston compressors and integral engine-compressors, in which some compressor parts are coincident with engine parts). Auxiliary equipment with its multiple versions and configurations brings the additional design variety into the complete design of the aggregated equipment and results in further extension and complication of the design classification.

For the elaboration of design classification of the aggregated compressor equipment, it was necessary to investigate and systematize basic completion variants of the aggregated equipment with different structural and functional components and formulate corresponding functional classes.

A.2 Functional classification of the aggregated compressor equipment

The functional classes are not dependent on design features. The basic principle of their formation is the presence or absence of different functional elements.

Functional classes are new for ISO 5390 and define the extent of basic structural and functional component parts of compressor equipment common to all design types from so-called “air ends” to complete packaged compressor plants.

Functional classes are important for technical and economical comparison and evaluation of different compressor alternatives in correct conditions. Absence of this classification, appropriate terminology and their standard definitions brings into practice too much confusion because many technical and economical parameters (power consumption, availability and dependability factors, dimensions, mass, prices, etc.) are dependent on the extension of structural and functional composition of the compressor equipment. There are many publications on technical and economical efficiency of compressors without specification of what is implied by the terms “compressor” or “compressor equipment”. Even the phrase “motor-driven compressor with mass of 3 200 kg” does not make it clear whether or not the mass of the motor is included in the 3 200 kg. This is because, in many cases, the word “motor” is considered only an attribute to the compressor, but not a part of the equipment.

The analysis of aggregated compressor-equipment supply variants realized by manufacturers has shown that the following most typical processes or operations can be included in the extent of functions of the compressor equipment:

- displacement or compression of the gas in the compression mechanism (or device) of certain design type by supply of mechanical energy to the working members in the form acceptable for this mechanism;
- conversion of the initial external energy (electricity, fuel heat, fluid pressure, etc.) into mechanical energy in the driver;
- conversion of the mechanical energy of the driver in initial form (e.g. the rotating movement of the driver-output shaft) into the mechanical energy of the other form acceptable for the working member of the specific compressor mechanism (reciprocating, swinging, orbital, etc.);
- conversion of the initial speed of driving members (rotation or stroke frequencies of driving shafts, pistons, rods, etc.) into the necessary speed of compressor working members;
- cooling the gas compressed or being compressed;
- separation of the gas from the liquid phase, abrasion products of mechanical parts and other mechanical contaminants;
- drying of the gas;

- suppression of pressure pulsations in piping, apparatuses and flow passages of the compressor;
- attenuation of the noise emitted by compressor and auxiliary equipment;
- provision of certain storage volume of the compressed gas to assure necessary stability of the gas pressure at the end users by different rate of compressed gas consumption;
- facilitation of assembly, mounting and start-up operations of the compressor equipment on site by packaging and carrying out these operations in industrial/factory conditions and increasing therewith quality, reliability and efficiency of the equipment.

On the basis of these functions, the structural chain of compressor-equipment functional components can be presented for the typical case as the following: compression mechanism (or device) – mechanism for conversion of motion character (rotating/reciprocating, etc.) – speed-adjusting gear – driver – auxiliary gas processing equipment (for admission, cooling, filtering, separating, piping, pulsation dampening, control, instrumentation, etc.) – aftercooler – base for packaging, assembly, mounting – dryer – receiver – enclosure.

The listed sequence of components is the most typical variant of the gradually increasing pattern of equipment functions from the minimum to the maximum extent at the modern stage of the compressor industry. Functional classes corresponding to these grades are admitted in this Technical Report as basic ones.

The problem with functional classification is further complicated where one or several functional components is/are missing from the components chain. Very often, the compressor equipment is supplied without a driver, which is instead delivered directly from the specialized manufacturer to the place of operation. This variant is common where compressor plants are exported to various countries and completed with electric motors from the local producers.

All possible random combinations of functional components of the compressor equipment are admitted in this Technical Report as derivative functional classes.

For elaboration of basic functional classes, the following methodical principles are used:

One of the basic principles proposed for compressor machines is to introduce the term “mechanical compressor” for all kinds of devices compressing or displacing gases by supply of external mechanical energy to their shaft, piston-rod or other energy-taking part. Other basic classification terms are also related to primary energy sources and their conversion schemes, e.g. motor-compressors require electrical energy for their operation, steam-turbine compressors need the potential energy of steam pressure, gas-turbine compressors require the chemical energy of natural gas, etc. Besides, it is important that the term “mechanical compressor” can be translated into all languages using exact parallel terms. It is just the contrary with “air ends”, “bare compressors” and other elemental arbitrary “terms”.

The second proposal is to admit the term “plant” where all interstage apparatuses, instrumentation, control and piping necessary for safe operation using application of outside energy are included in the extent of the compressor equipment regardless of the presence or lack of specific driving systems, e.g. there can be “mechanical compressor plant”, i.e. without motor or “motor-compressor plant”).

The third proposal is to expand the term “integral”, formerly used only for specific design types to all design types of component combinations such as “driver-compressor”, “driver-gear”, “gear-compressor” or “driver-gear-compressor”, where the mechanical energy from one component to the other is transmitted by common shaft, rod or piston without the use of couplings and these components are designed as a single non-separable unit. The terms without attribute “integral” designate a plurality of separate equipment components assembled in a energy-transmitting chain by a coupling or couplings. In these cases intersection of design and functional classes takes place with coincidence of some terms.

The fourth proposal is to avoid terms, such as “unit”, “block”, “assembly”, “set”, “aggregate”, “complex”, “system”, “assemblage”, “grouping”, “series”, etc. because of their multivalence, polysemy, difficulties in adequate and relevant translation into the different languages by keeping admitted specific meanings as well as synonymy in the most applications.

The functional classification of compressor apparatuses is simpler because their energy-transmitting chain does not contain components relating to mechanical motion:

- a) motors, engines, etc. for generating mechanical energy;
- b) auxiliary motion-conversion mechanisms (rotating/reciprocating, rotating/orbital, etc.);
- c) speed-adjusting gears.

A.3 Design and service-duty classification of the aggregated compressor equipment

A.3.1 The design classification of the aggregated compressor equipment is more complicated, not only because of the addition of a broader variety of design features of new structural components, but also because of diversity in their combination variants with other equipment components (separable, integral, built-in, etc.).

The general structure of the aggregated-compressor classification system is founded on the basic functional classification.

Table A.1 shows the classification criteria used for different levels of functional classes.

Table A.1 — Functional classes and classification criteria

Functional class	Classification criterion
Mechanical compressor	Operation principles; design types
Geared mechanical compressor	Gear-design types; integration grades
Driver-compressor	Initial external energy forms used; driver-design types; integration grades
Geared driver-compressor	Integration grades
Compressor plant; aftercooled compressor plant	Compressed-gas cooling method; lubrication modes; service-pressure variants; gas-property groups
Packaged compressor plant; packaged compressor plant/dryer; packaged compressor plant/dryer/receiver	Mounting-base design types; mobility grades; number of compressors in the package
Enclosed packaged compressor plant/dryer/receiver	Enclosure types

A.3.2 The classification of aggregated compressor equipment by basic service-duty criteria is related to the “compressor plant/aftercooled compressor plant” functional class levels because for safe and effective operation under appropriate service-duty conditions (pressures, specific gas properties, available cooling agents, oil-free or lubricated modes), the interrelated and coordinated selection, functioning and interaction of all structural components up to the level of the compressor plant (mechanical compressor, driver, coolers, oil separators, etc.) are necessary. On the other hand, additional component parts beyond the “compressor plant/aftercooled compressor plant” level (packaging baseplate, noise-attenuating enclosure, etc.) do not have direct influence on the compressed-gas production process or on the compressor operation conditions and parameters.

A.3.3 Compressor plant cooling classes define directly or indirectly the form of cooling agents (water, air, oil, etc.), basic heat removal processes used (thermal conductivity, convection, evaporation, etc.) and schemes of final heat transfer from the compressed gas to the ambient environment (open loop, closed loop with intermediate cooling agent etc.).

In general, a compressor plant has the following two cooling systems:

- a) for cooling compression chambers in the mechanical compressor (or compressor apparatuses);
- b) for cooling the compressed gas in the complete compressor plant.

These two systems can use similar as well as different cooling agents and methods.

A.3.4 Lubrication classes essentially determine the quality of compressed gases produced by positive-displacement compressors due to the presence or lack of oil or other liquid vapours and aerosols as a consequence of their injection in working chambers to lubricate contacting surfaces, as well as the necessity of using different types of oil-separating equipment within the compressor plants.

The classification of compressor plants by service-pressure classes is according to the following three criteria:

- a) suction-pressure ranges;
- b) discharge-pressure ranges;
- c) combined suction-/discharge-pressure variants.

A.3.5 Analysis of the international market shows that all proposed service-pressure subclasses of compressor plants are used in practice, e.g. the most sophisticated subclass (exhausting/pumping compressor plant with falling suction and rising discharge pressures) is used in LPG (liquid petroleum gas) recovery operations from transportation vessels by exhausting the remaining LPG in gaseous form and filling with it pressure bottles, etc.

A.3.6 Service-media classes define the most important predominant gaseous-media properties and determine basic design materials and specific requirements to allowable leakage rates, compressed-gas treatment processes (dust filtration, condensate separation, cooling, etc.), fire protection, occupational health, control and automation, environmental protection, emission and hazards monitoring, etc., for ensuring the safe operation of compressor equipment.

A.3.7 Problems in mobility classification of the aggregated compressor equipment are connected mainly with portable and board-operated compressor plants.

To avoid confusion, four mobility subclasses are proposed:

- stationary,
- mobile,
- transport-mounted (or board-mounted), and
- relocatable.

For ship-board compressor plants, different subclasses with their own mobility features are introduced, e.g. “ship-board stationary compressor plant” or “ship-board hand-towed mobile compressor plant”. The latter is in fact a “twice mobile” plant.

Bibliography

- [1] ISO 5390, *Compressors — Classification*
- [2] SAFIN, A.H., Fundamentals of modern classification and terminology of the compressor equipment, *Compressors and Pneumatics*. 2008, No. 3 (Part 1, pp. 33–41); No 4 (Part 2, pp. 30–40); No 6 (Part 3, pp. 32–42); No 7 (Part 4, pp.29–38); No 8 (Part 5, pp.31–37)

© ISO 2012. All rights reserved.

ICS 23.140

Price based on 59 pages