



Published 1998-11-01

INTERNATIONAL ORGANIZATION FOR STANDARDIZATION • МЕЖДУНАРОДНАЯ ОРГАНИЗАЦИЯ ПО СТАНДАРТИЗАЦИИ • ORGANISATION INTERNATIONALE DE NORMALISATION

Worms gears — Geometry of worm profiles

TECHNICAL CORRIGENDUM 1

Engrenages à vis cylindriques — Géométrie des profils de vis

RECTIFICATIF TECHNIQUE 1

Technical corrigendum 1 to Technical Report ISO/TR 10828:1997 was prepared by Technical Committee ISO/TC 60, Gears, Subcommittee SC 1, *Nomenclature and wormgearing*.

This material is reproduced from ISO documents under International Organization for Standardization (ISO) Copyright License Number IHS/ICC/1996. Not for resale. No part of these ISO documents may be reproduced in any form, electronic retrieval system or otherwise, except as allowed in the copyright law of the country of use, or with the prior written consent of ISO (Case postale 56, 1211 Geneva 20, Switzerland, Fax +41 22 734 10 79), IHS or the ISO Licensor's members.

Page i

Replace the first element of the English title with the following:

“worm gears”

Page 3

Replace Figure 1 by the new figure on the following page.

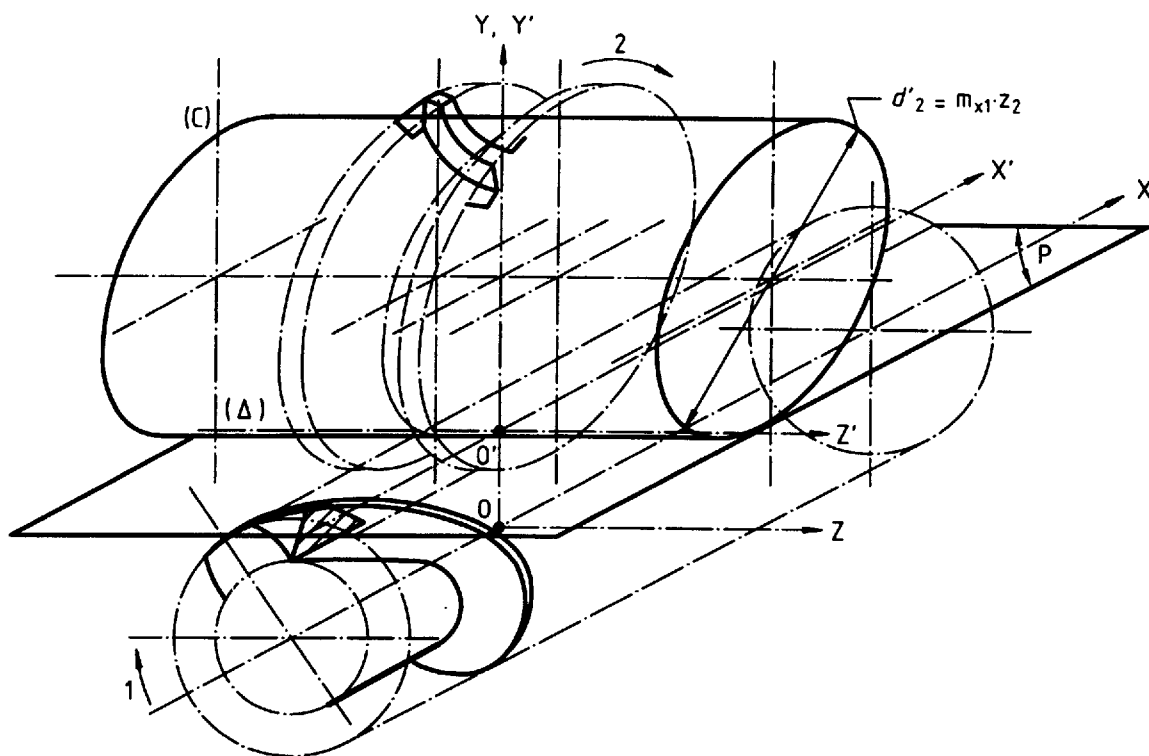

Key

- 1 Direction of rotation of the worm
- 2 Direction of rotation of the wormwheel
- (C) Pitch cylinder of the shaper
- P Pitch plane of the worm
- (Δ) Pitch line

Figure 1 : Conventions used in equations

TECHNICAL REPORT

ISO/TR 10828

First edition
1997-11-15

Worms gears — Geometry of worm profiles

Engrenages à vis cylindriques — Géométrie des profils de vis

This material is reproduced from ISO documents under International Organization for Standardization (ISO) Copyright License number IHS/ICC/1996. Not for resale. No part of these ISO documents may be reproduced in any form, electronic retrieval system or otherwise, except as allowed in the copyright law of the country of use, or with the prior written consent of ISO (Case postale 56, 1211 Geneva 20, Switzerland, Fax +41 22 734 10 79), IHS or the ISO Licensor's members.



Reference number
ISO/TR 10828:1997(E)

ISO/TR 10828:1997(E)

| Contents | Page |
|---|-------------|
| 1 Scope | 1 |
| 2 References | 1 |
| 3 General | 1 |
| 3.1 Definitions | 1 |
| 3.2 Conventions relative to the equations | 1 |
| 4 Profiles | 4 |
| 4.1 Type A | 4 |
| 4.2 Type I | 7 |
| 4.3 Type N | 11 |
| 4.4 Type K | 15 |
| 4.5 Type C | 21 |
| 5 Projection planes | 27 |
| 5.1 Axial plane | 27 |
| 5.2 Offset plane | 27 |
| 5.3 Transverse plane | 27 |
| 5.4 Normal plane | 27 |
| Annex A Bibliography | 29 |

© ISO 1997

All rights reserved. Unless otherwise specified, no part of this publication may be reproduced or utilized in any form or by any means, electronic or mechanical, including photocopying and microfilm, without permission in writing from the publisher.

International Organization for Standardization
 Case postale 56 • CH-1211 Genève 20 • Switzerland
 Internet central@iso.ch
 X.400 c=ch; a=400net; p=iso; o=isocs; s=central

Printed in Switzerland

Foreword

ISO (the International Organization for Standardization) is a worldwide federation of national standards bodies (ISO member bodies). The work of preparing International Standards is normally carried out through ISO technical committees. Each member body interested in a subject for which a technical committee has been established has the right to be represented on that committee. International organizations, governmental and non-governmental, in liaison with ISO, also take part in the work. ISO collaborates closely with the International Electrotechnical Commission (IEC) on all matters of electrotechnical standardization.

The main task of technical committees is to prepare International Standards, but in exceptional circumstances a technical committee may propose the publication of a Technical Report of one of the following types :

- type 1, when the required support cannot be obtained for the publication of an International Standard, despite repeated efforts ;
- type 2, when the subject is still under technical development or where for any other reason there is the future but not immediate possibility of an agreement on an International Standard ;
- type 3, when a technical committee has collected data of a different kind from that which is normally published as an International Standard ("state of the art", for example).

Technical Reports of types 1 and 2 are subject to review within three years of publication, to decide whether they can be transformed into International Standards. Technical Reports of type 3 do not necessarily have to be reviewed until the data they provide are considered to be no longer valid or useful.

ISO/TR 10828, which is a Technical Report of type 3, was prepared by Technical Committee ISO/TC 60, *Gears*, Subcommittee SC1, *Nomenclature and wormgearing*.

Introduction

Thread forms of the worms of worm gear pairs are commonly related to the following machining processes:

- the type of machining process (turning, milling, grinding);
- the shapes of edges or surfaces of the cutting tools used;
- the tool position relative to an axial plane of the worm;
- where relevant, the diameters of disc type tools (grinding wheel diameter).

Worm gears — Geometry of worm profiles

1 Scope

In this Technical Report, thread profiles of the five most common types of worms at the date of publication are described and equations of their axial profiles are given.

The five worm types covered in this technical report are designated by the letters A, C, I, K and N.

2 References

ISO 701-1:—¹⁾, *International gear notation — Part 1: Symbols for geometrical data*.

ISO 1122-2:—²⁾, *Vocabulary of gear terms — Part 2: Geometrical definitions of worm gears*.

3 General

3.1 Definitions

| | |
|--------|---|
| Type A | straight sided axial profile ; |
| Type C | concave axial profile formed by machining with a convex circular profile disc type cutter or grinding wheel ; |
| Type I | involute helicoid, straight generatrix in base tangent planes ; |
| Type N | straight profiles in normal plane of thread space helix ; |
| Type K | milled helicoid generated by biconical grinding wheel or milling cutter, convex profiles in axial planes. |

3.2 Conventions relative to the equations

3.2.1 The worm threads are right-handed.

The equations in this Technical Report define the coordinates of the left flank of the axial profile of worm, i.e. in the plane XOY of figure 1.

To obtain the right flanks, it is necessary to draw a symmetric profile to the left flank relative to a perpendicular axis to the worm axis.

1) To be published. (Revision of ISO 701:1976)

2) To be published.

3.2.2 The worm and wheel pairs operate as speed reducing gears with directions of rotation as shown in figure 1, thus the worm- thread left flanks contact the wheel teeth. These are the flanks studied in this report.

3.2.3 The wormwheel is above the worm.

3.2.4 With the origin O, the reference axes X Y Z, are mutually perpendicular (see figure 1):

- OX the worm axis coincides with the X axis;
- OY the common perpendicular to the worm and wheel axes coincides with the Y axis;
- OZ to complete the direct coordinate system.

A point is defined by its x, y, z coordinates. The following subscripts are used:

- x refers to the X-Y axial plane;
- D refers to an offset plane;
- n refers to the normal plane;
- t for any point refers to a transverse plane.

3.2.5 If the worm is driving, the worm gear is a reducer. If the worm wheel is driving the worm gear is an increaser.

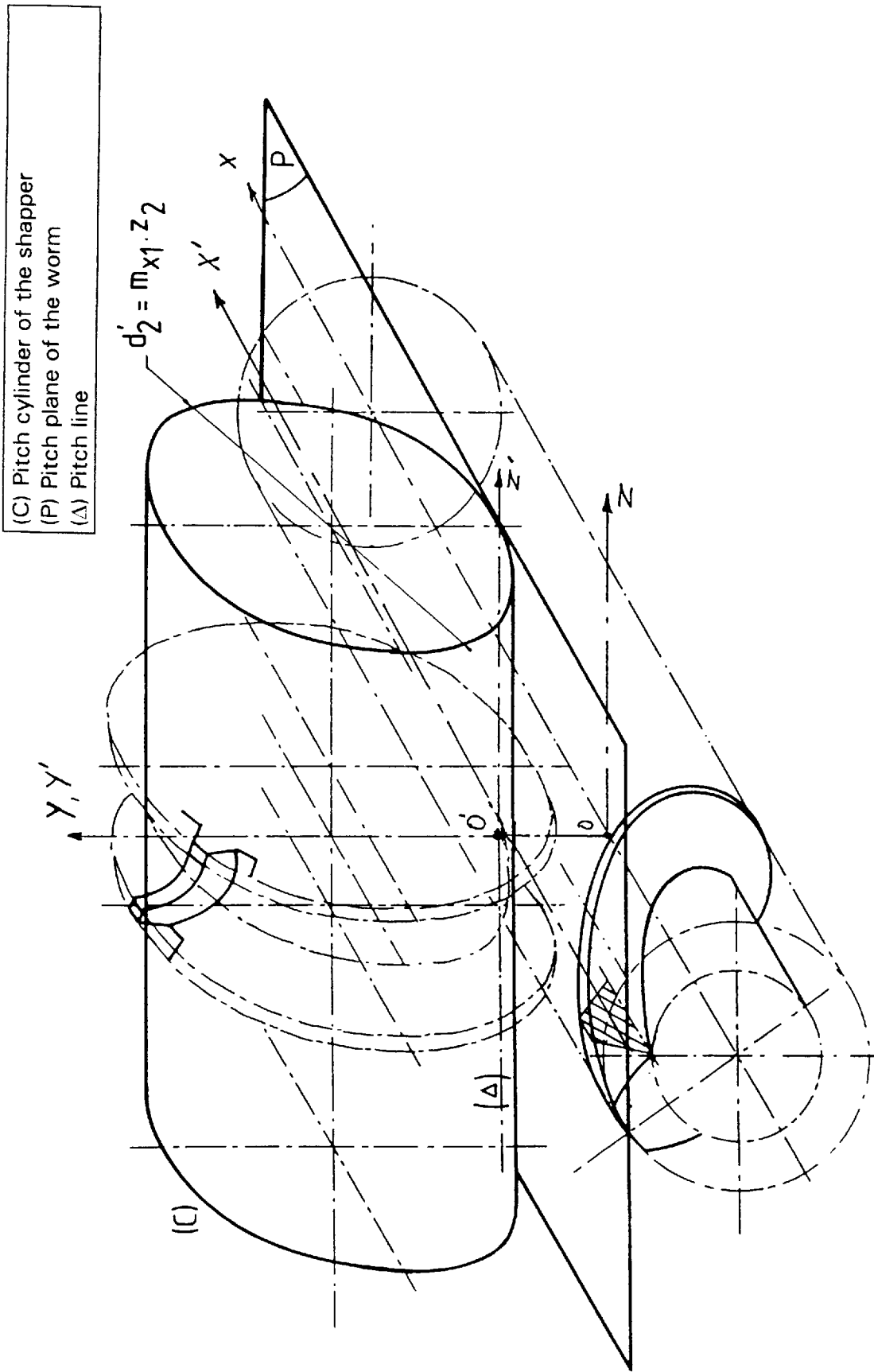

- (C) Pitch cylinder of the shaper
- (P) Pitch plane of the worm
- (Δ) Pitch line

Figure 1 : Conventions used in equations

4 Profiles

4.1 Type A

4.1.1 Geometrical definition

The thread flanks of type A are generated as envelopes of straight lines in axial planes which are inclined at a constant angle : $\frac{\pi}{2} - \alpha_{ot}$ to the axis. This line as it is moved with simultaneous rotation about and translation along the axis X, defines the worm thread flank (figure 2). The form of which is commonly described as an Archimedean helix.

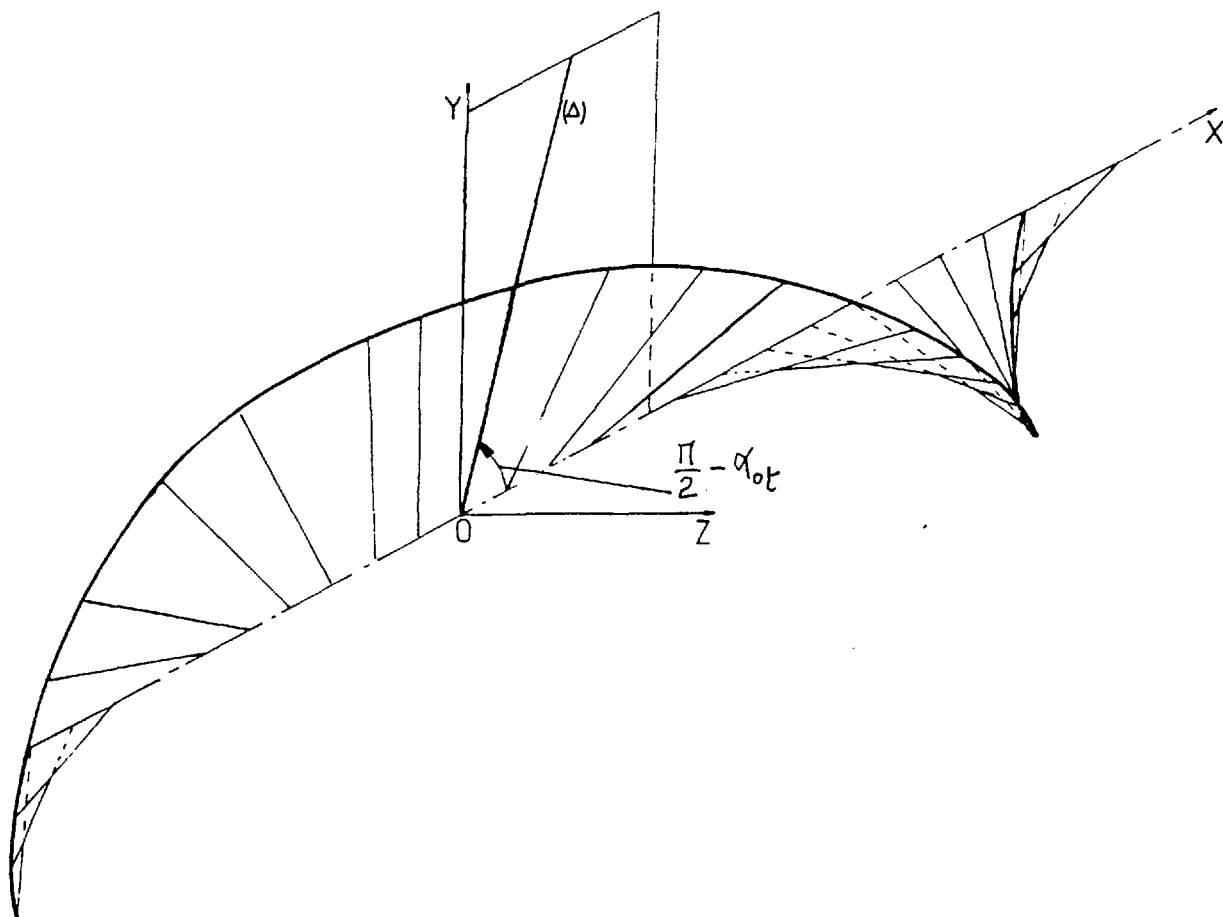

Figure 2 : Profile A : Theoretical Generation

4.1.2 Machining methods

The straight generatrix is always crossing the worm axis, the flank of thread in an axial plane is always a straight line ; so machining methods should ensure to generate this straight axial flank.

The threads may be cut on a lathe with a tool having straight edges, the cutting plane of which lies in an axial plane of the worm (figure 3 a)).

Both flanks of a thread space may be machined simultaneously by using a tool of trapezoidal form.

Another method which is an inversion of the process of cutting a helical gear with a rack cutter, involves the use of an involute shaper to produce the desired rectilinear rack profile in an axial plane of the worm. The cutting face must lie in that axial plane (figure 3 b)).

It is also necessary that the pitch circle of the shaper should roll without slip on the datum line of the rack profile. This coincides with a straight line generatrix of the worm pitch cylinder.

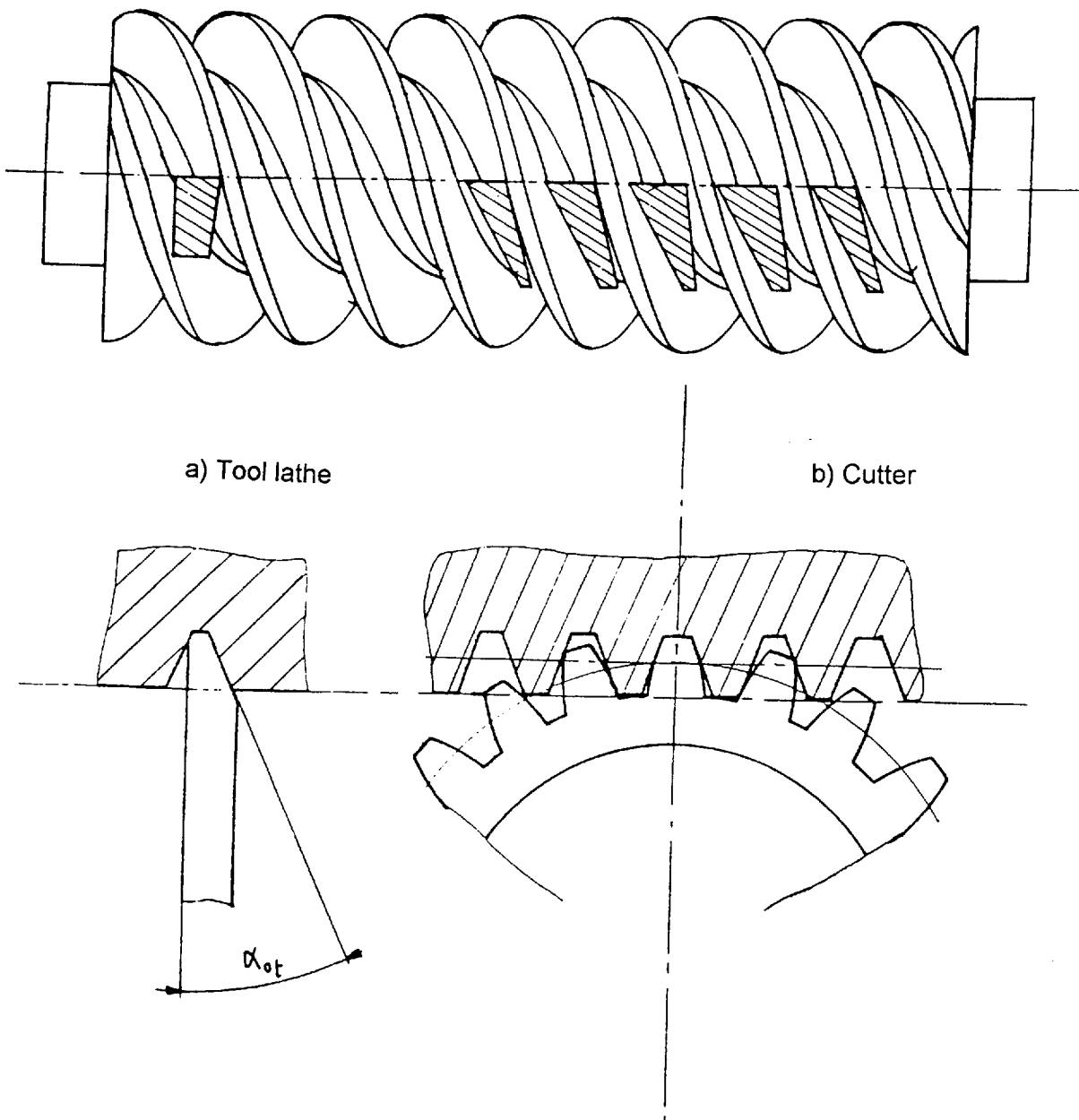

Figure 3 : Profile A- Machining Methods

4.1.3 Equations of the profile in the X-Y plane

Where :

α_{ot} is the transverse pressure angle of the cutter

α_{on} is the normal pressure angle of the cutter ;

γ_1 is the lead angle of threads.

For a point (x, y) at a distance y from the worm axis :

$$x_x = y_x \cdot \tan(\alpha_{or}) = y_x \cdot \tan(\alpha_{on}) / \cos(\gamma_1) \tag{1}$$

and

$$\tan(\alpha_x) = \tan(\alpha_{or}) \tag{2}$$

Type A profile is a straight line in any axial plane.

4.2 Type I

4.2.1 Geometrical definition

A flank of a type I worm is an involute helicoidal surface. The form of which may be generated by a base tangent (Δ) to a helix (H), which moves along this - the base helix lying on the base cylinder of the worm (C), which is concentric with the worm axis (figure 4).

A transverse profile (in a normal plane to the worm axis) of a flank is an involute to a circle.

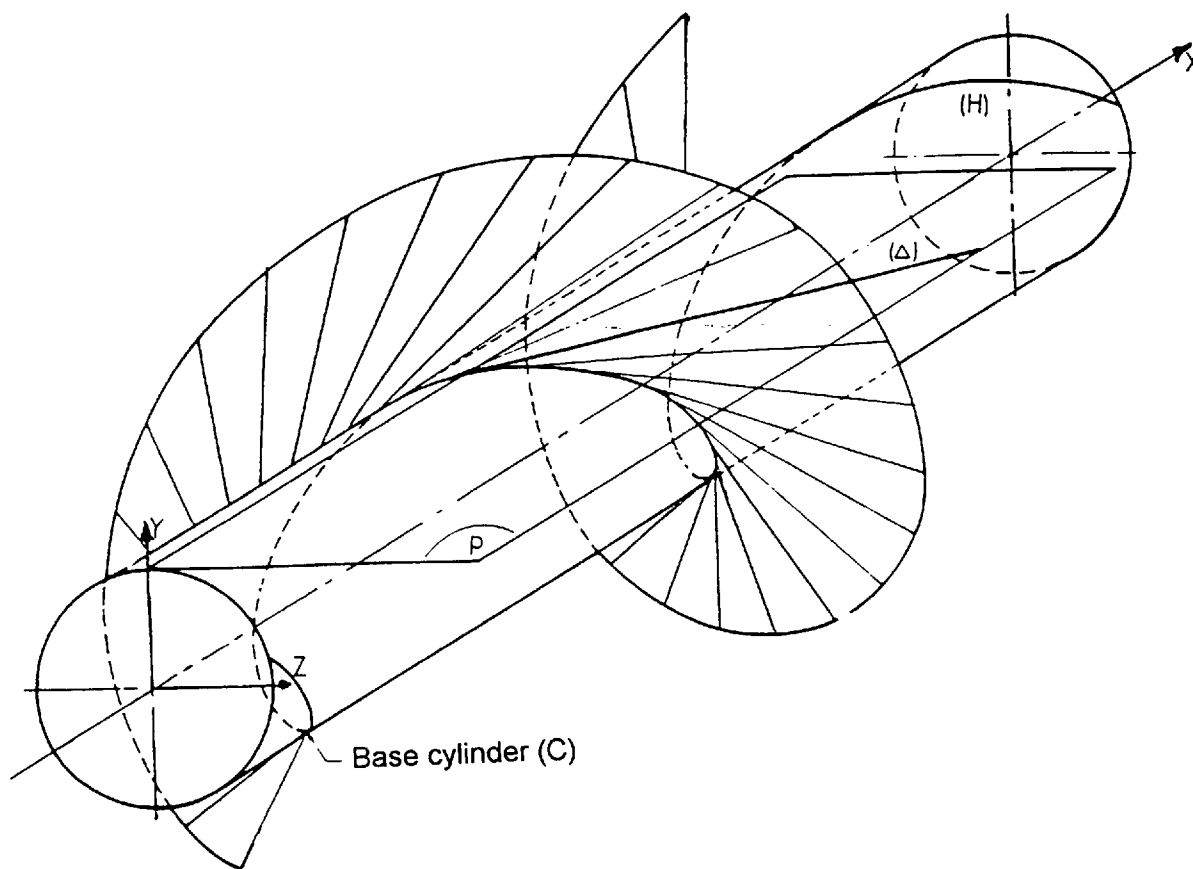

Figure 4 : Profile I - Theoretical generation

4.2.2 Machining methods

The straight generatrix is always tangential to the base helix in a plane which is tangential to the base cylinder, so the flank of the worm is a straight line in an offset plane which is tangential to the base cylinder. Machining methods should ensure this straight offset profile.

The involute helicoidal flanks of the threads can be generated by turning on a lathe using a knife tool with its straight edge aligned with the base tangent generatrix in a plane tangential to the base cylinder.

In order to machine both flanks of a thread simultaneously, it is necessary to set one left hand tool in one plane and one right hand tool in another plane as described above (figure 5).

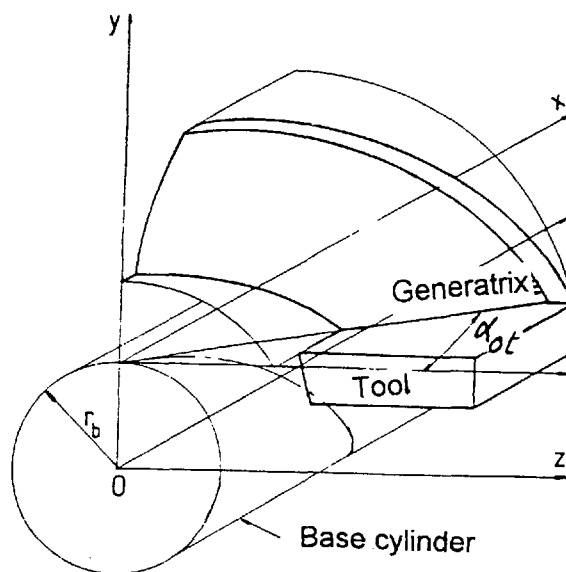

Figure 5 : Profile I - Machining method with a lathe

The thread flanks can be machined by milling or grinding using the plane side face of a disc type milling cutter or grinding wheel. The cutting face is to be so aligned that either its axis lies in a plane parallel to the X-Z plane and the base tangent generatrix of the flank lies in the cutting face (Figure 6); or the cutting face is aligned with the reference helix of the worm and in a plane perpendicular to the reference helix is set to the normal pressure angle of the flank α_{on} (figure 7).

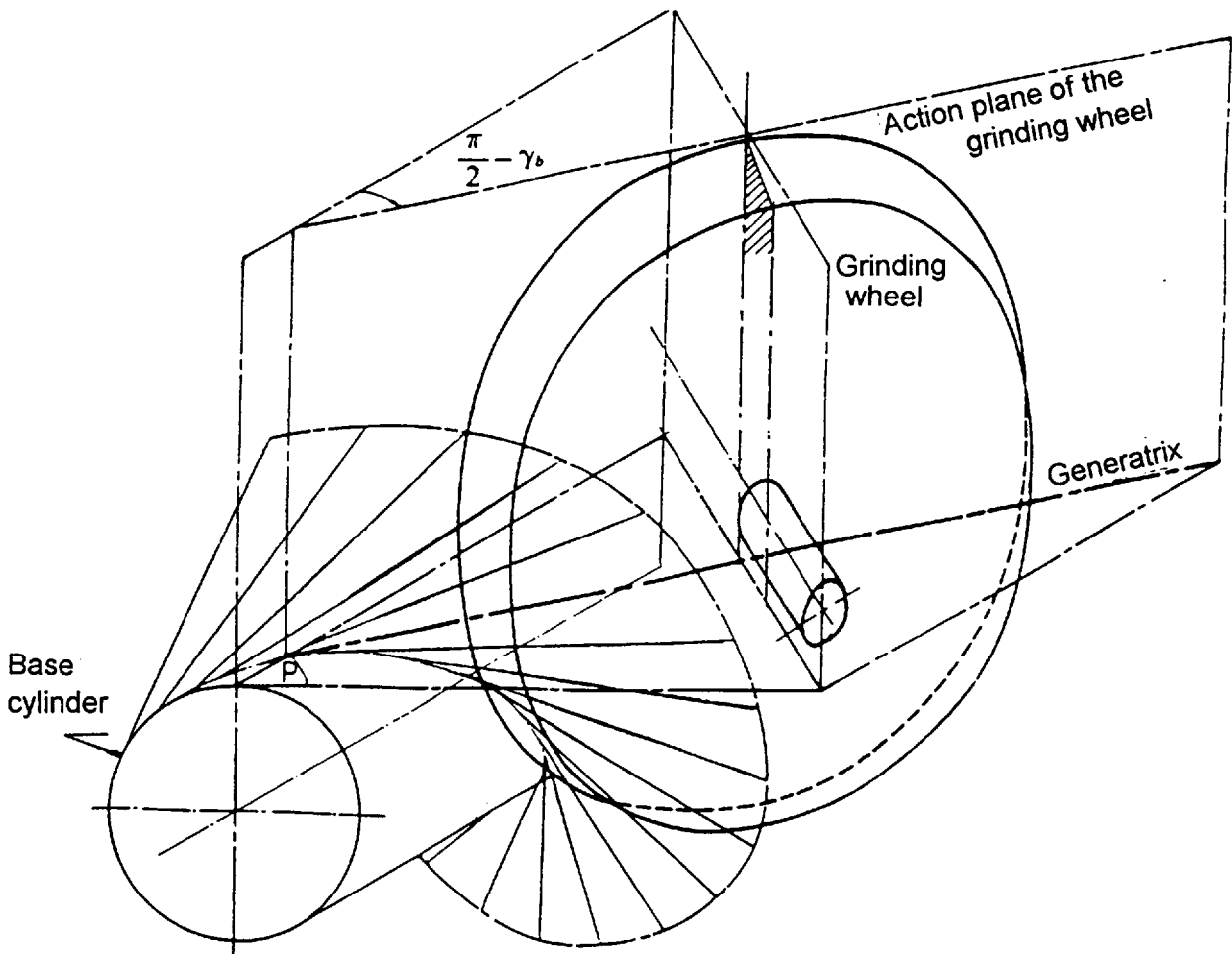

Figure 6 : Profile I - Machining method by grinding (solution 1)

The latter method of alignment has the advantage that the cutting face extends to near the thread root whereas in order to do so by the previous method it will be necessary raise the cutter/grinding-wheel spindle so that the cutter/wheel periphery is tangential to the point of intersection of the base tangent generatrix with the root cylinder of the worm.

Both methods require that the mounting of the worm in the milling/grinding machine must be reversed between machining right and left flanks.

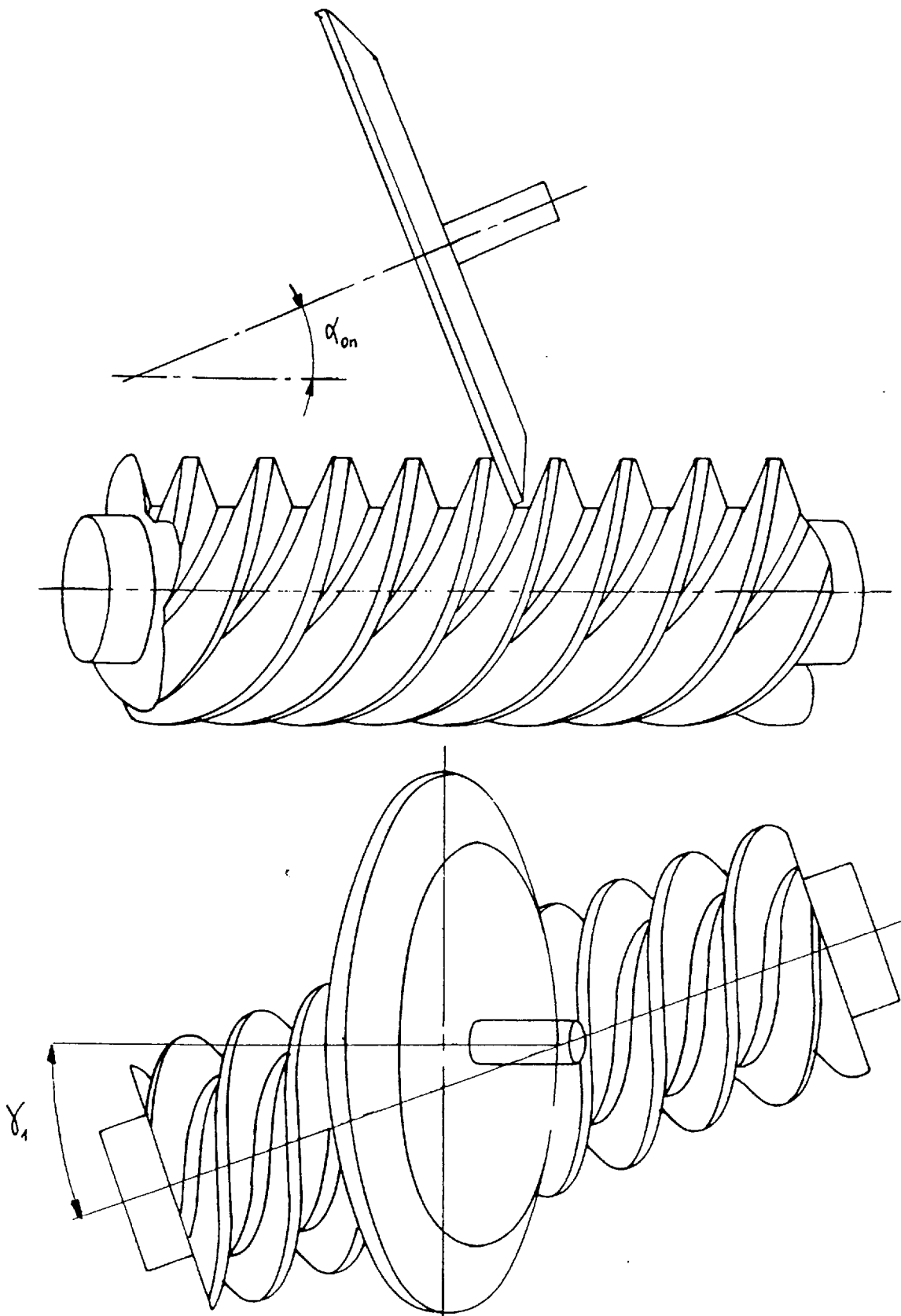

Figure 7 : Profile I - Machining method by grinding (solution 2)

4.2.3 Equations of the profile in the X-Y plane

Where :

- p_{z1} is the lead ;
- r_{b1} is the base radius ;
- γ_{b1} is the base lead angle ;
- γ_1 is the reference lead angle.

For a point (x_x, y_x) at a distance y from the worm axis :

$$x_x = \frac{p_{z1}}{2 \cdot \pi} \cdot \arctan \frac{\sqrt{y_x^2 - r_{b1}^2}}{r_{b1}} + \sqrt{y_x^2 - r_{b1}^2} \cdot \tan(\gamma_{b1}) \tag{3}$$

$$\tan(\alpha_x) = \frac{\sqrt{y_x^2 - r_{b1}^2}}{r_{b1}} \cdot \frac{p_{z1}}{2 \cdot \pi \cdot y_x} \tag{4}$$

$$r_{b1} = \frac{p_{z1}}{2 \cdot \pi \cdot \tan(\gamma_{b1})} \tag{5}$$

$$\cos(\gamma_{b1}) = \cos(\gamma_1) \cdot \cos(\alpha_{om}) \tag{6}$$

Type I axial profiles are slightly convex

4.3 Type N

4.3.1 Geometrical definition

Each flank of a type N worm is formed by a straight line generatrix (Δ) which lies in a plane normal to the reference helix (H_1), crossing (M) which is a common point of intersection of a vector radius, the generatrix (Δ) and the reference helix (H_1). The angle α between (Δ) and the radius vector at M point is constant.

The flank envelope is formed by the generatrix (Δ), due to the helicoidal movement of the vector radius carrying the point M which describes the reference helix (figure 8).

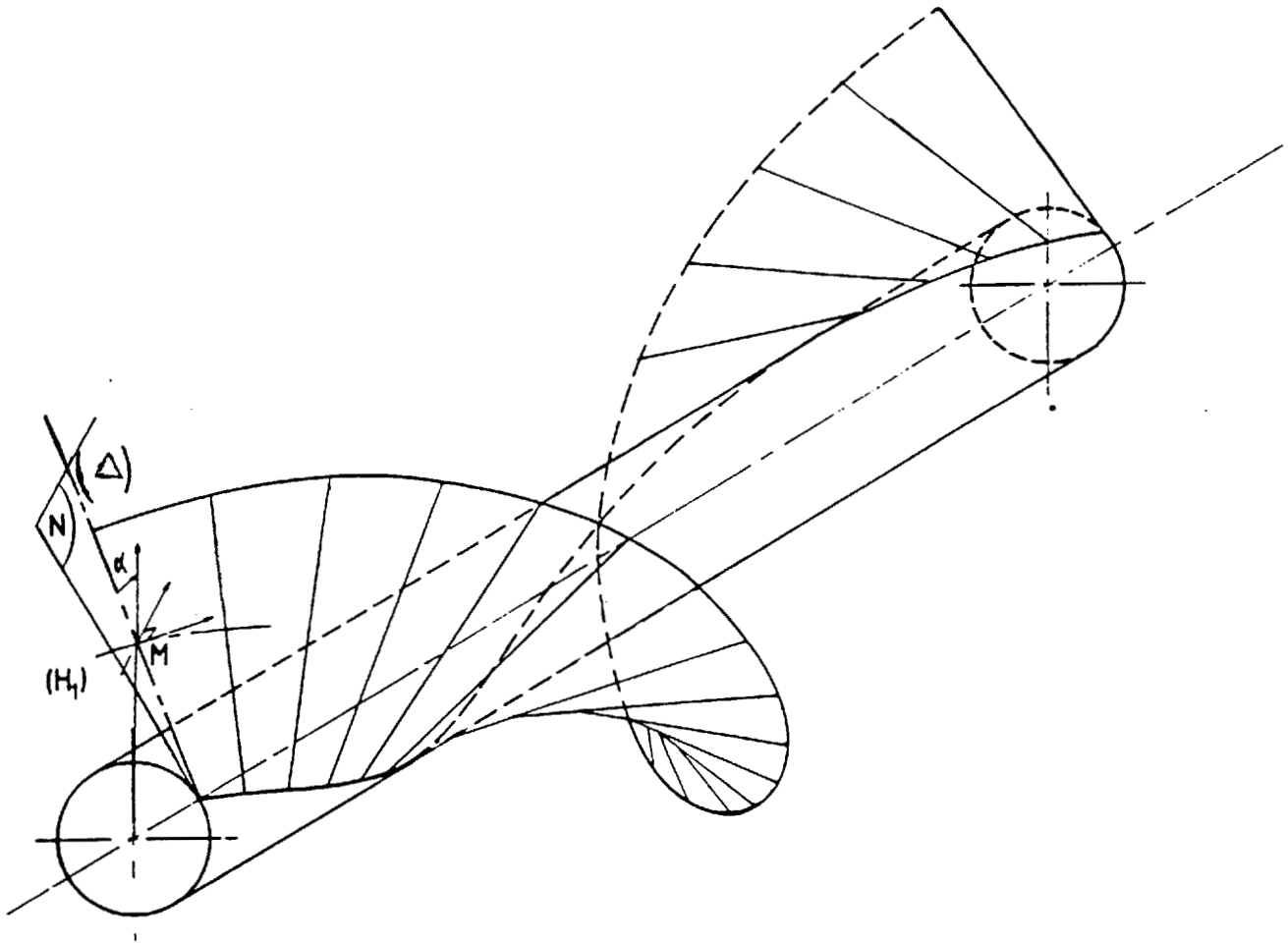

Figure 8 : Profile N - Theoretical generation

4.3.2 Machining methods

The threads may be cut in a lathe with a tool having trapezoidal form having edges in the cutting plane which match the profile of the thread space in a plane normal to the reference helix of the thread space.

This is equivalent to placing the tool as for A type threads, then to rotate it around an axis matching its symmetrical axis up to an angle equal to the reference lead angle γ_1 (figure 9 a)).

Other methods by which N type threads are approximated :

- using a biconical milling cutter or grinding wheel of small diameter (figure 9 b)). When the diameter of grinding wheel becomes large, the type of thread approaches K type ;
- using a small conical milling cutter or grinding wheel (figure 9 c)).

By the two latter methods, the profiles are approximate because of effects due to the change of helix with change of thread height.

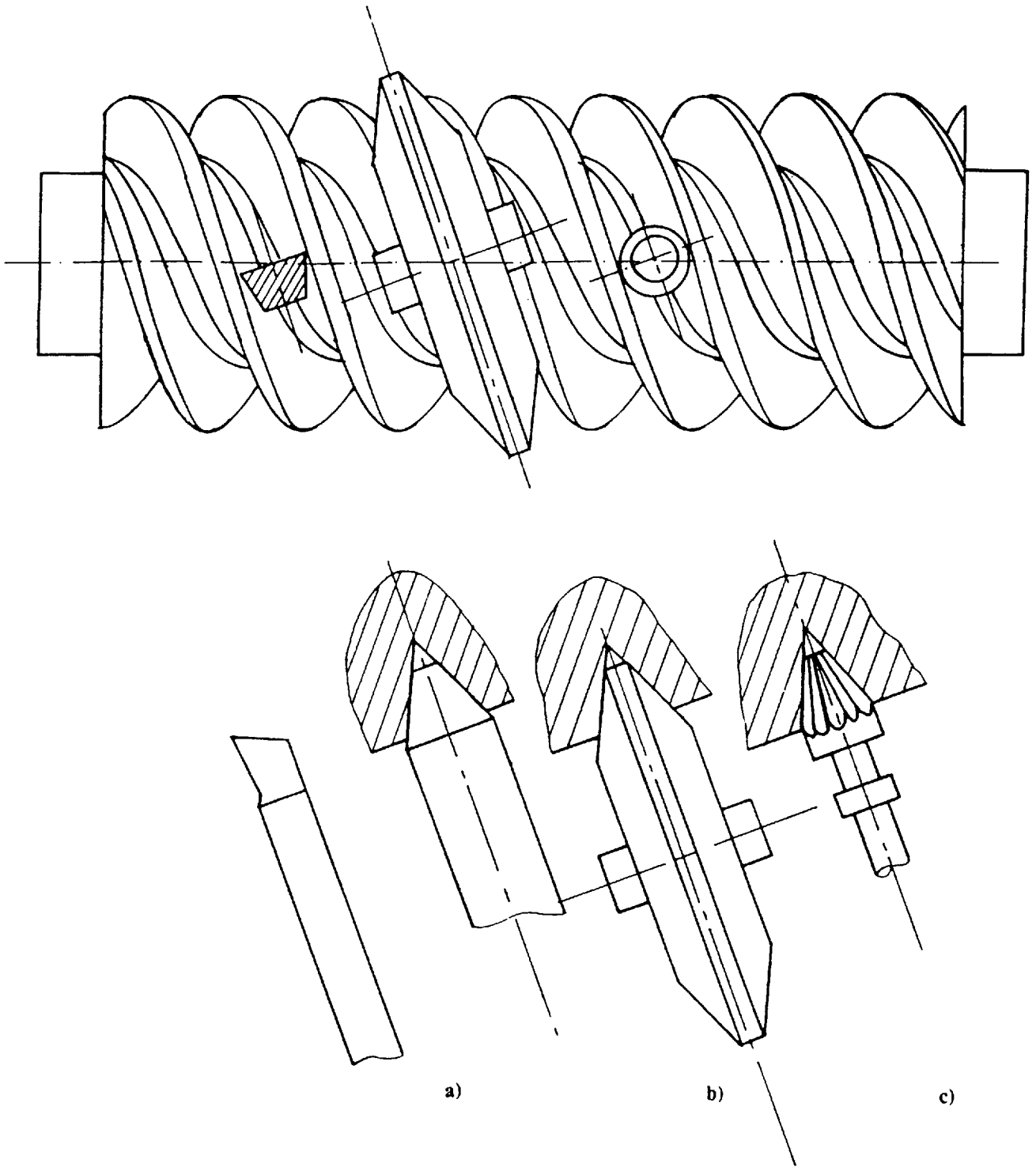

Figure 9 : Profile N - Machining methods

4.3.3 Equations of the profiles in the X-Y plane

Where :

- p_{x1} is the axial pitch ;
- p_{z1} is the lead ;
- r'_{b1} is the radius of a notional base circle ;
- γ'_{b1} is the lead angle of the notional base helix ;
- A is the distance from the worm axis to virtual point of the cutter (see ref.[1]) ;
- γ_1 is the lead angle of the reference helix ;
- α_{on} is the normal pressure angle of the cutter ;
- d_1 is the reference diameter of the worm.

For a point (x_x, y_x) at radial distance y from the worm axis :

$$x_x = \frac{p_{z1}}{2 \cdot \pi} \cdot \left\{ \arctan \left(\frac{\sqrt{y_x^2 - r_{b1}'^2}}{r_{b1}'} \right) - \theta \right\} + \sqrt{y_x^2 - r_{b1}'^2} \cdot \tan(\gamma'_{b1}) \quad (7)$$

with :

$$\theta = \arctan \left(\frac{\sqrt{A - r_{b1}'^2}}{r_{b1}'} \right) \quad (8)$$

$$\tan(\alpha_x) = \frac{p_{z1} \cdot r_{b1}' + 2 \cdot \pi \cdot y_x \cdot \tan(\gamma'_{b1})}{2 \cdot \pi \cdot y_x \sqrt{y_x^2 - r_{b1}'^2}} \quad (9)$$

where :

$$\tan(\gamma'_{b1}) = \frac{r_{b1}'}{A \cdot \tan(\gamma_1)} \quad (10)$$

$$r_{b1}' = \frac{A \cdot \sin(\gamma_1) \cdot \tan(\alpha_{on})}{\sqrt{1 - (\sin(\gamma_1) \cdot \tan(\alpha_{on}))^2}} \quad (11)$$

$$A = \frac{1}{2} \cdot \left(d_1 - p_{z1} \cdot \frac{\cos(\gamma_1)}{2 \cdot \tan(\alpha_{on})} \right) \quad (12)$$

Type N profiles are slightly concave in axial planes

4.4 Type K

4.4.1 Geometrical definition and method

Unlike those of types A, I and N, the thread flanks of type K worms do not have straight line generatrices. The thread spaces of type K worms are generated with a biconical grinding wheel or disc type milling cutter having straight cone generatrices (figure 10).

The common perpendicular to the tool spindle and worm axes lies in the line (Δ) of intersection of the median plane (M) of the tool and a transverse plane of the worm (R). The angle between the two planes is equal to the worm lead angle γ_1 . The straight generatrix of each tool cone and the median plane of the tool, forms an angle equal to the normal pressure angle α_{on} of the tool.

The worm is turned uniformly with simultaneous axial translation of threads so that a point on the common perpendicular, distant r_1 (r_1 : reference radius of worm) from the worm axis, describes the reference helix.

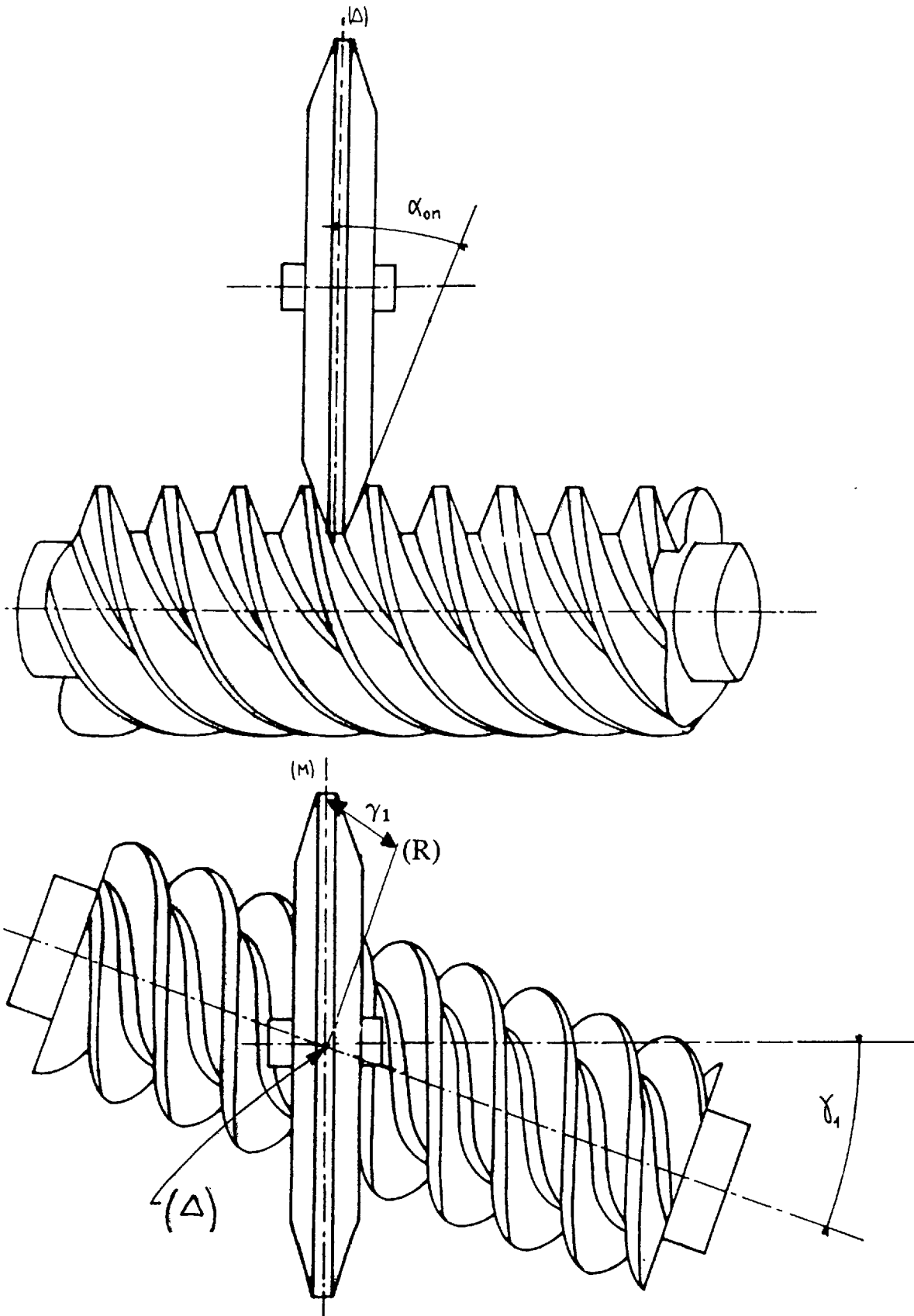

Figure 10 : Profile K - Machining method

The helicoidal flanks of the worm are generated by the conical sides of the tool and the profile form is influenced by the change of helix angle with change of thread height and points on the tool flanks which contact the worm threads lie on a curve and not on any one cone generatrix (figure 11).

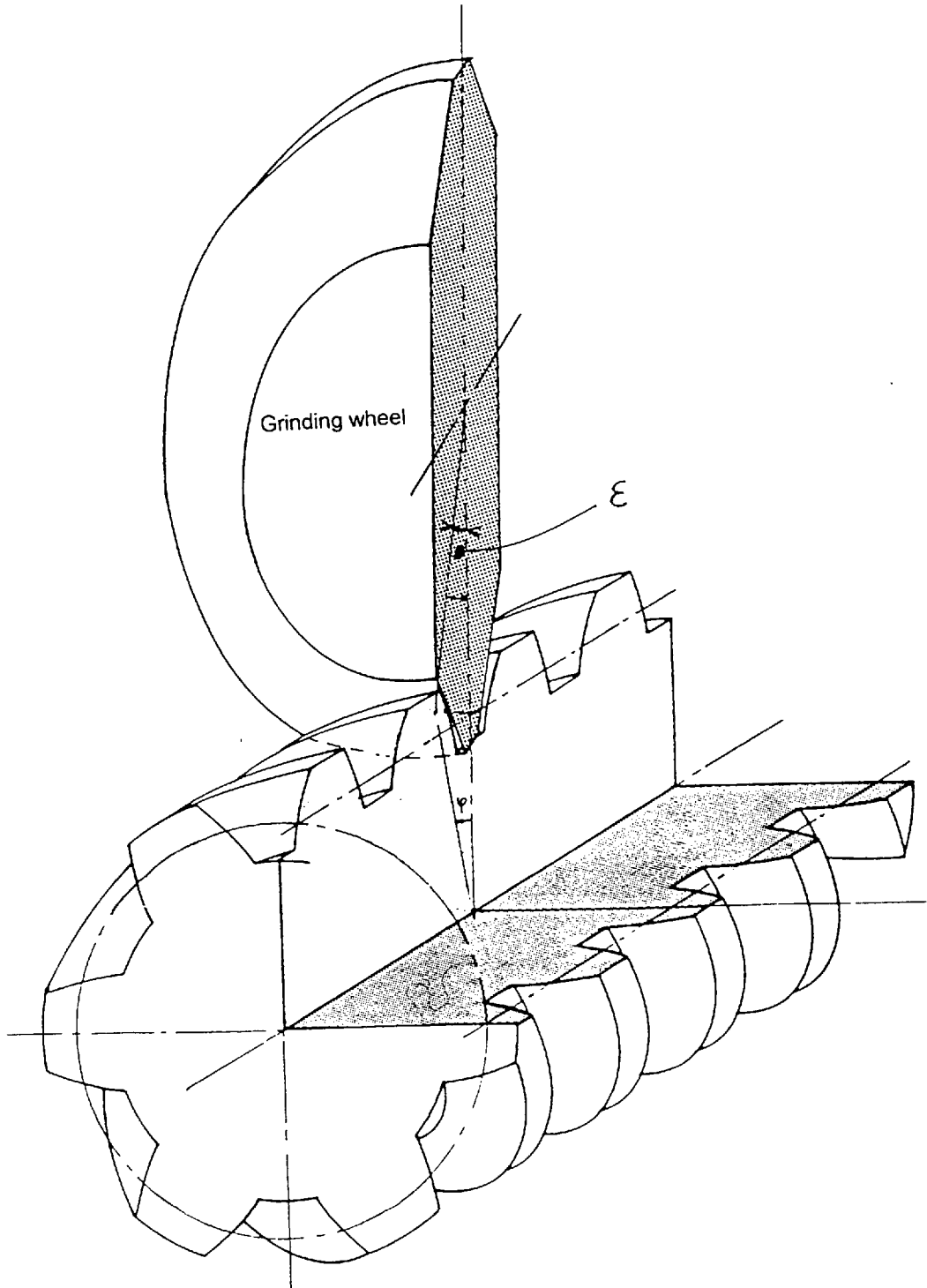

Figure 11 : Profile K - System of coordinates

4.4.2 Equations of the profiles in the X-Y plane

Where :

- C is the cutter spindle/worm centre distance ;
- γ_1 is the reference lead angle ;
- P_{z1} is the lead ;
- $(x_3, g(x_3))$ are the coordinates of a point on the tool flank when the origin is at the point of intersection of the tool axis and the tool median plane, with the x-axis as the tool spindle axis and the abscissae on the trace of the median plane ;
- d_1 reference diameter of the worm ;
- P_x axial pitch ;
- α_{on} normal pressure angle of the tool.

Determination of ε (figure 11)

ε is the angle between the axial plane of the disc tool which contains a point of contact between the tool and the worm thread flank, and the axial plane defined by the tool spindle axis and its common perpendicular with the worm axis.

$$b_1 = C \cdot \cos(\gamma_1) + \frac{P_{z1}}{2 \cdot \pi} \cdot \sin(\gamma_1) \tag{13}$$

$$b_2 = \sin(\gamma_1) \cdot \{x_3 + g(x_3) \cdot g'(x_3)\} \tag{14}$$

$$b_3 = g'(x_3) \cdot \left\{ C \cdot \sin(\gamma_1) - \frac{P_{z1}}{2 \cdot \pi} \cdot \cos(\gamma_1) \right\} \tag{15}$$

$$\varepsilon = \arcsin\left(\frac{b_3}{\sqrt{b_1^2 + b_2^2}}\right) - \arctan\left(\frac{b_2}{b_1}\right) \tag{16}$$

Determination of the coordinates (x_x, y_x) of a point in an axial profile of a worm thread flank :

Φ is the angle between an axial plane of the worm through a point of worm/disc- tool contact and the X-Y plane.

$$\Phi = \arctan\left(\frac{x_3 \cdot \sin(\gamma_1) + g(x_3) \cdot \cos(\gamma_1) \cdot \sin(\varepsilon)}{g(x_3) \cdot \sin(\gamma_1) - C}\right) - \arctan\left(\frac{u}{v}\right) \tag{17}$$

$$x_x = x_3 \cdot \cos(\gamma_1) - g(x_3) \cdot \sin(\gamma_1) \cdot \sin(\varepsilon) - \Phi \cdot \frac{P_{z1}}{2 \cdot \pi} \tag{18}$$

$$y_x = \frac{C - g(x_3) \cdot \cos(\varepsilon)}{\cos(\Phi)} \tag{19}$$

Determination of the tangent to the profile :

$$\tan(\alpha_x) = \frac{\frac{dx_x}{dx_3}}{\frac{dy_x}{dx_3}} \tag{20}$$

$$\frac{dx_x}{dx_3} = \cos(\gamma_1) - \sin(\gamma_1) \cdot \left\{ g'(x_3) \cdot \sin(\varepsilon) + g(x_3) \cdot \cos(\varepsilon) \cdot \frac{d\varepsilon}{dx_3} \right\} - \frac{p_{z1}}{2 \cdot \pi} \cdot \frac{d\Phi}{dx_3} \tag{21}$$

and :

$$\frac{dy_x}{dx_3} = \frac{1}{\cos(\gamma_1)} \cdot \left\{ g(x_3) \cdot \sin(\varepsilon) \cdot \frac{d\varepsilon}{dx_3} - g'(x_3) \cdot \cos(\varepsilon) + y_x \cdot \sin(\Phi) \cdot \frac{d\Phi}{dx_3} \right\} \tag{22}$$

$$\frac{d\Phi}{dx_3} = \frac{1}{y_3} \cdot \{ u' \cdot \cos(\Phi) - v' \cdot \sin(\Phi) \} \tag{23}$$

also

$$u' = \sin(\gamma_1) + \cos(\gamma_1) \cdot \left\{ g'(x_3) \cdot \sin(\varepsilon) + g(x_3) \cdot \cos(\varepsilon) \cdot \frac{d\varepsilon}{dx_3} \right\} \tag{24}$$

$$v' = g'(x_3) \cdot \cos(\varepsilon) - g(x_3) \cdot \sin(\varepsilon) \cdot \frac{d\varepsilon}{dx_3} \tag{25}$$

$$\frac{d\varepsilon}{dx_3} = \left(\frac{db_3}{dx_3} - \frac{db_2}{dx_3} \cdot \frac{b_2 \cdot b_3}{b_1^2 + b_2^2} \right) \cdot \frac{1}{\sqrt{b_1^2 + b_2^2 - b_3^2}} - \frac{b_1}{b_1^2 + b_2^2} \cdot \frac{db_2}{dx_3} \tag{26}$$

where :

$$\frac{db_2}{dx_3} = \sin(\gamma_1) \cdot \left\{ 1 + g'(x_3)^2 + g(x_3) \cdot g'(x_3) \right\} \tag{27}$$

$$\frac{db_3}{dx_3} = g''(x_3) \cdot \left\{ C \cdot \sin(\gamma_1) - \frac{p_{z1}}{2 \cdot \pi} \cdot \cos(\gamma_1) \right\} \tag{28}$$

NOTE : The previous equations apply to any profile of disc type tool.

Equations of the profile of a biconical grinding wheel (figure 12) :

$$g(x_3) = -\frac{1}{\tan(\alpha_{on})} \cdot x_3 + R_p \tag{29}$$

with : R_p is the radius of the circle of intersection of both conical surfaces.

$$R_p = C - \frac{d_1}{2} + \frac{p_{x1}}{4} \cdot \frac{\cos(\gamma_i)}{\tan(\alpha_{on})} \tag{30}$$

from which :

$$g'(x_3) = -\frac{1}{\tan(\alpha_{on})} \tag{31}$$

$$g''(x_3) = 0 \tag{32}$$

Like type I profile, profile K is convex in axial planes.

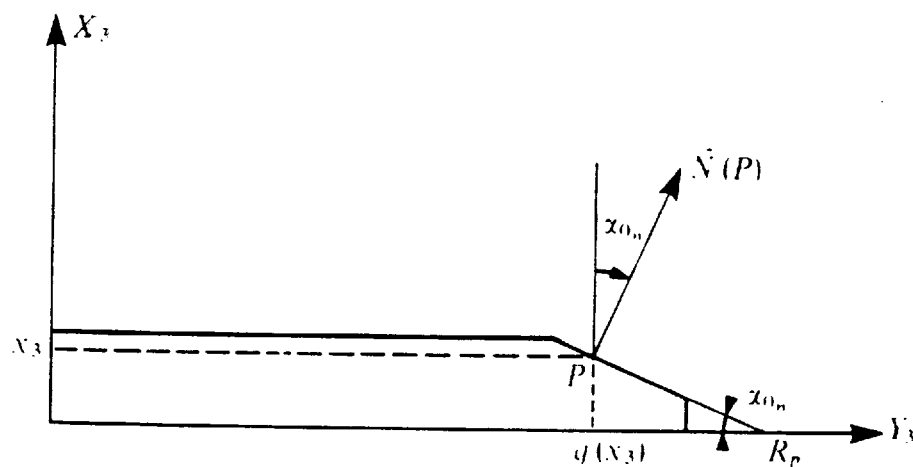

Figure 12 : Profile K - Grinding wheel profile

One of the advantages of this type is that the two flanks of a thread space can be machined simultaneously.

A disadvantage is that the form of the thread flanks varies with tool diameter, so the reproducibility is approximated.

NOTE 1 : The smaller the diameter of the tool, the more nearly the normal profiles of the thread spaces approach those of type N worms and the larger the tool diameter the more nearly the forms of the thread flanks approach those of type I worms.

NOTE 2 : It is possible to machine type K worms with a conical milling cutter. The flank surfaces have facets resulting from the cutting discontinuity caused by cutting tooth pitch.

4.5 Type C

4.5.1 Geometrical definition

Unlike those of types A, I and N, the thread flanks of type C worms do not have straight line generatrices.

Like type K worms, the thread spaces of type C worms are generated with a grinding wheel or disc type milling cutter. In order to produce the concave thread profiles of type C worms, the tool has a cutting profile consisting of convex circular arcs. Figure 13 shows a tool and worm with the system of coordinates for the worm (x, y, z) and for the tool (x_w, y_w, z_w).

The length of the line of centres C_s (the common perpendicular to the worm and tool axes X_w and X) varies with the tool diameter. The reference lead angle γ_l is usually equal to the angle between the projections of these axes onto a plane perpendicular to the line of centres. Figure 13 shows partially the tool. The 4 tool dimensions which determine the thread form of the worm are: the profile radius ρ , the mean diameter d_{ms} of the tool profile, the tool pressure angle α_{on} and the tool thickness w .

The process of generating the worm C profiles is the same as for type K (see 3.4.1).

The thread flank profile form varies a little with a change of tool diameter.

However in contrast to type K thread profiles, type C thread profiles can be adjusted to compensate change of tool diameter by modifying the ρ and the angle α_{on} of the tool.

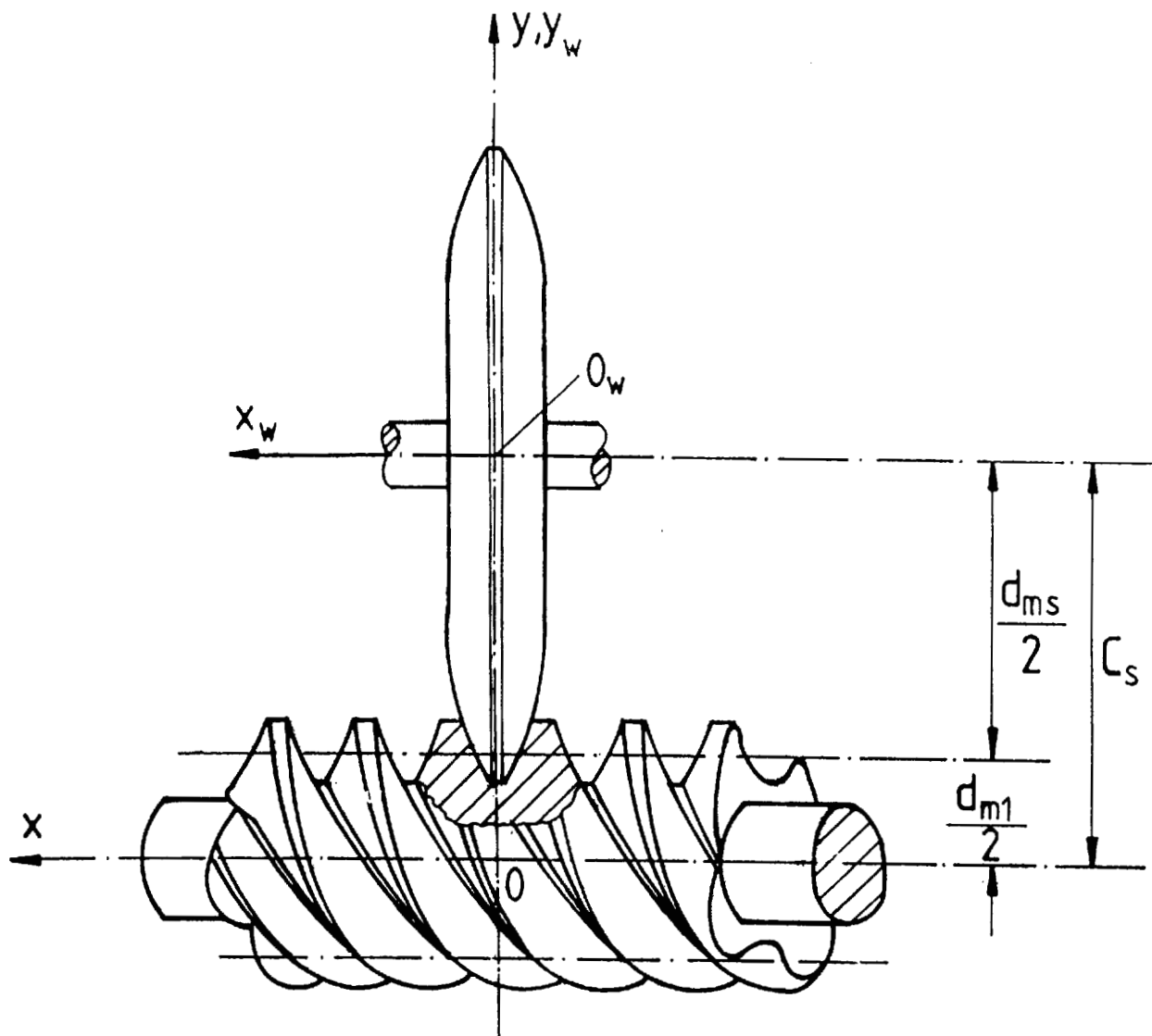

Figure 13a : Profile C - System of coordinate

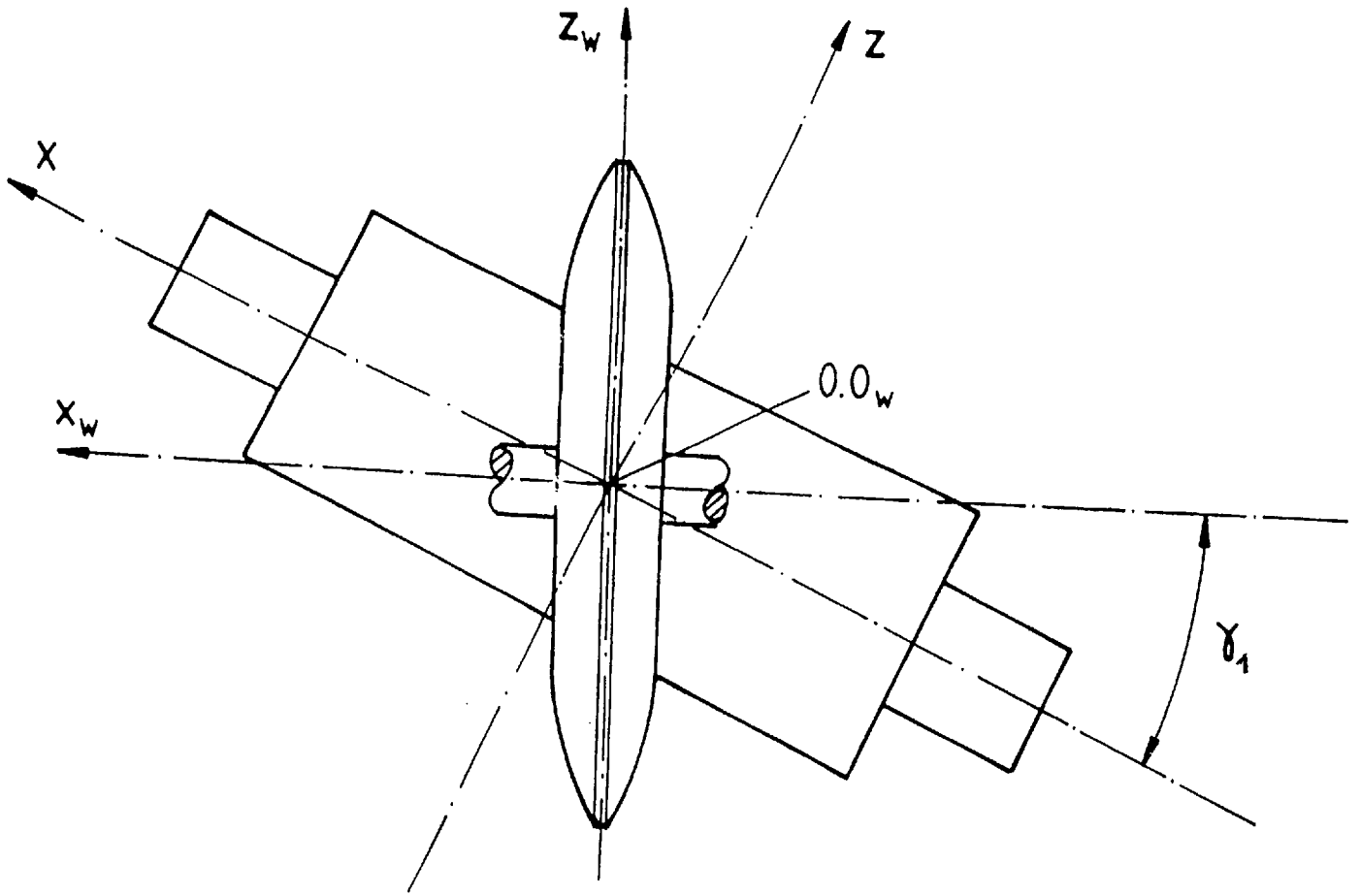

Figure 13b : Profile C - System of coordinate

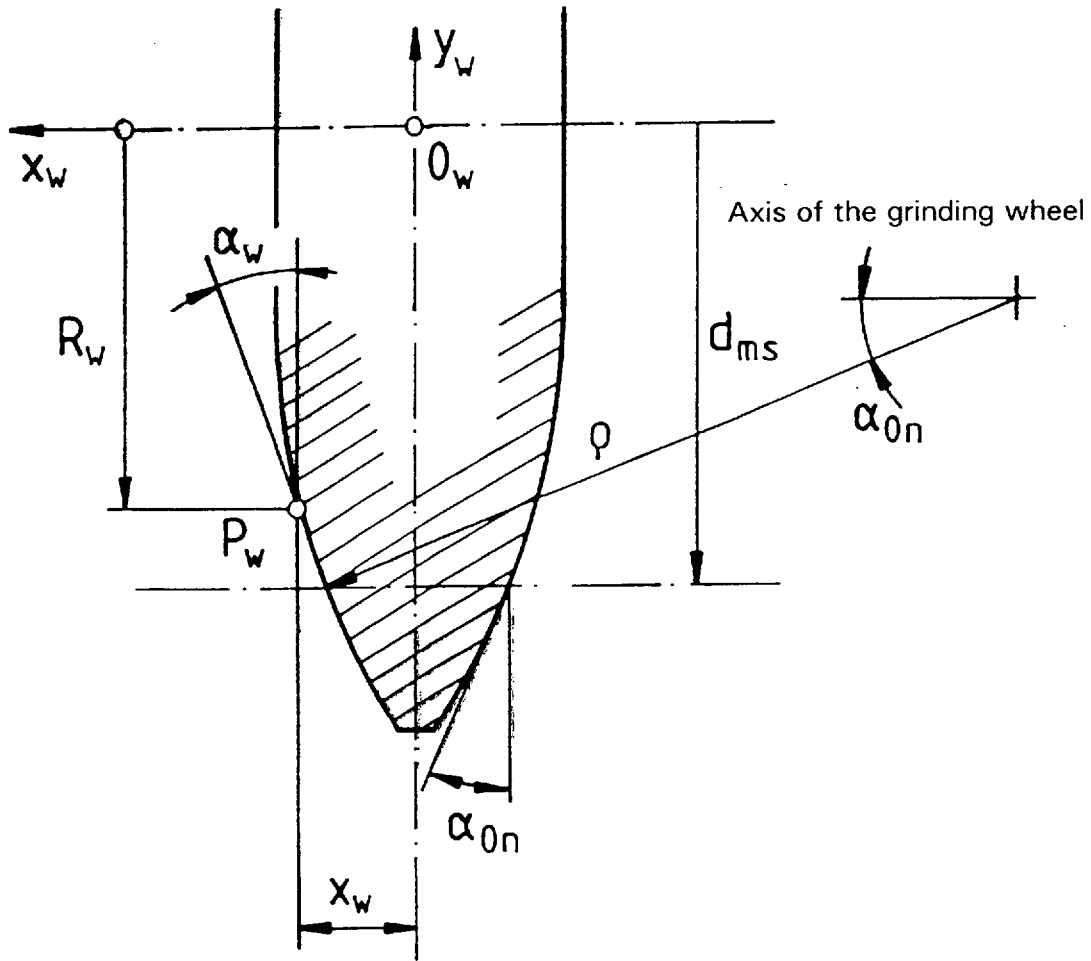

Figure 14 : Profile C - Axial section of the tool

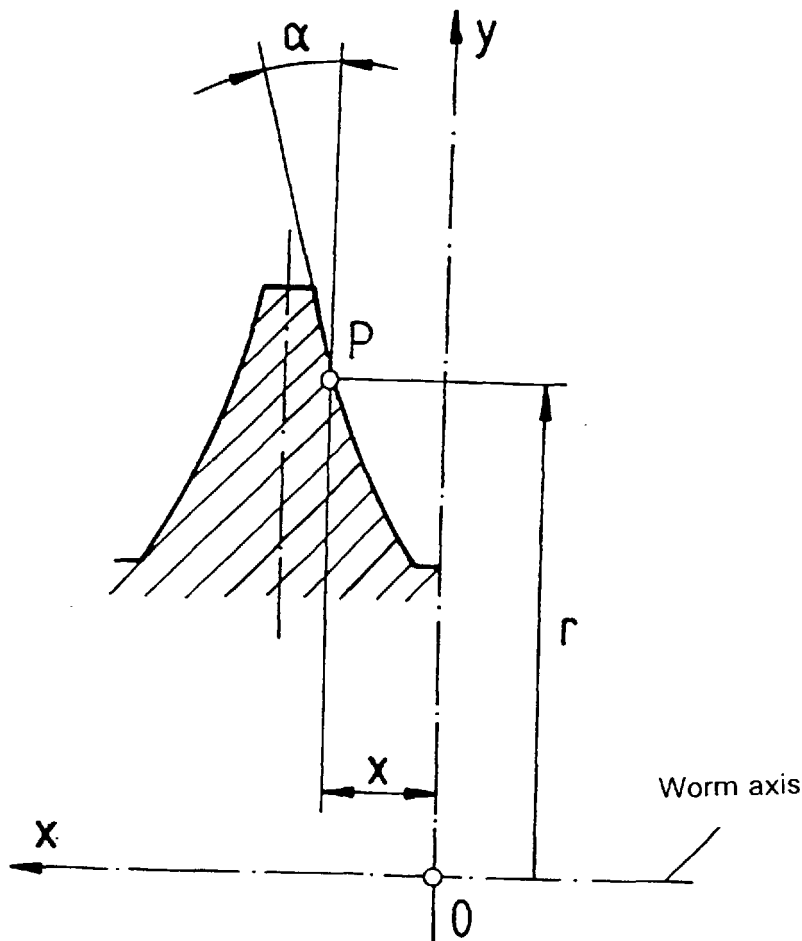

Figure 15 : Profile C - Axial section of the worm

Equations enabling determination of the axial sections of worms

With the basic data of the tool indicated in figure 13, the parameters R_w , x_w and α_w may be derived for any point P_w of the tool profile.

On the basis of these three parameters and with the equations provided below, the coordinates x , r , of an axial profile and the angle α of the tangent may be determined for any point P of the profile of a worm.

Symbols :

- C_s refers to the worm/tool centre distance (length of the common perpendicular to the worm/tool axes) ;
- p_{z1} refers to the lead of the worm threads ;

γ_1 refers to the thread angle ;

R_w, x_w, α_w see figure 14 ;

x, r, α see figure 15.

$$K = -C_s + \frac{p_{z1}}{2 \cdot \pi \cdot \tan(\gamma_1)} \quad (33)$$

$$K_1 = \frac{C_s \cdot \tan(\alpha_w)}{\tan(\gamma_1)} + \frac{p_{z1}}{2 \cdot \pi} \cdot \tan(\alpha_w) \quad (34)$$

$$K_2 = -R_w + x_w \cdot \tan(\alpha_w) \quad (35)$$

$$K_3 = \sqrt{K_1^2 + K_2^2} \quad (36)$$

$$K_4 = \arctan\left(\frac{K_2}{K_1}\right) \quad (37)$$

$$K_5 = \arcsin\left(\frac{K}{K_3}\right) - K_4 \quad (38)$$

$$K_7 = C_s - R_w \cdot \cos(K_5) \quad (39)$$

$$K_8 = -\cos(\gamma_1) \cdot \{R_w \cdot \sin(K_5) + x_w \cdot \tan(\gamma_1)\} \quad (40)$$

$$K_6 = \arctan\left(\frac{K_8}{K_7}\right) \text{ also } \frac{K_8}{K_7} \Rightarrow K_6 \quad (41)$$

$$r = \sqrt{K_7^2 + K_8^2} \quad (42)$$

$$x_1 = x_w \cdot \cos(\gamma_1) - R_w \cdot \sin(K_5) \cdot \sin(\gamma_1) \quad (43)$$

$$x = x_1 - \frac{p_{z1}}{2 \cdot \pi} \cdot K_6 \quad (44)$$

$$K_z = -\sin(\gamma_1) - \cos(\gamma_1) \cdot \tan(\alpha_w) \cdot \sin(K_5) \quad (45)$$

$$K_x = \cos(\gamma_1) - \sin(\gamma_1) \cdot \tan(\alpha_w) \cdot \sin(K_5) \quad (46)$$

$$K_y = -\tan(\alpha_w) \cdot \cos(K_5) \quad (47)$$

$$K_o = K_z \cdot \sin(K_6) + K_y \cdot \cos(K_6) \quad (48)$$

$$\alpha = \arctan\left(-\frac{K_o}{K_x}\right) \text{ also } -\frac{K_o}{K_x} \Rightarrow \alpha \quad (49)$$

5 Projection Planes

Projection planes referred to in this report (figure 16).

5.1 Axial plane

The axial plane is the plane containing the worm axis and the X and Y axes of the coordinate system.

5.2 Offset plane

An offset plane is parallel to the X-Y plane at an offset D (Z axis).

A point in the offset plane is determined by the point of intersection with that plane of the helix through a reference point x, y , in X-Y plane.

5.3 Transverse plane

A transverse plane is a plane which is perpendicular to the axis of worm.

5.4 Normal plane

A normal plane is defined as a plane which is perpendicular to the reference helix crossing the symmetrical axes of the complete axial profile (left and right flank).

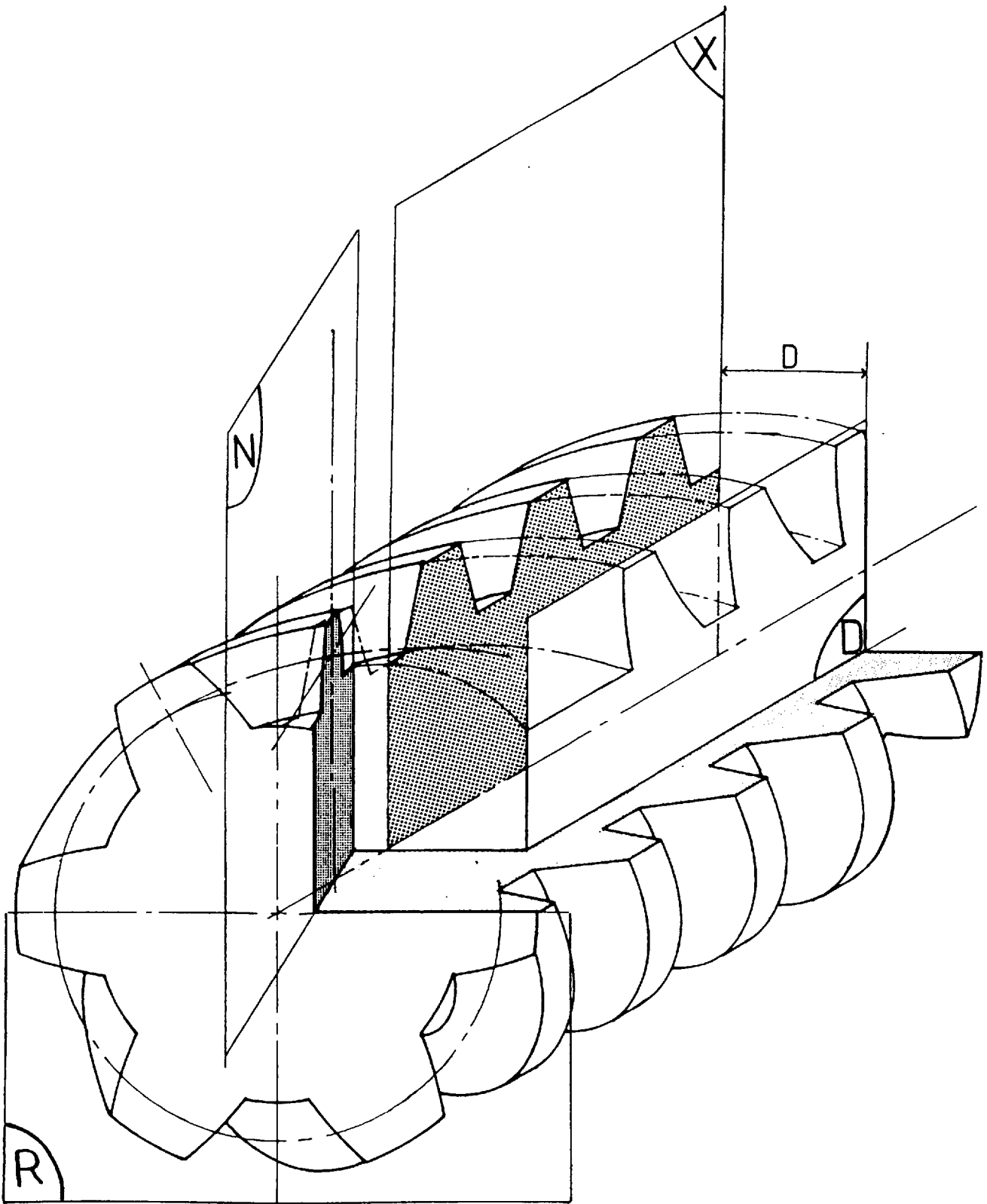

Figure 16 : Projection planes

Annex A

Bibliography

- [1] DENIS and OCTRUE: Note technique CETIM n° 22, *Géométrie des roues et vis tangentés*, Ed. CETIM, Senlis, France, 1982

ICS 21.200

Descriptors: gears, worm gears, geometric characteristics, profiles.

Price based on 20 pages
