

INTERNATIONAL STANDARD

ISO 9997

Second edition
1999-12-15

Dental cartridge syringes

Seringues à usage dentaire pour cartouches



Reference number
ISO 9997:1999(E)

© ISO 1999

PDF disclaimer

This PDF file may contain embedded typefaces. In accordance with Adobe's licensing policy, this file may be printed or viewed but shall not be edited unless the typefaces which are embedded are licensed to and installed on the computer performing the editing. In downloading this file, parties accept therein the responsibility of not infringing Adobe's licensing policy. The ISO Central Secretariat accepts no liability in this area.

Adobe is a trademark of Adobe Systems Incorporated.

Details of the software products used to create this PDF file can be found in the General Info relative to the file; the PDF-creation parameters were optimized for printing. Every care has been taken to ensure that the file is suitable for use by ISO member bodies. In the unlikely event that a problem relating to it is found, please inform the Central Secretariat at the address given below.

© ISO 1999

All rights reserved. Unless otherwise specified, no part of this publication may be reproduced or utilized in any form or by any means, electronic or mechanical, including photocopying and microfilm, without permission in writing from either ISO at the address below or ISO's member body in the country of the requester.

ISO copyright office
Case postale 56 • CH-1211 Geneva 20
Tel. + 41 22 749 01 11
Fax + 41 22 734 10 79
E-mail copyright@iso.ch
Web www.iso.ch

Printed in Switzerland

Contents

Page

Foreword.....	iv
Introduction.....	v
1 Scope	1
2 Normative references	1
3 Terms and definitions	1
4 Classification.....	2
5 Requirements	2
5.1 General.....	2
5.2 Materials	3
5.3 Dimensions.....	3
6 Test methods.....	3
6.1 Visual inspection	3
6.2 Aspirating test for syringes of Type 2a	3
6.3 Aspirating test for syringes of Type 2b	4
6.4 Plunger rod tests	4
6.5 Boiling water test for corrosion	6
6.6 Autoclave test for corrosion	6
6.7 Thermal test (metal syringes only)	6
7 Information supplied by the manufacturer.....	6
8 Marking	6
8.1 Marking of unit pack.....	6
8.2 Marking of syringe.....	6
Annex A (informative) Imperial thread size.....	7

Foreword

ISO (the International Organization for Standardization) is a worldwide federation of national standards bodies (ISO member bodies). The work of preparing International Standards is normally carried out through ISO technical committees. Each member body interested in a subject for which a technical committee has been established has the right to be represented on that committee. International organizations, governmental and non-governmental, in liaison with ISO, also take part in the work. ISO collaborates closely with the International Electrotechnical Commission (IEC) on all matters of electrotechnical standardization.

International Standards are drafted in accordance with the rules given in the ISO/IEC Directives, Part 3.

Draft International Standards adopted by the technical committees are circulated to the member bodies for voting. Publication as an International Standard requires approval by at least 75 % of the member bodies casting a vote.

Attention is drawn to the possibility that some of the elements of this International Standard may be the subject of patent rights. ISO shall not be held responsible for identifying any or all such patent rights.

International Standard ISO 9997 was prepared by Technical Committee ISO/TC 106, *Dentistry*, Subcommittee SC 4, *Dental instruments*.

This second edition cancels and replaces the first edition (ISO 9997:1990), which has been technically revised as follows:

- the dental cartridge syringes are now classified into non-aspirating and aspirating types with a subclassification according to aspiration of force produced by drawing the plunger or by the deflection of a diaphragm;
- improved description of plunger rod test;
- corrosion test in accordance with ISO 13402;
- marking now requires lot number.

Introduction

This International Standard specifies requirements for dental cartridge syringes with ISO metric thread sizes only. However, attention is drawn to the existence of a variety of syringes with Imperial thread sizes (see annex A).

Dental cartridge syringes

1 Scope

This International Standard specifies requirements and test methods for dental cartridge syringes which are reusable dental syringes of the aspirating, non-aspirating and self-aspirating types using cartridges with dental local anaesthetics.

This International Standard is not applicable to cartridge syringes having a mechanical-advantage action for creating high pressure.

2 Normative references

The following normative documents contain provisions which, through reference in this text, constitute provisions of this International Standard. For dated references, subsequent amendments to, or revisions of, any of these publications do not apply. However, parties to agreements based on this International Standard are encouraged to investigate the possibility of applying the most recent editions of the normative documents indicated below. For undated references, the latest edition of the normative document referred to applies. Members of IEC and ISO maintain registers of currently valid International Standards.

ISO 261, *ISO general purpose metric screw threads — General plan.*

ISO 965-1, *ISO general purpose metric screw threads — Tolerances — Part 1: Principles and basic data.*

ISO 1942-3, *Dental vocabulary — Part 3: Dental instruments.*

ISO 11499, *Dental cartridges for local anaesthetics.*

ISO 13402:1995, *Surgical and dental hand instruments — Determination of resistance against autoclaving, corrosion and thermal exposure.*

3 Terms and definitions

For the purposes of this International Standard, the terms and definitions given in ISO 1942-3, ISO 11499 and the following apply.

3.1

aspiration

process by which blood or body fluid is drawn into an anaesthetic cartridge

3.2

unit pack

pack containing a dental cartridge syringe

3.3

cartridge

container for local anaesthetics

4 Classification

For the purposes of this International Standard, dental cartridge syringes are classified into the following types:

- Type 1: non-aspirating
- Type 2: aspirating
 - Type 2a: aspiration by force produced by drawing the plunger away from the needle
 - Type 2b: aspiration by force produced by the deflection of a diaphragm in the cartridge.

5 Requirements

5.1 General

General requirements for dental cartridges for local anaesthetics as specified in ISO 11499 shall be met.

5.1.1 Loading and cartridge size

The cartridge shall be capable of being loaded either from the side or from the back (breech type). The syringe shall permit the appropriate size of local anaesthetic cartridge to be securely held and incapable of being dislodged during use.

Testing shall be carried out in accordance with 6.1.

5.1.2 Viewing of contents

The syringe shall allow the solution for injection to be observed, including the result of aspiration.

Testing shall be carried out in accordance with 6.1, 6.2 and 6.3.

5.1.3 Plunger rod

The plunger rod shall satisfy test 6.4 before and after the tests in 6.5, 6.6 and 6.7.

The cartridge end of the plunger rod shall contain either a permanently attached tip or a means of securing various plunger tips supplied by the manufacturer of the cartridge syringe.

Testing shall be carried out in accordance with 6.1.

5.1.4 Aspirating syringes

5.1.4.1 General

Aspirating syringes shall permit aspiration at any time during use.

NOTE Some aspirating syringes are intended for use only with cartridges fitted with specially designed rubber plungers. These syringes may not aspirate when used with any other cartridges.

5.1.4.2 Syringes in which aspiration is achieved by moving the cartridge plunger away from the needle (Type 2a)

Testing shall be carried out using a cartridge complying with ISO 11499. After testing, the reagent (6.2.1) shall have been aspirated into the cartridge and the harpoon or threaded portion of the plunger rod shall not have disengaged.

Testing shall be carried out in accordance with 6.2.2.

5.1.4.3 Syringes in which aspiration is achieved by deflection of a diaphragm within the cartridge (Type 2b)

Use cartridges complying with ISO 11499. After testing, the reagent (6.2.1) shall have been aspirated into the cartridge.

Testing shall be carried out in accordance with 6.3.2.

5.2 Materials

5.2.1 Metal syringes

The parts shall be capable of withstanding repeated sterilization without impairing the function of the syringe and without showing signs of corrosion such as blemishes, pittings or discolouration.

Testing shall be carried out in accordance with 6.1 and 6.5 and subsequently 6.6 and 6.7.

5.2.2 Plastics syringes, including metal syringes with plastic parts

The material shall be capable of withstanding repeated sterilization without impairing the function of the syringe and without showing deterioration of the material of construction.

Testing shall be carried out in accordance with 6.1, 6.5 and subsequently 6.6.

Any metal part shall comply with the requirements of 5.2.1.

5.3 Dimensions

The dimensions shall be as specified in Figure 1 and the metric-threaded needle-mounting hub shall meet the requirements for screw threads in accordance with ISO 261 and ISO 965-1.

6 Test methods

6.1 Visual inspection

Visual inspection shall be conducted at normal visual acuity without magnification.

6.2 Aspirating test for syringes of Type 2a

6.2.1 Reagent

A coloured liquid, for example an aqueous solution of methylene blue, with a viscosity of 4 mPa·s (0,04 poise) at (23 ± 2) °C.

6.2.2 Procedure

Assemble the syringe, cartridge and needle of dimensions 0,4 mm × 35 mm. Fix the harpoon or threaded portion of the working end of the plunger rod to the plunger of the local anaesthetic cartridge in accordance with the manufacturer's instructions. Immerse the needle in the coloured liquid (6.2.1) and depress the plunger for 5 mm at a rate of 5 mm/s and then, at the same rate, withdraw the plunger until the reagent appears in the cartridge or for a maximum distance of 5 mm. Repeat the test three times with the same local anaesthetic cartridge.

6.2.3 Observation

Observe whether the requirement of 5.1.4.2 is fulfilled after each withdrawal of the plunger.

6.3 Aspirating test for syringes of Type 2b

6.3.1 Reagent

A coloured liquid, for example see 6.2.1.

6.3.2 Procedure

Assemble the syringe, cartridge and needle of dimensions 0,4 mm × 35 mm. Depress the plunger 5 mm during 1 s. Release the pressure and then immediately again depress the plunger a further 5 mm for 1 s. Immediately after this second depression, immerse the needle in the coloured liquid (6.3.1) and depress the plunger at a rate of 5 mm/s for 5 mm and release the pressure.

6.3.3 Observation

Observe whether the requirement of 5.1.4.3 is fulfilled.

6.4 Plunger rod tests

6.4.1 Plunger rod movement

When the plunger rod is pulled fully out of an empty syringe held vertically, it shall be capable of travelling freely and smoothly the whole length under the force of gravity in both vertical directions by inverting the syringe.

6.4.2 Plunger rod displacement

With the plunger in the fully forward position in the syringe (without a cartridge) the maximum sideways displacement measured at the front end of the plunger rod tip shall not exceed 2 mm in any direction from the central axis of the syringe.

Dimensions in millimetres

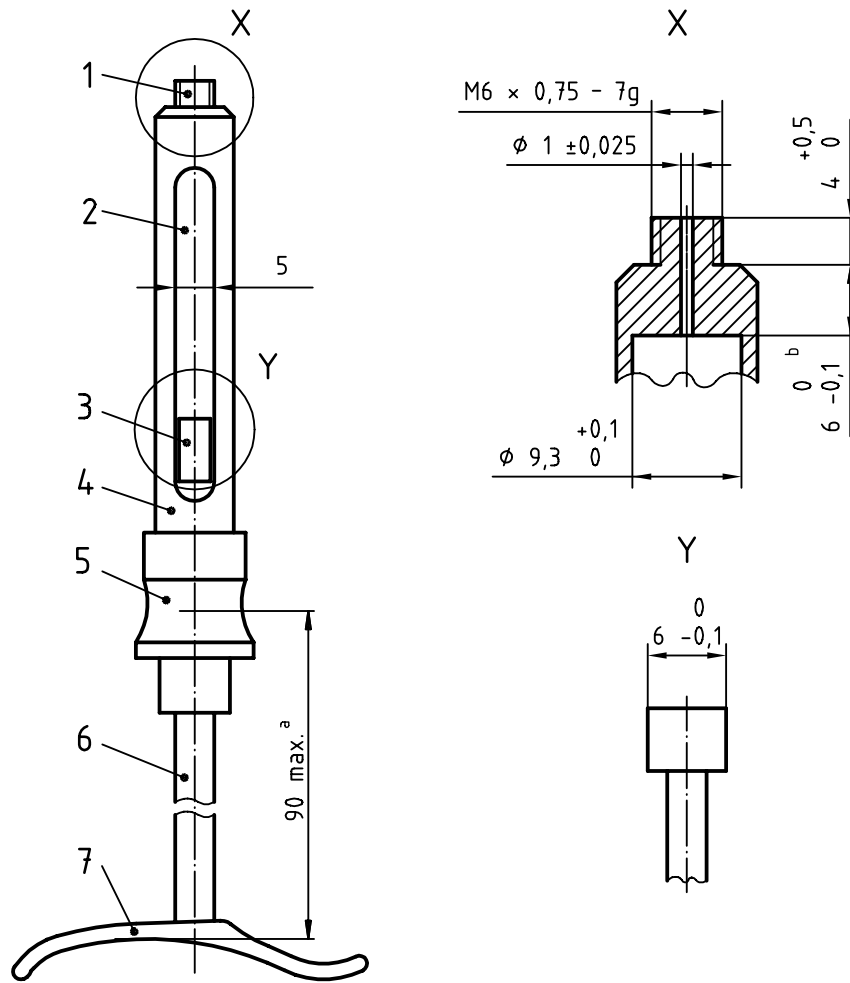

Key

- 1 Threaded needle mounting hub
- 2 Viewing port
- 3 Working end of plunger rod
- 4 Barrel
- 5 Finger grip
- 6 Plunger rod
- 7 Handle

a When a full cartridge is mounted.

b Dimensions includes any aspirating device incorporated at the needle end of the syringe barrel. If no aspirating device is incorporated, dimensions shall be reduced to 4^{+1}_0 .

NOTE The design shown is not necessarily preferable to any other design that may exist.

Figure 1 — Dental cartridge syringe

6.5 Boiling water test for corrosion

Test the dental cartridge syringe in accordance with ISO 13402:1995, clause 4.

Perform the cycle five times.

Visually inspect (see 6.1) for compliance with the requirements of 5.2.1 or 5.2.2 as appropriate.

6.6 Autoclave test for corrosion

Test the dental cartridge syringe in accordance with ISO 13402:1995, clause 3.

Perform the cycle five times.

Visually inspect (see 6.1) for compliance with the requirement of 5.2.1 or 5.2.2 as appropriate.

6.7 Thermal test (metal syringes only)

Test the dental cartridge syringe in accordance with ISO 13402:1995, clause 6.

Perform the cycle five times.

Visually inspect (see 6.1) for compliance with the requirement of 5.2.1.

7 Information supplied by the manufacturer

Each dental cartridge syringe shall be accompanied by at least the following information:

- a) recommended methods for cleaning and sterilization;
- b) method of inserting the cartridge and attaching the needle;
- c) method of assembly, if appropriate;
- d) technique to be used for aspiration, if applicable.

8 Marking

8.1 Marking of unit pack

Each unit pack (see 3.2) shall be marked with the following information:

- a) name or registered trademark of the manufacturer;
- b) words "dental cartridge syringe";
- c) type "aspirating" or "non-aspirating", as appropriate;
- d) if aspirating, type of aspiration;
- e) details of the needle-mounting thread;
- f) size(s) and type of cartridge(s) to use with the syringe;
- g) lot number.

8.2 Marking of syringe

Each syringe shall be indelibly marked with the name or registered trademark of the manufacturer.

Annex A (informative)

Imperial thread size

The introduction to this International Standard mentions the existence of imperial thread sizes for the needle mounting threads. In the interest of patient safety, the imperial thread size used should be $0,216 \begin{smallmatrix} 0 \\ -0,003 \end{smallmatrix}$ in ($5,486 \begin{smallmatrix} 0 \\ -0,08 \end{smallmatrix}$ mm,) 40 TPI (threads per inch) Whitworth form.

ISO 9997:1999(E)

.....

ICS 11.040.20; 11.060.20

Price based on 7 pages

© ISO 1999 – All rights reserved