

INTERNATIONAL STANDARD

**ISO
9994**

Fourth edition
2005-09-01

Lighters — Safety specification

Briquets — Spécifications de sécurité



Reference number
ISO 9994:2005(E)

© ISO 2005

PDF disclaimer

This PDF file may contain embedded typefaces. In accordance with Adobe's licensing policy, this file may be printed or viewed but shall not be edited unless the typefaces which are embedded are licensed to and installed on the computer performing the editing. In downloading this file, parties accept therein the responsibility of not infringing Adobe's licensing policy. The ISO Central Secretariat accepts no liability in this area.

Adobe is a trademark of Adobe Systems Incorporated.

Details of the software products used to create this PDF file can be found in the General Info relative to the file; the PDF-creation parameters were optimized for printing. Every care has been taken to ensure that the file is suitable for use by ISO member bodies. In the unlikely event that a problem relating to it is found, please inform the Central Secretariat at the address given below.

© ISO 2005

All rights reserved. Unless otherwise specified, no part of this publication may be reproduced or utilized in any form or by any means, electronic or mechanical, including photocopying and microfilm, without permission in writing from either ISO at the address below or ISO's member body in the country of the requester.

ISO copyright office
Case postale 56 • CH-1211 Geneva 20
Tel. + 41 22 749 01 11
Fax + 41 22 749 09 47
E-mail copyright@iso.org
Web www.iso.org

Published in Switzerland

Contents

Page

Foreword.....	iv
1 Scope	1
2 Terms and definitions	1
3 Functional requirements	3
4 Structural integrity requirements	7
5 Test methods	9
6 Instructions and warnings	20
7 Product marking	24
Annex A (informative) Manufacturer's acceptance limits for specifications and inset limits for flame characteristics in 3.2.1 and 3.2.2	25
Bibliography	26

Foreword

ISO (the International Organization for Standardization) is a worldwide federation of national standards bodies (ISO member bodies). The work of preparing International Standards is normally carried out through ISO technical committees. Each member body interested in a subject for which a technical committee has been established has the right to be represented on that committee. International organizations, governmental and non-governmental, in liaison with ISO, also take part in the work. ISO collaborates closely with the International Electrotechnical Commission (IEC) on all matters of electrotechnical standardization.

International Standards are drafted in accordance with the rules given in the ISO/IEC Directives, Part 2.

The main task of technical committees is to prepare International Standards. Draft International Standards adopted by the technical committees are circulated to the member bodies for voting. Publication as an International Standard requires approval by at least 75 % of the member bodies casting a vote.

Attention is drawn to the possibility that some of the elements of this document may be the subject of patent rights. ISO shall not be held responsible for identifying any or all such patent rights.

ISO 9994 was prepared by Technical Committee ISO/TC 61, *Plastics*.

This fourth edition cancels and replaces the third edition (ISO 9994:2002). The main change is the inclusion of safety symbols (see Subclause 6.4).

Lighters — Safety specification

1 Scope

This International Standard establishes requirements for lighters to ensure a reasonable degree of safety for normal use or reasonably foreseeable misuse of such lighters by users.

The safety specification given in this International Standard applies to all flame-producing products commonly known as cigarette lighters, cigar lighters and pipe lighters. It does not apply to matches, nor does it apply to other flame-producing products intended solely for igniting materials other than cigarettes, cigars, and pipes.

Lighters, being flame-producing devices, can, as do all flame sources, present a potential hazard to users. The safety specification given in this International Standard cannot eliminate all hazards, but is intended to reduce potential hazards to users.

2 Terms and definitions

For the purposes of this document, the following terms and definitions apply.

2.1

lighter

manually operated flame-producing device, employing a petrochemical derivative as a fuel, normally used for deliberately igniting cigarettes, cigars and pipes, and which may foreseeably be used to ignite materials such as paper, wicks, candles and lanterns

NOTE Lighters are specifically not intended for use as candles or as flashlights, or for other uses requiring an extended burn time.

2.2

fluid lighter

lighter, with an exposed wick, that employs as fuel liquid hydrocarbons such as hexane whose gauge vapour pressure at 24 °C does not exceed 34,5 kPa

2.3

gas lighter

lighter that employs as fuel liquefied hydrocarbons such as *n*-butane, isobutane and propane whose gauge vapour pressure at 24 °C exceeds 104 kPa

2.4

postmixing burner lighter

gas lighter in which fuel is supplied for combustion and air is supplied at the point of combustion

2.5

premixing burner lighter

gas lighter in which fuel and air are mixed before being supplied for combustion

2.6

disposable lighter

lighter marketed with an integral supply of fuel and that is not intended to be refuelled

2.7
refillable lighter
lighter intended to be refuelled either by transferring fuel from an external container or by inserting a new prefilled fuel reservoir

2.8
adjustable lighter
lighter provided with a mechanism for the user to vary the flame height

2.9
non-adjustable lighter
lighter that is not provided with a user-accessible mechanism to adjust the flame height

NOTE The flame height is preset by the manufacturer.

2.10
automatically adjusting pipe lighter
lighter characterized by an automatic increase in flame height when tilted from an upright position, designed specifically for the purpose of lighting pipes

2.11
self-extinguishing lighter
lighter that, once ignited, requires continuous intentional and positive action to maintain a flame and that is subsequently extinguished by the termination of such positive action

2.12
non-self-extinguishing lighter
lighter that, once ignited, does not require intentional or positive action by the user to maintain a flame and requires a subsequent deliberate user action to extinguish the flame

2.13
flame height
linear distance from the tip of the visible flame to the top of the shield or, in the absence of a shield, from the tip of the visible flame to the bottom of the exposed wick or the top of the burner valve orifice

2.14
shield
structure that totally or partially surrounds the burner valve orifice of a gas lighter or the wick of a fluid lighter

2.15
burner valve
component of a gas lighter which controls the release of fuel

2.16
burner valve orifice
tip of the burner valve from which fuel is released

2.17
flaring
variation of flame height from the steady-state flame condition

2.18
sustained self-ignition
propagation of a flame by other than deliberate manual operation, such as by dropping the lighter, so as to cause the ignition element to be activated and the flame to continue to burn

2.19**spitting
sputtering**

flame phenomenon of a gas lighter wherein the escape of non-evaporated liquefied gas produces a shower of burning liquid droplets which separate from the main flame

2.20**flame**

result of combustion of fuel that produces heat and often light which could be visible with the naked eye under normal or subdued lighting conditions

2.21**ignite**

produce a flame with a lighter by activating the self-contained ignition and fuel release systems of that lighter in the intended manner

3 Functional requirements

3.1 Flame generation

In order to minimize the possibility of inadvertent ignition, or self-ignition, lighters shall require a deliberate manual operation to produce a flame. This operation shall conform to at least one of the following requirements:

- a) positive action on the part of the user shall be required to generate and maintain a flame;
- b) two or more independent actions by the user shall be required to generate a flame;
- c) an actuating force equal to, or greater than, 15 N shall be required to generate a flame (see Figure 1 or Figure 2).

3.2 Flame heights

NOTE Maximum flame heights specified in this International Standard, for both postmixing burner lighters and premixing burner lighters, will be reconsidered periodically with a view to gradual reduction in line with technological progress.

3.2.1 Non-adjustable lighters

3.2.1.1 Non-adjustable fluid lighters shall not be capable of producing a flame height greater than 120 mm when tested in accordance with 5.2.

3.2.1.2 Non-adjustable, postmixing and premixing burner lighters shall not be capable of producing a flame height greater than 50 mm when tested in accordance with 5.2.

3.2.2 Adjustable lighters

3.2.2.1 For adjustable lighters as defined in 2.8, the maximum flame height that a user will obtain under different conditions of use shall comply with the following requirements when tested in accordance with 5.2.

3.2.2.2 Adjustable postmixing burner lighters shall have the flame height adjusted by the manufacturer in such a manner that the lighter, when first ignited by the user — without changing the adjustment — will not produce a flame height greater than 100 mm.

3.2.2.3 Adjustable postmixing burner lighters shall not be capable of producing a flame height greater than 120 mm when deliberately adjusted by the user to the manufacturer's design limit for maximum flame height.

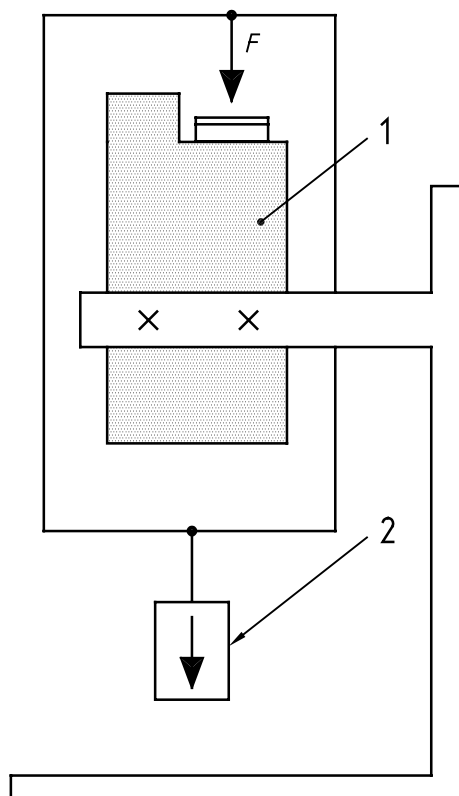

Key

- 1 lighter
- 2 mass
- F flame-generation actuating force

Figure 1 — Application of flame-generation actuating force as specified in 3.1 c) — Push-button actuator

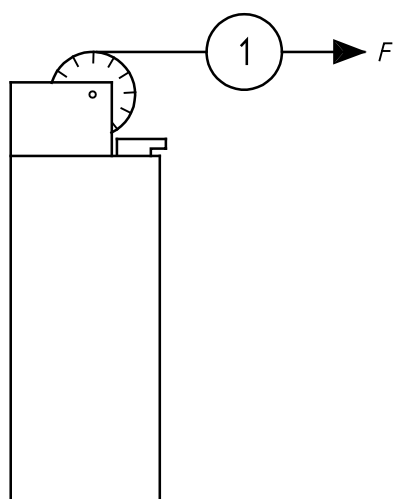

Key

- 1 force gauge
- F flame-generation actuating force

Figure 2 — Application of flame-generation actuating force as specified in 3.1 c) — Rotary actuator

3.2.2.4 Adjustable premixing burner lighters shall have the flame height adjusted by the manufacturer in such a manner that the lighter, when first ignited by the user — without changing the adjustment — will not produce a flame height greater than 60 mm.

3.2.2.5 Adjustable premixing burner lighters shall not be capable of producing a flame height greater than 75 mm when deliberately adjusted by the user to the manufacturer's design limit for maximum flame height.

3.2.2.6 Adjustable postmixing and premixing burner lighters shall not be capable of producing a flame height greater than 50 mm when set at the lowest possible flame height.

3.2.2.7 Automatically adjusting pipe lighters shall not be capable, in any position, of producing a flame height greater than 100 mm.

3.2.2.8 The maximum attainable flame height for lighters shall be limited by pre-setting or by product design, or both.

NOTE See also Annex A on AQLs and the Bibliography for sampling scheme references.

3.3 Flame-height adjustment

3.3.1 Adjustable lighters as defined in 2.8 shall require a deliberate action on the part of the user either to decrease or to increase the flame height when used in the normal manner. Adjustable lighters shall bear an indication showing the direction of movement of the adjusting mechanism required to produce a higher or lower flame.

3.3.2 On lighters whose adjusting mechanisms conform to 3.3.3 and 3.3.4, the direction of movement shall be permanently imprinted or engraved on the lighter in the vicinity of the adjusting mechanism and readily visible and understandable.

3.3.3 Gas lighters having rotary-movement flame-control actuators approximately at right-angles to the flame shall perform as follows:

- a) when the flame-control actuator is at the top of the lighter and the lighter is held so that the flame is oriented vertically upward, and the user is facing the flame-control actuator, moving the actuator to the left shall produce a decrease in flame height;
- b) when the flame-control actuator is at the bottom of the lighter, and the lighter is held so that the user is facing the actuator, a clockwise movement shall produce a decrease in flame height.

3.3.4 For gas lighters requiring movement of the flame-control actuator approximately parallel to the flame axis, the flame height shall decrease or increase in accordance with the direction of the movement.

3.3.5 If the flame-control actuator protrudes from the body of the lighter, it shall require a minimum actuating force of 1 N applied over the entire range of adjustment in a tangential direction (see Figure 3).

3.4 Resistance to spitting or sputtering and flaring

Gas lighters as defined in 2.3, when set at the maximum flame height, shall exhibit no spitting or sputtering as defined in 2.19, or flaring as defined in 2.17, when tested in accordance with 5.3.

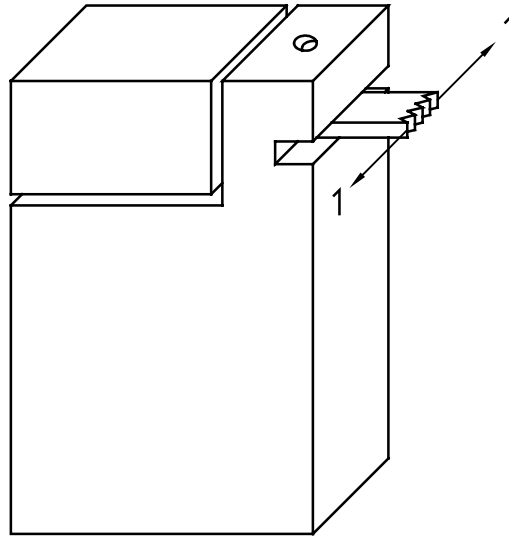

Key

1 direction of flame-control actuating force

Figure 3 — Application of flame-control actuating force as specified in 3.3.5

3.5 Flame extinction

When a lighter is extinguished in the intended manner, for example by closing a cover or by releasing a button or a lever, it shall meet the following requirements with respect to extinction time.

- a) Non-adjustable fluid and postmixing burner lighters, at their permanently set flame heights, when tested in accordance with 5.4, shall have any exposed flame completely extinguished within 2 s after a 10 s burn.
- b) Adjustable postmixing burner lighters, when tested in accordance with 5.4, shall have any flame completely extinguished within 2 s
 - 1) after a 10 s burn when set at a flame height of 50 mm, or the maximum flame height the adjustment allows if lower than 50 mm;
 - 2) after a 5 s burn when set at maximum flame height.
- c) In the case of postmixing burner lighters that have shields, an additional 2 s afterburn (i.e. continuous burning) is acceptable if the flame, during this additional 2 s period, does not extend above the shield.
- d) Non-adjustable premixing burner lighters, at their permanently set flame heights, when tested in accordance with 5.4, shall have any flame completely extinguished in no more than 5 s.
- e) Adjustable premixing burner lighters, when tested in accordance with 5.4, shall have any flame completely extinguished in no more than 5 s
 - 1) after a 10 s burn when set at a flame height of 50 mm, or the maximum flame height the adjustment allows if lower than 50 mm;
 - 2) after a 5 s burn when set at maximum flame height.

NOTE In the case of premixing burner gas lighters, the total afterburn time in this International Standard will be reconsidered periodically with a view to gradual reduction in line with technological progress.

3.6 Volumetric displacement

For gas lighters shipped with fuel, the liquid portion of the fuel shall not exceed 85 % of the volumetric capacity of the fuel reservoir when tested in accordance with 5.7.

4 Structural integrity requirements

4.1 External finish

Lighters shall have no external sharp edges that could cause accidental cuts or abrasions to the user when handled or used in the intended manner.

4.2 Compatibility with fuel

4.2.1 Components of fluid lighters as defined in 2.2 that come into contact with the fuel recommended by the manufacturer shall not, after extended contact with that fuel, deteriorate so as to cause the lighter to fail any of the criteria contained in this specification, when tested in accordance with 5.5.

4.2.2 Components of gas lighters as defined in 2.3 that come into contact with the fuel recommended by the manufacturer shall not deteriorate after exposure to the fuel, so as to cause the lighter to fail any of the criteria contained in this specification or allow gas escape exceeding 15 mg/min, when tested in accordance with 5.5.

4.2.3 Lighters that meet the requirements of 4.2.1 and 4.2.2 and that are able to be ignited in the intended manner shall be capable of meeting all applicable requirements of Clause 3. Lighters that are not able to be ignited in the intended manner do not constitute a failure.

4.3 Resistance to fuel loss

4.3.1 Refillable fluid lighters having a sealed fuel reservoir shall have a sealing closure which shall prevent loss or leakage of fuel from both the sealed reservoir and the sealing closure when such sealing closure is installed in the lighter by the user in the intended manner, when tested in accordance with 5.6.

4.3.2 Refillable gas lighters shall have a pressurized fuel reservoir whose refilling valve shall be secure enough to prevent an escape of gas exceeding 15 mg/min, when tested in accordance with 5.6.

4.4 Resistance to dropping

4.4.1 Without impairing their subsequent safe operation, lighters shall be capable of withstanding three separate $(1,5 \pm 0,1)$ m drops conducted in accordance with 5.8:

a) without fuel reservoir rupture/fragmentation

and

b) without sustained self-ignition as defined in 2.18.

In addition, for gas lighters, gas escape shall not exceed 15 mg/min.

4.4.2 Lighters that meet these requirements and that are able to be ignited in the intended manner shall subsequently meet all the requirements of Clause 3. Lighters that are not able to be ignited in the intended manner do not constitute a failure.

In the event of a shield becoming detached during the drop test, it can be re-attached, if this is practicable, and the test continued.

4.5 Resistance to elevated temperature

4.5.1 Gas lighters, and fluid lighters with a sealed compartment filled with non-absorbed fuel, shall be capable of withstanding a temperature of 65 °C for 4 h when tested in accordance with 5.9.

4.5.2 Lighters that meet this requirement, and that are able to be ignited in the intended manner, shall be capable after stabilization at a temperature of (23 ± 2) °C of meeting all the applicable requirements of Clause 3. Lighters that are not able to be ignited in the intended manner do not constitute a failure.

4.6 Resistance to internal pressure

Gas lighters shall be capable of withstanding an internal pressure of twice the vapour pressure at 55 °C of the fuel recommended by the manufacturer, when tested in accordance with 5.10.

4.7 Burning behaviour

4.7.1 The following types of lighter shall be capable of withstanding a burning time of 5 s when held in a position such that the top of the wick, or burner valve orifice, is at an angle 45° below the horizontal (see Figure 4), without evidence of any burning or distortion of components so as to cause a hazardous condition:

a) adjustable gas lighters, with the flame height set at maximum.

4.7.2 The following types of lighter shall be capable of withstanding a burning time of 10 s when held in a position such that the top of the wick, or burner valve orifice, is at an angle of 45° below the horizontal (see Figure 4), without evidence of any burning or distortion of components so as to cause a hazardous condition:

a) fluid lighters;

b) non-adjustable gas lighters at their permanently set flame heights;

c) adjustable gas lighters, with the flame height set at 50 mm, or the maximum flame height the adjustment allows if lower than 50 mm.

4.8 Resistance to cyclic burning

The following types of lighter shall be capable of withstanding a burning time of 20 s — repeated 10 times — when tested in accordance with 5.11:

a) fluid lighters;

b) non-adjustable gas lighters at their permanently set flame heights;

c) adjustable gas lighters, with the flame height set at 50 mm, or the maximum flame height the adjustment allows if lower than 50 mm.

Lighters that meet this requirement, and that are still able to be ignited in the intended manner, shall subsequently be capable of meeting all applicable requirements of Clause 3. Lighters that are not able to be ignited in the intended manner do not constitute a failure.

4.9 Resistance to continuous burning

The following types of lighter shall be capable of withstanding a continuous burning time of 2 min with the flame in a vertically upward position without causing a hazardous condition, when tested in accordance with 5.12:

a) fluid lighters;

b) non-adjustable gas lighters at their permanently set flame heights;

c) adjustable gas lighters, with the flame height set at 50 mm, or the maximum flame height the adjustment allows if lower than 50 mm.

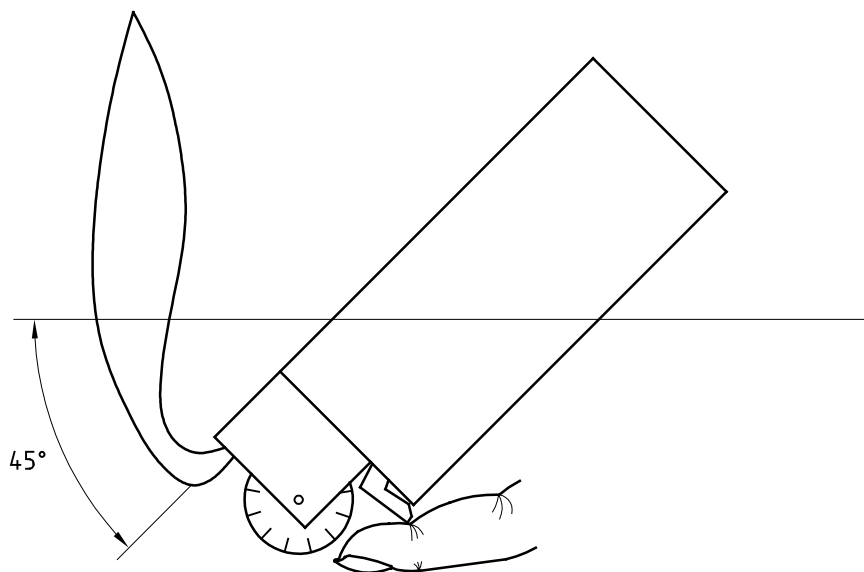

Figure 4 — Position of the lighters for the burning tests described in 4.7.1 and 4.7.2

5 Test methods

SAFETY STATEMENT — Persons using this document should be familiar with normal laboratory practice, if applicable. This document does not purport to address all of the safety concerns, if any, associated with its use. It is the responsibility of the user to establish appropriate safety and health practices and to ensure compliance with any regulatory requirements.

5.1 Test specimens

Unless otherwise noted in the test methods described hereafter, test specimens shall consist of new, complete, normally fuelled lighters and shall be initially free of mechanical damage.

5.2 Flame height measurement

5.2.1 Apparatus

5.2.1.1 Vertically supported non-flammable board, marked horizontally in 5 mm increments. The board shall be fitted with a stand-off at the base point, to position the lighter at least 25 mm from the board.

5.2.1.2 Draught-free chamber, constructed from non-flammable materials.

5.2.2 Procedure

5.2.2.1 Tests shall be conducted inside the draught-free chamber. In the case of premixing burner lighters, it is recommended this test be conducted under subdued lighting conditions.

5.2.2.2 Stabilize all test specimens at $(23 \pm 2)^\circ\text{C}$ for at least 10 h prior to each flame height measurement.

5.2.2.3 Place a specimen against the stand-off so that the flame will be directed vertically upward.

5.2.2.4 Ignite the specimen lighter and determine the flame height, as defined in 2.13, to the nearest 5 mm by means of the marks on the board behind the lighter, during a 5 s burn.

5.3 Spitting, sputtering and flaring tests

5.3.1 General

Fluid lighters as defined in 2.2 shall be excluded from this test.

5.3.2 Procedure

5.3.2.1 Stabilize all test specimens at (23 ± 2) °C for at least 10 h prior to each spitting, sputtering and flaring test.

5.3.2.2 If the lighters are adjustable, as defined in 2.8, adjust the flame to its maximum height.

5.3.2.3 Ignite a lighter and observe for spitting or sputtering, as defined in 2.19, during a 5 s burn in any hand-held attitude.

Failure: Any evidence of spitting or sputtering constitutes a failure.

5.3.2.4 If the lighter does not fail, restabilize for a minimum of 5 min at (23 ± 2) °C before continuing with procedure 5.3.2.7.

5.3.2.5 If different gas lighters are used to conduct the test described in 5.3.2.7, stabilize each lighter in accordance with 5.3.2.1.

5.3.2.6 Automatically adjusting pipe lighters as defined in 2.10 shall be excluded from procedures 5.3.2.7 to 5.3.2.12.

5.3.2.7 Ignite the lighter with the flame directed vertically upward. Observe the flame height and invert the lighter to an angle 45° below the horizontal (see Figure 5), again observing the average or steady-state flame height during the procedure. Extinguish the lighter and return it to the vertical position.

Failure: An increase, at any time, in flame height of more than 50 mm above the steady-state flame height during a total elapsed time of 5 s, or a maximum flame height exceeding the maximum values stated in 3.2, constitutes a failure.

5.3.2.8 If the lighter does not fail, restabilize for a minimum of 5 min at (23 ± 2) °C before continuing with procedures 5.3.2.10, 5.3.2.11 and 5.3.2.12.

5.3.2.9 If different gas lighters are used to conduct tests as described in 5.3.2.10, 5.3.2.11 and 5.3.2.12, stabilize each lighter in accordance with 5.3.2.1.

5.3.2.10 Invert the lighter for a period of 10 s.

5.3.2.11 Reorient the lighter so that the flame will be directed vertically upward and ignite it.

5.3.2.12 Observe the flame height during a 5 s burn.

Failure: Any variation of flame exceeding 50 mm or exceeding the maximum values stated in 3.2 constitutes a failure.

5.4 Flame extinction test

5.4.1 Apparatus

As described in 5.2.1.

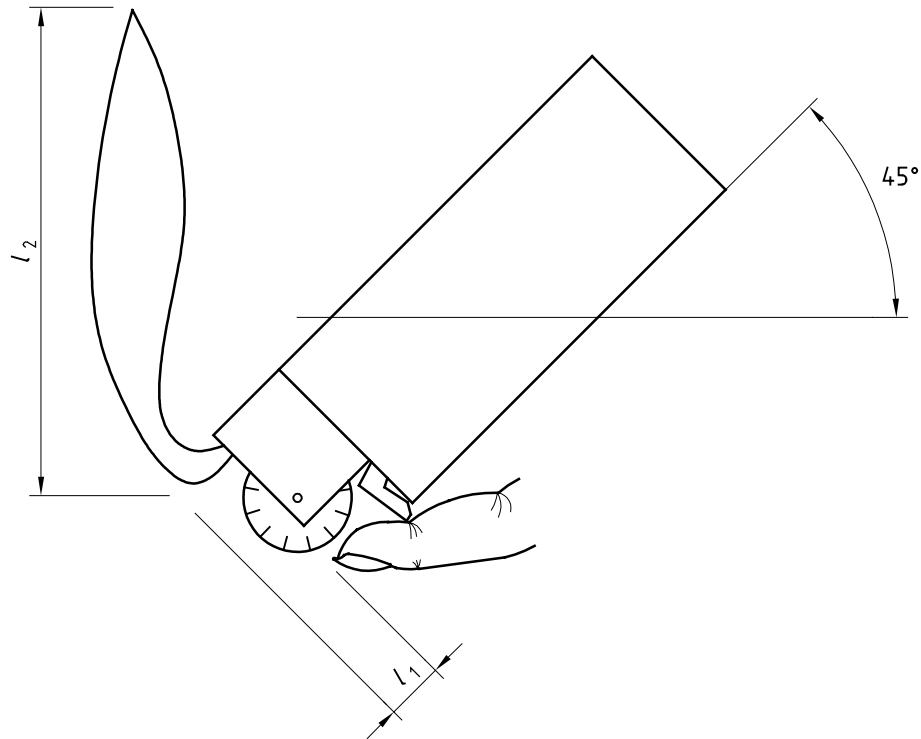

Flame height = $l_1 + l_2$

Figure 5 — Flame height measurement for the flaring test described in 5.3.2.7

5.4.2 Procedure

5.4.2.1 Stabilize all test specimens at $(23 \pm 2)^\circ\text{C}$ for at least 10 h. It is recommended that the test be conducted under subdued lighting conditions.

5.4.2.2 Place a lighter against the flame height measurement apparatus so that the flame will be directed vertically upward.

5.4.2.3 Ignite and adjust to the flame height specified in 3.5 a) or 3.5 b) or 3.5 d) or 3.5 e), as appropriate.

5.4.2.4 Extinguish and allow to cool for 1 min.

5.4.2.5 Ignite for the period(s) of time specified in 3.5 a) or 3.5 b) or 3.5 d) or 3.5 e), and extinguish in the normal manner.

5.4.2.6 Measure and record the time of any burning occurring after the extinguishing action.

Failure: Afterburning (i.e. continuous burning) in excess of the period of time specified in 3.5 constitutes a failure.

5.5 Fuel compatibility test

5.5.1 General

The purpose of the test is to determine whether lighter components coming into contact with the fuel recommended by the manufacturer deteriorate in any fashion or result in fuel leakage as specified in this test.

Lighters used in testing for the requirements of 3.1 to 3.5, inclusive, may be used for this compatibility test.

5.5.2 Apparatus

5.5.2.1 For fluid lighters:

5.5.2.1.1 **Container**, capable of being hermetically sealed.

5.5.2.1.2 **Enclosure**, ventilated to prevent the accumulation of gas or vapour, capable of maintaining a temperature of (40 ± 2) °C.

5.5.2.2 For gas lighters:

5.5.2.2.1 **Enclosure**, ventilated to prevent the accumulation of gas or vapour, capable of maintaining a temperature of (40 ± 2) °C.

5.5.2.2.2 **Device for measuring temperature**, accurate to ± 1 °C within the range 35 °C to 45 °C.

5.5.2.2.3 **Balance having a sensitivity of 0,1 mg.**

5.5.3 Procedure

5.5.3.1 For fluid lighters:

5.5.3.1.1 Fuel the specimens according to the method, and with the fuel, recommended by the manufacturer.

5.5.3.1.2 Ignite the specimens in the intended manner to assure the lighters are operable.

5.5.3.1.3 Place the extinguished specimens in the container, with their covers and closures in the open position.

5.5.3.1.4 Fill the container with the fuel recommended by the manufacturer so that the specimens are submerged in the fuel. Seal the container.

5.5.3.1.5 Stabilize the enclosure at (40 ± 2) °C.

5.5.3.1.6 Place the container in the enclosure for 28 days.

5.5.3.1.7 After 28 days, remove the container from the enclosure and the specimens from the container.

5.5.3.1.8 Let the specimens dry thoroughly.

5.5.3.1.9 Refuel the specimens according to the method, and with the fuel, recommended by the manufacturer.

5.5.3.1.10 Stabilize the specimens at a temperature of (23 ± 2) °C for at least 10 h.

5.5.3.1.11 Check visually for liquid fuel leakage with lighters in all orientations.

Failure: Any leakage constitutes a failure.

5.5.3.1.12 Lighters that are able to be ignited in the intended manner shall subsequently meet all the requirements of Clause 3.

5.5.3.1.13 Lighters that are not able to be ignited do not constitute a failure.

5.5.3.1.14 The reproducibility of this test is dependent on the life history of the specimen(s) and, therefore, it shall be performed with newly manufactured lighters.

5.5.3.2 For gas lighters:

5.5.3.2.1 Stabilize the enclosure at (40 ± 2) °C.

5.5.3.2.2 Ignite each specimen briefly to ensure it is not empty of fuel, and place the extinguished specimens in the enclosure for 28 days.

5.5.3.2.3 After 28 days, remove the specimens from the enclosure.

5.5.3.2.4 Stabilize the specimens at a temperature of (23 ± 2) °C for at least 10 h.

5.5.3.2.5 Determine, by weighing, whether the specimens allow a rate of gas escape exceeding 15 mg/min.

Failure: Gas escape exceeding 15 mg/min constitutes a failure. A lighter empty of liquid fuel also constitutes a failure.

If the lighter fuel reservoir is totally or partially transparent, observe visually the presence of liquid fuel inside the reservoir. In the absence of liquid fuel, the lighter is empty.

5.5.3.2.6 All lighters that are able to be ignited in the intended manner shall subsequently meet all requirements of Clause 3. Lighters that are not able to be ignited in the intended manner do not constitute a failure.

If the lighter fuel reservoir is not transparent, proceed to 5.5.3.2.7.

5.5.3.2.7 Non-transparent lighters that are not able to be ignited in the intended manner shall be tested as follows to determine if they are empty of liquid fuel:

- a) weigh the lighter with a balance having a sensitivity of 0,1 mg;
- b) open the reservoir (pushing the sealing ball or opening the burner valve for a non-refillable lighter, or opening the refilling valve for a refillable lighter);
- c) reweigh the lighter with all its components.

If the mass is unchanged within ± 10 mg, the lighter was an empty lighter.

5.5.3.2.8 All lighters that are able to be ignited in the intended manner shall subsequently meet all requirements of Clause 3. Lighters that are not able to be ignited in the intended manner do not constitute a failure.

5.5.3.2.9 The reproducibility of this test is dependent on the life history of the specimen(s) and, therefore, it shall be performed with newly manufactured lighters.

5.6 Refilling test**5.6.1 General**

The purpose of the test is to ensure that no dangerous fuel leakage occurs from the refilling closure of lighters.

5.6.2 Apparatus

5.6.2.1 For refillable gas lighters: **balance**, sufficiently sensitive to measure gas escape over the elapsed period of time.

5.6.3 Procedure

5.6.3.1 For fluid lighters with a sealed fuel reservoir:

5.6.3.1.1 Remove the sealing closure from the refill orifice from lighters with a sealed fuel reservoir.

5.6.3.1.2 Fill the fuel reservoir by the method, and with the fuel, recommended by the manufacturer.

5.6.3.1.3 Replace the sealing closure of the refill orifice, wipe the lighter and dry.

5.6.3.1.4 Observe for fuel leakage from either the vicinity of the sealing closure or from the fuel reservoir itself.

Failure: Any evidence of fuel leakage constitutes failure.

5.6.3.2 For refillable gas lighters:

5.6.3.2.1 Empty the lighter fuel reservoir, then refill it according to the method, and with the fuel, recommended by the manufacturer.

5.6.3.2.2 Determine, by weighing, whether the rate of gas escape exceeds 15 mg/min.

Failure: Gas escape exceeding 15 mg/min constitutes failure.

5.7 Volumetric fuel-displacement test

5.7.1 General

The purpose of the test is to determine the amount of volumetric displacement of the liquid portion of the fuel relative to the volumetric capacity of the fuel reservoir. Fluid lighters as defined in 2.2 shall be excluded from this test.

5.7.2 Test specimens

The test specimens shall consist of lighters as prepared for shipment.

5.7.3 Apparatus

5.7.3.1 **Balance**, having a sensitivity of 0,1 mg.

5.7.4 Procedure

5.7.4.1 Stabilize all specimen lighters at (23 ± 2) °C for at least 10 h.

5.7.4.2 Determine the mass of the fuel by weighing a full unused specimen lighter, draining the fuel, and reweighing the empty lighter after 30 min.

5.7.4.3 Calculate the volume V_1 of the liquid portion of the fuel using the density of the fuel at (23 ± 2) °C:

$$V_1 = \frac{\text{Mass of fuel (grams)}}{\text{Density of fuel at } (23 \pm 2) \text{ °C (g/cm}^3\text{)}}$$

If the fuel type and formulation are not known, use 0,54 g/cm³ for the density.

5.7.4.4 Drill a hole no larger than 6 mm in the fuel reservoir and then weigh the lighter.

5.7.4.5 Fill the fuel reservoir with distilled water at a temperature of (23 ± 2) °C using a syringe or other suitable device and ensuring that there are no air bubbles within the reservoir.

Depending upon the design of the lighter and its fuel reservoir (size, shape and wall thickness), a vent hole may need to be drilled into the fuel reservoir in such a place as to facilitate the removal of trapped air during the filling. If a vent hole is used, then weigh the lighter after drilling both the fill and vent holes.

5.7.4.6 Weigh the water-filled lighter.

5.7.4.7 Determine the mass of water by subtracting the mass of the empty lighter (see 5.7.4.4) from the mass of the water-filled lighter (see 5.7.4.6), or by measuring the amount of water required to fill the fuel reservoir of the specimen lighter, or by any other convenient means.

5.7.4.8 Calculate the volume of the lighter reservoir V_0 as follows:

$$V_0 = \frac{\text{Mass of water (grams)}}{\text{Density of water at } (23 \pm 2) \text{ °C (g/cm}^3\text{)}}$$

Failure: A ratio V_1/V_0 greater than 0,85 constitutes a failure.

5.8 Drop test

5.8.1 General

The purpose of the test is to determine the ability of the lighter to withstand safely a drop that may occur during its use.

Lighters used in testing for the requirements of 3.1 to 3.5, inclusive, may be used for this test.

5.8.2 Apparatus

5.8.2.1 Concrete surface.

5.8.2.2 Height-measuring device, marked to a height of $(1,5 \pm 0,1)$ m.

5.8.2.3 Balance, having a sensitivity of 0,1 mg if gas escape is measured over an elapsed time of 1 min, or 1 mg if gas is measured over an elapsed time of 10 min.

5.8.3 Procedure

5.8.3.1 For each type of lighter:

Carry out the drop test on two different specimens.

Specimen 1: The lighter shall be stabilized at (23 ± 2) °C for at least 10 h.

For an adjustable lighter, the flame height shall be set to its maximum height.

Specimen 2: The lighter shall be maintained at a temperature of (-10 ± 2) °C for 24 h and then stabilized at a temperature of (23 ± 2) °C for at least 10 h.

For an adjustable lighter, the flame height shall be set at 50 mm maximum.

5.8.3.2 For fluid lighters:

5.8.3.2.1 Allow each specimen to fall freely from a height of $(1,5 \pm 0,1)$ m onto the concrete surface, from each of the following initial orientations:

- a) base down;
- b) base up;
- c) horizontal.

Lighters fitted with a cover shall have their cover closed during the drop test.

5.8.3.2.2 Observe the specimen during each drop for fuel reservoir rupture, or for sustained self-ignition.

Failure: Either rupture/fragmentation or sustained self-ignition constitutes a failure.

5.8.3.3 For gas lighters:

5.8.3.3.1 Allow each specimen to fall freely from a height of $(1,5 \pm 0,1)$ m onto the concrete surface, from each of the following initial orientations:

- a) base down;
- b) base up;
- c) horizontal.

Lighters fitted with a cover shall have their cover closed during the drop test.

5.8.3.3.2 Observe the specimen during each drop for fuel reservoir fragmentation, or for sustained self-ignition.

Failure: Either rupture/fragmentation or sustained self-ignition constitutes a failure.

5.8.3.3.3 Within 5 min after the three drop tests, determine by weighing whether the rate of gas loss exceeds 15 mg/min.

Failure: Gas loss exceeding this rate constitutes a failure.

5.8.3.4 All lighters that do not fail the tests under 5.8.3.2 and 5.8.3.3, and that are able to be ignited in the intended manner, shall subsequently meet all requirements of Clause 3.

5.8.3.5 Lighters that are not able to be ignited in the intended manner do not constitute a failure.

5.9 Elevated-temperature test

5.9.1 General

The purpose of the test is to determine the ability of a fuel reservoir, including closures, to withstand elevated temperatures without fuel reservoir rupture/fragmentation and without impairing subsequent operation of the lighter in a safe manner.

Lighters used in testing for the requirements of 3.1 to 3.5, inclusive, may be used for this temperature test.

5.9.2 Apparatus

5.9.2.1 Enclosure, vented to prevent accumulation of gas, capable of maintaining a temperature of (65 ± 2) °C.

5.9.2.2 Device for measuring the temperature to within ± 2 °C.

5.9.2.3 Balance, having a sensitivity of 0,1 mg.

5.9.3 Procedure

5.9.3.1 Stabilize the enclosure temperature at (65 ± 2) °C.

5.9.3.2 Ignite each specimen briefly to ensure it is not empty of fuel, and place the extinguished specimens in the enclosure for at least 4 h.

5.9.3.3 After 4 h, remove the specimen and stabilize it at a temperature of (23 ± 2) °C for at least 10 h.

5.9.3.4 For fluid lighters, after temperature stabilization, if the lighter is empty of fluid, refuel it according to the method, and with the fuel, recommended by the manufacturer.

Failure: Rupture/fragmentation of a fuel reservoir, including closures, constitutes a failure.

5.9.3.5 Fluid lighters that are able to be ignited in the intended manner shall subsequently meet all the requirements of Clause 3. Fluid lighters that cannot be ignited in the intended manner do not constitute a failure.

5.9.3.6 For gas lighters, after temperature stabilization, determine, by weighing, whether the rate of gas loss exceeds 15 mg/min.

Failure: Gas loss exceeding 15 mg/min constitutes a failure. A lighter empty of liquid fuel also constitutes a failure.

If the lighter fuel reservoir is totally or partially transparent, observe visually the presence of liquid fuel inside the reservoir. In the absence of liquid fuel, the lighter is empty.

5.9.3.7 Gas lighters that are able to be ignited in the intended manner shall subsequently meet the requirements of Clause 3. Gas lighters that are not able to be ignited in the intended manner do not constitute a failure.

If the lighter fuel reservoir is not transparent, proceed to 5.9.3.8.

5.9.3.8 Non-transparent lighters that are not able to be ignited in the intended manner shall be tested as follows to determine if they are empty of liquid fuel:

- a) weigh the lighter with a balance having a sensitivity of 0,1 mg;
- b) open the reservoir (pushing the sealing ball or opening the burner valve for a non-refillable lighter, or opening the refilling valve for a refillable lighter);
- c) weigh the lighter again with all its components.

If the mass is unchanged within ± 10 mg, the lighter was an empty lighter.

5.9.3.9 Gas lighters that are able to be ignited in the intended manner shall subsequently meet the requirements of Clause 3. Gas lighters that are not able to be ignited in the intended manner do not constitute a failure.

5.10 Internal-pressure test

5.10.1 General

The purpose of the test is to determine the ability of fuel reservoirs, including their closures, to withstand abnormally high internal pressure safely.

Fluid lighters as defined in 2.2 shall be excluded from this test.

5.10.2 Test specimens

Specimens shall consist of new lighters which have been drained of fuel and are free of mechanical damage.

Lighters used in testing for the requirements of 3.1 to 3.5, inclusive, may be used for this pressure test.

5.10.3 Apparatus

5.10.3.1 Any device capable of producing an internal pressure of 2 MPa.

5.10.4 Procedure

5.10.4.1 Conduct the test at an ambient temperature of (23 ± 2) °C.

5.10.4.2 Subject the specimen to an internal pressure of twice the vapour pressure occurring at 55 °C of the fuel recommended by the manufacturer, with a pressure rise not exceeding a rate of 69 kPa/s.

5.10.4.3 Observe whether there is any rapid drop of pressure during the course of the test.

Failure: Any evidence of a rapid drop of pressure constitutes a failure.

5.11 Cyclic-burning-time test

5.11.1 General

The purpose of the test is to determine the ability of lighters to withstand a burning time of 20 s, repeated 10 times with a rest period of 5 min between burnings, without impairing their subsequent safe operation.

Lighters used in testing for the requirements of 3.1 to 3.5, inclusive, may be used for this burning test.

5.11.2 Procedure

5.11.2.1 For fluid lighters and non-adjustable gas lighters:

5.11.2.1.1 Test with flames at their permanently set heights.

5.11.2.1.2 Stabilize specimen lighters at a temperature of (23 ± 2) °C for at least 10 h.

5.11.2.1.3 Ignite a specimen lighter so that the flame will be directed vertically upward, and allow to burn for 20 s.

5.11.2.1.4 Allow the extinguished lighter to stand for 5 min.

5.11.2.1.5 Repeat operations 5.11.2.1.3 and 5.11.2.1.4 nine more times, making a total of 10 cycles.

5.11.2.1.6 Stabilize the specimen lighters at a temperature of (23 ± 2) °C for at least 10 h.

5.11.2.1.7 Lighters that are able to be ignited in the intended manner shall subsequently meet all requirements of Clause 3.

5.11.2.1.8 Lighters that are not able to be ignited in the intended manner do not constitute a failure.

5.11.2.2 For adjustable gas lighters:

5.11.2.2.1 Test with flames at 50 mm, or the maximum flame height the adjustment allows if lower than 50 mm.

5.11.2.2.2 Stabilize specimen lighters at a temperature of (23 ± 2) °C for at least 10 h.

5.11.2.2.3 Ignite a specimen lighter so that the flame will be directed vertically upward, and allow to burn for 20 s.

5.11.2.2.4 Allow the extinguished lighter to stand for 5 min.

5.11.2.2.5 Repeat operations 5.11.2.2.3 and 5.11.2.2.4 nine more times, making a total of 10 cycles.

5.11.2.2.6 Stabilize the specimen lighters at a temperature of (23 ± 2) °C for at least 10 h.

5.11.2.2.7 Lighters that are able to be ignited in the intended manner shall subsequently meet all requirements of Clause 3.

5.11.2.2.8 Lighters that are not able to be ignited in the intended manner do not constitute a failure.

5.12 Continuous-burning-time test

5.12.1 General

The purpose of the test is to determine the ability of lighters to withstand continuous burning for 2 min without causing a hazardous condition.

Lighters used in testing for the requirements of 3.1 to 3.5, inclusive, may be used for this burning test.

5.12.2 Apparatus

5.12.2.1 Draught-free chamber, constructed from non-flammable materials.

5.12.3 Procedure

5.12.3.1 For fluid lighters and non-adjustable gas lighters:

- a) Test with flames at their permanently set heights.
- b) Stabilize specimen lighters at a temperature of (23 ± 2) °C for at least 10 h.
- c) Ignite a specimen lighter so that the flame will be directed vertically upward, and allow to burn for 2 min.
- d) Observe the specimen during the burn.

Failure: Appearance, at any time during the test of

- continued burning of any component part,
 - expulsion of valve components,
 - fuel reservoir rupture/fragmentation, either with or without a flame,
- constitutes a failure.

Lighters used for the continuous-burning-time test shall not be used again for any other tests.

The fact that a lighter fails to complete this test does not constitute a failure of the test.

5.12.3.2 For adjustable gas lighters:

- a) Set the flame height at 50 mm, or the maximum flame height the adjustment allows if lower than 50 mm.
- b) Stabilize specimens at a temperature of (23 ± 2) °C for at least 10 h.
- c) Ignite a specimen lighter so that the flame will be directed vertically upward, and allow to burn for 2 min.
- d) Observe the specimen during the burn.

Failure: Appearance, at any time during the test of

- continued burning of any component part,
 - expulsion of valve components,
 - fuel reservoir rupture/fragmentation, either with or without a flame,
- constitutes a failure.

Lighters used for the continuous-burning-time test shall not be used again for any other tests.

The fact that a lighter fails to complete this test does not constitute a failure of the test.

6 Instructions and warnings

6.1 General

All lighters shall be accompanied by appropriate safety information (instructions or warnings, or both), either in text form or in the form of safety symbols that would replace all existing textual instructions and warnings, or both, communicating to the user the proper method of usage.

6.2 Location

The safety information shall be either on the lighter itself, or in a separate brochure or pamphlet packed with the lighter, or on the consumer product packaging provided for the point of sale. This information shall emphasize the warnings that are most appropriate to the type of lighter. The safety information shall be conspicuously placed, with a contrasting background, colour, type size or style distinct from other information.

6.3 Content

6.3.1 For all lighters, the safety information shall be accompanied by the specific word **“WARNING”** in close proximity to the safety information and shall contain the following statements:

- **“KEEP AWAY FROM CHILDREN”** or **“KEEP OUT OF REACH OF CHILDREN”**.

(The statement used shall be emphasized and distinctive.)

- **“Ignite lighter away from face and clothing”**.

The safety information shall include the substance of the following, as appropriate to the type of lighter:

- a) "Contains flammable gas under pressure".
- b) "Contains flammable fluid".
- c) "When filled, will contain flammable fluid".
- d) "Never expose to heat above 50 °C or to prolonged sunlight".
- e) "Never puncture or put in fire".

6.3.2 Use the following as appropriate to the type of lighter:

- a) "Be sure flame is out after use".
(This statement shall accompany all self-extinguishing lighters.)
- b) "This lighter does not self-extinguish — Close the cover to put out".
(This statement shall accompany all non-self-extinguishing lighters.)
- c) "Extreme heat is present above the visible flame. Extra care should be taken to prevent burn injury or fire".
(This statement shall accompany all premixing burner lighters.)
- d) "Do not keep lit for more than 10 s".
(This statement shall accompany all premixing burner lighters.)

6.4 Safety symbols

If safety signs are used, they shall be as follows:

a) "WARNING" symbol

- Background: white
- Triangular band: black or red
- Graphical symbol: same colour as triangular band (black or red)

The symbol shall have the same proportions as those indicated in Figure 6.

The size shall be at least 10 mm



or



Figure 6

a) **“KEEP AWAY FROM CHILDREN” symbol**

Background:	white
Circular band and diagonal bar:	red
Graphical symbol:	black

The symbol shall have the same proportions as those indicated in Figure 7.

The size shall be at least 10 mm.



Figure 7

b) **“CAUTION, RISK OF FIRE” symbol**

Background:	white
Triangular band:	black or red
Graphical symbol:	same colour as triangular band (black or red)

The symbol shall have the same proportions as those indicated in Figure 8.

The size shall be at least 10 mm

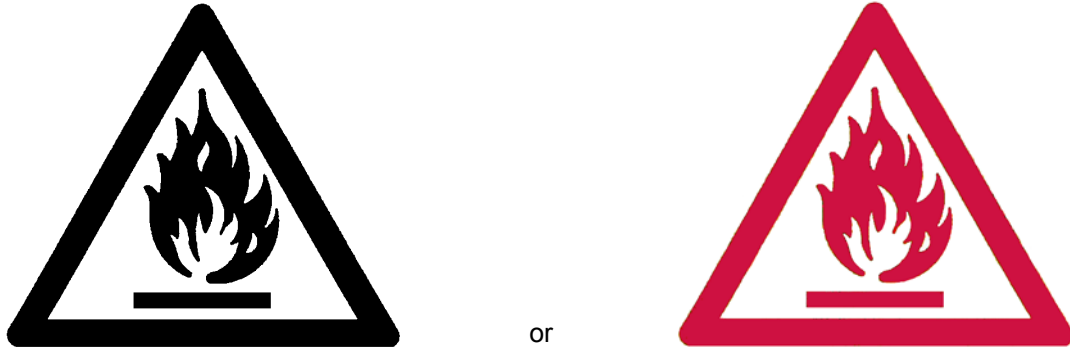

or

Figure 8

c) “NEVER EXPOSE TO HEAT ABOVE 50 °C OR TO PROLONGED SUNLIGHT” symbol

Background: white

Circular band and diagonal bar: red

Graphical symbol: black

The symbol shall have the same proportions as those indicated in Figure 9.

The size shall be at least 10 mm.



Figure 9

6.5 Refilling instructions

6.5.1 General

Refillable lighters shall be accompanied by specific instructions and warnings, as applicable, in accordance with 6.5.2 or 6.5.3, respectively.

6.5.2 Fluid lighters

Refillable fluid lighters as defined in 2.2 shall be accompanied by the substance of the following instructions:

- a) "Fill only with ... [type of fluid recommended by the manufacturer]".
- b) "Fill slowly. Do not overfill".
- c) "After filling, wipe lighter and hands dry before igniting".

(This instruction shall appear on a label attached to the lighter, or shall be printed directly on the lighter.)

6.5.3 Gas lighters

Refillable gas lighters shall be accompanied by specific printed instructions as to the correct procedure to accomplish the refill operation safely. These instructions shall indicate the fuel recommended by the manufacturer and include the appropriate information to ensure proper mating between the refill container and the fuel reservoir of the lighter.

7 Product marking

All lighters shall bear a permanent logo or name that identifies the manufacturer or distributor.

Annex A (informative)

Manufacturer's acceptance limits for specifications and inset limits for flame characteristics in 3.2.1 and 3.2.2

A.1 Finished lighters should comply with the following acceptance quality limits (AQLs). These AQLs call for measurement of flame height at the specification limit and a narrow (or inset) limit just below the specification limit.

A.2 For this purpose, AQL means the maximum percentage of finished product lying between or exceeding the specified limits acceptable as a process average. Manufacturers should ensure that percentages of finished product lying between or exceeding the specified limits are no greater than the following:

- | | |
|---|------|
| a) For non-adjustable fluid lighters as in 3.2.1.1: | |
| AQL for maximum flame height greater than 120 mm | 1 % |
| AQL for maximum flame height between 115 mm and 120 mm | 10 % |
| b) For non-adjustable postmixing and premixing burner lighters as in 3.2.1.2: | |
| AQL for maximum flame height greater than 50 mm | 1 % |
| AQL for maximum flame height between 40 mm and 50 mm | 10 % |
| c) For adjustable postmixing burner lighters as in 3.2.2.2: | |
| AQL for first-strike flame height above 100 mm | 1 % |
| AQL for first-strike flame height between 90 mm and 100 mm | 10 % |
| d) For adjustable postmixing burner lighters as in 3.2.2.3: | |
| AQL for maximum flame height above 120 mm | 1 % |
| AQL for maximum flame height between 115 mm and 120 mm | 10 % |
| e) For adjustable premixing burner lighters as in 3.2.2.4: | |
| AQL for first-strike flame height above 60 mm | 1 % |
| AQL for first-strike flame height between 50 mm and 60 mm | 10 % |
| f) For adjustable premixing burner lighters as in 3.2.2.5: | |
| AQL for maximum flame height above 75 mm | 1 % |
| AQL for maximum flame height between 65 mm and 75 mm | 10 % |

Bibliography

In order to meet the AQLs in Annex A, methods from, but not limited to, the following published documents may be used. Other custom-designed plans and statistical methods may be used at the manufacturer's discretion.

For inspection at the specification or inset limits, or both, separately:

- [1] ISO 2859-1:1999, *Sampling procedures for inspection by attributes — Part 1: Sampling schemes indexed by acceptance quality limit (AQL) for lot-by-lot inspection*

For inspection at the specification and inset limits, concurrently:

- [2] "Trinomial Sampling Plans to Match MIL-STD-105D", *1983 ASQC Quality Congress Transactions*, ASQC, Milwaukee, USA

Where flame height measurements are recorded and a stable normal distribution of product is established:

- [3] ISO 3951-1:2005, *Sampling procedures for inspection by variables — Part 1: Specification for single sampling plans indexed by acceptance quality limit (AQL) for lot-by-lot inspection for a single quality characteristic and a single AQL*

Where good process history has been established, and non-conforming units are removed from rejected lots, see the following AOQL tables:

- [4] *Sampling Inspection Tables — Single and Double Sampling*, Dodge and Romig, J. Wiley and Sons, Inc., New York, NY, USA

