

INTERNATIONAL STANDARD

ISO 9974-1

First edition
1996-04-15

Connections for general use and fluid power — Ports and stud ends with ISO 261 threads with elastomeric or metal-to-metal sealing —

Part 1: Threaded ports

*Raccordements pour applications générales et transmissions hydrauliques
et pneumatiques — Orifices et éléments mâles à filetage ISO 261 et joint
en élastomère ou étanchéité métal sur métal —*

Partie 1: Orifices filetés



Reference number
ISO 9974-1:1996(E)

Foreword

ISO (the International Organization for Standardization) is a worldwide federation of national standards bodies (ISO member bodies). The work of preparing International Standards is normally carried out through ISO technical committees. Each member body interested in a subject for which a technical committee has been established has the right to be represented on that committee. International organizations, governmental and non-governmental, in liaison with ISO, also take part in the work. ISO collaborates closely with the International Electrotechnical Commission (IEC) on all matters of electrotechnical standardization.

Draft International Standards adopted by the technical committees are circulated to the member bodies for voting. Publication as an International Standard requires approval by at least 75 % of the member bodies casting a vote.

International Standard ISO 9974-1 was prepared jointly by Technical Committees ISO/TC 5, *Ferrous metal pipes and metallic fittings*, Subcommittee SC 5, *Threaded or plain end butt-welding fittings, threads, gauging of threads*, and ISO/TC 131, *Fluid power systems*, Subcommittee SC 4, *Connectors and similar products and components*.

ISO 9974 consists of the following parts, under the general title *Connections for general use and fluid power — Ports and stud ends with ISO 261 threads with elastomeric or metal-to-metal sealing*.

- Part 1: *Threaded ports*
- Part 2: *Stud ends with elastomeric sealing (type E)*
- Part 3: *Stud ends with metal-to-metal sealing (type B)*

The performance requirements, dimensions and designs are defined for port and stud end connections for the L and S series in ISO 9974-2 and for the LL, L and S series in ISO 9974-3. Significant testing over more than 30 years of use has confirmed the performance requirements of these port and stud end connections.

Stud ends conforming to ISO 9974-2 and 9974-3 are identical to those conforming to DIN 3852-1. ISO 9974-2 stud ends are used on ISO 8434-1 and ISO 8434-4 fittings, and ISO 9974-3 stud ends are used on ISO 8434-1 fittings.

Annex A of this part of ISO 9974 is for information only.

© ISO 1996

All rights reserved. Unless otherwise specified, no part of this publication may be reproduced or utilized in any form or by any means, electronic or mechanical, including photocopying and microfilm, without permission in writing from the publisher.

International Organization for Standardization
Case Postale 56 • CH-1211 Genève 20 • Switzerland

Printed in Switzerland

Introduction

In fluid power systems, power is transmitted and controlled through a fluid (liquid or gas) under pressure within an enclosed circuit. In general applications, a fluid may be conveyed under pressure.

Components are connected through their threaded ports by fluid conductor fittings to tubes and pipes or to hose fittings and hoses.

Ports are an integral part of fluid power components, such as pumps, motors, valves, cylinders, etc.

Connections for general use and fluid power — Ports and stud ends with ISO 261 threads with elastomeric or metal-to-metal sealing —

Part 1: Threaded ports

1 Scope

This part of ISO 9974 specifies dimensions for ports with ISO 261 threads and elastomeric (type E) or metal-to-metal (type B) sealing for general use and in fluid power applications with the stud ends detailed in ISO 9974-2 and ISO 9974-3. It also specifies test methods and the designation of these ports.

Ports in accordance with this part of ISO 9974 may be used at working pressures up to 63 MPa (630 bar¹⁾). The permissible working pressure depends upon the port size, materials, design, working conditions, application, etc.

For threaded ports and stud ends specified in new designs in hydraulic fluid power applications, only ISO 6149 is to be used. Threaded ports and stud ends in accordance with ISO 1179, ISO 9974 and ISO 11926 are not to be used for new designs in hydraulic fluid power applications.

2 Normative references

The following standards contain provisions which, through reference in this text, constitute provisions of this part of ISO 9974. At the time of publication, the editions indicated were valid. All standards are subject to revision, and parties to agreements based on this part of ISO 9974 are encouraged to investigate the possibility of applying the most recent editions of the

standards indicated below. Members of IEC and ISO maintain registers of currently valid International Standards.

ISO 261:—²⁾, *ISO general-purpose metric screw threads — General plan.*

ISO 5598:1985, *Fluid power systems and components — Vocabulary.*

ISO 9974-2:1996, *Connections for general use and fluid power — Ports and stud ends with ISO 261 threads with elastomeric or metal-to-metal sealing — Part 2: Stud ends with elastomeric sealing (type E).*

ISO 9974-3:1996, *Connections for general use and fluid power — Ports and stud ends with ISO 261 threads with elastomeric or metal-to-metal sealing — Part 3: Stud ends with metal-to-metal sealing (type B).*

3 Definitions

For the purposes of this part of ISO 9974, the definitions given in ISO 5598 apply.

4 Dimensions

Ports shall conform to the dimensions shown in figure 1 and given in table 1.

1) 1 bar = 0,1 MPa = 10⁵ Pa; 1 MPa = 1 N/mm²

2) To be published. (Revision of ISO 261:1973)

Surface roughness in micrometres

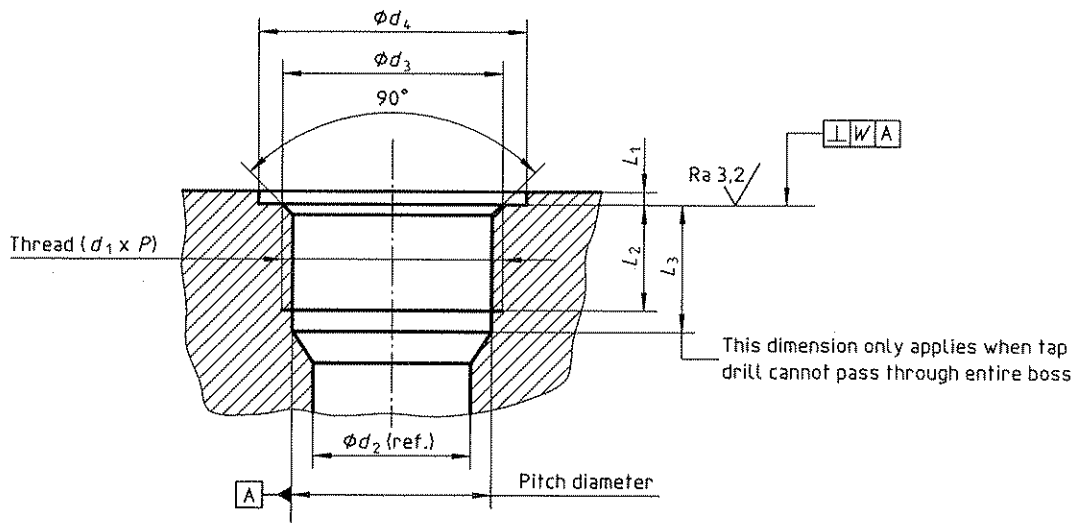

Figure 1 — Port

Table 1 — Port dimensions

Dimensions in millimetres

Thread ¹⁾ ($d_1 \times P$)	d_2 ref.	d_3		d_4 min.	L_1 max.	L_2 min.	L_3 ²⁾ min.	W
		nom.	tol.					
M8 × 1	3	8		13	1	8	10	0,1
M10 × 1	4,5	10		15	1	8	10	
M12 × 1,5	6	12		18	1,5	12	15	
M14 × 1,5	7	14		20	1,5	12	15	
M16 × 1,5	9	16		23	1,5	12	15	
M18 × 1,5	11	18	+0,2 0	25	2	12	15	
M20 × 1,5 ³⁾	10	20		27	2	14	17	
M22 × 1,5	14	22		28	2,5	14	17	
M26 × 1,5	18	26		33	2,5	16	19	
M27 × 2 ⁴⁾	16	27		33	2,5	16	20	
M33 × 2	23	33		41	2,5	18	22	0,2
M42 × 2	30	42	+0,3 0	51	2,5	20	24	
M48 × 2	36	48		56	2,5	22	36	

1) Conforming to ISO 261.

2) The tap drill depths given require the use of a bottoming tap to produce the specified full thread lengths. Where standard taps are used, the tap drill depths shall be increased accordingly.

3) For measurement applications.

4) M27 × 2 is used only in S (heavy-duty) series.

Annex A

(informative)

Bibliography

- [1] ISO 1101:1983, *Technical drawings — Geometrical tolerancing — Tolerances of form, orientation, location and run-out — Generalities, definitions, symbols, indications on drawings.*
- [2] ISO 1179-1:—³⁾, *Connections for general use and fluid power — Ports and stud ends with ISO 228-1 threads with elastomeric or metal-to-metal sealing — Part 1: Threaded ports.*
- [3] ISO 1179-2:—³⁾, *Connections for general use and fluid power — Ports and stud ends with ISO 228-1 threads with elastomeric or metal-to-metal sealing — Part 2: Heavy-duty (S series) and light-duty (L series) stud ends with elastomeric sealing (type E).*
- [4] ISO 1179-3:—³⁾, *Connections for general use and fluid power — Ports and stud ends with ISO 228-1 threads with elastomeric or metal-to-metal sealing — Part 3: Light-duty (L series) stud ends with sealing by O-ring with retaining ring (types G and H).*
- [5] ISO 1179-4:—³⁾, *Connections for general use and fluid power — Ports and stud ends with ISO 228-1 threads with elastomeric or metal-to-metal sealing — Part 4: Stud ends for general use only with metal-to-metal sealing (type B).*
- [6] ISO 1302:1992, *Technical drawings — Method of indicating surface texture.*
- [7] ISO 6149-1:1993, *Connections for fluid power and general use — Ports and stud ends with ISO 261 threads and O-ring sealing — Part 1: Ports with O-ring seal in truncated housing.*
- [8] ISO 6149-2:1993, *Connections for fluid power and general use — Ports and stud ends with ISO 261 threads and O-ring sealing — Part 2: Heavy-duty (S series) stud ends — Dimensions, design, test methods and requirements.*
- [9] ISO 6149-3:1993, *Connections for fluid power and general use — Ports and stud ends with ISO 261 threads and O-ring sealing — Part 3: Light-duty (L series) stud ends — Dimensions, design, test methods and requirements.*
- [10] ISO 6410-1:1993, *Technical drawings — Screw threads and threaded parts — Part 1: General conventions.*
- [11] ISO 8434-1:1994, *Metallic tube connections for fluid power and general use — Part 1: 24 degree compression fittings.*
- [12] ISO 8434-4:1995, *Metallic tube connections for fluid power and general use — Part 4: 24 degree cone connectors with O-ring weld-on nipples.*
- [13] ISO 11926-1:1995, *Connections for general use and fluid power — Ports and stud ends with ISO 725 threads and O-ring sealing — Part 1: Ports with O-ring seal in truncated housing.*
- [14] ISO 11926-2:1995, *Connections for general use and fluid power — Ports and stud ends with ISO 725 threads and O-ring sealing — Part 2: Heavy-duty (S series) stud ends.*
- [15] ISO 11926-3:1995, *Connections for general use and fluid power — Ports and stud ends with ISO 725 threads and O-ring sealing — Part 3: Light-duty (L series) stud ends.*
- [16] DIN 3852-1:1992, *Stud ends and tapped holes, with metric fine pitch thread, for use with compression couplings, valves and screw plugs — Dimensions.*

3) To be published.

ICS 23.100.30

Descriptors: hydraulic fluid power, pneumatic fluid power, fluid circuits, pipe fittings, pipe joints, standard couplings, screwed connections, ports (openings), seals (stoppers), specifications, dimensions, tests, designation.

Price based on 4 pages
