

INTERNATIONAL
STANDARD

ISO
9951

First edition
1993-12-01

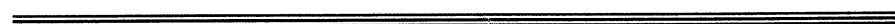

**Measurement of gas flow in closed
conduits — Turbine meters**

*Mesure de débit de gaz dans les conduites fermées — Compteurs à
turbine*



Reference number
ISO 9951:1993(E)

Contents

Page

1	Scope	1
2	Normative references	1
3	Definitions and symbols	1
3.1	Definitions	1
3.2	Symbols and subscripts	2
4	Principle of the method of measurement	3
5	Flowrates	3
6	Meter construction	3
6.1	General	3
6.2	Materials	3
6.3	Shell	3
6.4	Connections and maximum flowrates	3
6.5	Length	3
6.6	Pressure tapings	3
6.7	Flow direction	4
6.8	Meter having a removable meter mechanism	4
6.9	Overloading	4
6.10	Marking	4
7	Pressure testing	4
7.1	General	4
7.2	Test fluid	4
7.3	Strength test of the pressure-containing parts	4
7.4	Meter leakage test	5
8	Performance characteristics	5
8.1	Error	5

© ISO 1993

All rights reserved. No part of this publication may be reproduced or utilized in any form or by any means, electronic or mechanical, including photocopying and microfilm, without permission in writing from the publisher.

International Organization for Standardization
Case Postale 56 • CH-1211 Genève 20 • Switzerland

Printed in Switzerland

8.2	Calibration	5
8.3	Meter position	5
8.4	Temperature range	5
8.5	Pressure loss	5
8.6	Installation conditions	6
8.7	Mechanically driven external equipment	6
9	Output and readout	6
9.1	General	6
9.2	Counters	6
9.3	Flowrate output	6
9.4	Mechanical output	6
9.5	Voltage-free contact	6
9.6	Electrical pulse output	6
9.7	Electrical safety	6
 Annexes		
A	Recommendations for use	7
B	Other meter performance characteristics	9
C	Data computation and presentation	10
D	Field checks	11
E	Perturbations	12

Foreword

ISO (the International Organization for Standardization) is a worldwide federation of national standards bodies (ISO member bodies). The work of preparing International Standards is normally carried out through ISO technical committees. Each member body interested in a subject for which a technical committee has been established has the right to be represented on that committee. International organizations, governmental and non-governmental, in liaison with ISO, also take part in the work. ISO collaborates closely with the International Electrotechnical Commission (IEC) on all matters of electrotechnical standardization.

Draft International Standards adopted by the technical committees are circulated to the member bodies for voting. Publication as an International Standard requires approval by at least 75 % of the member bodies casting a vote.

International Standard ISO 9951 was prepared by Technical Committee ISO/TC 30, *Measurement of fluid flow in closed conduits*, Sub-Committee SC 10, *Turbine meters*.

Annexes A, B, C, D and E of this International Standard are for information only.

Measurement of gas flow in closed conduits — Turbine meters

1 Scope

This International Standard specifies dimensions, ranges, construction, performance, calibration and output characteristics of turbine meters for gas flow measurement.

It also deals with installation conditions, leakage testing and pressure testing and provides a series of informative annexes A to E including recommendations for use, field checks and perturbations of the fluid flowing.

In many countries, some or all of the items covered by this International Standard are subject to mandatory regulations imposed by the laws of these countries. In cases where conflict exists between such mandatory regulations and this International Standard, the former shall prevail.

2 Normative references

The following standards contain provisions which, through reference in this text, constitute provisions of this International Standard. At the time of publication, the editions indicated were valid. All standards are subject to revision, and parties to agreements based on this International Standard are encouraged to investigate the possibility of applying the most recent editions of the standards indicated below. Members of IEC and ISO maintain registers of currently valid International Standards.

ISO 3:1973, *Preferred numbers — Series of preferred numbers*.

ISO 4006:1991, *Measurement of fluid flow in closed conduits — Vocabulary and symbols*.

ISO 5167-1:1991, *Measurement of fluid flow by means of pressure differential devices — Part 1: Orifice plates, nozzles and Venturi tubes inserted in circular cross-section conduits running full*.

ISO 5168:1978, *Measurement of fluid flow — Estimation of uncertainty of a flow-rate measurement*.

ISO 5208:1993, *Industrial valves — Pressure testing of valves*.

ISO 6708:1980, *Pipe components — Definition of nominal size*.

IEC 79:—, *Electrical apparatus for explosive gas atmospheres*.

OIML R 6:1989, *General provisions for gas meters*.

OIML R 32:1989, *Rotary piston gas meters and turbine gas meters*.

VIM:1984, *International vocabulary of basic and general terms in metrology* (BIPM, IEC, ISO, OIML).

3 Definitions and symbols

3.1 Definitions

For the purposes of this International Standard, the definitions given in ISO 4006 and the International vocabulary of basic and general terms in metrology apply. The following definitions are given only for terms used in some special sense or for terms whose meaning it seems useful to recall.

3.1.1 flowrate: Actual volume of flow per unit of time.

3.1.2 working range: Range of flowrates of gas limited by the maximum flowrate q_{\max} and the minimum flowrate q_{\min} , for which the meter error lies within specified limits (sometimes also called "rangeability").

3.1.3 metering pressure: Gas pressure in a meter to which the indicated volume of gas is related.

3.1.4 average velocity: Volume flowrate per unit of cross-sectional area.

3.1.5 shell: Pressure-containing structure of the meter.

3.1.6 metering conditions: Conditions, at the point of measurement, of the gas whose volume is to be measured (for example gas temperature and pressure).

3.1.7 base conditions: Conditions to which the measured volume of the gas is converted (for example base temperature and base pressure).

3.1.8 specified conditions: Conditions of the gas at which performance specifications of the meter are given.

NOTE 1 Metering and base conditions relate only to the volume of the gas to be measured or indicated, and should not be confused with "rated operating conditions" or "reference conditions" (VIM 5.05 and 5.07), which refer to influence quantities (VIM 2.10).

3.2 Symbols and subscripts

The symbols and subscripts used in this International Standard are given in table 1.

Table 1 — Symbols and subscripts

Symbol	Quantity	Dimensions ¹⁾	SI unit
<i>c</i>	Pressure loss coefficient depending on meter type	L ⁻⁴	m ⁻⁴
<i>d</i>	Relative density of the gas ($d_{air} = 1$)	Dimensionless	—
<i>D</i>	Inside diameter meter outlet/inlet	L	m
<i>D</i> ₁	Inside diameter pipe	L	m
DN	Nominal size meter outlet/inlet	Dimensionless	—
DN ₁	Nominal size pipe	Dimensionless	—
<i>H</i>	Height of strut	L	m
<i>L</i>	Length of the strut	L	m
<i>m</i>	Mass	M	kg
<i>M</i>	Molar mass	M	kg/mol
<i>N</i>	Number of moles of gas		mol
<i>p</i>	Absolute pressure	ML ⁻¹ T ⁻²	Pa
<i>p</i> _m	Metering pressure	ML ⁻¹ T ⁻²	Pa
<i>q</i>	Flowrate	L ³ T ⁻¹	m ³ /s
<i>R</i>	Molar gas constant	ML ² T ⁻² Θ ⁻¹	J/(mol·K)
<i>S</i>	Chord distance between adjacent struts measured at the tip	L	m
<i>t</i>	Time	T	s
<i>T</i>	Absolute temperature of the gas	Θ	K
<i>V</i>	Volume	L ³	m ³
<i>Z</i>	Compressibility factor (deviation from ideal gas laws)	Dimensionless	—
<i>ρ</i>	Density of the gas	ML ⁻³	kg/m ³
<i>ψ</i>	Working range q_{max}/q_{min}	Dimensionless	—
Subscripts			
b	Base conditions for volume or rate calculations		
m	Metering conditions of the gas		
s	Specified conditions for volume or rate		
1) M = mass; L = length; T = time; Θ = temperature.			

4 Principle of the method of measurement

The turbine meter is a fluid measuring device in which the dynamic forces of the flowing fluid cause the turbine wheel to rotate with a speed approximately proportional to the rate of volume flow. The number of revolutions of the turbine wheel is the basis for the indication of the volume passed through the meter.

5 Flowrates

The maximum and minimum flowrates shall be specified for the gas densities for which the meter will operate within the specifications of meter performance defined in clause 8. The maximum flowrate in cubic metres per hour (m^3/h) of the meter should preferably be a number in the set R5 of preferred numbers specified in ISO 3 (the value 63 has been rounded to 65). The unit of cubic metres per hour (m^3/h) is preferred.

6 Meter construction

6.1 General

Meters shall be designed and manufacturing tolerances shall be set to allow interchangeability of meters of the same size and type.

6.2 Materials

The meter body and the internal mechanism shall be manufactured of materials suited for the service conditions and resistant to attack by the fluid which the meter is to handle. Exterior surfaces of the meter shall be protected as necessary against corrosion.

6.3 Shell

The meter shell and all other parts comprising the fluid-containing structure of the meter shall be constructed of sound materials and designed to handle the pressures and temperatures for which they are rated.

6.4 Connections and maximum flowrates

The inlet and outlet connections of the meter shall conform to recognized standards.

The preferred nominal sizes (DN) and corresponding maximum flowrates (q_{max}) are given in table 2.

Table 2 — Maximum flowrates and nominal sizes

Maximum flowrates, q_{max}	Nominal size
m^3/h	DN
40	50
65	50
100	50
160	80
250	80
400	100
650	150
1 000	150
1 600	200
2 500	250
4 000	300
6 500	400
10 000	500
16 000	600
25 000	750
40 000	1 000

6.5 Length

The length of the meter between the ends of its inlet and outlet connections shall be less than or equal to $5D$.

6.6 Pressure tapings

6.6.1 Metering-pressure tapings

At least one metering-pressure tapping shall be provided on the meter, to enable measurement (indirectly if necessary) of the static pressure at the turbine wheel of the meter at metering conditions. The connection of this pressure tapping shall be marked " p_m ". If more than one " p_m " tapping is provided, the difference in pressure readings shall not exceed 100 Pa at maximum flowrate with an air density of $1,2 \text{ kg}/\text{m}^3$.

6.6.2 Other pressure tapings

A meter may be equipped with other pressure tapings in addition to the " p_m " tapping. These may serve to determine the pressure drop over a part of the meter or for other purposes. The other pressure tapings shall be marked " p ".

6.6.3 Dimensions

6.6.3.1 Circular tappings shall conform to the requirement given in ISO 5167-1 except that they shall have a minimum bore diameter of 3 mm and a maximum bore diameter of 12 mm, and the length of the bore shall be a minimum of one bore diameter.

6.6.3.2 Slit-shaped tappings shall have a minimum dimension of 2 mm and a maximum dimension of 10 mm in the direction of flow, and a minimum cross-sectional area of 10 mm².

6.6.4 Sealing

Any pressure test point or tapping connection on the meter shall be provided with a suitable means of closure, e.g. a plug, and shall be capable of being sealed against unauthorized interference.

6.7 Flow direction

The direction of flow or the inlet of the meter shall be clearly and permanently marked.

6.8 Meter having a removable meter mechanism

6.8.1 The construction of a meter with a removable meter mechanism shall be such that the performance characteristics of the meter as defined in 8.1 are maintained after interchange of the mechanism and/or after repeated mounting and dismounting of the same mechanism.

6.8.2 The design and method of replacement of a removable mechanism shall ensure that the construction of the meter as specified in this clause is maintained.

6.8.3 Each removable meter mechanism shall have a unique serial number marked on it.

6.8.4 Each removable meter mechanism shall be capable of being sealed against unauthorized interference.

6.9 Overloading

The meter shall be designed to be capable of occasionally running 20 % above the maximum flowrate, within the range of pressure and temperature for which it is rated, for a time period of 30 min without damage or without influence on the error curve of the meter.

6.10 Marking

The badge of the meter shall be marked with at least the following information:

- a) manufacturer's name or mark;
- b) serial number;
- c) maximum flowrate, q_{max} , in actual volume units;
- d) maximum allowable operating pressure;
- e) minimum flowrate, q_{min} , at 1,2 kg/m³ fluid density.

7 Pressure testing

7.1 General

7.1.1 The pressure testing shall be based on the shell test for industrial valves as specified in ISO 5208.

7.1.2 Meters shall not be painted or otherwise coated with materials capable of sealing against leakage before leakage tests are completed. Chemical corrosion protection treatments and internal linings are permitted. If pressure tests in the presence of a representative of the purchaser are specified, painted meters from stock may be retested without removal of paint.

7.1.3 Test equipment shall not subject the meter to externally applied stress which may affect the results of the tests.

7.2 Test fluid

7.2.1 At the discretion of the testing facility the tests can be carried out with water, kerosine, or any other suitable liquid having a viscosity not greater than that of water or with gas (air or any other suitable gas).

7.2.2 When testing with a liquid, the meter shall be thoroughly purged of any air which it contains.

7.3 Strength test of the pressure-containing parts

7.3.1 The test shall be performed at a minimum internal pressure of 1,5 times the maximum allowable operating pressure at 20 °C (nominal).

7.3.2 The test shall be performed by applying pressure inside the pressure-retaining walls of the assembled meter with the connections closed.

7.3.3 Visually detectable leakage through the pressure-retaining walls is not acceptable.

The test duration shall not be less than that specified in table 3.

Table 3 — Strength test duration

Nominal size, DN	Minimum test duration
	s
DN = 50	15
50 < DN ≤ 200	60
DN > 200	180

7.4 Meter leakage test

The assembled meter shall be pneumatically tested for external leakage at a minimum internal pressure of 1,1 times the maximum allowable operating pressure. The pressure shall be increased slowly up to the test pressure and shall be maintained there for a minimum of 1 min. During this period no fluid shall escape from the meter. If a leakage test is run after a hydrostatic test, a water seal could develop, therefore the meter should be dried before assembling the mechanism and carrying out the leak test. After the test, the pressure shall be released at a rate not greater than that used for pressurization.

8 Performance characteristics

See also annex B.

8.1 Error

The relative error, E , in percent, is defined as the ratio of the difference between the indicated value V_{ind} and the conventional true value V_{true} of the volume of the test medium which has passed through the gas meter, to this latter value:

$$E = \frac{V_{ind} - V_{true}}{V_{true}}$$

All meters shall have a maximum permissible error of $\pm 1\%$ over the designated flow range. When q_{min} is less than $0,2 q_{max}$, the maximum permissible error between q_{min} and $0,2 q_{max}$ is $\pm 2\%$.

A meter is considered to satisfy this requirement if it is met at the flowrates specified in 8.2.1.

The density range for which the relative errors are within these allowances shall be specified.

For the calculation of errors, see also ISO 5168.

8.2 Calibration

An individual calibration of each meter shall be made. The results of this calibration shall be available on request, together with a statement of conditions under which the calibration took place.

8.2.1 Calibration data

The calibration data provided shall include:

- the error at q_{min} and all the following flowrates that are above q_{min} :
0,1; 0,25; 0,4; 0,7 of q_{max} and q_{max} ;
- the name and location of the calibration facility;
- the method of calibration (bell prover, sonic nozzles, other meters, etc.);
- the estimated uncertainty of the method;
- the nature and conditions (pressure and temperature) of the test gas;
- the position of the meter (horizontal, vertical flow upwards, vertical flow downwards).

8.2.2 Calibration conditions

The calibration is preferably carried out at conditions as close as possible to operating conditions.

8.2.3 Calibration facility

The facility at which the calibration is carried out shall be traceable to the primary standards of mass, length, time and temperature.

8.2.4 Installation conditions at calibration

The performance of the meter shall not be influenced by the installation conditions of the test facility.

8.3 Meter position

The position in which the meter is mounted to achieve the specified performance shall be stated. The following positions shall be considered: horizontal; vertical flow upwards, or vertical flow downwards. If a mechanical output and/or mechanical counter is used, the different possible positions of these devices shall be taken into consideration when specifying the meter position.

8.4 Temperature range

The fluid and ambient temperature ranges over which the meter is designed to perform within standard performance specification shall be stated.

8.5 Pressure loss

Pressure loss data for the meter shall be provided (see annex B). Apart from the pressure loss across the meter, the pressure loss in adjacent pipework and flow conditioners necessary to satisfy the require-

ments for performance limits shall be taken into account.

8.6 Installation conditions

The conditions for the installation of the meter shall be specified in order that the relative meter error does not differ by more than one third of the maximum permissible error specified in 8.1 from the meter error obtained with an undisturbed upstream flow condition. Consideration shall be given to such items as the straight lengths of pipe upstream and/or downstream of the meter, and/or the type and location of a flow conditioner if required (see annex E).

8.7 Mechanically driven external equipment

If an output shaft is provided which drives instrumentation other than the normal mechanical counter, loading of this shaft will retard the meter. This effect is largest for small flowrates and low gas densities. Therefore, the meter specifications shall state the maximum torque which may be applied by the output shaft and the effect of this torque on the meter performance for different densities, as well as the range of flowrates for which this statement is valid.

9 Output and readout

9.1 General

The output of the meter consists of an electrical or mechanical counter totalling the throughput of the meter. An electrical pulse rate signal or a rotating shaft may be used to represent the flowrate through the meter.

9.2 Counters

9.2.1 Counter capacity

The number of digits in a counter shall be sufficient to indicate, to within one unit of the last digit, a throughput volume corresponding to at least 2 000 hours of operation at the maximum flowrate.

9.2.2 Units

The counter shall indicate the throughput of the meter in SI units or units directly derived from SI units. On the counter the units used shall be clearly and unambiguously stated.

9.2.3 Numbers

The height of the numerals of the counter shall be a minimum of 4 mm. The change of numerals shall be such that the advance of one figure at any point of the

counter must be completed while the figure of the next lower range describes the last tenth of its course.

9.2.4 Construction

Counters shall be of good design and reliable construction. When mounted on the turbine meter they are required to operate reliably and remain legible over the entire temperature range (see 8.4).

9.2.5 Smallest division of the counter

When the only output of the meter is a mechanical counter, the readout shall enable the meter to be calibrated with the required accuracy at the minimum flowrate in a reasonably short time. The smallest division of the least significant digit of the counter or test element should therefore be smaller than the minimum hourly flowrate divided by 400.

9.3 Flowrate output

The flowrate output of the meter, whether it is in the form of a pulse rate or the rotational speed of a shaft, shall be in a known ratio to the rate of change in the counter.

9.4 Mechanical output

Provision shall be made for covering and sealing the free ends on any extra output shafts, when they are not being used. The value per revolution of an output shaft, expressed as $1 \text{ rev} \triangleq \dots \text{ m}^3$ (see OIML R6), and the direction of rotation shall be marked on the shaft or on an adjacent point on the meter.

9.5 Voltage-free contact

If a voltage-free contact is provided, its operation shall represent a volume being a decimal submultiple of, equal to, or a decimal multiple of the volume indicated per revolution of the driven part of the counter. The value of the pulse shall be clearly indicated on the meter.

9.6 Electrical pulse output

The number of pulses per cubic metre indicated by the counter shall be stated on the meter. The number of pulses representing a cubic metre (the meter factor) on meters without mechanical indexes shall be defined for the flowrates given in 8.2.1.

9.7 Electrical safety

Meters equipped with electrical or electronic equipment shall satisfy IEC 79 if intended for use with combustible gas or in a hazardous atmosphere.

Annex A (informative)

Recommendations for use

A.1 General

Turbine meters should be operated within the specified flow range and operating conditions to achieve the desired accuracy and normal lifetime. Premature wear and damage may be caused by turbine wheel overspeed and the presence of debris in the pipeline. Key considerations for successful operation are appropriate meter size for the intended flow, correct installation, and proper operation and maintenance procedures.

A.2 Start-up recommendation for new lines

Before starting up a meter installation, particularly on new lines or lines that have been repaired, the line should first be cleaned to remove any collection of welding beads, rust accumulation and other pipeline debris. The meter mechanism should be removed during all hydrostatic testing and such line cleaning operations to prevent serious damage to the meter measuring element.

A.3 Strainers or filters

A.3.1 Foreign substances in a pipeline can seriously damage turbine meters. Strainers are recommended when the presence of damaging foreign material in the gas stream can be anticipated. Strainers should be sized so that at maximum flow there is a minimum pressure drop and installed so that there is no undue flow distortion (see annex E).

A.3.2 A greater degree of meter protection can be achieved through the use of a dry-type or separator-type filter installed upstream of the meter inlet piping.

A.3.3 It is recommended that the pressure differential across a filter be monitored to ensure that the filter remains in good condition and that flow distortion is prevented.

A.4 Overrange protection

Turbine meters can generally withstand a gradual overranging without suffering internal damage other than accelerated wear. However, extreme gas velocity encountered during pressurizing, venting or

purging can cause severe damage to the meter due to the resulting sudden turbine wheel overspeed.

A.4.1 As with all meters, turbine meters should be pressurized and started up slowly. Shock loading by opening valves quickly will usually result in turbine wheel damage. In high pressure applications, the installation of a small bypass line around the upstream meter-isolating valve can be utilized to safely pressurize the meter to its operating pressure.

A.4.2 In installations where adequate pressure is available, either a critical flow orifice or a sonic Venturi nozzle may be installed to help protect the meter turbine wheel from overspeeding. The restriction should be installed in the piping downstream of the meter and should be sized to limit the meter loading to approximately 20 % above its q_{max} . Generally, a critical flow orifice will result in a 50 % pressure loss and a sonic Venturi nozzle will result in a 5 % to 20 % pressure loss.

A.5 Bypass

If interruption of the gas supply cannot be tolerated, a bypass should be installed so that the meter can be maintained.

A.6 Frequency of maintenance and inspection

Turbine meter accuracy, in addition to depending on sound design and installation procedures, is dependent on good maintenance practice and adequate frequency of inspection. Basically, the time between meter inspections is dependent on the gas conditions. Meters used in dirty gas applications will require more frequent attention than those used with clean gas, and inspection periods should reflect this aspect.

A.7 Other installation considerations

In addition to the above-mentioned items, it is also necessary to take the following installation practices into consideration, as the lack of attention to any one item could result in serious measurement errors.

- a) The meter and meter piping should be installed so as to minimize strain on the meter due to pipeline stresses.

- b) Use care to ensure a concentric alignment of the pipe connections with the meter inlet and outlet connections.
- c) Prevent gasket and/or weld bead protrusion into the bore, which could disturb the flow pattern.
- d) If liquid could be encountered, installations should be sloped to provide continual draining of the meter, or the meter should be installed in the vertical position. In cases where a considerable quantity of liquid is expected, it is recommended that a separator be installed upstream of the meter. Flow distortion by the separator should be taken into consideration in the piping recommendation.
- e) Turbine meters should not be used where frequently interrupted and/or strongly fluctuating flow or pressure pulsations are present.

A.8 Installation of accessories

Accessory devices used for converting the indicated volume to baseline conditions or for recording operating parameters should be installed properly and the connections made as follows:

A.8.1 Temperature measurement

Since upstream disturbances should be kept to a minimum, the recommended location for a thermometer well is downstream of the turbine wheel. It should be located as closely as possible downstream of the turbine wheel, but within 5 pipe diameters from the turbine wheel and upstream of any outlet valve or flow restrictions. The thermometer well should be installed such that the temperature measured is the real temperature corresponding to flowrates between q_{\min} and q_{\max} and is not influenced by heat transfer from the piping or well attachment.

A.8.2 Pressure measurement

The pressure tapping marked " p_m " on the meter body should be used as the pressure sensing point for recording or integrating instruments.

A.8.3 Density measurement

The conditions of the gas in the density meter should represent the conditions in the turbine wheel over the operating flowrates of the meter. Consideration should be given to the possible presence of unmetered gas when using purged density meters. Density meters installed in the piping should preferably be installed downstream of the turbine wheel.

Annex B (informative)

Other meter performance characteristics

B.1 Gas conditions

Generally, it is desirable to know the quantity of gas in terms of mass or in terms of volume at certain conditions. In all cases this quantity is derived from the measurement of volume at metering conditions, taking into account the meter reading and measurement of the metering conditions.

B.1.1 Metering conditions

See 3.1.6.

Symbols related to these conditions have the subscript "m".

B.1.2 Specified conditions

See 3.1.8.

Symbols related to these conditions have the subscript "s".

B.1.3 Baseline conditions

See 3.1.7.

Symbols related to these conditions have the subscript "b".

B.2 Pressure loss

The pressure loss over a turbine meter is determined by the energy required for driving the meter mechanism, the losses due to friction of internal passage, and changes in flow velocity and direction. The pressure loss is measured between a point one pipe diameter upstream and a point one pipe diameter downstream of the meter on piping of the same size as that of the meter. Care should be taken in selecting and manufacturing the pressure points to ensure that flow pattern distortions do not affect the pressure readings.

The pressure loss basically follows the turbulent flow loss relationship (except at very low flowrates):

$$\Delta p_m = c \rho_m q_m^2 \quad \dots (B.1)$$

From pressure loss at specified conditions and from the equation of state of an ideal gas, it follows that:

$$\Delta p_m = \Delta p_s \left(\frac{\rho_m}{\rho_s} \right) \left(\frac{q_m}{q_s} \right)^2 \quad \dots (B.2)$$

and

$$\Delta p_m = \Delta p_s \left(\frac{d_m}{d_s} \right) \left(\frac{p_m}{p_s} \right) \left(\frac{T_s}{T_m} \right) \left(\frac{Z_s}{Z_m} \right) \left(\frac{q_m}{q_s} \right)^2 \quad \dots (B.3)$$

B.3 Maximum and minimum flowrates

Gas turbine meters are generally designed for a maximum flowrate, q_{max} , in order not to exceed a certain turbine wheel speed and a certain pressure loss. This maximum flowrate of the meter remains the same, unless stated otherwise, for all metering conditions up to the stated maximum allowable operating pressure.

From the minimum flowrate, pressure, temperature and fluid composition as specified by the manufacturer, the minimum flowrate can be written as:

$$q_{m,min} = q_{s,min} \sqrt{\frac{\rho_s}{\rho_m}} \quad \dots (B.4)$$

B.4 Working range

Since the maximum flowrate generally does not change and the minimum flowrate can change (see B.3), the working range, ψ , of a gas turbine meter changes essentially with the square root of the gas density:

$$\psi_m = \psi_s \sqrt{\frac{\rho_m}{\rho_s}} \quad \dots (B.5)$$

B.5 Effects of temperature and pressure

Changes in meter performance can occur when the operating temperature and pressure are very different from the calibration conditions (see 8.2.2). These changes may be due to changes in dimensions, bearing friction or to physical phenomena.

Annex C (informative)

Data computation and presentation

C.1 Equations for volume calculation

Since the turbine meter measures volumes at metering conditions, the equation of state of ideal gases may be applied to convert the indicated volume to a volume at baseline conditions, when these conditions are constant.

The following equations convert the gas volume indicated by the gas turbine meter at metering conditions into gas volume at baseline conditions (baseline pressure and baseline temperature):

for metering conditions

$$p_m V_m = Z_m N R T_m \quad \dots (C.1)$$

and for baseline conditions

$$p_b V_b = Z_b N R T_b \quad \dots (C.2)$$

Since R is a constant for the gas regardless of pressure and temperature, for a number of moles N of gas, the two equations can be combined to yield:

$$V_b = V_m \left(\frac{p_m}{p_b} \right) \left(\frac{T_b}{T_m} \right) \left(\frac{Z_b}{Z_m} \right) \quad \dots (C.3)$$

Equation (C.3) can be used for the specific conditions at the meter.

For non-constant metering conditions:

$$V_b = \int q_m \left(\frac{p_m}{p_b} \right) \left(\frac{T_b}{T_m} \right) \left(\frac{Z_b}{Z_m} \right) dt \quad \dots (C.4)$$

C.2 Equations for calculation of mass

The mass is calculated from the product of the volume of metered gas and the density of the gas.

Gas at constant density

$$m = V_b \rho_b = V_m \rho_m \quad \dots (C.5)$$

Gas at varying densities

$$m = \int q_m \rho_m dt \quad \dots (C.6)$$

$$\frac{p_m}{\rho_m} = Z_m (R/M) T_m \quad \dots (C.7)$$

The densities ρ_m and ρ_b may be determined by measurement or by computation from the composition and conditions of the gas.

C.3 Presentation of calibration data

The meter calibration data should be plotted as a function of the actual flowrate, baseline flowrate or pipe Reynolds number. The actual or baseline flow conditions for pressure and temperature as well as the test fluid should be stated in the calibration data.

Annex D (informative)

Field checks

D.1 General

The most commonly applied field checks for turbine meters are visual inspection and the spin time test. Information can often be gained from meters in operation by observing the noise or vibrations generated.

Severe vibration of the meter usually indicates damage which has unbalanced the turbine wheel; this may lead to complete meter failure. Turbine wheel rubbing and poor bearings can often be heard at relatively low flowrates at which such noises are not masked by normal flow noise.

D.2 Visual inspection

During visual inspection, the turbine wheel should be inspected for missing blades, accumulation of solids, erosion or other damage that would affect the turbine wheel balance and the blade configuration. Meter internals should also be checked to ensure there is no accumulation of debris.

Flow passageways, drains, breather holes and lubrication systems should also be checked to ensure that debris has not accumulated.

D.3 Spin time test

The spin time test determines the relative level of the mechanical friction present in the meter in relation to a previous test. If the mechanical friction has not significantly changed, if the meter area is clean, and if the internal portions of the meter show no damage, the meter should display no change in accuracy. A significant increase in the mechanical friction indicates that the accuracy characteristic of the meter at low flowrates has degraded. Typical spin times for meters can be provided by the manufacturer on request.

The spin time test must be conducted in a draught-free area with the measuring mechanism in its normal operating position. The turbine wheel is rotated at a

reasonable speed, i.e. a minimum speed of approximately 1/20 of the rated speed corresponding to q_{max} , and is timed from the initial motion until the turbine wheel stops.

Spin tests should be repeated at least three times and the average time taken. The usual cause for a decrease in spin time is increased turbine wheel shaft bearing friction. It should be noted, however, that there are other causes of mechanical friction which affect spin time, such as heavily lubricated bearings, low ambient temperature, draughts and attached accessories.

NOTE 2 Other methods of conducting a spin time test are possible, as long as the method is specified.

D.4 Other checks

Meters equipped with pulse generators at the turbine wheel provide the possibility to detect the loss of a blade on the wheel. This may be accomplished by observing the output pulse pattern or comparing the pulse output from the turbine wheel pulse generator to a pulse generator on a follower disc connected to the turbine wheel shaft.

A pulse generator activated by the turbine wheel blading or any other place in the drive train between the turbine wheel and the meter index can be used in conjunction with a pulse generator on the index to determine the integrity of the drive train. The ratio of a low frequency pulse from the index to a high frequency pulse generated from any place further down the drive train should be a constant regardless of flowrate.

Certain volume conversion devices attached to turbine meters also indicate volumes at flow conditions. The change in the registered volume on the conversion device should equal the change in registered volume on the mechanical index of the turbine meter over the same period of time.

Annex E (informative)

Perturbations

E.1 General

This annex provides guidance for flow disturbances that may affect meter performance and standardized tests to assess the effects of such disturbances.

E.2 Swirl effect

If the fluid at the meter inlet has significant swirl, the turbine wheel speed may be influenced. A swirl at the turbine wheel in the direction of rotation increases the turbine wheel speed, whereas a swirl in the opposite direction decreases the turbine wheel speed. For high accuracy flow measurement, such a swirl effect should be reduced to an insignificant level by proper installation of the meter.

E.3 Velocity profile effect

The gas turbine meter is designed for and calibrated under conditions which approach a uniform velocity profile at the meter inlet. In the case of significant deviation from this profile, the turbine wheel speed at a given flowrate can be affected by the actual velocity profile at the turbine wheel. For a given average flowrate, a non-uniform velocity profile generally results in a higher turbine wheel speed than a uniform velocity profile. For high-accuracy flow measurement, the velocity profile at the turbine wheel should be ensured to be essentially uniform by proper installation of the meter.

E.4 Perturbation testing

E.4.1 Tests

Tests to determine the sensitivity of a meter to installation conditions can be carried out at close to atmospheric conditions with air flowrates of $0,25 q_{\max}$, $0,4 q_{\max}$ and q_{\max} .

The installations that satisfy the specifications in 8.6 should be described for each meter.

E.4.2 Low level perturbations

The piping configurations shown in figure E.1 [a) and b)] consisting of a pipe with nominal size DN_1 and length of $5D_1$, two elbows of diameter equal to D_1 in two perpendicular planes, and a concentric expander from DN_1 to DN and a length between D and $1,5D$ can be considered to be representative of low level perturbations produced by piping elements such as bends, tees, convergent and divergent sections.

The values of DN_1 are listed in table E.1.

Nominal sizes of pipe components are defined in ISO 6708.

Table E.1 — Relationship of DN_1 to DN

Meter DN	Pipe DN_1
50	40
80	50
100	80
150	100
200	150
250	200
300	250
400	300
500	400
600	500
750	600
1 000	750

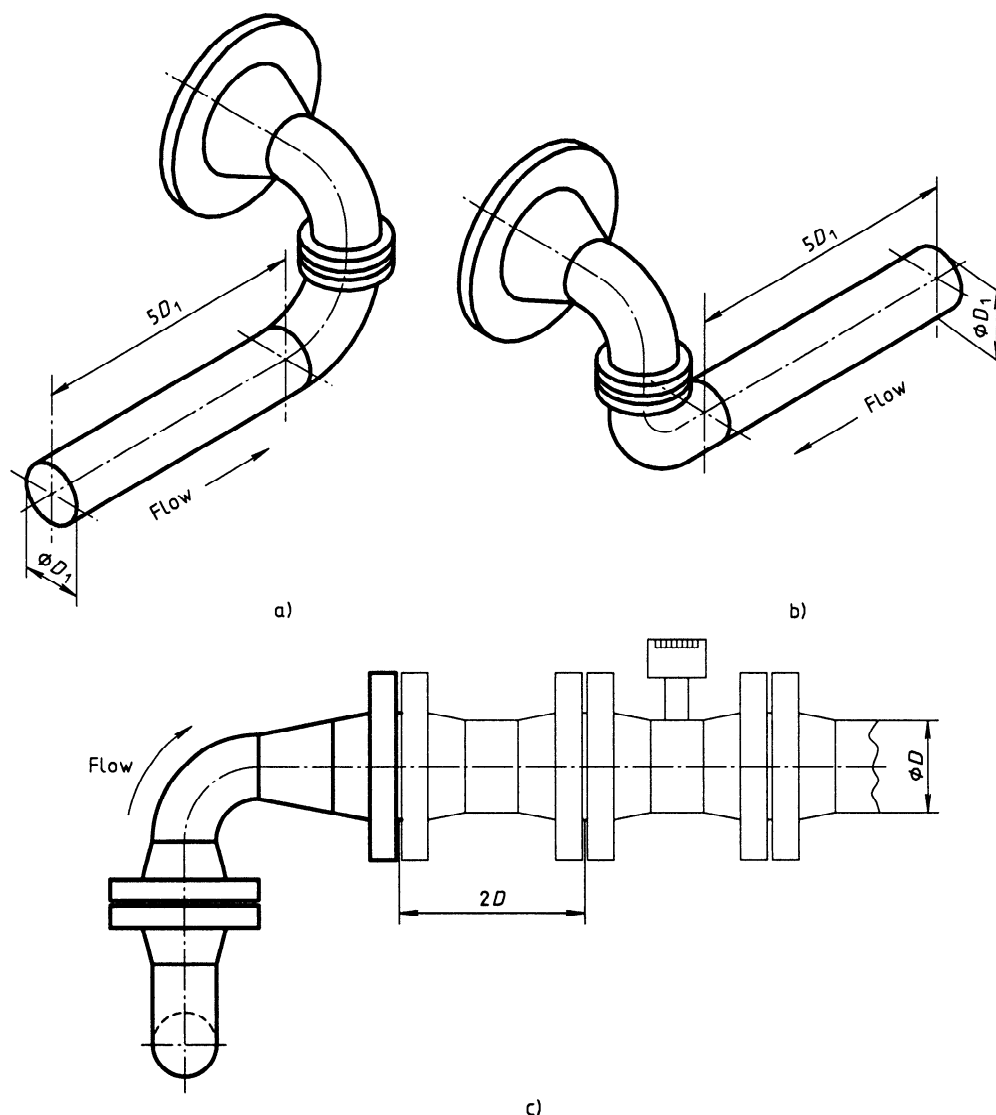

Figure E.1 — Piping configurations for tests at low level perturbation

E.4.2.1 If the elements shown in figure E.1 [a) and b)], installed $2D$ upstream of the meter inlet [see figure E.1 c)] cause an error shift at atmospheric conditions not exceeding the difference mentioned in 8.6, no flow conditioner or additional length of upstream pipe is required in service if only low level perturbations occur at a distance of $2D$ or more upstream of the meter inlet.

E.4.2.2 If the error difference is greater than the value given in 8.6, tests should be carried out with a longer upstream straight pipe and/or flow conditioner, preferably of the types mentioned in ISO 5167-1, to determine the inlet section configuration necessary to

keep the error differences within the limits given in 8.6. The flow conditioner should be installed in pipe of diameter D with the end of the flow conditioner at least $2D$ from the meter inlet.

E.4.3 High level perturbations

E.4.3.1 To determine the sensitivity of a meter to high level perturbations caused by regulators or other throttling devices, tests should be carried out with the piping configurations shown in figure E.1, but with a half-pipe area plate as shown in figure E.2 installed between the two elbows, with the opening toward the outside radius of the first bend.

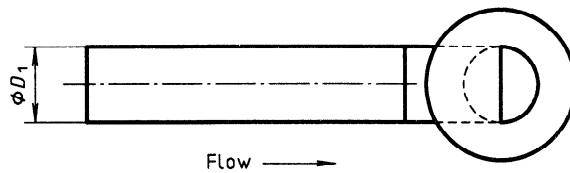

Figure E.2 — Location of half-area opening for tests at high level perturbation

E.4.3.2 If the error difference is greater than that stated in 8.6, the procedure described in E.4.2.2 should be carried out to determine the upstream configuration that satisfies the requirements of 8.6.

E.4.3.3 These tests are not representative of all situations where a regulator produces a strong eccentric outlet jet. Great care is needed when turbine meters are used downstream of regulators operating with large pressure reductions. Also, for piping systems having an unknown potential influence on meter

performance, it is recommended that a flow conditioner as shown in figure E.3 be installed at a minimum of $4D$ from the conditioner outlet to the meter inlet connection.

NOTE 3 A flow conditioner of this type causes a relatively large pressure loss. In those cases where such a pressure loss can be handled, installation of such a flow conditioner is advised downstream of a regulator.

In those cases where the pressure drop across the flow conditioner in figure E.3 cannot be tolerated, installation of a flow conditioner as shown in figure E.4 may also be used.

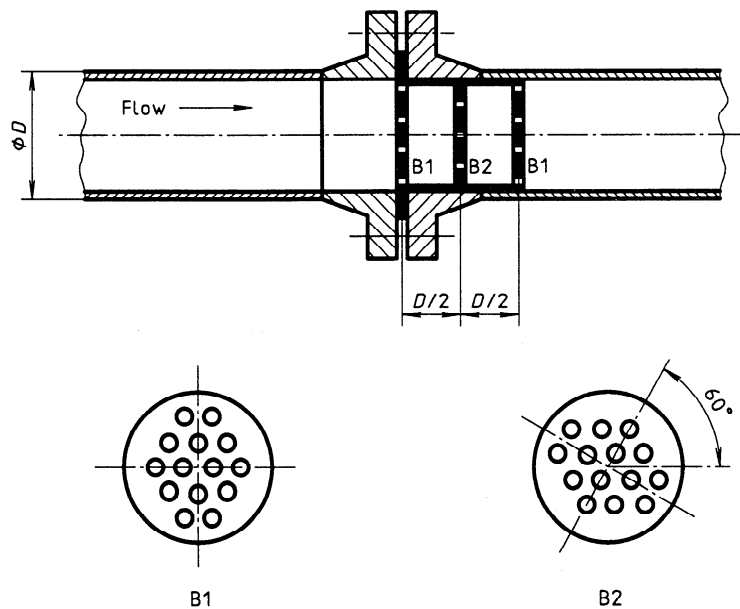

NOTE — Free area: 20 % of pipe area. For this area ratio, the pressure loss at q_{max} is approximately 0,07 times the static pressure for a nominal pipe diameter DN according to 6.4 and for a relative gas density of 0,64.

The hole pattern should be such that the holes on adjacent plates do not provide a straight path for the flowing fluid.

The perforated plates are attached to a sleeve such that all fluid passes through the plates.

Figure E.3 — Flow conditioner to damp out high level perturbation

E.5 Similarity

If similarity of design exists in the meter inlet section for various size meters, a minimum of two meter sizes should be tested. If the results are similar, it can

be assumed other meter sizes would produce the same results. Similarity can be assumed to exist if the values of H/D and S/L for any meter are equal to or less than those for the tested meters (see figure E.5).

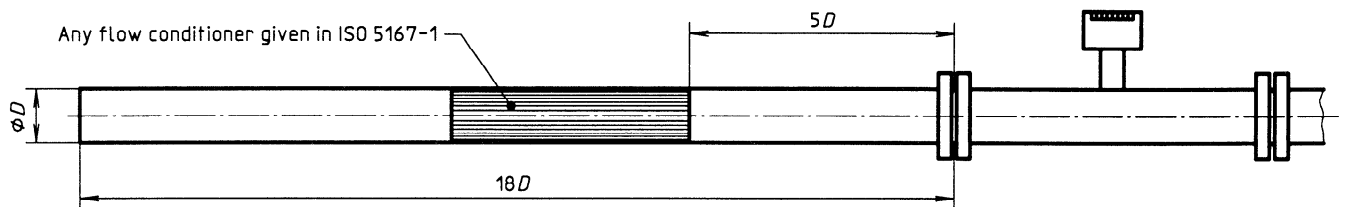

NOTE — The straight lengths specified are minimum values.

Figure E.4 — Alternative flow conditioner configuration to damp out high level perturbation

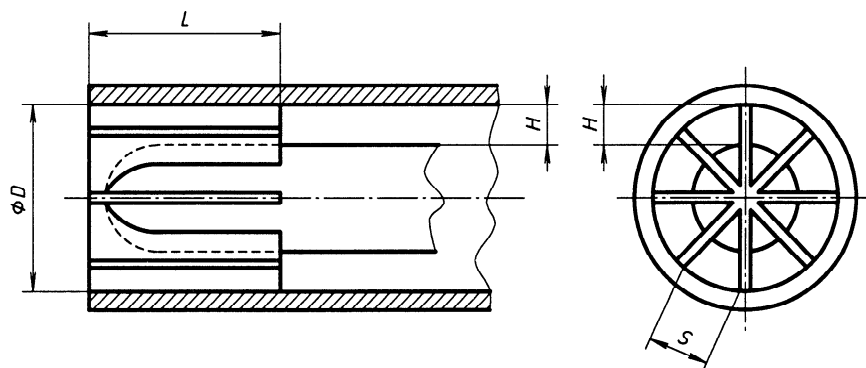

Figure E.5 — Meter dimensions defining similarity for various size meters

UDC 532.575.57:681.121.4

Descriptors: gas flow, pipe flow, flow measurement, flowmeters, turbine meters, specifications, performance evaluation, dimensions, tests, pressure tests, calibration, inspection, marking.

Price based on 15 pages
