**Agricultural irrigation equipment —
Filters for microirrigation —**

**Part 3:
Automatic flushing strainer-type
filters and disc filters**

*Matériel agricole d'irrigation — Filtres pour micro-irrigation —
Partie 3: Filtres à tamis et filtres à disque auto-nettoyants*



Reference number
ISO 9912-3:2013(E)

© ISO 2013



COPYRIGHT PROTECTED DOCUMENT

© ISO 2013

All rights reserved. Unless otherwise specified, no part of this publication may be reproduced or utilized otherwise in any form or by any means, electronic or mechanical, including photocopying, or posting on the internet or an intranet, without prior written permission. Permission can be requested from either ISO at the address below or ISO's member body in the country of the requester.

ISO copyright office
Case postale 56 • CH-1211 Geneva 20
Tel. + 41 22 749 01 11
Fax + 41 22 749 09 47
E-mail copyright@iso.org
Web www.iso.org

Published in Switzerland

Contents

	Page
Foreword	iv
1 Scope	1
2 Normative references	1
3 Terms and definitions	1
4 Marking	2
5 General requirements	2
6 Design and construction requirements	2
6.1 Mandatory requirements	2
6.2 Optional features	4
7 Performance tests	4
7.1 General	4
7.2 Volume of flushing water and duration of flushing	5
7.3 Operation of the flushing control mechanism	5
7.4 Operation of the protective mechanism	6
8 Performance tests after long term simulated use	7
8.1 Multiple flushing cycles procedure	7
8.2 Tests following the multiple flushing cycles	7
9 Information to be supplied by the filter manufacturer	8

Foreword

ISO (the International Organization for Standardization) is a worldwide federation of national standards bodies (ISO member bodies). The work of preparing International Standards is normally carried out through ISO technical committees. Each member body interested in a subject for which a technical committee has been established has the right to be represented on that committee. International organizations, governmental and non-governmental, in liaison with ISO, also take part in the work. ISO collaborates closely with the International Electrotechnical Commission (IEC) on all matters of electrotechnical standardization.

The procedures used to develop this document and those intended for its further maintenance are described in the ISO/IEC Directives, Part 1. In particular the different approval criteria needed for the different types of ISO documents should be noted. This document was drafted in accordance with the editorial rules of the ISO/IEC Directives, Part 2. www.iso.org/directives

Attention is drawn to the possibility that some of the elements of this document may be the subject of patent rights. ISO shall not be held responsible for identifying any or all such patent rights. Details of any patent rights identified during the development of the document will be in the Introduction and/or on the ISO list of patent declarations received. www.iso.org/patents

Any trade name used in this document is information given for the convenience of users and does not constitute an endorsement.

The committee responsible for this document is ISO/TC 23, *Tractors and machinery for agriculture and forestry*, Subcommittee SC 18, *Irrigation and drainage equipment and systems*.

This second edition cancels and replaces the first edition (ISO 9912-3:1992), which has been technically revised.

ISO 9912 consists of the following parts, under the general title *Agricultural irrigation equipment — Filters for microirrigation*:

- *Part 1: Terms, definitions and classification*
- *Part 2: Strainer-type filters and disc filters*
- *Part 3: Automatic flushing strainer-type filters and disc filters*

A fourth part on granulated media filters is planned.

Agricultural irrigation equipment — Filters for microirrigation —

Part 3: Automatic flushing strainer-type filters and disc filters

1 Scope

This part of ISO 9912 specifies general construction requirements and test methods for automatic flushing strainer-type filters and disc filters (hereinafter called “filters”) intended for operation in agricultural irrigation systems.

It does not cover the aspects of filtration ability, efficiency and capacity (like quality of filtered water or time of operation before filter becomes entirely clogged).

NOTE 1 The parameters of filtration ability, efficiency and capacity, their definitions and their test methods are to be included in a separate ISO International Standard or Technical Report. The test methods will be described in that document, using water as defined by the client, to characterize the filter properties during operation with this water, or with water defined by the tester or the client, for comparison between various filters under identical operating conditions.

NOTE 2 ISO 9912-2 covers strainer-type filters and disc filters in general (see [Clause 5](#)).

2 Normative references

The following documents, in whole or in part, are normatively referenced in this document and are indispensable for its application. For dated references, only the edition cited applies. For undated references, the latest edition of the referenced document (including any amendments) applies.

ISO 9912-1, *Agricultural irrigation equipment — Filters for micro-irrigation — Part 1: Terms, definitions and classification*

ISO 9912-2:—¹⁾, *Agricultural irrigation equipment — Filters for microirrigation — Part 2: Strainer-type filters and disc filters*

3 Terms and definitions

For the purposes of this part of ISO 9912, the following terms and definitions apply, together with the relevant definitions in ISO 9912-1 and ISO 9912-2.

3.1

automatic flushing filter

filter in which both the initiation and the termination of discrete flushing cycles are activated automatically

3.2

duration of automatic flushing cycle

period of time during which water and clogging material are flushed out

1) To be published. (Revision of ISO 9912-2:1992)

3.3

flushing control mechanism

mechanism which initiates and terminates the flushing action of a filter

3.4

flushing valve

valve through which flushing water is discharged from a filter

3.5

minimum working pressure

lowest pressure immediately upstream from a filter that is recommended by the manufacturer to ensure proper operation

3.6

minimum filtering pressure

lowest working pressure immediately upstream from a filter, declared by the manufacturer, which ensures the proper functioning of a filter while in the filtering mode

3.7

minimum flushing pressure

lowest working pressure immediately upstream from a filter, declared by the manufacturer, which ensures proper flushing while in the flushing mode

3.8

prefiltration element

part of a filter intended to protect the filter element and cleaning mechanism by collecting especially large particles of the clogging material prior to their reaching the main filter element

3.9

protective mechanism

mechanism that prevents repeated flushings of a filter caused either by mechanical failure in the flushing control mechanism or by some other fault

3.10

volume of flushing water

volume of water flushed from a filter during one flushing cycle

4 Marking

Each filter shall bear all the markings specified in ISO 9912-2:—, Clause 4.

The filter markings shall also include a calibrated permanent scale which shows the individual setting positions, where these exist, for the various options of adjustment of the automatic flushing cycle.

5 General requirements

All the requirements that are included in ISO 9912-2 apply to automatic flushing filters, in addition to the specific requirements and tests that are included in this part of ISO 9912.

6 Design and construction requirements

6.1 Mandatory requirements

Models of typical automatic flushing filters are shown in [Figure 1](#) and [Figure 2](#).

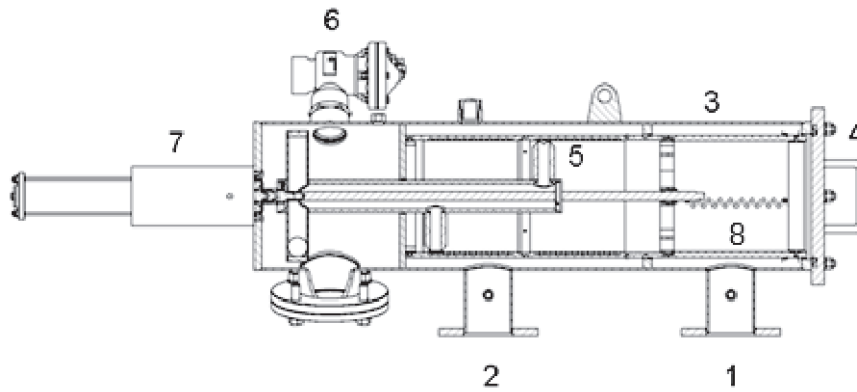

Key

- | | |
|------------------------|------------------------------|
| 1 inlet | 5 filter element |
| 2 outlet | 6 flushing valve |
| 3 filter housing | 7 flushing control mechanism |
| 4 filter housing cover | 8 prefilter |

Figure 1 — Typical structure of an automatic flushing strainer-type filter

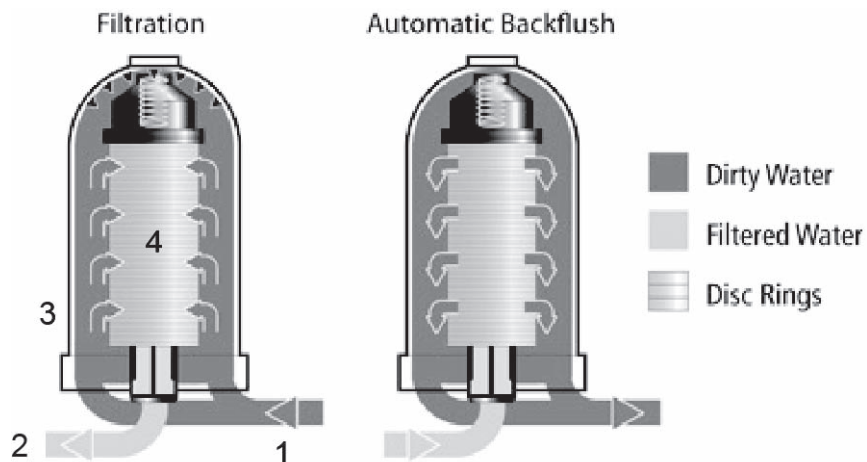

Key

- | |
|------------------|
| 1 inlet |
| 2 outlet |
| 3 filter housing |
| 4 disc elements |

Figure 2 — Typical structure of an automatic flushing disc filter

The construction of an automatic self-cleaning filter shall comply with the following requirements.

- a) The flushing control system shall be a part of the filter assembly and shall be supplied by the manufacturer together with the filter, or shall be a part produced by the filter manufacturer and supplied according to special demand of the customer. Alternatively, the flushing control system may be manufactured by a third party, provided that it is approved by the filter manufacturer and is included in the information supplied by the manufacturer (see [Clause 9](#)).

- b) The construction of the filter shall allow manual actuation of automatic flushing in the event of failure of the automatic flushing control mechanism.
- c) The flushing control mechanism shall allow manual flushing at any time, irrespective of the conditions that apply to automatic flushing.
- d) The construction of the filter housing shall permit dismantling for maintenance (or for cleaning, if the filter is also designed for manual cleaning).
- e) The coordination of the flushing operation and the opening of the flushing valve shall prevent water flowing out of the flushing valve unless the filter is being cleaned. During flushing, it shall be open for at least one full flushing operation.
- f) The initiation and termination of flushing may be activated by pressure differential, by duration of filtration, by volume of water filtered, by another physical quantity or by a combination of these.
- g) When a prefiltration element exists, the maximum pressure drop across it shall be less than the safe maximum pressure drop of the filter assembly.

6.2 Optional features

In addition, the following construction features are recommended.

- a) The filter may be fitted with a device that enables adjustment of the preset value of the flushing control mechanism for initiation of the flushing cycle, for controlling the duration and termination of the flushing cycle.
- b) The filter may be equipped with a protective mechanism that prevents repeated flushings (see [3.9](#)).
- c) All hydraulically operated accessories of the filter should be operated using filtered water, with the exception of the inlet pressure signal which may come from non-filtered water.
- d) The design of a prefiltration element, its filtering area, the size of water passages and their shape should be appropriate for the water quality for which the filter is intended.

NOTE 1 The prefiltration element is an optional component.

- e) The prefiltration element should be an integral part of the filter while being tested according to [Clauses 7](#) and [8](#). (This element is not intended to be tested separately.)

NOTE 2 The prefiltration element is not automatically flushed.

7 Performance tests

7.1 General

The tests and the requirements given in [Clauses 7](#) and [8](#) apply to filters whose design or manner of operation are in accordance with the concept inferred by the test process described in the applicable clause.

The concepts of flushing cycle and flushing duration may not apply to all filters within the scope of this part of ISO 9912 (for example: automatic continuous-flushing filters).

In such cases, the test procedure shall be adapted to the specific filter design and the declaration in the manufacturer's literature. However, it is important to ensure that the volume of flushing water shall not exceed that declared by the manufacturer by more than 7 %.

A filter that does not contain an integral control system shall be tested together with a control system indicated in the manufacturer's literature, as a combined system. In this case, the results of the test will apply only to the combination of the tested filter and the specific control system.

7.2 Volume of flushing water and duration of flushing

7.2.1 Test at specific operating pressures

Connect the filter as described in the manufacturer's instructions to a test assembly, simulating field installation. Ensure that the test assembly is capable of supplying at least twice the maximum flushing volume at the nominal pressure, as declared by the manufacturer.

Attach a collection vessel to the flushing opening of the filter for collecting the flush water. Set the pressure at the filter inlet to the *minimum flushing pressure* and initiate a flushing cycle manually.

Measure the volume of the collected flushing water and the time from the moment the flush valve begins to open to the time it closes.

Repeat the test at the *nominal pressure*.

The following requirements shall be met:

- a) the volume of water measured in each of the tests shall not exceed the volume of flushing water declared by the manufacturer by more than 7 %;
- b) the duration of flushing measured shall not deviate from the flushing duration declared by the manufacturer by more than ± 15 %.

7.2.2 Test at the minimum flow rate

Connect the filter as described in [7.2.1](#). Ensure that the test assembly is capable of supplying at least the maximum flow rate recommended at a pressure differential equal to the safe maximum pressure drop.

Attach a collection vessel to the flushing outlet of the filter for collecting the flush water. Operate the filter at a flow rate equal to the *minimum recommended flow rate*, with the pressure at the filter set to the critical pressure drop before failure. Manually activate the flushing mechanism twice.

At each activation measure the volume of flush water and the time from the moment the flush valve begins to open to the time it closes.

The following requirements shall be met:

- a) the flushing mechanism shall operate satisfactorily (the flushing process is completed);
- b) the volume of water measured in each of the tests shall not exceed the volume of flushing water declared by the manufacturer by more than 7 %;
- c) the duration of flushing measured shall not deviate from the flushing duration declared by the manufacturer by more than ± 15 %.

7.3 Operation of the flushing control mechanism

7.3.1 Mechanism activated by pressure differential sensor

Disconnect the "low" pressure connection of the pressure differential sensor and connect it to an external pressure source. Leave the "high" pressure connection as connected for regular filter operation.

Apply a pressure equal to the minimum filtering pressure at the filter inlet and at the external pressure source. Gradually reduce the pressure at the external pressure source until the flushing operation is performed.

Repeat the test once with a filter inlet pressure at midrange between the minimum filtering pressure and the nominal pressure, and once more with a filter inlet pressure equal to the nominal pressure.

The pressure differential (the filter inlet pressure minus the external source pressure) that causes flushing shall not deviate from the pressure differential declared by the manufacturer by more than ± 10 %.

7.3.2 Mechanism activated by duration of operation

Perform the test three times, each time presetting the flushing control mechanism to a different time interval – short, long and intermediate – within the range of adjustment declared by the manufacturer.

Operate the filter with an inlet pressure equal to the minimum filtering pressure. Measure the time interval between one activation and the next one.

Repeat the tests with a filter inlet pressure equal to the nominal pressure.

The time interval between the two activations shall not deviate from the preset time interval by more than $\pm 5\%$.

7.3.3 Mechanism activated by volume of filtered water

Perform the test twice, each time presetting the flushing control mechanism to a different volume of water within the range specified by the manufacturer. Select one volume from the lower 20 % of the range and the second volume from the upper 20 % of it.

Operate the filter and measure the volume of water flowing through the filter up to activation of the automatic flushing control mechanism.

The measured volume of water flowing through the filter shall not deviate from the preset quantity of water by more than $\pm 10\%$.

7.3.4 Mechanism activated by another physical quantity

Connect the filter to a water source and make all the adjustments necessary in accordance with the manufacturer's instructions.

Maintain the pressure at the inlet to the filter at the minimum filtering pressure.

If the flushing control mechanism is adjustable conduct the test three times, with the flushing control mechanism preset differently each time, to the lowest, the highest and the mid-range setting, respectively. Otherwise, conduct the test only once.

Operate the filter according to the manufacturer's instructions until three flushing cycles have been completed.

Measure the value of the activating physical quantity at the initiation of each flushing cycle.

Repeat the entire process with the pressure at the inlet of the filter readjusted to the nominal pressure.

The following requirements shall be met:

- a) the flushing cycle shall be initiated and shall proceed as prescribed by the manufacturer;
- b) the value of the activating physical quantity at the initiation of any flushing cycle shall not deviate by more than $\pm 10\%$ from the preset value for an adjustable mechanism, or by more than $\pm 10\%$ of the value declared by the manufacturer for a non-adjustable mechanism.

7.4 Operation of the protective mechanism

In filters equipped with a protective mechanism to prevent repeated flushing, test the mechanism as described below.

Operate the filter at an inlet pressure equal to the minimum filtering pressure. Perform three consecutive flushings manually.

The filter shall flush satisfactorily.

Continue to operate the flushing control mechanism manually several times until the protective mechanism stops the flushing cycle, or create by artificial means the conditions declared by the manufacturer which will activate the protective mechanism.

The number of flushings or (depending on the type of control mechanism) the time that elapsed, until activation of the protective mechanism, shall not deviate by more than $\pm 10\%$ from the manufacturer's declaration.

8 Performance tests after long term simulated use

The following tests are designed to evaluate the performance of a filter after 10 000 flushing cycles under the simulated-use conditions in [8.1](#).

8.1 Multiple flushing cycles procedure

Operate the filter using clean water (as defined in ISO 9912-2:—, 6.4) or a similar type of water (chemically and physically).

Initiate each flushing cycle by appropriate means, to be determined and described by the laboratory.

NOTE Since the automatic flushing control capability will not be usable in these tests, performance of the flushing control mechanism is not taken into account.

Activate each flushing cycle 10 000 times using the following procedure.

- a) Establish the pressure at the filter inlet and maintain it for at least 10 s at the nominal pressure and cause water to flow through the filter at a flow rate approximately equal to the flushing flow rate at the nominal pressure plus 20 %.
- b) While maintaining the pressure at the filter inlet at not less than the minimum filtering pressure ([3.6](#)), allow the flushing cycle to terminate without external intervention.

8.2 Tests following the multiple flushing cycles

After completion of the 10 000 cycles, carry out the following tests.

8.2.1 Performance tests

Carry out the following performance tests:

- a) resistance of filter to internal hydrostatic pressure (ISO 9912-2:—, 6.2);
- b) volume of flushing water and duration of flushing ([7.2](#)).

The filter shall meet the requirements specified in each of these tests.

8.2.2 Visual examination

Dismantle the filter and examine its internal parts for excessive wear or damage. The parts shall show no damages, such as damage to the filter housing, to moving parts or to the filtering elements, nor any cracks or fractures.

Damage to moving parts or to the seals, which do not impair the functioning of the filter, shall not be considered as a failure in this test.

9 Information to be supplied by the filter manufacturer

In addition to the information specified in ISO 9912-2:—, Clause 7, the manufacturer shall supply the following information, as applicable:

- a) minimum working pressure;
- b) minimum filtering pressure;
- c) minimum flushing pressure;
- d) maximum pressure differential allowed to initiate flushing;
- e) range of pressure differential to initiate flushing;
- f) maximum flow rate;
- g) minimum flow rate;
- h) duration of flushing;
- i) volume of flush water at minimum flushing pressure and nominal pressure;
- j) range of adjustment for flushing control setting according to time, volume, etc.;
- k) < in filters equipped with protective mechanism > number of repeat flushings until flushing stops, in the event of a failure;
- l) minimum size, maximum length and maximum elevation of pipe for disposal of flush water, relative to filter position;
- m) flushing control mechanisms approved by the manufacturer for use with this filter.

.....

ICS 65.060.35

Price based on 8 pages