

INTERNATIONAL STANDARD

ISO
9897

First edition
1997-12-15

Freight containers — Container equipment data exchange (CEDEX) — General communication codes

*Conteneurs pour le transport de marchandises — Échange de données sur
les équipements de conteneurs (CEDEX) — Codes des communications
générales*



Reference number
ISO 9897:1997(E)

Contents

Page

1	Scope.....	1
2	Normative references	1
3	Principle	1
4	Data elements and codes.....	2

Annexes

A	Codes — Message types	4
B	Codes — Structural condition, repair condition, outside coating, inside coating, full/empty indicator.....	5
C	Codes — Damage location.....	6
D	Codes — Damage types	14
E	Codes — Material types	17
F	Codes — Repair type	19
G	Codes — Measure unit specifier; repair size dimension and work scales.....	22
H	Codes — Responsibility	23
J	Codes — Party identification and location.....	24
K	Codes — Components of container	25
L	Codes — Components of chassis	69
M	Alphabetical list of CEDEX codes.....	78

© ISO 1997

All rights reserved. Unless otherwise specified, no part of this publication may be reproduced or utilized in any form or by any means, electronic or mechanical, including photocopying and microfilm, without permission in writing from the publisher.

International Organization for Standardization
Case postale 56 • CH-1211 Genève 20 • Switzerland
Internet central@iso.ch
X.400 c=ch; a=400net; p=iso; o=isocs; s=central

Printed in Switzerland

Foreword

ISO (the International Organization for Standardization) is a worldwide federation of national standards bodies (ISO member bodies). The work of preparing International Standards is normally carried out through ISO technical committees. Each member body interested in a subject for which a technical committee has been established has the right to be represented on that committee. International organizations, governmental and non-governmental, in liaison with ISO, also take part in the work. ISO collaborates closely with the International Electrotechnical Commission (IEC) on all matters of electrotechnical standardization.

Draft International Standards adopted by the technical committees are circulated to the member bodies for voting. Publication as an International Standard requires approval by at least 75 % of the member bodies casting a vote.

International Standard ISO 9897 was prepared by Technical Committee ISO/TC 104, *Freight containers*, Subcommittee SC 4, *Identification and communication*.

This first edition of ISO 9897 cancels and replaces the first editions of ISO 9897-1:1990 and ISO 9897-3:1990, which have been technically revised.

Annexes A to H and K, L form an integral part of this International Standard.

Annexes J and M are for information only.

Freight containers — Container equipment data exchange (CEDEX) — General communication codes

1 Scope

This International Standard specifies general communication codes for container equipment data exchange (CEDEX).

It is intended for business entities for use in communications relating to freight container transactions.

2 Normative references

The following standards contain provisions which, through reference in this text, constitute provisions of this International Standard. At the time of publication, the editions indicated were valid. All standards are subject to revision, and parties to agreements based on this International Standard are encouraged to investigate the possibility of applying the most recent editions of the standards indicated below. Members of IEC and ISO maintain registers of currently valid International Standards.

ISO 3166:1993, *Codes for the representation of names of countries*.

ISO 6346:1995, *Freight containers — Coding, identification and marking*.

UN/EDIFACT *Draft Directory and Standard Directory*.

3 Principle

In ISO 9897, codes are assigned to pieces of information, called "data elements", which are commonly used in transactions relating to freight containers. These data elements are named and defined, and each element is assigned a CEDEX alphabetical or alphanumeric code. Separate code lists for each type of information (damage, component, repair, location, etc.) are maintained. A code may be reused in several different code lists, but a code is never used for more than one data element within a single code list.

The data element may be phrased about material of construction of a container. For example, CEDEX code "LS" in material type code list (Annex E) stands for "wood, soft laminated plank". A code may define the component of the container that is damaged, its location, or its operating defect, depending on which data element is being defined. A selection is made from the appropriate code list to indicate which component, location, or defect, respectively, is chosen. An example of the latter is CEDEX code "MF", drawn from the damage type code list (Annex D), which stands for "motor failure". Other coded data elements indicate essential physical characteristics of the container and information pertinent to the use and management of the container, such as names and addresses of owners.

It can be seen from these examples that the text of a message can be substantially reduced in length by using the CEDEX codes instead of plain language. Use of the CEDEX codes results in messages much reduced in length, transmission time and communication cost, yet conveying information as complete as a much longer plain-language message.

Through proper programming of a computer, a CEDEX-encoded message can be printed out in plain language for the benefit of the communicators, if so desired, or it can be left in its encoded form. The personnel using the code routinely will develop the skill of being able to read messages in coded form; in fact, experience using the code has borne out this assertion. Also, many operators will not require use of all CEDEX codes assigned in ISO 9897, but only a portion of them due to the limited variety of containers and chassis in their domain.

4 Data elements and codes

4.1 Data elements

Data elements and corresponding code sets required to describe equipment components, their condition, repair methods, etc., are included in the appropriate annex shown in table 1.

4.2 Code assignments

4.2.1 CEDEX codes

All code assignments of CEDEX shall be taken as obligatory. That is, an operator shall not pick and choose alternative codes unilaterally, nor depart from the established protocol, nor introduce new codes without having registered the codes in accordance with 4.3.

However, two trading partners may agree mutually to use alternative codes if the necessary codes are not included in this International Standard. It is strongly recommended that such codes be registered in accordance with 4.3 as soon as possible after introduction.

4.2.2 EDIFACT codes

Code assignments according to Annex A shall taken as obligatory. That is, for electronic data interchange transmission, an operator shall not pick and choose alternative codes unilaterally and shall not use the message types and codes contained in Annex A of ISO 9897-1:1990 (i.e the first edition of this International Standard).

Note - Annex J is at the moment merely informative; it describes the manner in which a directory of users will eventually be developed. Until the directory is issued, annex J is not a mandatory requirement of this International Standard.

Table 1 - Data elements and code sets

Data elements	Code set see annex
Message type	A
Full/empty indicator (container)	B
Structural condition (container)	B
Repair condition (container)	B
Outside coating (container)	B
Inside coating (container)	B
Damage location	C
Damage type	D
Material type	E
Repair type	F
Measure unit specifier	G
Repair size dimension	G
Work scale (standard time factor)	G
Responsibility (for repair action)	H
Party identification and location	J
Component for container	K
Component for chassis	L

4.3 Updating data elements

The *International Intermodal Repairers (IIR)* has been nominated to act as the Registration Authority for the data elements:

International Intermodal Repairers (IIR)
c/o CEDEX Services International
450 Sansome St.
San Francisco, CA 94111
U S A

Telefax: +1 415 398 3610
Internet: <http://www.intermodalrepairers.com>

Additional data elements will be added to table 1 at the request of international organizations, ISO/TC 104 member bodies, and approval of TC 104/SC 4. The actual process of registration will be performed by the TC 104/SC 4 Secretariat in consultation with the experts of TC 104 /SC 4/WG 3.

Each additional data element will be allocated an alphabetic or alphanumeric code, not at present used within the same code list covering a type of data.

Annex A (normative)

Codes — Message types

(see notes below and 4.2.2)

Numerical code	Name	Description	EDIFACT code¹⁾²⁾
01050	Damage/repair estimate	Description of damages and repair methods; authorization for repair work to proceed	DESTIM

NOTES:

1. To be used for electronic data interchange transmissions. See appropriate message descriptions published by UN/EDIFACT to determine messages to which the codes in this standard may apply. Further message types and equivalent EDIFACT codes will be added as released by EDIFACT.
2. EDIFACT codes, message standards (including the relevant message type codes) are controlled by UN/EDIFACT (Electronic Data Interchange for Administration, Commerce, and Transport), a subsidiary organization to UN/ECE/WP.4. ISO has assented to this arrangement via a memorandum of understanding between ISO and UN/ECE.

Annex B (normative)

Codes — Structural condition, repair condition, outside coating, inside coating; full/empty indicator

(see 4.1 and 4.2)

Numerical code	Name	Description	CEDEX code
B.1 Structural condition, repair condition, outside coating, inside coating			
01110	Bad	Inferior quality or state of structural parts, workmanship, surface treatment, etc.	B
01120	Poor	Poor quality or state of structural parts, workmanship, surface treatment, etc.	P
01130	Medium	Average or acceptable quality or state of structural parts, workmanship, surface treatment, etc.	M
01140	Good	Good quality or state of structural parts, workmanship, surface treatment, etc.	G
01150	Excellent	Excellent quality or state of structural parts, workmanship, surface treatment, etc.	X
B.2 Full/empty indicator			
01160	Empty	Empty condition of equipment	E
01170	Full	Loaded condition of equipment	F

Annex C (normative)

Codes — Damage location

(see 4.1 and 4.2)

C.1 Location coding convention

The location coding convention consists of three parts:

- a) For dry cargo, open top, thermal, tanks, and other container types:
 - A 1200 mm x 1200 mm (4 ft x 4 ft) numerical square system is used to identify damage to any face of a 20 ft or 40 ft container.
 - A 600 mm x 600 mm (2 ft x 2 ft) numerical square system is used to identify damage to any face of a 10 ft container.
 - A 900 mm x 900 mm (3 ft x 3 ft) numerical square system is used to identify damage to any face of a 30 ft container.
- b) For container ancillary equipment, which are an integral part of the container, such as reefer machinery, tank specific components, diesel generator set:
 - The location field is used to indicate the functional group to which a component belongs.
- c) For chassis:
 - As indicated in C.1.3.

C.2 All container bodies, refrigeration units, and generator sets (except chassis)

The container location coding convention locates damages within an area as large as a complete face of the container or as small as a nominal 1200 mm x 1200 mm (4 ft x 4 ft) square, or even less for the main components located on its edges (rails, corner posts).

The location code shall consist of four characters depending upon the area to be described. It identifies the smallest area containing the entire vertical and horizontal length of the damage.

C.2.1 First character

The first character shall be selected to identify the appropriate face of the container (if applied to a rectilinear closed container) or to the type of unit (if applied to a generator set, refrigeration unit, or tank container). For examples of use of codes for units other than closed containers or platforms, see C.1.2.

bottom (floor)	B
chassis	C
door end (rear)	D
container exterior	E
front end	F
generator set	G
container interior	I
left side	L
refrigeration unit	M
right side	R
tank container	A
top/roof	T
understructure	U
unspecified component	N
whole container or unit	X

C.2.2 Second character

It shall be selected to identify the appropriate part of the container face where the damage is contained, when applied to a closed container. The vertical faces of the container are divided into top and bottom halves and upper and lower main components. The horizontal faces of the container (roof or top and floor or bottom and understructure) are divided into right and left halves when viewed from the door end.

The relevant codes for CLOSED CONTAINERS are:

both halves (i.e. top and bottom, or left and right or centre)	X
bottom half	B
higher portion (upper)	H
left half	L
lower portion (ground)	G
right half	R
top half	T

For other types of units, such as refrigeration units and generator sets, the second character designates the major assembly of the unit in which the damage is found. See C.1.2 for examples of how these codes are used. (Codes for chassis are shown in C.1.3.)

The relevant codes for REFRIGERATION UNITS are:

compressor	Q
condenser	K
electrical	E
evaporator	V
frame	F
miscellaneous	Z
pipng	P
regulation/control	C
unspecified assembly	N
whole unit	X

The relevant codes for GENERATOR SETS are:

alternator	L
electrical	E
engine (diesel)	D
frame	F
fuel system	U
miscellaneous	Z
oil system	O
unspecified assembly	N
water system	W
whole unit	X

The relevant codes for TANK CONTAINERS are:

access	A
frame	F
heating	H
insulation	I
loading/unloading	L
manhole	M
marking	D
miscellaneous	Z
pressure vessel	P
safety components	S
spill box	B
unspecified assembly	N
whole unit	X

C.2.3 Third and fourth characters

They shall be selected to identify the section of the container part in which the damage is contained.

On all containers the front and door ends are divided into vertical sections numbered as follows when viewed from the door end from left to right:

- 1 for the left-hand side corner post
- 2 for the left half
- 3 for the right half
- 4 for the right-hand side corner post.

On all containers the right and left sides, the roof, the floor and the understructure, are divided into equal sections:

- for 10 ft and 20 ft containers, five sections numbered 1 to 5
- for 30 ft and 40 ft containers, ten sections numbered 1 to 0 (1, 2, 3, ..., 9, 0).

When the damage covers one section only, the third character indicates the appropriate section number and the fourth character shall be N [see figure C.1a)].

When the damage covers several adjacent sections the first and last section numbers are used [see figure C.1b)].

When the damage covers several non-adjacent sections or if damage repair details are not the same, then separate line items shall be used [see figure C.1c)].

When the damage covers the entire length of the container face, the third and fourth characters shall each be X [see figure C.1d)].

The third and fourth characters of units other than closed containers, chassis and platforms, such as refrigeration units, generator sets, and tank containers, shall be "NN". No further identification of the location of components on these units is required.

C.2.4 General location coding

When the damage/action covers *several faces of the inside* of the container such as steam cleaning, inside refurbishment, refixing or sealing of panels, then the code IXXX shall be used.

When the damage/action covers *several faces of the outside* of the container such as outside refurbishment, refixing or sealing of panels, removing of cargo stickers, then the code EXXX shall be used.

When the damage/action covers *several inside and outside faces* of the container such as examinations, handling/transport, complete refurbishing, then the code XXXX shall be used.

C.2.5 Examples of location coding for containers

Examples of location coding of components of typical containers are shown below. A diagram showing the components is shown in Figure C.1.

NOTE - LHS = left-hand side;

RHS = right-hand side;

* = specific sequential number of component will be defined in separate free-text field.

Reference in Figure C.1	Location code	Component code	Description
a	LT5N	PAA	Side panel, LHS, upper half, within the 5th 1200 mm (4 ft) section from rear
b	RT24	PAA	Side panel, RHS, upper half, extending through 2 nd to 4 th sections from rear
c	RB2N	PAA	Side panel, RHS, lower half, within the second section from the door
c	RB4N	PAA	Side panel, RHS, lower half, within the fourth section from rear
d	TXXX	PAA	Roof panel, both sides, extending through all sections
e	UX1N	CMA	Cross-member, both sides, within first section from door
f	UR12	CMA	Several cross-members, RHS, extending through first two sections*
g	TX12	RBO	Roof bows, both sides, extending through first two sections*
h	TR1N	RBH	Roof bow holder, RHS, within first section (bow holder number will be defined in separate free-text field)
i	UL8N	CMA	Outrigger, LHS, within the eighth section from door (40 ft) (outrigger number will be defined in separate free-text field)
j	UX3N	FLW	Web (side) of forklift pocket, both sides, within third section from door (pocket number will be defined in separate free-text field)
k	UR4N	FLS	Forklift pocket strap, RHS, within fourth section from door (pocket number will be defined in separate free-text field)
l	RX1N	SBO	Side post, RHS, both halves, within the first section from door (post number will be defined in separate free-text field)
m	UX15	RLA	Centre spacer rail, extending through sections 1-5 from door
n	UR80	RLA	Tunnel rail, extending through sections 8-10 from door
o	DX2N	LBA	Locking bar, LH door, both halves (locking bar number will be defined in separate free-text field)

NOTE- Specific sequential number of component will be defined in separate free-text field as follows:

- Roof bows, cross-members, outriggers and forklift pocket sides are to be numbered from rear (door) end to front
- Locking bars are to be numbered from left to right.

C.3 Ancillary equipment

The specific components of ancillary equipment which are an integral part of a container such as refrigeration machinery, diesel generator, tank fittings are identified

- firstly, by the two alpha characters selected to identify the major functional group to which the component belongs: they are the first and second characters of the location code;
- secondly, by the code NN: it forms the third and fourth characters of the location code.

EXAMPLES

MQNN	Reefer machinery (compressor)
APNN	Tank container (pressure vessel)
GDNN	Generator set (engine).

Components that occur more than once in an ancillary equipment or which are common or similar to other components are given the same component code but are differentiated by functional group code.

EXAMPLES

Location field	Component field	Description
MKNN	MAS	Refrigeration machinery - Condenser fan motor
MVNN	MAS	Refrigeration machinery - Evaporator fan motor
MPNN	VSA	Refrigeration machinery - Suction solenoid valve
ASNN	YTR	Tank - Safety relief valve

C.3.1 Chassis

C.3.2 First character

The first character of the location code for all chassis is always C.

C.3.3 Second character

The second character defines the major assembly of the chassis. The relevant codes are:

axle (full width)	A
bumper (rear end) area	B
frame (main)	F
frame (extension)	Y
kingpin/grid/upper coupler	K
landing gear	G
left wheel(s)	L
miscellaneous	Z
right wheel(s)	R
subframe/suspension	U
unspecified assembly	N
whole unit	X

C.3.4 Third and fourth characters

On all chassis, the third and fourth characters indicate the section of the relevant assembly (defined by the second location code character) affected. Acceptable characters are shown in table C.1 below:

Table C.1

Second character: Assembly (code)	Third character	Fourth character
Axle-full width (A)	N: Not applicable X: All wheels on axle	C: Centre axle (triale unit) F: Front axle N: Not specified R: Rear axle X: All axles
Bumper-rear end (B)	L: Left half N: Not specified R: Right half X: Both halves	N: Not applicable
Frame (main) (F)	Rearmost damaged section (identify left half, right half or both halves as applicable): 1: Aft section, left half (aft or forwardmost point on running gear or slider range if applicable) 2: Central section, left half (between landing gear and aft section) 3: Forward section, left half (forward of landing gear) 4: Aft section, right half 5: Central section, right half 6: Forward section, right half 7: Aft section, both halves 8: Central section, both halves 9: Forward section, both halves N: Not specified X: Entire frame	Forwardmost damaged section: Same codes as third character, except N also used when damage is limited to a single section
Frame extension (Y)	L: Left half N: Not specified R: Right half X: Both halves	F: Front half N: Not specified R: Rear half X: Both halves
Kingpin/grid/upper coupler (K)	L: Left half N: Not specified R: Right half X: Both halves	F: Front half N: Not specified R: Rear half X: Both halves
Landing gear (G)	L: Left half N: Not specified R: Right half X: Both halves	N: Not applicable
Left wheel(s) (L)	I: Inside wheel N: Not applicable O: Outside wheel X: Both inside and outside wheels	C: Centre axle (triale unit) F: Front axle N: Not specified R: Rear axle X: All axles
Miscellaneous (Z)	N: Not applicable	N: Not applicable
Right wheel(s) (R)	I: Inside wheel N: Not applicable O: Outside wheel X: Both inside and outside wheels	C: Centre axle (triale unit) F: Front axle N: Not specified R: Rear axle X: All axles
Subframe/suspension (U)	L: Left half N: Not specified R: Right half X: Both halves	F: Front half N: Not specified R: Rear half X: Both halves
Unspecified assembly (N)	N: Not applicable X: Entire assembly	N: Not applicable X: Entire assembly
Whole unit (X)	X: Entire assembly	X: Entire assembly

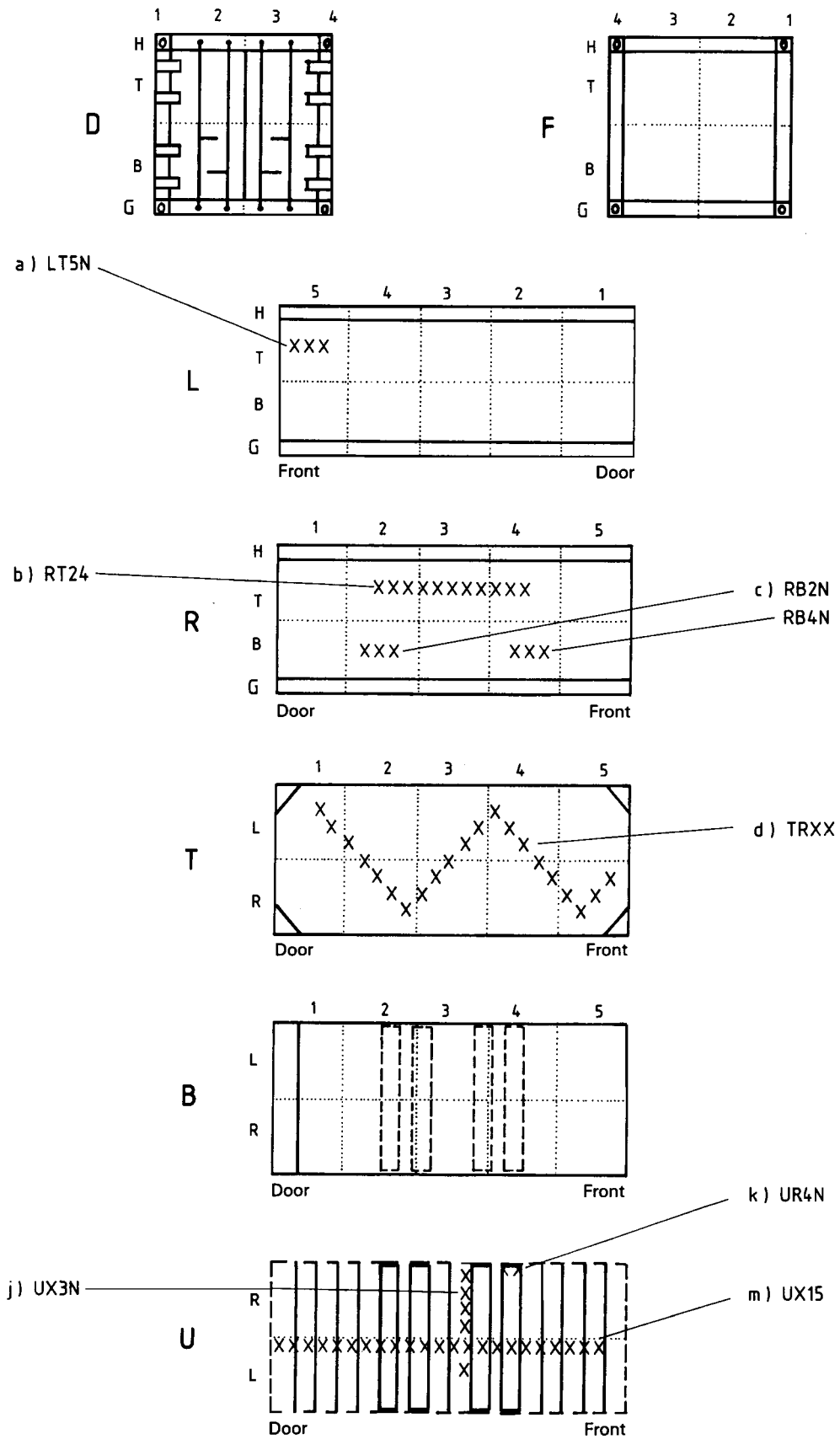

Figure C.1 — Examples of location coding for containers

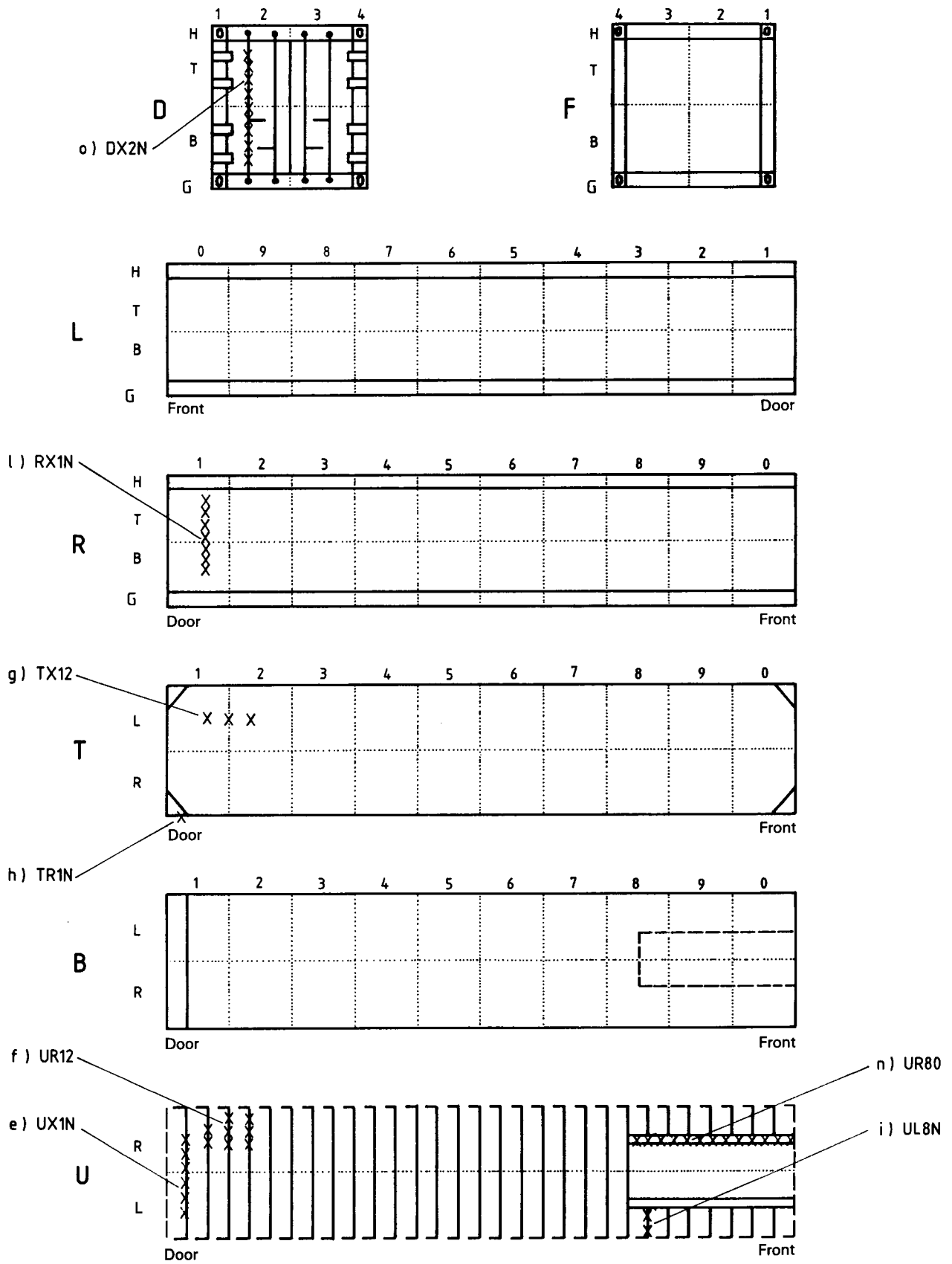

Figure C.1 (concluded)

Annex D (normative)

Codes — Damage types

(see 4.1 and 4.2)

Numerical code	Name	Description	CEDEX code
04010	Bald	Tyre is bald or worn to less than legal tread depth remaining	WB
04020	Bent	Component is damaged by being bent	BT
04030	Bowed	Component is damaged by being bowed. Usually damage is gradual over the length of the component	BW
04040	Blocked	Drain, tube, outlet, etc. is blocked	BK
04050	Blowout	Tyre is unusable due to a blowout	BL
04060	Broken/split	Component is damaged by being broken or split	BR
04065	Bulged	Weakened wall permitting formation of a bulge due to internal pressure	BU
04069	Burned	Component whose surface is damaged by burns	BN
04070	Burned out	Electrical component is burned out	BO
04080	Casing/tread separation	Casing or tread has separated from the carcass of the tyre	TS
04090	Compression line	Series of dents in a straight line that decreases the strength of a component when it is placed in compression	CL
04100	Contaminated	Equipment is rendered unsuitable for cargo because of contamination by chemicals or other cargo products, or by infestation	CT
04110	Corroded/rusty	Component is corroded or rusty	CO
04115	Cracked	Crack apparent either in surface or through part or all of component profile	CK
04117	Cracked weld	Welding seam is damaged by being cracked	CW
04120	Cut	Component is damaged by being cut	CU
04130	Curbing	Tyre is rendered unusable by being damaged in the shoulder area by running up on the curb	CB
04140	Debris/dunnage	Equipment is unusable due to cargo residue or dunnage left inside	DB
04150	Delaminated	Component, usually of wood, is damaged due to separation of laminations	DL
04160	Dent	Component is damaged by being dented	DT
04165	Dirty	Unclean condition that may affect utility of container	DY
04170	Flat/puncture	Tyre is deflated due to being punctured	FP
04180	Flat spots	Tyre has spots or areas where tread is worn below legal limits for tread depth remaining	FS

Numerical code	Name	Description	CEDEX code
04190	Frozen	Component is inoperable by being frozen or corroded	FZ
04200	Gouged	Component is damaged by being gouged	GD
04210	GRP surface crack	GRP panel is cracked through the glass and gelcoat only	GO
04220	GRP surface and plywood crack	GRP panel is cracked through the glass, gelcoat and plywood	GP
04230	Holed	Component is damaged by being holed	HO
04240	Improper repair	A repair that does not conform to owner's requirements or industry standards	IR
04250	Leak	Equipment or component leaks	LK
04260	Loose	Component is loose	LO
04270	Low fluid level	Component or system has less than required amount of fluid	LF
04280	Markings/labels	Labels, marks, logos, and graffiti, etc., not required by owner	ML
04290	Motor failure	Motor will not function	MF
04300	Misaligned	Component, usually chassis tandem, is misaligned	MA
04310	Mismatched	Two adjacent tyres have different diameters and are, therefore, not acceptable as matched pair	MM
04320	Missing/lost	Component is missing or lost	MS
04330	Nails	Equipment is rendered unsuitable for cargo due to nails, usually in flooring	NL
04340	Not within ISO dimensions	Equipment is not usable because it is no longer within the ISO dimensional envelope	NI
04350	Not to TIR requirements	Equipment or component no longer complies with TIR regulations	NT
04355	Not applicable	A condition for which no specific damage type applies	ZZ
04360	Not as required by owner	Equipment or component no longer complies with owner's requirements	NO
04365	Not as required by user	Equipment or component no longer complies with user's requirements	NV
04370	Odour	Equipment is rendered unsuitable for cargo because of odour	OR
04380	Oil saturated	Component, usually flooring, is damaged by being heavily contaminated with oil	OL
04390	Oil stains	Component, usually flooring, is damaged by being spotted with oil	OS
04400	Other unacceptable repairs	Any repair deemed unacceptable by the owner or for reasons not specifically covered	OU
04410	Out-of-date	Renewal of a periodic inspection, test or document is overdue	OD

Numerical code	Name	Description	CEDEX code
04420	Over-inflated	Tyre is damaged by being run while over-inflated	OI
04430	Under-inflated	Tyre is damaged by being run while under-inflated	UI
04440	Pin holes	Component is damaged with minute holes	PH
04445	Rotted	Component integrity compromised by rot	RO
04450	Run flat	Tyre is damaged by being run with very little or no inflation	RF
04455	Scratched/abraded moving part	Moving part (bearing, piston, etc.) scored, scratched, or abraded by friction	SA
04460	Separated	Brake lining has separated from the brake shoe	SP
04470	Short/open circuit	Electrical system is inoperable due to a short or open circuit	SH
04480	Shrunk	Component, usually tarpaulin, cover, tilt, or flooring is damaged by shrinkage	SR
04490	Stretched	Component, usually tarpaulin, cover, or tilt is damaged by stretching	SD
04500	Switched	Tyre is not original and is not comparable to the other tyres on the chassis	SW
04510	Uneven tread	Adjacent tyres have different tread depth remaining	TU
04520	Paint failure	Component suffers from a breakdown of the paint system	PF
04540	Warped	Component is damaged by being warped	WA
04550	Weathered	Tyre is rendered unusable due to long exposure to weather	WV
04560	Wear and tear	The unavoidable deterioration of a component during usage under proper operating conditions	WT
04570	Worn	Component is rendered unusable by being worn. For a tyre, worn to below legal tread depth remaining	WN
04580	Wrong material	Previous repair or replacement was carried out using the wrong material	WM

Annex E (normative)

Codes — Material types

(see 4.1 and 4.2)

Numerical code	Name	Description	CEDEX code
05000	Material unspecified	Material is not specified	MU
05100	Steel unspecified	Material is steel of no specific type	SU
05110	Steel, carbon	Material is of carbon steel	ST
05120	Steel, corten	Material is of corten steel	SK
05130	Steel muffler	Material is muffler grade steel (semi-corrosion resistant)	SM
05140	Steel, stainless	Material is stainless steel (corrosion resistant)	SS
05150	Steel, galvanized	Material is galvanized steel	SG
05200	Aluminium unspecified	Material is aluminium of no specific type	AU
05210	Aluminium pre-painted	Material is of pre-painted aluminium	AP
05300	Wood	Material is of wood of no specific type	WU
05310	Wood, hard plank	Material is of hardwood plank	WH
05320	Wood, soft plank	Material is of softwood plank	WS
05330	Wood, laminated plank	Material is vertically laminated plank of no specific wood type	LU
05340	Wood, hard laminated plank	Material is vertically laminated hardwood plank	LH
05350	Wood, soft laminated plank	Material is vertically laminated softwood plank	LS
05360	Plywood	Plywood, unspecified type	PP
05370	GRP plywood	Plastic coated, glass-fibre reinforced plywood	PG
05380	Plymetal	Material is plywood, faced with metal of no specific type on both sides	PM
05400	Plastics	Plastics, unspecified type	PU
05410	Plastics reinforced	Plastics reinforced with fibres	PE
05420	Insulation material unspecified	Insulating material in slab	IS

Numerical code	Name	Description	CEDEX code
05430	Insulation material <i>in situ</i>	Insulating material injected	II
05440	Rubber, unspecified	Rubber, unspecified type	RU

Annex F (normative)

Codes — Repair type

(see 4.1 and 4.2)

Numerical code	Name	Description	CEDEX code
06010	Abrasive clean and paint	Clean mechanically with abrasive grit or shot and paint	AB
06020	Adjust	Adjust a mechanical part or system (usually brakes) to improve performance	AJ
06030	Air	Inflate or deflate tyres to correct pressure	AR
06040	Air clean	Clean a component or equipment with high pressure air	AC
06050	Blank out	Remove a ventilator and "blank out" the panel behind	BU
06060	Brand	Apply a name/initial or other mark to tyres to denote ownership or other information	BD
06070	Chemical clean	Clean a component with chemical wash	CC
06075	Deodorize	Neutralize odour in container	DO
06080	Drain	Drain the system	DR
06090	Drain and fill	Drain the system and fill with appropriate fluid	DF
06100	Inspect and report	Inspect equipment or component for proper function, damage or reason for non-operation, and re-estimate. An additional report will follow on completion	IP
06110	Free	Free a frozen, seized or stiff component by means of force, lubricants or heat	FR
06115	Handling	Equipment must be handled in order to make available, but without other repair action	HN
06120	Insert	Remove and replace part of the cross-sectional profile of a component over its entire length and/or width. The replacement portion is butt-welded to the original component	IT
06125	Install	Fit a component for the first time	IN
06130	Lubricate	Apply lubrication	LC
06135	Modifications, miscellaneous	Alter a component such that its specification is changed	MD
06138	Not applicable	Condition for which no specific repair type applies	ZZ
06140	Overlapping partial section	Remove and replace part of the cross-sectional profile of a component over its entire length and/or width. The replacement portion is overlapped with and fillet-welded to the original component. The exterior of the patch is continuously welded to the original component. The interior may be continuously or skip-welded with sealer applied to seams between skip welds	OP

Numerical code	Name	Description	CEDEX code
06150	Paint	Apply paint	PA
06155	Overlay	Cover a surface with a thin layer of the same or similar material	OX
06160	Partial refurbishment	Remove localized corrosion and repaint the surface of the equipment fully or partially	PR
06170	Patch	Remove and replace a part of the cross-sectional profile of a component, over only part of the component's length and/or width. A patch is overlapped with and fillet-welded to the original component. The exterior of the patch is continuously welded to the original component. The interior may be continuously or skip-welded with sealer applied to the seams between skip welds	PT
06175	Patch and foam	Patch as indicated in 06170, and also remove and replace underlying insulating foam	PX
06180	Preventive maintenance	Maintenance carried out under the owner's instruction	VM
06190	Re-align	a) Remove or unfasten a component, usually doors, and refit to bring into alignment b) Move chassis tandem to bring into alignment	RA
06200	Rebuild	Strip, clean, lubricate, and reassemble a mechanical component	RB
06205	Re-bush	Remove and refit a bush(ing) into a component	RU
06210	Recharge	Supply a full charge of fluid to system	CH
06220	Recondition/refurbish	Prepare surface of equipment and repaint in accordance with the owner's instructions	RC
06230	Refit	Refit a removable component to its proper position	FT
06240	Re-glass	Repair surface and veneer cracks or damage to GRP panels	RG
06250	Re-mark	Replace markings	MK
06260	Remove and dispose	Remove and dispose of debris, dunnage, or packing material	RD
06270	Repairs prior to refurbishment	Repairs ordered by owner prior to refurbishment	PV
06280	Remove (without replacement)	Remove and not replace a component	RM
06290	Remove and refit	Remove and refit after repair	RR
06295	Remove glue and tape	Clean surfaces of glue and tape, including their residues	GT
06297	Remove markings	Remove unwanted labels, marks, logos, and graffiti	MV
06300	Replace	Remove and replace the complete cross sectional profile of a component over its entire length and width	RP
06310	Re-rate	Modify data relating to maximum gross mass or tare on any data plate or weight marking	RT

Numerical code	Name	Description	CEDEX code
06315	Resecure	Reapply or tighten fasteners on loose components	RE
06320	Rewire	Repair an electrical component or system by rewiring	RW
06325	Sand	Smooth a surface by sanding	SD
06330	Seal/reseal	a) Repair pin holes in a tarpaulin cover or tilt using sealant b) Apply sealant to or around component	SE
06340	Section	Remove and replace the complete cross-sectional profile of a component over part of its length and/or width	SN
06345	Section and foam	Section as indicated in 06340, and also remove and replace underlying insulating foam	SF
06350	Splice	Repair by section using rivets with, usually, a doubler piece or backing plate at the joint	SI
06360	Straighten	Repair by straightening	GS
06370	Straighten and resecure	Repair by straightening and resecuring the component when repaired	RS
06380	Straighten and weld	Repair by straightening a component and rewelding it into position	GW
06390	Steam clean	Clean the component, usually the floor, using high pressure steam	SC
06400	Surface preparation and paint	Clean and prepare the surface and apply paint	PS
06410	Sweep	Clean the component, usually the floor, by sweeping	WP
06420	Top up	Refill fluid to correct level	TP
06430	Water wash	Clean the component, usually the floor, using water	WW
06440	Weld	Repair by welding	WD
06450	Grind and weld	Repair by grinding and welding	XW
06500	Temporary repair	Repair for temporary securement of cargoworthiness until a permanent repair can be made at a suitable repair shop	TR

Annex G (normative)

Codes — Measure unit specifier; repair size dimension and work scales

(see 4.1 and 4.2)

Numerical code	Name	Description	CEDEX code
G.1 Measure unit specifier			
07010	Inches	Measurement is in inches	INH
07020	Feet	Measurement is in feet	FOT
07030	Millimetres	Measurement is in millimetres	MMT
07040	Centimetres	Measurement is in centimetres	CMT
07050	Metres	Measurement is in metres	MTR

G.2 Size of repair

Size of repair, where required, is defined by dimensions of either length, length and height, or length and width.

EXAMPLE

Length only	6
Length and height	1500 x 100
Length and width	2 x 1

G.3 Work scale

The work scale is a factor related to the standard time to reflect ease or difficulty of repair. The factor is a percentage shown as 2-numeric. In normal cases it may range from 05 (i.e. 50% easier work) to 10 (i.e. standard time) to 15 (i.e. 50% over the standard time needed).

Annex H (normative)

Codes — Responsibility

(see 4.1 and 4.2)

Numerical code	Name	Description	CEDEX code
08010	Manufacturer	The repair is necessary to correct a manufacturer's defect outside the warranty or guarantee period	H
08020	Depot	The repair is necessary to correct damage/negligence by depot and is for the account of the depot	D
08030	Terminal	The repair is necessary to correct damage/negligence by terminal and is for the account of the terminal	S
08040	User	The repair is for the user's account	U
08050	Owner	The repair is for the owner's account	O
08060	Third party	The repair should be charged to the party responsible, usually not the owner or user	T
08070	Warranty	The repair is required under a manufacturer's warranty within the agreed period	W
08080	DPP/insurance	The repair costs are covered by insurance or an insurance programme	I

Annex J (informative)

Codes — Party identification and location

(see 4.1 and 4.2)

As a complement to this part of ISO 9897, a directory of names and addresses of companies participating in standardized communication rules for commercial transaction related to containers will be developed.

The International Container Bureau has been nominated to act as the Registration Authority for the party identification and location codes:

Bureau International des Containers (BIC)
167, rue de Courcelles
F-75017 Paris
France

Telephone: +33-1-47 66 03 90
Telefax: +33-1-47 66 08 91

The code of business names and addresses will consist of a

- 5-alpha code which is the LOCODE for the location nearest the business address, plus a
- 4-alpha code for the identification of the individual company.

The International Container Bureau will publish an updated directory of business names and addresses and codes at least once a year.

Annex K (normative)

Codes — Components of Container

(see 4.1 and 4.2)

NOTES

- 1: Material is assumed to be of normal type for the design and type of container unless specified otherwise in the material code.
- 2: The number in brackets under the CEDEX code is the number of the figure in which the component is illustrated (see figures K.1 to K.7).

Numerical code	Name	Description	CEDEX code
K.1 Components of general purpose, open top, and platform containers			
K.1.1 Bow (roof)			
10200	Roof bow	Members mounted transversely across the top of a container and either forming part of a rigid roof structure or supporting flexible, removable covers, in which case the members are commonly removable, or so designed as to slide to facilitate the loading of cargo through the top of the container [from ISO 830]	RBO (K.2)
10210	Roof bow securement device	Device at the top rail to support the ends of the roof bow	RBS (K.2)
10220	Roof bow holder	Device at the top rail to support the ends of a detachable roof bow	RBH (K.2)
10225	Roof bow pin	Pin on top rails used to secure removable roof bow	RBP
K.1.2 Cargo securing device			
10230	Cargo securing device assembly	Cargo tie-down fittings fixed to any part of the container for the attachment of straps or other devices to restrain movement of cargo	LSA (K.1)
10240	Lashing bar	Bar for the attachment of straps or other devices to restrain movement of cargo	LSB (K.1, K.2)
10250	Lashing ring	Part of the securing device assembly to which straps or other lashings are secured to restrain cargo movement	LSR (K.1)
K.1.3 Corner posts			
10260	Corner post assembly	Vertical structural member at either side of an "end frame" of a container joining a top and a bottom corner fitting (and thereby forming a "corner structure") [from ISO 830]	CPA (K.2, K.3)
10270	Clip on gen set clamp socket	Fitting in the corner post into which the lower part of a clip on a generator set is secured	COS (K.2)

Numerical code	Name	Description	CEDEX code
10280	Corner fitting	Fittings located at the corners of containers providing means of supporting, stacking, handling, and securing the container [from ISO 830]	CFG (K.2, K.3)
10290	Corner post gusset	Reinforcement between the corner fitting and the corner post, particularly in a platform-based container	CPG (K.1)
10300	Corner post inner piece	Inner part of a two- or multi-component corner post	CPI (K.3)
10310	Corner post J-bar	Portion of the exterior part of the rear corner post that encircles the door hinges	CPJ (K.3)
10320	Corner post hinge lug	Hinge component permanently attached by welding to the rear corner post	CPL (K.3)
10330	Corner post outer piece	Outer part of a two- or multi-part corner post	CPO (K.3)
10340	Corner post reinforcement	Vertical reinforcement of a corner post, normally welded to the corner post outer part	CPR (K.3)
10350	Corner post single piece	Single component of a one-piece corner post	CPS (K.2)
10360	Corner post whole section	Complete transverse section of a corner post	CPT (K.3)

K.1.4 Cross-members (including outriggers)

10370	Cross-member assembly	Components in the base structure of a container supporting the floor	CMA (K.1)
10380	Cross-member fixing plate	Components welded to the cross-member ends for their securing to the bottom side rails by rivets or special bolts	CMF (K.1)
10390	Cross-member lower flange	Lower flange of a cross-member	CML (K.1)
10400	Cross-member upper flange	Upper flange of a cross-member	CMU (K.1)
10410	Cross-member web	Web of a cross-member	CMW (K.1)
10420	Cross-member whole section	Complete transverse section of a cross-member	CMS (K.1)
10425	Outrigger	Short cross-member extending between bottom side rail and gooseneck tunnel rail	CMO

K.1.5 Door gaskets

10430	Gasket assembly	Seal running round the edge of a door and other fittings needed to ensure its proper fixing	GTA
10440	Gasket retainer strip	Strip running inside a gasket around a door through which fasteners are passed to secure the gasket to the door edge	GRS (K.3)
10450	Inner gasket	Inner gasket of a multi-gasket system, usually on thermal containers	GIN (K.3)

Numerical code	Name	Description	CEDEX code
10460	Inner/outer gasket	Whole part of a multi-leaf gasket, combining the effects of both the inner and outer gaskets, usually found on thermal containers	GIO (K.3)
10470	Outer gasket	Outer part of the multi-leaf gasket, usually on thermal containers	GTO (K.3)
K.1.6 Door hinges			
10480	Hinge assembly	Fitting on which the door rotates	HGA (K.3)
10485	End frame hinge assembly	Rotating assembly supporting collapsible end frame of platform-based container	EFH
10490	Hinge blade	Hinge component that is secured to the door and holds the pin	HGB (K.3)
10500	Hinge pin	Hinge component attaching the blade to the lug	HGP (K.3)
10505	Door hinge bush(ing)	Bush(ing) inserted into door hinge for smooth operation	DHB
K.1.7 Door gear			
10509	Door gear, complete	Set of door-locking rods, cams and cam retainers (keepers), including mounting hardware, for a single door	DGR
10510	Locking-bar assembly	Complete mechanism that keeps the door secured closed	LBA (K.3)
10520	Locking-bar bracket	Device attaching the locking bar to the top and bottom of a door, usually containing a bush(ing)	LBB (K.3)
10530	Locking-bar cam	Part of the door securing device that engages the retainer which, by a lever action, forms the cam lock	LBC (K.3)
10540	Locking-bar guide	Component, intermediate to the locking-bar brackets, which holds the locking bar to the door in proper alignment	LBG (K.3)
10550	Locking-bar handle	Component attached to the locking bar rod by mean of the lug which, by turning, operates the assembly	LBH (K.3)
10560	Locking-bar lug	Component, part of the locking bar rod to which the locking bar handle is secured	LBL (K.3)
10570	Locking-bar rod (tube)	Vertical shaft or rod to which the cam locks are fitted	LBR (K.3)
10575	Locking-bar nut	Nut used to secure locking-bar hardware	LBN
10576	Locking pin - Sill to corner fitting	Pin securing sill to corner fitting for collapsible end frame of platform-based container	LPS
10577	Locking mechanism - Sill to end frame	Hardware used to secure sill to end frame for collapsible end frame of platform-based container	LMS
10578	Locking pin - End frame to side rail	Pin securing end frame to side rail for collapsible end frame of platform-based container	LPP

Numerical code	Name	Description	CEDEX code
10580	Door customs flap	A protective cover over the customs seal	LBF (K.3)
10585	Door with hardware - flat	Entire door that is fitted with flat panels, including stiffeners, hardware (except hinges) and gaskets	DFA
10586	Door with hardware - corrugated	Entire door that is fitted with corrugated panels, including stiffeners, hardware (except hinges) and gaskets	DCA
10587	Door retainer lug	Mounting bracket, attached to door panel, that holds the door retainer	DRL
10588	Door security plug, left hand door	NOTE - Preliminary assignment; to be defined in a future edition	DSO
10590	Door handle lock assembly	Device which can be sealed for compliance with the CCC and which locks the door in the closed position	DHL (K.3)
10600	Door handle catch	Component of the door handle lock assembly, 10590, fixed to the door and which the door handle is engaged when the doors are closed	DHC (K.3)
10610	Door handle retainer	Component of the door handle lock assembly, 10590, which rotates and holds the door handle in the closed position, and through which the seal is secured	DHR (K.3)
10620	Door customs seal point	Holes in the door handle catch and door handle retainer through which the customs seal is secured	DCS (K.3)
10630	Door retainer	Device which retains the door in the open position	DRT (K.2, K.3)
10635	Door stop/slam (security) plate	Door edge plate preventing opening the left-hand door unless the right hand door is open	DPL
10636	Door plate rivets	Rivets used to attach door plate	DPR
10640	Anti-rack device	Device which reinforces the securement of the locking bar assembly and limits the racking of the door frame	ARD (K.3)
10650	Anti-rack omega	Anti-rack device in the form of an omega reinforcement running vertically, up the edge of the back door, which is connected to the horizontal members of the door frame by spigots	ARO (K.3)
10660	Anti-rack plate	Anti-rack device, consisting of a plate at the top and bottom of the right-hand door which is connected to the left-hand door and door frame by spigots	ARP (K.3)
10670	Anti-rack spigot	Device in the transverse members of a door frame, and the left-hand door in the plate system, over which the anti-rack device fits	ARS (K.3)
10675	Flat rack spring	NOTE - Preliminary assignment; to be defined in a future edition	FRS

**Doors/Panels
End transverse members**

See K.1.11, Panels
See K.1.13, Rails

K.1.8 Floor (wooden)

10680	Wood floor assembly	Complete wooden floor	FWA (K.1)
-------	---------------------	-----------------------	-----------

Numerical code	Name	Description	CEDEX code
10690	Plain plank	Flooring of wood plank	FPB (K.1)
10700	Hat section	Hat or omega steel section running longitudinally, sometimes used with either plywood or plank floorings	FHS (K.1)
10710	Laminated plank	Flooring of (vertically) laminated plank	FLB (K.1)
10720	Plywood panel	Flooring of plywood	FPP (K.1)
10730	Threshold plate	Steel plate secured inside doorway to protect flooring against cargo handling equipment	FTP (K.1)
10740	Combination steel and wood floor	NOTE - Preliminary assignment; to be defined in a future edition	FWS

Floor panel (insulated) See clause K.5, Components of thermal containers

K.1.9 Forklift pockets

10850	Forklift pocket assembly	Reinforced pockets running transversally across the base of a container, piercing the bottom side rails at prescribed positions to permit the entry of the tines of forklift devices for lifting and carrying the container	FLA (K.1)
10860	Forklift pocket lower flange	Flange formed at the bottom edge of the forklift pocket	FLL (K.1)
10870	Forklift pocket strap	Plate welded to the bottom of each forklift pocket entrance	FLS (K.1)
10880	Forklift pocket top plate	Plated welded to the top of the forklift pocket	FLP (K.1)
10890	Forklift pocket upper flange	Flange formed at the top edge of the forklift pocket	FLU (K.1)
10900	Forklift pocket web	Web or side of the forklift pocket	FLW (K.1)
10910	Forklift pocket whole transverse section	Complete transverse section of a forklift pocket	FLT (K.1)

K.1.10 Hatches

10930	Discharge hatch assembly	Hatch, when opened, which is used to discharge bulk cargo	HAD (K.3)
10940	Loading hatch assembly	Hatch, when opened, through which bulk cargo is loaded	HAL (K.2)
10950	Hatch cover	Cover that closes off a hatch	HCV (K.2, K.3)
10960	Hatch gasket	Gasket that seals the hatch cover	HGT (K.3)

Numerical code	Name	Description	CEDEX code
10970	Hatch discharge sleeve	Sleeve fitted to the discharge hatch for discharge	HDS (K.3)
10980	Hatch handle catch	Component of the hatch handle locking assembly, fixed to the hatch cover, through which the customs seal is secured	HHC (K.2, K.3)
10990	Hatch hinge	Fitting on which the hatch cover rotates	HHG (K.2, K.3)
11000	Hatch handle retainer	Device which retains the hatch-locking handle in the closed position, and through which the customs seal is secured	HHR (K.3)
11010	Hatch customs point	Holes in the hatch handle catch and hatch handle retainer through which the customs seal is secured	HCP (K.2, K.3)
11020	Hatch-locking bar	Bar which holds the hatch cover closed	HLB (K.2)
11030	Hatch-locking handle	Handle which operates the hatch-locking bar	HLH (K.2, K.3)
11040	Hatch-locking mechanism	Device that keeps the hatch cover secured closed	HLM (K.2, K.3)

K.1.11 Panels

11200	Panel assembly	Complete panel (of all types)	PAA (K.2)
11210	Panel - behind hinge	Section of the door panel behind the hinge	PBH (K.3)
11240	Panel - fixing strip	Metal strip securing the edge of the plywood lining to the frame of a container	PFX (K.3)
11320	Panel - plywood lining	Plywood panel that lines the inside of dry cargo and other types of containers	PPW (K.2)
11330	Panel - plymetal	Panel, usually a door panel, made of plywood faced on both sides with metal sheet	PPM (K.3)
11340	Panel - steel corrugation	Panel formed of corrugated steel	PSC (K.2)
11345	Flat steel panel	Panel formed of flat steel	PSF
11350	Panel - inner face	Inner face of a single-piece panel	PIP (K.3)
11360	Panel - outer face	Outer face of a single-piece panel	POP (K.3)

K.1.12 Panel equivalents

11380	Side bar socket	Socket in the stanchion and end frames to support a side bar	SBS (K.1)
11390	Side bar	Horizontal bar in a platform-based container connecting stanchions and end frames to provide cargo restraint	SBR (K.1)
11400	Bulkhead	Demountable panel which acts as an end wall in a platform-based container to provide cargo restraint	PBK (K.1)

Numerical code	Name	Description	CEDEX code
11410	Stanchion	Vertical members at each side rail in a platform-based container to provide cargo restraint	STC (K.1)
11420	Stanchion lashing chain	Lashing chain for the stanchion lashing system, 11440	SLC (K.1)
11430	Stanchion chain hook	Hook for the stanchion lashing system, 11440	SCH (K.1)
11440	Stanchion lashing system	System used in open-side containers to provide mutual support to stanchions by means of chains and hooks running between stanchions on opposite sides	SLS (K.1)
11445	Stanchion pocket	Recess in the bottom side rail of a platform container that holds a stanchion in place	STP
11450	Side gate assembly	Removable frame system used for cargo restraint	SGA (K.1)
11460	Side gate frame	Frame of the gate system	SGF (K.1)
11470	Side gate mesh	Mesh used inside the frame of a gate system	SGM (K.1)
11480	Side gate pin	Pin used in locking a gate in position	SGP (K.1)
11490	Side post (inner)	Reinforcing vertical member, placed between top and bottom, side or end rails, on the inside of the panel, in a side or end wall	SPI (K.2)
11500	Side post (outer)	Reinforcing vertical member, placed between top and bottom, side or end rails, on the outside of the panel, in a side or end wall	SPO (K.1)

K.1.13 Rails (including end transverse members and tunnel rails)

11510	Rails assembly	Longitudinal and transverse structural members at the bottom, top, and sides of the container and sides of the tunnel	RLA (K.1, K.2)
11520	Cam keeper	Device at the rear top and bottom end transverse member which retains the locking bar cam when the locking bar mechanism is locked closed	RCK (K.3)
11530	Rail doubling plate	Additional plate attached to the container roof, adjacent to the top corner fittings, providing protection from misuse of spreader equipment	RDP (K.2)
11540	Rail gusset	Reinforcement plate either between the corner fitting and side or end rail, or inside the front and rear lower rails	RLG (K.1, K.2, K.3)
11550	Rail inner web	Closing plate on the inside of the front and rear lower rails. Used as an alternative to the rail gusset, 11540	RIW (K.3)
11555	Rail cone protector recess	Recess or cut-out in a front or door sill web and lower flange, adjacent to corner fitting, used to prevent damage to the rail when securing container to twist lock or stacking cone	RCI
11560	Rail lower flange	Lower flange of bottom side and end rails	RLF (K.1, K.3)
11570	Rail upper flange	Upper flange of top, side and end rails	RUF (K.3)
11580	Rail web	Web side and end rails	RLW (K.1, K.3)

Numerical code	Name	Description	CEDEX code
11585	Gooseneck tunnel rail	Side longitudinal rail of gooseneck tunnel	RTL
11590	Rain gutter	Part of, or attachment to, rear upper end rail to divert water away from door frame	RNG (K.3)
11600	Stanchion socket	Socket which holds the stanchion, 11410	SST (K.1)
11610	Rail doubler plate	Doubler plate on top and bottom rails	RUP (K.3)
11620	Rail whole section	The complete transverse section of a rail	RLT (K.3)
11623	Vertical door stiffener panel	NOTE - Preliminary assignment; to be defined in a future edition	DSM
11625	Door stiffener - bottom edge	Horizontal reinforcing member of door, installed on bottom edge	DSB
11626	Door stiffener - centreline edge	Horizontal reinforcing member of door, installed along vertical midline of door	DSC
11627	Door stiffener - hinge side edge	Vertical reinforcing member of door, installed along hinge side	DSH
11628	Door stiffener - top edge	Horizontal reinforcing member of door, installed on top edge	DST
11630	Floor support angle	Angle attached to bottom side rail which supports edge of floor	FSA
11640	Steel plate of combination floor	Longitudinal steel floor sections, used in conjunction with alternating wood sections	FSP
11650	Header extension plate	Extended header plate used to protect roof from damage	HEP
11660	Rail - interior component	Interior portion of multi-piece rail	RLI
11661	Rail - exterior component	Exterior portion of multi-piece rail	RLE
11665	Swinging or removable header	Upper transverse rail that is hinged and/or removable	RRT
11666	Rear header latch	Latch securing swinging rear header in closed position	RHL
11667	Rear header-hinge lug	Hinge lug for swinging rear header	RLL
11668	Header pin handle	Hinge pin on removable header	HPH
11669	Header pin chain	Chain securing header pin handle to removable header member	HPC
11670	Piggybacker rail	Reinforcement on side bottom rail for piggybacker lifting	RPP

Numerical code	Name	Description	CEDEX code
K.1.14 Tarpaulin			
11680	Tarpaulin assembly	Tarpaulin, cover or tilt for open-top and open-side containers	TNA (K.1, K.2)
11690	Tarpaulin belt	Webbing or similar providing support to a tarpaulin (longitudinally), in addition to roof bows (transversally)	TNB (K.2)
11700	Tarpaulin rubber cord	Rubber cord secured to the tarpaulin and TIR cord ring under tension to tighten tarpaulin	TNC (K.2)
11710	Tarpaulin customs seal point	Device to permit the ends of the TIR cord to be customs sealed	TNS (K.2)
11720	Tarpaulin grommet	Ring set in the tarpaulin that fits over the TIR cord ring	TNG (K.2)
11730	Tarpaulin fixing strip	Strip used to fix tarpaulin semi-permanently on some open-top and open-side containers	TNX (K.2)
11735	Tarpaulin pinhole	Hole in tarpaulin for securing pin	TPH
11740	TIR cord	Cord specified by customs convention which, passed through the TIR cord ring, seals the container	TIC (K.2)
11750	TIR cord ring	Ring set in the container which secures the tarpaulin by means of the grommets, and which takes the TIR cord	TIR (K.2)
K.1.15 Tunnel			
11760	Tunnel assembly	Recess in the front portion of a container understructure to accommodate the raised portion of a gooseneck chassis	TUA (K.1)
11770	Tunnel cross-member	Transverse members providing support to the tunnel plate	TUC (K.1)
11780	Tunnel plate	Steel plate separating the tunnel recess from the interior of the container	TUP (K.1)
11790	Tunnel bolster	Transverse member which supports the rearmost portion of the tunnel	TUB (K.1)
	Tunnel rail	[See K.1.13, Rails]	
	Tunnel outriggers	[See K.1.4, Cross-members]	
K.1.16 Ventilators			
11800	Ventilator assembly	Device permanently attached to the side (or front) panel of a container which permits air exchange with the ambient atmosphere	VRA (K.2)
11810	Ventilator baffle	Baffle inside the ventilator which prevents ingress of sea water	VRB (K.2)
11820	Ventilator cover	Outermost portion of the ventilator, which is a part of the exterior of the container	VRR (K.2)
11830	Ventilator grid	Lower portion of the ventilator which is either pierced with holes or formed with mesh to permit passage of air	VRG (K.2)

Numerical code	Name	Description	CEDEX code
K.1.17 Miscellaneous			
11840	Fumigating nozzle	Nozzle set in the side (or front) panel which permits fumigation of the container	FUN (K.2)
11850	Joint between components	Junction where components are welded or fastened together	VJT
11860	Stacking cone and chain - fixed or removable	Cone-shaped projection, placed in a corner fitting of a container, used to secure the corresponding corner fitting of a container stacked above it	SCC
11890	(Not applicable)	(Dummy code used when a component code is not applicable)	ZZZ
K.1.18 Hardware			
11900	Hardware	Screws, nuts, and bolts	HWR
11910	Lock bolt	Structural fastener secured with a collar that is swaged to the bolt	LBT
K.1.19 Major Assemblies			
12000	Cargo container	Entire container	MCO
12010	Sidewall - complete	Complete assembly of all sidewall panels, including posts and stringers, on one side of a container	SAA
12020	Endwall - complete	Complete assembly of all endwall (not door) panels, including posts and stringers, at one end of container	EAA
12030	Roof - complete	Entire roof assembly, including bows if applicable	RAA
12040	Understructure - complete	Entire understructure of cross-members, forklift pockets, and gooseneck tunnel components (as applicable)	UAA
12045	Drop (collapsible) end frame	End frame structural components in a hinged assembly that may be lowered to the floor surface of a platform-based container	DEF
12050	Door, complete (without hardware)	Entire door, including stiffeners, but not including hardware and gaskets	DAA
12060	Door, complete (with hardware)	Entire door, including stiffeners, hardware (except hinges), and gaskets	DAH
K.4 Components applicable to marking			
K.4.1 ISO marking			
40010	Country code	Code designating the country of registration of the owner, in accordance with ISO 3166	MCC (K.3)
40020	Identification marking set	Owner's code, 40040; serial number and check digit, 40050; size and type code, 40060; in accordance with ISO 6346	MIS (K.2)

Numerical code	Name	Description	CEDEX code
40030	Mass marking	Maximum gross and tare weights, in accordance with ISO 6346; payload	MMI (K.3)
40040	Owner's code	Owner's mark, in accordance with ISO 6346	MOC (K.3)
40050	Serial number and check digit	Number of the equipment plus check digit, in accordance with ISO 6346	MSN (K.3)
40060	Size/type marking	Code designating the size and type of the equipment, in accordance with ISO 6346	MST (K.3)
40070	Height marking	Optional height marks for containers of height greater than 2,6 m (8,5 ft), in accordance with ISO 6346:1984, Annex H	MHT
40072	High-cube stripe	Alternating oblique striped marking fitted to upper rails used to distinguish 1AAA, 1BBB and 1CCC (high-cube) containers	MHC
40080	Caution marking	Sign warning of overhead electrical danger, in accordance with ISO 6346:1984, Annex C	MCA
40090	Consolidated data plate	Single consolidated data plate prepared according to a means of combining various labels and plates provided for in ISO 6359	MPD
40100	Markings - full set	Entire set of markings on a container	MFS
40110	Markings - single digit/character	Single digit/character of a serial number marking	MSD
40115	UIC decal	Marking fitted to the side of a container indicating registration of the container with a member carrier of the Union Internationale des Chemins de Fer (UIC)	MUI
K.4.2 Other markings			
40200	CSC plates	Plate on which data required by the safety convention is displayed	MPS (K.3)
40210	ACEP marking	Marking required of a container that is operated under an approved continuous examination programme prescribed in the CSC	MCE
40220	Class survey marking	Marking of classification societies and other organizations approved by the competent authority	MCS
40230	Customs plate	Plate on which customs approval data is displayed	MPC (K.3)
40240	Owner's plate	Plate on which the owner's name, and sometimes address, is displayed	MPO (K.3)
40250	Manufacturer's plate	Plate on which the manufacturer's name and/or logotype, and sometimes other data, is displayed	MPM (K.3)
40260	Cargo label plate	Area, usually marked in black, for cargo labels	MPL (K.2)
40270	Tank plate	Plate on which data relating to tank containers, including a label and caution mark described in the IMDG Code, is displayed	MPT
40280	Timber chemical treatment	Plate on which data relating to quarantine treatment of exposed wooden components is displayed	MTT (K.3)
40290	Other markings	Any unspecified marking	MRU
40300	Owner's logo	Owner's logotype	MOL (K.2, K.3)

Numerical code	Name	Description	CEDEX code
K.5 Components of thermal containers			
K.5.1 Air opening			
50010	Air opening assembly	Complete porthole assembly to permit passage of cold/hot air to and from the porthole thermal container	AOA (K.2)
50020	Valve retainer cam	Porthole valve retaining the cam (also called regulating knob) for the valve closing operation (detail of the air opening assembly, 50010)	VVR (K.2)
50030	Valve disk	Porthole valve disk or valve plate (detail of the air opening assembly, 50010)	VVD (K.2)
50040	Valve foil	Diffuser to ease/ensure good air distribution behind the air screen; in some cases called "distance ring" (detail of the air opening assembly, 50010)	VVF (K.2)
50050	Valve gasket	Valve disk gasket to ensure proper airtightness (detail of the air opening assembly, 50010)	VVG (K.2)
50060	Valve handle	Valve-operating handle open/closed (detail of the air opening assembly, 50010)	VVH (K.2)
50070	Valve-handle seal	Valve-handle seal to ensure proper closure in compliance with the CCC (detail of the air opening assembly, 50010)	VVS (K.2)
50080	Valve ring	Valve rod flange for mounting on the air screen flap (detail of the air opening assembly, 50010)	VVI (K.2)
50090	Valve spring	Valve rod spring to maintain in open position (detail of the air opening assembly, 50010)	VVP (K.2)
50100	Valve axle (rod)	Valve rod on which the valve can move from closed to open position and <i>vice versa</i> (detail of the air opening assembly, 50010)	VVA (K.2)
50110	Porthole collar	Collar that surrounds the post in a porthole thermal container (detail of the air opening assembly, 50010)	PHC (K.2)
50120	Port (modified atmosphere)	Port to permit injection of special gases into thermal containers to modify the atmosphere	POM (K.2)
50130	Plug (modified atmosphere)	Plug to close port to permit injection of special gases into thermal containers to modify atmosphere	PLM (K.2)
50135	Modified-atmosphere door curtain assembly	Complete assembly of door curtain, seal and retaining track	RCM
50136	Modified-atmosphere door curtain	Flexible air seal to retard gas transfer through door	DCU
50137	Modified-atmosphere snap ribbon seal	Seal holding door curtain in place in modified-atmosphere system	SRS
50138	Modified-atmosphere port/plug assembly	Complete assembly for modified-atmosphere port and plug	POA

Numerical code	Name	Description	CEDEX code
K.5.2 Air screen			
50150	Air screen assembly	Air screen intermediate panel assembly separating the air inlet from the air outlet	ASA (K.2)
50160	Air screen flap	Hinged air screen flap on which the valve assembly is mounted permitting access to the valve and behind inlet or outlet screen	ASF (K.2)
50165	Air screen gasket	Gasket for air screen flap	ASG
50170	Air screen hinge	Air screen flap hinge	ASH (K.2)
50180	Air screen lock	Air screen flap locking device	ASL (K.2)
50190	Air screen panel	Inlet or outlet air screen panel to ensure proper air distribution in the container	ASP (K.2)
50200	Stiffener/splitter	Inlet or outlet air screen panel stiffener or distance piece to ensure screen flap or valve position as well as air space behind the screen	STF (K.2)
K.5.3 Air duct			
50250	Air duct	Component which allows proper air circulation throughout the thermal container	ADU (K.2)
K.5.4 Flooring			
50300	T-floor assembly	An aluminium flooring of T-section which permits air-flow, used in thermal containers	TFA (K.1)
50310	T-floor casting	An aluminium casting which forms the rear end of the T-floor	TFC (K.1)
50320	T-floor drain	Drain hole used in thermal and other containers	TFD (K.1)
50322	T-floor drain pan	Pan or sump used to catch fluids drained from the interior of a thermal container	TPN
50330	T-floor end seal	Seal that closes off the joint between the T-floor and the rear bottom end transverse member (rear sill)	TFS (K.1)
50340	T-floor plate	Front angled plate or curved moulding that seals the front of the T-floor from the refrigerating machinery air outlet	TFF (K.1)
50350	T-floor gutter	Curved moulding that seals the side wall panel from the bottom edge of the T-floor	TFG (K.1)
50360	T-floor plank	Section of T-floor	TFP (K.1)
50370	T-floor strip	Transverse reinforcement on top of the T-floor at either its front or rear end	TFI (K.1)
50380	T-floor angle bar	Angle that forces air from the refrigerating machinery down through the T-floor	TFB (K.1)
50385	Drain plug assembly	Plug and chain assembly for floor drain	DRA
50386	Drain plug	Plug for floor drain	DRP
50389	Subfloor	Panel assembly covering underside of floor insulation	PAA
50395	Self-opening drain (Kazoo)	Flexible bladder, fitted to the underside of a T-floor drain, that opens and reseals by hydrostatic pressure to expel fluids that drain from the interior of a thermal container	DKK

Numerical code	Name	Description	CEDEX code
K.5.5 Panels			
50450	Panel edge profile	Profile that closes off the edge of an insulated panel, usually a door panel	PEP (K.1, K.3)
50460	Panel-frame	Profile that frames the door, usually an insulated type	PAF (K.3)
50470	Battens in insulated panel	Battens of raised or recessed type in the interior lining of thermal container side and door panels	PBT (K.3)
50480	Panel inner cladding	Inner lining of an insulated panel	PIC (K.2, K.3)
50490	Insulation material	Material, usually foam, used for insulation	PIM (K.1, K.2)
50500	Panel - internal stiffener	Usually in thermal container side walls	PIS (K.2)
50510	Panel - joint capping	Curved moulding or angle that closes off join between insulated side wall and roof panels	PJC (K.2)
50520	Panel - joint profile	Profile that secures the panel joint capping to the side wall and/or roof panel	PJP (K.2)
50530	Panel - outer cladding	Material on the outside of an insulated panel	POC (K.2, K.3)
50540	Panel transverse section	Whole transverse section of an insulated panel	PAT (K.2, K.3)
K.5.6 Miscellaneous			
50600	Hanging rail assembly	Rail for hanging cargo in the container	HRA (K.2)
50610	Hanging rail bar	Bars for hanging cargo in the container	HRB (K.2)
50620	Hanging rail hook	Hook for hanging cargo in the container	HRH (K.2)
50630	Clip-on generator set mounting hole, upper	Receptacle in front header for clip-on generator set clamping device	CHU
50640	Clip-on generator set mounting hole, threaded, lower	Threaded receptacle in front corner post for clip-on generator set clamping device	CHL
K.6 Components of refrigeration units			
K.6.1 Compressor - Location: MQNN			
60010	Compressor, complete (with motor)	Compressor assembly and its driving electric motor	ASY (K.4)

Numerical code	Name	Description	CEDEX code
60020	Open compressor (without motor)	Compressor assembly without its driving electric motor	QAS (K.4)
60030	Shaft	Cylindrical bar to transmit motion by rotation	SFT (K.4)
60033	Shaft seal	Seal between compressor shaft and housing	QSS
60034	Crankshaft	Rotating member that transmits force to pistons	CSF
60035	Bearing, crankshaft	Support which holds crankshaft in place	BSF
60036	Gasket, crankshaft assembly	Seal to prevent leakage between crankshaft and housing	SSF
60040	Cylinder head	Cover of the piston chamber above the valve plate	CYH
60050	Cylinder unloader	Device to cut off the cylinder or to allow communication between high pressure and low pressure to decrease the compressor capacity	CYU
60060	Unloader solenoid	Solenoid coil which operates opening/closing of one cylinder unloader	CYS (K.4)
60070	Cylinder head cover gasket	Gasket to seal the cylinder head cover on the compressor body	CYG (K.4)
60080	Cylinder	Chamber in which one piston moves	CYA (K.4)
60090	Piston	Sliding piece to compress refrigeration gas in the cylinder	PTA (K.4)
60100	Piston rod	Bar between the shaft and the piston	PTR (K.4)
60110	Piston ring	Metallic circular spring with a high relative outward expanding strain used around the piston to make a gastight joint	PTB (K.4)
60120	Compressor pulley	Wheel to transmit motion to the compressor shaft	PUQ (K.4)
60130	Motor pulley	Pulley to transmit motion from the motor shaft	PUM (K.4)
60135	Drive belt	Tensioning device to impart torque to a pulley	DRB (K.4)
60140	Suction service valve	Valve to allow operations such as opening/closure or pressure measurement of the input refrigeration gas (low pressure)	VSU (K.4)
60150	Discharge service valve	Valve to allow operations such as opening/closure or pressure measurement of the output refrigeration gas (high pressure)	VDI (K.4)
60155	Discharge service valve cap	Cover for discharge service valve	VDC
60160	High-pressure cutout	Safety device to switch off the system in case of pressure above a fixed limit	CHP (K.4)
60170	Low-pressure cutout	Safety device to switch off the system in case of pressure below a fixed limit	CLP (K.4)
60175	Snubber	Device to smooth out refrigerant flow in compressor discharge line	SNB
60180	Oil cutout	Safety device to switch off the system in case of oil pressure below a fixed limit	CLO

Numerical code	Name	Description	CEDEX code
60190	Oil pump	Pump for distributing oil under pressure through the compressor to lubricate moving parts	PPO
60200	Oil sight glass	Sight glass for checking the oil level	SGO
60210	Oil sump gasket	Gasket seal between the oil sump and the compressor body	SGS (K.4)
60220	Oil charge	Quantity of oil	OCH (K.4)
60230	Others	Other compressor devices not listed	QMI (K.4)
60240	Reed (or ring valves)	Intake and exhaust valves for refrigerant flow through compressor cylinders	RRV
60245	Valve plate	Plate on cylinder with valves	PVA
60250	Motor	Motor assembly excluding the compressor items	MAS (K.4)
60260	Stator	Stationary winding part of the motor	STA (K.4)
60270	Rotor	Winding part of the motor that revolves in the stator	ROT (K.4)
60280	Collector	Conductor maintaining contact between the rotor and the stator	COL (K.4)
60290	Collector brush	Carbon electrical conductor that makes sliding contact on the collector	COB (K.4)
60300	Bearing	Part of the motor to support the revolving rotor in the centre of the stator (not specified elsewhere)	BNG (K.4)
60310	Terminal mounting plate	Board for making electrical connections on the compressor motor	TMP
60320	Overload protection switch	Safety device to switch off the system in case of overloading of the motor	POL
60330	Others (motor)	Other compressor-motor devices not listed	MIN (K.4)
60340	Fixing/securing device	Element fixing the compressor/motor assembly to the frame	FIX (K.4)
60350	Compression vibration damper	Device between compressor motor and frame to absorb vibrations	QDA

K.6.2 Condenser - Location: MKNN

60510	Coil assembly	Series of pipes connected in rows to increase heat exchange	CAS (K.4)
60515	Tube sheet distributor	Plate which holds individual tubes in position within coil	TSH
60516	Condenser coil mounting bracket	Bracket holding condenser coil in place	CCB
60520	Inlet distributor	Series of pipes through which the refrigeration gas enters the condenser	TIN
60530	Outlet collector	Series of pipes through which the refrigeration gas leaves the condenser	TOU

Numerical code	Name	Description	CEDEX code
60540	Bent tube (return tube)	Bent tubes to connect one row of pipes to another	TBE (K.4)
60550	Straight tube	Tube to allow refrigeration gas circulation through the fins of the condenser	TPI (K.4)
60555	Coil fins	Fins expediting heat transfer from tubes	CFI
60560	Motor	Motor assembly to revolve the fan	MAS (K.4)
60570	Stator	Stationary winding part of the motor	STA (K.4)
60580	Rotor	Winding part of the motor that revolves in the stator	ROT (K.4)
60590	Collector	Conductor maintaining contact between the rotor and the stator	COL (K.4)
60600	Collector brush	Carbon electrical conductor that makes sliding contact on the collector	COB (K.4)
60610	Bearings	Part of the motor to support the revolving rotor in the centre of the stator	BNG (K.4)
60620	Terminal mounting plate	Board for making electrical connections on the condenser motor	TMP
60630	Overload protection switch	Safety device to switch off the system in case of overload of the motor	POL
60640	Fixing/securing device	Element fixing the condenser/motor assembly to the frame	FIX (K.4)
60650	Fan	Assembly of blades to produce a flow of air through the coil	FAN
60680	Refrigerant inlet valve	Device for closing/opening the refrigerant inlet flow	VFI (K.4)
60690	Refrigerant outlet valve	Device for closing/opening the refrigerant outlet flow	VFO (K.4)
60700	Water-cooled condenser	Heat exchanger in which refrigerant is changed from gas to liquid by water cooling	CWA
60710	Water inlet valve	Device for closing/opening the water inlet flow in the water-cooled condenser	VWI (K.4)
60720	Water outlet valve	Device for closing/opening the water outlet flow in the water-cooled condenser	VWO (K.4)
60730	Others	Other condenser devices not listed	KMI (K.4)

K.6.3 Evaporator - Location: MVNN

60810	Coil assembly	Series of pipes connected in rows to increase heat exchange	CAS (K.4)
60820	Inlet tubing	Series of pipes through which the refrigerant enters the evaporator	TIN (K.4)
60830	Outlet tubing	Series of pipes through which the refrigerant leaves the evaporator	TOU (K.4)
60840	Bent tubes (return tube)	Bent tubes to connect one row of pipes to another	TBE (K.4)
60850	Straight tube	Tube to allow refrigeration gas circulation through the fins of the evaporator	TPI (K.4)

Numerical code	Name	Description	CEDEX code
60855	Coil fins	Fins expediting heat transfer from tubes	CFI
60856	Evaporator coil heaters	Electrical resistors for defrosting the evaporator or heating the inside of the container	HVC (K.6)
60857	Drain pan defrost heaters	Electrical resistors for defrosting the drain pan or heating the container	HDP (K.6)
60858	Overheat protection switch ["klixon"]	Device which switches off heaters in case of excessive temperature	KLX (K.6)
60859	Drain tube defrost heaters	Electrical resistors provided on the drain tube for defrosting	DTH (K.7)
60860	Motor	Motor assembly to revolve the fan	MAS (K.4)
60861	Drain port defrost heaters	Electrical resistors provided on the drain port for defrosting	DPH
60870	Stator	Stationary winding part of the motor	STA (K.4)
60880	Rotor	Winding part of the motor that revolves in the stator	ROT (K.4)
60890	Collector	Conductor maintaining contact between the rotor and the stator	COL (K.4)
60900	Collector brush	Carbon electrical conductor that makes sliding contact on the collector	COB (K.4)
60910	Bearings	Part of the motor to support the revolving rotor in the centre of the stator	BNG (K.4)
60920	Terminal mounting plate	Board for making electrical connections on the evaporator motor	TMP
60930	Overload protection switch	Safety device to switch off the system in case of overload of the motor	POL
60940	Fixing/securing device	Element fixing the evaporator/motor assembly to the frame	FIX (K.4)
60950	Fan	Assembly of blades to produce a flow of air through the coil	FAN (K.4)
60970	Others	Other evaporator devices not listed	VMI (K.4)

K.6.4 Electrical power - Location: MENN

61010	Electrical plug, 460 V	Device to connect the 460 V power cable to the power supply receptacle	EPL
61015	Electrical plug, 230 V	Device to connect the 230 V power cable to the power supply receptacle	EPE
61020	Cable, 460 V	Power line (460 V) to transmit electrical power to the refrigeration unit	ECB
61025	Cable, 230 V	Power line (230 V) to transmit electrical power to the refrigeration unit	ECC
61026	Cable indicator sleeve, 460 V	Identifying label on 460 V power cable	ECD

Numerical code	Name	Description	CEDEX code
61027	Cable indicator sleeve, 230 V	Identifying label on 230 V power cable	ECE
61030	On/off main switch	Manual device which connects and breaks the refrigeration unit electric circuit	SMN (K.5)
61040	Voltage selection switch	Device which allows voltage accepted by the unit to be adapted to the power supply available	SVS (K.5)
61045	Voltage selection switch knob	Knob for voltage selection switch	SVK
61046	Voltage selection switch door	Cover for voltage selection switch compartment	SVD
61047	Voltage selection switch door hinge	Hinge for cover for voltage selection switch compartment	SVH
61050	Circuit breaker, 460 V	Safety device which breaks the 460 V electric circuit if a fault develops	CBR
61055	Circuit breaker, 230 V	Safety device which breaks the 230 V electric circuit if a fault develops	CBB
61060	Power transformer	Apparatus which converts electrical voltage from the supply voltage to operating voltage	TFM
61070	Phase-reversal device	Device which reverses the electric current phase order in case of unsuitable phase order of the power supply	PRS (K.5)
61080	Power supply terminal plate	Electrical connections which receive the power supply directly from the mains	EPS (K.5)
61090	Compressor motor capacitor	Apparatus for accumulating electricity which allows the compressor motor to be started	CAQ
61100	Evaporator fan motor capacitor	Apparatus for accumulating electricity which allows the evaporator motor to be started	CAV
61110	Condenser fan motor capacitor	Apparatus for accumulating electricity which allows the condenser motor to be started	CAK
61120	Compressor contactor	Contacting device which connects or breaks the compressor electric circuit according to the control box order	CQA (K.5)
61130	Compressor low-speed contactor	Contacting device which connects or breaks the compressor low-speed electric circuit according to the control box order	CQL (K.5)
61140	Compressor high-speed contactor	Contacting device which connects or breaks the compressor high-speed electric circuit according to the control box order	CQH (K.5)
61150	Evaporator contactor	Contacting device which connects or breaks the evaporator electric circuit according to the control box order	CVL (K.5)
61160	Evaporator fan motor low-speed contactor	Contacting device which connects or breaks the evaporator low-speed electric circuit according to the control box order	CVL (K.5)
61170	Evaporator fan motor high-speed contactor	Contacting device which connects or breaks the evaporator high-speed electric circuit according to the control box order	CVH (K.5)

Numerical code	Name	Description	CEDEX code
61180	Condenser fan motor contactor	Contactors which connect or break the condenser electric circuit according to the control box order	CKA (K.5)
61190	Condenser fan motor low-speed contactor	Contactors which connect and break the condenser low-speed electric circuit according to the control box order	CKL (K.5)
61200	Condenser fan motor high-speed contactor	Contactors which connect or break the condenser high-speed electric circuit according to the control box order	CKH (K.5)
61210	Defrost/heating resistors contactor	Contactors which connect or break the heating resistor electric circuit according to the control box order	CHR (K.5)
61220	Phase contactor	Contactors which set up the phase order according to the phase reversal system	CPH (K.5)
61230	Terminal	Point where electrical/electronic components are connected	CON
61240	Wiring	System of wires between electrical components	WIR (K.5)
61250	Others	Other electrical power devices not listed	EMI (K.4)

K.6.5 Regulation/control - Location: MCNN

61410	Controller	Device which controls essential functions of the refrigeration unit, especially temperature	CTR (K.5)
61415	Microprocessor controller	Controller whose functions are governed by a microprocessor chip	CPU
61420	Mechanical temperature recorder	Complete assembly of device which records the inside temperature of the container	REC
61425	Recorder clock	Clock which advances the recorder chart	RCL
61426	Recorder mechanism	Mechanical device driving the stylus of temperature recorder	RCR
61430	Timer	Device which controls and sets up delays between the different functioning modes of the refrigeration unit	TIM (K.5)
61435	Recording chart	Paper record of return-air temperature during a time interval	RCH
61437	Recording chart battery	NOTE - Preliminary assignment; to be defined in a future edition	RCB
61440	Stylus	Point which records the temperature as a function of time	STY (K.5)
61441	Stylus lifter	Arm which engages and disengages stylus from contact with recording chart	STL
61445	Electronic recorder/data-logger	Device which records the operating conditions of the unit for retrieval by electronic means	ERD

Numerical code	Name	Description	CEDEX code
61450	Thermostat	Device which regulates the container inside temperature according to the set-point temperature	TMT (K.5)
61460	Record sensor probe	Apparatus which indicates the container temperature to the recorder	SRE (K.5)
61470	Control sensor (return air)	Apparatus which indicates the temperature of the return-air to the controller	SRA
61480	Control sensor (supply air)	Apparatus which indicates the temperature of the supply air to the controller	SSA
61490	Hourmeter	Clock which records the compressor running hours	HMT
61500	Thermistor ("Simpson") sensor	Apparatus which indicates the temperature to the thermometer jack	SSY
61510	Thermistor ("Simpson") jack	Receptacle where the temperature meter can be connected	SYJ
61520	Electronic recorder sensor (return air)	Sensor which indicates the temperature to the recorder return channel	SER
61523	Electronic recorder sensor (supply air)	Sensor which indicates the temperature to the recorder supply channel	SES
61524	Defrost timer	Clock which controls the time interval between two defrostings	TDF (K.6)
61525	Manual defrost	Manual device which allows the defrosting to start	SMD (K.6)
61526	Defrost termination switch	Device which switches off the defrosting of the evaporator	SDT (K.6)
61527	Evaporation coil defrost temperature sensor	Device which controls the defrost cycle by sensing temperature	EVS
61528	Air pressure switch	Device to detect pressure difference across evaporator coil for defrost initiation	APS (K.6)
61530	Defrost relay	Relay which controls the defrosting of the evaporator coil	RDE (K.5)
61535	Defrost interval selector switch	Switch to select choice of defrost intervals	DIS
61536	Defrost interval selector switch knob	Knob fitted to shaft of defrost interval selector switch	DIK
61540	Phase-reversal relay	Relay energizing either of two electrical phase contactors	RPR
61550	Timer relay	Relay which controls the start-up of the electric components of the refrigeration unit	RTM (K.5)
61560	Heating relay	Relay which operates the heating resistors	RHR (K.5)

Numerical code	Name	Description	CEDEX code
61570	In-range relay	Relay which operates the "in-range" light when the container is in the correct temperature range	RIR (K.5)
61580	Cooling relay	Relay which operates the "cooling" light when the compressor is working	RFC (K.5)
61590	Unloading relay	Relay which operates the unloading of the compressor cylinders when the container has reached the set-point temperature	RCU (K.5)
61600	Compressor cooling relay (quench)	Relay which operates the quench valve	RQQ
61610	Compressor overload relay	Relay which switches off the compressor motor in case of overload	ROL (K.5)
61620	Partial cool relay	Relay which operates the "partial cool" light when the compressor is working at reduced power (temperature close to the set-point)	RPC (K.5)
61630	Mother electronic board	Main electronic board which is connected to all the other electronic boards	BMN (K.5)
61640	Control electronic board	Electronic board which manages all the controller functions	BCT (K.5)
61650	Phase reversal electronic board	Electronic board which controls the reversal of the phase sequence	BPR (K.5)
61660	Power + supply in range electronic board	Electronic board which controls the power supply and the temperature inside the container	BMS (K.5)
61670	Timing + current control electronic board	Electronic board which controls the motor starting sequence and the electric current of the modulating valves	BCC (K.5)
61680	Temperature control electronic board	Electronic board which controls the temperature inside the container	BTC (K.5)
61690	Relay electronic board	Electronic board to which all the various relays are connected	BRY (K.5)
61700	Amplifier electronic board	Electronic board which amplifies the data coming from the various sensors	BAM (K.5)
61710	Temperature display	Device which displays the temperature of the supply or return air	TDI (K.5)
61715	Temperature simulator switch	Switch to mimic different temperature to control than actual one	TSS
61720	Transformer, control circuit	Apparatus which converts electrical voltage from the supply voltage to that required in the control circuit	TRF
61730	Fuse	Short piece of wire which melts and breaks the control circuit if a fault develops in it	FUS (K.5)
61735	Fuse holder	Retainer for fuses	FHD
61740	Monitor lights	Device which indicates the running condition of the refrigeration unit	LIT (K.5)

Numerical code	Name	Description	CEDEX code
61750	Remote monitoring plug	Device which allows the motor start-up sequence to be cancelled	SOR (K.5)
61755	Remote monitoring receptacle cap and chain	Cover and retainer for remote-monitoring receptacle	MRC
61760	Remote monitoring plug	Device to connect the remote-monitoring device	MRP (K.5)
61765	Condenser pressure switch	Device which operates the condenser fans according to the discharge pressure of the compressor	SPK (K.6)
61766	Water-cooled condenser pressure switch	Device which switches off the condenser fans when the water-cooled condenser is connected	SPW (K.6)
61770	Override delay switch	Device which allows the motor start-up sequence to be cancelled	SOR (K.5)
61775	Regulation terminals	Connection points for regulation electrical components	CRE
61780	Connections	Points where electric/electronic components are connected	CON (K.5)
61790	Operation test (toggle) switch	Device which allows simulation of a temperature different from the set-point in order to test the refrigeration unit	TSW (K.5)
61795	Set-point selector (digital)	Digital selection switch(es) to set the required temperature to be maintained	SPS
61796	Dial set-point thermostat	Rheostat (including knob) to set the required temperature to be maintained	THE
61800	Others	Other regulation/control devices not listed	CMI (K.4)

K.6.6 "Defrost/heating" is deleted

K.6.7 Piping - Location: MPNN

62010	Quench valve	Device which allows refrigeration of the compressor during the partial cool sequence and/or when the suction modulating valve is nearly closed	VQA (K.6)
62020	Quench valve body	Mechanical structure of the quench valve	VQB (K.6)
62030	Quench valve solenoid	Solenoid coil which operates the quench valve solenoid	VQS (K.6)
62040	Suction-modulating valve	Device which allows suction modulation of the compressor during the partial control	VMA (K.6)
62050	Modulating valve body	Mechanical structure of the modulating valve	VMB (K.6)
62060	Modulating valve solenoid	Solenoid coil which operates the modulating valve	VMS (K.6)

Numerical code	Name	Description	CEDEX code
62070	Suction solenoid valve	Device which is opened when the temperature inside the container is far from the set point and closed when it is close to it (partial cool)	VSA (K.6)
62080	Suction solenoid body	Mechanical structure of the suction valve	VSB (K.6)
62090	Suction valve solenoid	Solenoid which operates the suction valve	VSS (K.6)
62100	Hot-gas modulating valve	Device which allows evaporator defrosting and/or temperature control by injection of hot refrigerant into the suction-gas line	VGA
62110	Hot-gas modulating valve body	Mechanical structure of the hot-gas modulating valve	VGB (K.6)
62120	Hot-gas modulating valve solenoid	Solenoid which operates the hot-gas modulating valve	VGS (K.6)
62130	Expansion valve	Device which allows expansion of the refrigerant into the evaporator and regulates the super-heat of the gas from the evaporator	VEX (K.6)
62140	Feeler bulb	Sensor which indicates the temperature of the gas leaving the evaporator to the expansion valve	BOH (K.6)
62145	Pressure regulator	Device to control pressure out of the compressor	PRG
62147	Throttling valve	Device metering the flow of refrigerant for temperature control	VTH
62150	Heat exchanger	Device which allows exchange of heat between hot gas and cold liquid in order to increase the efficiency of the refrigeration system	HEX (K.6)
61260	Suction-line insulation	Material which prevents heat transfer in the suction line	ISL (K.6)
62170	Liquid-line service valve	Device which regulates the liquid flow from the condenser	VLL (K.6)
62180	Moisture indicator	Device which indicates if there is moisture in the refrigerant charge	SGI (K.6)
62190	Drier filter	Device which allows the refrigerant charge to be dried	DRF (K.6)
62200	Safety valve-fusible plug	Device which opens the piping circuit in case of over-pressure	FUP
62210	Discharge pressure gauge	Device which indicates the discharge pressure of the compressor	GDI (K.6)
62220	Suction pressure gauge	Device which indicates the suction pressure of the compressor	GSU (K.6)
62250	Refrigerant receiver	Tank in which condensed refrigerant may be stored	KWT
62255	Sight glass	Window for checking the refrigerant level	SGL

Numerical code	Name	Description	CEDEX code
62260	Vibrabsorber	Flexible pipes on the suction and discharge lines of the refrigeration unit which absorb vibrations	VIB (K.6)
62265	Accumulator	Storage chamber for liquid refrigerant in the suction line	ACC
62270	Refrigerant charge	Volume of refrigerant inside the refrigeration unit	FCH
62280	Others	Other piping devices not listed	PMI (K.4)

K.6.8 Frame - Location: MFNN

62510	Frame assembly	Structure of the refrigeration unit	FAS (K.7)
62520	Evaporator access panel	Panel which can be removed to access the evaporator section from outside the container	VAP (K.7)
62525	Heater access panel	Panel which can be removed to access the heater coils and drain section from outside the container	HAP
62530	Condenser grille	Device which protects the condenser fan outside the container	GLK (K.7)
62540	Compressor protection enclosure/ provision cable	Device which protects the compressor from shocks and allows to stow the power supply cable	QPG (K.7)
62550	Evaporator grille	Device which protects the evaporator fan inside the container	GLI (K.7)
62560	Inner panel	Front inside panel of the container	INP (K.7)
62570	Compressor base	Plate to which the compressor is fixed	QBS (K.7)
62580	Hardware	Screws, nuts, and bolts	HWR (K.7)
62590	Frame gaskets	Seals between the refrigeration unit frame and the container frame	GAS (K.7)
62600	Thermometer insertion port	Frame opening designed to insert a thermometer (either in the return air or the supply air)	TTU (K.7)
62610	Drain pan	Device fixed underneath the evaporator coil to collect defrost water	DPA (K.7)
62620	Drain tube	Tube which drains water out of the unit	DRN (K.7)
62630	Air exchange vent	Device which allows air renewal to reduce the concentration of gas given off by respiration cargo	ARE
62640	Electrical box	Box which contains all the electrical components for power control and recorder	BEA (K.7)
62650	Electrical door	Opening panel of the electrical box	BED (K.7)
62660	Electrical door gasket	Seal designed to close the electrical box door tightly to keep water out	BEG (K.7)
62664	Electrical door hinge	Hinge supporting electrical control box	BEH

Numerical code	Name	Description	CEDEX code
62665	Electrical diagram	Schematic or functional diagram of wiring	EDX
62666	Electrical diagram holder	Retainer for electrical diagram	EDH
62670	Controller box	Box which contains all the electric and electronic equipment components of the controller	BCA (K.7)
62680	Controller box door	Opening panel of the controller box	BCD (K.7)
62690	Controller box door gasket	Seal designed to close the controller box door tightly	BCG (K.7)
62695	Controller box door hinge	Hinge supporting controller box door	BCH
62696	Controller box door window	Glass mounted in controller box door	BCW
62700	Recorder box	Box which contains the temperature recorder	BRA (K.7)
62710	Recorder box door	Opening panel of the recorder box	BRD (K.7)
62720	Recorder box door gasket	Seal designed to close the recorder box tightly	BRG (K.7)
62725	Recorder box door window	Glass mounted in recorder box door	BRL
62726	Recorder box door hinge	Hinge supporting recorder box door	BRH
62730	Recorder key/chain	Key, designed to wind up the recorder clock, and the chain fastening this key to the box	RKY (K.7)
62735	Recorder chart nut/chain	Fastener and retainer for recorder chart	RCC
62736	Recorder key holder	Retainer for recorder winding key	RKC
62737	Expansion valve door hinge	Hinge support for expansion valve cover	TXH
62738	Electrical component shield	Cover to guard against accidental contact with high-voltage circuits	BES
62740	CO ₂ sampling plug	Device which allows sampling of air from the container to measure the concentration of carbon dioxide	COO (K.7)
62745	Document holder	Pocket or tube to carry documents	MDH
62750	Markings	Printed information or warnings on the refrigeration unit	MRK (K.7)
62760	Clamping device, upper	Device for attaching a clip-on refrigeration unit to the upper receptacle of a container	HCU

Numerical code	Name	Description	CEDEX code
62770	Clamping device, lower	Device for attaching a clip-on refrigeration unit to the lower receptacle of a container	HCL
62780	Others	Other frame devices not listed	FMI (K.4)
K.6.9 Miscellaneous - Location: MZNN			
62800	Air filter, primary	Primary device for screening air flow	AFP
62810	Air filter, secondary	Secondary device for screening air flow	AFS
62820	Controlled-atmosphere compressor	Compressor in controlled-atmosphere system	CAR
62830	Controlled-atmosphere drier	Drier in controlled-atmosphere system	CAD
62840	Controlled-atmosphere heater	Heater in controlled-atmosphere system	CAH
62850	Oxygen/nitrogen separator	Membrane for separating flows of oxygen and nitrogen gases	ONS
62860	Oxygen/nitrogen valve	Flow regulator for oxygen and nitrogen gas lines	ONV
62870	Carbon dioxide supply	Tank containing carbon dioxide gas	CDY
62880	Controlled-atmosphere controller	Electronic device for regulation of controlled-atmosphere system	CAC
62890	Sensor, oxygen	Device to detect oxygen in controlled-atmosphere system	OXS
62900	Sensor, carbon dioxide	Device to detect carbon dioxide in controlled-atmosphere system	CDS
62910	Sensor, water	Device to detect water in controlled-atmosphere system	SRW
62920	Sensor, temperature	Device to detect temperature changes in controlled-atmosphere system	SRT
62930	Humidity control	Apparatus for controlling humidifier	HUC
62940	Humidifier	Apparatus for keeping the humidity in a container within limits	HUM
62950	Water tank	Storage receptacle for water	WTK
62960	Ethylene scrubber	Filter to remove ethylene gas	ETS
62970	Carbon dioxide scrubber	Filter to remove carbon dioxide gas	CDR

Numerical code	Name	Description	CEDEX code
62980	Controlled-atmosphere door switch	Switch to shut down operation of refrigeration and controlled-atmosphere unit when container door is opened	CAW

K.7 Components of tank containers

K.7.1 Frame - Location: AFNN

70010	Frame fasteners	Bolts and nuts used to secure framework and/or walkways	YFF
70020	Frame strap	Band to secure pressure vessel to frame	YFS
70030	Frame strap mounting pad	Welded bracket to connect straps to frame	YMP
70040	Diagonal brace	Diagonal structural member	YDR
70050	Saddle	Structure to support pressure vessel within frame	YSA
70060	Skirt	Structure to connect pressure vessel to end frames	YSK
70070	Vertical post	Vertical structural member	YVP
70080	Frame gussets/stiffeners	Miscellaneous structural brackets	YTG
70090	Load transfer area	Cross-member or pad to allow proper interface with transportation means	YLT
70100	Horizontal rail	Horizontal structural member	YHR

K.7.2 Pressure vessel - Location: APNN

70200	Welded flange	Steel ring welded to pressure vessel to accept bolted accessories	YFL
70210	Sump	Depression located at the bottom of pressure vessel to facilitate discharge	YSU
70220	Shell	Cylindrical body of a pressure vessel	YSH
70230	Vapour flange	Orifice giving access to vapour phase of tank contents	YUF
70240	Stiffening ring	Reinforcing circumferential ring externally welded to pressure vessel	YST
70250	Head	Dished end of pressure vessel	YHE
70260	Baffle	Vertical plate to reduce surge	YBA
70270	Baffle holder	Fitting for removable baffle	YBH

K.7.3 Loading/unloading components - Location: ALNN

70300	Level indicator	Indicator showing whether tank is level with ground	YLN
70310	Coupling	Connection of tank to external piping	YCO

Numerical code	Name	Description	CEDEX code
70320	Diptube	Tube to allow pressure discharge through top outlet	YDI
70330	Top external valve assembly	External loading and unloading valve at tank top	YEU
70340	Foot valve gasket	Gasket between tank and foot valve	YGA
70350	Foot valve assembly	First internal bottom closure	YFV
70360	External valve assembly	Second bottom closure	YEV
70370	Air valve	Valve used to vent or pressurize	YAV
70380	Blind flange	Bolted closing plate	YBF
70390	Sample valve assembly	Valve used to sample product from the tank	YTV
70400	Spacer	Device used to position a clamped valve between flanges	YPV

K.7.4 Manhole - Location: AMNN

70500	Manhole cover (manlid)	Steel lid that covers the manhole	YMC
70510	Manhole flange	Steel collar upon which the manhole cover closes	YMF
70520	Manlid hold-down fasteners	Securing device for closing manlid	YHD
70530	Manlid hinges	Fitting by which manhole cover rotates	YMO
70540	Manhole assembly	Manhole with complete set of components, including manlid and flange	YMH
70550	Manlid gasket	Manlid sealing gasket	YMG
70560	Manhole dipstick	Calibrated bar to measure filling level	YMD
70570	Manhole dipstick holder	Retaining fitting for manhole dipstick	YMR

K.7.5 Insulation - Location: AINN

70600	Insulation material	Material used to reduce heat transfer	YIN
70610	Insulation cladding	Protection for insulation	YIC
70620	Sun shield	Thermal protection mounted on top of tank	YSN
70630	Sun shield support	Bracket welded on tank used to fix sun shield	YTS
70640	Cladding strap	Outside belt with tensioning device	YCS

Numerical code	Name	Description	CEDEX code
70650	Cladding support	Bracket welded on tank, used to fix cladding and secure insulation	YCD
K.7.6 Heating - Location: AHNN			
70700	Steam inlet/outlet	Steam supply connection	YSI
70710	Steam safety valve	Steam over-pressure relief valve	YSV
70720	Steam heating tubes	Steam circulation tubes	YSE
70730	Steam line cap	Steam line closure system	YSL
70740	Electrical heating element	Device which produces heat by electrical resistance	YEH
70750	Steam trap	Device for removal of condensate from steam circulation system	YDV
70760	Thermometer receptacle	Fitting to allow insertion of temperature probe	YTW
70770	Thermometer	Temperature-measuring device	YTM
K.7.7 Safety devices - Location: ASNN			
70800	Safety relief valve manometer	Pressure gauge used to check integrity of rupture disk	YRM
70810	Safety relief valve	Device used to avoid over-pressure of vessel	YTR
70820	Safety relief flange	Steel collar for connection to pressure vessel	YSR
70830	Rupture disk	Frangible disk used in conjunction with relief valve	YRU
70840	Safety relief valve flame trap	Metal gauze to prevent flashback	YFT
70850	Earth (ground) connection	Electrical protection to earth (ground)	YEC
70860	Gas tank internal safety valve	Valve which closes if coupling is broken	YIS
70870	Gas tank excess flow valve	Restriction to limit the flow of gas	YEX
70880	Rupture disk holder	Flange which holds rupture disk	YRD
70890	Emergency closure remote control	Remote trip device to allow closing of internal valve	YEM
70900	Overheating fusible link	Temperature-sensitive emergency closure system	YOH

Numerical code	Name	Description	CEDEX code
K.7.8 Markings - Location: ADNN			
71000	Operator marking	Marking required by operator	YOM
71010	FRA marking	Marking required by US Federal Railroad Administration	YFR
71020	Tank data plate	Metal plate containing data applicable to tank and contents	YTA
71030	CTC marking	Marking required by Canadian Transport Commission	YCT
71040	DOT marking	Marking required by US Department of Transportation	YDO
71050	FLA plate	Metal plate required by Japanese fire marshal	YFU
71060	Electrical wiring marking	Marking showing routing or schematic of electrical wiring	YEW
71070	Earth (ground) connection marking	Marking showing location of earth (ground) connection	YEA
71080	Product marking	Marking indicating contents of tank	YPM
71090	RTMD marking	Marking required by France for transport of hazardous cargo	YRT
71100	AAR marking	Marking required by Association of American Railroads	YAA
71110	BAM marking	Marking required by Germany for transport of hazardous cargo	YBM
71120	UIC marking	Marking required by Union International de Chemin de Fer (International Railway Union)	YUI
71130	RID/ADR marking	Marking required by European Union	YRI
K.7.9 Access - Location: AANN			
71200	Walkway	Grid floor on top of tank used for walking	YWA
71210	Walkway fitting	Hardware used to secure the walkway	YWF
71220	Hand rail assembly	Assembly including bar used by personnel for balance and support	YHA
71230	Ladder	Device used by personnel for climbing and descending	YLA
71240	Ladder grip handle	Grip for handling ladder	YLG
71250	Manometer step guard	Impact protection for manometer	YMS
K.7.10 Spill box - Location: ABNN			
71300	Spill box	Casing surrounding top fittings to catch overflow	YSP

Numerical code	Name	Description	CEDEX code
71310	Spill box cover	Lid of spill box	YBC
71320	Spill box lid hinge	Fitting by which lid rotates	YSB
71330	Spill box lock assembly	Fitting to allow sealing of spill box	YLO
71340	Tank draining tube	Drainpipe connected to spill box	YDT

K.7.11 Miscellaneous - Location: AZNN

71400	Customs seal point	Hole at various closures to allow customs or other sealing	YCU
71410	Washing nozzle	Spray device fitted on pressure vessel for washing	YWN
71420	Calibration chart	Conversion table for dipstick graduations	YCC
71430	Document holder	Pocket or tube to carry documents	YDH
71440	Service manometer	Manometer to indicate internal pressure of tank	YMA
71450	Product plate holder	Holder for placard displaying product identification	YPP
71460	Tank lining	Chemically resistant internal coating of pressure vessel	YLI

K.8 Components of generator sets and engines

K.8.1 Engine - Location: GDNN

80000	Engine assembly	Entire engine	JNA
80010	Bearing and rod assembly	Connecting rod and associated bearing	JNR
80020	Crankshaft	Rotating member that transmits torque to generator	JNV
80030	Crankshaft bearings	Bearings forming part of crankshaft	JNJ
80040	Gasket, cylinder block front cover	Seal on cylinder block front cover	JGF
80050	Gasket, cylinder head cover	Seal on cylinder head cover	JGC
80060	Gasket, cylinder head	Seal on cylinder head	JGH
80070	Engine cylinder head	Top portion of engine cylinders	JNH
80080	Engine exhaust manifold	Exhaust piping attached directly to cylinder head	JNQ

Numerical code	Name	Description	CEDEX code
80090	Engine belt	Drive belt for any engine pulley	JNE
80100	Engine bearing	Miscellaneous bearing within engine, not otherwise defined	JNB
80110	Engine fan	Cooling fan for engine	JNF
80120	Engine bowl strainer	Fuel strainer in engine bowl	JNS
80130	Engine assembly	Complete engine	JNA
80140	Engine air cleaner	Filter for air entering engine combustion chamber	JND
80150	Engine cylinder head cover	Cover enclosing cylinder head components	JNC
80160	Engine exhaust elbow	Bent piping within exhaust line	JNX
80170	Gasket, exhaust manifold	Seal on exhaust manifold	JGE
80180	Idler pulley	Pulley not driving another component, used for tensioning drive belt	JNY
80190	Idler	Mounting for idler pulley	JNI
80200	Gasket, intake manifold	Seal on intake manifold	JGI
80210	Muffler/ silencer	Noise-abatement device fitted in exhaust line	JNM
80220	Piping	Miscellaneous engine piping not otherwise defined	JDP
80230	Piston assembly	Piston and connecting rod, including pin	JNP
80240	Radiator hose	Hose used to transport coolant to/from radiator	JJH
80250	Radiator assembly	Complete radiator and associated fittings	JJR
80260	Radiator shock absorber	Cushioning device for radiator	JJS
80270	Radiator cap	Cover for coolant intake port on radiator	JJF
80280	Rain cap	Cover on exhaust pipe for preventing entry of water from atmosphere	JNZ
80290	Thermostat	Coolant flow regulator based on coolant temperature	JKD

K.8.2 Electrical system - Location: GENN

80400	Alternator diode, negative	Negative terminal of diode	JMN
80410	Alternator exciter field	Exciter field within alternator	JME

Numerical code	Name	Description	CEDEX code
80420	Alternator diode, positive	Positive terminal of diode	JMP
80430	Ammeter	Current measurement device	JEN
80440	Battery charger plug	Male connector on charger	JEF
80450	Battery charger receptacle	Female connector on charger	JEB
80460	Battery	Self-contained power storage device	JEO
80470	Battery clamps	Securing fasteners for battery	JEJ
80480	Battery hold-down	Restraining bar holding battery in place	JED
80490	Circuit breaker, 12 V	Electrical safety device for 12 V circuit	JBD
80500	Circuit breaker, 230 V	Electrical safety device for 190/230 V circuit	JBC
80510	Circuit breaker, 460 V	Electrical safety device for 380/460 V circuit	JBA
80520	Circuit board	Board incorporating printed circuits and related electronic components	JBB
80530	Control box, main	Enclosure for main control circuits	JAB
80540	Exciter voltmeter	Electrical potential measurement device for exciter	JXM
80550	Exciter cover gasket	Seal for exciter cover	JEE
80560	Exciter assembly	Entire set of exciter components	JXA
80570	Exciter box	Enclosure for exciter	JXB
80580	Exciter rectifier, 3-phase	Converter of 3-phase a.c. to d.c.	JXP
80590	Exciter socket	Receptacle into which exciter is plugged	JXS
80600	Exciter cover	Cover for exciter assembly	JXC
80610	Exciter resistor	Resistive component within exciter	JXR
80620	Exciter rectifier diode	Diode component of exciter rectifier	JXE
80630	Glow plugs	Electrical component to bring fuel to combustion temperature	JEG
80640	Hourmeter	Device for measuring operating time of engine	JEH
80650	Receptacle, 230 V	Female connector for 190/230 V circuit	JET
80660	Receptacle, 460 V	Female connector for 380/460 V circuit	JEU
80670	Regulator	Voltage control device	JER

Numerical code	Name	Description	CEDEX code
80680	Run control relay	Electrical switching device to control engine operation	JRR
80690	Starter motor	Motor used to operate engine until ignition occurs	JES
80700	Starter motor solenoid	Induction coil within starter motor	JEM
80710	Switch, water high-temperature	Safety shutdown switch when water temperature is too high	JST
80720	Switch, high-temperature cutout	Safety shutdown switch when operating temperature is too high	JSH
80730	Switch, low oil pressure	Safety shutdown switch when oil pressure is insufficient	JSL
80740	Switch, on/off	Switch to start and stop engine operation	JSO
80750	Switch, on/off starter motor	Switch to engage starter motor	JSS
80760	Switch, preheat start	Switch to energize glow plugs	JSP
80770	Wiring, general	Wiring or harnesses not otherwise defined	JEY

K.8.3 Frame - Location: GFNN

80800	Cover	Weather-protective enclosure	JAC
80810	Door	Opening access cover	JAD
80820	Forklift pocket	Receptacle for forklift truck blade, used in lifting	JAF
80830	Frame assembly	Entire frame structure of generator set	JAA
80840	Mounting pin	Male frame securement fitting	JAL
80850	Mounting clamp	Frame securement fitting that secures by pressure	JAU
80860	Panel	Flat metal enclosure	JAP

K.8.4 Alternator - Location: GLNN

80900	Alternator assembly	Alternator and related components	JMA
80910	Alternator bearing	Lubrication fitting for alternator rotor	JMB
80920	Alternator disc rotor drive	Driving element of alternator rotor	JMD
80930	Alternator rotor	Movable electrical induction coil	JMR
80940	Alternator stator	Fixed electrical induction coil	JMS

Numerical code	Name	Description	CEDEX code
80950	Alternator	Generator of alternating current	JEL
K.8.5 Oil system - Location: GONN			
81000	Oil	Lubricating fluid	JOO
81010	Oil pan gasket	Seal on oil pan	JGO
81020	Oil temperature gauge	Measurement device for oil temperature	JOT
81030	Oil pan	Sump in which oil collects	JNU
81040	Oil level gauge	Indicator of depth of oil in pan	JOG
81050	Oil filter	Device for cleansing oil	JNL
81060	Oil pressure gauge	Device for oil pressure measurement	JNG
81070	Oil hose	Flexible conduit for oil	JDO
K.8.6 Fuel system - Location: GUNN			
81100	Antifreeze (fuel)	Fluid used to prevent freezing of fuel	JOF
81110	Diesel fuel	(Self-explanatory)	JOD
81120	Engine fuel strainer	Filter to remove impurities within engine	JFR
81130	Fuel gauge	Device for measuring amount of fuel in tank	JFG
81140	Fuel heater	Element to raise fuel to a temperature at which flow can occur	JFH
81150	Fuel hose	Flexible conduit for fuel flow	JDD
81160	Fuel tank	Receptacle for fuel	JFT
81170	Fuel hand pump	Manually operated device for forcing fuel flow	JFP
81180	Fuel filter	Filter to remove impurities in fuel line	JFF
81190	Fuel filter, secondary	Filter downstream of fuel filter	JFS
81200	Injection pump	Device to transport fuel to fuel injectors	JFI
81210	Injection nozzle	Orifice through which fuel is introduced into cylinders	JFO
K.8.7 Water system - Location: GWNN			
81300	Antifreeze (coolant)	Fluid used to prevent freezing of coolant	JWF

Numerical code	Name	Description	CEDEX code
81310	Water hose	Flexible conduit for flow of coolant	JDB
81320	Water pump, alternate	Pump used when main water pump is not used	JWA
81330	Water pump "O"-ring	Rubber sealant in water pump	JGW
81340	Water temperature sensor	Switch for sensing water temperature	JEK
81350	Water	Coolant fluid	JWW
81360	Water separator	Filter for removing water from fuel line	JWS
81370	Water pump	Device for regulating flow of coolant	JWP
81380	Water temperature gauge	Device for measuring coolant temperature	JWK

K.8.8 Entire generator set unit - Location: GXNN

81400	Generator set, complete	Entire generator set, including all components	JXX
-------	-------------------------	--	-----

K.8.9 Miscellaneous generator set components - Location: GZNN

81500	Clamps	Securing device operated by pressure	JIC
81510	Fasteners	Hardware securement fittings	JIF
81520	Hardware	Miscellaneous fasteners and routing fittings	JAH
81530	Markings	Decals and plates conveying information	JAM
81540	Other components	Components of generator sets not specified elsewhere	JAO

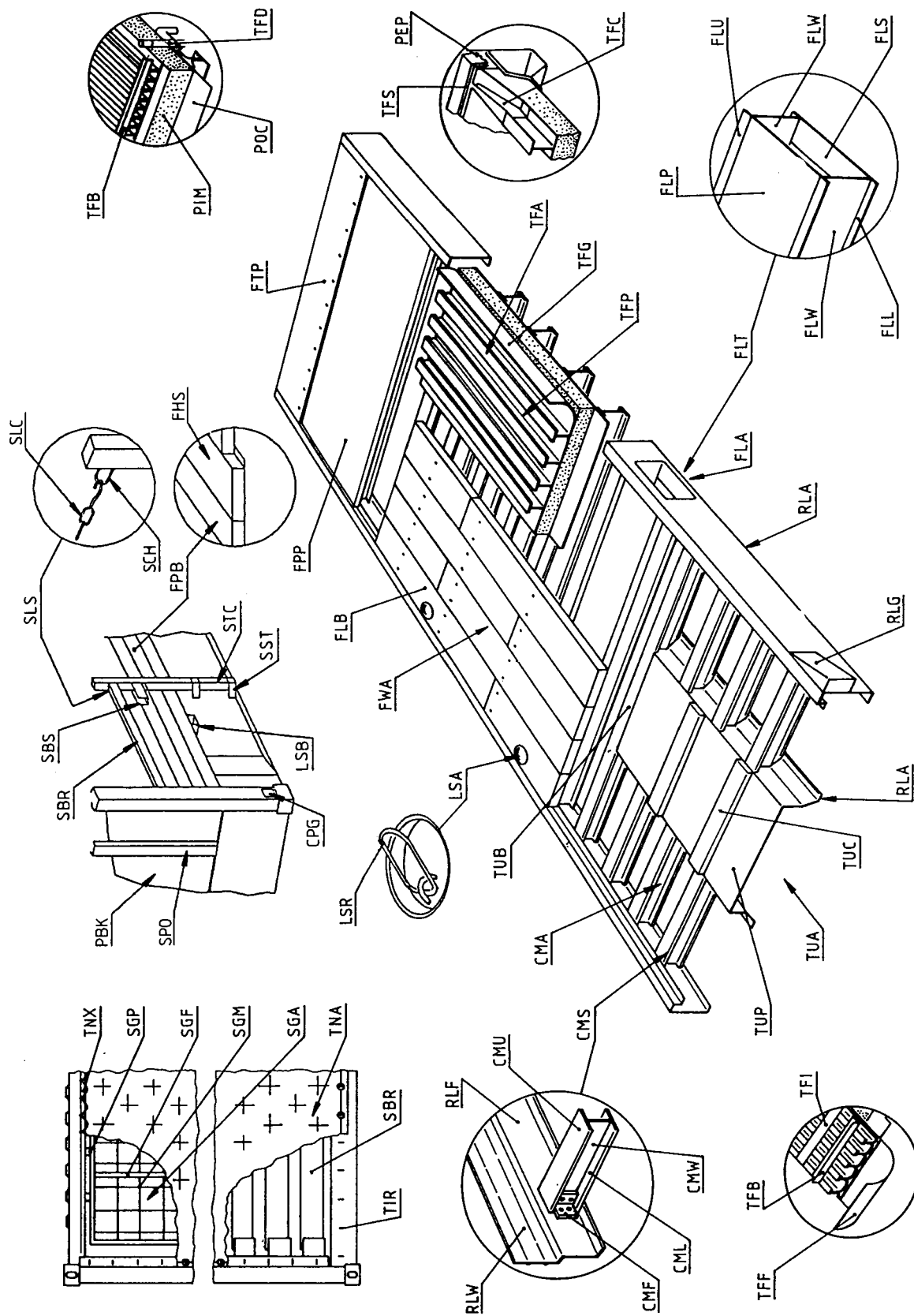

Figure K.1

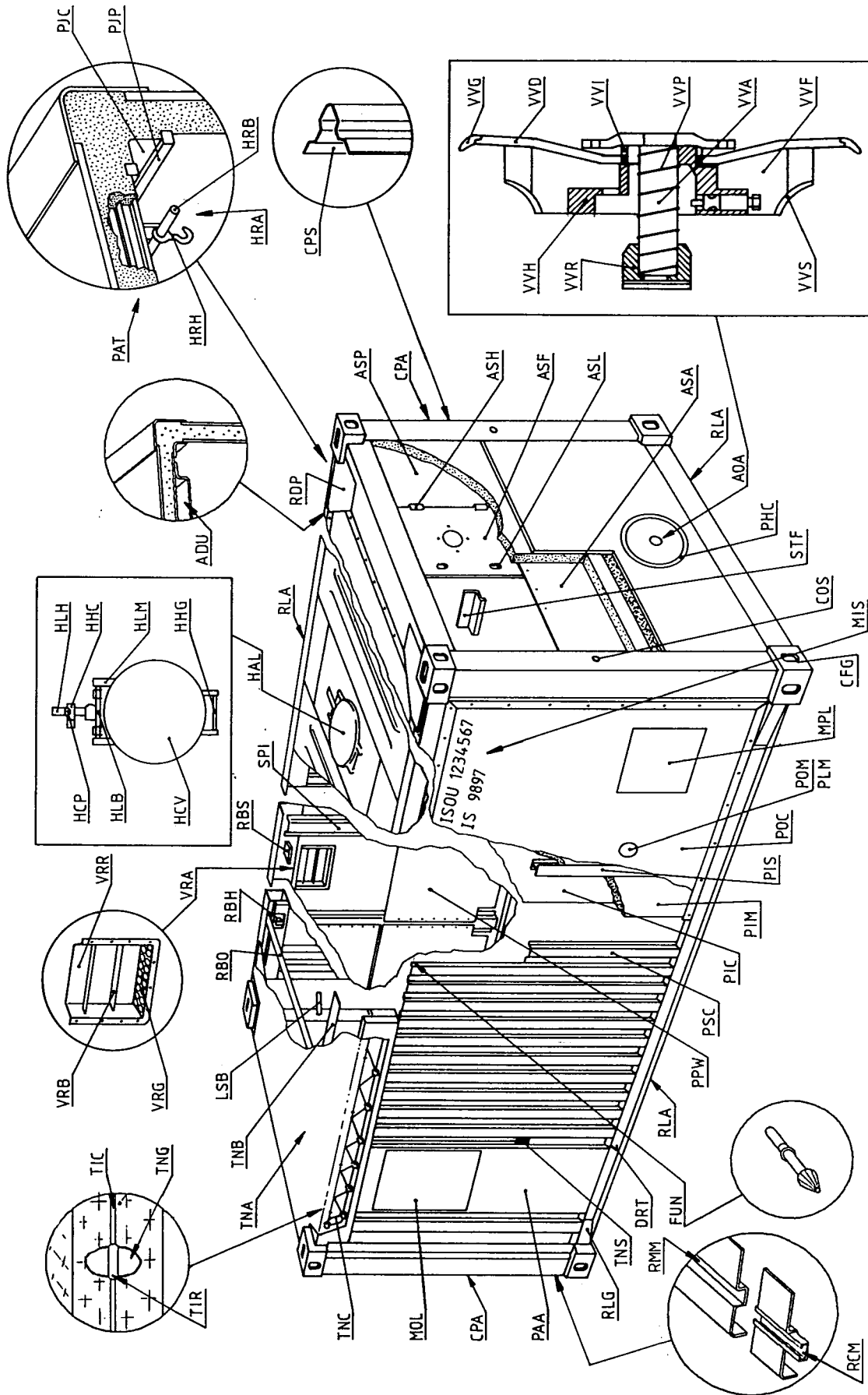

Figure K.2

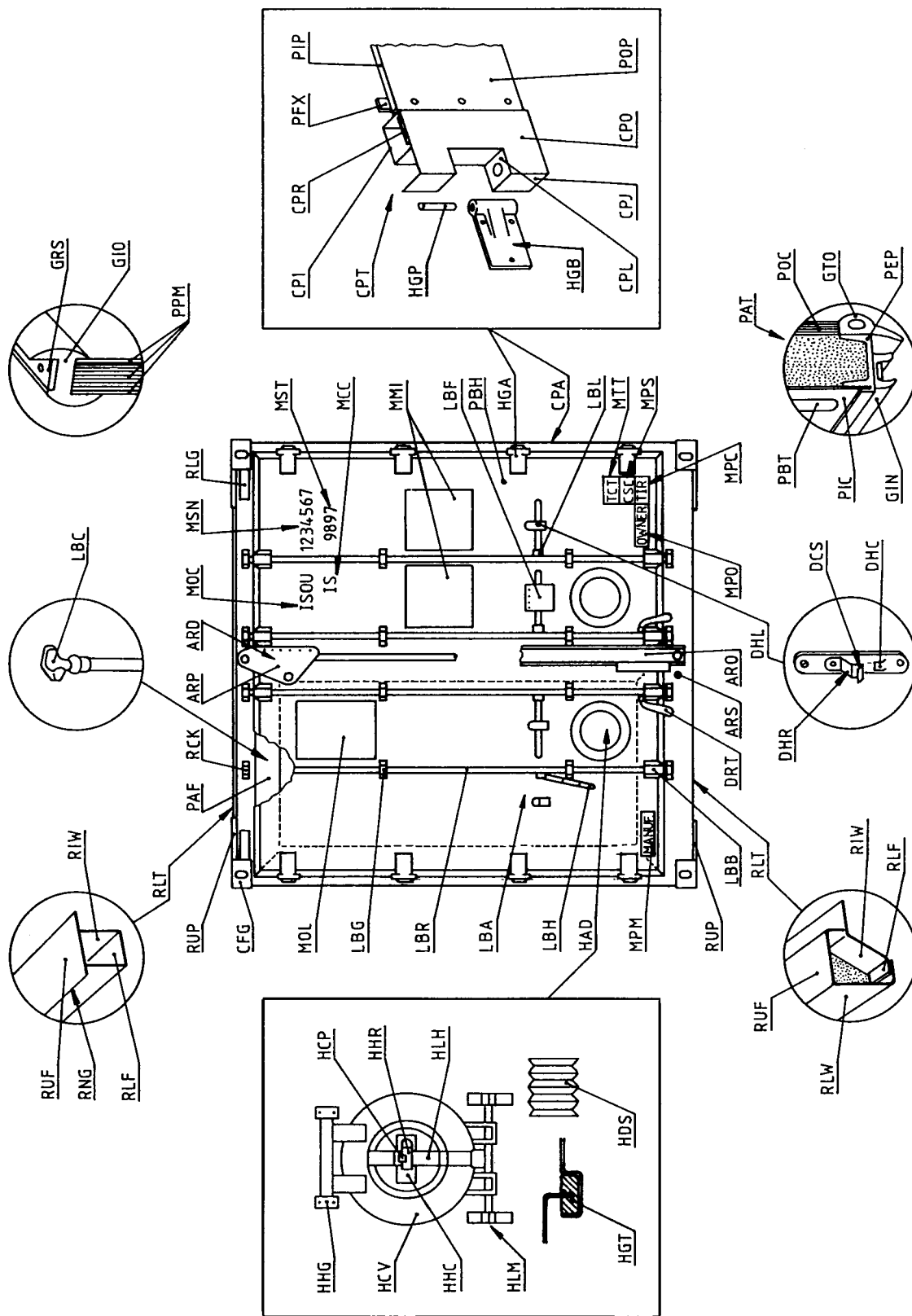

Figure K.3

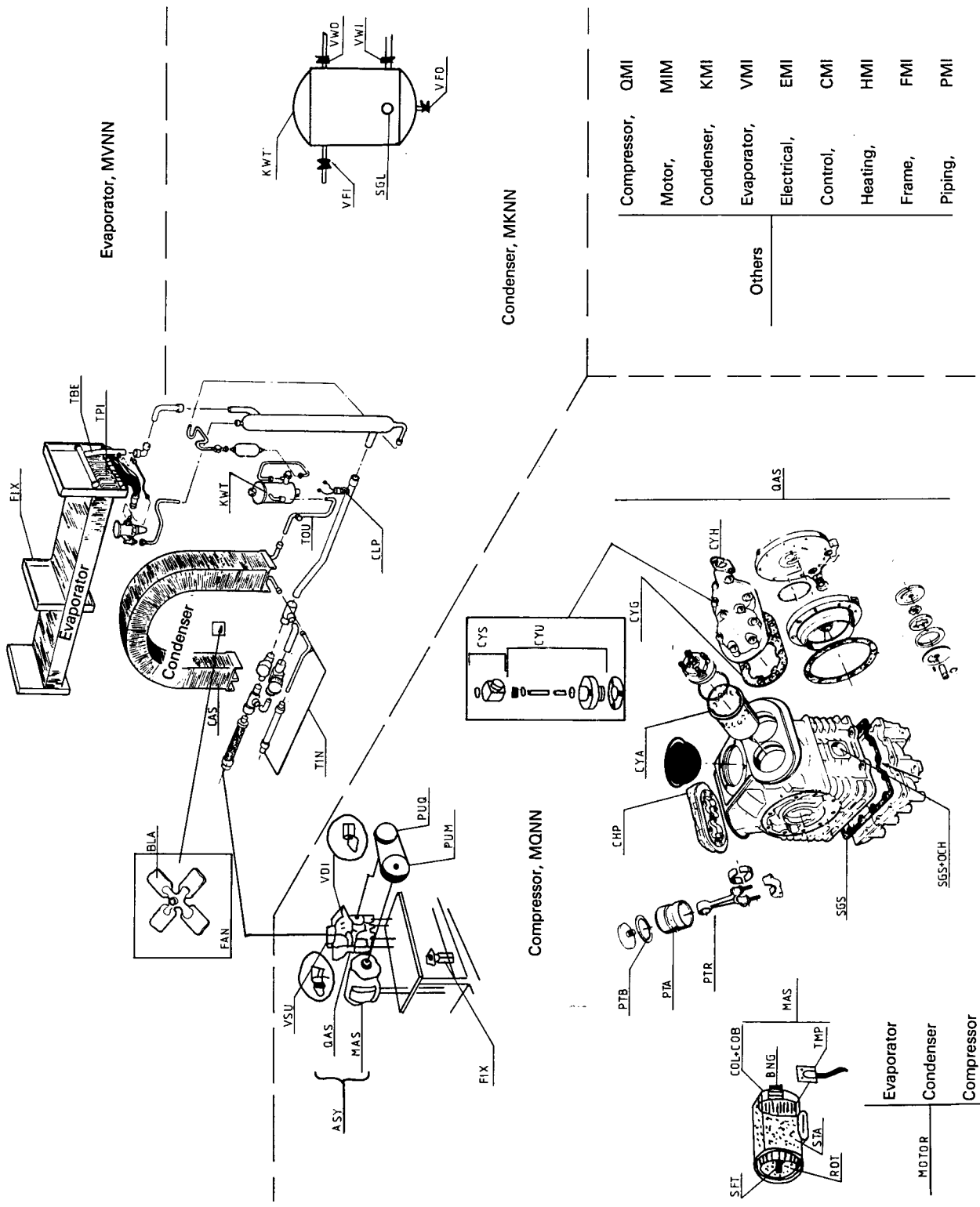

Figure K.4

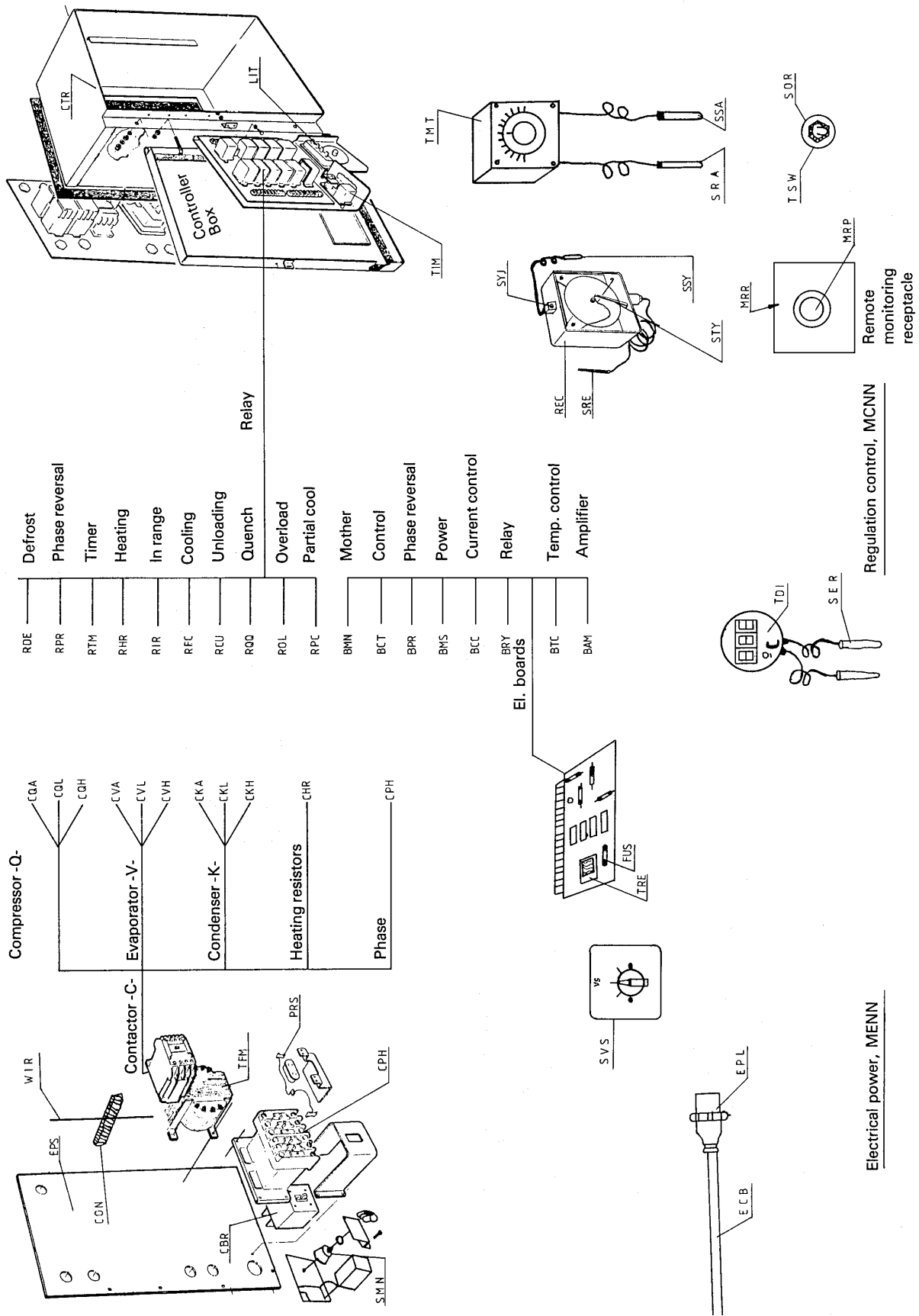
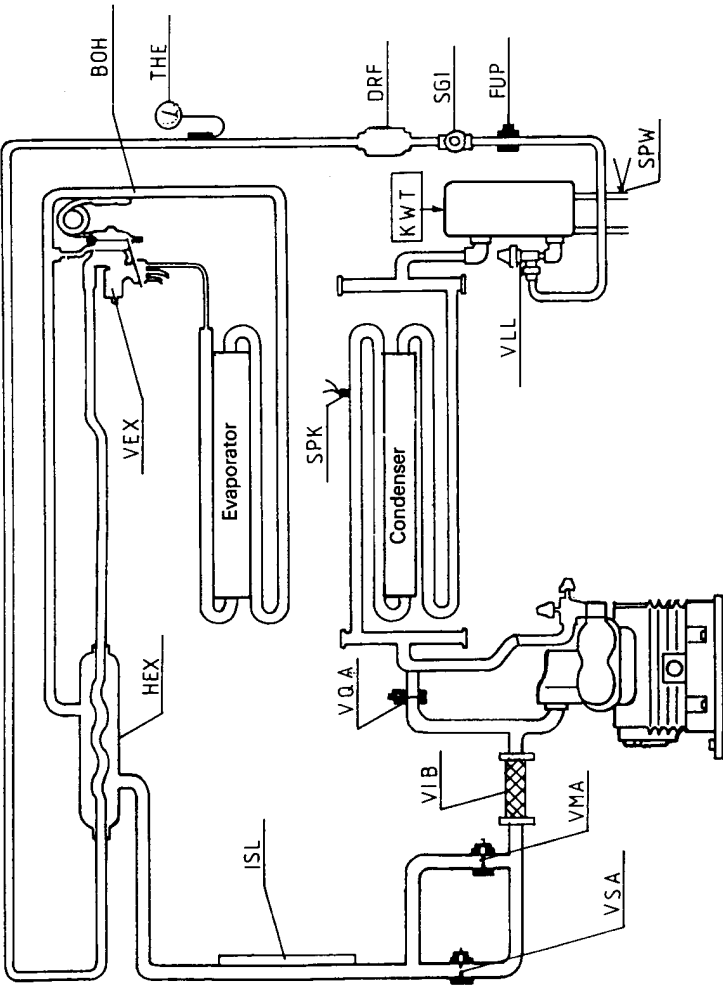
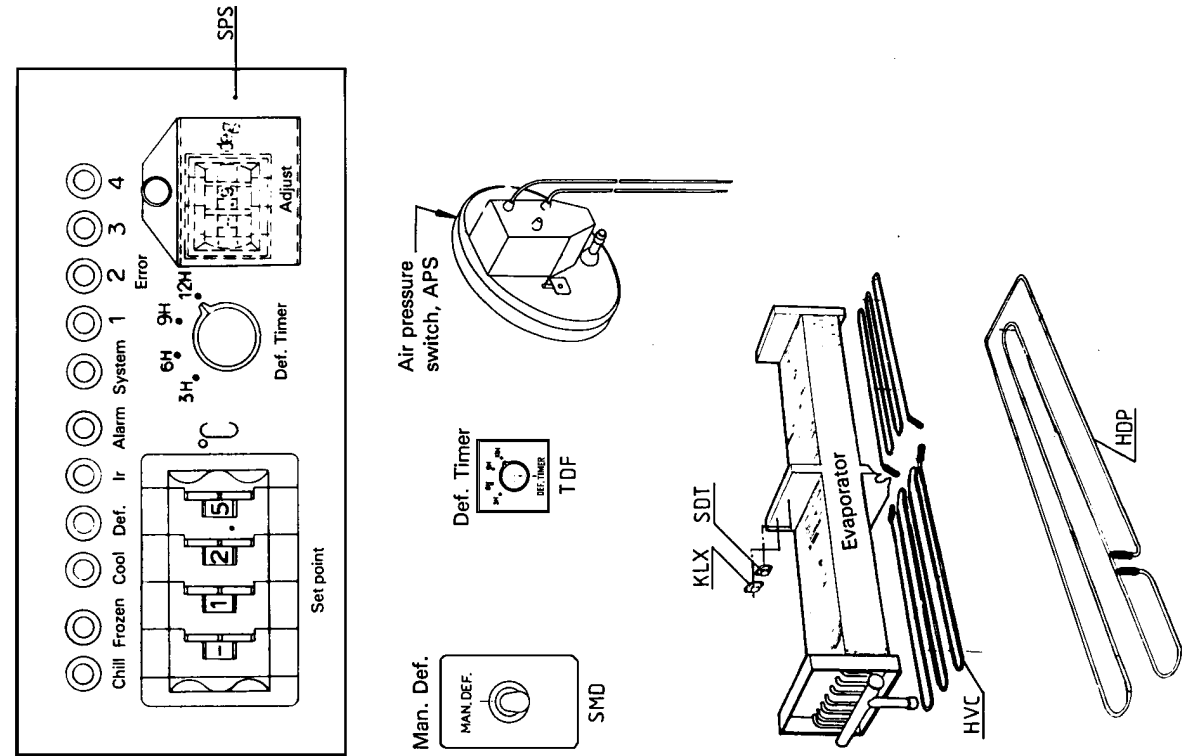
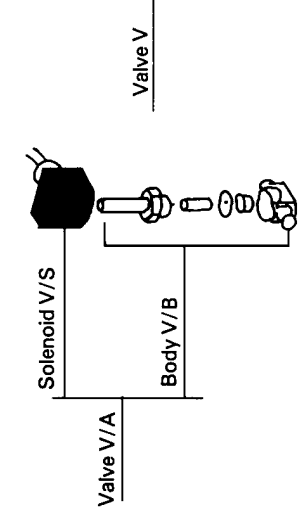

Figure K.5

Defrost - heating, MHNN



Quench	VQA	VQS	VQB
Modulating -M-	VMA	VMS	VMB
Suction -S-	VSA	VSS	VSB
HGMV -G-	VGA	VGS	VGB



Piping, MPNN

Figure K.6

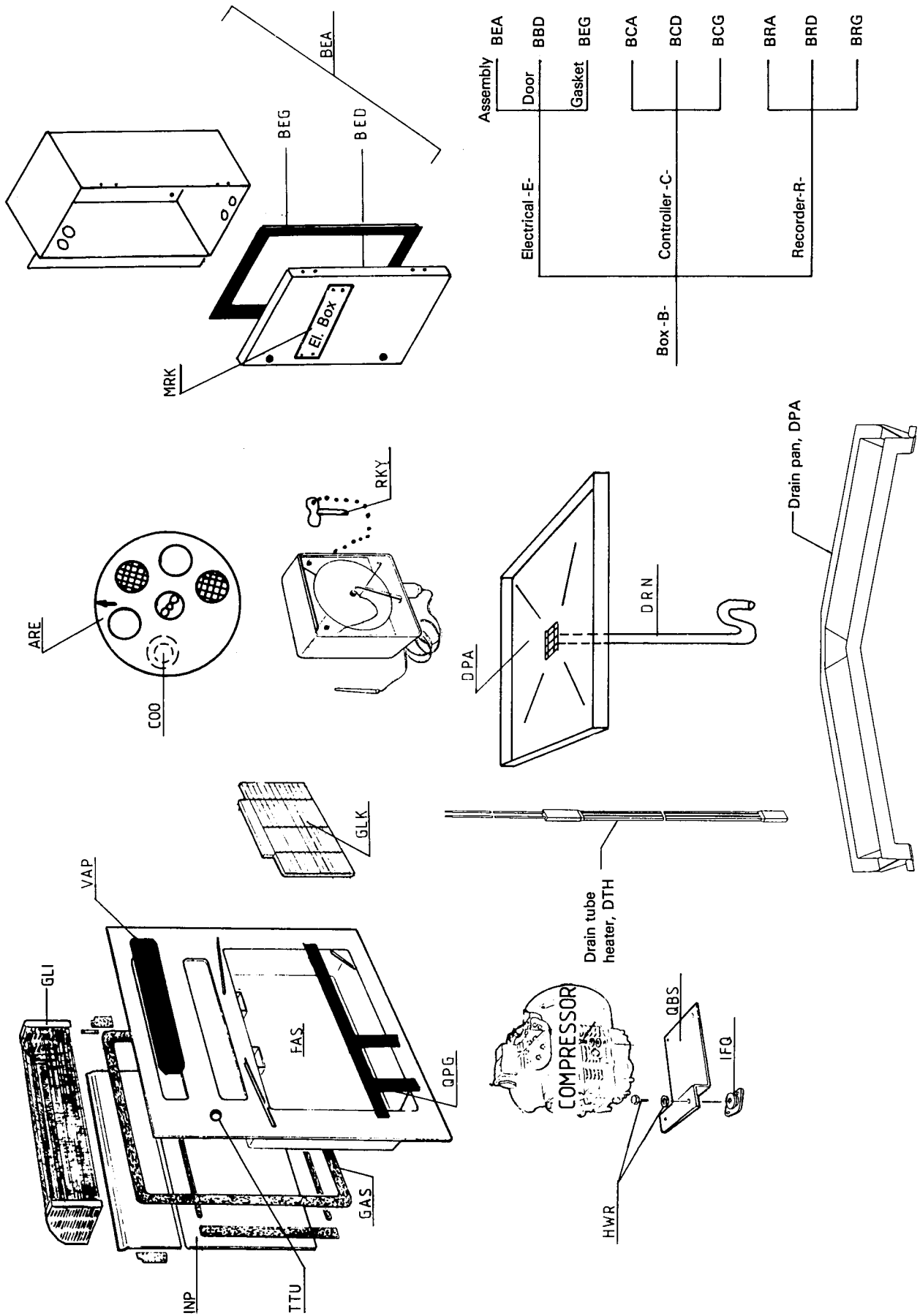

Figure K.7

Annex L (normative)

Codes — Components of chassis

(see 4.1 and 4.2)

Numerical code	Name	Description	CEDEX code
90010	Air coupling	Fittings for connecting air brake lines between vehicles Alternative: Gladhand, 90310	KAC
90012	Air hose support spring	Device used to support brake hoses (component 90090) or brake lines (components 90092 and 90096) so they do not chafe on chassis components or pavement	KHS
90014	Air ride suspension assembly (without bladder)	Suspension which utilizes flexible pneumatic cushioning bladders, which are pressurized by tractor air and regulated by height control valves or variable pressure regulators	KAR
90015	Air suspension bladder	Flexible pneumatic cushioning device, pressurized by tractor air, in air ride suspension assembly	KAB
90016	Anchor pin	Pin which secures two brake shoes in a foundation brake, and about which the brake shoes rotate when brake application is made	KAP
90017	Anti-skid controller	Computerized control module in an antiskid brake assembly	KSC
90018	Anti-skid assembly	Device which, when incorporated into a service brake system, automatically controls the degree of rotational wheel slip at one or more wheels of an undercarriage during braking	KSK
90020	Axle assembly	Rectangular, square, or circular steel tubes with spindles pressed onto the ends about which wheels rotate	KAX
90025	Axle nut (wheel axle)	Nut on the end of a wheel axle which retains the wheel bearings, wheel bearing cups, and wheel bearing lock washer. Code may also be used for intermediate nuts for securing wheel bearings to the axle.	KAN
90030	Axle spindle	Machined shaft at each end of the axle	KAS
90040	Bicycle guard	Railing, mounted along the outside of the chassis between the landing gear assembly and the rear axle assembly, to guard against cyclists accidentally falling underneath	KBG
90050	Bolster	Transverse structural member designed to support the container in a fixed position	KBO
90055	Bolster gusset support/bracing	Gusset or brace which stiffens a chassis bolster to resist longitudinal shocks	KGU
90060	Brake assembly	Brake system	KBK
90070	Brake	Parts of the braking system in which the forces opposing the movement or tendency to movement, of a vehicle are produced	KBC
90072	Brake chamber mounting bracket	Bracket attached to an axle for mounting the spring brake (component 90780)	KBM

Numerical code	Name	Description	CEDEX code
90074	Brake chamber push rod	Rod which exists from chamber of the spring brake (component 90780) and extends outward upon brake application to rotate the brake slack adjuster and brake S-cam shaft, in turn engaging brake shoe lining and brake drum	KPR
90076	Brake clevis	U-shaped metal shackle with the ends drilled to receive a clevis pin, which attaches the brake chamber push rod to the brake slack adjuster	KCV
90078	Brake clevis pin	Pin, which inserts through the drilled ends of the brake clevis, to retain the brake clevis	KCP
90080	Brake drum	Cylindrical rotating member of a wheel which is acted upon by frictional material (brake shoes) of the brake system	KBD
90090	Brake hoses	Flexible or rigid conductor for the transmission of air pressure in the brake system	KBH
90092	Brake line, emergency	Hose which carries air from the tractor compressor through the chassis brake valve(s) to the reservoir (component 90680)	KBE
90096	Brake line, service	Hose which transmits the brake-actuating signal from the tractor to the chassis brake valve(s)	KSR
90100	Brake lining	Lining of the brake shoes that act upon the brake drum	KBL
90102	Brake quick release valve	Valve placed in the service brake line to accelerate the release of pressurized air in the line	KQR
90103	Brake rollers	Cylindrical rolling pins in the brake shoe assembly which, upon brake application, roll along the S-cam of the brake S-cam shaft, spreading the brake shoes apart, and causing contact of brake shoes and brake drum	KRO
90104	Brake S-cam bushing	Hollow cylinder which reduces friction at the rotation point of the brake S-cam through the brake spider	KCH
90105	Brake S-cam shaft	Shaft having an S-shaped cam which moves brake rollers, thereby spreading shoes apart to make linings contact the brake drum	KCS
90106	Brake shoe (with lining)	Curved, flange-stiffened metal plate with friction-absorbing material attached, which contacts the brake drum to cause braking	KSE
90108	Brake shoe assembly (with lining)	Assembly consisting of two lined brake shoes, brake rollers, and miscellaneous hardware including brake anchor pin, other pins, and springs	KSA
90110	Brake spider	Centre plate, either bolted or welded to the axle, to which the brake assembly is attached	KBS
90120	Bulb	Light bulb for lights	KSG
90130	Bumper	Structure designed to provide rear-end impact protection	KBP
90132	Bumper filler plate	Plate which fits between the uprights in the bumper, to which the licence plate may be attached	KBF
90134	Bumper uprights	Vertical stiffening members in the bumper	KBU

90136	Bumper crosspiece	Horizontal member at the base of the bumper, which is attached to the bumper uprights	KBQ
90138	Chassis	Entire chassis, including sliding mechanism and running gear	MCH
90140	Circuit breaker	Electrical overload protection device which opens a circuit upon sensing excessive voltage or heat	KCB
90150	Certification label	Label permanently affixed, usually to the forward left side of the chassis, stating that the vehicle conforms to all applicable safety standards in effect on the date of original manufacture (for example in United States, as required by National Highway Traffic Safety Administration)	KCL
90160	Clearance lights	Lights visible to the front or rear of a vehicle, mounted on the permanent structure of the vehicle as near as practicable to the upper left and right extreme edges, to indicate the overall width and height of the vehicle. The front and rear clearance lights of a container chassis are sometimes combined with the front and rear side marker lights, respectively	KLT
90170	Connection box	Box containing fittings for the chassis emergency and service brake connections and the electrical connector to which the lines from the towing vehicle may be connected (also called "Nose box", 90580)	KBX
90180	Container guides	Structural member on the front of a container chassis to serve as gathering device for guiding a container into its proper place on the chassis Alternative: Horn, 90350	KCG
90185	Cross-member, chassis main frame	Transverse member in the chassis main frame	KXM
90188	Cross-member gusset/stiffener	Plate or angle which reinforces and stiffens connections of main frame cross-member flanges and main rails	KXG
90190	Dock bumper	Cushioning devices (rubber, plastics, wood, etc.) mounted at the extreme rear of chassis to take the initial impact of the vehicle when it backs into loading dock platform	KDP
90200	Document holder	Pocket or tube for carrying documents (for example registration papers)	KDH
90210	Drain	Valve or petcock fitted to the air reservoir or other low point in the air system to allow for drainage of moisture that may have condensed in the air system	KDV
90220	Dummy coupler	Fitting used to seal the opening in an air brake hose connection (gladhand) when the connection is not in use; a dust cap	KDC
90230	Dust shield	Plastic or metal cover mounted on the brake spider to provide inner wheel protection from road debris	KDS
90240	Dust cover	Plastic or metal cover mounted on the landing gear to provide protection from road debris	KDM
90250	Electrical connector	Receptacle (socket) designed to accept truck tractor electrical cable plug Alternative: Seven-pin plug, 90720	KEC

90260	Extending assembly	Assembly on the main rails that provides a convenient means of extending the length of a chassis to carry different-length containers [for example 12 m (40 ft), 13,5 m (45 ft), 14,5 m (48 ft)]	KEX
90270	Emergency assembly	Part of the chassis air brake system used by the driver to stop the vehicle in an emergency. Loss of air caused by a rupture in the system or by a breakaway will also cause an emergency brake application	KEA
90280	Fender	Rigid structure mounted over tyres to prevent damage from debris picked up by the tyres Alternative: Mudguard, 90570	KFD
90290	Flap	Protection for the inner tube in a tubed tyre	KFL
90292	Frame extension rollers/slide pads	Rolling pins or friction-inhibiting pads which facilitate movement of the chassis-extending assembly during extension or retraction	KFS
90296	Frame extension pin lock	Locking mechanism which secures the chassis-extending assembly in any selected position	KFP
90300	Gear box	Mechanism through which landing legs are raised or lowered	KGR
90310	Gladhand	(See Air coupling, 90010)	KAC
90315	Gladhand seal	Gasket fitted to the inside of a gladhand (air coupling) to prevent air leaks	KAA
90320	Gooseneck	Upper level of the front of a gooseneck chassis together with the structure connecting it to the lower level. The gooseneck rails fit into the tunnel recess of containers so constructed	KGN
90322	Grease fitting	Nipple used for the introduction of grease into moving parts	KBZ
90326	Grease seal (wheel bearing)	Device used to retain grease lubricant in the bearing area of a wheel bearing lubricated with grease	KGS
90330	Grommet	Tubular insert, transition piece or bushing which separates one part (frequently a fastener) from another part for purposes of reduced friction, insulation, ease of assembly, etc.	KGM
90335	Hardware, miscellaneous	Screws, nuts, bolts, and similar items	HWR
90340	Hitch	Connecting device at the rear of one vehicle used to pull a second semi-trailer or chassis by use of a convertor dolly Alternative: Pintle hook, 90630	KHI
90350	Horn	(See Container guides, 90180)	KCG
90360	Hubcap	Cap that fits over the end of the axle to seal in lubricant and keep out road dirt. In an oil-bearing axle, is fitted with an oil-filling plug	KHC
90362	Hubcap - grease	Hubcap fitted on wheels having bearings lubricated with grease	KGH
90366	Hubcap - oil	Hubcap fitted on wheels having bearings lubricated with oil	KOH
90370	Hub odometer	Device positioned in the hub of the wheel on a chassis which records the mileage of the chassis	KHU

90380	Identification lights	Three lights at the rear in a horizontal row, mounted on the permanent structure near to the centreline and top of the vehicle	KIC
90390	Kingpin assembly	Kingpin plate reinforcement framing and kingpin mounted on a chassis (also called "upper couples assembly" or "upper fifth wheel")	KKA
90400	Kingpin	Attaching pin on a semi-trailer chassis that mates with and pivots within the fifth wheel of a truck tractor or convertor dolly while coupling the two units together	KKP
90410	Kingpin plate	Part of the kingpin assembly that rests on the fifth wheel of the truck tractor	KKT
90420	Kingpin reinforcement framing	Part of the kingpin assembly that holds the kingpin in position	KKF
90430	Landing-gear assembly	Device, generally adjustable in height, used to support the front end of a container chassis in an approximately level position when disconnected from the towing vehicle	KLA
90432	Landing-gear axle housing	The lowest portion of the inner landing leg, which houses and retains the landing leg wheel/shoe axle	KHA
90436	Landing-gear brace ear	Bracket through which landing gear braces are fastened to an outer landing leg	KLZ
90440	Landing-gear handle	Handle for operating the landing gear mechanism	KLH
90445	Landing-gear crankshaft	Shaft, turned manually by the landing gear handle, which works gearing to raise or lower the landing gear	KKS
90450	Landing-gear cross-shaft	Shaft connecting the mechanism on the handle-side leg to the mechanism on the other leg	KLY
90452	Landing-gear internal gear	Gear which enables the landing legs to be raised or lowered at different speeds	KLJ
90455	Landing-gear mounting bracket	Bracket or box structure which protrudes from the main rail for the purpose of mounting a landing leg to the main rail	KLM
90457	Landing-gear shaft bushing	Cylinder used to facilitate rotation of shafts in the landing gear assembly	KLD
90458	Landing-gear roll pin	Any round hollow pin which secures landing-gear gears to shafts	KLR
90460	Landing-leg bracing	Steel support for landing legs in forward or aft direction or between the two legs	KLB
90470	Landing-leg assembly	Vertical adjustable supporting members of the landing gear, comprising an outer leg secured to the chassis frame and an inner leg, to which are attached sandshoes or wheels, which is raised or lowered by mechanical means	KLL
90480	Landing leg, outer	Outer part of the landing leg assembly	KLO
90490	Landing leg, inner	Inner part of the landing leg assembly	KLI

90500	Landing-leg sandshoe	Flat plate or dish on the landing leg used to transmit the load to the ground (as an alternative to a wheel)	KLN
90510	Landing-leg wheel	Wheel of the landing leg used to transmit the load on the landing gear to the ground (as an alternative to a sandshoes)	KLW
90520	Landing-leg wheel/shoes axle	Axle used to secure the sandshoe on the wheel to the landing leg	KLE
90522	Landing-leg duct cap	Plate closing the end of a landing leg	KLQ
90530	Lens	The translucent part of a lamp assembly through which light passes. Commonly coloured red or amber or, for the licence plate light, white	KLS
90540	Licence plate	Plate exhibiting the registration number of a vehicle, mounted at the rear of a trailer	KLC
90550	Licence light	White light used to illuminate the licence plate	KLG
90552	Licence light assembly	Lamp, lamp holder and attached wiring used for illuminating licence plate	KLP
90555	Lug nut	Threaded nut which retains a tyre and rim assembly on the wheel when fully torqued onto the wheel studs (after mounting over rim clamps in the case of chassis equipped with spoke-type wheels)	KLU
90560	Mud flap	Curtain or shield at the rear of tyres to deflect downwards any splash guard, 90760	KMF
90565	Mud flap mounting bracket	Bracket or angle to which the mud flap is mounted	KMB
90570	Mudguard	(See Fender, 90280)	KFD
90580	Nose box	(See Connection box, 90170)	KBX
90590	Oil seal	Device used to retain lubricant in the bearing area of the wheel. The sealing member of the seal is usually made of a resilient material such as synthetic rubber which is assembled into a wheel or hub bore	KOS
90600	Main rail(s)	Main longitudinal structural member(s) of a container chassis	KMR
90610	Pick-up plate	Forward extension of the kingpin plate, usually turned upward to facilitate coupling of a truck tractor with the chassis	KPP
90620	Pin lock	Mechanically operated device normally used on a 12 m (40-ft) gooseneck container chassis in order to restrain a container during transport or transfer by the use of pins projected into the front apertures of the container's bottom front corner fittings	KPL
90630	Pintle hook	(See Hitch, 90340)	KHI
90640	Reflectors (rear or side)	Devices used on vehicles to warn the driver of an approaching vehicle by reflecting light from the headlights of the approaching vehicle	KRF
90650	Registration certificate	Governmental registration of the vehicle, usually in paper form, kept in the document holder	KRG

Numerical code	Name	Description	CEDEX code
90660	Relay emergency valve	Combination valve in an air brake system, which controls brake application and which also provides for automatic emergency brake application should the trailer become disconnected from the towing vehicle	KEV
90670	Relay valve	Control unit used to accelerate the application and release of air pressure in a part of the air brake system	KRV
90680	Reservoir	Pressure vessel used to store compressed air for several applications of the vehicle service brakes. Also called "air tank"	KRS
90685	Air tank mounting bracket	Hardware fitted to a frame member of a chassis and used to secure an air tank	KRB
90690	Rim	That part of the wheel on which the tyre is mounted and supported	KRM
90692	Rim clamp (lug)	Clamp mounted on wheel studs and secured by lug nuts which retains the rim assemblies on a spoke-type wheel	KRC
90696	Rim spacer	Ring which fills the void between two adjacent rims for wheels fitted with dual tyres, fixing the position of each rim in the transverse (lateral) direction	KRX
90700	Running lights	Marker, clearance and identification lights of a vehicle required by regulations	KRL
90710	Service braking system	Part of a brake system normally used by the driver to apply and modulate the stopping force of the vehicle	KBA
90720	Seven-pin plug	(See Electrical connector, 90250)	KEC
90730	Side marker lights	Lights which show to the side of a vehicle, mounted to indicate the overall length of the vehicle. They may also be mounted at intermediate locations on the sides	KSL
90740	Slack adjuster	Adjustable mechanical lever used to transmit brake chamber force to the brake cam shaft when brakes are applied. They are so designed that they can be adjusted to compensate for lining wear	KAD
90750	Slider assembly	Undercarriage with a subframe having provision for convenient fore-and-aft adjustment of its location on the chassis	KSD
90752	Slider locking-pin assembly	Mechanism which secures the slider assembly in any selected position	KSX
90755	Slider locking pin	Any pin in the slider locking pin assembly which inserts through a hole in a main rail to secure the slider assembly to the main rails	KSY
90758	Slider lock handle	Operator's handle in the slider locking pin assembly, used to disengage the slider locking pins from the main rails	KSZ
90759	Slider lock handle retainer	Lug, attached to the frame of a chassis, used to secure the slider lock handle in place when not in use	KSV
90760	Splash guard	(See Mudflap, 90560)	KMF
90780	Spring brake	Unit which uses the stored energy of springs to actuate brakes	KSB
90790	Spring suspension assembly	Suspension using one or more cambered steel leaves to absorb road shocks from the axle and transfer loads through suspension components to the suspension subframe. Consists of the components 90800 to 90870	KSU

90800	Adjustable radius rod	Member used to retain axle alignment and, in some cases, control axle torque. It may be extended or retraced for alignment purposes. Normally one adjustable radius rod per axle is used	KRR
90810	Equalizer beam	Suspension device used to transfer and maintain equal load distribution between two or more axles of a suspension. Made to accommodate the ends of the spring	KEQ
90820	Equalizer hanger	Bracket used to mount the equalizer beam of a multiple-axle spring suspension to the suspension subframe. Made to allow for the beam's pivotal movement	KQH
90830	Front spring hanger	Bracket used to mount the front of the suspension on the suspension subframe. Made to accommodate end of the spring	KFH
90840	Nonadjustable-radius rod	Fixed-length member used to retain axle alignment. Normally one non-adjustable-radius rod per axle is used	KNR
90850	Rear spring hanger	Bracket used to mount the rear of the suspension on the suspension subframe. Made to accommodate the end of the spring	KRH
90855	Spring hanger stabilizer pipe	Transverse frame component used to stabilize motion of spring hangers	KHB
90860	Springs	Spring components of the spring suspension assembly	KSS
90870	Spring seat	Suspension component used to support and locate the spring on the axle	KST
90880	U-bolt assembly	Assembly consisting of two bolts in the shape of a U, a spacer and a saddle which secures the axle to the spring seat	KUB
90885	U-bolt saddle	Channel in the U-bolt assembly which supports the curved upper portion of the U-bolt and permits springs, spring seat and axle to be clamped together	KUS
90890	Stoplight assembly	Lights giving warning to indicate that the vehicle brakes are being applied	KSO
90900	Stop, tail and/or turning light assembly	Combination of the stop, tail and/or turning lights in the same housing	KTL
90905	Subframe rails and structure	Longitudinal structural members of the slider assembly subframe and any associated cross-members	KSF
90910	Taillight assembly	Light used to show the rear of a vehicle	KTI
90912	Electrical connector boot	Weather-protective covering of electrical connection	KEB
90915	Light bracket/light housing protector	Bracket on the rear bumper used to mount the tail lights and/or protect the tail lights from impact by use of a protruding flange	KTP
90917	Tension spring	Any of the springs in a foundation brake	KSI
90920	Tyre	a) Tubed: Tyre complete with inner tube, flap/boot b) Tubeless: Tyre complete with valve	KTA

90930	Tyre carrier (spare wheel carrier)	Rack for carrying a spare tyre, usually mounted below the main chassis frame	KTC
90940	Tyre valve	Valve for tubeless tyre	KTV
90950	Transition area	Part of a gooseneck chassis at the transition between the main rails and the gooseneck	KTR
90960	Tube	Inner tube for tubed tyre	KTB
90970	Turn signal lights assembly	Lights mounted on the rear at the right and left sides of a container chassis which indicate an intended change in direction by giving flashing warning signals on the side toward which the turn will be made	KSH
90980	Twist lock	Mechanical device located at the corners of certain designs of container chassis which, when rotated into a locked position with the bottom corner fitting of a container, prevents container disengagement	KTW
90990	Twist-lock handle/ Pin-lock handle	Hand-operated part of the twist lock which permits turning of the shaft; i.e. locking and unlocking of the twist lock and identification of its correct positioning	KTH
90991	Twist-lock or pin-lock handle retainer	Lug, attached to the frame of a chassis, used to secure the twist-lock or pin-lock handle in place when not in use	KTE
90992	Twist-lock riser block spacer	Shim used to raise the elevation of a twist-lock above the frame of a chassis	KTK
90993	Twist-lock housing	Protective enclosure for twist-lock components	KTO
90995	Valve stem cap	Threaded cover to protect the end of the valve stem	KVC
91000	Wheel bearings	Machined parts, usually roller bearings, designed to reduce friction between the axle spindle and also support the load while rotating at high speed	KWB
91010	Wheel-bearing cup/race	Tapered ring which holds a wheel bearing cone in which the bearings rotate	KCU
91020	Wheel-bearing lockwasher	Lockwasher which sits adjacent to a wheel bearing or axle retention nut and helps maintain the bearings in proper position	KWA
91030	Wheel, spoke-type	Type of wheel consisting of integral hub and spokes designed to accept demountable rims, either singly or in pairs with a rim spacer for dual tyres	KSW
91040	Wheel stud	Threaded bolt or shaft integrally mounted in the wheel, used to attach the rims to the wheel	KWS
91060	Wiring harness/wiring	Harness encompassing a complete wiring system for chassis, including a wire for each separate circuit, and a ground (earth) wire; or any separate wire or portion of a wire within that harness	KWH

Annex M (informative)

Alphabetical list of CEDEX codes

CEDEX code	Numerical code	CEDEX code	Numerical code	CEDEX code	Numerical code	CEDEX code	Numerical code
AB	06010	BRD	62710	CO	04110	DHL	10590
AC	06040	BRG	62720	COB	60600	DHR	10610
ACC	62265	BRH	62726	COB	60290	DIK	61536
ADT	61860	BRL	62725	COB	60900	DIS	61535
ADU	50250	BRY	61690	COL	60590	DKK	50395
AFP	62800	BSF	60035	COL	60280	DL	04150
AFS	62810	BT	04020	COL	60890	DO	06075
AJ	06020	BTC	61680	CON	61780	DPA	62610
AOA	50010	BU	04065	CON	61230	DPH	61890
AP	05210	BU	06050	COO	62740	DPL	10635
APS	61870	BW	04030	COS	10270	DPR	10636
AR	06030			CPA	10260	DR	06080
ARD	10640	CAC	62880	CPG	10290	DRA	50385
ARE	62630	CAD	62830	CPH	61220	DRB	60135
ARO	10650	CAH	62840	CPI	10300	DRF	62190
ARP	10660	CAK	61110	CPJ	10310	DRL	10587
ARS	10670	CAQ	61090	CPL	10320	DRN	62660
ASA	50150	CAR	62820	CPO	10330	DRP	50386
ASF	50160	CAS	60510	CPR	10340	DRT	10630
ASG	50165	CAS	60810	CPS	10350	DSC	11625
ASH	50170	CAV	61100	CPT	10360	DSB	11626
ASL	50180	CAW	62980	CPU	61415	DSH	11627
ASP	50190	CB	04130	CQA	61120	DSM	11623
ASY	60010	CBB	61055	CQH	61140	DSO	10588
AU	05200	CBR	61050	CQL	61130	DST	11628
		CC	06070	CRE	61775	DT	04160
B	01110	CCB	60516	CSF	60034	DTH	61880
BAM	61700	CDR	62970	CT	04100	DY	04165
BCA	62670	CDS	62900	CTR	61410		
BCC	61670	CDT	71340	CU	04120	E	01160
BCD	62680	CDY	62870	CVA	61150	EAA	12020
BCG	62690	CFG	10280	CVH	61170	ECB	61020
BCH	62695	CFI	60555	CVL	61160	ECC	61025
BCT	61640	CFI	60855	CW	04117	ECD	61026
BCW	62696	CH	06210	CWA	60700	ECE	61027
BD	06060	CHL	50640	CWN	71410	EDH	62666
BEA	62640	CHP	60160	CYA	60080	EDX	62665
BED	62650	CHR	61210	CYG	60070	EFH	10485
BEG	62660	CHU	50630	CYH	60040	EMI	61250
BEH	62664	CK	04115	CYS	60060	EPE	61015
BES	62738	CKA	61180	CYU	60050	EPL	61010
BK	04040	CKH	61200			EPS	61080
BL	04050	CKL	61190	D	08020	ERD	61445
BLA	60960	CL	04090	DAA	12050	ETS	62960
BMN	61630	CLO	60180	DAH	12060	EVS	61527
BMS	61660	CLP	60170	DB	04140		
BN	04069	CMA	10370	DCA	10586	F	01170
BNG	60610	CMF	10380	DCS	10620	FAN	60950
BNG	60300	CMI	61800	DCU	50136	FAN	60650
BNG	60910	CML	10390	DEF	12045	FAN	60950
BO	04070	CMO	10425	DF	06090	FAS	62510
BOH	62140	CMS	10420	DFA	10585	FCH	62270
BPR	61650	CMT	07040	DGR	10509	FHD	61735
BR	04060	CMU	10400	DHB	10505	FHS	10700
BRA	62700	CMW	10410	DHC	10600	FIX	60640

CEDEX code	Numerical code	CEDEX code	Numerical code	CEDEX code	Numerical code	CEDEX code	Numerical code
FIX	60940	HGB	10490	JEH	80640	JNS	80120
FIX	60340	HGP	10500	JEJ	80470	JNU	81030
FLA	10850	HGT	10960	JEK	81340	JNV	80020
FLB	10710	HHC	10980	JEL	80950	JNX	80160
FLL	10860	HHG	10990	JEM	80700	JNY	80180
FLP	10880	HHR	11000	JEN	80430	JNZ	80280
FLS	10870	HLB	11020	JEO	80460	JOD	81110
FLT	10910	HLH	11030	JEP	80450	JOE	81100
FLU	10890	HLM	11040	JER	80670	JOG	81040
FLW	10900	HMI	61900	JES	80690	JOO	81000
FMI	62770	HMT	61490	JET	80650	JOT	81020
FOT	07020	HN	06115	JEU	80660	JRR	80680
FP	04170	HO	04230	JEY	80770	JSH	80720
FPB	10690	HPC	11669	JFF	81180	JSL	80730
FPP	10720	HPH	11668	JFG	81130	JSO	80740
FR	06110	HRA	50600	JFH	81140	JSP	80760
FRS	10675	HRB	50610	JFI	81200	JSS	80750
FS	04180	HRH	50620	JFO	81210	JST	80710
FSA	11630	HUC	62930	JFP	81170	JWA	81320
FSP	11640	HUM	62940	JFR	81120	JWF	81300
FT	06230	HVC	61810	JFS	81190	JWK	81380
FTP	10730	HWR	90335	JFT	81160	JWP	81370
FUN	11840	HWR	11900	JGC	80050	JWS	81360
FUP	62200	HWR	62580	JGE	80170	JWW	81350
FUS	61730			JGF	80040	JXA	80560
FWA	10680	I	08080	JGH	80060	JXB	80570
FWS	10740	IFQ	62760	JGI	80200	JXC	80600
FZ	04190	II	5430	JGO	81010	JXE	80620
		IN	06125	JGW	81330	JXM	80540
G	01140	INH	07010	JIC	81500	JXP	80580
GAS	62590	INP	62560	JIF	81510	JXR	80610
GD	04200	IP	06100	JJF	80270	JXS	80590
GDI	62210	IR	04240	JJH	80240	JXX	81400
GIN	10450	IS	05420	JJR	80250		
GIO	10460	ISL	62160	JJS	80260	KAA	90315
GLI	62550	IT	06120	JKD	80290	KAB	90015
GLK	62530			JMA	80900	KAC	90010
GO	04210	JAA	80830	JMB	80910	KAC	90310
GP	04220	JAB	80530	JMD	80920	KAD	90740
GRS	10440	JAC	80800	JME	80410	KAN	90025
GS	06360	JAD	80810	JMN	80400	KAP	90016
GSU	62220	JAF	80820	JMP	80420	KAR	90014
GT	06295	JAH	81520	JMR	80930	KAS	90030
GTA	10430	JAL	80840	JMS	80940	KAX	90020
GTO	10470	JAM	81530	JNA	80000	KBA	90710
GW	06380	JAO	81540	JNA	80130	KBC	90070
		JAP	80860	JNB	80100	KBD	90080
H	08010	JAU	80850	JNC	80150	KBE	90092
HAD	10930	JBA	80510	JND	80140	KBF	90132
HAL	10940	JBB	80520	JNE	80090	KBG	90040
HAP	62525	JBC	80500	JNF	80110	KBH	90090
HCL	62770	JBD	80490	JNG	81060	KBK	90060
HCP	11010	JDB	81310	JNH	80070	KBL	90100
HCU	62760	JDD	81150	JNI	80190	KBM	90072
HCV	10950	JDO	81070	JNJ	80030	KBO	90050
HDP	61820	JDP	80220	JNL	81050	KBP	90130
HDS	10970	JED	80480	JNM	80210	KBQ	90136
HEP	11650	JEE	80550	JNP	80230	KBS	90110
HEX	62150	JEF	80440	JNQ	80080	KBU	90134
HGA	10480	JEG	80630	JNR	80010	KBW	90770

CEDEX code	Numerical code	CEDEX code	Numerical code	CEDEX code	Numerical code	CEDEX code	Numerical code
KBX	90580	KLM	90455	KTB	90960	MD	06135
KBX	90170	KLN	90500	KTC	90930	MDH	62745
KBZ	90322	KLO	90480	KTE	90991	MF	04290
KCB	90140	KLP	90552	KTH	90990	MFS	40100
KCG	90350	KLQ	90522	KTI	90910	MHC	40072
KCG	90180	KLR	90458	KTK	90992	MHT	40070
KCH	90104	KLS	90530	KTL	90900	MIM	60330
KCL	90150	KLT	90160	KTO	90993	MIS	40020
KCP	90078	KLU	90555	KTP	90915	MK	06250
KCS	90105	KLW	90510	KTR	90950	ML	04280
KCU	91010	KLX	61830	KTV	90940	MM	04310
KCV	90076	KLY	90450	KTW	90980	MMI	40030
KDC	90220	KLZ	90436	KUB	90880	MMT	07030
KDH	90200	KMB	90565	KUS	90885	MOC	40040
KDM	90240	KMF	90560	KVC	90995	MOL	40300
KDP	90190	KMF	90760	KWA	91020	MPC	40230
KDS	90230	KMI	60730	KWB	91000	MPD	40090
KDV	90210	KMR	90600	KWH	91060	MPL	40260
KEA	90270	KNR	90840	KWS	91040	MPM	40250
KEB	90912	KOH	90366	KWT	62254	MPO	40240
KEC	90720	KOS	90590	KWT	60670	MPS	40200
KEC	90250	KPL	90620	KXG	90188	MPT	40270
KEQ	90810	KPP	90610	KXM	90185	MRC	61755
KEV	90660	KPR	90074			MRK	62750
KEX	90260	KQH	90820	LBA	10510	MRP	61760
KFD	90570	KQR	90102	LBB	10520	MRR	61750
KFD	90280	KRB	90685	LBC	10530	MRU	40290
KFH	90830	KRC	90692	LBF	10580	MS	04320
KFL	90290	KRF	90640	LBG	10540	MSD	40110
KFP	90296	KRG	90650	LBH	10550	MSN	40050
KFS	90292	KRH	90850	LBL	10560	MST	40060
KGH	90362	KRL	90700	LBN	10575	MTR	07050
KGM	90330	KRM	90690	LBR	10570	MTT	40280
KGN	90320	KRO	90103	LBT	11910	MU	05000
KGR	90300	KRR	90800	LC	06130	MUI	40115
KGS	90326	KRS	90680	LF	04270	MV	06297
KGU	90055	KRV	90670	LH	05340	MV	06280
KHA	90432	KRX	90696	LIT	61740		
KHB	90855	KSA	90108	LK	04250	NI	04340
KHC	90360	KSB	90780	LMS	10577	NL	04330
KHI	90340	KSC	90017	LO	04260	NO	04360
KHI	90630	KSD	90750	LPP	10578	NT	04350
KHS	90012	KSE	90106	LPS	10576	NV	04365
KHU	90370	KSF	90905	LS	05350		
KIC	90380	KSG	90120	LSA	10230	O	08050
KKA	90390	KSH	90970	LSB	10240	OCH	60220
KKF	90420	KSI	90917	LSR	10250	OD	04410
KKP	90400	KSK	90018	LU	05330	OI	04420
KKS	90445	KSL	90730			OL	04380
KKT	90410	KSO	90890	M	01130	ONS	62850
KLA	90430	KSR	90096	MA	04300	ONV	62860
KLB	90460	KSS	90860	MAS	60250	OP	06140
KLC	90540	KST	90870	MAS	60560	OR	04370
KLD	90457	KSU	90790	MAS	60860	OS	04390
KLE	90520	KSV	90759	MCA	40080	OU	04400
KLG	90550	KSW	91030	MCC	40010	OX	06155
KLH	90440	KSX	90752	MCE	40210	OXS	62890
KLI	90490	KSY	90755	MCH	90138		
KIJ	90452	KSZ	90758	MCO	12000	P	01120
KLL	90470	KTA	90920	MCS	40220	PA	06150

CEDEX code	Numerical code	CEDEX code	Numerical code	CEDEX code	Numerical code	CEDEX code	Numerical code
PAA	50389	RB	06200	RUP	11610	STC	11410
PAA	11200	RBH	10220	RW	06320	STF	50200
PAF	50460	RBO	10200			STL	61441
PAT	50540	RBP	10225	S	08030	STP	11445
PBH	11210	RBS	10210	SA	04455	STY	61440
PBK	11400	RC	06220	SAA	12010	SU	05100
PBT	50470	RCB	61437	SBR	11390	SVD	61046
PE	05410	RCC	62735	SBS	11380	SVH	61047
PEP	50450	RCH	61435	SC	06390	SVK	61045
PF	04520	RCI	11555	SCC	11860	SVS	61040
PFX	11240	RCK	11520	SCH	11430	SW	04500
PG	05370	RCL	61425	SD	06325	SYJ	61510
PH	04440	RCL	61425	SD	04490		
PHC	50110	RCM	50135	SE	06330	T	08060
PIC	50480	RCR	61426	SER	61520	TBE	60540
PIM	50490	RCU	61590	SES	61523	TBE	60840
PIP	11350	RD	06260	SF	06345	TDF	61840
PIS	50500	RDE	61530	SFT	60030	TDI	61710
PJC	50510	RDP	11530	SG	05150	TFA	50300
PJP	50520	RE	06315	SGA	11450	TFB	50380
PLM	50130	REC	61420	SGF	11460	TFC	50310
PM	05380	RF	04450	SGI	62180	TFD	50320
PMI	62280	RFC	61580	SGL	60720	TFF	50340
POA	50138	RG	06240	SGL	62255	TFG	50350
POC	50530	RHL	11666	SGM	11470	TFI	50370
POL	60320	RHR	61560	SGO	60200	TFM	61060
POL	60630	RIR	61570	SGP	11480	TFP	50360
POL	60930	RIW	11550	SGS	60210	TFS	50330
POM	50120	RKC	62736	SH	04470	THE	61796
POP	11360	RKY	62730	SI	06350	THE	62250
PP	05360	RLA	11510	SK	05120	TIC	11740
PPM	11330	RLE	11661	SLC	11420	TIM	61430
PPO	60190	RLF	11560	SLS	11440	TIN	60520
PPW	11320	RLG	11540	SM	05130	TIN	60820
PR	06160	RLI	11660	SMD	61850	TIR	11750
PRG	62145	RLL	11667	SMM	61030	TMP	60920
PRS	61070	RLT	11620	SN	06340	TMP	60310
PS	06400	RLW	11580	SNB	60175	TMP	60620
PSC	11340	RM	06280	SOR	61770	TMT	61450
PSF	11395	RNG	11590	SP	04460	TNA	11680
PT	06170	RO	04445	SPI	11490	TNB	11690
PTA	60090	ROL	61610	SPK	62230	TNC	11700
PTB	60110	ROT	60580	SPO	11500	TNG	11720
PTR	60100	ROT	60880	SPS	61795	TNS	11710
PU	05400	ROT	60270	SPW	62240	TNX	11730
PUM	60130	RP	06300	SR	04480	TOU	60830
PUQ	60120	RPC	61620	SRA	61470	TOU	60530
PV	06270	RPP	11670	SRE	61460	TOU	60530
PVA	60245	RPR	61540	SRS	50137	TP	06420
PX	06175	RQQ	61600	SRT	62920	TPH	11735
		RR	06290	SRT	62920	TPI	60850
		RRM	50390	SRW	62910	TPI	60550
QAS	60020	RRT	11665	SS	05140	TPN	50322
QBS	62570	RRV	60240	SSA	61480	TR	06500
QDA	60350	RS	06370	SSF	60036	TRF	61720
QMI	60230	RT	06310	SST	11600	TS	04080
OPG	62540	RTL	11585	SSY	61500	TSH	60515
QSS	60033	RTM	61550	ST	05110	TSS	61715
		RU	05440	STA	60870	TSW	61790
RA	06190	RU	06205	STA	60260	TTU	62600
RAA	12030	RUF	11570	STA	60570		

CEDEX code	Numerical code	CEDEX code	Numerical code	CEDEX code	Numerical code	CEDEX code	Numerical code
TU	04510	VVF	50040	YDH	71430	YMR	70570
TUA	11760	VVG	50050	YDI	70320	YMS	71250
TUB	11790	VVH	50060	YDO	71040	YOH	70900
TUC	11770	VVI	50080	YDR	70040	YOM	71000
TUP	11780	VVP	50090	YDV	70750	YPM	71080
TXH	62737	VVR	50020	YEA	71070	YPP	71450
U	08040	VVS	50070	YEC	70850	YPV	70400
UAA	12040	VWI	60710	YEH	70740	YRD	70880
UI	04430	VWO	60720	YEM	70890	YRI	71130
VAP	62520	W	08070	YEU	70330	YRM	70800
VDC	60155	WA	04540	YEV	70360	YRT	71090
VDI	60150	WB	04010	YEW	71060	YRU	70830
VEX	62130	WD	06440	YEX	70870	YSA	70050
VFI	60680	WH	05310	YFF	70010	YSB	71320
VFO	60690	WIR	61240	YFL	70200	YSE	70720
VGA	62100	WM	04580	YFR	71010	YSH	70220
VGB	62110	WN	04570	YFS	70020	YSI	70700
VGS	62120	WP	06410	YFT	70840	YSK	70060
VIB	62260	WS	05320	YFU	71050	YSL	70730
VJT	11850	WT	04560	YFV	70350	YSN	70620
VLL	62170	WTK	62950	YGA	70340	YSP	71300
VM	06180	WU	05300	YHA	71220	YSR	70820
VMA	62040	WV	04550	YHD	70520	YST	70240
VMB	62050	WW	06430	YHE	70250	YSU	70210
VMI	60970	X	01150	YHR	70100	YSV	70710
VMS	62060	XW	06450	YIC	70610	YTA	71020
VQA	62010	YAA	71100	YIN	70600	YTG	70080
VQB	62020	YAV	70370	YIS	70860	YTM	70770
VQS	62030	YBA	70260	YLA	71230	YTR	70810
VRA	11800	YBC	71310	YLG	71240	YTS	70630
VRB	11810	YBF	70380	YLI	71460	YTV	70390
VRG	11830	YBH	70270	YLN	70300	YTW	70760
VRR	11820	YBM	71110	YLO	71330	YUF	70230
VSA	62070	YCC	71420	YLT	70090	YUI	71120
VSU	60140	YCD	70650	YMA	71440	YVP	70070
VTH	62147	YCO	70310	YMC	70500	YWA	71200
VVA	50100	YCS	70640	YMD	70560	YWF	71210
VVD	50030	YCT	71030	YMF	70510	ZZ	06138
		YCU	71400	YMG	70550	ZZ	04355
				YMH	70540	ZZZ	11890
				YMO	70530		
				YMP	70030		

ICS 55.180.10

Descriptors: containers, freight containers, equipment, information interchange, data, data exchange, data elements, codes, data codes.

Price based on 82 pages
