

INTERNATIONAL  
STANDARD

ISO  
9873

Third edition  
2017-04

---

---

**Dentistry — Intra-oral mirrors**

*Médecine bucco-dentaire — Miroirs endobuccaux*



Reference number  
ISO 9873:2017(E)

© ISO 2017



**COPYRIGHT PROTECTED DOCUMENT**

© ISO 2017, Published in Switzerland

All rights reserved. Unless otherwise specified, no part of this publication may be reproduced or utilized otherwise in any form or by any means, electronic or mechanical, including photocopying, or posting on the internet or an intranet, without prior written permission. Permission can be requested from either ISO at the address below or ISO's member body in the country of the requester.

ISO copyright office  
Ch. de Blandonnet 8 • CP 401  
CH-1214 Vernier, Geneva, Switzerland  
Tel. +41 22 749 01 11  
Fax +41 22 749 09 47  
copyright@iso.org  
www.iso.org

# Contents

Page

<b>Foreword</b> .....	<b>iv</b>
<b>Introduction</b> .....	<b>v</b>
<b>1 Scope</b> .....	<b>1</b>
<b>2 Normative references</b> .....	<b>1</b>
<b>3 Terms and definitions</b> .....	<b>1</b>
<b>4 Requirements</b> .....	<b>2</b>
4.1 Dimensions.....	2
4.1.1 Overall length.....	2
4.1.2 Connection between the stem and handle, if applicable.....	3
4.1.3 Dimensions of mirror casing and viewing surface.....	3
4.1.4 Mirror head size designation.....	3
4.1.5 Position of mirror head with respect to the stem.....	4
4.2 Materials.....	5
4.2.1 Mirror glass.....	5
4.2.2 Mirror casing.....	5
4.2.3 Mirror handle.....	5
4.3 Other requirements.....	5
4.3.1 Casing of mirror head.....	5
4.3.2 Reflecting surfaces.....	5
4.3.3 Nominal magnification.....	5
4.3.4 Casing/stem joint strength.....	6
4.3.5 Handle.....	6
4.4 Resistance to reprocessing.....	6
<b>5 Measurement and test methods</b> .....	<b>6</b>
5.1 Visual inspection.....	6
5.2 Resistance to reprocessing.....	6
5.3 Determination of nominal magnification for magnifying mirrors.....	7
5.3.1 Apparatus.....	7
5.3.2 Procedure.....	7
5.4 Distortion.....	7
5.4.1 Apparatus.....	7
5.4.2 Procedure.....	8
5.5 Casing/stem joint strength test.....	8
5.5.1 Apparatus.....	8
5.5.2 Procedure.....	9
<b>6 Marking</b> .....	<b>9</b>
6.1 General.....	9
6.2 Mirror head.....	9
6.3 Mirror handle.....	9
6.4 Package.....	10
<b>Bibliography</b> .....	<b>11</b>

## Foreword

ISO (the International Organization for Standardization) is a worldwide federation of national standards bodies (ISO member bodies). The work of preparing International Standards is normally carried out through ISO technical committees. Each member body interested in a subject for which a technical committee has been established has the right to be represented on that committee. International organizations, governmental and non-governmental, in liaison with ISO, also take part in the work. ISO collaborates closely with the International Electrotechnical Commission (IEC) on all matters of electrotechnical standardization.

The procedures used to develop this document and those intended for its further maintenance are described in the ISO/IEC Directives, Part 1. In particular the different approval criteria needed for the different types of ISO documents should be noted. This document was drafted in accordance with the editorial rules of the ISO/IEC Directives, Part 2 (see <http://www.iso.org/directives>).

Attention is drawn to the possibility that some of the elements of this document may be the subject of patent rights. ISO shall not be held responsible for identifying any or all such patent rights. Details of any patent rights identified during the development of the document will be in the Introduction and/or on the ISO list of patent declarations received (see <http://www.iso.org/patents>).

Any trade name used in this document is information given for the convenience of users and does not constitute an endorsement.

For an explanation on the voluntary nature of standards, the meaning of ISO specific terms and expressions related to conformity assessment, as well as information about ISO's adherence to the WTO principles in the Technical Barriers to Trade (TBT) see the following URL: [www.iso.org/iso/foreword.html](http://www.iso.org/iso/foreword.html).

This document was prepared by ISO/TC 106, *Dentistry*, Subcommittee SC 4, *Dental instruments*.

This third edition cancels and replaces the second edition (ISO 9873:1998), which has been technically revised. It also incorporates the Technical Corrigendum ISO 9873:1998/Cor.1:2000. The following changes have been made:

- deletion of the limitation to metallic mirror cases and handles;
- replacement of water and dry heat test by reprocessing test;
- deletion of hollow-handle leak test.

## Introduction

This document specifies requirements for a type of dental viewing and retracting instrument in common use throughout the world.

However, it is well known that there are also other types of intra-oral mirrors in use which have different designs and/or are made of different materials. Amongst these other types are mirrors with a polished metal reflecting surface (as opposed to a coated glass surface).

Standardization of these other types may form the subject of future work.



# Dentistry — Intra-oral mirrors

## 1 Scope

This document specifies requirements and test methods for reusable intra-oral mirrors with a coated glass reflecting surface used for dental purposes in the oral cavity.

In addition, specific requirements for metallic casing and metallic handles are given.

## 2 Normative references

The following documents are referred to in the text in such a way that some or all of their content constitutes requirements of this document. For dated references, only the edition cited applies. For undated references, the latest edition of the referenced document (including any amendments) applies.

ISO 263, *ISO inch screw threads — General plan and selection for screws, bolts and nuts — Diameter range 0,06 to 6 in*

ISO 724, *ISO general-purpose metric screw threads — Basic dimensions*

ISO 965-1, *ISO general purpose metric screw threads — Tolerances — Part 1: Principles and basic data*

ISO 1942, *Dentistry — Vocabulary*

ISO 5864, *ISO inch screw threads — Allowances and tolerances*

## 3 Terms and definitions

For the purposes of this document, the terms and definitions given in ISO 1942 and the following apply.

ISO and IEC maintain terminological databases for use in standardization at the following addresses:

— IEC Electropedia: available at <http://www.electropedia.org/>

— ISO Online browsing platform: available at <http://www.iso.org/obp>

### 3.1

#### **intra-oral mirror**

#### **mouth mirror**

handheld dental instrument for intra-oral inspection or inspection and retraction generally comprising the mirror head and the mirror handle

Note 1 to entry: See [Figure 1](#).

### 3.2

#### **mirror head**

assembly comprising a glass reflective surface, casing, packing (if present) and stem

### 3.3

#### **stem**

part of the intra-oral mirror connecting the reflecting surface to the handle

### 3.4

#### **reflecting surface**

layer applied to the mirror glass for the purpose of reflecting light

**3.5 reflecting back surface**

reflecting layer coated onto the back surface of the mirror glass so that the image can be observed through the glass

**3.6 reflecting front surface**

reflecting layer coated onto the front surface of the mirror glass so that the image can be observed with no intervening glass layer

**3.7 plane mirror**

intra-oral mirror whose reflective surface is flat

**3.8 magnifying mirror**

intra-oral mirror whose reflective surface is concave to produce an enlarged image of the object observed

**3.9 viewing surface**

surface of the mirror glass, excluding the bevel, not enclosed by the metal casing

**3.10 distortion**

image deformation due to optical defect(s)

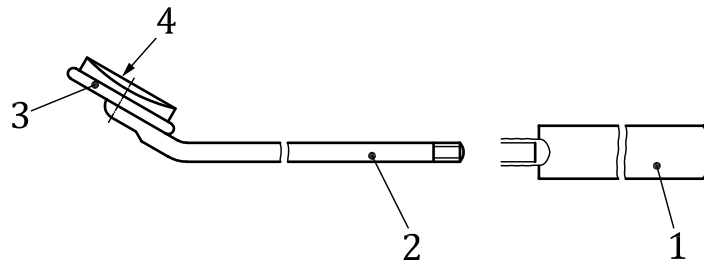

**Key**

- 1 handle
- 2 stem
- 3 mirror head
- 4 reflecting surface

**Figure 1 — Designation for intra-oral mirror parts**

**4 Requirements**

**4.1 Dimensions**

**4.1.1 Overall length**

The maximum length is at the manufacturer's discretion but it should be noted that overall lengths in excess of 178 mm may cause difficulty in containment within a sterilization cassette.



## 4.1.2 Connection between the stem and handle, if applicable

### 4.1.2.1 One-piece design (not applicable)

This requirement is not applicable to intra-oral mirrors with a one-piece design.

### 4.1.2.2 Two-piece design (applicable)

#### 4.1.2.2.1 Metric thread connection

The dimensions of the connection between the stem and handles shall be M 2,5 in accordance with ISO 724. The tolerances for the stem shall be 6e and for the handle 6H, in accordance with ISO 965-1. The length of the thread engagement shall be as shown in [Figure 2](#).

#### 4.1.2.2.2 Imperial thread connection

The dimensions of the connection between the stem and handles shall be imperial thread No. 4-48 UNF, in accordance with ISO 263. The length of the thread engagement shall be as shown in [Figure 3](#).

The tolerances for the stem shall be 2A and for the handle 2B, in accordance with ISO 5864.

## 4.1.3 Dimensions of mirror casing and viewing surface

Mouth mirrors shall meet the dimensions given in [Figure 2](#), [Figure 3](#), and [Table 1](#).

## 4.1.4 Mirror head size designation

The mirror head size designations are based on the nominal diameter of the casing,  $d_1$ , expressed in millimetres. Each subsequent size increases by 2 mm.

**Table 1 — Mirror head and viewing surface**

Dimensions in millimetres

Size designation	Preferred sizes and designation: Nominal head diameter $d_1$	Nominal viewing surface $d_2$
00	12	$d_1 - 2,5$ mm max.
0	14	$d_1 - 2,5$ mm max.
1	16	$d_1 - 2,5$ mm max.
2	18	$d_1 - 2,5$ mm max.
3	19, 20	$d_1 - 2,5$ mm max.
4	21, 22	$d_1 - 2,5$ mm max.
5	24	$d_1 - 2,5$ mm max.
6	26	$d_1 - 3$ mm max.
7	28	$d_1 - 3$ mm max.
8	30	$d_1 - 3$ mm max.

Dimensions in millimetres

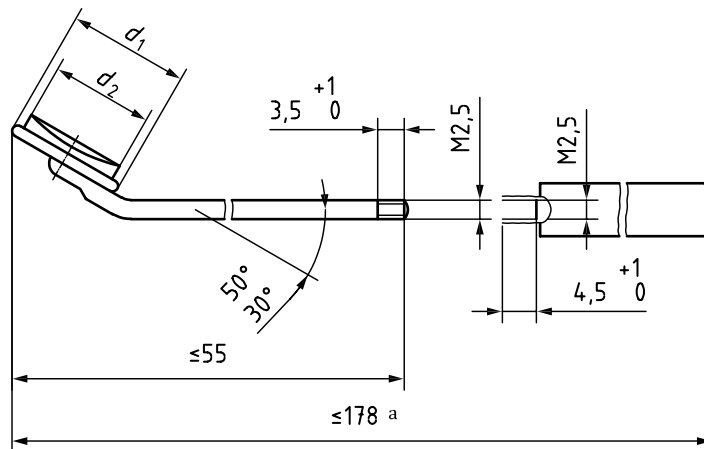

**Key**

a When assembled (recommended overall length).

**Figure 2 — Intra-oral mirror with metric thread connection**

Dimensions in millimetres

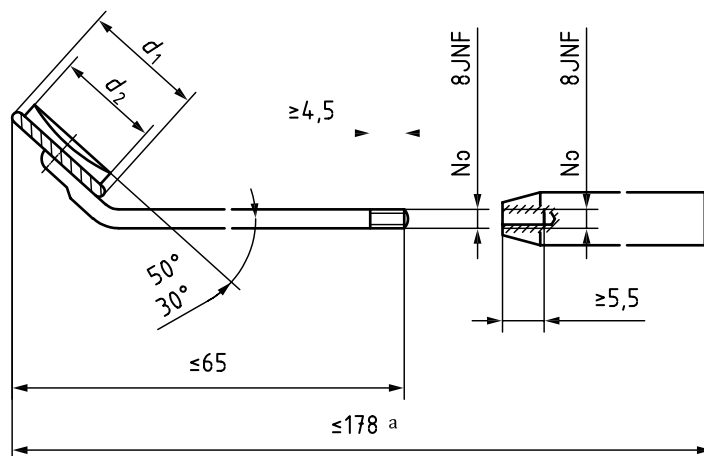

**Key**

a When assembled (recommended overall length).

**Figure 3 — Intra-oral mirror with imperial thread connection**

**4.1.5 Position of mirror head with respect to the stem**

The mirror head shall be positioned such that the long axis of the stem bisects the casing to provide a symmetrical mount about the plane surface of the mirror glass/casing.

Test in accordance with [5.1](#).

## 4.2 Materials

### 4.2.1 Mirror glass

The mirror glass shall be made of polished glass free from visible defects such as waves, chips, scratches and other imperfections observable to the naked eye. Test in accordance with [5.1](#).

### 4.2.2 Mirror casing

#### 4.2.2.1 Metallic mirror casing

The mirror casing shall be made of metal which is resistant to corrosion, e.g. stainless steel or a plated non-ferrous alloy.

Examples of suitable stainless steel or other metal alloys can be found in ISO 7153-1.

#### 4.2.2.2 Plastic mirror casing

The material is left to the discretion of the manufacturer provided that it complies with the requirements of this document.

### 4.2.3 Mirror handle

#### 4.2.3.1 Metallic mirror handle

Mirror handles shall be made of metal which is resistant to corrosion, e.g. stainless steel or a plated non-ferrous alloy.

Examples of suitable stainless steel or other metal alloys can be found in ISO 7153-1.

#### 4.2.3.2 Plastic mirror handles

The material for the plastic mirror handle is left to the discretion of the manufacturer provided that it complies with the requirements of this document.

## 4.3 Other requirements

### 4.3.1 Casing of mirror head

The casing shall have a formed edge which shall be below the level of the viewing surface of the glass and shall be visibly free from burrs, flash or other irregularities. Test in accordance with [5.1](#).

### 4.3.2 Reflecting surfaces

The reflecting surfaces shall allow the image without deformation to be viewed through, or from, the whole of the viewing surface. Test in accordance with [5.1](#).

### 4.3.3 Nominal magnification

The nominal magnification of magnifying mirrors shall be between 2,8 *M* and 3,3 *M*.

Nominal magnification, *M*, is calculated using [Formula \(1\)](#):

$$M = \frac{250}{f} \quad (1)$$

where

$f$  is the focal length, in millimetres;

250 is the least distance of distinct vision, in millimetres.

Test in accordance with [5.3](#).

#### **4.3.4 Casing/stem joint strength**

The mirror casing/stem joint shall withstand the test load without any sign of weld failure. Distortion of the casing is not considered as a failure. Test in accordance with [5.5](#).

#### **4.3.5 Handle**

All external surfaces of the handle shall be visibly free from imperfections. Test in accordance with [5.1](#).

The handle shall show no sign of deterioration, degradation or corrosion after having been tested. Test in accordance with [5.5.2](#) and inspect in accordance with [5.1](#).

### **4.4 Resistance to reprocessing**

Intra-oral mirrors shall withstand 100 reprocessing cycles, as defined by the manufacturer's instructions, without deformation or showing signs of corrosion. There shall be no visible damage to reflective coating or the ingress of water.

The manufacturer shall specify the maximum number of reprocessing cycles if this is less than 100 cycles. If the manufacturer specifies a maximum number of reprocessing cycles allowed, this specified number shall be used in place of the 100 cycles.

The manufacturer shall specify for the reprocessing cycles if the mirror handle shall be disassembled from the head or not.

After testing in accordance with [5.2](#), the handle shall show no sign of deterioration, degradation or corrosion.

## **5 Measurement and test methods**

### **5.1 Visual inspection**

Conduct visual inspection at normal visual acuity without magnification.

### **5.2 Resistance to reprocessing**

Submit the mouth mirror to 100 reprocessing cycles according to the manufacturer's instructions. The reprocessing cycle shall include the manufacturer's recommended methods of cleaning, disinfection and sterilization.

Inspect all of the surfaces of the instrument for any signs of corrosion/surface defect and loss of integrity of the reflective surface of the mirror.

If the manufacturer specifies a maximum number of reprocessing cycles allowed, this specified number shall be used in place of the 100 cycles.

### 5.3 Determination of nominal magnification for magnifying mirrors

#### 5.3.1 Apparatus

The apparatus for determination of nominal magnification is shown in [Figure 4](#).

The hole, key 1, which is 10 mm in diameter, has cross-wires positioned as shown and a light source situated immediately behind it. A white card, key 2, marked with squares as shown, is fixed close to the hole, so that the image of the cross-wires will be in the same horizontal plane as the cross-wires.

#### 5.3.2 Procedure

Place the mirror (with or without the handle) as shown in [Figure 4](#) and move it forward or backward until the sharpest image is obtained in the centre square of the card. Measure the focal distance,  $f$ , to  $\pm 1$  mm, between the mirror and the card. Calculate the nominal magnification,  $M$ , in accordance with [4.3.3](#).

Dimensions in millimetres

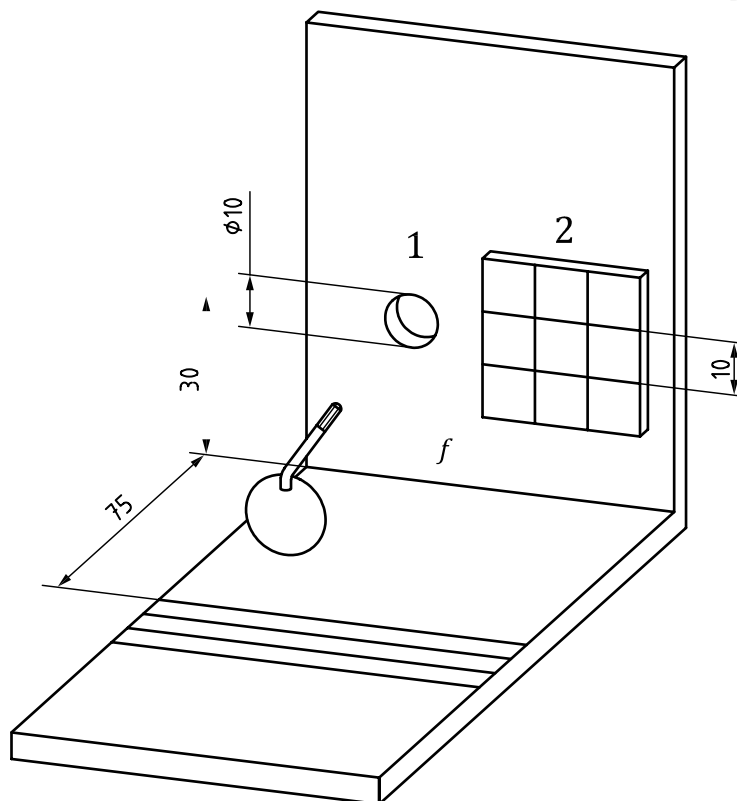

#### Key

- 1 hole
- 2 white card

**Figure 4 — Apparatus for determination of nominal magnification**

### 5.4 Distortion

#### 5.4.1 Apparatus

The apparatus for distortion test is shown in [Figure 5](#).

The upright consists of a rod of 5 mm in diameter with a horizontal crosspiece, key 1, at the midpoint. The mirror rest, key 2, has a groove into which the mirror head is placed.

**5.4.2 Procedure**

Screw the mirror head into the handle and place it in the rest with the handle in the same vertical plane as the upright of the apparatus. View the reflecting surface from a position directly above the upright and move the handle until the image of the intersection of the rod with the crosspiece is visible. Move the mirror vertically up and down, keeping it in line with the upright of the apparatus, and observe whether or not any distortion occurs in the image of the crosspiece and upright.

Repeat the exercise after placing a sheet of graph paper against the crosspiece of the apparatus. Once again, observe whether or not any distortion occurs in the image of the graph paper.

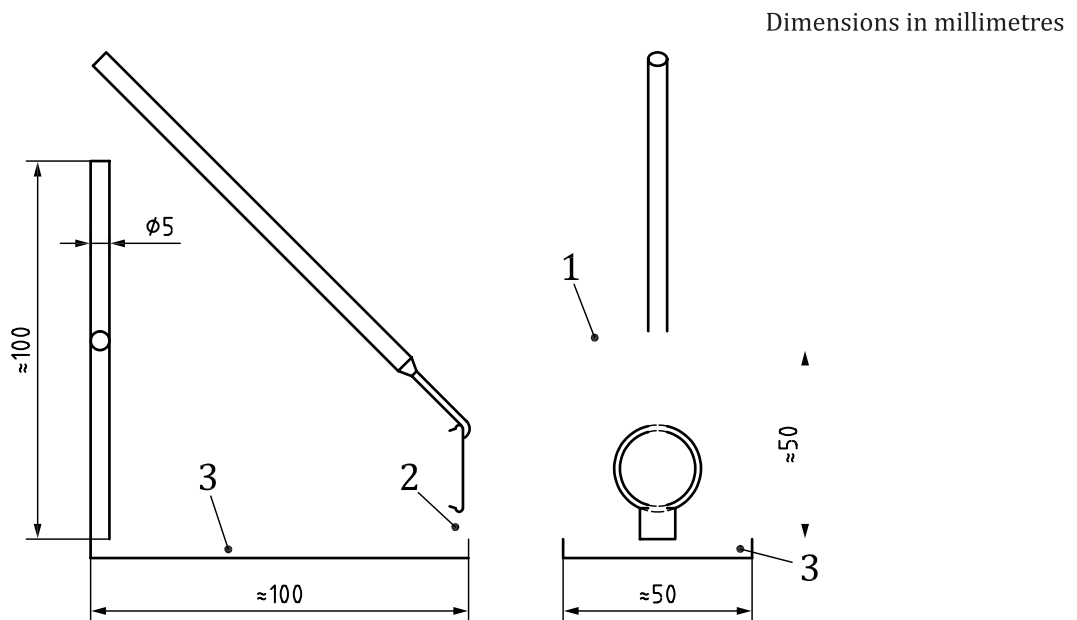

- Key**
- 1 crosspiece
  - 2 mirror rest
  - 3 baseplate

**Figure 5 — Apparatus for distortion test**

**5.5 Casing/stem joint strength test**

**5.5.1 Apparatus**

The clamping device for the mirror casing is shown in [Figure 6](#).

Keys 1 and 2 are two circular metal components shaped so that they fit the inside and outside contours respectively of the casing and stem assembly. Make the slot in component 1 3 mm wider than the stem at the point of union with the casing. The depth of the slot shall be sufficient to ensure that the mirror stem does not come into contact with the side of the slot during the test.

Key 3 is the casing and stem assembly (without glass and packing).

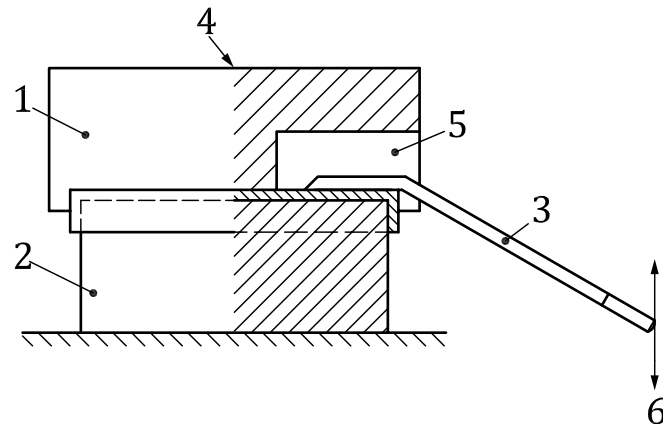
**Key**

- 1 circular metal component with slot
- 2 circular metal component
- 3 mirror casing and stem assembly
- 4 clamp
- 5 slot
- 6 application of force

**Figure 6 — Clamping device for the mirror casing**

**5.5.2 Procedure**

Clamp the mirror and stem in position using components 1 and 2 or a similar fixture. Apply a torque of 1,0 N·m for 5 s at the weld at 90° relative to the mirror head (see [Figure 6](#)).

Visually inspect for signs of weld failure.

**6 Marking****6.1 General**

For intra-oral mirrors with a one-piece design, the marking requirements stated in [6.2](#) and [6.3](#) are only required in one place.

**6.2 Mirror head**

The mirror head shall be indelibly marked with the following information:

- a) name or trade name of the manufacturer;
- b) size designation (number) of mirror head according to [Table 1](#).

**6.3 Mirror handle**

The mirror handle shall be indelibly marked with the following information:

- a) name or trade name of the manufacturer.

#### 6.4 Package

Each package shall be marked with the following information:

- a) name or trade name and address of the manufacturer;
- b) size designation (number) of mirror head according to [Table 1](#).
- c) statement in words whether the mirror is plane or magnifying;
- d) angle of mirror-head;
- e) lot number;
- f) statement in words in which the dimensions of the connection between the stem and handles are shown, imperial thread or metric thread.



## Bibliography

- [1] ISO 68-1, *ISO general purpose screw threads — Basic profile — Part 1: Metric screw threads*
- [2] ISO 6507-1, *Metallic materials — Vickers hardness test — Part 1: Test method*
- [3] ISO 6508-1, *Metallic materials — Rockwell hardness test — Part 1: Test method*
- [4] ISO 7153-1, *Surgical instruments — Materials — Part 1: Metals*
- [5] ISO 17664, *Sterilization of medical devices — Information to be provided by the manufacturer for the processing of resterilizable medical devices*

