

---

---

**Geosynthetics — Determination of  
thickness at specified pressures —**

**Part 1:  
Single layers**

*Géosynthétiques — Détermination de l'épaisseur à des pressions  
spécifiées —*

*Partie 1: Couches individuelles*



Reference number  
ISO 9863-1:2005(E)

**PDF disclaimer**

This PDF file may contain embedded typefaces. In accordance with Adobe's licensing policy, this file may be printed or viewed but shall not be edited unless the typefaces which are embedded are licensed to and installed on the computer performing the editing. In downloading this file, parties accept therein the responsibility of not infringing Adobe's licensing policy. The ISO Central Secretariat accepts no liability in this area.

Adobe is a trademark of Adobe Systems Incorporated.

Details of the software products used to create this PDF file can be found in the General Info relative to the file; the PDF-creation parameters were optimized for printing. Every care has been taken to ensure that the file is suitable for use by ISO member bodies. In the unlikely event that a problem relating to it is found, please inform the Central Secretariat at the address given below.

© ISO 2005

All rights reserved. Unless otherwise specified, no part of this publication may be reproduced or utilized in any form or by any means, electronic or mechanical, including photocopying and microfilm, without permission in writing from either ISO at the address below or ISO's member body in the country of the requester.

ISO copyright office  
Case postale 56 • CH-1211 Geneva 20  
Tel. + 41 22 749 01 11  
Fax + 41 22 749 09 47  
E-mail [copyright@iso.org](mailto:copyright@iso.org)  
Web [www.iso.org](http://www.iso.org)

Published in Switzerland

## Foreword

ISO (the International Organization for Standardization) is a worldwide federation of national standards bodies (ISO member bodies). The work of preparing International Standards is normally carried out through ISO technical committees. Each member body interested in a subject for which a technical committee has been established has the right to be represented on that committee. International organizations, governmental and non-governmental, in liaison with ISO, also take part in the work. ISO collaborates closely with the International Electrotechnical Commission (IEC) on all matters of electrotechnical standardization.

International Standards are drafted in accordance with the rules given in the ISO/IEC Directives, Part 2.

The main task of technical committees is to prepare International Standards. Draft International Standards adopted by the technical committees are circulated to the member bodies for voting. Publication as an International Standard requires approval by at least 75 % of the member bodies casting a vote.

Attention is drawn to the possibility that some of the elements of this document may be the subject of patent rights. ISO shall not be held responsible for identifying any or all such patent rights.

ISO 9863-1 was prepared by the European Committee for Standardization (CEN) in collaboration with Technical Committee ISO/TC 221, *Geosynthetics*, in accordance with the Agreement on technical cooperation between ISO and CEN (Vienna Agreement).

Throughout the text of this document, read “...this European Standard...” to mean “...this International Standard...”.

Together with part 2 (see below), it cancels and replaces ISO 9863:1990, which has been technically revised.

ISO 9863 consists of the following parts, under the general title *Geosynthetics — Determination of thickness at specified pressures*:

- *Part 1: Single layers*
- *Part 2: Procedure for determination of thickness of single layers of multilayer products*

# Contents

Page

Foreword.....	v
1 Scope .....	1
2 Normative references .....	1
3 Terms and definitions .....	1
4 Principle .....	1
5 Apparatus .....	2
6 Specimens .....	2
7 Procedure .....	2
7.1 General.....	2
7.2 Procedure A (New specimens for each pressure).....	3
7.3 Procedure B (Incremental loading of individual specimens) .....	3
7.4 Procedure C (Polymeric and bituminous geosynthetic barriers of non-uniform thickness).....	3
8 Expression of results .....	3
9 Test report .....	4
Annex A (normative) Details of presser points used for geosynthetics of non-uniform thickness .....	5

## Foreword

This document (EN ISO 9863-1:2005) has been prepared by Technical Committee CEN/TC 189 "Geosynthetics", the secretariat of which is held by IBN, in collaboration with Technical Committee ISO/TC 221 "Geosynthetics".

This European Standard shall be given the status of a national standard, either by publication of an identical text or by endorsement, at the latest by August 2005, and conflicting national standards shall be withdrawn at the latest by August 2005.

This document supersedes EN 964-1:1995.

According to the CEN/CENELEC Internal Regulations, the national standards organizations of the following countries are bound to implement this European Standard: Austria, Belgium, Cyprus, Czech Republic, Denmark, Estonia, Finland, France, Germany, Greece, Hungary, Iceland, Ireland, Italy, Latvia, Lithuania, Luxembourg, Malta, Netherlands, Norway, Poland, Portugal, Slovakia, Slovenia, Spain, Sweden, Switzerland and United Kingdom.





## 1 Scope

This part of EN ISO 9863 specifies a method for the determination of the thickness of geosynthetics at specified pressures and defines the pressure at which the nominal thickness is determined.

The test results are intended for identification purposes and for use in technical data sheets and/or as part of other test methods, e.g. tests of hydraulic properties.

The method is applicable to all geosynthetics.

NOTE 1 Normally the thickness of geosynthetics is determined by measuring one layer of the product. When two or more layers are used on top of each other in a design, the test may be made in accordance with this standard with the agreed number of layers instead of one.

NOTE 2 When testing structured geosynthetics, care should be taken to ensure that the results are meaningful for the particular product.

## 2 Normative references

The following referenced documents are indispensable for the application of this document. For dated references, only the edition cited applies. For undated references, the latest edition of the referenced document (including any amendments) applies.

ISO 554 *Standard atmospheres for conditioning and/or testing — Specifications.*

EN ISO 9862, *Geosynthetics — Sampling and preparation of test specimens (ISO 9862:2005).*

## 3 Terms and definitions

For the purposes of this document, the following terms and definitions apply.

### 3.1

#### **thickness**

distance between a reference plate on which the specimen rests and the contacting face of a parallel presser-foot applying a given pressure to the specimen

### 3.2

#### **nominal thickness**

for polymeric and bituminous geosynthetic barriers of uniform thickness, the thickness determined when a pressure of  $(20 \pm 0,1)$  kPa is applied to the specimen

for all other geosynthetics, the thickness determined when a pressure of  $(2 \pm 0,01)$  kPa is applied to the specimen

for textured polymeric and bituminous geosynthetic barriers, the thickness determined when a force of  $(0,6 \pm 0,1)$  N is applied to the specimen

## 4 Principle

**4.1** The thickness of a number of individual specimens of a geosynthetic is measured as the distance between the reference plate on which the specimen rests and the contacting face of a parallel, circular presser-foot exerting a specified pressure on an area of defined size within a larger area of the specimen.

**4.2** At each specified pressure, the result of the test is given as the mean of the values obtained.

## 5 Apparatus

5.1 **Thickness tester**, incorporating the following elements:

5.1.1 **Removable, circular presser-foot**, having a plane and smooth surface with an area as defined in Table 1 for testing materials of uniform thickness. For the determination of the overall thickness of materials of polymeric and bituminous geosynthetic barriers of non-uniform thickness, or the thickness of other parts of such materials, refer to annex A.

**Table 1: Pressure-foot sizes**

Type of geosynthetic under test	Presser-foot size
Polymeric and bituminous geosynthetic barrier	(10 ± 0,05) mm diameter
Other geosynthetic products	(25 ± 0,2) cm <sup>2</sup> area

The presser-foot shall be capable of exerting pressures of 2 kPa, 20 kPa and 200 kPa within a tolerance of ±0,5 % normal to the plane of the specimen.

To ensure that the presser-foot surface and the reference plate are parallel when determining the overall thickness of geosynthetics of non-uniform thickness, except for polymeric and bituminous geosynthetic barriers, the presser-foot shall be supported at not less than three points evenly distributed over the presser-foot surface, which may require that a presser-foot with an area of more than 25 cm<sup>2</sup> be used.

5.1.2 **Reference plate**, with a plane surface of minimum dimensions greater than 1,75 times the diameter of the presser-foot surface for testing material of uniform thickness. When testing thinner areas in materials of non-uniform thickness, the reference plate can be as small as the area of the presser-foot, or an alternative supporting device of these dimensions can be used, to ensure full contact with the lower surface of the specimen.

5.1.3 **Gauge**, for indicating the distance between the reference plate and the presser-foot to an accuracy of 0,01 mm.

5.2 **Means of measuring time** with an accuracy of ±1 s.

## 6 Specimens

6.1 Cut out no less than 10 specimens of minimum dimensions greater than 1,75 times the diameter of the presser-foot.

If new specimens are used for testing at each pressure then not less than 30 specimens will be required.

6.2 Select and cut out the specimens in accordance with EN ISO 9862.

6.3 Condition the specimens in accordance with ISO 554 for a period of 24 h unless it can be shown that the results are not affected by omitting this procedure.

## 7 Procedure

### 7.1 General

When determining the thickness of a material of non-uniform thickness, e.g. a geogrid (see NOTES in 1.2), the part of the material to be tested shall be agreed between the interested parties. The part tested shall be identified in the test report.



The thickness is determined by using the procedure A or C as specified in either 7.2 or 7.4, applying pressures of 2 kPa, 20 kPa and 200 kPa to an accuracy of 0,5 % or a force of  $(0,6 \pm 0,1)$  N.

If agreed between the interested parties procedure B, as specified in 7.3, may be used instead of procedure A.

Other values of pressure may be used if agreed between the interested parties. If a pressure of more than 200 kPa is applied a new, conditioned specimen shall be used for each test.

## 7.2 Procedure A (New specimens for each pressure)

**7.2.1** Place a specimen between the clean surfaces of the reference plate and the presser-foot specified in clause 5. Gently lower the presser-foot applying a pressure of  $(2 \pm 0,01)$  kPa to the specimen, and note the gauge reading after 30 s, unless a longer time is specified.

Release the pressure and remove the specimen.

**7.2.2** Repeat the procedure in 7.2.1 until at least 10 specimens have been tested.

**7.2.3** Repeat the procedure in 7.2.1 and 7.2.2 using a corresponding number of new specimens and applying a pressure of  $(20 \pm 0,1)$  kPa.

**7.2.4** Repeat the procedure in 7.2.1 and 7.2.2 using a corresponding number of new specimens and applying a pressure of  $(200 \pm 1)$  kPa.

## 7.3 Procedure B (Incremental loading of individual specimens)

**7.3.1** Carry out the procedure in 7.2.1 but without removing the specimen.

**7.3.2** Increase the pressure to  $(20 \pm 0,1)$  kPa on the same specimen and note the gauge reading after 30 s, unless a longer time is specified, without removing the specimen.

**7.3.3** Repeat the procedure in 7.3.2 applying a pressure of  $(200 \pm 1)$  kPa. Remove the specimen.

**7.3.4** Repeat the procedures in 7.3.1 to 7.3.3 until at least 10 specimens have been tested.

## 7.4 Procedure C (Polymeric and bituminous geosynthetic barriers of non-uniform thickness)

**7.4.1** Place a specimen between the clean presser points as specified in annex A. Both pressure points shall be the same shape and size. Gently lower the upper presser point applying a force of  $(0,6 \pm 0,1)$  N to the specimen and note the gauge reading after 5 s, unless a longer time is specified. Release the force and remove the specimen.

**7.4.2** Repeat the procedure in 7.4.1 until at least 10 specimens have been tested.

**7.4.3** The purpose of the test is to ascertain the thickness of the barrier, and not of the texturing. The location of the presser points must be chosen to ensure that this is the case.

## 8 Expression of results

Determine the mean thickness of the specimens, and the coefficient of variation, for each pressure given in clause 7 and to the accuracy given in 5.1.3.

NOTE 1 Upon request, the result of each individual determination may be given.

NOTE 2 Upon request, a graphical plot of the mean value of the thickness against the applied pressure may be given. The x-axis (applied pressure) should be logarithmic. The y-axis (thickness) should be linear.

## 9 Test report

The test report shall include the following particulars:

- a) statement that the test was performed in accordance with this document;
- b) number of specimens tested at each pressure given in clause 7;
- c) conditioning atmosphere used (see 6.3) and the time for which the pressure was applied (see 7.2.1);
- d) presser-foot size;
- e) procedure used (A, B or C);
- f) results of the test (see clause 8: nominal thickness in mm and coefficient of variation); mean thickness at other pressures tested and coefficient of variation, if required;
- g) details of any deviation from the specified test procedure;
- h) date of the test.

## Annex A (normative)

### Details of presser points used for geosynthetics of non-uniform thickness

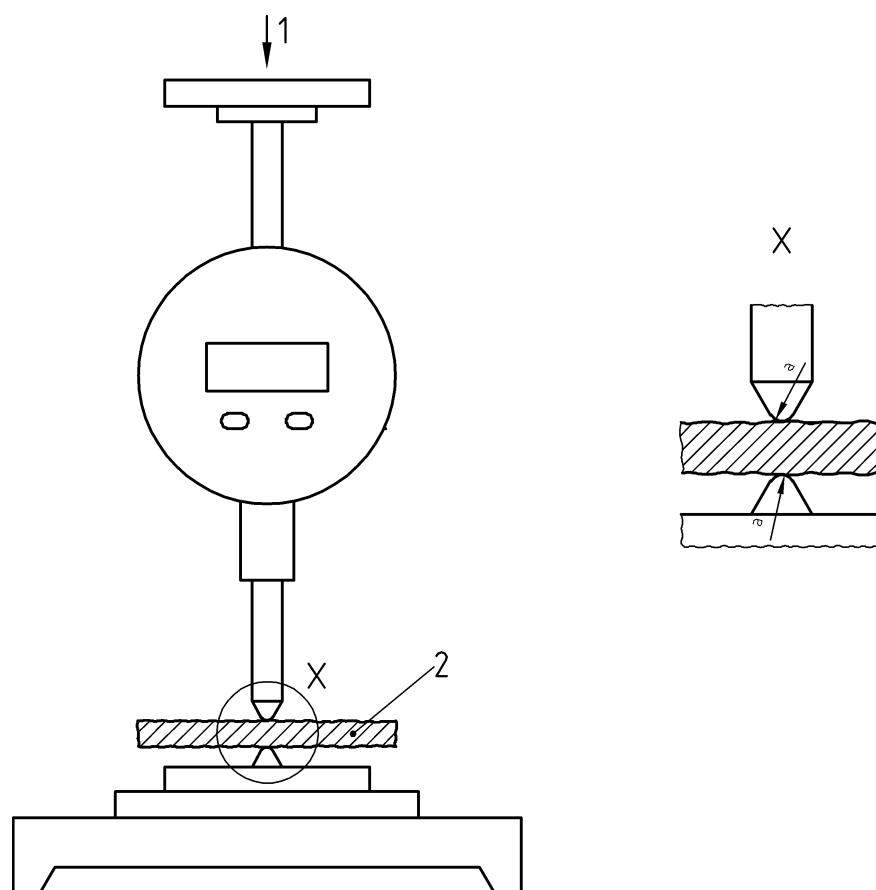

Figure A.1 — Details of presser points used for geosynthetics of non-uniform thickness

#### Key

- 1  $(0,60 \pm 0,1)$  N applied to upper presser point
- 2 Test specimen
- <sup>a</sup> radius of tip  $(1,0 \pm 0,1)$  mm

---

---

**ICS 59.080.70**

Price based on 5 pages