

INTERNATIONAL  
STANDARD

**ISO**  
**9854-1**

First edition  
1994-12-15

---

---

**Thermoplastics pipes for the transport of  
fluids — Determination of pendulum  
impact strength by the Charpy method —**

**Part 1:**

General test method

*Tubes thermoplastiques pour le transport des fluides — Détermination de  
la résistance aux chocs pendulaires par la méthode Charpy —*

*Partie 1: Méthode générale d'essai*



Reference number  
ISO 9854-1:1994(E)

## Foreword

ISO (the International Organization for Standardization) is a worldwide federation of national standards bodies (ISO member bodies). The work of preparing International Standards is normally carried out through ISO technical committees. Each member body interested in a subject for which a technical committee has been established has the right to be represented on that committee. International organizations, governmental and non-governmental, in liaison with ISO, also take part in the work. ISO collaborates closely with the International Electrotechnical Commission (IEC) on all matters of electrotechnical standardization.

Draft International Standards adopted by the technical committees are circulated to the member bodies for voting. Publication as an International Standard requires approval by at least 75 % of the member bodies casting a vote.

International Standard ISO 9854-1 was prepared by Technical Committee ISO/TC 138, *Plastics pipes, fittings and valves for the transport of fluids*, Subcommittee SC 5, *General properties of pipes, fittings and valves of plastic materials and their accessories — Test methods and basic specifications*.

ISO 9854 consists of the following parts, under the general title *Thermoplastics pipes for the transport of fluids — Determination of pendulum impact strength by the Charpy method*:

- Part 1: *General test method*
- Part 2: *Test conditions for pipes of various materials*

Annex A of this part of ISO 9854 is for information only.

© ISO 1994

All rights reserved. Unless otherwise specified, no part of this publication may be reproduced or utilized in any form or by any means, electronic or mechanical, including photocopying and microfilm, without permission in writing from the publisher.

International Organization for Standardization  
Case Postale 56 • CH-1211 Genève 20 • Switzerland

Printed in Switzerland

# Thermoplastics pipes for the transport of fluids — Determination of pendulum impact strength by the Charpy method —

## Part 1: General test method

### 1 Scope

This part of ISO 9854 specifies the general test method to be used for the determination of the impact strength of unnotched test pieces cut from thermoplastics pipes for the transport of fluids.

It is not intended to be a reference test method for the determination of the impact strength of pipes.

ISO 3127, relating to the determination of the impact strength of pipes by means of a falling mass, is the reference method.

However, this part of ISO 9854 may be used for scientific research, materials testing or the examination of pipes when it is not possible to take measurements in accordance with the reference method.

This part of ISO 9854 may be applied to either isolated batches or continuous production of pipe, and the test may be carried out at  $-20\text{ }^{\circ}\text{C}$ ,  $0\text{ }^{\circ}\text{C}$  or  $23\text{ }^{\circ}\text{C}$ , depending on the pipe material and/or size.

For the test parameters, i.e. impact energy, test piece dimensions, shape and spacing of the test piece supports and type of test piece, to be used to determine the pendulum impact strength of pipes, the specifications for specific materials are given in ISO 9854-2, as appropriate.

NOTE 1 Data obtained from test pieces of different dimensions are not directly comparable.

### 2 Normative references

The following standards contain provisions which, through reference in this text, constitute provisions of this part of ISO 9854. At the time of publication, the editions indicated were valid. All standards are subject to revision, and parties to agreements based on this part of ISO 9854 are encouraged to investigate the possibility of applying the most recent editions of the standards indicated below. Members of IEC and ISO maintain registers of currently valid International Standards.

ISO 179:1993, *Plastics — Determination of Charpy impact strength*.

ISO 2818:1994, *Plastics — Preparation of test specimens by machining*.

ISO 9854-2:1994, *Thermoplastics pipes for the transport of fluids — Determination of pendulum impact strength by the Charpy method — Part 2: Test conditions for pipes of various materials*.

### 3 Principle

A short length of pipe, or a strip test piece machined therefrom, is conditioned at a selected temperature,  $T_c$ , and then supported as a horizontal beam, unnotched, and promptly struck once on a line midway between the supports by a pendulum with a given impact energy.

The result is expressed as the incidence of broken test pieces (quantity and percentage) when a specified number of test pieces has been struck.

### 4 Apparatus

**4.1 Pendulum impact-testing machine**, in accordance with ISO 179, with the following characteristics:

- a) Velocity at impact 3,8 m/s.
- b) Pendulums providing maximum impact energies of 15 J and 50 J respectively, with a tapered tip of  $30^\circ \pm 1^\circ$  and a tip radius of  $2 \text{ mm} \pm 0,5 \text{ mm}$ .
- c) Test piece supports in accordance with figures 1 and 2 for longitudinal plane test pieces.
- d) Test piece supports in accordance with figure 3 for circumferential plane test pieces.

**4.2 Ambient equipment**, comprising either a thermostatically controlled enclosure or a liquid bath capable of bringing the test pieces to the specified temperature,  $T_c$  (see clause 6).

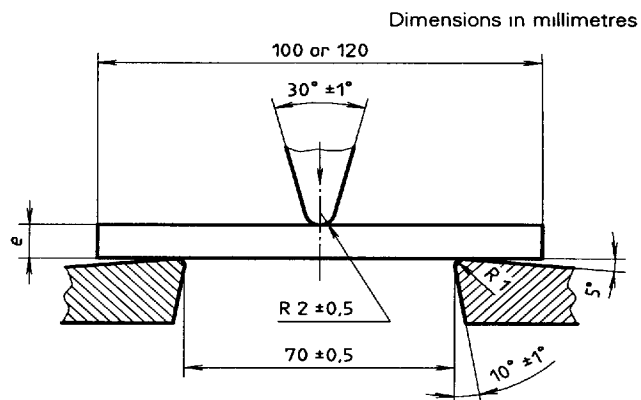

Figure 1 — Striking edge and supports for standard bar test piece

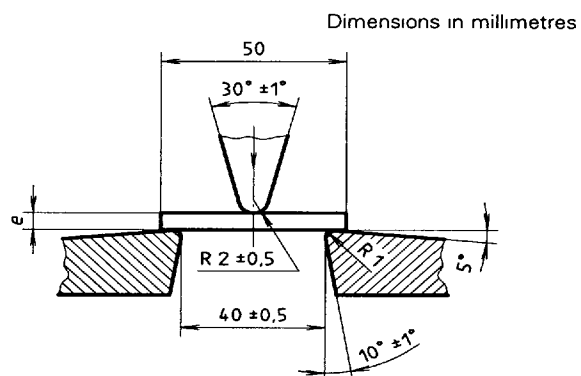

Figure 2 — Striking edge and supports for small bar test piece

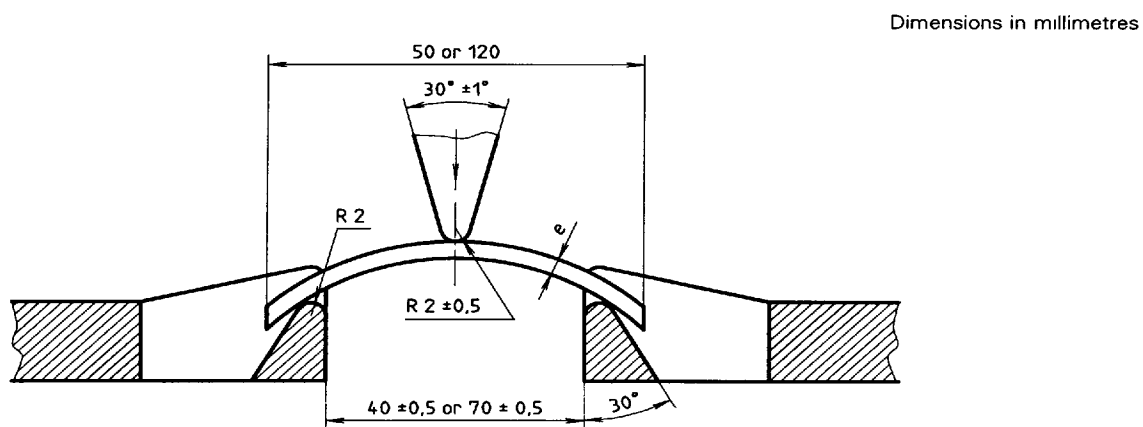

Figure 3 — Supports for convex test piece

## 5 Test pieces

### 5.1 Preparation

The test pieces shall be cut from pipe, in accordance with the procedure of ISO 2818 and with 5.2.1, 5.2.2 or 5.2.3, as appropriate, so that any surface which comes into contact with the anvil, comprising the test piece supports, or with the pendulum at the moment of impact, is smooth and free from burrs.

### 5.2 Cutting and dimensions

**5.2.1** Each test piece for pipes up to 25 mm external diameter shall consist of a length of pipe  $100 \text{ mm} \pm 2 \text{ mm}$  long.

**5.2.2** Each test piece for pipes greater than or equal to 25 mm and less than 75 mm external diameter shall be cut from pipe in the longitudinal direction and shall conform to the dimensions of one of the shapes given in table 1.

**Table 1 — Dimensions of test pieces**

Dimensions in millimetres

Test piece shape	Dimensions of test pieces			Support spacing
	Length	Width	Thickness	
1	$100 \pm 2$	Whole pipe		$70 \pm 0,5$
2	$50 \pm 1$	$6 \pm 0,2$	$e$ 1)	$40 \pm 0,5$
3	$120 \pm 2$	$15 \pm 0,5$	$e$	$70 \pm 0,5$

1)  $e$  is the pipe thickness as manufactured.

**5.2.3** Each test piece for pipes of 75 mm or greater external diameter shall be cut from pipe in the circumferential and longitudinal directions and shall conform to the dimensions of one of the shapes given in table 1.

### 5.3 Number

The number of test pieces shall be as specified in the product standards.

NOTE 2 It is recommended that at least 30 test pieces, taken from the pipe to be examined, be prepared.

## 6 Conditioning

Condition the test pieces in a liquid bath or in air at a temperature of  $-20 \text{ °C} \pm 1 \text{ °C}$ ,  $0 \text{ °C} \pm 1 \text{ °C}$  or  $23 \text{ °C} \pm 2 \text{ °C}$ , as specified in the applicable standard, for the period specified in table 2.

**Table 2 — Conditioning time**

Thickness of test piece $e$ mm	Conditioning time min	
	Liquid bath	Air
$e \leq 8,6$	15	60
$8,6 < e \leq 14,1$	30	120
$e > 14,1$	60	240

In the event of the results being disputed, the liquid bath shall be used.

## 7 Procedure

**7.1** Remove a test piece from its conditioning environment (see clause 6), place it on the appropriate anvil (see clauses 3 to 5) and subject it to an impact of the specified energy on the original pipe outer surface within a time which depends upon the difference between the conditioning temperature,  $T_c$ , and the ambient temperature,  $T$ , in the vicinity of the anvil, as follows (see also 7.2):

- if the temperature difference is less than or equal to  $5 \text{ °C}$ , the test piece shall be struck within 60 s of removing it from conditioning;
- if the temperature difference is greater than  $5 \text{ °C}$ , the test piece shall be struck within 10 s of removing it from conditioning.

**7.2** If the appropriate time limit is exceeded by not more than 60 s, immediately recondition the test piece at the conditioning temperature for at least 5 min and retest in accordance with 7.1; otherwise discard the test piece or recondition it in accordance with clause 6 before testing in accordance with 7.1.

**7.3** Inspect the test piece after impact for damage and record any case of breaking and cracking through the complete thickness of the test piece wall and, if appropriate, any other sign of damage or failure specified in the applicable standard.

**7.4** Repeat the procedures of 7.1 to 7.3 until the specified number of test pieces have been tested (see 5.3).

## 8 Expression of results

Express the number of test pieces which failed, in accordance with 7.3, as a percentage of the total number of test pieces tested.

## 9 Test report

The test report shall include the following information:

- a) a reference to this part of ISO 9854 and to the applicable standard;
- b) all details necessary for the complete identification of the pipe being tested: pipe dimensions and material;
- c) the identity of the batch or production run from which the test pieces were sampled;
- d) the shape of the test pieces and the direction(s) in which they were taken;
- e) the conditioning medium (air or liquid) and its temperature,  $T_c$ , in degrees Celsius;
- f) the energy, in joules, of the pendulum;
- g) the ambient temperature,  $T$ , in degrees Celsius;
- h) for each test piece orientation tested (longitudinal or circumferential, see 5.2):
  - 1) the total number of test pieces tested,
  - 2) the number of failures,
  - 3) the percentage of failures;
- i) any factors which may have affected the results, such as any incidents or any operating details not specified in this part of ISO 9854;
- j) the date of test.

## **Annex A**

(informative)

### **Bibliography**

- [1] ISO 3127:1994, *Thermoplastics pipes — Determination of resistance to external blows — Round-the-clock method.*
- [2] ISO 11173:1994, *Thermoplastics pipes — Determination of resistance to external blows — Staircase method.*

---

---

**ICS 23.040.20**

**Descriptors:** plastics products, pipes (tubes), fluid circuits, thermoplastic resins, plastic tubes, tests, determination, strength, Charpy impact tests, test equipment.

Price based on 5 pages

---

---