**Vacuum technology — Mounting
dimensions of pipeline fittings —**

**Part 1:
Non knife-edge flange type**

*Technique du vide — Dimensions de montage des raccords de
conduit —*

Partie 1: Brides de type sans guillotine



Reference number
ISO 9803-1:2007(E)

© ISO 2007

PDF disclaimer

This PDF file may contain embedded typefaces. In accordance with Adobe's licensing policy, this file may be printed or viewed but shall not be edited unless the typefaces which are embedded are licensed to and installed on the computer performing the editing. In downloading this file, parties accept therein the responsibility of not infringing Adobe's licensing policy. The ISO Central Secretariat accepts no liability in this area.

Adobe is a trademark of Adobe Systems Incorporated.

Details of the software products used to create this PDF file can be found in the General Info relative to the file; the PDF-creation parameters were optimized for printing. Every care has been taken to ensure that the file is suitable for use by ISO member bodies. In the unlikely event that a problem relating to it is found, please inform the Central Secretariat at the address given below.



COPYRIGHT PROTECTED DOCUMENT

© ISO 2007

All rights reserved. Unless otherwise specified, no part of this publication may be reproduced or utilized in any form or by any means, electronic or mechanical, including photocopying and microfilm, without permission in writing from either ISO at the address below or ISO's member body in the country of the requester.

ISO copyright office
Case postale 56 • CH-1211 Geneva 20
Tel. + 41 22 749 01 11
Fax + 41 22 749 09 47
E-mail copyright@iso.org
Web www.iso.org

Published in Switzerland

Foreword

ISO (the International Organization for Standardization) is a worldwide federation of national standards bodies (ISO member bodies). The work of preparing International Standards is normally carried out through ISO technical committees. Each member body interested in a subject for which a technical committee has been established has the right to be represented on that committee. International organizations, governmental and non-governmental, in liaison with ISO, also take part in the work. ISO collaborates closely with the International Electrotechnical Commission (IEC) on all matters of electrotechnical standardization.

International Standards are drafted in accordance with the rules given in the ISO/IEC Directives, Part 2.

The main task of technical committees is to prepare International Standards. Draft International Standards adopted by the technical committees are circulated to the member bodies for voting. Publication as an International Standard requires approval by at least 75 % of the member bodies casting a vote.

Attention is drawn to the possibility that some of the elements of this document may be the subject of patent rights. ISO shall not be held responsible for identifying any or all such patent rights.

ISO 9803-1 was prepared by Technical Committee ISO/TC 112, *Vacuum technology*.

This first edition of ISO 9803-1, together with ISO 9803-2, cancels and replaces ISO 9803:1993, which has been technically revised.

ISO 9803 consists of the following parts, under the general title *Vacuum technology — Mounting dimensions of pipeline fittings*:

- *Part 1: Non knife-edge flange type*
- *Part 2: Knife-edge flange type*

Introduction

ISO 9803:1993 defined only those pipeline fittings whose flanges are non-bakable, as defined in ISO 1609 and ISO 2861-1. This revision divides ISO 9803 into two parts:

- this part of ISO 9803, in which fittings with non-bakable flanges are defined, and
- ISO 9803-2, in which fittings with bakable flanges as specified in ISO 3669 are defined.

This part of ISO 9803 deals with dimensions of pipeline fittings whose flanges are of non-bakable type, as defined in ISO 1609 and ISO 2861-1.

Vacuum technology — Mounting dimensions of pipeline fittings —

Part 1: Non knife-edge flange type

1 Scope

This part of ISO 9803 specifies mounting dimensions for vacuum pipeline fittings (elbows, tees and crosses) of non-bakable and non knife-edge flange for nominal bores from 10 mm to 250 mm of the R5 series.

2 Normative references

The following referenced documents are indispensable for the application of this document. For dated references, only the edition cited applies. For undated references, the latest edition of the referenced document (including any amendments) applies.

ISO 1609, *Vacuum technology — Flange dimensions*

ISO 2861-1, *Vacuum technology — Quick-release couplings — Dimensions — Part 1: Clamped type*

3 Terms and definitions

For the purposes of this document, the terms and definitions given in ISO 1609 and ISO 2861-1 apply.

4 Requirements

4.1 Mounting dimensions of the vacuum pipeline fittings shall be as specified in Table 1. See Figures 1 to 3.

4.2 Flange dimensions shall be as specified in ISO 1609 and ISO 2861-1. One or more flange should be rotatable.

4.3 Bolt holes in the flanges specified in ISO 1609 shall be positioned as shown in Figure 4. Angle α is a function of the number of bolt holes.

Dimensions in millimetres

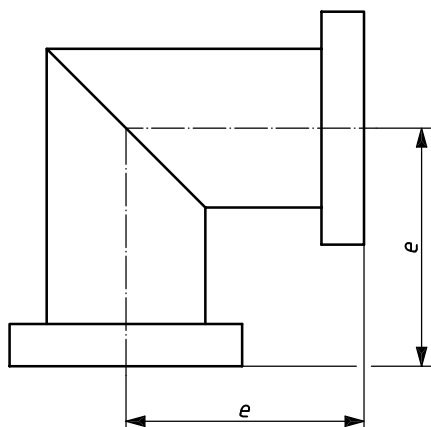

Key

e edge dimension

Figure 1 — Elbow

Dimensions in millimetres

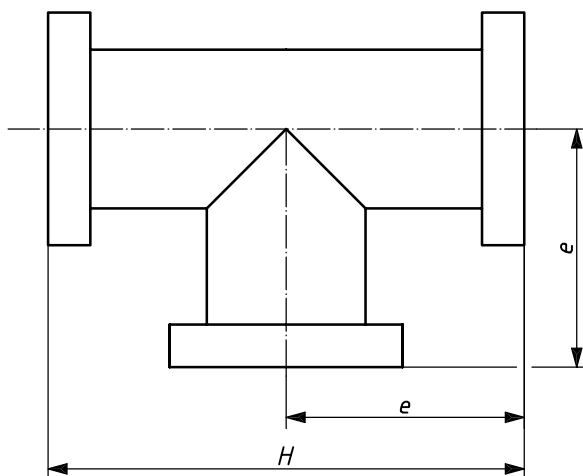

Key

e edge dimension

H length

Figure 2 — Tee

Dimensions in millimetres

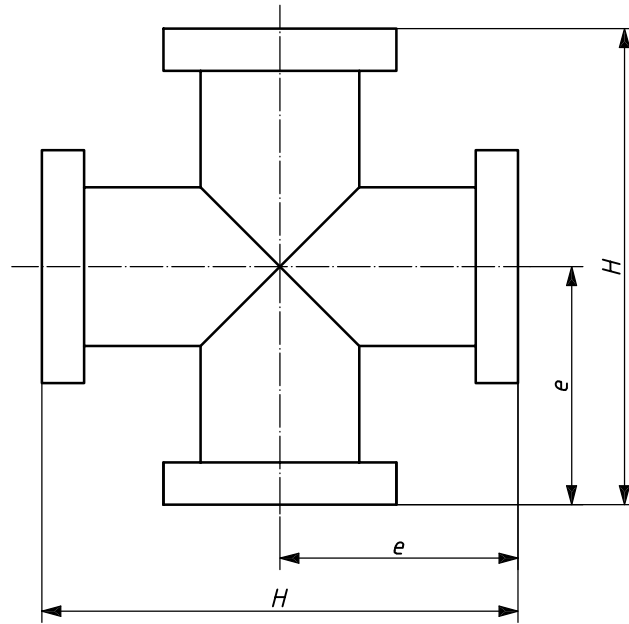

Key

e edge dimension

H length

Figure 3 — Cross

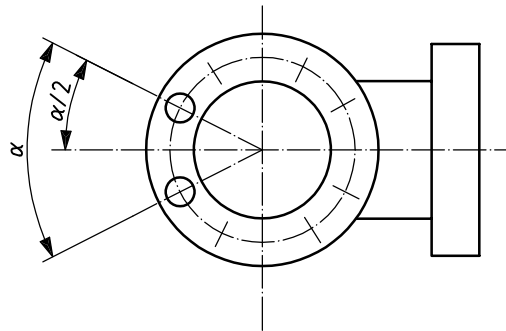

Key

$$\alpha = \frac{360^\circ}{\text{total number of bolt holes}}$$

Figure 4 — Position of bolt holes

Table 1 — Dimensions of pipeline fittings

Dimensions in millimetres

Nominal bore	Edge dimension, <i>e</i>		Length, <i>H</i>		Perpendicularity or parallelism tolerance for the two mating faces for the two flanges specified in	
		tolerance		tolerance	ISO 2861-1	ISO 1609
10	30/40 ^a	± 1,5	60/80 ^a	± 1,5	± 2°	± 1°
16	40		80			
25	50		100			
40	65		130	± 2		
63	88		176			
100	108	216	± 3	Not applicable	± 0°30'	
160	138	276				
200	178	356				
250	208	416				

^a The latter value shall be used only for flanges specified in ISO 1609.

Bibliography

- [1] ISO 3, *Preferred numbers — Series of preferred numbers*
- [2] ISO 3669, *Vacuum technology — Bakable flanges — Dimensions*
- [3] ISO 9803-2, *Vacuum technology — Mounting dimensions of pipeline fittings — Part 2: Knife-edge flange type*

This page is intentionally blank.

This page is intentionally blank.

ICS 23.160

Price based on 5 pages

© ISO 2007 – All rights reserved