**Ophthalmic instruments — Trial case
lenses**

Instruments ophtalmiques — Verres de boîte d'essai



Reference number
ISO 9801:2009(E)

© ISO 2009

PDF disclaimer

This PDF file may contain embedded typefaces. In accordance with Adobe's licensing policy, this file may be printed or viewed but shall not be edited unless the typefaces which are embedded are licensed to and installed on the computer performing the editing. In downloading this file, parties accept therein the responsibility of not infringing Adobe's licensing policy. The ISO Central Secretariat accepts no liability in this area.

Adobe is a trademark of Adobe Systems Incorporated.

Details of the software products used to create this PDF file can be found in the General Info relative to the file; the PDF-creation parameters were optimized for printing. Every care has been taken to ensure that the file is suitable for use by ISO member bodies. In the unlikely event that a problem relating to it is found, please inform the Central Secretariat at the address given below.



COPYRIGHT PROTECTED DOCUMENT

© ISO 2009

All rights reserved. Unless otherwise specified, no part of this publication may be reproduced or utilized in any form or by any means, electronic or mechanical, including photocopying and microfilm, without permission in writing from either ISO at the address below or ISO's member body in the country of the requester.

ISO copyright office
Case postale 56 • CH-1211 Geneva 20
Tel. + 41 22 749 01 11
Fax + 41 22 749 09 47
E-mail copyright@iso.org
Web www.iso.org

Published in Switzerland

Contents

Page

Foreword	iv
1 Scope	1
2 Normative references	1
3 Terms and definitions	1
4 Requirements	2
4.1 General	2
4.2 Optical requirements	2
4.3 Construction	4
4.4 Material and surface quality	5
5 Test methods	5
5.1 General	5
5.2 Checking the optical requirements	5
5.3 Checking material and surface quality	6
5.4 Checking construction	6
6 Functional marking	6
7 Information supplied by the manufacturer	6
7.1 Accompanying documents	6
7.2 Identification of the trial case lens set	7
Annex A (informative) Example of test device for checking accuracy of trial case lens elements	8
Annex B (informative) Example of test device and method for checking material and surface quality	10
Bibliography	11

Foreword

ISO (the International Organization for Standardization) is a worldwide federation of national standards bodies (ISO member bodies). The work of preparing International Standards is normally carried out through ISO technical committees. Each member body interested in a subject for which a technical committee has been established has the right to be represented on that committee. International organizations, governmental and non-governmental, in liaison with ISO, also take part in the work. ISO collaborates closely with the International Electrotechnical Commission (IEC) on all matters of electrotechnical standardization.

International Standards are drafted in accordance with the rules given in the ISO/IEC Directives, Part 2.

The main task of technical committees is to prepare International Standards. Draft International Standards adopted by the technical committees are circulated to the member bodies for voting. Publication as an International Standard requires approval by at least 75 % of the member bodies casting a vote.

Attention is drawn to the possibility that some of the elements of this document may be the subject of patent rights. ISO shall not be held responsible for identifying any or all such patent rights.

ISO 9801 was prepared by Technical Committee ISO/TC 172, *Optics and photonics*, Subcommittee SC 7, *Ophthalmic optics and instruments*.

This second edition cancels and replaces the first edition (ISO 9801:1997), which has undergone a minor revision to update normative references and to include a second standard diameter (see 4.3.2).

Ophthalmic instruments — Trial case lenses

1 Scope

This International Standard specifies requirements for mounted ophthalmic full and/or reduced aperture trial case lenses for the determination of the refractive error of the eye.

This International Standard takes priority over ISO 15004-1, if differences exist.

2 Normative references

The following referenced documents are indispensable for the application of this document. For dated references, only the edition cited applies. For undated references, the latest edition of the referenced document (including any amendments) applies.

ISO 7944, *Optics and optical instruments — Reference wavelengths*

ISO 13666, *Ophthalmic optics — Spectacle lenses — Vocabulary*

ISO 15004-1:2006, *Ophthalmic instruments — Fundamental requirements and test methods — Part 1: General requirements applicable to all ophthalmic instruments*

3 Terms and definitions

For the purposes of this document, the terms and definitions given in ISO 13666 and the following apply.

3.1

trial case lens

lens, in a mount, used to assess the refractive error of the human eye

3.2

full-aperture trial case lens

trial case lens with a protective mount of maximal practical wall thickness of approximately 1 mm, allowing the maximum available free lens aperture

3.3

reduced-aperture trial case lens

trial case lens with the designated free lens aperture significantly less than the mount outer diameter, allowing for considerable reductions in lens thicknesses to be made

3.4

additive power trial case lens set

train of spherical, cylindrical or spherocylindrical combination of trial case lenses, in which the measured back-vertex power at the last surface equals the meridional sums of the labelled values of the train lenses when each element is placed in its specified frame cell

NOTE See ISO 12867.

**3.5
lens power**

⟨spherical lens⟩ back-vertex power, expressed in dioptres (D)

**3.6
lens power**

⟨cylindrical lens⟩ back-vertex power in the principal meridian not equal to zero, expressed in dioptres (D)

NOTE Cylindrical trial case lenses have one principal meridian with zero power.

**3.7
prismatic power**

⟨prismatic lens, prism⟩ prismatic effect, measured as the displacement, in centimetres, of the light ray in a plane perpendicular to its line of incidence on the lens at a distance of 1 m

NOTE 1 Prismatic power is expressed in prism dioptres (Δ).

NOTE 2 The prism base is marked by a line or triangle on the mount (see Clause 6). The position of the prism base is indicated according to ISO 8429.

4 Requirements

4.1 General

The trial case lenses shall conform to the requirements specified in ISO 15004-1. Conformity to the requirements specified in 4.2, 4.3 and 4.4 shall be verified as described in Clause 5.

4.2 Optical requirements

The trial case lenses shall conform to the requirements specified in Tables 1 to 6. Conformity to these requirements shall be verified as described in 5.2.

The dioptric powers indicated in Tables 1 to 4 shall be referenced to the wavelength $\lambda = 546,07$ nm or alternatively $\lambda = 587,56$ nm, in accordance with ISO 7944.

If the requirements are not met for both wavelengths, the reference wavelength used shall be indicated.

The requirements for lenses with nominal zero power (plano) are given in Table 1.

Table 1 — Tolerances on lenses with zero power

Nominal lens power	Tolerance on		
	mean power	residual astigmatism	prismatic power
D	$\frac{S_1 + S_2}{2}$ D	$ S_1 - S_2 $ D	Δ
0	±0,03	0,03	0,06
NOTE S_1 and S_2 refer to the vertex powers in the principal meridians.			

The requirements for lenses with spherical power are given in Table 2.

Table 2 — Tolerances on lenses with spherical power

Nominal spherical power (absolute)	Tolerance on	
	mean power $\frac{S_1 + S_2}{2}$	residual astigmatism $ S_1 - S_2 $
D	D	D
0,12	±0,03	0,03
> 0,12 to 6,00	±0,06	0,03
> 6,00 to 12,00	±0,09	0,03
> 12,00	±0,12	0,03

NOTE S_1 and S_2 refer to the vertex powers in the principal meridians.

The requirements for lenses with cylindrical power are as follows:

- The tolerances in the afocal principal meridian shall be ±0,03 D and 0,12 Δ.
- The tolerances on the cylindrical power principal meridian are given in Table 3.

Table 3 — Tolerances on lenses with cylindrical power

Nominal cylindrical power	Tolerance
D	D
0,12	±0,03
> 0,12 to 1,00	±0,06
> 1,00 to 4,00	±0,09
> 4,00 to 6,00	±0,12
> 6,00	±0,18

The requirements for lenses with prismatic power are given in Table 4.

Table 4 — Tolerances on lenses with prismatic power

Prismatic power		Tolerance	
nominal	Δ	spherical	astigmatic
	tolerance	D	
≤ 6	±0,12	±0,03	0,03
> 6	±0,25	±0,03	0,03

The accuracy of the optical centring of spherical and cylindrical lenses shall be as given in Table 5.

Table 5 — Tolerances on centration

Nominal lens power (absolute) D	Tolerance on Δ at the geometric centre of the mount
$\geq 0,12$ to 2,00	$\pm 0,12$
> 2,00 to 5,00	$\pm 0,25$
> 5,00 to 8,00	$\pm 0,38$
> 8,00 to 12,00	$\pm 0,50$
> 12,00	$\pm 0,75$

The accuracy of the positions of the cylinder axis or the prism base in relation to their corresponding marks (see Clause 6) shall be as given in Table 6.

Table 6 — Tolerances on the marking of the cylinder axis and the prism base

Lenses with cylindrical power	Nominal cylindrical power D	Tolerance
	$\leq 0,25$	$\pm 3^\circ$
	> 0,25 to 0,50	$\pm 2^\circ$
	> 0,50	$\pm 1^\circ$
Lenses with prismatic power	Nominal prismatic power Δ	Tolerance
	$\leq 0,5$	$\pm 7^\circ$
	> 0,5 to 1,0	$\pm 4^\circ$
	> 1,0 to 2,0	$\pm 2^\circ$
	> 2,0 to 10,0	$\pm 1,5^\circ$
> 10,0	$\pm 1^\circ$	

4.3 Construction

4.3.1 General

The following requirements shall apply to all mounts and mounted lenses.

4.3.2 Dimensions

Trial case lenses shall have a circular mount, the rounded edges of which shall have a maximum radius of 1,4 mm.

The outer diameter of the mounted lens shall be either $38_{-0,2}^0$ mm or $28_{-0,2}^0$ mm (for small frames).

NOTE 1 For full- and reduced-aperture mounts in current use, the outer diameters of both mount types are equal.

The maximum thickness of the trial case lens including the mount shall not exceed 2,8 mm.

NOTE 2 Trial case lenses are intended to fit into a trial frame with a lens separation of 3 mm as specified in ISO 12867.

Full-aperture lenses with power in excess of $\pm 5,00$ D may exceed this thickness limit.

Full-aperture prismatic lenses and reduced-aperture prismatic lenses with power in excess of $3,0 \Delta$ may exceed this thickness limit on the side nearer the object.

4.3.3 Free lens aperture

For trial case lenses with a nominal lens power of not more than $12,00$ D, the diameter of the free lens aperture shall be not less than 18 mm.

For trial case lenses with a nominal lens power greater than $12,00$ D, the diameter of the free lens aperture shall be not less than 16 mm.

NOTE An aperture diameter of 16 mm is acceptable for most purposes. A larger diameter is sometimes preferred.

4.3.4 Prismatic lenses

Prismatic lenses shall be mounted so that the surface nearer the eye is parallel to the plane of the mount.

The prismatic power marked on the mount shall be the power for light incident normal to the surface nearer the eye.

NOTE This value corresponds to the result measured with a focimeter.

4.3.5 Mount

The mount shall contain no surfaces, sharp edges or corners which could cause injury to the patient or practitioner under normal conditions of use.

Marks shall be applied to the mount as described in Clause 6.

4.4 Material and surface quality

4.4.1 The lens shall have no blisters, blurs, scratches or other defects, nor any irregularities of the surface which can be recognized with the unaided (naked) eye.

These requirements shall be met over the full free lens aperture.

4.4.2 Materials used in the construction shall be of non-corrosive composition or suitably surface-treated to render them non-corrosive in clinical atmospheric conditions.

5 Test methods

5.1 General

All tests described in this International Standard are type tests.

5.2 Checking the optical requirements

Conformity to the requirements specified in 4.2 shall be tested using a device which does not exceed a measuring error of $0,01$ D or 20 % of the given tolerance for vertex power, whichever is greater, and of $0,5^\circ$ for cylinder axis direction and prism base setting.

ISO 9801:2009(E)

Measurements shall be carried out at the aperture centre of the trial case lens and shall be referred to the reference plane of the test device.

NOTE An example is given in Annex A.

Test results shall be evaluated according to the general rules of statistics.

5.3 Checking material and surface quality

The material and surface quality shall be checked by observation of a "light/dark" boundary through the trial case lens.

NOTE A suitable system is described in Annex B.

5.4 Checking construction

Conformity to the requirements specified in 4.3.2 and 4.3.3 shall be checked with a measuring device, the uncertainty of which does not exceed 0,05 mm.

Conformity to the requirements specified in 4.3.4 and 4.3.5 shall be checked by observation.

6 Functional marking

The nominal vertex or prism power shall be marked on the lens mount.

Cylindrical and prismatic lenses shall be marked with the axis direction or base direction respectively on the mount or on the lens.

If provision has not been made to prevent cylindrical and prismatic lenses turning in the mount, then the marks for the cylinder axis or the prism base shall be made on the lens.

The type of lens shall be indicated by the colour of the mount and/or by the colour of an identification mark or by use of a symbol as given in Table 7.

7 Information supplied by the manufacturer

7.1 Accompanying documents

The trial case lenses shall be accompanied by documents containing instructions for use. In particular this information shall contain:

- a) name and address of the manufacturer;
- b) instructions for disinfection of the trial case lenses;
- c) if the set of trial case lenses is claimed to be an additive power type, then information indicating the method of use;
- d) if appropriate, a statement that the trial case lens set in its original packaging conforms to the transport conditions as specified in 5.3 of ISO 15004-1:2006.

Table 7 — Lens identification marks

Type of lens	Letter or symbol	Colour of mount or identification mark
Spherical and cylindrical lenses	Power value	
Positive	+	Black
Negative ^a	-	Red
Prismatic	Δ	White
Maddox rods	MR	
Stenopaic slits	or SS	
Pinhole discs	⊙ or PH	White or black
Occluder	● or BL	
Frosted lens	FL	
Cross line	⊕ or CL	
Red filter	RF	
Green filter	GF	
Polarization filter	PF	
NOTE 1 The colour, together with certain characteristics of the mount, identifies the type and prefix of the lens, whereas the spherical, cylindrical and prismatic power can be determined from the marked values. The marking of the mount should always be on the side away from the wearer.		
NOTE 2 Additional devices may be marked in a similar way.		
^a In case of crossed cylinders, the axis of the minus cylinder shall be marked in red.		

7.2 Identification of the trial case lens set

The box for the trial case lens set shall be permanently marked with at least the following information:

- a) name and address of manufacturer or supplier;
- b) name and model of trial case lens set;
- c) if appropriate, reference wavelength used (see 4.2);
- d) a reference to this International Standard, i.e. ISO 9801:2009, if the manufacturer or supplier claims compliance with it.

Annex A (informative)

Example of test device for checking accuracy of trial case lens elements

A.1 Determination of spherical and cylindrical power

For testing and determining the tolerances of spherical and cylindrical elements of the trial case lens set, 5.2 requires that the uncertainty of the testing device does not exceed 20 % of the given tolerance of the optical elements. A simplified design of a device for testing these elements is shown in Figure A.1. Commercial lensmeters or focimeters conforming to ISO 8598 do not comply with this requirement.

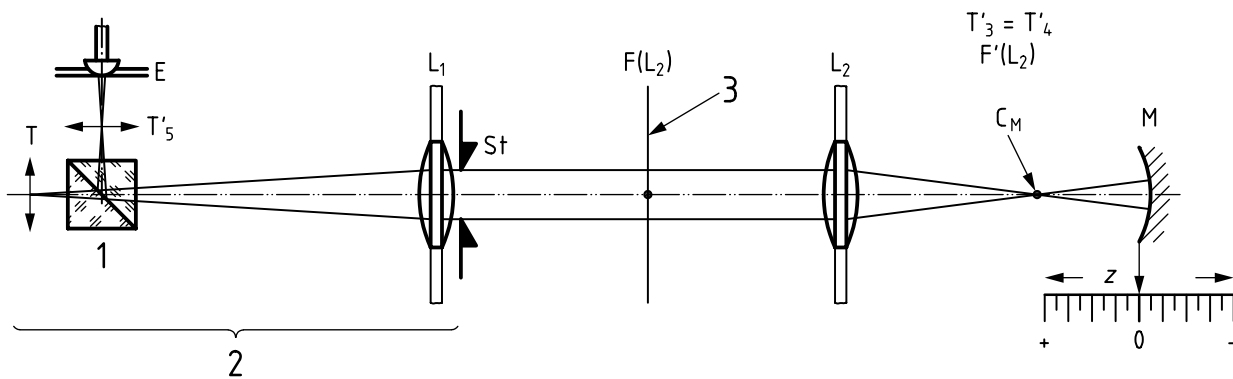

Key

- | | | | |
|----------------|--|---------------------------------|------------------------|
| 1 | beam splitter | E | eyepiece |
| 2 | autocollimating telescope | L ₁ , L ₂ | objective lenses |
| 3 | reference plane for back vertex of trial case lens | St | stop |
| F | focal point | T | target |
| M | mirror | T' | target image |
| C _M | centre of curvature of the mirror | z | movement of the mirror |

Figure A.1 — Set up for a trial case lens test device

The example in Figure A.1 shows the ray tracing when the trial case lens power is zero. The lenses L₁ and L₂ are high quality compound objectives. L₁ and eyepiece E form an autocollimating telescope with a minimum magnification of × 15. The stop St reduces the diameter of the measuring bundle to 7 mm. Lens L₁ of this collimating telescope forms an image T'₁ of target T at infinity. The trial case lens is adjusted to the measuring device so that its reference plane matches the front focal point F(L₂) of the lens L₂ and both optical axes coincide. The front surface of the trial case lens is facing the autocollimating telescope.

As in this example the trial case lens has zero power, it forms image T'₂ = T'₁ at infinity. Lens L₂ forms another image T'₃ at its back focal point F'(L₂). This real image also forms another real image T'₄ coincidentally produced by concave mirror M which is movable along the axis of the test equipment, and whose position is indicated by the precision scale. The coincident images are produced at the centre of curvature C_M of the mirror M and coincidence is achieved by movement of the mirror z. The rays are then reflected back along their original paths, thereby forming image T'₅ on a graticule viewed through eyepiece E.

The vertex power S of the trial case lens is calculated by

$$S = z \left(\frac{1}{f} \right)^2$$

where $(1/f)$ is the power of lens L_2 . As the rays pass through the trial case lens twice (once each way), the measuring accuracy will be twice that of normal focimeters. Refractive errors, therefore, are lowered.

A.2 Prism power and base setting

Prism power and base setting may easily be determined by a laser beam transmitted through the lens. The direction of the beam is to be indicated as described in this International Standard.

Annex B (informative)

Example of test device and method for checking material and surface quality

Place the lens in a suitable system, such as that shown in Figure B.1.

Examine the lens at the “light/dark” boundary without any magnification optics and with the ambient lighting at about 200 lx.

NOTE This observation is subjective and requires some experience.

Dimensions in millimetres

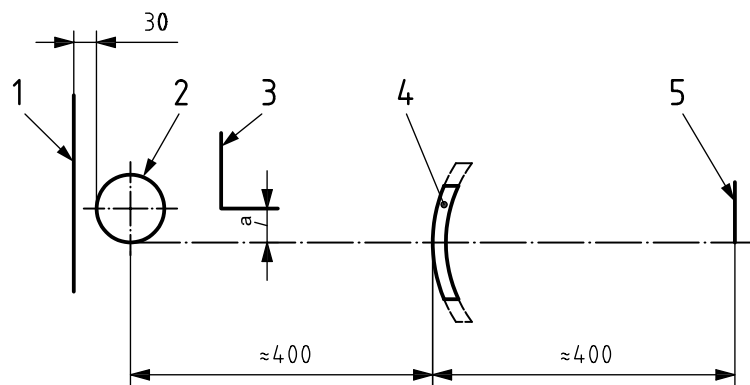

Key

- 1 matt black background (150 mm × 360 mm)
- 2 fluorescent tube, minimum value 15 W (350 lx)
- 3 diaphragm
- 4 movable trial case lens
- 5 plane of the observer's eye
- a Adjustable opaque mask.

Figure B.1 — System for visually inspecting a lens for defects

Bibliography

- [1] ISO 8429, *Optics and optical instruments — Ophthalmology — Graduated dial scale*
- [2] ISO 8598, *Optics and optical instruments — Focimeters*
- [3] ISO 12867, *Ophthalmic instruments — Trial frames*

.....

ICS 11.040.70

Price based on 11 pages